



OPERATOR MANUAL

IMPORTANT INFORMATION, KEEP FOR OPERATOR

888-994-7636, fax 888-864-7636
unifiedbrands.net

THIS MANUAL MUST BE RETAINED FOR FUTURE REFERENCE. READ, UNDERSTAND AND FOLLOW THE INSTRUCTIONS AND WARNINGS CONTAINED IN THIS MANUAL.

FOR YOUR SAFETY Do not store or use gasoline or other flammable vapors and liquids in the vicinity of this or any other appliance.

NOTIFY CARRIER OF DAMAGE AT ONCE It is the responsibility of the consignee to inspect the container upon receipt of same and to determine the possibility of any damage, including concealed damage. Randell suggests that if you are suspicious of damage to make a notation on the delivery receipt. It will be the responsibility of the consignee to file a claim with the carrier. We recommend that you do so at once.

Manufacture Service/Questions 888-994-7636.

This manual provides information for:

DROP-IN SERIES HEATED WELLS MODELS 9560 & 9570



RETAIN THIS MANUAL FOR FUTURE REFERENCE

NOTICE: Due to a continuous program of product improvement, Randell reserves the right to make changes in design and specifications without prior notice.

NOTICE: Please read the entire manual carefully before installation. If certain recommended procedures are not followed, warranty claims will be denied.

MODEL NUMBER _____

SERIAL NUMBER _____

INSTALLATION DATE _____

The serial number is located on the control panel. An example is shown here.



SERIAL NUMBER: XXXXXXXXX
MODEL NUMBER: XXXXXXXXX
DESCRIPTION

EQUIPMENT DESCRIPTION

MODEL	LENGTH	DEPTH	12' x 20' PAN CAPACITY	CUT OUT SIZE		# ELEMENTS	WATTAGE	AMPERAGE @ 60HZ/1PH (AMPS)			SHIP WT (LBS)
				UNIT	CONTROL PANEL			120V	208V	240V	
9560-1	18.5"	26"	1	16.5" x 22.63"	14.25" x 5.75"	1	1100	9.2	5.3	4.6	60
9560-2	31.75"	26"	2	30.125" x 22.63"	14.25" x 5.75"	2	2200	18.3	10.6	9.2	85
9560-3	45.5"	26"	3	43.75" x 22.63"	20" x 5.75"	3	3300	27.5	15.9	13.8	103
9560-4	59.25"	26"	4	57.375" x 22.63"	26" x 5.75"	4	4400	36.7	21.2	18.3	170
9560-5	73"	26"	5	71" x 22.63"	32" x 5.75"	5	5500	45.8	26.4	22.9	230
9560-6	86.75"	26"	6	84.625" x 22.63"	38" x 5.75"	6	6600	55	31.7	27.5	290

MODEL	LENGTH	DEPTH	12' x 20' PAN CAPACITY	CUT OUT SIZE		# ELEMENTS	WATTAGE	AMPERAGE @ 60HZ/1PH (AMPS)		SHIP WT (LBS)
				UNIT	CONTROL PANEL			208V	240V	
9570-2	31.25"	26"	2	28.25" x 22.63"	14" x 5.75"	1	3000	14.4	12.5	110
9570-3	43.75"	26"	3	40.75" x 22.63"	14" x 5.75"	1	3000	14.4	12.5	135
9570-4	56.5"	26"	4	53.375" x 22.63"	14" x 5.75"	2	6000	28.8	25	160
9570-5	69.25"	26"	5	66.25" x 22.63"	14" x 5.75"	2	6000	28.8	25	185
9570-6	82"	26"	6	79.9375" x 22.63"	14" x 5.75"	2	6000	28.8	25	210



Information contained in this document is known to be current and accurate at the time of printing/creation. Reference our product line website for the most updated product information and specifications. © 2023 Electrolux Professional, Inc. All Rights Reserved.

INSTALLATION

RECEIVING SHIPMENT

Upon arrival, examine the exterior of the shipping crate for signs of abuse. It is advisable that the shipping crate be partially removed, in order to examine the cabinet for any possible concealed damages which might have occurred during shipment. If no damages are evident, replace the crate in order to protect the unit during storage and local delivery. If the unit is damaged, the damage should be noted on the delivery slip or bill of lading and signed to that effect. A claim must be filed immediately against the carrier indicating the extent and estimated cost of damage occurred.

LOCATING YOUR NEW UNIT

The following conditions should be considered when selecting a location for your unit:

1. Floor and Counter top load - The area on which the unit will rest must be free of vibration and suitably strong enough to support the combined weights of the unit plus the maximum product load weight.
2. Clearance - There must be a combined total of at least 3" clearance on all sides of the unit.

ELECTRICAL SUPPLY

The wiring should be done by a qualified electrician in accordance with local electrical codes. A properly wired, and grounded outlet is required for proper operation. Consult the data plate attached to the control panel for the correct supply voltage and amperage requirements of the unit.

INSTALLATION CHECKLIST

After the final location of the unit has been determined refer to the following checklist prior to start up:

1. Check all wiring to ensure that there are no kinked, bare, or loose wires.
2. Check that unit fits properly in cabinet and ensure that it is properly leveled.
3. Refer to the front of this manual for serial number location. Please record this information in your manual on page 2 now. It will be necessary when ordering replacement parts or requesting warranty service.
4. Confirm that the unit is holding temperature. Set controls to desired temperature.
5. Check unit for any signs of leaking.

9560 INSTALLATION

1. When installing Model 9560 Drop-in Hot Food unit, a clearance of 1/4" on all sides and 4-1/4" below unit must be maintained from all combustible materials.
2. Control panel must be inserted into cutout before main unit is installed.
3. Secure unit to top and seal with NSF approved silicon.

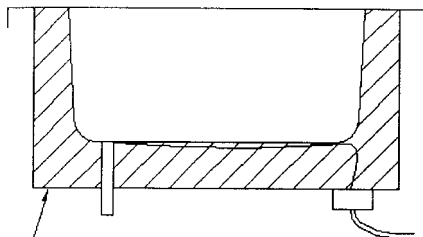

INSULATED OUTER BODY WITH 1/4" FIBER BOARD AROUND OUTER BODY AND FIBERGLASS INSULATION TO FILL ALL SPACING

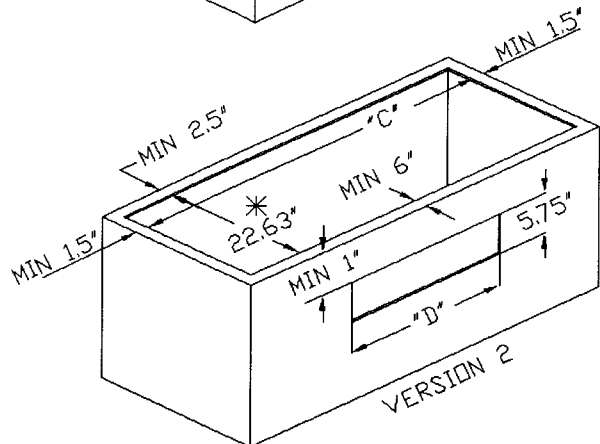
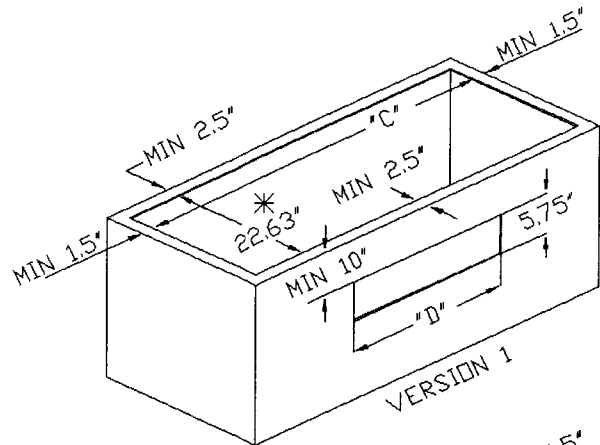
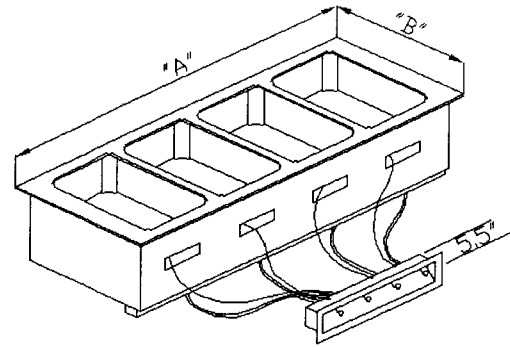

INSTALLATION REQUIREMENTS

MODEL	"A"	"B"	"C"	"D"
9560-1	18.5"	26"	16.5"	14.25"
9560-2	31.75"	26"	30.125"	14.25"
9560-3	45.5"	26"	43.75"	20"
9560-4	59.25"	26"	57.375"	26"
9560-5	73"	26"	71"	32"
9560-6	86.75"	26"	84.625"	38"

* REVISED CUTOUT SIZE FROM 22.5" TO 22.63" 10-18-95

* REVISED CUTOUT SIZE FROM 14" TO 14.25" 6-1-95

9570 INSTALLATION

1. When installing Model 9570 Drop-in Hot Food unit, a clearance of 1.5" on all sides and 6" clearance below the unit must be maintained from all combustible materials.
2. Control panel must be inserted into front cutout before main unit is installed.
3. Secure unit to top and seal with NSF approved silicon.

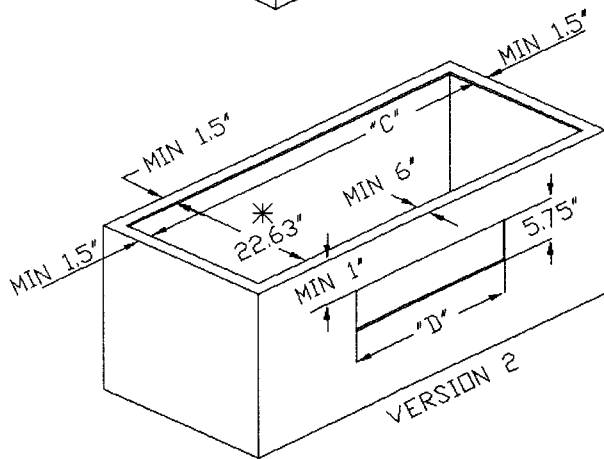
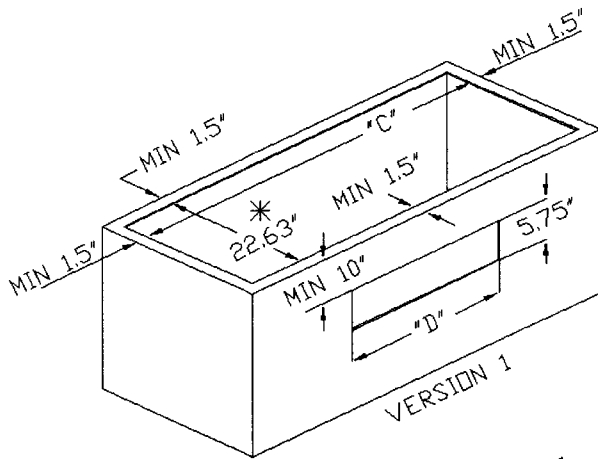
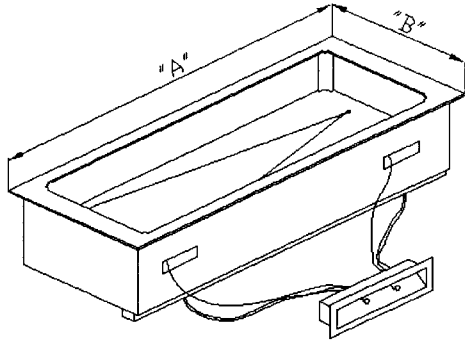

INSTALLATION REQUIREMENTS

MODEL	"A"	"B"	"C"	"D"
9570-2	31.25"	26"	28.25"	14"
9570-3	43.75"	26"	40.75"	14"
9570-4	56.5"	26"	53.375"	14"
9570-5	69.25"	26"	66.25"	14"
9570-6	82"	26"	78.9375"	14"

* REVISED CUTOUT SIZE FROM 22.5" TO 22.63" 10-18-95

OPERATION

All units are designed for 145° to 175° operation or 140° to 170° product temperature. When using the unit dry expect at least a 15° drop in product temperatures compared to using it wet. Electric hot food holding units may be operated utilizing water or dry. Wet operation is usually recommended for higher efficiency.

Plumbing: The units drain must have an outlet to an appropriate drainage area or container.

Note: Drains must be plumbed to all applicable local code requirements.

Caution: Moisture collecting from improper drainage can create a slippery surface on the floor and a hazard to employees. When making electrical connections refer to the amperage data listed on the units data plate. Your local code or the national electrical code handbook to be sure the unit is connected to the proper power source.

PREVENTATIVE MAINTENANCE

Randell strongly suggests a preventive maintenance program which would include the following procedures:

1. Clean your hot food unit with a solution of warm water and a mild detergent. The stainless steel portion of your unit can be polished with any quality polish.
2. Drain water from wells daily and wipe them out. Clean wells thoroughly twice a week to help insure a longer life for your wells.

Note: Do not use chemicals, steel wool or scrapers to clean unit.

Caution: Do not use abrasive cleaning solvents.

Proper maintenance of equipment is necessary to prevent costly repairs. By evaluating each unit on a regular schedule you can often catch and repair minor problems before they completely disable the unit. For more information on preventive maintenance consult your local service company or www.CFESA.com. Most repair companies offer this service at very reasonable rates to allow you the time you need to run your business along with the peace of mind that all your equipment will last throughout its expected life. These services often offer guarantees as well as the flexibility in scheduling of maintenance for your convenience. Randell believes strongly in the products it manufacturers and backs those products with one of the best warranties in the industry. We believe with the proper maintenance and use you will realize a profitable return on your investment and years of satisfied service.

TROUBLESHOOTING

An electric hot food table operates on 120V, 208V or 240V circuits. It draws power through either a fuse or circuit breaker panel; if you suspect an electrical problem, check there first. The heating elements are controlled by electrical temperature controls which sense and regulate temperature.

The following trouble shooting guide list the most common malfunctions in order from most to least likely.

SYMPTOM	POSSIBLE CAUSE	PROCEDURE
Unit will not heat	Thermostat off	Turn on
	Unit unplugged	Plug in unit
	Circuit breaker tripped	Replace breaker
	Unknown problem	Call preferred service agency
Individual well will not heat	Thermostat off	Turn on
	Unknown problem	Call preferred service agency

CONTACT US

If you have questions pertaining to the content in this manual, contact Randell at 888-994-7636.

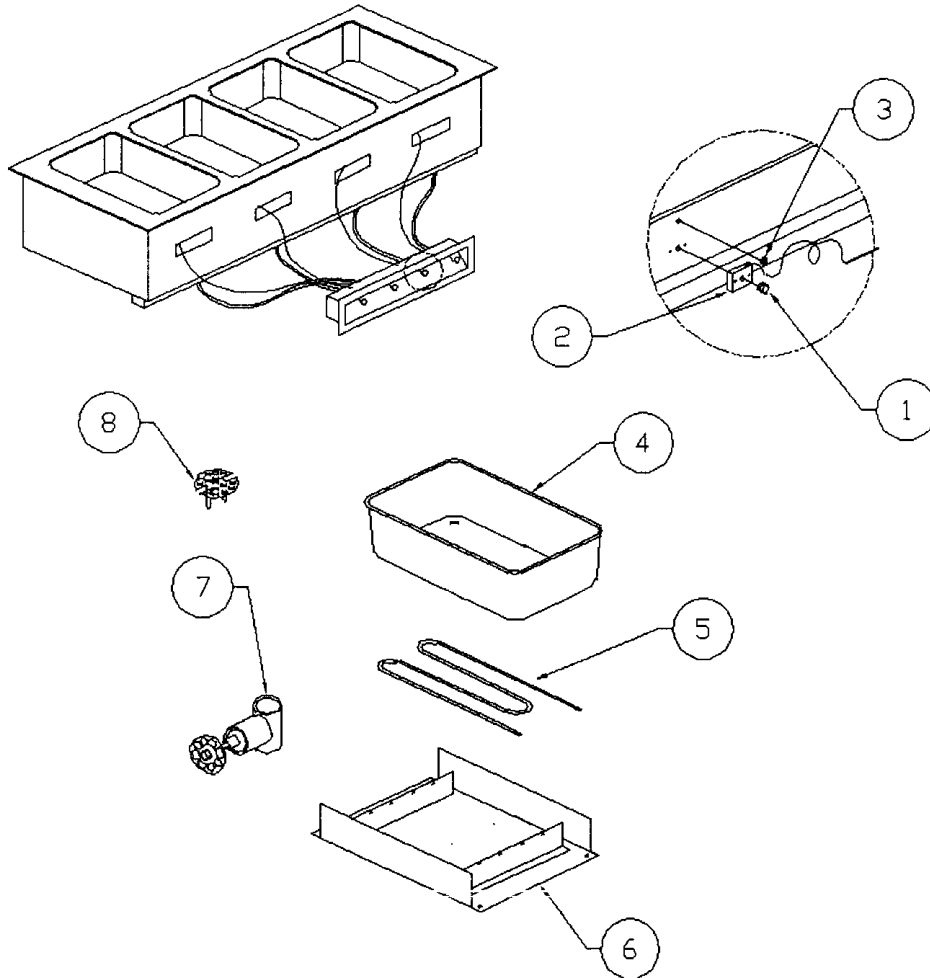

ITEM	PART NUMBER	DESCRIPTION
1	HD KNB003	CONTROL KNOB
2	EL HFT0100	TEMPERATURE CONTROLLER
3	EL LGT500	INDICATOR LIGHT
4A	RP PAN9560WD	PAN, 12X20 SS W/DRAIN
4B	RP PAN9560ND	PAN, 12X20 SS, W/OUT DRAIN
5A	RP ELM9560A	ELEMENT, 120V
5B	RP ELM9560B	ELEMENT, 208V
5C	RP ELM9560C	ELEMENT, 240V
6A	RP PAN014	ELEMENT PAN ASSY W/120V ELEMENT
6B	RP PAN015	ELEMENT PAN ASSY W/204V ELEMENT
6C	RP PAN016	ELEMENT PAN ASSY W/240V ELEMENT
6D	RP PAN017	ELEMENT PAN ASSY W/OUT ELEMMENT
7	PB VLV752	VALVE, 3/4" FPT GATE
8	RP DSN001	DRAIN STRAINER

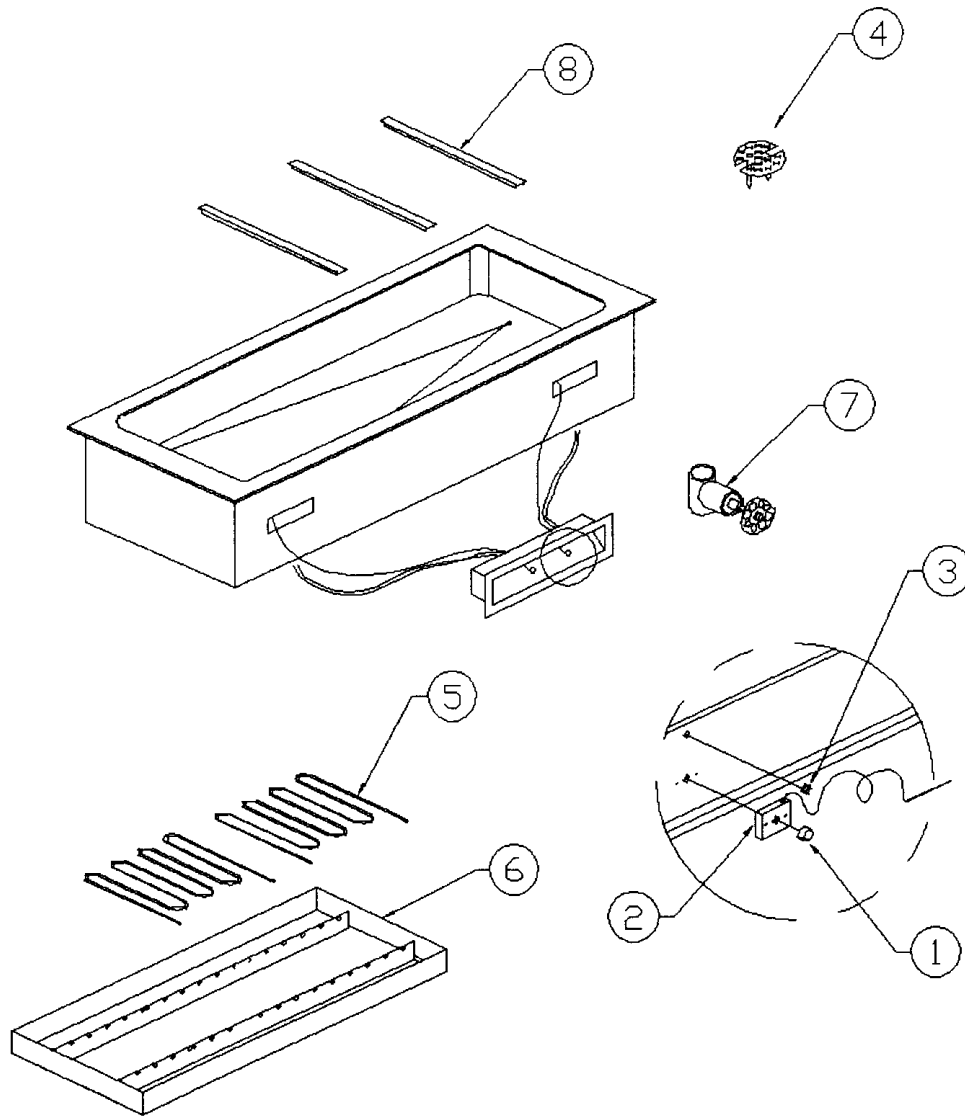

ITEM	PART NUMBER	DESCRIPTION
1	HD KNB003	CONTROL KNOB
2	EL HFT0100	TEMPERATURE CONTROLLER
3	EL LGT500	INDICATOR LIGHT
4	RP DSN001	DRAIN STRAINER
5A	RP ELM3208	ELEMENT, 208V, 3000W
5B	RP ELM3240	ELEMENT, 240V, 3000W
6A	RP PAN008	ELEMENT PAN -- 9570-2
6B	RP PAN009	ELEMENT PAN -- 9570-3
6C	RP PAN011	ELEMENT PAN -- 9570-4
6D	RP PAN012	ELEMENT PAN -- 9570-5
6E	RP PAN013	ELEMENT PAN -- 9570-6
7	PB VLV752	VALVE, 3/4" FPT GATE
8	RP BAR0100	DIVIDER BAR, 20"

