

Operation / Maintenance / Service

Applies to: Indoor or Outdoor, Gas, Direct-Fired, Makeup Air/Heating Systems
Model RDF and Models ADF/ADFH



Model ADF



Model RDF

WARNING:

FIRE OR EXPLOSION HAZARD

Failure to follow safety warnings exactly could result in serious injury, death, or property damage.

Be sure to read and understand the installation, operation, and service instructions in this manual.

Improper installation, adjustment, alteration, service, or maintenance can cause serious injury, death, or property damage.

- Do not store or use gasoline or other flammable vapors and liquids in the vicinity of this or any other appliance.
- **WHAT TO DO IF YOU SMELL GAS**
 - Do not try to light any appliance.
 - Do not touch any electrical switch; do not use any phone in your building.
 - Leave the building immediately.
 - Immediately call your gas supplier from a phone remote from the building. Follow the gas supplier's instructions.
 - If you cannot reach your gas supplier, call the fire department.
- Installation and service must be performed by a qualified installer, service agency, or the gas supplier.

**KEEP THIS BOOKLET FOR
MAINTENANCE AND SERVICE REFERENCE.**

Table of Contents

1.0 General	2	3.4 Air Pressure Switches	9
1.1 Hazard Labels and Notices	2	3.5 Ignition System	10
1.2 Warnings and Requirements .	2	3.6 Gas Train Including Burner, Gas Controls, Manifold Arrangements, and Gas Pressure Switches	11
2.0 Maintenance	3	3.7 Inlet Air Controls	15
2.1 Maintenance Requirements ...	3	3.8 Other Optional Controls.....	16
2.2 Maintenance Schedule	3	3.9 Troubleshooting.....	18
2.3 Maintenance Procedures	4	Additional References.....	19
3.0 Operation and Service	8	INDEX.....	20
3.1 Control Locations	8		
3.2 Electronic Circuit Board with Lights	8		
3.3 Limit Safety Controls.....	9		

1.0 General

The information in this manual applies to Model Series RDF and ADF direct-fired heating/makeup air systems. As with any gas burning equipment, regular maintenance procedures are required to ensure continued safety, reliability and efficiency of the installation.

If service is required, this system should be serviced only by a qualified service person. Service information in this booklet is intended as a guideline for a qualified gas-fired equipment service person.

1.1 Hazard Labels and Notices

This booklet includes operation, maintenance and service information. Before beginning any procedure, carefully review the information, paying particular attention to the warnings.

Definitions of Hazard Intensity Levels used in this Manual

HAZARD INTENSITY LEVELS

1. **DANGER:** Failure to comply will result in severe personal injury or death and/or property damage.
 2. **WARNING:** Failure to comply could result in severe personal injury or death and/or property damage.
 3. **CAUTION:** Failure to comply could result in minor personal injury and/or property damage.
-

There are warning labels on the unit and throughout this manual. For your safety, comply with all warnings during installation, operation, maintenance, and service of this system.

1.2 Warnings and Requirements

WARNING: Improper installation, adjustment, alteration, service, or maintenance can cause property damage, injury, or death. Read the installation, operation, and maintenance instructions thoroughly before installing or servicing this equipment.

WARNING: Gas-fired appliances are not designed for use in hazardous atmospheres containing flammable vapors or combustible dust, or atmospheres containing chlorinated or halogenated hydrocarbons. See Hazard Levels, above.

WARNING: On makeup air heaters which also recirculate room air, outside ventilation air must be provided in accordance with the information shown on the heater rating plate.

Recirculation of room air may be hazardous in the presence of:

- (a) Flammable solids, liquids, and gases;
- (b) Explosive materials (e.g. grain dust, coal dust, gun powder, etc.); or
- (c) Substances which may become toxic when exposed to heat (e.g. refrigerants, aerosols, etc.).

DANGER: The gas burner in this direct gas-fired system is designed and equipped to provide safe, controlled complete combustion. However, if the installation does not permit the burner to receive the proper supply of combustion air, complete combustion may not occur. The result is incomplete combustion which produces carbon monoxide, a poisonous gas that can cause death.

Always comply with the combustion air requirements in the installation codes and operating instructions. The amount of air over the burner must be within the specified range. The burner profile plates are set at the factory to match CFM requirements. Do not adjust the burner profile plates without contacting the factory. **FAILURE TO PROVIDE PROPER COMBUSTION AIR CAN RESULT IN A HEALTH HAZARD WHICH CAN CAUSE PROPERTY DAMAGE, SERIOUS INJURY, AND/OR DEATH.** Direct-fired installations should provide for air changes as required by the applicable installation codes.

2.0 Maintenance

2.1 Maintenance Requirements

This direct-fired makeup air system is designed to require only a minimum amount of maintenance. Some maintenance procedures outlined in this Section require inspection only and some require action. Frequency requirements of each maintenance procedure are listed in the Maintenance Schedule. Depending on the environment and the number of operating hours, more frequent inspection and/or cleaning may be required to certain components.

Although maintenance requirements are minimal, the routine maintenance procedures in this Section are necessary to ensure safe, reliable, and/or efficient operation. The paragraphs which follow discuss the components and systems that require routine inspection/maintenance. At the beginning of each paragraph, there is a code indicating why that maintenance procedure is necessary. The legend for that code is shown on the left.

Maintenance Codes	
S	= Safety (to avoid personal injury and /or property damage)
R	= Continued Reliability
E	= Efficient Operation

WARNING: Disconnect all power to the system before doing any maintenance. Failure to do so may cause electrical shock, personal injury, or death.

2.2 Maintenance Schedule

See Chart, Paragraph 2.3.1	<input type="checkbox"/> Lubricate bearings, Paragraph 2.3.1
Quarterly	<input type="checkbox"/> Check the filters, Paragraph 2.3.2
	<input type="checkbox"/> Check air pressure sensing tubes, Paragraph 2.3.4
Semi-Annually	<input type="checkbox"/> Check blower belts, Paragraph 2.3.1
	<input type="checkbox"/> Verify gas pressures, Paragraph 2.3.3
	<input type="checkbox"/> Clean air pressure sensing tubes, Paragraph 2.3.4
Annually	<input type="checkbox"/> Check indicator lights, Paragraph 2.3.5
	<input type="checkbox"/> Check main burner and pilot assembly, Paragraph 2.3.6

2.0 Maintenance (cont'd)

2.3 Maintenance Procedures

Recommended Bearing Lubrication Schedule in Months

FIGURE 1 - Belt Tension

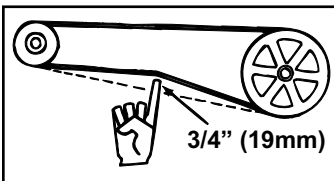

R E 2.3.2 Filters

R 2.3.1 Drive Components

The blower, motor and drive components are located in the blower cabinet. Remove the panels required to access the component(s) being serviced.

Blower Bearings

All blowers are Class I with pillow block bearings. Clean the fitting and add type NLG-2 or -2 standard grade grease. Add grease with a handgun until a slight bead of grease forms at the seal. Be careful not to unseat the seal by over lubricating.

CAUTION: If the blower is unused for more than three months, the bearings should be purged with new grease prior to startup.

RPM Range	Bearing Bore Diameter (Inches)			NOTE: If unusual environmental conditions exist (temperatures below 32°F or above 200°F; moisture; or contaminants) more frequent lubrication is required.
	1/2 to 1	>1 to 1-1/2	>1-1/2 to 1-15/16	
to 1000	6 months	6 months	6 months	
1001-1500	5 months	5 months	5 months	
1501-2000	5 months	4 months	5 months	

Blower Belts

Check belts for proper tension and wear. Adjust belt tension as needed. Replace worn belts.

Proper belt tension is important to the long life of the belt and motor. A loose belt will cause wear and slippage. Too much tension will cause excessive motor and blower bearing wear. If adjustment is required, adjust belt tension by means of the adjusting screw on the motor base until the belt can be depressed 1/2" to 3/4" (FIGURE 1). Tighten the lock nut on the adjusting screw. Be sure the belt is aligned in the pulleys.

If the system includes filters, check the filters quarterly.

To access the filters, remove the filter cabinet door panels. Clean or replace as needed. If filters are removed, be sure the blockoff plates are returned to the filter rack.

Quantity and Size of Filters by Model

Type	Disposable		Permanent		Pleated Disposable	
	1"	2"	1"	2"	1"	2"
Model RDF with Optional Filter Cabinet						
1	-	-	(3)12x35	(4)12x35	-	-
2	-	-	(4)12x35	(4)12x35	-	-
3	-	-	(4)12x24	(4)12x24	-	-
3	-	-	(12)12x35	(10)12x35	-	-
Model ADF/ADFH with Optional Filter Cabinet						
300	(5)12x30-5/8	(5)12x30-5/8	(10)10x16	(10)10x16	(5)12x32	(5)12x32
500	(5)12x20	(5)12x20	(5)12x20	(5)12x20	(5)12x20	(5)12x20
	(5)12x25	(5)12x25	(5)12x25	(5)12x25	(5)12x26	(5)12x26
700, 1200	(5)12x25	(5)12x25	(5)12x25	(5)12x25	(5)12x25	(5)12x25
	(5)12x30-5/8	(5)12x30-5/8	(5)12x32	(5)12x32	(5)12x32	(5)12x32

S 2.3.3 Manifold Gas Pressure

Semiannually, check the gas pressure to the burner and to the pilot. Measure both manifold pressure and pilot supply pressure with the blower in operation. Verify against pressures listed on the rating plate.

FIGURE 2 - Gas Pressure Tap Locations

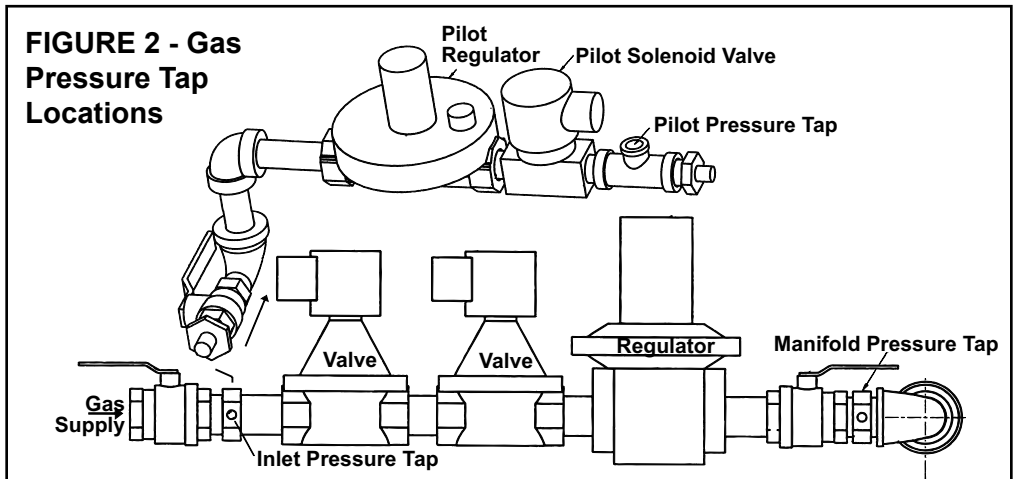

S**2.3.4 Air Pressure**

Profile plate sensing tubes should be checked quarterly and cleaned no less than semi-annually. If the sensing tubes become even partially blocked, false pressure readings may be relayed.

To clean, remove the screened end caps and clean the screens and the tubes. Replace the clean end caps. Check the pressure differential across the profile plate using a slope gauge. To attach the slope gauge, open the control compartment door panel. Just below the junction box, locate the tubing connections. Remove the cap at each connection and attach the slope gauge using two field-supplied 1/4" x 1/8" female NPT barbed tubing connections. For instructions on measuring air pressure, see Paragraph 3.4. Air pressure differential should be between -.25" and -.75" w.c.

R**2.3.5 Circuit Indicator Board (check lights)**

The circuit indicator board is located in the control compartment electrical box (See **FIGURE 9**, page 8). Check operation of all indicator lights by switching lights that are not lit with one that is currently lit. Replace any burned out indicator bulbs (P/N **125189**).

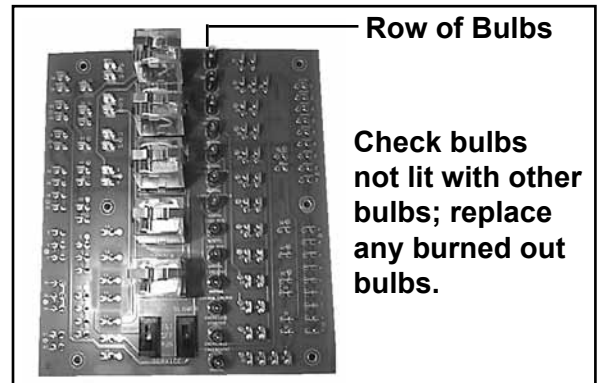
FIGURE 3 - Circuit Indicator Board, P/N 151263**S****2.3.6 Main Burner and Pilot Assembly**

For the most part, the burner and pilot are self cleaning. However, if the application is extremely dirty or dusty, cleaning of the burner and pilot may be necessary. Inspect the burner annually. Follow these instructions. If it is necessary to replace any parts, use only factory-authorized replacements.

- 1) Turn off the gas and power supply to the system.
- 2) Remove the door panels in the burner/control cabinet. Locate the pilot.

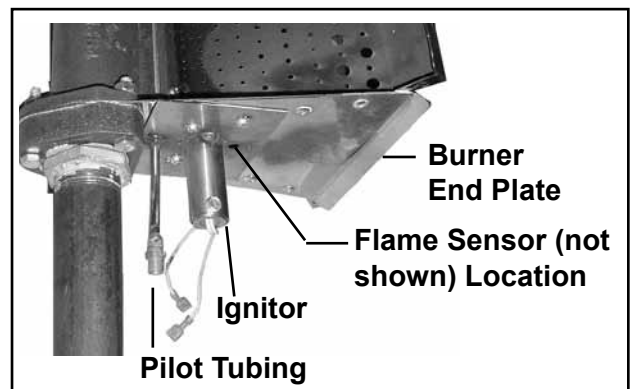
FIGURE 4 - Burner End Plate showing Hot Surface Ignitor

NOTE: Model RDF units manufactured prior to 3/96 have a spark ignition system. Clean ultraviolet sensor and spark plug. Replace as needed.

CAUTION: Wear eye protection while pressure cleaning and drilling.

WARNING: Do not enlarge burner ports or performance may be drastically affected.

FIGURE 5 - Direct Fired Burner

WARNING: Burner profile plates are factory set to match CFM requirements. Do not adjust profile plates without contacting your Sales Representative for technical assistance.

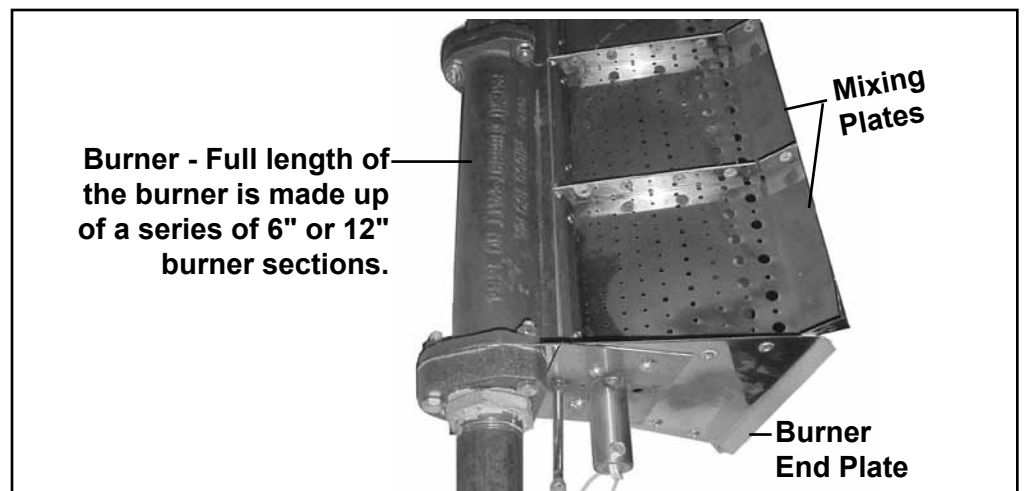

2.0 Maintenance (cont'd)

2.3 Maintenance Procedures (cont'd)

CAUTION: Wear eye protection while pressure cleaning and drilling.

WARNING: Do not enlarge burner ports or performance may be drastically affected.



2.3.7 Optional Evaporative Cooling Module

2.3.6 Main Burner and Pilot Assembly (cont'd)

- 3) Disconnect the two ignition wires (male and female quick connections) and disconnect the flame sensor lead at the burner. Remove the setscrew located in the ignitor tube (setscrew holds the brass bushing in place). Carefully remove the brass bushing and the ignitor.
Check the hot surface ignitor for cracks or unusual deterioration. Check the flame rod for integrity. Replace the flame rod (P/N 134706) and/or the hot surface ignitor (P/N 121865) if not in good condition.
- 4) Clean the burner and pilot by back-flushing, using high pressure air (40-80 lbs). Continue until dust particles are completely expelled from both the upstream and downstream sides of the burner.
If air pressure does not unplug burner orifices or pilot tube, drill burner orifices with a Size #50 drill and/or pilot tube with a Size #55 drill.
Inspect the upstream and downstream sides of the mixing plates. Remove any accumulation of scale or foreign material with a wire brush. If any mixing plate fasteners are loose or missing, tighten or replace. Always use zinc plated or stainless fasteners.
If any cracks are present, replace that mixing plate. Because of the effect of flame temperature on the metal, fasteners may be difficult to remove. Be careful not to damage the gaskets that go between the mixing plates and the burner body. The gaskets are designed to overlap approximately 1/16" for airtight seal.
- 5) Follow Steps in reverse order to re-install the pilot assembly. Close all panels and check for proper operation.

Media - Over time, excessive amounts of mineral deposits will begin to buildup on the media. Annually, scale and dirt should be washed off the entering surface of the media. Remove the pad retainers and screen. (See Steps 1-3 and 6-8 of Media Replacement Instructions.) Clean the media using a garden hose, mild soap, and a soft bristled brush. When the media becomes too clogged with mineral deposits and dirt that it cannot be cleaned, the pads should be replaced. The average pad life is approximately three cooling seasons.

See charts and **NOTE** below for replacement media information. Follow the instructions and remove and replace pads as shown in **FIGURE 6**.

Evaporative Cooling Media - Model ADF or ADFH with Option AS3, AS4, AS5, or AS8

ADF / ADFH	Media Pad Size & Qty		Replacement P/N's (each) - 12" media *	
	(inches)	Qty	Cellulose	Glass Fiber
300	24 x 12	2	106021	106029
	24 x 7-7/8	1	106022	106030
500	24 x 12	3	106021	106029
	24 x 9-5/8	1	106025	106033
700/	48 x 12	4	107194	107201
1200	48 x 8-5/8	1	107195	107202

* **NOTE:** 6" media is no longer available as a replacement part. Use size to obtain media from a local supplier.

Evaporative Cooling Media - Model RDF with attached Model REC Evaporative Cooling Module

REC	Media Pad		Replacement P/N's (each) *	
	Size	Qty	12" Cellulose	12" Glass Fiber
40	24x12	2	106021	106029
	24x2-3/8	1	106022	106030
50	24x12	2	106021	106029
	24x7-7/8	1	106023	106031
60	24x12	3	106021	106029
	24x1-3/8	1	106024	106032
70	24x12	3	106021	106029
	24x9-5/8	1	106025	106033
80	24x12	4	106021	106029
	24x2-7/8	1	106026	106034
90	24x12	4	106021	106029
	24x8-5/8	1	106027	106035
180	48x12	4	107194	107201
	48x8-5/8	1	107195	107202
360	48x12	8	107194	107201
	48x8-5/8	2	107195	107202

1. Remove the three sheetmetal screws that hold the top pad retainer in place. Release the top pad retainer from the cooling module.
2. Remove the three sheetmetal screws that hold the bottom pad retainer in place. Release bottom pad retainer from the cooling module.
3. Disengage the screen retainers from the sides of the media.
4. Disengage inlet screen from media pads and remove.
5. Slide all media pads horizontally away from the cooling module until clear of bottom reservoir pan. Dispose of properly.

Instructions for Replacing Evaporative Cooling Media

FIGURE 6 - Removal and Replacement of Evaporative Cooling Module Media

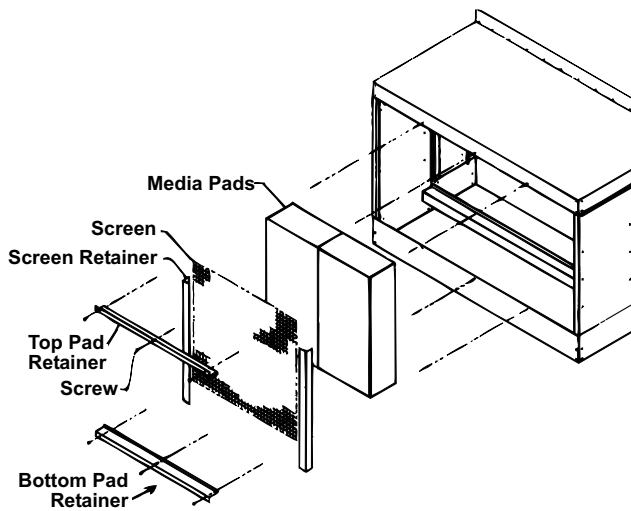
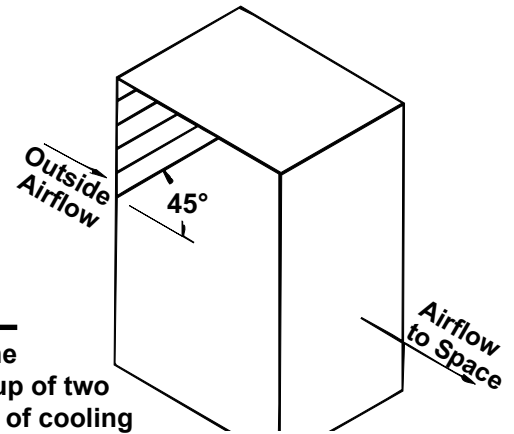

FIGURE 7 - Media must be installed with 45° angle sloping downward toward the incoming outside air.



IMPORTANT: The media is made up of two different sheets of cooling material. Each sheet has its own unique angle. When replacing the cooling media, **BE CERTAIN** that the 45° angle slopes downward toward the incoming outside air (as illustrated above). If the media is not installed properly, water blowoff from the media pads will occur.

6. Replace media by sliding media pads over both support rails until back stop is encountered. Media **must** be placed as shown in **FIGURE 7**.
7. Center screen on the incoming air side of the media.
8. Replace the two side screen retainers by fitting them between the side of the media pad and the side of the cooling module. The retainers should fit snugly, pinching the screen against the media pads.
9. Replace the bottom pad retainer by securing the retainer between the pad and the reservoir pan. Fasten with the three sheetmetal screws removed in Step 2.
10. Replace the top pad retainer by securing the retainer between the pad and top of the cooling module. Fasten with the three sheetmetal screws removed in Step 1.

Other Evaporative Cooling Module Maintenance

REFERENCE:
Evaporative Cooling Module Troubleshooting Guide, Paragraph 3.9, page 19, Chart 2.

Water Feed Line and PVC Distribution Piping - Annually, the water supply line and PVC water distribution pipe should be flushed of debris and contaminants.

1. Remove the media pads following the media replacement instructions.
2. Remove the water feed line from the downstream side of the ball valve and unscrew the water bleed line barbed hose fitting.
3. Force a fresh water supply through the water inlet hose and thoroughly flush the distribution pipe.
4. Reassemble being careful to install media with air flow direction as shown in **FIGURE 7**.

Water Pump and Inlet Basket Screen (applies to system with float and pump control) -- Annually, the pump and inlet basket screen should be removed, disassembled, and cleaned.

WARNING: Do not expose pump motor or any part of the electrical box to water. Evaporative cooling pump is NOT submersible.

1. Disconnect the power supply to the unit.

FIGURE 8 - Remove Junction Box, Pump and Float Switch as an Assembly

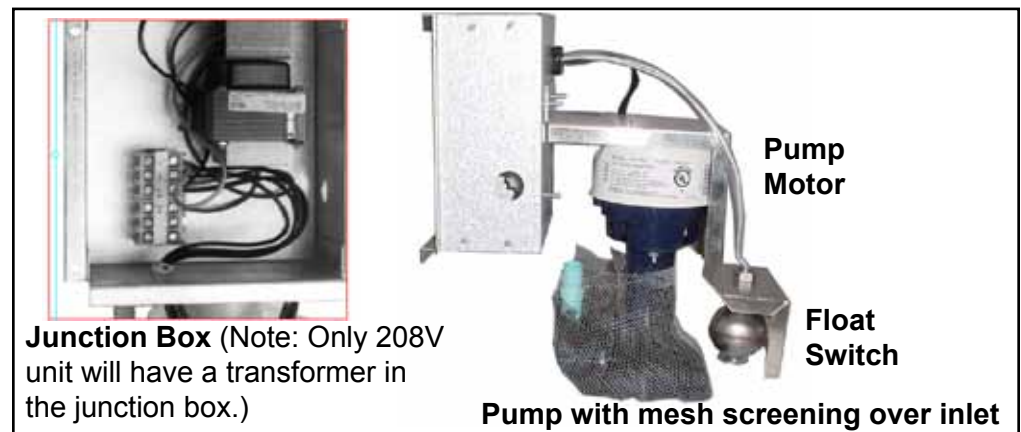

2.0 Maintenance (cont'd)

2.3 Maintenance Procedures (cont'd)

3.0 Operation and Service

2.3.7 Optional Evaporative Cooling Module (cont'd)

2. Remove the service panel and the junction box door. Disconnect the two-line voltage power supply wires from the terminal block inside the junction box.
3. Disconnect the water feed line hose from the upstream side of the ball valve.
4. Unscrew the four sheetmetal screws holding the junction box to the cooling module. Remove the junction box-pump-float switch assembly (See **FIGURE 8**).
5. Dislodge the inlet basket screen from the pump and clean any buildup of debris and dirt. Carefully remove the base cover plate from the bottom of the pump. Using a mild soap solution, wash all deposits from the inside of the pump and remove all debris from the impeller.
6. Reassemble the pump. Replace the parts in exact reverse order, being careful that everything is returned to its proper position.

3.1 Control Locations

To service this system, it is necessary to understand the normal operation of the controls and the function of the diagnostic circuit board. Refer to the electrical box drawing in **FIGURE 9** and to the individual illustrations to identify and locate each of the controls. The wiring diagrams for this unit are located in the main electrical box.

WARNING: Service work on this system should only be done by a qualified gas service person. The service information and the troubleshooting guides are intended as an aid to a qualified service person.

FIGURE 9 - Control Identification and Typical Locations

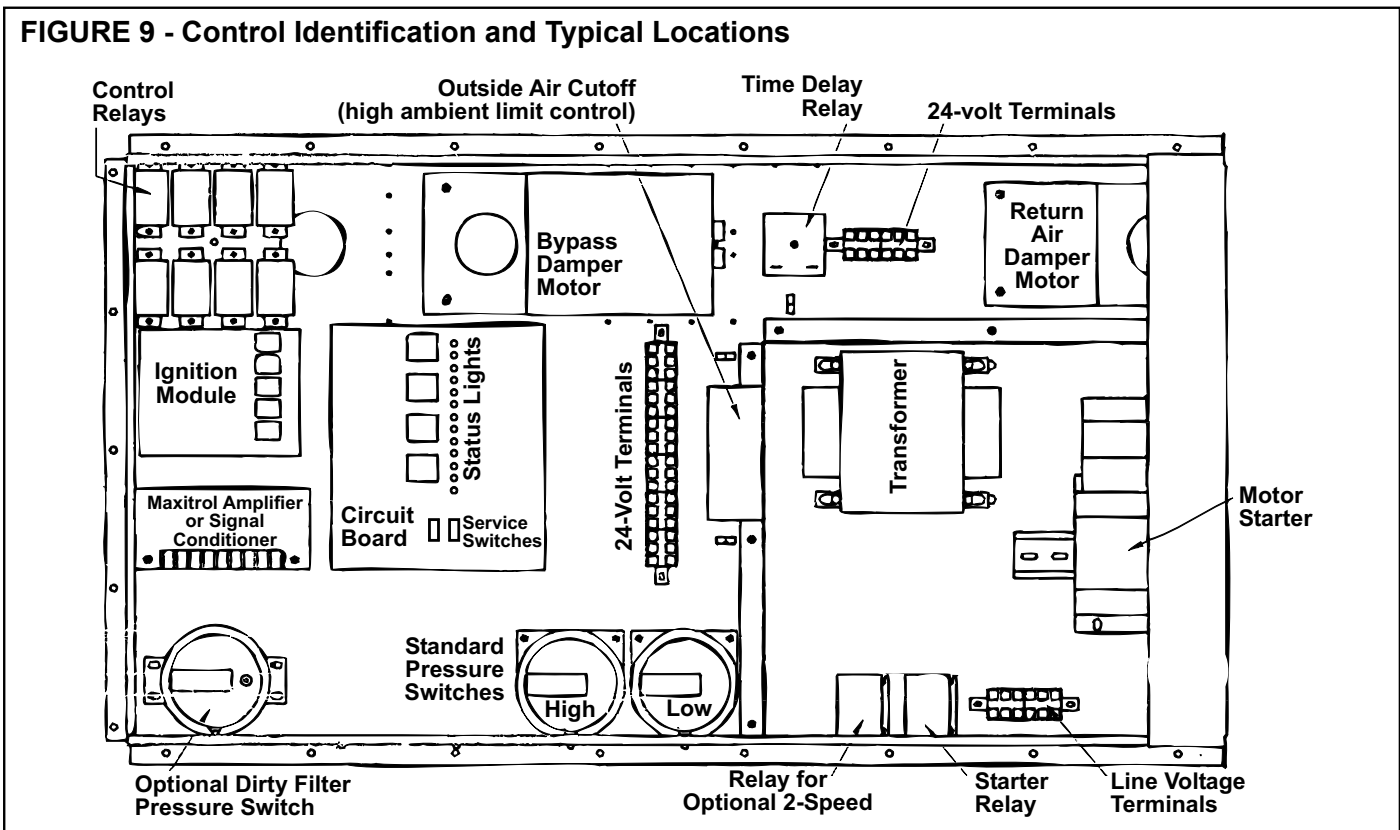

3.2 Electronic Circuit Board with Lights

Location: Control Compartment Electrical Box (See **FIGURE 9**)

Function: The diagnostic lights on the circuit board are designed to assist in troubleshooting. When the system is operating properly, the lights on the circuit board are lit. If the system fails to operate properly, all lights on the circuit board up to the one that represents the component or system that has failed will be lit. For more detailed information, refer to the Troubleshooting Guide in Paragraph 3.9..

Service: Replacing burned out bulbs is the only service required. If a bulb is not lit, check the bulb by switching it with a bulb that is lit.

FIGURE 10 - Diagnostic Circuit Board, P/N 151263

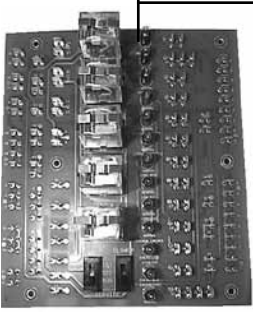

Column of 13 indicator bulbs; always replace burned out bulbs, P/N 125189.

- Control Switch Energized
- Firestat Normal
- Freezestat Normal
- Starter Energized
- Blower ON - High Air Pressure Normal
- Blower ON - Low Air Pressure Normal
- Control Circuit Power
- Manual and Auto Limits Normal
- Outside Air Cutoff Normal
- Low Gas Pressure Normal
- High Gas Pressure Normal
- Pilot Valve Energized
- Gas Safety Valve Energized

3.3 Limit Safety Controls

FIGURE 11 - Automatic Reset Limit Controls



Model	P/N	Setting
RDF	86979	135°F
ADF	122856	130°F
ADFH	57953	170°F

Each unit has an automatic temperature activated limit control, a manual reset temperature activated limit control, and an electrical activated energy cutoff device.

• Automatic Reset Limit Control

Function: If the temperature of the discharge air reaches the setpoint, the limit will open the circuit to the burner system and close all burner and pilot valves. The limit control will be activated if total airflow is reduced or if gas pressure surges at the burner causing excessive discharge air temperature. The system will restart when the discharge air temperature decreases below the setpoint.

Service: Failure of this limit requires replacement of the control.

• Manual Reset Limit Control

Function: The manual reset limit has a higher setting than the automatic limit and requires manual resetting to restart the system. If for any reason the automatic limit should fail to protect against overheating, the manual limit will shutdown the system. Should the manual reset limit activate, check the entire system to determine the cause. Make any necessary changes or adjustments before restarting the burner system. Restart of the unit can be done only after the limit has been cooled and the reset button depressed.

CAUTION: If the manual reset limit activates, find and correct the cause before restarting the system.

Service: Failure of this limit requires replacement of the control.

FIGURE 12 - Manual Reset Limit Controls



<p>Model RDF - Setting 150°F, P/N 82610</p> 	<p>Reset Button</p>	<p>Model ADF - Setting 135°F, P/N 122858; Model ADFH - Setting 175°F, P/N 122990</p> 
--	----------------------------	---

FIGURE 13 - ECO Limit Control



Setting 305°F
P/N 82414

• Emergency Cut Off Limit Control

Function: The emergency cut off is a fusible link high temperature limit which provides onetime redundant protection against overheating. If the temperature sensitive limit controls malfunction, the electrically activated emergency cutoff will shutdown the system.

Service: If this limit activates, the manual limit control has failed and must be replaced. The cause for activating the emergency cut off limit control must be found and corrected before re-starting the system.

3.4 Air Pressure Switches

Location: Control Compartment Electrical Box (See **FIGURE 9**.)

• Low Airflow Switch

Function: The low airflow switch is a velocity pressure switch that monitors airflow across the burner. Until the airflow attains adequate volume for combustion, the switch remains open. When the switch recognizes adequate air volume, it closes, permitting both the pilot and burner to operate. Low pressure switch is normally open; it closes on pressure rise at .25" w.c. Do not alter or adjust setting.

3.0 Operation and Service (cont'd)

3.4 Air Pressure Switches (cont'd)



• High Airflow Switch

Function: The high airflow switch is a velocity pressure switch that monitors airflow across the burner. If the high airflow switch senses air velocity above the prescribed limit, it will shutdown gas flow to the burner. High pressure switch is normally closed; it opens when pressure rises above .75" w.c. Do not alter or adjust setting.

Low and High Airflow Sensing Pressure Check: (requires slope gauge, several feet of 1/4" OD tubing and two 1/4" OD barbed tees.)

Attach a slope gauge (0 to 1.0" scale) to the tubing connections in the control compartment. The two connections are located below the electrical control box. Remove the caps on the 1/8" NPT test connections and attach the slope gauge. (The recommended method for attaching the slope gauge is to use field-supplied 1/8" female NPT x 1/4" O.D. barbed hose connections.)

- A) If the system includes an optional discharge damper, before measuring burner differential air pressure, check to be sure that the damper is fully open.
- B) With the blower operating, the pressure differential on the slope gauge should read between -.25" and -.75" w.c. If the slope gauge reading is within those limits, no adjustments are necessary. If pressure reading is not within limits, consult the factory.
- C) When air pressure is within the proper range, turn the disconnect switch OFF. Disconnect the manometer and the slope gauge. Replace the caps removed to connect the slope gauge.

Pressure Switches and Bypass Damper Airflow (Applies to Model RDF system with Air Control Option AR19, AR20, AR22, AR23, AR32, AR33, AR34, AR36, or AR37)

Adjustment of the bypass damper is controlled by the same low and high pressure switches described above. With a bypass damper, the volume of outside air supplied to the building is controlled by a manually set potentiometer (Option AR19 and AR22) or automatically by a pressure null switch (Option AR20 or AR23), a photohelic pressure switch (Option AR36 or AR37), or a field-supplied computer signal (Option AR33 or AR34). With Options AR19, AR20, AR33, and AR36 the supply air is varied by adjusting the position of a damper at the blower discharge. With Options AR22, AR23, AR34, and AR37, a return air damper is adjusted to vary the volume of return air. The unit is arranged so that a fixed amount (20%) of the rated volume flows over the burner at a constant velocity. The remainder (80%) of the rated air volume flows either through a balancing bypass damper or a combination of bypass and return air dampers. As the supply air volume is varied by the return air or discharge damper, the balancing damper is adjusted to maintain the required air velocity over the burner. See Paragraph 3.7 for information about inlet air control options.

Service: If the pressure check determines that an airflow switch is not functioning properly, the switch cannot be serviced and must be replaced with an identical replacement. Low air pressure switch is P/N 203932; high air pressure switch is P/N 203933..

3.5 Ignition System

Location: Ignition Controller Module in the Control Compartment Electrical Box (See FIGURES 9 and 15.); Ignitor and Flame Sensor on the Burner (See FIGURE 16.)

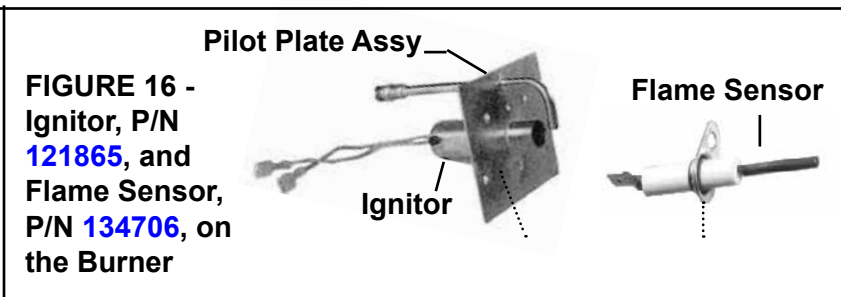
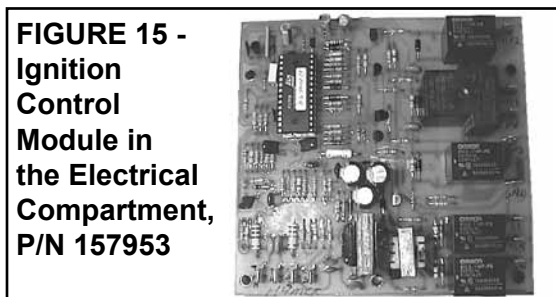

Hot Surface Ignition System with Prepurge Time Delay and Flame Sensor with Lockout

Function: The ignition system including the controller, the hot surface ignitor, and the flame sensor function to ignite and prove the pilot flame. When there is a call for heat, the modular ignition controller is energized. When the controller reads 1.4 amps going to the hot surface ignitor, it opens the pilot valve for a 15-second trial for ignition. After the pilot flame rod senses pilot flame, the main gas valve is energized.

3.6 Gas Train Including Burner, Gas Controls, Manifold Arrangements, and Gas Pressure Switches

FIGURE 17 - Single-Stage Gas Valve and Discharge Air Controller in Makeup Air Gas Control System, Option AG1



FIGURE 18 - Two-Stage Gas Valve and Discharge Ductstat in Makeup Air Gas Control System, Option AG3



If the pilot flame rod does not sense a pilot flame, the controller shuts down the pilot valve for a 10-second interpurge and then opens it again for a second ignition trial. If pilot flame is not proven on the second trial, the ignition controller locks out and must be manually reset by an interruption of the main circuit (disconnect switch).

If the burner ordered is over three feet long (Model RDF with burner Option BL7, BL8, BL9, BL10, BL11, or BL13), a second flame rod is located at the end of the burner. After the main gas valve(s) is energized, a 15-second trial to prove the second flame is initiated. Failure to recognize and prove flame travel to the opposite end of the burner will result in a pre-purge and re-try for ignition.

Service: The modular ignition controller does an internal self-check each time that it is energized and will lockout if not found to be functioning properly. If the ignition controller locks out and there is no other cause, the controller module must be replaced.

Direct-Fired Burner

Function: The design of the direct-fired burner and the controlled velocity of air at the burner ensure complete combustion through the full range of burner sizes and gas inputs as determined by the gas control system. The velocity of air is controlled by the profile plates and monitored by a standard low and high air pressure switch.

Service: Refer to Paragraph 2.3.6 for instructions on burner maintenance.

WARNING: Burner profile plates are factory set to match CFM requirements. Do not adjust profile plates without contacting your Sales Representative for technical assistance.

Makeup Air (100% Outside Air) Gas Control Systems

• Single-Stage Gas Valve for Makeup Air (Option AG1) (750MBH maximum)

The standard 24-volt, single state gas valve has an integral automatic electric on-off valve, a pressure regulator, a safety pilot valve, and a manual shutoff. The valve operates in response to a call for heat from a unit-mounted air controller that monitors discharge air temperature. The controller has a built-in setpoint selector from 0° - 100°F. Due to different CFM settings and outside temperatures, the average downstream outlet temperature may not match the control setting exactly. After the installation is complete, adjust the setpoint to achieve the desired average outlet air temperature. See the valve manufacturer's literature provided in the owner's envelope for specifications, wiring, and operating information.

• Two-Stage Gas Valve for Makeup Air (Option AG3) (750 MBH maximum)

The single-stage valve is replaced by a two-stage valve having low fire and high fire operation. The two-stage valve is controlled by a unit-mounted ductstat that monitors discharge air temperature. The ductstat has a built-in setpoint selector from 60°-110°F. Available for use with natural gas only.

Due to different CFM settings and outside air temperatures, the average downstream outlet temperature may not match the ductstat setting exactly. After the installation is complete, adjust the setpoint of the ductstat to achieve the desired average outlet air temperature. See the valve manufacturer's literature provided in the owner's envelope for specifications, wiring, and operating information.

• Electronic Modulation Gas Control for Makeup Air (100% Outside Air), Options AG30, AG31, AG32, AG33, AG35, AG36

Refer to the wiring diagrams in the main electrical box to determine which controls are on the system being serviced. **NOTE:** All field-supplied control wiring for Maxitrol controls must *not* be run inside conduit with line voltage wiring. To avoid any potential electrical interference, all field-supplied wiring for Maxitrol controls should be shielded wiring and must be grounded at the unit only.

Function: These gas control systems provide heated makeup air at a temperature controlled by a discharge air sensor. Makeup air gas controls apply only to systems with 100% outside air. Each system is equipped with electronic modulation controls that modulate burner flame from 1/25th of full fire input to full fire.

3.0 Operation and Service (cont'd)

FIGURE 20 - Modulating Gas Valve - Options AG30, AG31, AG32, AG33, AG35, AG36



3.6 Gas Train Including Burner, Gas Controls, Manifold Arrangements, and Gas Pressure Switches (cont'd)

The electronic modulating-type gas controls act in response to discharge and/or room air temperature sensors to change the gas flow rate to the burner, thus lengthening or shortening the flame. The BTU output is varied (modulated) to maintain the required discharge air temperature.

These modulating gas control options are electronic because in all cases the gas valve acts to adjust the flow of the gas to the main burner in response to DC volts emanating from an amplifier. When the DC voltage is between 0 and 5 volts, the main valve seat is closed. Low fire flow is accomplished through a mechanical bypass. The low fire flow rate is set at the factory and should not need adjustment. However, if adjustment is necessary, refer to the Maxitrol literature that is included in the heater owner's envelope.

All of the electronic makeup air modulating gas control burner systems include low fire start. On an initial call for heat, the main burner ignites at its lowest input. During mild weather, the burner may then cycle off. Such full shutdown can be dictated by the outdoor ambient cutoff control. As the outside air temperature climbs above the setpoint of the outdoor ambient control, the burner control circuit is de-energized. When moderately cold outside air temperatures exist, the burner will modulate between low flame and high flame. Low fire start and the outdoor ambient control prevent the makeup air system from heating already warm air and providing "too much" heat to the building. For troubleshooting guides and further explanation of Maxitrol Series 14 and 44 electronic modulation gas control systems, refer to the Maxitrol literature in the owner's envelope.

The Option AG30, AG31, AG32, and AG35 electronic modulation systems are comprised of Maxitrol Series 14 controls for makeup air. Options AG30 and AG31 systems electronically maintain a constant discharge air temperature in the range of 55-90°F. Option AG31 includes an overriding thermostat. Option AG32 system will maintain a constant discharge air temperature in the range of 80-130°F. Option AG35 maintains a discharge temperature range of 120-160°F.

FIGURE 21 - Maxitrol Series 14 Components used in Makeup Air Gas Control Options AG30, AG31, AG32, AG35

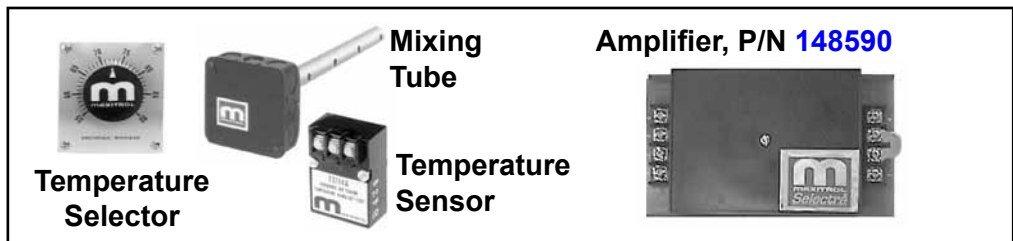

Option AG33 electronic modulation system is comprised of Maxitrol Series 44 controls for makeup air. The low limit (20-60°F) and the high limit (60-140°F) for control of discharge air temperature are set at the amplifier located in the control compartment. The space temperature is set at the remote selectrstat (55-90°F range) located in the space. When the temperature is below the space temperature setpoint, the control system operates the burner to automatically adjust the discharge air temperature within the maximum and minimum limits set on the amplifier.

FIGURE 22 - Maxitrol Series 44 Components used in Makeup Air Gas Control Option AG33

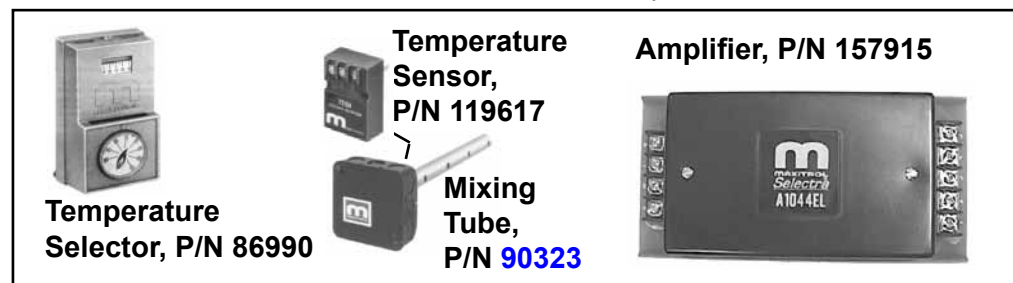

Option AG36 is a special application gas train that is designed for controlling the environment of a paint booth operation. The system includes a Maxitrol A1494 amplifier, discharge air temperature sensor, dual remote discharge air temperature selector (drying selector 80-140°F and a spray selector 60-90°F), and two switches to control the operation of the modulating gas valve.

FIGURE 23 - Components of the Gas Control System used in Option AG36 designed specifically for paint booths - controls are mounted on a remote console



FIGURE 24 - Maxitrol Signal Conditioner for Computer Control

• **Electronic Modulation Makeup Air Gas Control Option AG37**



Function: Control Option AG37 does not have a duct sensor or amplifier. Instead, a Maxitrol signal conditioner is activated by a customer-supplied input signal (either 4-20 milliamps or 0-10 volt) to control the modulation of the gas valve.

FIGURE 25 - Modulating Gas Valve - Options AG47 and AG48



Makeup Air with Recirculation Air Gas Control Systems (RDF only)

• **Electronic Modulation Makeup Air with Recirculation Gas Control Options AG47, AG48, and AG51**

Refer to the wiring diagrams in the main electrical box to determine which controls are on the system being serviced. **NOTE:** All field-supplied control wiring for Maxitrol controls must **not** be run inside conduit with line voltage wiring. To avoid any potential electrical interference, all field-supplied wiring for Maxitrol controls should be shielded wiring and must be grounded at the unit only.

Function: These **makeup air with recirculation** gas control systems provide a mix of outside and recirculated air heated to a temperature controlled by a discharge air sensor. Each system is equipped with electronic modulation controls that modulate burner flame from 1/25th of full fire input to full fire and adjust the outside air damper in response to outside and return air sensors.

Both the flow of the gas to the main burner and the outside (bypass) air damper position are adjusted in response to DC volts emanating from an amplifier. When the DC voltage is between 0 and 5 volts, the main valve seat is closed. Low fire gas flow is accomplished through a mechanical bypass. Minimum outside air is 25%. Carbon dioxide (CO₂) in the discharge air of the unit is maintained to a level in compliance with ANSI Z83.18 requirements.

For troubleshooting guides and further explanation of Maxitrol Series 14 and 44 electronic modulation gas control recirculation systems, refer to the Maxitrol literature in the owner's envelope.

Option AG47 electronic modulation system is comprised of Maxitrol Series 14 controls for makeup air with recirculation. The system electronically operates the burner and/or the outside air damper to maintain a constant discharge air temperature in the range of 40-95°F.

FIGURE 26 - Maxitrol Series 14 Components used in Recirculation Air Gas Control Option AG47



Option AG48 electronic modulation system is comprised of Maxitrol Series 44 controls for makeup air with recirculation. The low limit (20-60°F) and the high limit (60-140°F) for control of discharge air temperature are set at the amplifier. The space temperature is set at the remote selectostat (55-90°F range) located in the space. When the temperature is below the space temperature setpoint, the control system operates the burner and/or the outside air damper to automatically adjust the discharge air temperature within the maximum and minimum limits set on the amplifier.

3.0 Operation and Service (cont'd)

3.6 Gas Train Including Burner, Gas Controls, Manifold Arrangements, and Gas Pressure Switches (cont'd)

FIGURE 27 -
Maxitrol Series
44 Components
used in
Recirculation
Air Gas Control
Option **AG48**



Amplifier, P/N 204450



**Selector,
P/N 204451**



**Discharge
Air Sensor,
P/N 204453**



**Return Air Sensor,
P/N 204452
Outside Air Sensor,
P/N 204452**

Option AG51 electronic modulation system is comprised of the same Maxitrol Series 44 controls as Option AG48 plus a remote sensor/selector.

FIGURE 28 - Option AG51 includes Maxitrol Series 44 Components used in AG48 plus a Remote Sensor



**Remote
Sensor/
Selector,
P/N 204456**

Service - ALL Gas Controls: Check all electrical connections. A qualified service person should refer to the control manufacturer's literature for assistance in identifying problems and determining the correct solution. None of the controls have field replaceable parts. All components must be replaced with identical replacement parts.

Manifold Arrangements

Description: The manifold is the gas train from the gas supply connection to the burner. The manifold selection ordered determines the manifold arrangement including all of the gas train components except the main control valve. Manifold arrangements are available for varying BTUH ranges and gas controls and meet ANSI, CSA, FM or GAP (former IRI) requirements.

All manifold arrangements include two 5psi rated manual shutoffs.

These systems are designed to operate on a natural gas supply differential pressure range of a minimum of 4.3-5.0" w.c. plus the manifold pressure drop. Maximum supply pressure depends on manifold selection; see below. If the gas supply pressure is above the maximum allowed, it is necessary to install a field-supplied step-down gas regulator in the supply line. Order and install the appropriate Gas Regulator Kit, Option CZ1 (1") or CZ2 (1-1/2"). Follow the instructions provided with the kit. Measure the gas pressure between the step-down regulator and the unit.

(Refer to the wiring diagram or rating plate to identify the manifold on the system being serviced.)

Manifold Option BM75, BM76 - 1/2 psi
Manifold Option BM78, BM79 - 2 psi
Manifold Option BM80, BM81 - 5 psi

Maximum Supply Pressure by Manifold

The table right lists the minimum supply pressure required for manifold and gas control combinations. Refer to the wiring diagram to be sure which combination of options applies to the system being serviced.

Minimum Supply Gas Pressure ("w.c.) for Full Fire														
Manifold Option	BM75				BM76		BM78		BM79		BM80		BM81	
with Gas Control Option	AG1		AG3		AG 30, 31, 32, 33, 35, 36, 37, 47, 48, or 51		AG 30, 31, 32, 33, 35, 36, 37, 47, 48, or 51							
Manifold Size	1"		1"		1"		1"		1-1/4"		1-1/4"		2"	
MBH	Nat	Pro	Nat	Pro	Nat	Pro	Nat	Pro	Nat	Pro	Nat	Pro	Nat	Pro
250	4.0	1.4	4.0	N/A	4.1	1.6	4.4	1.6	4.6	1.6	4.5	1.6	5.1	1.8
500	5.3	1.9	5.0	N/A	5.8	2.3	6.0	2.3	5.2	1.9	5.0	1.7	5.3	1.9
750	7.5	2.7	6.8	N/A	8.5	3.3	8.4	3.3	6.1	2.3	5.7	2.0	5.5	1.9
1000					12.4	4.7	11.7	4.6	7.4	2.8	6.7	2.4	5.8	2.1
1250									9.1	3.5	8.0	2.9	6.2	2.2
1500									11.2	4.3	9.6	3.5	6.6	2.4
1750									13.6	5.3	11.5	4.2	7.2	2.6
2000									16.5	6.3	13.7	5.0	7.8	2.8
2500									23.3	8.9	18.9	7.0	9.4	3.4
3000													11.3	4.1

If the gas train includes either or both high and low gas pressure switches, the switches monitor gas pressure downstream from the safety valves.

If the gas pressure in a system equipped with a high gas pressure switch (standard with manifold Options BM 78, 79, 80 and 81; Option BP2 with other manifolds) exceeds the setpoint, the switch will open the electrical circuit to the burner, stopping all gas flow. The high gas pressure switch is a manually reset device.

A low gas pressure switch (Option BP3) will shutoff the gas flow if the gas pressure drops below the setpoint of the low pressure switch. The low gas pressure switch will automatically reset when the gas pressure rises above the setpoint.

FIGURE 29 - Gas Pressure Switches

<p>Low Gas Pressure Switch, P/N 204375 (automatic)</p>		<p>High Gas Pressure Switch, P/N 204297 (manual reset)</p>	
<p>(NOTE: Both high and low gas pressure switches incorporate a vent limiting device and do not require venting to the outdoors when used in an indoor installation.)</p>			

3.7 Inlet Air Controls

WARNING: Burner profile plates are factory set to match CFM requirements. Do not adjust profile plates without contacting your Sales Representative for technical assistance.

Description: The system is equipped with one of the 11 types of inlet air control arrangements listed below. All systems provide a constant flow of outside air across the burner at the required air volume (CFM). Refer to the wiring diagrams in the main electrical box to determine which controls are on the system being serviced.

- **Option AR1** - a constant supply of **100% makeup air**
- **Option AR19** - **100% outside makeup air** with variable supply air volume (CFM). The discharge damper controlling the variable air supply is controlled by a manually set remote potentiometer and can be varied from 100% to 20-25% of total rated airflow (CFM). In response to changes in the discharge damper setting, the bypass damper balances the volume of air so that the required fixed amount of air volume flows over the burner.
- **Option AR20** - **100% outside makeup air** with variable supply air volume (CFM). The discharge damper controlling the variable air supply is automatically controlled by a building pressure sensor and can be varied from 100% to 20-25% of total rated airflow (CFM). In response to changes in the discharge damper setting, the bypass damper balances the volume of air so that the required fixed amount of air volume flows over the burner.
- **Option AR22** - a combination of **outside makeup air and bypass return air** including modulating return air and bypass air dampers. The volume of outside air is regulated by a remotely located, manually set potentiometer.
- **Option AR23** - a combination of **outside makeup air and bypass return air** including modulating return air and bypass air dampers. The volume of outside air is regulated automatically by a remotely located building pressure sensor.
- **Option AR33** - **100% outside makeup air** with variable supply air volume (CFM). The discharge damper controlling the variable air supply is automatically controlled by a 0-10 VCD or 4-20 milliamp signal. In response to changes in the discharge damper setting, the bypass damper balances the volume of air so that the required fixed amount of air volume flows over the burner.
- **Option AR34** - a combination of **outside makeup air and bypass return air** including modulating return air and bypass air dampers. The volume of outside air is regulated by a 0-10 VCD or 4-20 milliamp signal.
- **Option AR36** - **100% outside makeup air** with variable supply air volume (CFM). The discharge damper controlling the variable air supply is automatically controlled by a remotely located photohelic pressure sensor. In response to changes in the discharge damper setting, the bypass damper balances the volume of air so that the required fixed amount of air volume flows over the burner.
- **Option AR37** - a combination of **outside makeup air and bypass return air** including modulating return air and bypass air dampers. The volume of outside air is regulated by a remotely located photohelic pressure sensor.

Airflow Dampers

Function: Dampers operate in response to controls to provide the rated flow of makeup air to the building. Minimum outside air is 20-25%.

Service: Clean all dampers of dust or dirt.

Damper Motor



FIGURE 30 - Damper Motor

Function: The damper motor automatically actuates the return air, bypass, and/or discharge dampers in response to an electrical control device. The damper motor is direct-coupled to the dampers so there is no damper linkage to adjust.

Service: There is no service required on these motors other than external cleaning. If the motors need replaced, replace with an identical damper motor.

3.0 Operation and Service (cont'd)

3.7 Inlet Air Controls (cont'd)

Pressure Null Switch (automatic building pressure sensor)



FIGURE 32 - Pressure Null Switch, P/N 88052

Photohelic Pressure Switch (automatic building pressure sensor)



FIGURE 33 - Photohelic Pressure Sensor, P/N 159893

3.8 Other Optional Controls

FIGURE 34 - Outside Air Cutoff Control, P/N 126170



Potentiometer

FIGURE 31 - Potentiometer, P/N 16110



Function: The potentiometer is a manually set switch that operates either the discharge damper (Option AR19) or the return air damper (Option AR22) providing a mixture of return and outside air. It is a remotely located switch that requires manual adjustment.

Service: If the potentiometer does not function properly, replace it with an identical switch.

Description/Function: The pressure null switch is a diaphragm operated differential pressure switch used in makeup air applications to automatically control building pressure. It maintains a selected positive or negative pressure setpoint by changing the amount of outside air being introduced to the building through modulating outside air damper. As more pressure is required in the building, the pressure null switch activates the damper motor driving the outside air damper towards the full open position (causing the bypass return air damper to go toward the closed position). Conversely, as less pressure is required, the switch drives the outside air damper in the opposite direction.

Service: Clean the tubing and the screened ends of the pressure tap vents. Be sure that the switch is installed with the diaphragm in a vertical plane and that the pressure taps are sheltered from the wind. For further service, follow the manufacturer's instructions included with the switch.

Description/Function: The photohelic pressure switch is a phototransistor relay operated positive pressure switch used in makeup air applications to automatically control building pressure. It maintains a selected positive pressure setpoint by changing the amount of outside air being introduced to the building through a modulating outside air damper. As more pressure is required in the building, the switch activates the damper motor driving the outside air damper towards the full open position (causing the bypass return air damper to go toward the closed position). Conversely, as less pressure is required, the switch drives the outside air damper in the opposite direction.

Service: Clean the tubing and the screened ends of the pressure tap vents.

If the interior of the switch is protected from dust, dirt, corrosive gases and fluids, years of trouble-free service may be expected. Zero adjustment should be checked and reset occasionally to maintain accuracy; follow the manufacturer's instructions included with the switch.

There are no field-repairable parts in this switch. If the switch should require repair, contact either the system or the switch manufacturer concerning switch replacement or repair.

Outside Air Cutoff Control (Option BN2)

Location: The control is in the electrical box (FIGURE 9.); the sensor is in the air inlet.

Function: After sensing pilot flame, the burner ignites at its lowest input rate. The "amount of heat" required to reach the desired discharge temperature also depends on the temperature of the incoming outside air. The outside air control is factory set at 60°F (adjustable 25-250°F). The burner reacts differently depending on the entering air temperature and the setting on the outside air control. The burner --

- may not ignite (pilot valve will not open);
If the actual temperature of the outside air is above the setpoint on the outside air control, the burner will not ignite.
- may modulate to satisfy discharge setting;
- would shutdown completely only on Option BN2 control, once burner has been fired; or
Modulating operation will depend on the temperature rise between the outside air and the discharge air setting.
- may remain on continuous low fire.
If the outside air control is set too high, the burner will continuously burn on low fire as long as the control switch is set to "winter".

When the outside air control is set properly for the climate, the system blower will continue to provide the required makeup air (ventilation) at the ambient outdoor temperature (burner not operating) even when the control switch is set to "winter".

Service: If the control does not function properly, replace it with an identical switch.

**FIGURE 35 -
Door Switch,
P/N 124253**



Door Switch (Option BX1)

Location: The control is installed on an overhead door opening to control the operation of the heater to coincide with the opening and closing of the door.

Function: The function of the switch is to energize and interlock the heating unit when an outside overhead door reaches approximately 80% of full open travel. The switch will de-energize the furnace when the overhead door closes approximately 20%. The complete switch includes a limit switch electrically wired to the heater and a roller yoke for mechanical activation by a field-supplied trigger on the overhead door.

**FIGURE 36 - Dirty Filter
Pressure Switch,
P/N 105507**



Dirty Filter Switch (component of Remote Console Option RC14)

Location: Switch is located in the main electrical box (See **FIGURE 9**); sensor tubes run to either side of the filter rack; indicator light is on the remote console.

Function: The dirty filter switch is a pressure switch that activates an indicator light on the remote console when the filters need cleaned or replaced (See Paragraph 2.3.2). This switch is only on systems with an optional console that includes a dirty filter light. The pressure switch is set during installation so that the light will be activated at approximately 50% filter blockage. Contacts should close at .17 to 5.0" w.c. \pm .05" w.c.

Service: Clean the sensor tubes. If the dirty filter indicator system still does not function properly, check the setting of the switch. With clean filters in place, blower doors closed, and blower in operation, decrease the pressure setting by adjusting the setscrew on the switch clockwise until the filter light is energized or screw is bottomed out. At that point, adjust the setscrew three full turns counterclockwise or until the screw is top ended.

If it is determined that the switch needs replacing, use an identical switch. When a new switch is installed, it must be manually set; follow the instructions above.

**FIGURE 37 -
Firestat,
P/N 42782**



Firestat (Option BD2 or BD4)

Location: Firestat in Option BD2 is factory-mounted in the unit. Firestat in Option BD4 is field-mounted on the return air ductwork with the sensor extending into the duct. This control requires manual reset so it should be mounted in an accessible location.

Function: The firestat will shut down the system if the temperature at the sensor reaches 200°F. The switch must be manually reset.

Service: Clean the external surface. Check the wiring and connections.

**FIGURE 38 -
Photoelectric Smoke
Detector (cover
removed), P/N 159553,
used with sampling
tube, P/N 159714**



Photoelectric Smoke Detector (Option SA1)

Location: Field-mounted in the discharge ductwork.

Function: The detector will shut down the system if smoke is detected in the discharge ductwork.

Service: Clean the external surface. Check the wiring and connections.

FIGURE 39 - P/N 126170



Low Temperature Limit (Freezestat), Option BE2

Location: The control is in the blower section electrical box; the sensing bulb is field-mounted in the discharge duct.

Function: The freezestat will shut down the system if the discharge temperature falls below the setpoint. The switch is automatic and will startup the heater when the temperature reaches the setpoint.

Service: Clean the external surface. Check the wiring and connections. Freezestat Controller is P/N 126170.

3.0 Operation and Service (cont'd)

3.9 Troubleshooting

Chart 1 - System Troubleshooting (Check the diagnostic lights.)

Symptom or Problem	Cause and Remedy
1. Disconnect switch is closed, but "control power" light is not lit.	<ol style="list-style-type: none"> 1. Fuses are missing or blown in disconnect switch - replace fuses. 2. Transformer not wired according to diagram - check wiring. 3. Secondary 8A fuse (on transformer) is missing or blown - replace fuse. 4. Indicator light is burned out - replace bulb (P/N 125189).
2. Disconnect switch is closed, but "firestat normal" light is not lit.	<ol style="list-style-type: none"> 1. See causes and remedies for Problem 1 above. 2. Optional control relay or door switch contacts are open - to test, jump terminals 3 to 4 or 1 to 2 3. Firestat option not ordered - verify order/wiring diagram. 4. Firestat manual reset tripped - reset firestat control.
3. Disconnect closed, blower switch in test position, "firestat" light is lit, but "freezestat" light is not lit	<ol style="list-style-type: none"> 1. Freezestat option not ordered - verify order/wiring diagram. 2. Freezestat relay contacts are open - checking setting on control. 3. Indicator bulb is burned out - replace bulb (P/N 125189).
4. Disconnect closed, blower switch in test position, "firestat" and "freezestat" lights are lit, but "starter energized" light is not lit and the blower motor is not operating.	<ol style="list-style-type: none"> 1. End switch on damper motor not closed. - check end switch wiring. 2. Faulty damper relay - replace relay. 3. Damper motor miswired - rewire damper motor per wiring diagram.
5. Disconnect closed, blower switch in test position, "firestat", "freezestat" and "starter energized" lights are lit, but the blower motor is not operating.	<ol style="list-style-type: none"> 1. Blower motor not wired correctly - check wiring diagram on motor. 2. Faulty motor starter - replace (check coil first). 3. Faulty blower motor relay - replace relay.
6. Disconnect closed; blower switch in test position; "firestat", "freezestat" and "starter energized" lights are lit and the blower motor is operating; but the "low air light" is not lit.	<ol style="list-style-type: none"> 1. Low air switch open - verify pressure drop at burner. 2. Indicator light is burned out - replace bulb (P/N 125189). 3. Faulty low air switch - replace pressure switch (P/N 203932).
7. Disconnect closed; blower switch in test position; "firestat", "freezestat", "starter energized" and "low air" lights are lit and the blower motor is operating; but the "high air light" is not lit.	<ol style="list-style-type: none"> 1. High air switch open - verify pressure drop at burner. 2. Indicator light is burned out - replace bulb (P/N 125189). 3. High air switch option not ordered - verify order/wiring diagram. 4. Faulty high air switch - replace pressure switch (P/N 203933).
8. Disconnect closed; blower switch in test position; "firestat", "freezestat", "starter energized", "low air" and "high air" are lit; but the "limit control normal" light is not lit.	<ol style="list-style-type: none"> 1. Indicator light is burned out - replace bulb (P/N 125189). 2. Tripped manual reset limit control(s) - reset manual control. 3. Faulty manual limit control (s) - replace limit control.
9. Disconnect closed; blower switch in test position; "firestat", "freezestat", "starter energized", "low air", "high air" and "limit control normal" lights are lit; but the "ambient (outside air) cutoff normal" light is not lit.	<ol style="list-style-type: none"> 1. Indicator light is burned out - replace bulb (P/N 125189). 2. High ambient control option not ordered - verify order/wiring diagram. 3. High ambient control contacts open - check setting on control.
10. Disconnect closed; blower switch in test position; "firestat", "freezestat", "starter energized", "low air", "high air", "limit control normal" and "ambient (outside air) cutoff normal" lights are lit; but the "low gas pressure normal" light is not lit.	<ol style="list-style-type: none"> 1. Indicator light is burned out - replace bulb (P/N 125189). 2. Low gas pressure switch option not ordered - verify order/wiring diagram. 3. Low gas pressure switch contacts open - check setting on control. 4. Low gas pressure switch contacts open - check gas pressure. 5. Faulty gas pressure switch - replace gas pressure switch.
11. Disconnect closed; blower switch in test position; "firestat", "freezestat", "starter energized", "low air", "high air", "limit controls normal", "ambient (outside air) cutoff normal" and "low gas pressure normal" lights are lit; but the "high gas pressure normal" light is not lit.	<ol style="list-style-type: none"> 1. Indicator light is burned out - replace bulb (P/N 125189). 2. High gas pressure switch option not ordered - verify order/wiring diagram. 3. High gas pressure switch contacts open - check setting on control. 4. High gas pressure switch contacts open - check gas pressure. 5. Manual reset on switch tripped - reset pressure switch manual reset. 6. Faulty gas pressure switch - replace gas pressure switch.
12. Disconnect closed; blower and burner switches in run position; control switch is in "winter" position; "control power", "high gas normal"; "low gas normal"; "firestat normal"; "system switch energized"; "starter energized" and "freezestat normal" lights are lit; but igniter is not becoming energized or beginning to glow.	<ol style="list-style-type: none"> 1. Lack of power at L1 on ignition module - ECO blown, find cause then replace ECO. 2. Faulty burner enable relay - replace relay. 3. Low stage relay contacts are not closed - check air controller or thermostat setting. 4. Faulty low stage relay - replace relay. 5. Faulty hot surface ignitor - check continuity at the ignition module and circuit board. If reading is greater than 5-6 ohms, replace ignitor. 6. Faulty ignition module - replace entire module.
13. Disconnect closed; blower and burner switches in run position; control switch is in "winter" position; "control power", high gas normal; "low gas normal"; "firestat normal"; "system switch energized"; "starter energized" and "freezestat normal" lights are lit; ignitor glowing but "pilot valve normal" light (thus the pilot valve) is not energized.	<ol style="list-style-type: none"> 1. Ignitor not reaching 1.4A threshold - check voltage and current to ignitor. 2. Faulty hot surface ignitor - check continuity, replace ignitor. 3. Faulty ignition module - replace entire module.
14. Disconnect closed; blower and burner switches in run position; control switch is in "winter" position; "control power", high gas normal; "low gas normal"; "firestat normal"; "system switch energized"; "starter energized" and "freezestat normal" lights are lit; ignitor has reached 1.4A and has opened the pilot valve bringing on the "pilot valve normal" light; but the pilot flame is not present. (After two trials the unit will go into safety lockout requiring cycling of the main disconnect switch.)	<ol style="list-style-type: none"> 1. Air in pilot gas line - bleed pilot line. 2. Inadequate pilot gas pressure - verify pilot gas pressure (3.5" w.c.) 3. Faulty pilot valve - replace pilot solenoid valve. 4. Faulty ignition module - replace entire module.

15. Disconnect closed; blower and burner switches in run position; control switch is in "winter" position; all status lights are lit except "main valve normal" light. The pilot flame is present and stable, but the (low stage portion or) main gas valve will not open, or rapid cycling of the main valve is occurring.	1. Microamp signal on flame rod is inadequate - check position and condition of flame rod and signal (minimum 0.5 microamps required.)
	2. Grounding for unit or flame rod inadequate - check ground path.
	3. Faulty main gas valve - replace main gas valve.
	4. Faulty ignition module - replace ignition module.
	5. Inadequate main gas pressure - verify main burner pressure.
16. Disconnect closed; blower and burner switches in run position; control switch is in "winter" position; all status lights are lit; the pilot flame and low fire on the main burner are present and stable, but the unit will not progress to a high fire condition.	1. Faulty main gas valve - replace main gas valve.
	2. Inadequate timing on high fire time delay relay - adjust setting.
	3. Faulty high fire time delay relay - replace time delay relay.
	4. High stage relay contacts are not closed - check control setting.
	5. Inadequate main gas pressure - verify main burner gas pressure.
	6. Faulty high stage relay - replace relay.
	7. Faulty ignition module - replace entire module.

REFERENCE: For service and troubleshooting information on the electrical controls, refer to the manufacturer's literature covering that component. Component literature is included in the literature envelope.

Chart 2 - Troubleshooting Optional Evaporative Cooling Module

WARNING: Disconnect the power before servicing the cooling module. Failure to do so can cause electrical shock, personal injury or death.

Problem	Probable Cause	Remedy
Float & Pump Control System - Pump does not run. Control is calling for cooling and reservoir is full.	1. Electrical connections	1. Verify all electrical connections. See Wiring Diagram.
	2. Electric float switch on pump	2. Check position of the actuators on the electric float switch.
	3. Dirty pump	3. Clean pump. See Paragraph 2.3.7.
	4. Defective pump	4. Replace pump.
Float & Pump Control System - Required water level (3") not maintained	1. Float valve	1. Adjust float valve. Refer to the installation manual.
	2. Optional drain and fill valves	2. Check valve for proper operation.
	3. Incorrect overflow pipe nipple - should be 3-1/2"	3. Replace pipe nipple.
	4. Drain leaking	4. Tighten drain plug.
Water running off of media pads	1. Excessive water flow 2. Media pads need cleaned or replaced.	1. Adjust ball valve in distribution line. Refer to installation manual. 2. Clean or replace media pads. See Paragraph 2.3.7.
Water not distributing evenly	1. Distribution line clogged	1. Flush distribution line. See Paragraph 2.3.7.
	2. Holes in distribution line turned	2. Check position of distribution line. Holes should be spraying upward. If not positioned with holes toward top, adjust position of PVC line.
	3. Incorrect voltage to pump (float and pump control system)	3. Check voltage at pump terminal in cooling module junction box.
Media pads becoming clogged and discolored quickly (scale/salt deposits) and/or rapid deterioration of the float switch (Float and Pump Control System)	1. Bleed off line clogged	1. Clean bleed line.
	2. Excessive water flow	2. Reduce flow by adjusting ball valve in distribution line. Refer to installation manual.
	3. Inadequate bleed off	3. A uniform build-up of minerals on the entering air face of the media indicates insufficient bleed off. Increase the rate until the mineral deposits dissipate.
Water blowoff from media pads or water being pulled from reservoir	1. Media pads installed incorrectly	1. Install media pads correctly. See Paragraph 2.3.7.
	2. Requires moisture elimination pad (over 600 FPM)	2. Install moisture elimination pad. Consult factory.
	3. Water level not 3 inches (float and pump control system)	3. See second problem listed above (Required water level not being maintained.)

Additional References

See your Factory Distributor for the following forms:

- Installation - **Form I-ADF (P/N 131805)**
- Installation - **Form I-RDF (P/N 148384)**
- Replacement Parts - **Form P-ADF/ADFH (P/N 270068)**
- Replacement Parts - **Form P-RDF (P/N 270069)**
- Replacement Valves & Ignition Controls by Serial No. Code - **Form P-VALVES (P/N 263995)**

INDEX

- A**
 - Air Pressure 5
 - Air Pressure Switches 9
 - Amplifier 12
- B**
 - Blower Belts 4
 - Belt Tension 4
 - Blower Bearings 4
 - Bulbs 5, 9
 - Burner 11
 - Main Burner 5
 - Bypass Damper Airflow 10
- C**
 - Circuit Indicator Board 5
 - Control Locations 8
- D**
 - Damper Motor 15
 - Dampers 15
 - Diagnostic Circuit Board 9
 - Direct-Fired Burner 11, 12, 14
 - Door Switch 17
 - Drive Components 4
- E**
 - Electronic Circuit Board with Lights 8
 - Electronic Modulation 11
 - Emergency Cut Off 9
 - End Plate 5
 - Evaporative Cooling Media 6
 - Evaporative Cooling Module 6
- F**
 - Dirty Filter Switch 17
 - Filters 4
 - Firestat 17
 - Flame Sensor 10
- G**
 - Gas Controls 14
 - Gas Pressure 4
 - Gas Pressure Switch 15
 - Gas Train 11
- H**
 - HAZARD INTENSITY LEVELS 2
 - Hot Surface Ignition System 10
- I**
 - Ignition System 10
 - Ignitor 10
 - Inlet Air Controls 15
- J**
 - Junction Box 7
- L**
 - Automatic Reset Limit Control 9
 - Manual Reset Limit Control 9
 - Limit Safety Controls 9
 - Low Temperature Limit 17
- M**
 - Maintenance Codes 3
 - Maintenance Schedule 3, 6, 8
 - Manifold Arrangements 14
 - Maxitrol Series 14 Components 12, 13
 - Maxitrol Series 44 Components 12, 14
 - Mixing Plates 5
 - Mixing Tube 12
 - Electronic Modulation Makeup Air 13
- O**
 - Outside Air Cutoff Control 16
- P**
 - Photoelectric Smoke Detector 17
 - Photohelic Pressure Switch 16
 - Pilot Assembly 5
 - Potentiometer 16
 - Supply Pressure 14
 - Airflow Sensing Pressure Check 10
 - Pressure Null Switch 16
 - Pressure Switch 10
- R**
 - Remote Sensor/Selector 14
- S**
 - Signal Conditioner 13
- T**
 - Temperature Selector 12
 - Troubleshooting 18
- V**
 - Modulating Gas Valve 12, 13
 - Single-Stage Gas Valve 11
 - Two-Stage Gas Valve 11
- W**
 - Warnings 2

Specifications & illustrations subject to change without notice and without incurring obligations.

©Nortek Global HVAC, LLC 2015. All rights reserved.

All marks are the property of their respective organizations.

O'Fallon, MO | Printed in U.S.A. (12/15)

Form O-ADF/RDF (12-15), PN 148385R3