

OVEN WIRING

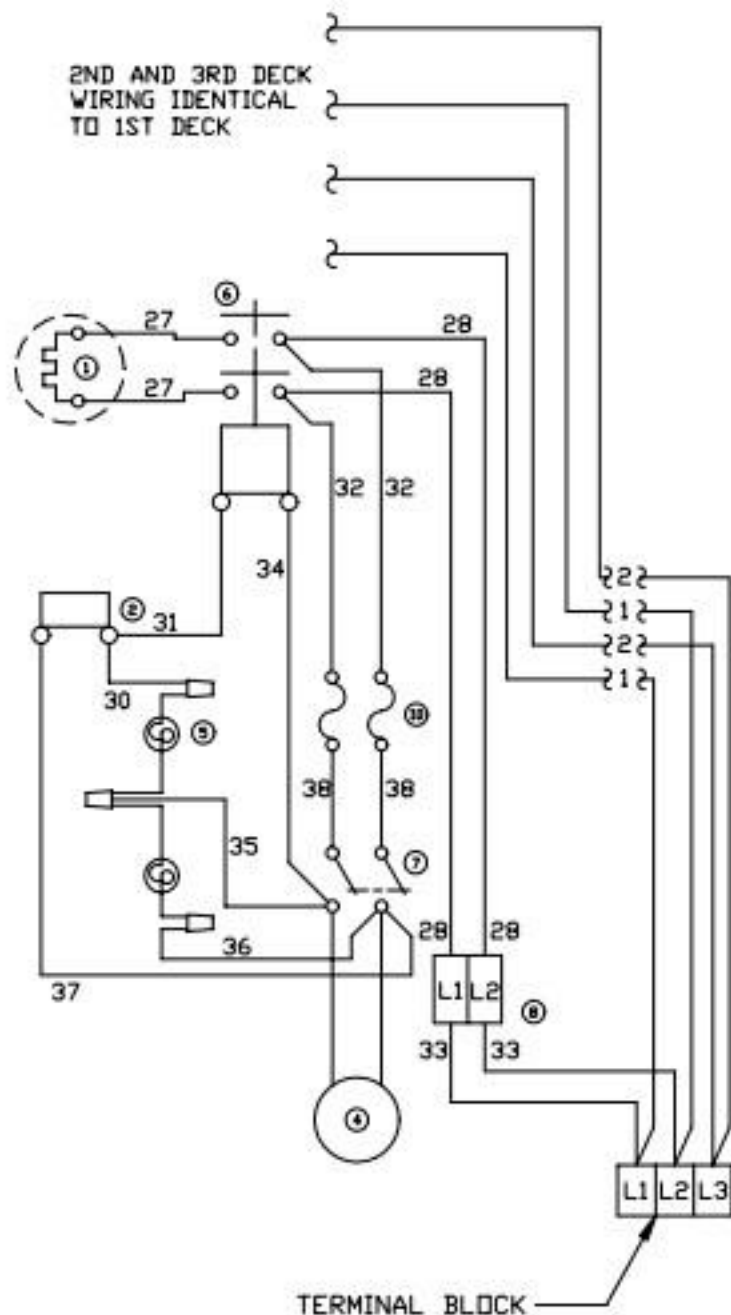

MODEL DESIGNATION

TOP ARRANGEMENT

TOP SECTION WIRE DIAGRAMS

RF219-A  
RF219-C  
RF219-D  
RF219-G  
RF219-H

SEC-1	SEC-2	SEC-3
A	A	C
B	B	B
B	B	C
A	A	A
C	C	C

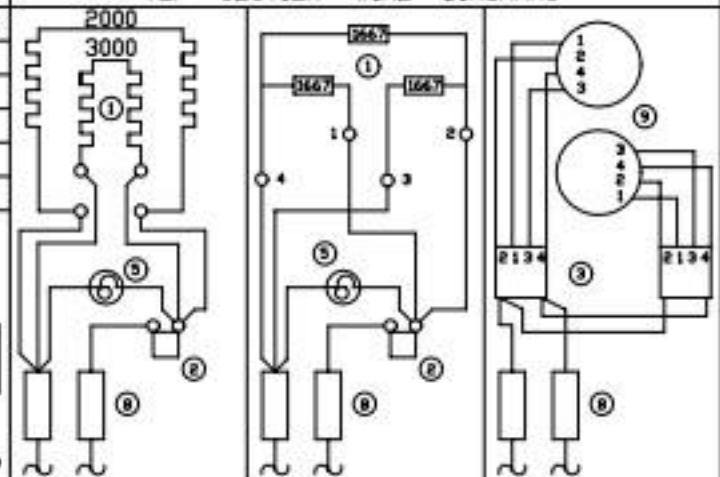

- ① HEAT ELEMENT
- ② THERMOSTAT
- ③ 6 HEAT SWITCH
- ④ MOTOR
- ⑤ PILOT LAMP
- ⑥ CONTACTOR
- ⑦ POWER SWITCH
- ⑧ CIRCUIT BREAKER
- ⑨ SPEED UNIT
- ⑩ FUSE

A GRILL    B HOT TOP    C SPEED UNITS

ELECTRICAL CONNECTIONS

CONNECT WIRES FROM RANGE TOP OR ADDITIONAL DECKS TO LOWER OVEN TERMINAL BLOCK AS SHOWN AT RIGHT

POWER SUPPLY	TERMINAL BLOCK	RANGE TOP	OVEN		
			1st DECK	2nd DECK	3rd DECK
SINGLE PHASE	L1	1-3-5	1	1	1
	L2	2-4-6	2	2	2
THREE PHASE	L1	3	1	1	-
	L2	1-5	2	-	1
	L3	2-4-6	-	2	2

ELECTRICAL DATA

MODEL NUMBER	LOADING					KW TOTAL	THREE PHASE AMPS						SINGLE PHASE AMPS	
	KW PER PHASE						208 VOLT			240 VOLT			208V	240V
	L1	L2	L2	L3	L3		L1	L2	L3	L1	L2	L3		
RF-21S	6.6	10.0	5.0			21.6	48.3	69.2	62.5	41.9	59.9	54.2	103.8	90.0
1F-6S	6.6	0.0	0.0			6.6	31.7	31.7	00.0	27.5	27.5	0.0	31.7	27.5
2F-6S	6.6	0.0	6.6			13.2	55.0	31.7	31.7	47.7	27.5	27.5	63.5	55.0
3F-6S	6.6	6.6	6.6			19.8	55.0	55.0	55.0	47.7	47.7	47.7	95.2	82.5

USE ON ALL E SERIAL NUMBERS

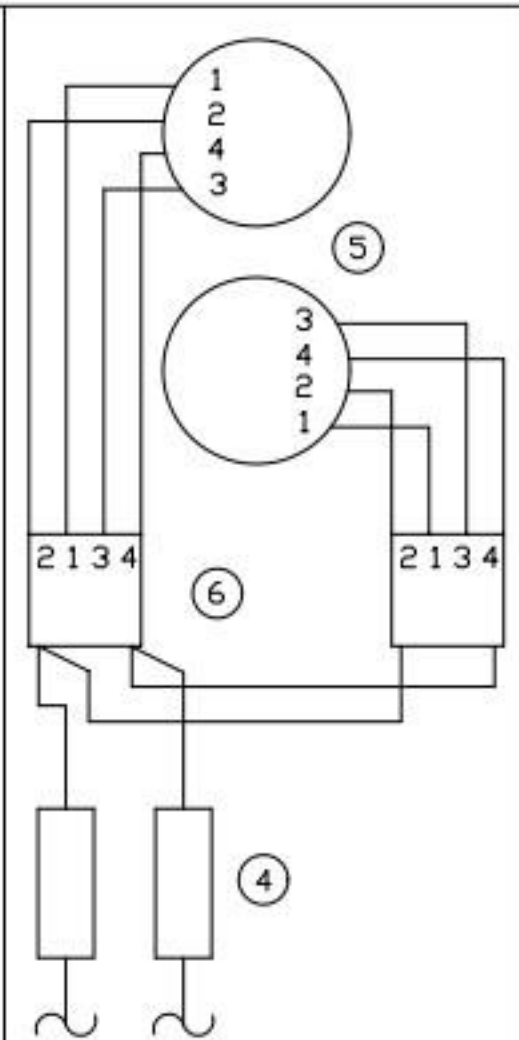
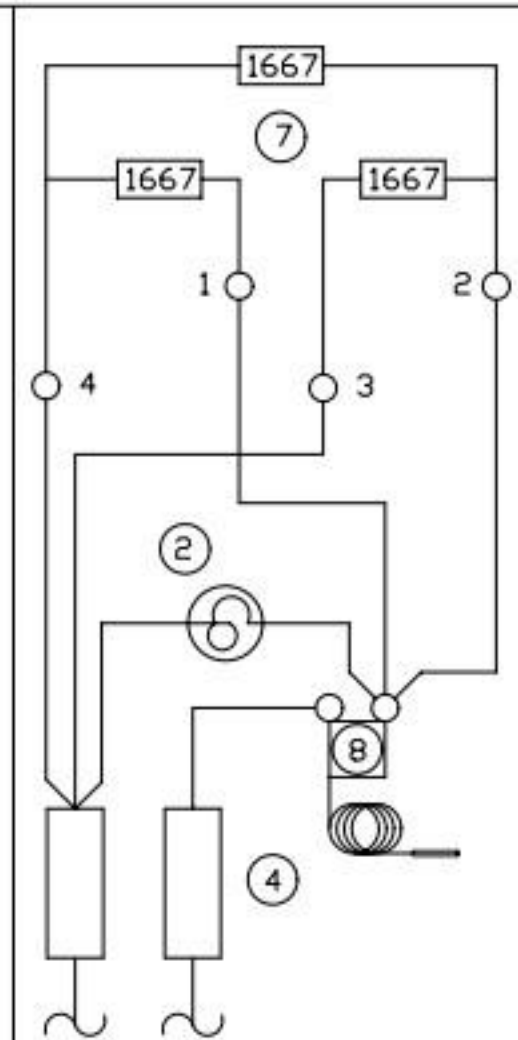
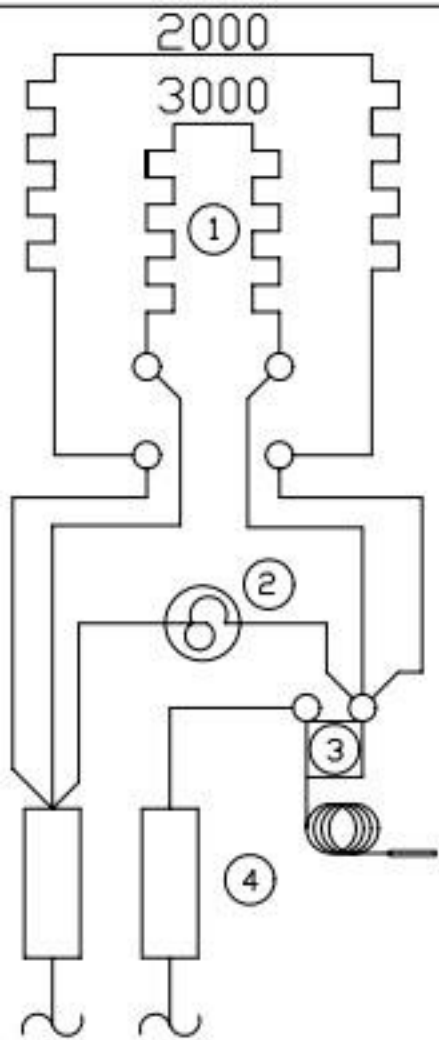

OVEN WIRING

2ND AND 3RD DECK WIRING IDENTICAL TO 1ST DECK

1ST DECK TERMINAL BLOCK

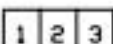

2ND DECK TERMINAL BLOCK

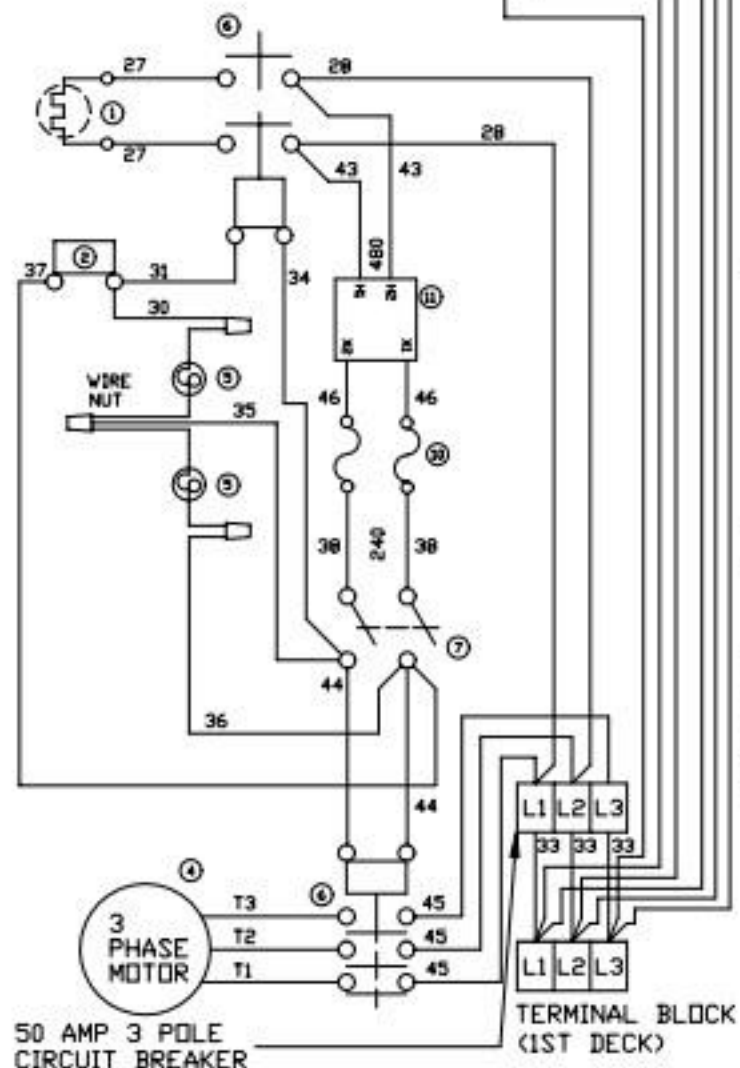
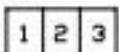

50 AMP 3 POLE CIRCUIT BREAKER

TERMINAL BLOCK (1ST DECK)

MODEL DESIGNATION

TOP ARRANGEMENT

SEC-1 SEC-2 SEC-3

RF21S-A	A	A	C
RF21S-C	B	B	B
RF21S-D	B	B	C
RF21S-G	A	A	A
RF21S-H	C	C	C

- ① HEAT ELEMENT
- ② THERMOSTAT
- ③ 6 HEAT SWITCH
- ④ MOTOR
- ⑤ PILOT LAMP
- ⑥ CONTACTOR
- ⑦ POWER SWITCH
- ⑧ SPEED UNIT
- ⑨ FUSE
- ⑩ TRANSFORMER

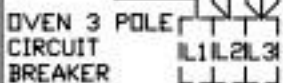

TOP SECTION WIRE DIAGRAMS

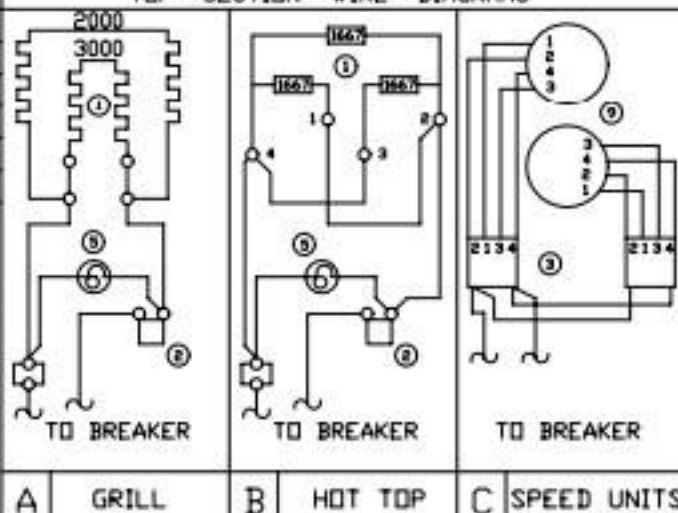

A GRILL B HOT TOP C SPEED UNITS

ELECTRICAL CONNECTIONS

CONNECT WIRE FROM RANGE TOP TO OVEN CIRCUIT BREAKER. CONNECT WIRES FROM ADDITIONAL DECKS TO LOWER OVEN TERMINAL BLOCK

POWER SUPPLY	RANGE TOP CONNECT TO OVEN CIRCUIT BREAKER	UPPER OVENS CONNECT TO BOTTOM DECK TERMINAL BLOCK		
		1st DECK	2nd DECK	3rd DECK
THREE PHASE	L1	3	1	2
	L2	1-5	2	3
	L3	2-4-6	3	1

CONVECTION OVEN/RANGE ELECTRICAL DATA

MODEL NUMBER	LOADING			TOTAL CONN. LOAD	AMPS THREE PHASE 480 VAC		
	KW/PHASE				L1	L2	L3
	L1 L2	L2 L3	L3 L1				
RF-21S	6.2	10.2	5.2	21.6	20.1	29.5	27.7
1F-6S	6.2	0.2	0.2	6.6	13.2	13.2	.66
2F-6S	6.4	0.4	6.4	13.2	23	13.9	13.9
3F-6S	6.6	6.6	6.6	19.8	23.6	23.6	23.6

CAUTION: CHECK OVEN FOR PROPER DIRECTION OF FAN ROTATION

CHANGE PHASING OF POWER IF NECESSARY TO CORRECT

USE ON ALL E SERIAL NUMBERS