

ROYALTON SS1 & SS2 RRH OVEN



Royalton Foodservice
Equipment Company



Royalton Foodservice
Equipment Company

9981 York-Theta Drive, North Royalton, Ohio 44133
440-237-0806 FAX: 440-237-1694 1-800-662-8765

WARRANTY

ROYALTON FOODSERVICE EQUIPMENT COMPANY WARRANTS TO THE ORIGINAL PURCHASER THAT ANY ORIGINAL PART FOUND TO BE DEFECTIVE IN MATERIAL OR WORKMANSHIP WILL BE REPLACED AT OUR DISCRETION WITHIN ONE (1) YEAR FROM DATE OF SHIPMENT.

IF AUTHORIZED BY OUR SERVICE DEPARTMENT, REPLACEMENT PARTS ARE PROVIDED F.O.B. FACTORY. THIS WARRANTY ALSO PROVIDES ONE (1) YEAR LABOR, FROM DATE OF SHIPMENT. END-USER OR RESPONSIBLE PARTY MUST NOTIFY ROYALTON FOOD SERVICE EQUIPMENT CO. FIRST WITH A MODEL AND SERIAL NUMBER AND WHAT TYPE OF PROBLEM IS OCCURRING. AT THAT TIME AUTHORIZATION WILL BE GIVEN AND PARTS WILL BE SENT TO THE END-USER OR SERVICE AGENCY. IF THIS PROCEDURE IS NOT FOLLOWED, END-USER WILL BE RESPONSIBLE FOR SERVICE LABOR & TRAVEL BILL.

OUR TUBULAR HEATERS HAVE A WARRANTY OF FIVE (5) YEARS. WITHOUT PRIOR AUTHORIZATION FROM OUR SERVICE DEPARTMENT, PARTS CANNOT BE RETURNED TO US FOR CREDIT. CREDIT IS SUBJECT TO APPROVAL BY OUR SERVICE DEPARTMENT AFTER INSPECTION OF RETURNED PARTS.

THIS WARRANTY DOES NOT INCLUDE LABOR AND DOES NOT APPLY TO: DAMAGED EQUIPMENT CAUSED BY SHIPPING ACCIDENTS, IMPROPER STORAGE, INADEQUATE MAINTENANCE, NEGLIGENCE, MISAPPLICATION, UNAUTHORIZED ALTERATIONS, LOSSES OR DAMAGES RESULTING FROM MALFUNCTIONS, INCLUDING LOSS OF PRODUCT, IMPROPER INSTALLATION - NO FRYERS, BROILERS, COOK TOPS, OR ANY KIND OF HEAT SOURCE SHOULD BE PLACED ON THE RIGHT SIDE OF THE EQUIPMENT. GLASS, LIGHT BULBS, DOOR AND BODY GASKETS, AND MEAT PROBES ARE NOT COVERED UNDER OUR WARRANTY.

THIS WARRANTY IS IN LIEU OF ALL WARRANTIES EXPRESSED OR IMPLIED.

FOR WARRANTY SERVICE, PLEASE CONTACT CUSTOMER SERVICE AT ROYALTON FOODSERVICE EQUIPMENT COMPANY @ 800-662-8765



Royalton Foodservice Equipment Company

9981 York-Theta Drive, North Royalton, Ohio 44133
440-237-0806 FAX: 440-237-1694 1-800-662-8765

CARE AND CLEANING

The unit should be wiped down, inside and out, after each use. The control module should be checked for dust, grime, or grease around the vent louvers and wiped on a regular basis. Because the roasting is done at low temperatures, there is very little grease build-up. Over time, however, grease will begin to stick to the walls and floor of the unit. Hot soapy water with a non-abrasive pad or oven cleaner for stainless steel is best for cleaning the interior. For the exterior, we recommend hot soapy water with a non-abrasive pad, or stainless steel cleaner and polish. Always wipe with the grain. Failure to remove greasy build-up can cause bacterial growth within the oven cavity. It can also impair the accuracy of the temperature sensors that keep the heat cycling properly.

- **DO NOT** use a pressure washer or water under pressure. Avoid getting water inside the control module, because it ruins the electrical components and **VOIDS THE WARRANTY**.
- **NEVER** locate your Royalton unit next to grease emitting equipment such as deep fryers or griddles.
- **DO NOT** block louvers or cooling fans in the control module. Doing so will cause the unit to overheat and shut down the oven.

CLEANING PROCEDURE

1. Press power switch off
2. Unplug power cord.
3. Remove interior parts for cleaning (side racks, pan slides, drip pan).
4. Clean interior and exterior.
5. Replace interior parts.
6. Plug in power cord.



**Royalton Foodservice
Equipment Company**

9981 York-Theta Drive, North Royalton, Ohio 44133
440-237-0806 FAX: 440-237-1694 1-800-662-8765

VENTING

IN GENERAL, THIS APPLIANCE DOES NOT NEED TO BE PLACED UNDER A HOOD. CONSULT YOUR LOCAL HEALTH AND FIRE CODES FOR REQUIREMENTS IN YOUR AREA

DO NOT LOCATE APPLIANCE UNDER AN OVERHEAD VENT HOOD CLOSE TO OTHER COOKING EQUIPMENT BECAUSE:

1. Fumes and grease particles generated by other cooking equipment would possibly be drawn by the cooling fans into the control compartment of the top mounted heating module.
2. Fumes and deposition of grease particles within the control compartment must be avoided in order to assure top performance and long product life.

***** VERY IMPORTANT *****

IN ORDER TO ASSURE AIR FLOW THROUGH HEATING MODULE, DO NOT POSITION OVEN FLUSH AGAINST ANY WALLS. MAINTAIN A MINIMUM GAP OF 2 INCHES BETWEEN OVEN CABINET AND WALLS. IF YOU PLACE OVENS SIDE BY SIDE, MAINTAIN A MINIMUM OF A 4 INCH GAP BETWEEN CABINETS.



Royalton Foodservice Equipment Company

9981 York-Theta Drive, North Royalton, Ohio 44133
440-237-0806 FAX: 440-237-1694 1-800-662-8765

STACKING KITS

PLACE TOP CABINET, WITH NO BASE AND NO CASTERS, ON TOP OF BOTTOM CABINET WITH BASE AND CASTERS.

LINE UP THE TOP CABINET'S BACK END WITH THE BACK END OF THE BOTTOM CABINET. INSTALL 3 SCREWS ON EACH SIDE OF THE STACKING KIT (LOOSELY MOUNTED) START ALL SCREWS THEN TIGHTEN DOWN FOR FINAL ASSEMBLY.

NOTE: STACKED UNITS HAVE TWO POWER CORDS.

STACKING UNITS

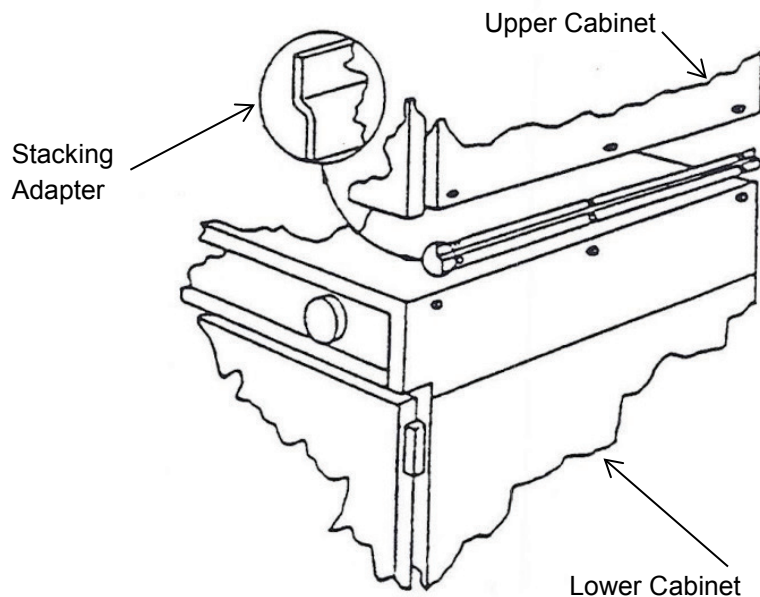



Royalton Foodservice Equipment Company

9981 York-Theta Drive, North Royalton, Ohio 44133
440-237-0806 FAX: 440-237-1694 1-800-662-8765

OPERATING INSTRUCTIONS FOR SS2-KNOB CONTROLLER

TO COOK USING TIMER:

- 1.) POWER SWITCH ON.
- 2.) SET COOK TEMP. (KNOB)
- 3.) SET HOLD TIME. (KNOB)
- 4.) ALARM SOUNDS WHEN PRE-HEATED (PRESS CLEAR ALARM).
- 5.) LOAD OVEN WITH PRODUCT.
- 6.) SET COOK TIME $\Delta \nabla$
- 7.) PRESS START.

TO COOK USING PROBE:

- 1.) POWER SWITCH ON .
- 2.) SET COOK TEMP. (KNOB)
- 3.) SET HOLD TEMP. (KNOB)
- 4.) ALARM SOUNDS WHEN PRE-HEATED (PREES CLEAR ALARM).
- 5.) PLUG IN PROBE.
- 6.) SET COOK-TO TEMPERATURE $\Delta \nabla$
- 7.) LOAD PRODUCT AND INSERT PROBE.
- 8.) PRESS START.

Note: With the completion of the cook-probe/rethermalizing cycle, the oven will automatically go into the hold cycle and the clock will start to register the amount of time your product has been holding..

VERY IMPORTANT

Never taker refrigerated or frozen product and try to rethermalize while the oven is in the hold cycle.

ERROR CODES:

'E-1 indicates an RTD malfunction - to repair, replace RTD.

"E-2" indicates parameter data recorded in programming mode may be corrupted - power down unplug (about 1 minute) plug back in, power up.

"E-3' indicates the logged data after a power failure was not logged properly - same as above.

SS1 OVEN OPERATION

To Set Clock

Note: Clock Must Be Set to Operate Oven

1. Press Or/Off to Off (No Light)
2. Press Enter in Time Area for 3 Seconds
3. Press Arrow $\Delta \nabla$ Keys for Correct Day
4. Press Enter
5. Press Arrow $\Delta \nabla$ Keys for 12or 24Hr. Setting
6. Press Enter
7. Press Arrow $\Delta \nabla$ Keys to Correct Time
8. Press Enter

Procedures If Power Loss Occurs

1. Press Clear to Stop Alarm
2. Press Start/Stop
3. Press Clear for 3 seconds (3 Beeps will Sound)
4. Press Arrow $\Delta \nabla$ Keys in Time to Illustrate Time & Temperature when Power Loss Occurred

To Erase Power Loss Info

1. Press & Hold Enter in Time Area for 3 Seconds (3 Beeps will Sound)

To Pre-Heat Cook & Hold Solid-State Digital Control

Note: Clock Must be Set to Operate Oven
See: To Set Clock

1. Press Power On
2. Press Pre-Heat
3. Press Arrow $\Delta\nabla$ in Temp Area to Desired Temperature and Press Enter. Note: If Enter is not Pressed Within 5 Seconds Temperatures and Times will Revert to Previous Settings
4. Press Roast
5. Press Arrow $\Delta\nabla$ in Temp Area to Desired Cook Temperature and Press Enter
6. Press Arrow $\Delta\nabla$ in Time Area to Desired Cook Time and Press Enter
7. Press Hold
8. Press Arrow $\Delta\nabla$ in Temp Area to Desired Hold Temperature and Press Enter
9. Press Pre-Heat and Start
Note: Oven Beeps when Pre-Heated- Press Clear to stop Beeps
10. Load Oven- Press Start/Stop- Press Roast- Press Start

Note: Oven will Cycle to Hold when Cook Time is Done & Begin Counting up Hold Time

SETTING PROGRAM SELECT

1. Press Power On
2. Press Select to Light First Label Area
3. Press Pre-Heat
4. Press Arrow $\Delta\nabla$ Temp Area to Desired Temperature and Press Enter
5. Press Roast
6. Press Arrow $\Delta\nabla$ in Temp Area to Desired temperature and Press Enter
7. Press Arrow $\Delta\nabla$ in Time Area to Desired cook Time and Press Enter Note: If cooking by Probe Rather than Time, Press Probe - Press Arrow $\Delta\nabla$ in Temp Area to Desired Temperature & Press Enter
8. Press Hold
9. Press Arrow $\Delta\nabla$ in Temp to Desired Hold temperature And Press Enter
10. Press and Hold Select for 3 Seconds to Store in Memory

Note: To Store other Menu Programs Repeat Steps 2 thru 10

To Pre-Heat Cook & Hold **Using Program Select**

1. Press On
2. Press Select to Light Desired Program
3. Press Pre-Heat and Press Start
Note: Oven Beeps When Pre-Heated
Press Clear to Stop Beeps
4. Load Product Into Oven
5. Press Start/Stop to Stop Pre-Heat
6. Press Roast and Press Start/Stop

To Set Auto Pre-Heat

1. Press On
2. Press and Hold Auto Pre-Heat for 3 Seconds
3. Press Arrow Δ ∇ in Time Area for Desired Day
And Press Enter
4. Press Arrow Δ ∇ in Time Area for Desired Time
And Press Enter
5. Press Arrow Δ ∇ in Temp Area for Desired Pre-Heat
Temperature and Press Enter
6. Press Auto Pre-Heat to Exit
Note: To Auto Pre-Heat Other Days, Repeat Steps
2 thru 5

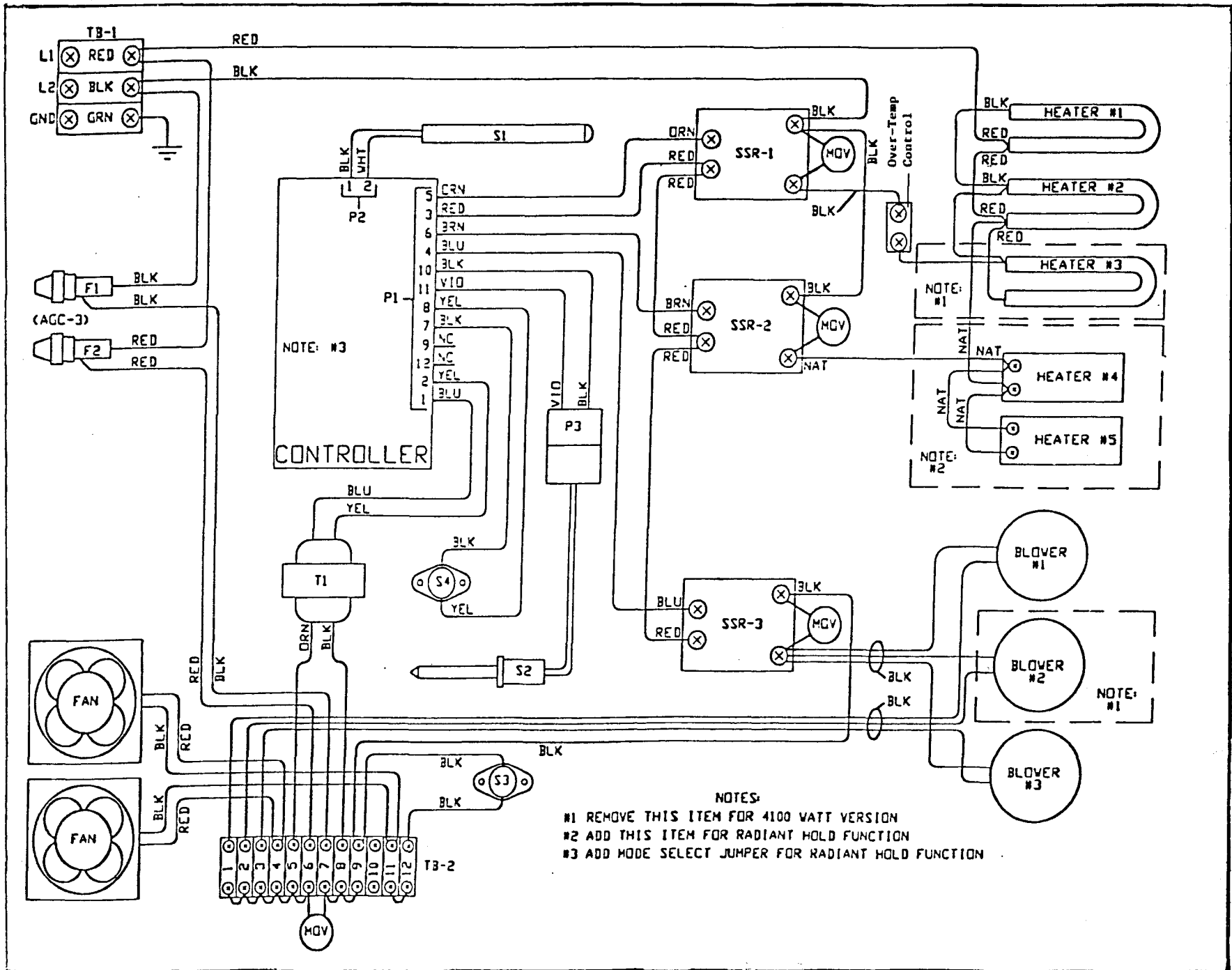

NOTE: #3

CONTROLLER

NOTE: #1

NOTE: #2

NOTE: #1

NOTES:

- #1 REMOVE THIS ITEM FOR 4100 WATT VERSION
- #2 ADD THIS ITEM FOR RADIANT HOLD FUNCTION
- #3 ADD MODE SELECT JUMPER FOR RADIANT HOLD FUNCTION

ROYALTON FOODSERVICE EQUIPMENT COMPANY PARTS LIST

<u>PART#</u>	<u>DESCRIPTION</u>	<u>VOLTS</u>	<u>MODEL SERIES</u>
223	R/C NETWORK - SURGE PROTECTION	120	RHHC, RHHR, RHHP-VT RHHT, RPC-US
278	CONTACTOR - ASK COIL VOLTAGE	208-240	RRH
284	ROAST KNOB		RRH, SS2RRH
288	R/C NETWORK - SURGE PROTECTION	208-240	RRH
289	BLUE TIMER KNOB		RRH
670	HEAVY DUTY PLUG 30 AMP OR 50 AMP	208-240	RRH, SS1 & SS2RRH
761	FUSE	208-240	RRH, SS1 & SS2RRH
917	MEAT PROBE JACK		SS2RRH
967	FUSE HOLDER	208-240	RRH, SS1 & SS2RRH
923	THERMOSTAT KNOB		RHH, RSH, RCS
955	BASE RECEPTACLE	120	RSH
965	HEAT FUSE KIT	120	RHH
966	HEAT FUSE KIT	208-240	RRH
968	BLOWER MOTOR ASSEMBLY KIT	208-240	RRH
968A	BLOWER MOTOR ASSEMBLY KIT (NO PLUGS)	208-240	SS1 & SS2 RRH
969	BLOWER MOTOR ASSEMBLY KIT	120	RHH
969A	BLOWER MOTOR ASSEMBLY KIT (NO PLUGS)	120	SSRHH, SSRHP-US
970	GASKET TOP BODY KIT (STRIP & STICK)		RRH, RHH
972	GASKET DOOR		C1 BODY
973	GASKET DOOR		C2 BODY
974	GASKET DOOR	PER DOOR	C4 BODY
993	GASKET DOOR	PER DOOR	C4US BODY
994	GASKET DOOR	PER DOOR	C4W BODY
975	GASKET DOOR		RSH-1206
976	GASKET DOOR		RSH-1209
977	GASKET DOOR		RSH-1806
978	GASKET DOOR		RSH-1809
980	HINGE FOR DOOR		ALL MODELS
1869	GASKET DOOR		RSH-1205
1637	GASKET DOOR		RSH-2106
1641	GASKET DOOR		RSH-2104
1644	GASKET DOOR	ONE DOOR	C3 BODY
2382	GASKET DOOR	ONE DOOR	RHP-US, RPC-US
1035	CASTER 3-1/2" SWIVEL		RSH
1036	CASTER 3-1/2" SWIVEL w/BRAKE		RSH
1037	CASTER 5" SWIVEL		RHH,RRH,SS1&SS2 RRH,RSH
1038	CASTER 5" SWIVEL w/BRAKE		RHH,RRH,SS1&SS2 RRH,RSH
1888	CASTER 6" SWIVEL		SSRHHP-VT-C4US

1887	CASTER 6" SWIVEL W/BRAKE		SSRHHP-VT-C4US		
62	COOLING FAN	120	RRH, SS1 & SS2RRH, SSRHHP-VT-C4US		
1039	COOLING FAN	208-240	RRH, SS1 & SS2RRH,		
1040	HEAT ELEMENT 2600W (SPECIFY 220V OR 240V)	208-240	RRH, SS1 & SS2RRH,		
1043	HEAT ELEMENT 1900W (SPECIFY 220V OR 240V)	208-240	RRH, SS1 & SS2RRH,		
1044	HEAT ELEMENT 1000W	120	RHH C1 & C2		
1045	HEAT ELEMENT 1800W	120	RHH C3, C3US, C3W RHH C4, C4US, C4W		
979	HEATER STRIP 400W	120	RSH, SSRSH, RCS		
1296	HEATER STRIP 150W	120	SSRSH, RSH		
1645	HEATER STRIP 700W	120	RHP		
1646	HEATER STRIP 800W	120	RHP		
1686	HEATER STRIP 500W	120	SSRHP, SSRSH, SS1 & SS2RRH		
1687	HEATER STRIP 500W	208-240	SS1RRH, SS2RRH		
1041	CORD GRIP	208-240	RRH, SS1 & SS2RRH,		
1042	CORD GRIP	120	RHH		
1046	LATCH MAGNETIC/MECHANICAL w/LOCK		ALL MODELS		
1047	LATCH MAGNETIC/MECHANICAL w/o LOCK		ALL MODELS		
668	STRIKE PLATE FOR ABOVE LATCH ASSEMBLY		ALL MODELS		
1048	PILOT LIGHT - AMBER (ROAST/HOLD)	208-240	RRH		
1049	PILOT LIGHT - RED (HEAT)	120, 208-240	RRH, RHH, RSH		
1050	POWER CORD w/PLUG - 15 AMP	120	RHH 1000W TOPS		
1051	POWER CORD w/PLUG - 20 AMP	120	RHH 2000W TOPS		
1052	POWER CORD w/PLUG - 50 AMP	208-240	RRH 6100W TOPS		
1053	POWER CORD w/PLUG - 30 AMP	208-240	RRH 4100W TOPS		
1054	POWER CORD SET COMPLETE - 15 AMP	120	RSH, SSRSH, RHP, SSRHP, RHR, SSRHR		
1055	SWITCH, ON-OFF	120, 208-240	RRH, RHH, RSH, RHP, RSW, RCS		
1056	SWITCH FOR ROAST TIMER	208-240	RRH		
1057	TEMPERATURE PROBE 350 DEG.	208-240	RRH		
1057A	TEMPERATURE PROBE 350 DEG.	208-240	SS1 & SS2 RRH		
1058	THERMOMETER		RHH, RSH		
1059	THERMO-SWITCH FOR COOLING FANS	120, 208-240	RHHP-VT, RRH, SS1&SS2RHH		
1060	THERMOSTAT	120	RHH, RSH, RCS, RHP		
1061	THERMOSTAT (TEMPERATURE CONTROL BOARD) 350 DEG. ROAST, 250 DEG. HOLD w/POTENTIOMETERS	120, 208-240	RRH		
1062	TERMINAL BLOCK 3-POLE	208-240	RRH, SS1RRH, SS2RRH		
1063	TERMINAL BLOCK 6-POLE	120, 208-240	RHH, RRH, SS1 & SS2RRH		
1064	TIMER	208-240	RRH		
1151	1" LEG w/RUBBER BOOT				
1166	4" LEG				
1188	CAM w/SCREW				

1357	SS1 OVEN CONTROLLER (CPU BOARD)	208-240	SS1RRH	
1358	SS1 OVEN CONTROLLER (DISPLAY BOARD)	208-240	SS1RRH	
1363	M.O.V.	120, 208-240	SS1RRH, SS2RRH, SSRHH SSRHP, SSRSH, SSRHHP-VT'S	
1378	50-AMP SOLID STATE RELAY w/M.O.V.	120, 208-240	ALL MODELS	
1379	25-AMP SOLID STATE RELAY w/M.O.V.	120, 208-240	SS1RRH, SS2RRH	
1387	SNAP SWITCH - O.T. DEVICE	208-240	SS1RRH, SS2RRH	
1389	TRANSFORMER (240-12)	208-240	SS1RRH, SS2RRH	
1394	MEAT PROBE		SS1RRH, SS2RRH	
1501	12 POLE TERMINAL BLOCK	208-240	SS1RRH, SS2RRH	
1595	TEMP PROBE RTD 2K	120	SSRHH, SSRHP, SSRSH SSRHHP-VT, SSRPC	
1601	SS ELECTRONIC CONTROLLER AIR	120	SSRHH, SSRHP, SSRSH SSRHHP, SSRPC	
1601A	AIR TEMPERATURE CONTROL BOARD	120	SSRHH-VT, SSRHP-US	
1601B	WATER TEMPERATURE CONTROL BOARD	120	SSRHH-VT, SSRHP-US	
1602	TRANSFORMER (120-12)	120	SSRHH, SSRHP, SSRSH SSRHHP, SSRPC	
1607	SWITCH - SPST ROCKER	208-240	SS2RRH	
1626	SS2 ELECTRONIC CONTROLLER	208-240	SS2RRH	
1632	POWER CORD w/PLUG, 8/3, 50 AMP	208-240	SS1RRH, SS2RRH - 8100W RRH-8100W	
1639	30-AMP O.T. DEVICE	208-240	SS1RRH, SS2RRH 4100W & 6100W	
1640	HEAT FUSE KIT 40 AMP O.T. DEVICE	208-240	SS1RRH, SS2RRH - 8100W	
1661	LATCH MAGNETIC/MECHANICAL w/LOCK INSULATED HANDLE		SS1RRH, SS2RRH, RRH	
1691	DOOR VENT KNOB		RRH, RHH, RSH	
1694	POWER CORD SET COMPLETE - 20 AMP	120	RHP, SSRHP, RHHR, SSRHHR 2000W	
1695	BASE RECEPTACLE - 20 AMP	120	SSRHP	
1696	LAMP-250W, 120V	120	RCS	
1702	POWER CORD w/PLUG, 14/3, 5-15, 72" LONG	120	RCS, RSW	
1731	BULBS		RSW	
1742	HEAT ELEMENT - TUBULAR (AIR) 1000W	120	SSRHH-VT-C2US	
1743	HEAT ELEMENT (HAIRPIN) 250W	120	RSW	
1744	HEAT ELEMENT (STRAIGHT) 250W	120	RSW	
1745	SNAP BUSHING		RSW	
1746	CORD GRIP		RSW	
1747	KNOB-BLACK		RSW	
1748	CAP FOR KNOB-BLACK WITH WHITE INDICATOR		RSW	
1749	THERMOSTAT	120	RSW	
1750	PORCELAIN SNAP IN SOCKET WITH 8" LEADS	120	RSW	

1751	HEATER BRACKET GUARD		RSW
1752	1/8" CLEAR TEMPERED GLASS 13-3/4"WX20-1/4"H	FOR 30" & 40"	RSW
1753	ALUMINUM FOIL TAPE 2"WX60 YARDS LONG		RSW
	3 MIL BACKING		
1754	WIRE NUT - YELLOW		RSW
1755	WIRE NUT - BLUE		RSW
1756	WIRE NUT - ORANGE		RSW
1757	SCREW 10/32X3/8"F SELF TAPPING SS410- PHILLIPS TRUSS HEAD		RSW, RSH-1205
1758	SCREW 10/32X3/8"F SELF TAPPING SS410- PHILLIPS PAN HEAD		RSW, RSH-1205
1759	SCREW 8/32X3/8"F SELF TAPPING SS410- PHILLIPS TRUSS HEAD		RSW, RSH-1205
1760	LEVITON PORCELAIN LAMP HOLDER - MEDIUM BASE, KEYLESS 660W, 250V	120	RCS-1800 OR 2600 SERIES
1761	CORD GRIP 1/2" NPT (CABLE DIA .24" TO .47")		RCS-1800 OR 2600 SERIES
1762	CUTTING BOARD - 18X24X1/2		RCS-1800 OR 2600 SERIES
1763	GOOSENECK CHROME PLATED 9"X.585 1/8X1/8M		RCS-1800 OR 2600 SERIES
1764	RELAY 275F, 120V AC,DPDT 30A	120	RHH-VT-C2US/C4US SSRHHP, SSRPC
1765	PROBE-WATER BATH. RTD2K 22"LONG SS9'LEADS	Original	RHH-VT-C2US/C4US
1765A	PROBE-WATER BATH, RTD2K-NEW UNIT w/SUMP		RHH-VT-C2US/C4US SSRHHP, SSRPC
1766	HEAT ELEMENT 1800W, 120V TUBULAR (AIR)	120	RHH-VT-C4US, SSRHHP, SSRPC
1767	HEAT ELEMENT 1800W, 120V TUBULAR (WATER) NEW UNIT W/SUMP	120	RHH-VT-C3US, C4US, SSRHHP
1767A	HEAT ELEMENT 1800W, 120V TUBULAR (WATER) ORIGINAL (S.S. WATER PAN SITS ON FLOOR)	120	RHH-VT-C4US
1768	HEAT ELEMENT 1000W, 120V TUBULAR (WATER)	120	RHH-VT-C1US, C2US, SSRHHP
830	DECAL - ROYALTON COOK/HOLD STANDARD		RRH
831	DECAL - ROYALTON COOK/HOLD US		RRH
832	DECAL - ROYALTON COOK/HOLD WIDE		RRH
833	DECAL - ROYALTON HEAT/HOLD STANDARD		RHH
834	DECAL - ROYALTON HEAT/HOLD US		RHH
835	DECAL - ROYALTON HEAT/HOLD WIDE		RHH
839	DECAL - ROYALTON SATELLITE		RSH-1200 SERIES - 1205, 1206, 1208, 1209
840	DECAL - ROYALTON SATELLITE		RSH-1806, 1809
1094	DECAL - ROYALTON SATELLITE		RSH-2104, 2106
1310	DECAL - ROYALTON DIGITAL COOK/HOLD		SS1
1592	DECAL - ROYALTON KNOB COOK/HOLD		SS2

1593	DECAL - ROYALTON DIGITAL SATELLITE		SSRSH	
1594	DECAL - ROYALTON DIGITAL HEAT/HOLD		SSRHH, SSRHP	
1673	DECAL - ROYALTON SHELF WARMER		RSW-30-2	
1676	DECAL - ROYALTON CARVING STATION		RCS-1800-2	
1727	DECAL - ROYALTON DUAL DIGITAL (HUMIDITY)		SSRHH-VT	
1885	HINGE COVER ONLY		ALL MODELS	
1889	GASKET DOOR		RSH-1208	
1890	GASKET DOOR	PER DOOR	C-3	
1891	GASKET DOOR		C1US	
1892	GASKET DOOR		C2US	
1893	GASKET DOOR	PER DOOR	C3US	
1895	GASKET DOOR		C1W	
1896	GASKET DOOR		C2W	
1897	GASKET DOOR	PER DOOR	C3W	
1898	GASKET DOOR		RSH-2109	
1901	GASKET DOOR		RSH-1808	
2054	LATCH MAGNETIC (OFFSET HANDLE) INSULATED		SS1RRH, SS2RRH, RRH	
2216	GASKET DOOR (DUTCH DOORS)	PER DOOR	SSRHP-US, SSRPC-US	
2217	GASKET DOOR (SINGLE DOOR)		SSRHP-US, SSRPC-US	
2265	POWER CORD SET COMPLETE - 30 AMP (CANADA)	120	RHP, SSRHP, RHHR, SSRHHR 2000W	
2266	POWER CORD SET COMPLETE - 15 AMP	240	RSH, SSRSH, RHP, SSRHP, RHHR, SSRHHR UP TO 2000W	
2170	ABB TCSHAA MOTOR SENSING RELAY		R32BRTO-R14BRTO	
2174	AG-8 FUSE		R32BRTO	
2183	HEATING ELEMENT, 10,000 WATTS	208	R32BRTO	
2406	SPRING STEEL FOR DOOR GASKET-1 SET, 4 PCS.		R32BRTO	
1360	3-POLE CONTACTOR - ASK COIL VOLTAGE	208-240	SS1, SS2 RRH, SS2 RCRH	
460	R/C NETWORK - SURGE PROTECTION	208-240	RRH	
	C4 GLASS			
1929	DECAL ROYALTON PROFFER 7.312" X 21.50"	120	SSRHP-US/SSRPC-US	
2458	GASKET DOOR (LOW PROFILE)		R32BHHW	
2411	LATCH TOTAL MAGNETIC	STRIKE PLATE 7.80		
2403	CONTACTOR 3 POLE	208-240	RCRH-8135-C1US	
***ALL STAINLESS CABINET PARTS (INTERNAL & EXTERNAL) WILL BE SOLD FROM ROYALTON FOODSERVICE.				
***ALL STAINLESS TOP MODULE PARTS (INTERNAL & EXTERNAL) WILL BE SOLD FROM ROYALTON FOODSERVICE.				