

# Salvajor Model 200 2 HP - 3 Phase

## Series J Disposer Parts Breakdown

For Serial Numbers starting at: 80913

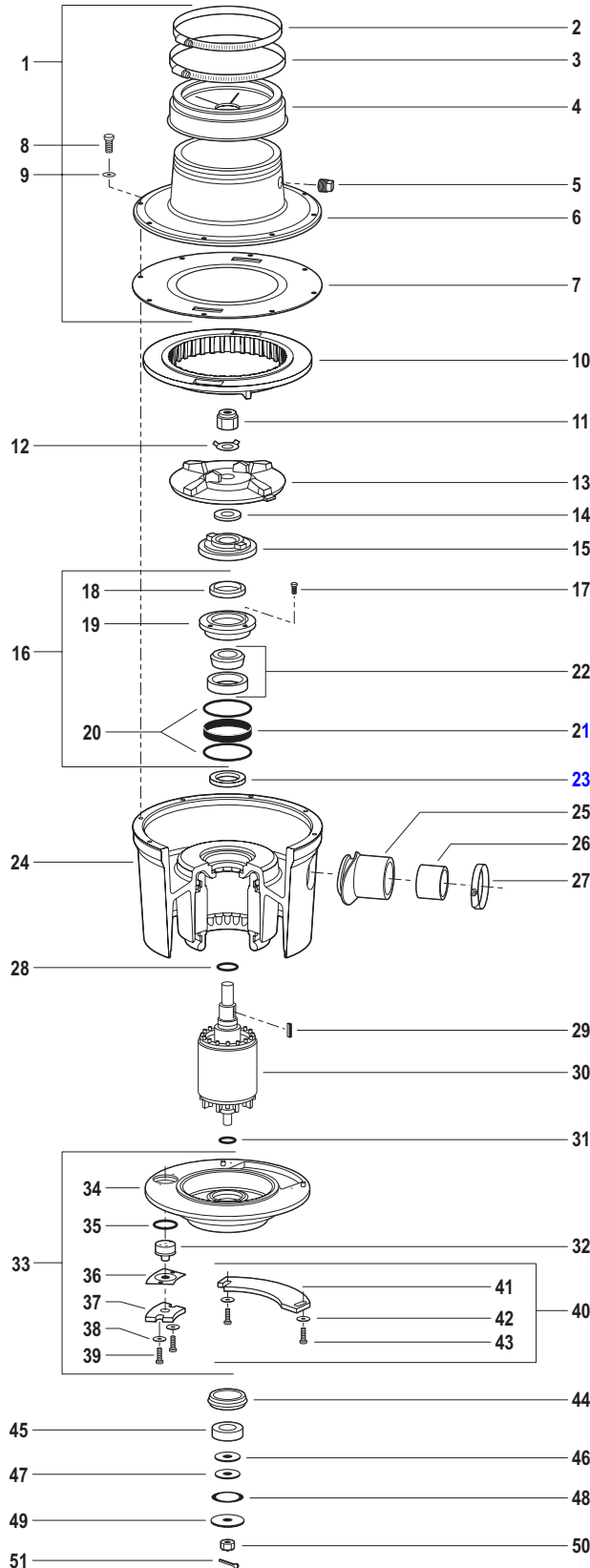

NO.	PART NO.	DESCRIPTION
1	980131	TOP HOUSING ASSY (includes 2 thru 7)
2	M116	CLAMP
3	M128	CLAMP
4	2357A	HYCAR ADAPTOR
5	PL5	PLUG 1/2" PLASTIC
6	983010	TOP HOUSING
7	996045	CENTER GASKET (S)(C)
8	997022	SCREW 5/16-18 X 1" HHCAP
9	997123	WASHER FLAT 11/32 x 5/8 OD SS
10	8SWX	SHREDDER (C)
11	7814RN	ROTOR NUT (S)(C)
12	997092	LOCK WASHER (S)(C)
13	983004	FACE PLATE (C)
14	996025	ROTOR SHAFT GASKET (S)(C)
15	980132	ROTOR BASE (S)(C)
16	980007	TOP END BELL ASSY (S) (includes 17 thru 21)
17	997066	SCREW 10-32 X 5/8" (S)
18	S67350B	VARILIP SEAL (S)
19	983001	TOP END BELL ASSY
20	12151	O-RING (S)
21	ANL79X15S	TOLERANCE RING (S)
22	985001	BEARING CUP/CONE TOP (S)
23	S67350	VARILIP SEAL (S)
24	MH2200725	HOUSING W/STATOR 2HP 208-230/460V 3-PH
25	RDO	DRAIN OUTLET 2"
26	DI	DRAIN INSERT 2"
27	M40	CLAMP DISPOSER 2"
28	11026	O-RING (S)
29	31634	KEY 3/16 x 3/16 x 3/4" (S)
30	99110825	MOTOR ROTOR 200-3
31	996020	O-RING (S)
32	KL2003	KLIXON
33	BEBA123G	BOTTOM END BELL ASSY (includes 34 thru 40)
34	983016	BOTTOM END BELL
35	123	KLIXON O-RING (S)
36	KLCG	KLIXON COVER GASKET
37	KLC	KLIXON COVER
38	997043	WASHER 10-32
39	997067	SCREW 10-32 X 3/4"
40	JBCA	JUNCTION BOX COVER ASSY (includes 41 thru 43)
41	JBC	JUNCTION BOX COVER
42	997024	WASHER 3/4" OD 3/16" ID
43	997067	SCREW 10-32 X 3/4"
44	996023	BEB RUBBER ISOLATOR (S)
45	6205	BOTTOM BEARING (S)
46	987002	DRIVE WASHER (S)
47	996024	FRICTION WASHER (S)
48	987003	WAVE WASHER (S)
49	987001	RETAINING WASHER (S)
50	997050	CASTLE NUT (S)
51	997051	COTTER PIN (S)

### SEAL AND CUTTING KITS

KSH123	Seal Kit (All Models)
KCJ2	Cutting Kit (Model 150-200)

(S) Designates Parts included in Seal Kit (C) Designates Parts included in Cutting Kit

SPECIFY VOLTAGE AND PHASE WHEN ORDERING

**SALVAJOR** 4530 East 75th Terrace  
FOOD WASTE SOLUTIONS Kansas City, MO 64132-2081 USA

CALL FREE: 1-888-SALVAJOR FAX FREE: 1-800-832-9373

Printed in USA  
Form No. PB/J-200-3 (1-26)