

# CU0415, CU0715 and CU0920 Service Parts

This is the illustrated parts list for the CU0415, CU0715 and CU0920. The CUR0415, CUR0715 and CUR0920 are -32 (208-230/60/1) versions of the matching models.

There are 3 voltages, 115/60/1, 208-230/60/1 and 230/50/1. Be sure of the voltage before selecting a part.

## Contents

Cabinet - CU0415 or CU0715 .....	2
Cabinet - CU0920.....	3
Under Bin Parts .....	4
Bin and Insulation .....	5
Refrigeration System - CU0415 and CU0715 .....	6
Refrigeration System - CU0920 .....	7
Water System .....	8
Controls and Electrical.....	9
Wiring Diagram.....	10
Schematic Diagram .....	11

# CU0415, CU0715 and CU0920 Service Parts

## Cabinet - CU0415 or CU0715

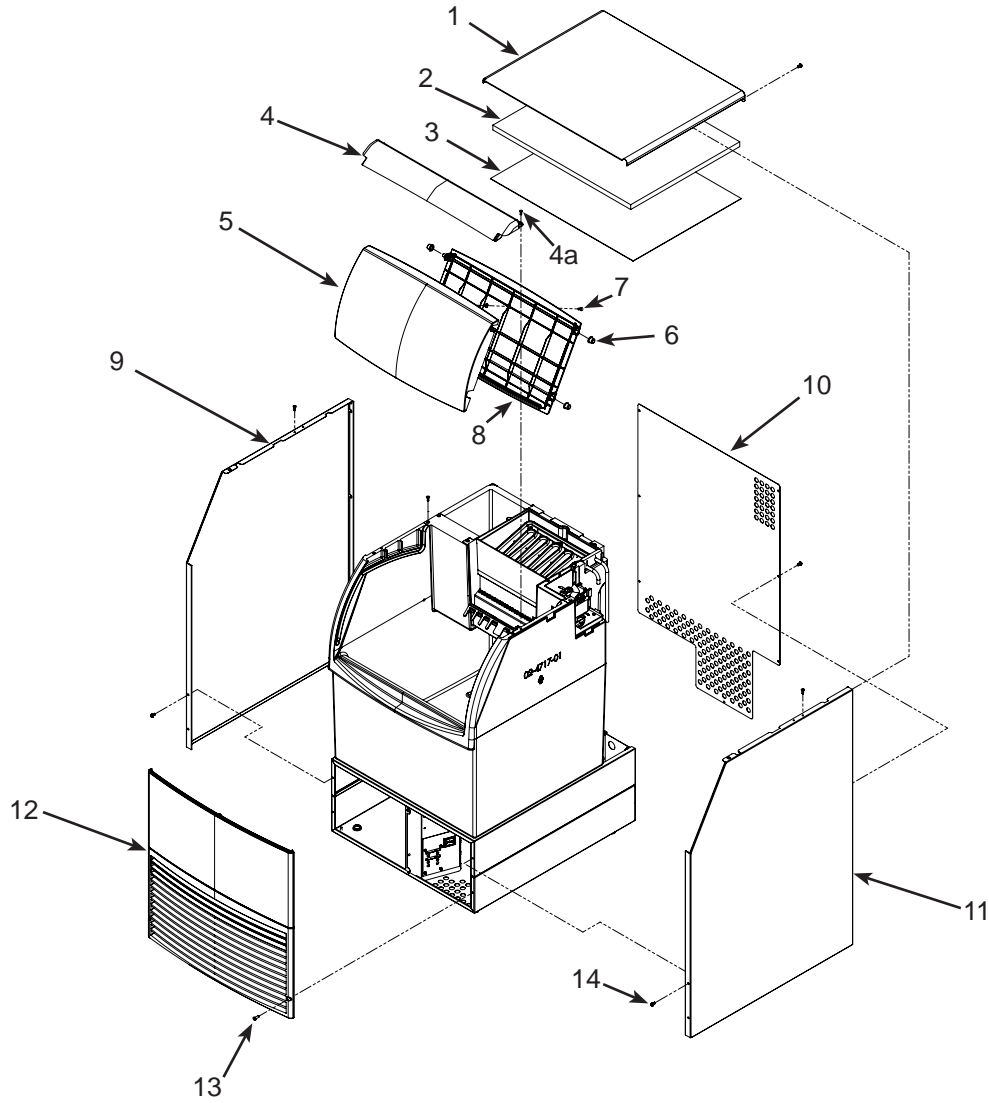

Item Number	Part Number	Description	Not illustrated
1	A39993-001	Top panel, 15 inch	15 KLP7 Leg kit
2	02-4677-01	Insulation, 15 inch	16 02-4391-03 Scoop
3	02-4694-01	Inner top panel, 15 inch	17 A40085-001 Bin thermostat tube, 15 inch
4	02-4691-01	Top frame, 15 inch	
4a	03-3836-04	Screw	
5	02-4685-01	Door, outer, 15 inch	
6	03-3941-01	Bushing	
	03-3940-01	Bumper (in door slot & base)	
7	03-3870-01	Screw	
8	02-4685-04	Door liner, 15 inch	
9	A39990-001	Left side panel	
10	A39996-001	Back panel, 15 inch	
11	A39990-002	Right side panel	
12	02-4683-01	Front panel, 15 inch	
13	03-1404-12	Screw	
14	03-3943-01	Screw	

# CU0415, CU0715 and CU0920 Service Parts

## Cabinet - CU0920

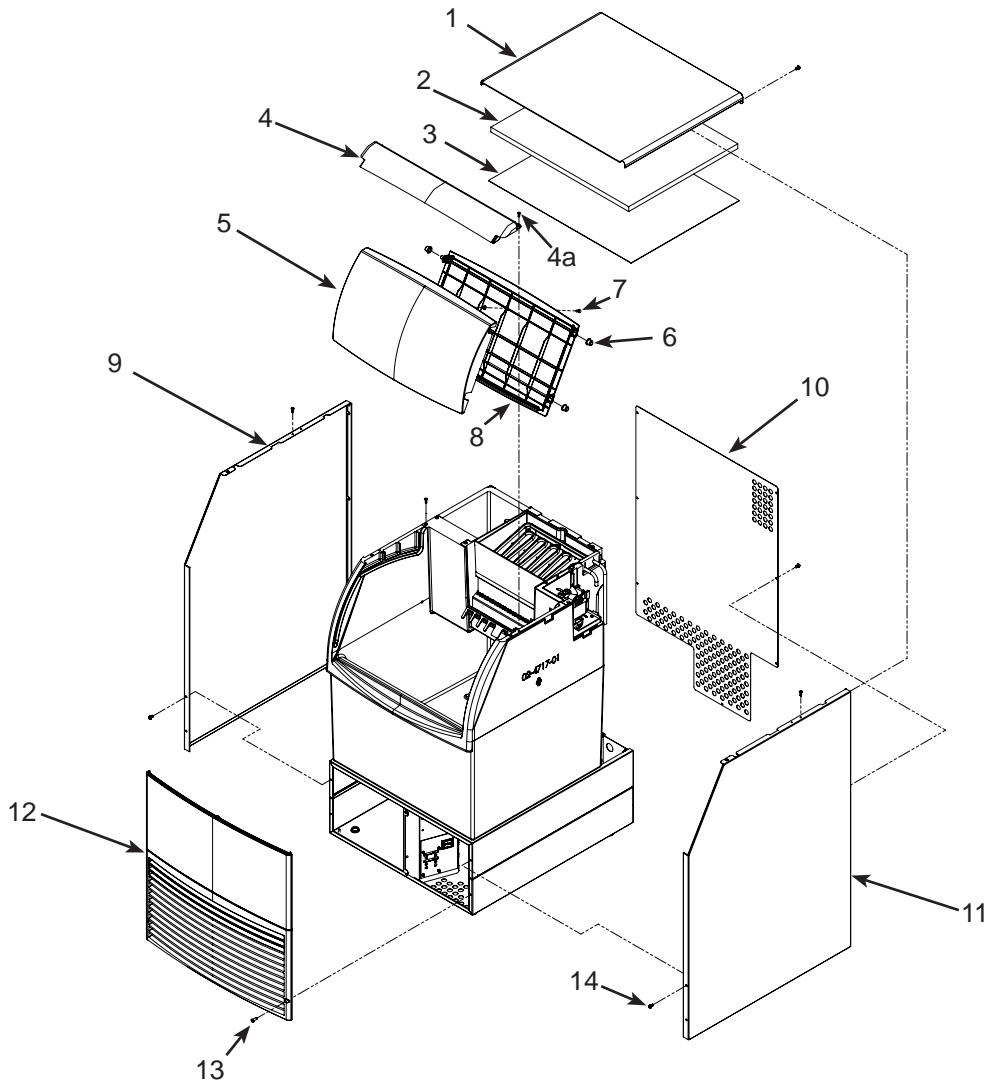

Item Number	Part Number	Description	Not illustrated
1	A39993-002	Top panel, 20 inch	15 KLP7 Leg kit
2	02-4677-02	Insulation, 20 inch	16 02-4391-03 Scoop
3	02-4695-01	Inner top panel, 20 inch	17 A40085-002 Bin thermostat tube, 20 inch
4	02-4692-01	Top frame, 20 inch	
4a	03-3836-04	Screw	
5	02-4686-01	Door, outer, 20 inch	
6	03-3941-01	Bushing	
	03-3940-01	Bumper (in door slot & base)	
7	03-3870-01	Screw	
8	02-4686-04	Door liner, 20 inch	
	02-4805-01	Rod, door support	
9	A39990-001	Left side panel	
10	A39997-001	Back panel, 20 inch	
11	A39990-002	Right side panel	
12	02-4684-01	Front panel, 20 inch	
13	03-1404-12	Screw	
14	03-3943-01	Screw	

# CU0415, CU0715 and CU0920 Service Parts

## Under Bin Parts

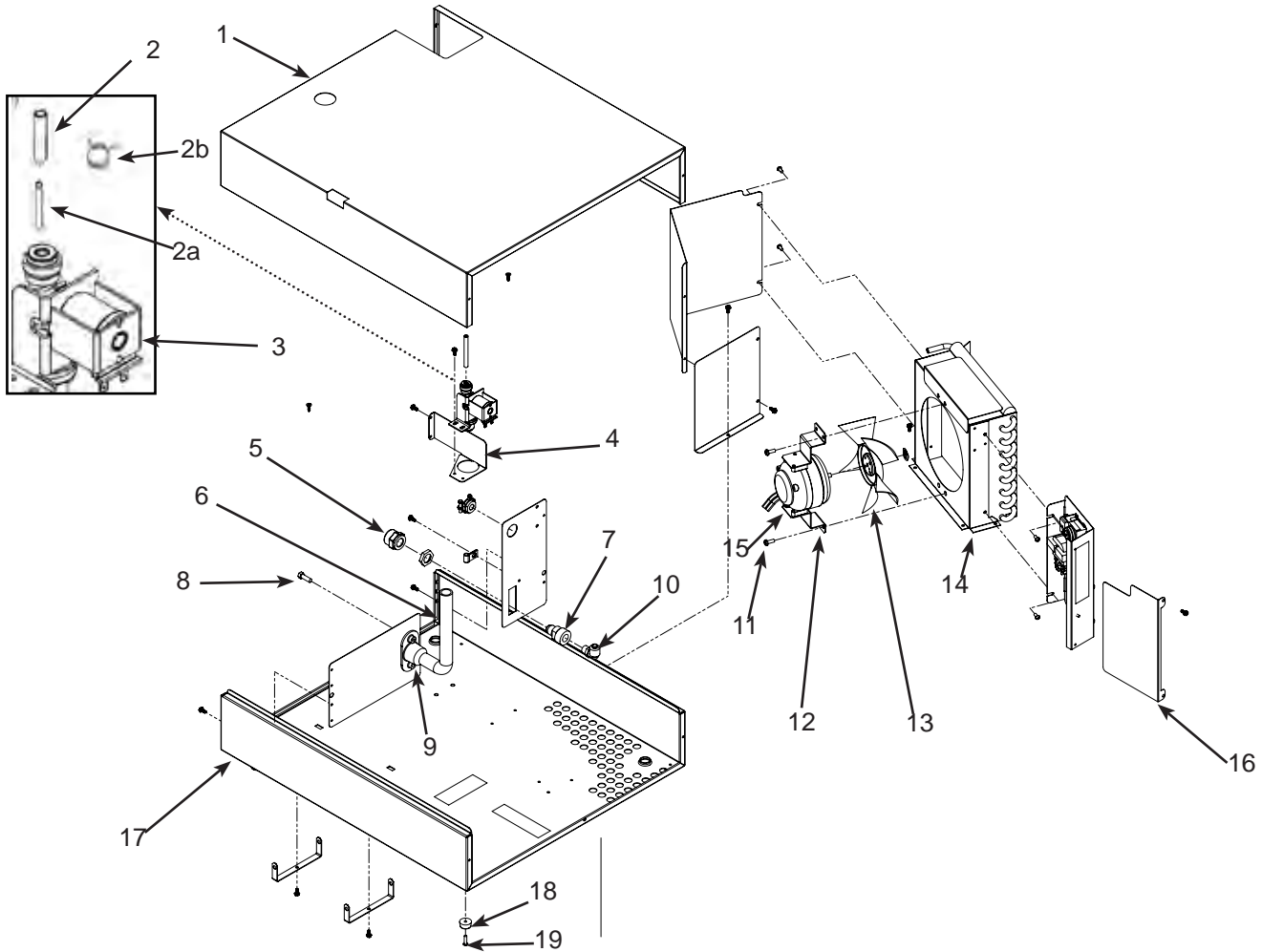

Item Number	Part Number	Description
1	A39991-001	Chassis cover, 15 inch
	A39991-002	Chassis cover, 20 inch
2	13-0674-01	1/4 ID Hose, requires < 24"
2a	13-0895-01	1/4 OD Hose, requires < 12"
2b	03-3961-01	Hose Clamp
3	12-3055-01	Inlet water sol valve, 115 volt
	12-3055-02	Inlet water sol valve, 230 volt
4	A40014-001	Bracket
5	16-1150-01	Adapter for 230 volt models
6	A39992-002	Drain hose
7	16-0835-01	Hose fitting, 230 volt models
8	03-0571-00	Screw for drain fitting
9	02-3692-23	Drain fitting kit
10	16-1081-01	Elbow, 230 volt models
11	03-3943-02	Screw
12	A39556-001	Fan motor bracket

13	02-4197-01	Fan blade
14	A39460-001	Fan shroud
15		Fan motor see table

Part number	Model Size	Voltage
12-3024-01	40	115
12-3024-01	70	115
12-2989-01	90	115
12-3024-03	40	230
12-3024-03	70	230
12-2989-02	90	230

16	A40077-001	Cover
17	A39994-001	Base, 15 inch
	A39995-001	Base, 20 inch
18	03-3940-01	Bumper
19	03-1531-08	Screw

# CU0415, CU0715 and CU0920 Service Parts

## Bin and Insulation

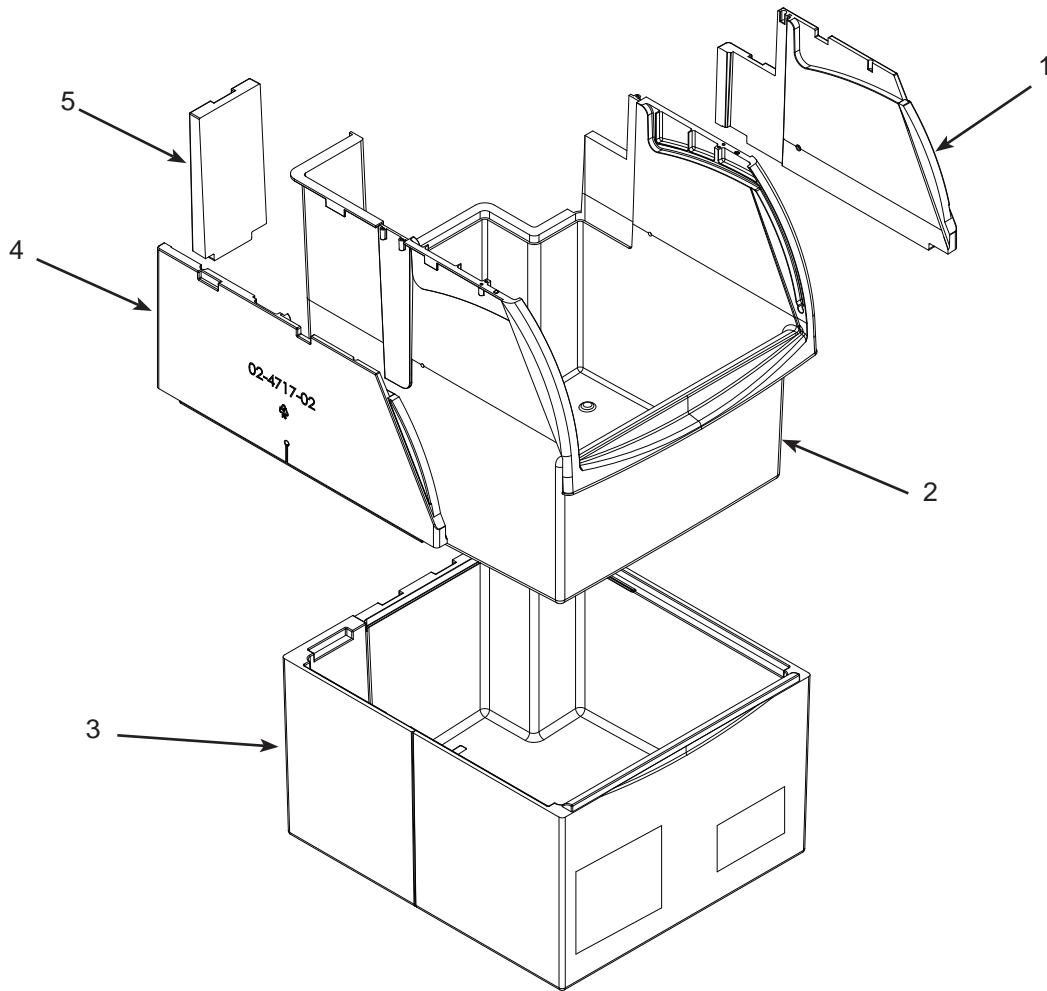

Item Number	Part Number	Description
1	02-4717-01	Right side insulation
2	02-4705-01	Bin liner, 15 inch
	02-4706-01	Bin liner, 20 inch
3	02-4696-01	Insulation, 15 inch bin
	02-4697-01	Insulation, 20 inch bin
4	02-4717-02	Left side insulation
5	02-4718-01	Insulation filler

# CU0415, CU0715 and CU0920 Service Parts

## Refrigeration System - CU0415 and CU0715

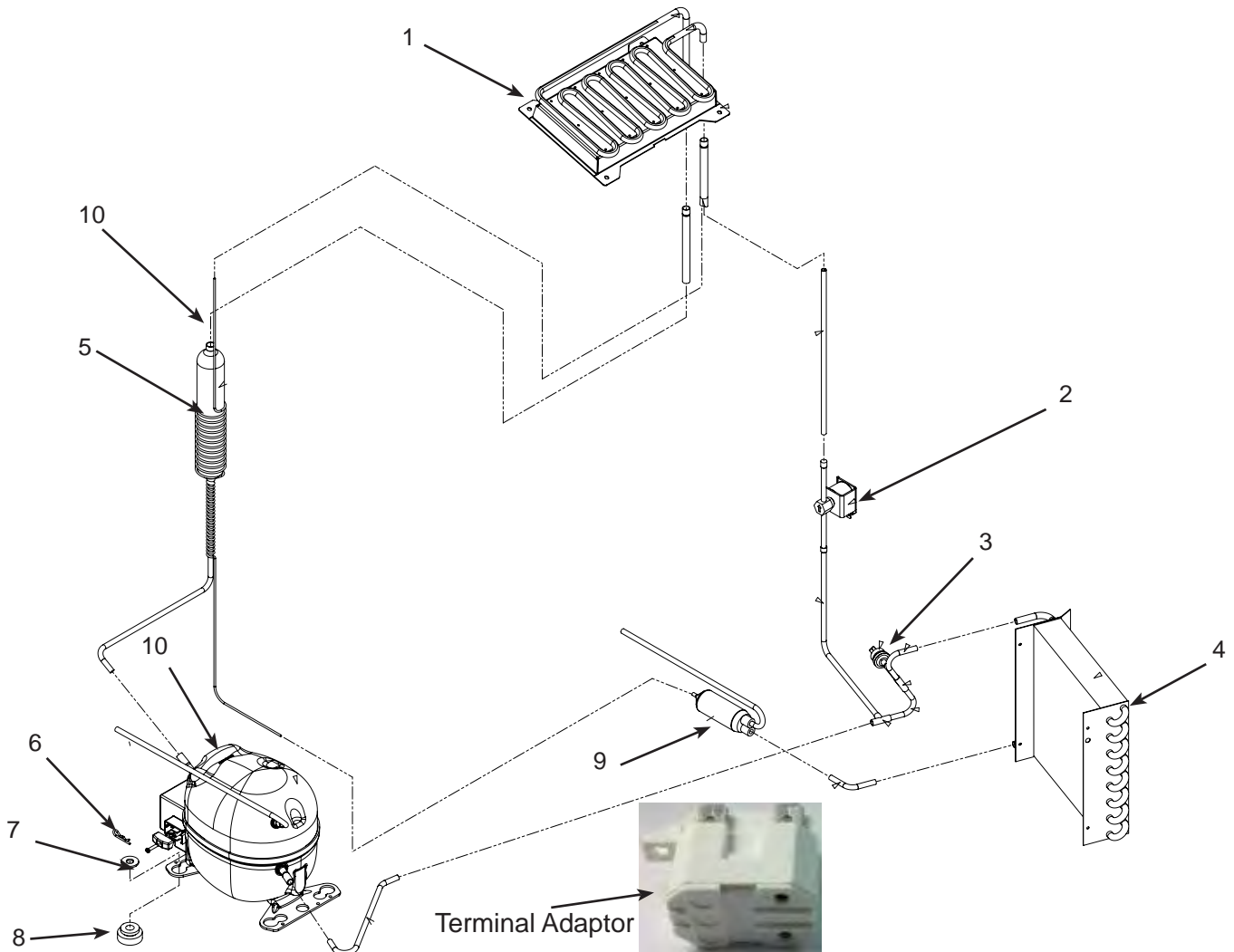

Item Number	Part Number	Description	Part Number	Description
1	A40204-021	Evaporator	5	A40009-001 Suction assy, 40 lb, 230 volt
2	11-0562-01	Hot gas valve, 115 volt		A40010-001 Suction assy, 40 lb 115 volt
	11-0562-02	Hot gas valve, 230 volt		A40010-001 Suction assy, 70 lb
3	11-0566-03	Fan motor pressure switch	6	03-3821-01 Clip
4	18-8940-01	Condenser	7	03-1407-08 Washer
			8	18-8964-01 Grommet
			9	02-4416-01 Dryer
			10	03-1711-01 Thermistor clip

### 11 Compressors and starting components

Model	Voltage	Compressor	Relay	Terminal Adaptor	Start Capacitor	Overload
CU0415-1	115/60/1	18-8962-21	18-8962-61	12-3008-01	18-8962-62	18-8962-63
CU0415-32 or -6	230/60-50	18-8962-22	18-8962-51	12-3008-01	18-8962-52	18-8962-53
CU0715-1	115/60/1	18-8956-21	18-8956-51	12-3008-01	18-8956-52	18-8956-53
CU0715-32 or -6	230/60-50	18-8960-22	18-8960-51	12-3008-01	18-8960-52	18-8960-53

Compressors include starting components and a dryer.

# CU0415, CU0715 and CU0920 Service Parts

## Refrigeration System - CU0920

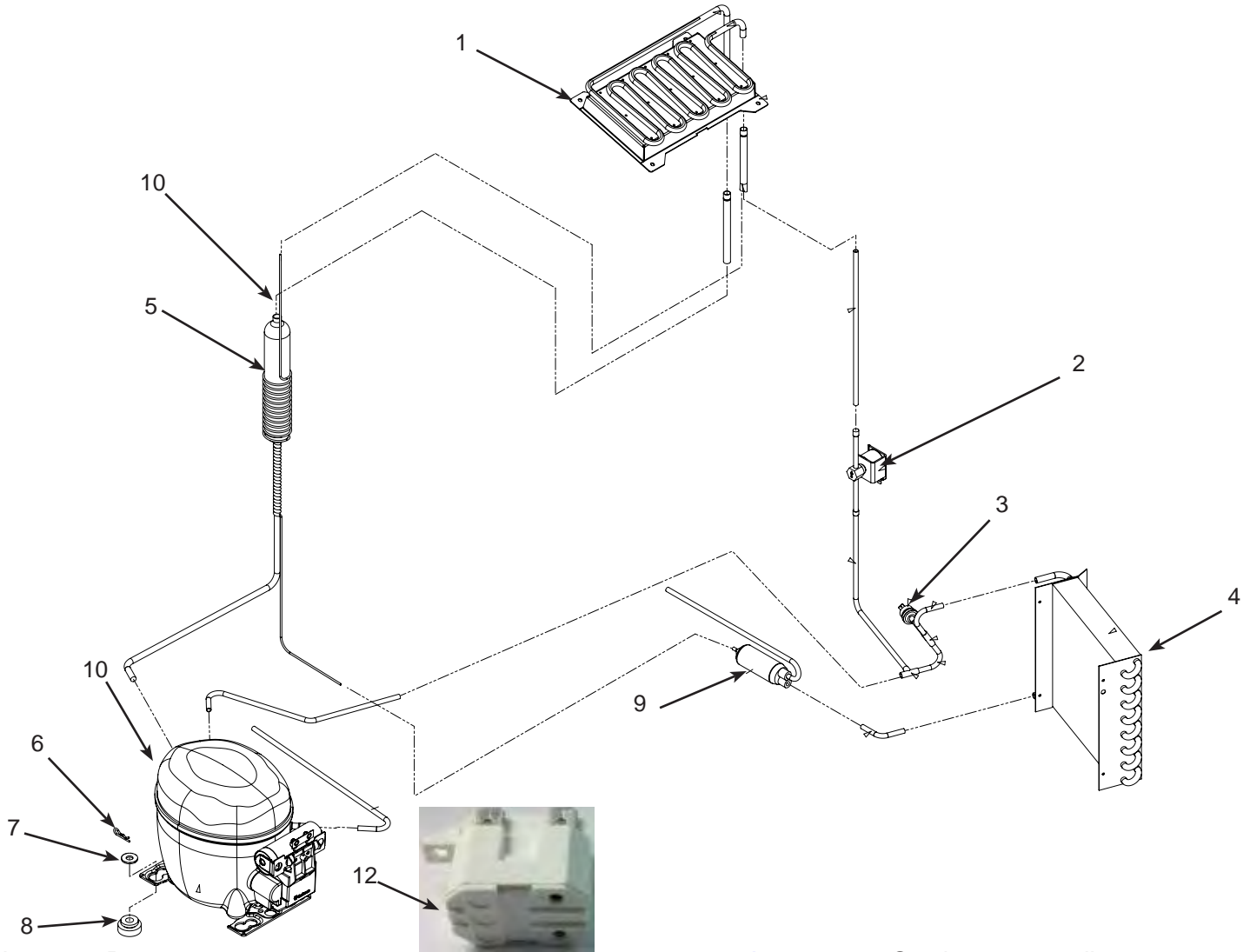

Item Number	Part Number	Description
1	<a href="#">A40204-021</a>	Evaporator
2	<a href="#">11-0562-01</a>	Hot gas valve, 115 volt
	<a href="#">11-0562-02</a>	Hot gas valve, 230 volt
3	<a href="#">11-0566-03</a>	Fan motor pressure switch
4	<a href="#">18-8940-01</a>	Condenser
5	<a href="#">A40011-001</a>	Suction assy, 90 lb
6	<a href="#">03-3821-01</a>	Clip
7	<a href="#">03-1407-08</a>	Washer
8	<a href="#">18-8964-01</a>	Grommet
9	<a href="#">02-4416-01</a>	Dryer
10	<a href="#">03-1711-01</a>	Thermistor clip
12	<a href="#">12-3008-01</a>	Terminal Adaptor

### 11 Compressors and starting components

Model	Voltage	Compressor	Relay	Terminal Adaptor	Start Capacitor	Overload
CU0920-1	115/60	<a href="#">18-8959-21</a>	<a href="#">18-8959-51</a>	<a href="#">12-3008-01</a>	<a href="#">18-8959-52</a>	<a href="#">18-8959-53</a>
CU0920-32	230/60	<a href="#">18-8959-22</a>	<a href="#">18-8959-54</a>	<a href="#">12-3008-01</a>	<a href="#">18-8959-55</a>	<a href="#">18-8959-56</a>
CU0920-6	230/50	<a href="#">18-8957-26</a>	<a href="#">18-8957-51</a>	<a href="#">12-3008-01</a>	<a href="#">18-8957-52</a>	<a href="#">18-8957-53</a>

Compressors include starting components and a dryer.

# CU0415, CU0715 and CU0920 Service Parts

## Water System

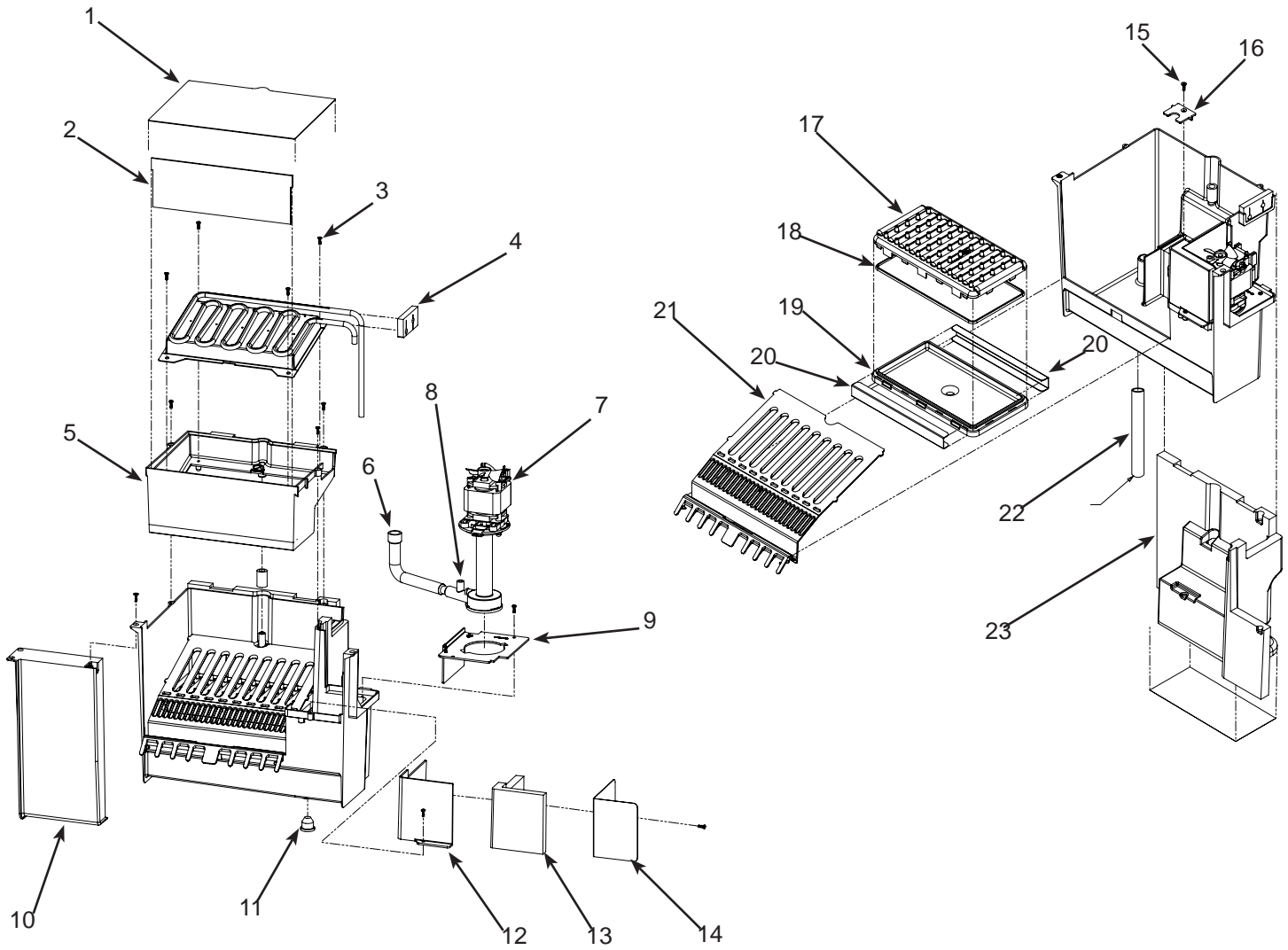

Item Number	Part Number	Description
1	02-4688-01	Evaporator cover
2	02-4707-01	Curtain
3	03-3836-04	Screw
4	02-4704-01	Grommet
5	02-4679-01	Evap frame
6	02-4678-01	Pump hose, 60 Hz models
	02-4739-01	Pump hose, 50 Hz models
7	12-2986-21	Water pump, 115 volt models
	12-2986-22	Water pump, 230 volt models
8	11-0606-01	Thermistor, long/blue wire to pump hose
9	02-4703-01	Pump bracket
10	02-4699-01	Support
11	13-0840-01	Drain plug
12	02-4702-01	Pump cover
13	02-4690-01	Insulation
14	A40003-001	Motor barrier
15	03-3870-01	Screw
16	02-4904-01	Clip
17	02-4680-01	Water header top
18	02-4693-01	Gasket
19	02-4681-01	Water header pan
20	A40012-001	Water header clip
21	02-4689-01	Cube deflector
22	13-0674-07	Hose, 11.25" req.
23	02-4687-01	Insulation

# CU0415, CU0715 and CU0920 Service Parts

## Controls and Electrical

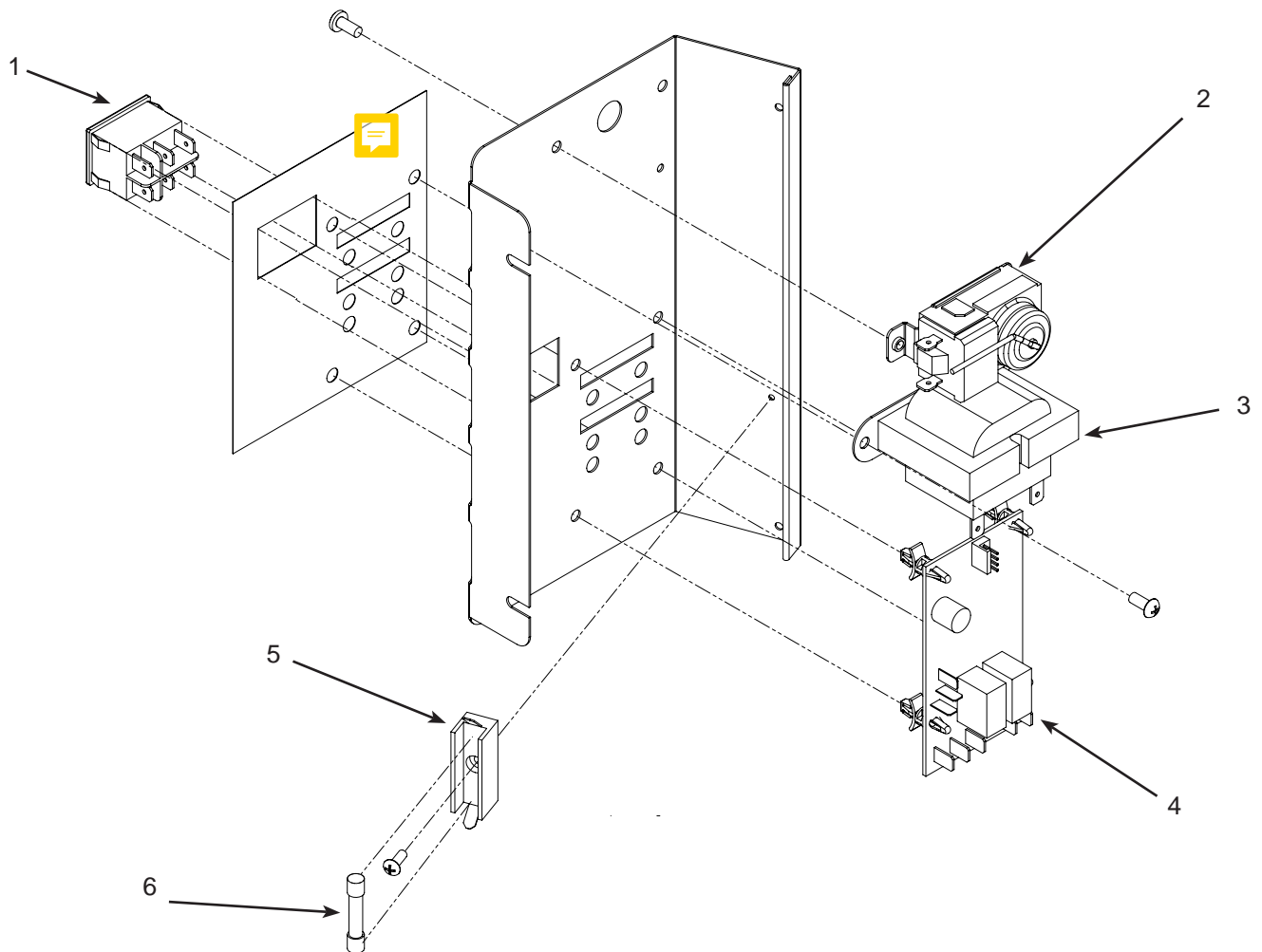

Item Number	Part Number	Description
1	12-3062-01	Master switch
2	11-0617-21	Bin thermostat
3	12-2924-01	Transformer 115 to 12
	12-2924-03	Transformer 230 to 12
4	11-0599-21	Controller
5	12-2687-01	Fuse block, 50 Hz only
6	12-2686-01	Fuse, 50 Hz only
Not shown		
7	12-3056-01	Wire harness, fits all
8	12-1638-14	Power cord, 115 volt models
	12-1638-22	Power cord, 230 volt, 50 Hz
	12-1638-23	Power cord, 230 volt, 60 Hz

# CU0415, CU0715 and CU0920 Service Parts

## Wiring Diagram

17-3439-01

REV. A

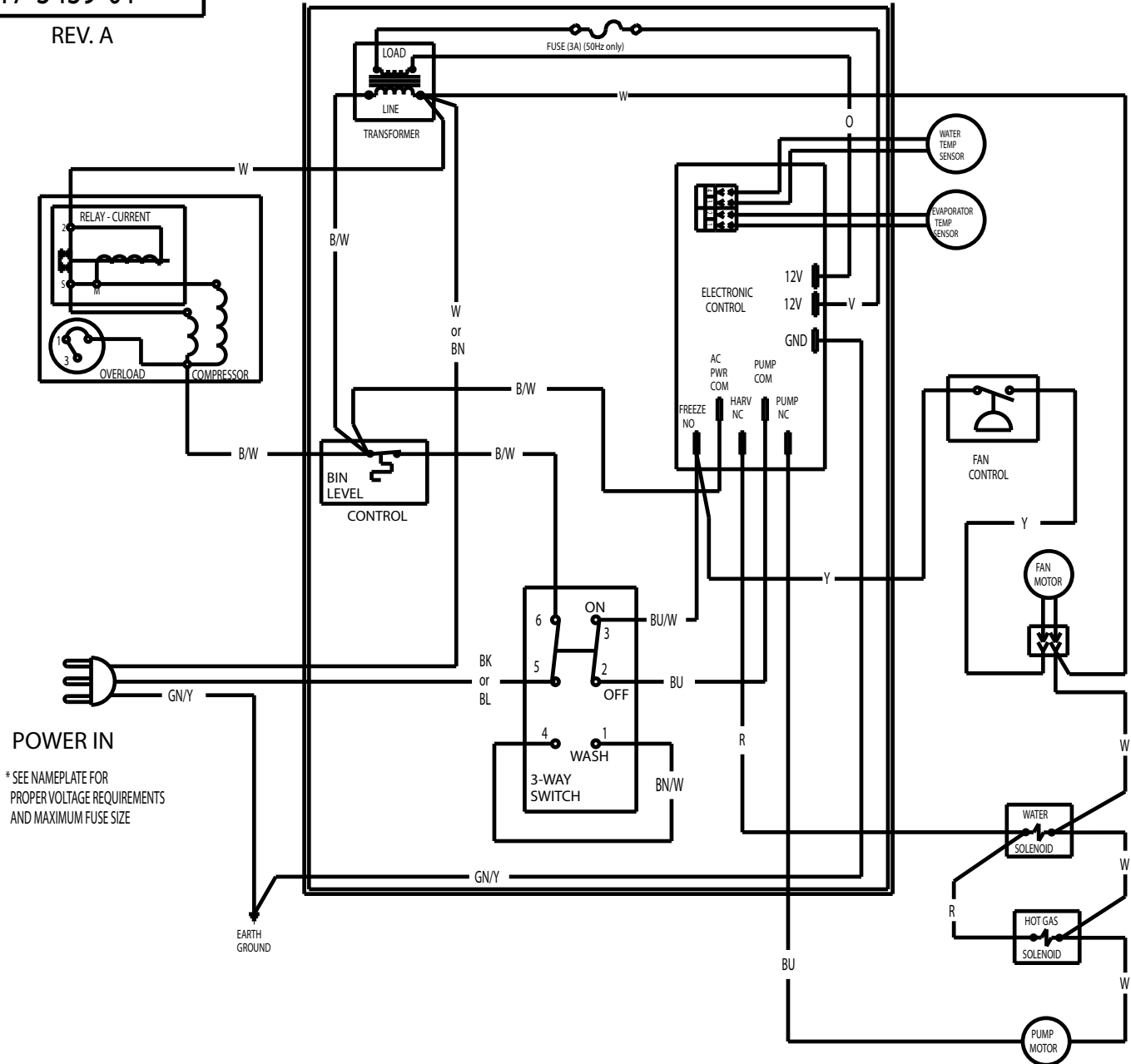

POWER IN  
\* SEE NAMEPLATE FOR PROPER VOLTAGE REQUIREMENTS AND MAXIMUM FUSE SIZE

**CAUTION:**  
MORE THAN ONE DISCONNECT MEANS MAY BE REQUIRED TO DISCONNECT ALL POWER TO UNIT

THIS UNIT MUST BE GROUNDED

# CU0415, CU0715 and CU0920 Service Parts

## Schematic Diagram

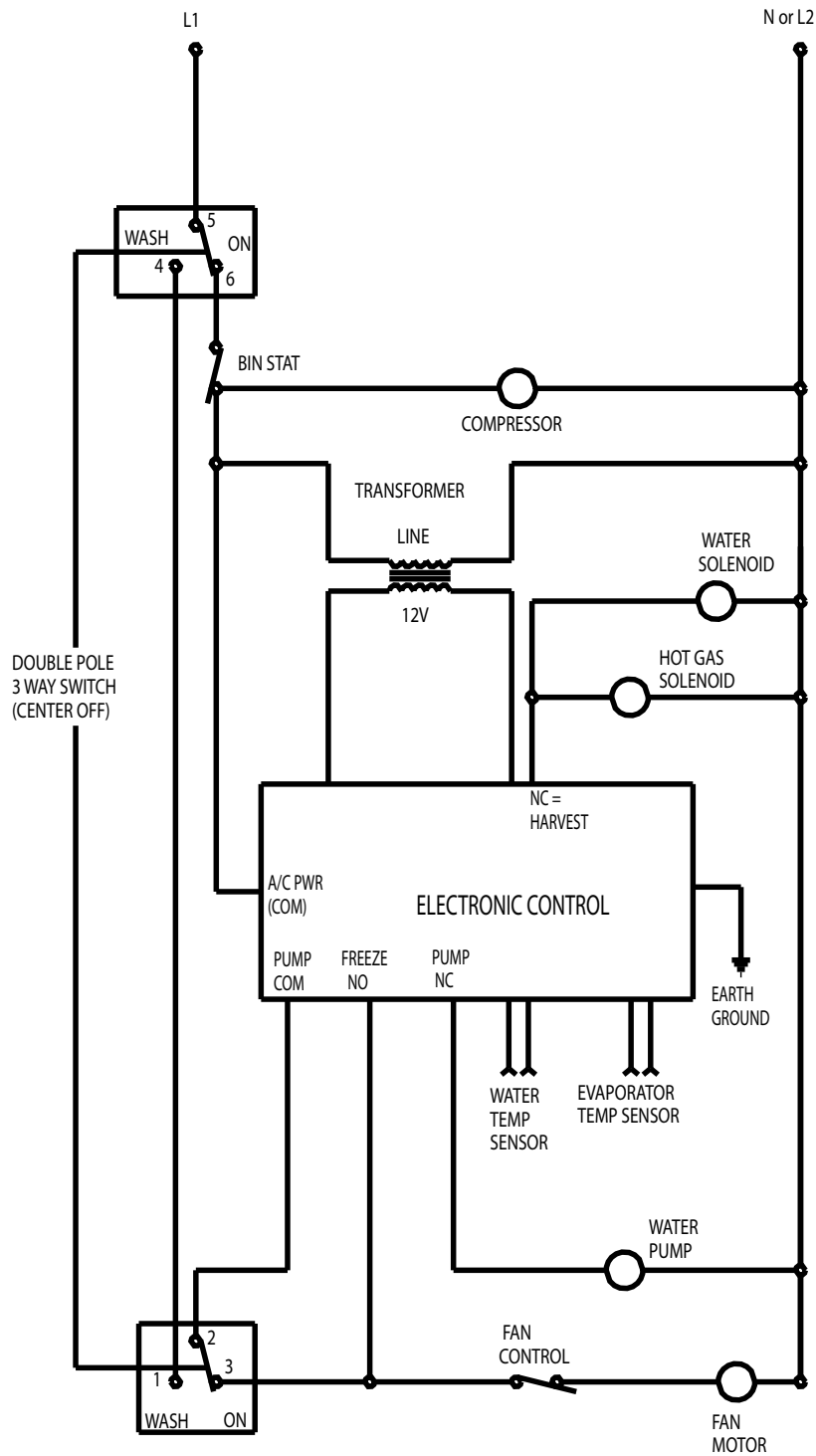

SWITCHES ON THIS UNIT  
SHOWN IN FREEZE CYCLE