

SCN60 Service Parts

This is the illustrated parts list for the SCN60.
There are two models, one is a gravity drain and the other includes a drain pump. Some units could have had drain pumps field installed.

Contents

Door Components	2
Cabinet	3
Storage Bin and Ice Chute	4
Reservoir, Water Sensor and Misc.	5
Refrigeration	6
Under Bin Parts	7
Ice Making Section	8
Control System	9
Wiring Diagram	10
Schematic Diagram	11

SCN60 Service Parts

Ice Making Section

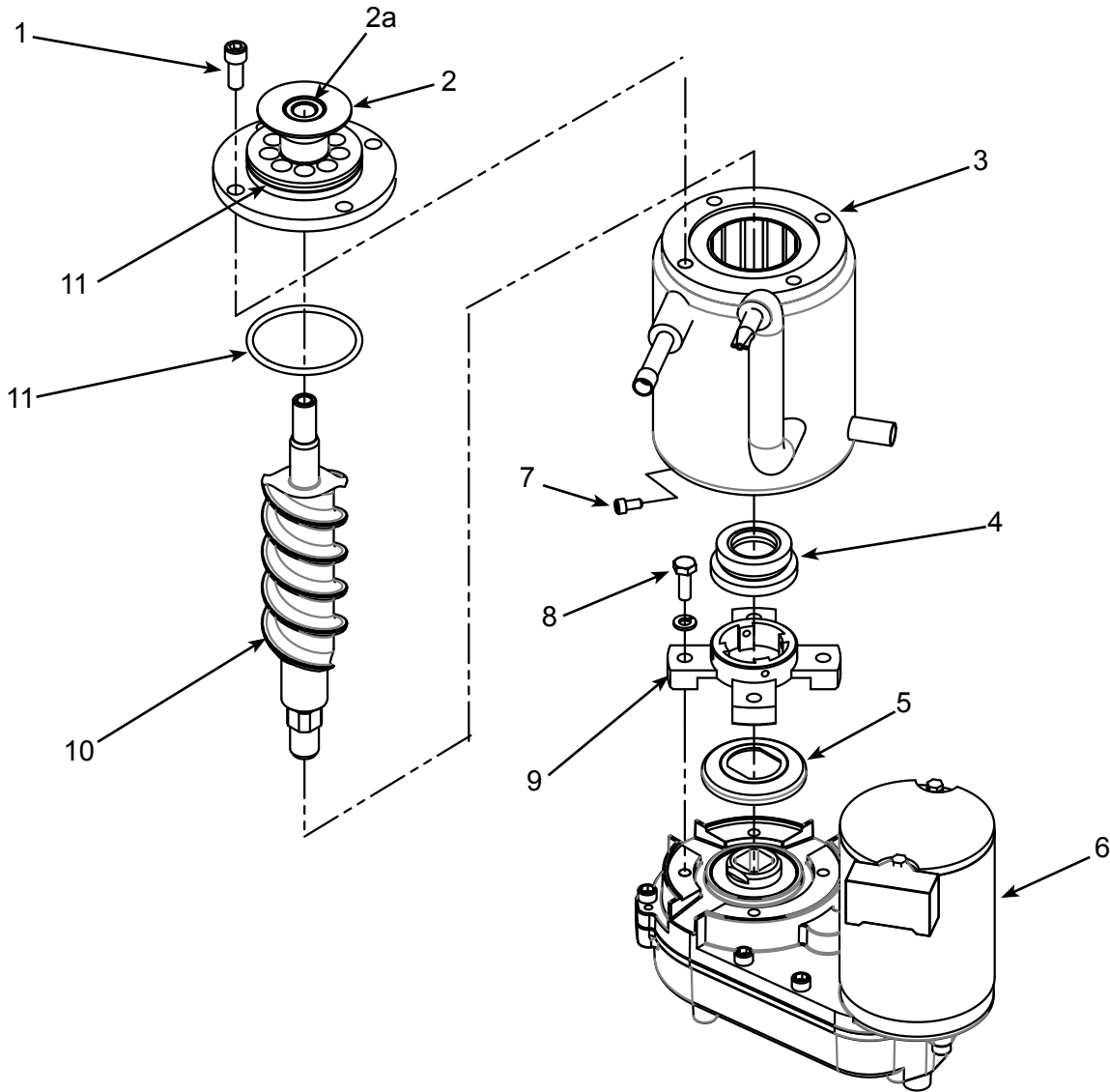

Item Number	Part Number	Description
1	03-1544-08	Cap screw
2	A39531-001	Breaker w/bearing
2a	02-4619-01	Bearing only
3	02-4558-01	Evaporator
4	02-4599-21	Water seal
5	02-4662-01	Water shed
6	02-4580-23	Gear reducer and motor also includes #5
7	03-1544-04	Cap screw
8	03-1405-54	Cap screw
9	02-4625-01	Adapter
10	02-4591-21	Auger
11	13-0617-58	O-ring

* Must connect wires correctly. See label on motor.

SCN60 Service Parts

Control System

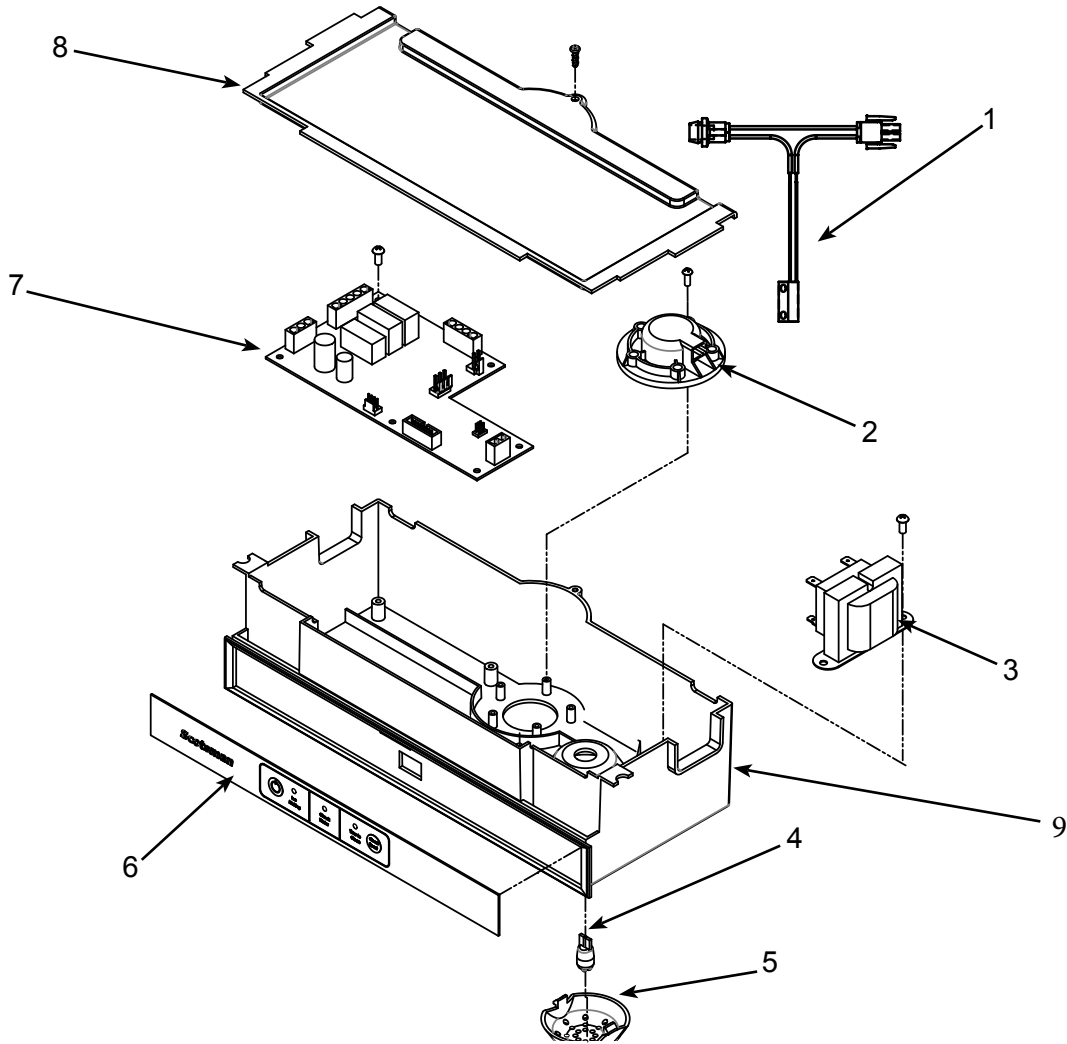

Item Number	Part Number	Description
1	12-3076-01	Light switch, bulb socket and harness
2	11-0579-01	Ice level sensor
3	12-2924-01	Transformer
4	12-3077-01	Bulb
5	02-4380-01	Light cover
6	11-0574-01	Control panel
7	11-0589-21	Controller
8	02-4386-01	Cover
9	02-4382-03	Box only

Not Shown

NS1 12-1638-21 Power cord

SCN60 Service Parts

Wiring Diagram

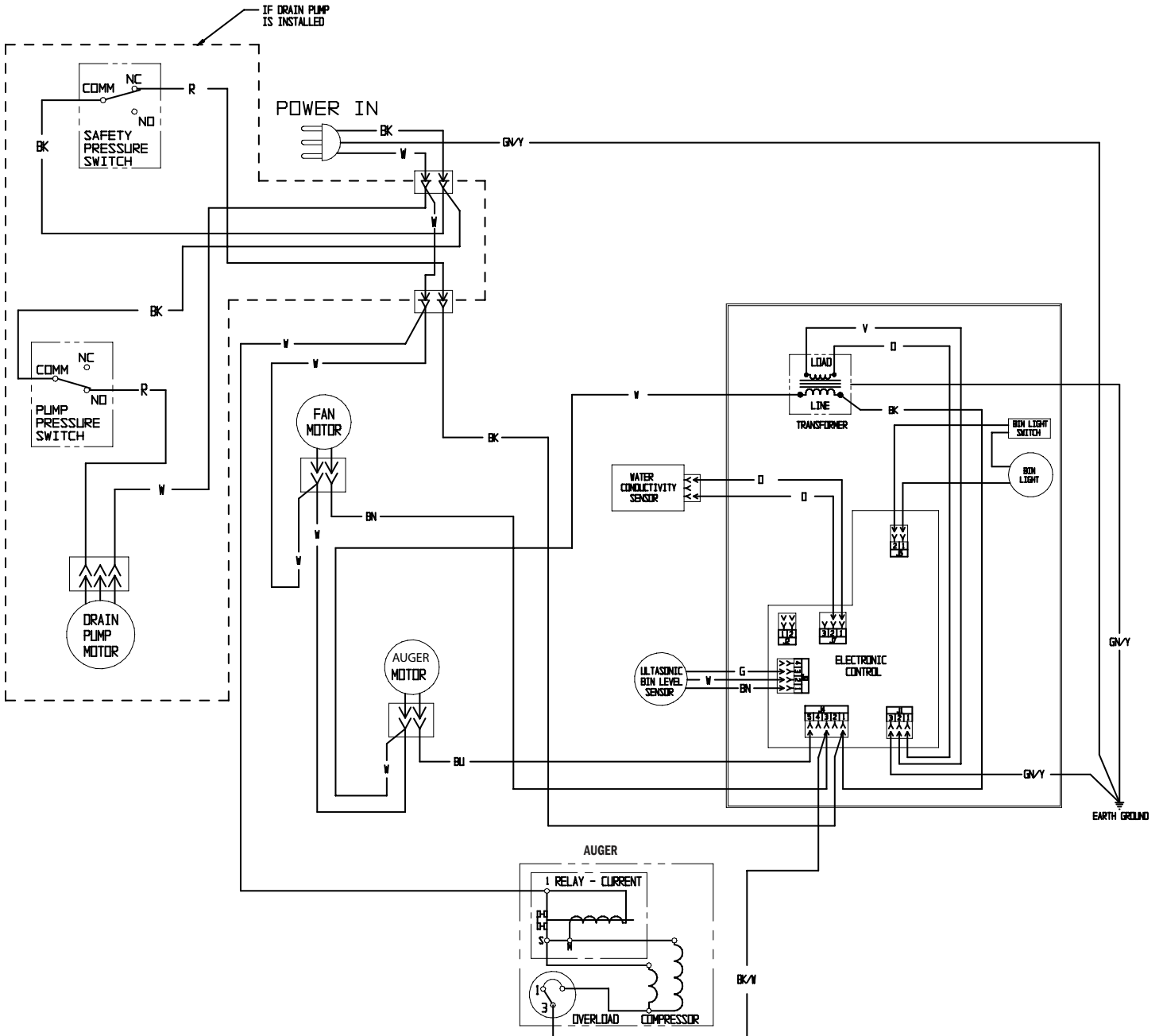

SCN60 Service Parts

Schematic Diagram

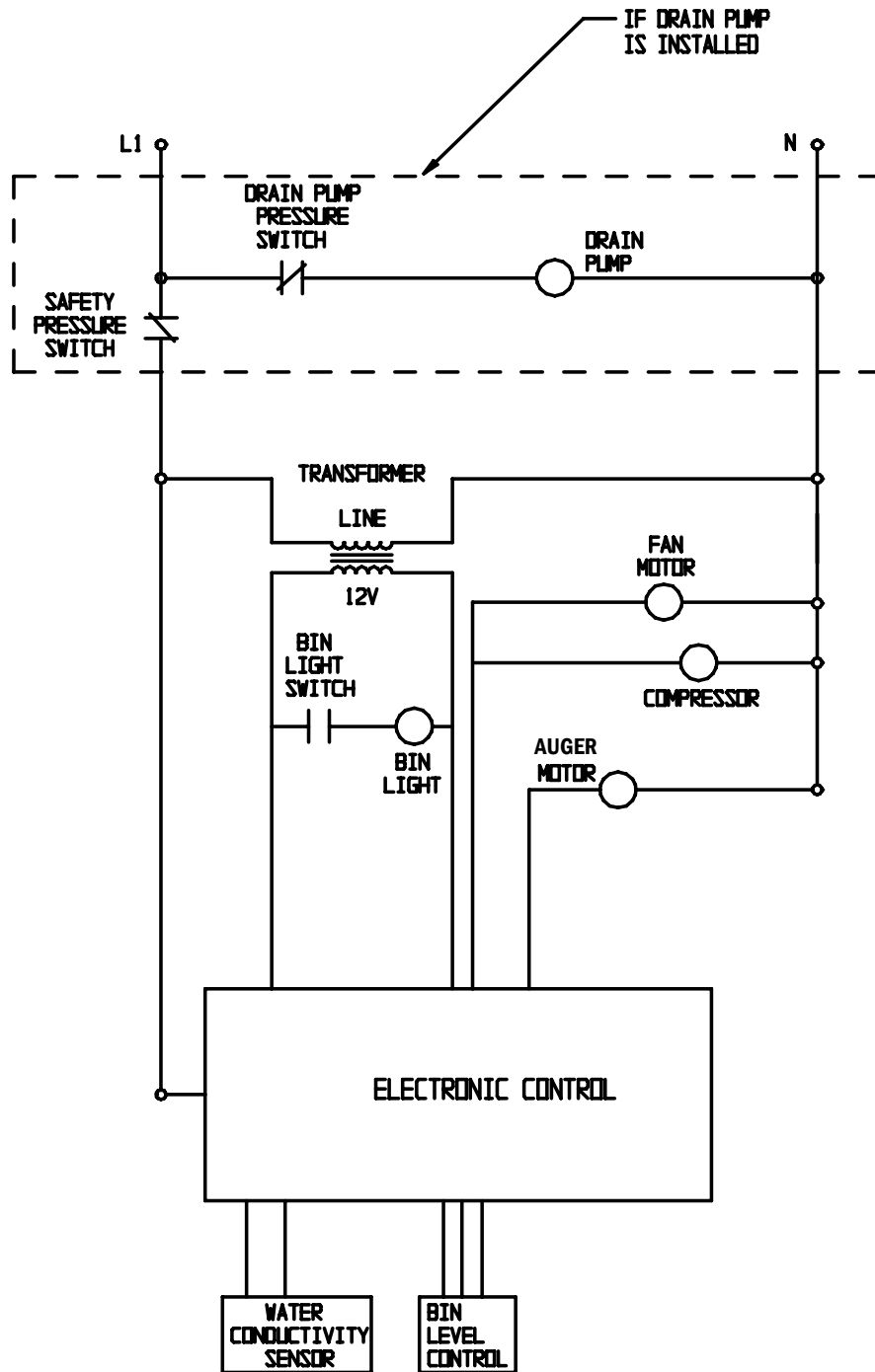

SWITCHES ON THIS UNIT
SHOWN IN FREEZE CYCLE
WITH DRAIN PUMP IN OPERATION
AND BIN DOOR CLOSED