

## SmartVide 8 Users Manual

### MODELS

This manual describes the installation, operation and maintenance of the SmartVide 8 sous-vide cooker. The model reference and its characteristics appear on the name plate attached to the machine.

These appliances have been designed and manufactured in accordance with the following standards:

**European directives and standard** (versions at 230V 50/60Hz)

Machine Directive: 2006/42/EC

Low Voltage Directive 2006/95/EC

Electromagnetic Compatibility Directive: 2004/108/EC

Protection level in accordance with standard UNE-EN 60529: IP-X1

### Standards applicable in America

(Versions at 120V 60Hz and 208-240V 50/60Hz)

Safety standards for machines UL 197, CSA C22.2 109 Edition  
Hygiene and materials standards NSF/ANSI Standard 4

### START-UP AND INSTALLATION

For optimum performance and long-lasting preservation of your machine, carefully follow the start-up and installation instructions given in this manual and the intended conditions of use.

#### Location

Use this appliance in a ventilated kitchen at an ambient temperature no higher than 40°C.

Do not block nor obstruct the ventilation slits.

Do not place the appliance next to or near sources of heat.

#### Electric connection

Before plugging the appliance in, make sure that the mains voltage coincides with the voltage indicated on the name plate attached to the machine.

**CAUTION: THE EARTH CONNECTION IS OBLIGATORY.  
DANGER OF ELECTROCUTION.**

#### Start-up

**Preparing the container:** Place a suitable container on a flat, level, rigid, non-combustible surface, preferably near a sink or drain for emptying. When the working temperature of the water exceeds 60°C it is very important to use a lid, to avoid excess steam. Thus you will prevent heat loss and protect the appliance from moisture. See Fig. B

**Securing the device:** Hold the appliance firmly and secure it with sufficient stability to the container. Ensure that the switch and socket are within your reach while using the appliance. See Fig. B

**Filling the container with water:** This appliance is designed only for sous-vide cooking at a low temperature with water. We recommend using decalcified soft water. Take into account the maximum and minimum fill levels for the water. See Fig. B  
Never start up the device without water. The appliance has a float guard to detect the minimum water level. Always check that the float guard is working before using the unit. Check this

manually by taking the machine out of the container vertically, for example.

**Start-up:** Connect the appliance and switch it on using the switch at the rear and set the desired temperature. After heating the water to the desired temperature, place the vacuum packed food in the cooking bath. Parts of the bath and lid can get very hot during use. Take great care when touching them! Use cloths or oven gloves!

Use the timer function to programme the desired time. Once the programmed time has been reached an alarm will sound. Press any button to stop the alarm and remove the food from the bath.

#### Cleaning

The water in the container must be changed daily and the appliance cleaned periodically.

To avoid electric shocks that can cause serious personal injury, switch the appliance off and unplug it before cleaning.

- Never let water get inside the appliance.
- Never clean the appliance under running water or submerge it in water.
- Do not use: abrasive cleaning products such as ammonia, bleach, etc. solvents, metal scourers, gritty detergent.
- Clean the immersion parts of the appliance with soapy water and a cloth or sponge and dry with soft cloth. Use your hand to check that the float moves, without forcing it. Use a dry cloth to clean the parts that are not immersed.
- You can clean the protective grille periodically in the dishwasher.

#### Maintenance

Before every use, check that the low level float is working properly.

#### Other important remarks

- If the power supply is damaged and a new one must be installed, only a Sammic authorised technical service can replace it.
- This appliance is not to be used by people (including children of 8 years and over) with limited physical, sensorial or mental capabilities, or that lack the experience or knowledge, unless they have been supervised or instructed in the use of appliance by a person responsible for their safety and understand the dangers it entails. Do not allow children to play with the appliance.
- The cleaning and maintenance to be performed by the user must not be performed by unsupervised children.
- Only people qualified in sous-vide cooking may cook using this method. It is vitally important to follow procedures that minimise the risk of formation of anaerobic bacteria.
- This machine is for supervised use. Never leave the machine running unsupervised.

## Working with the SmartVide 8



### Working with the needle probe



Connect the needle probe to the machine.



SET set temperature of the needle probe at which we want it to warn us. Press PLAY to save the data.



Peep, Peep...!!! It has reached the temperature. Indicates the time passed. Press any button to view stop the beeper sound. Press END to finish the cycle.

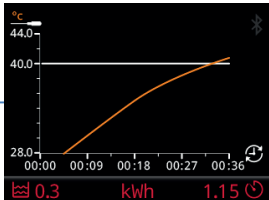

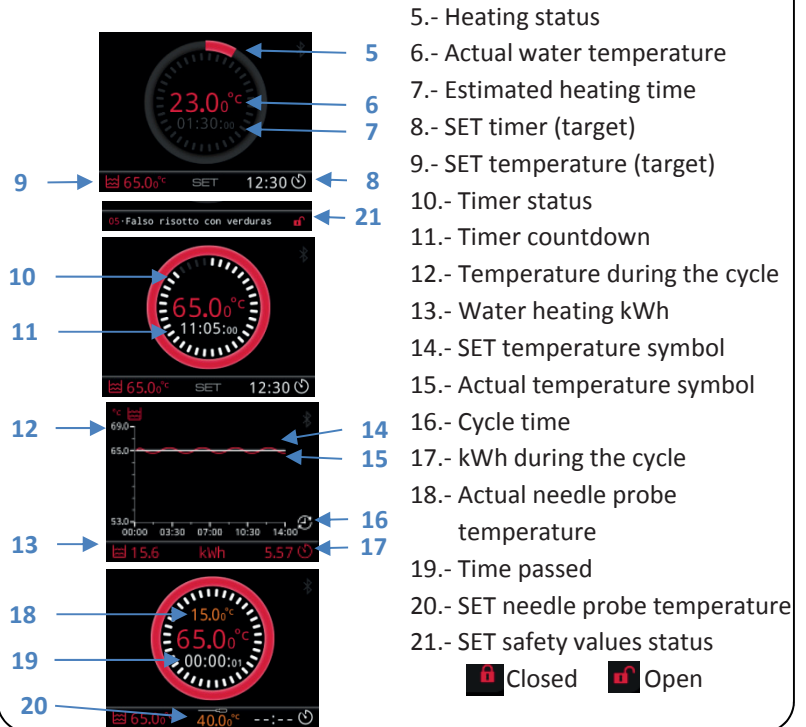

End! SUMMARY of the cycle. Press any button for a new cycle.

### Characteristics



- 5.- Heating status
- 6.- Actual water temperature
- 7.- Estimated heating time
- 8.- SET timer (target)
- 9.- SET temperature (target)
- 10.- Timer status
- 11.- Timer countdown
- 12.- Temperature during the cycle
- 13.- Water heating kWh
- 14.- SET temperature symbol
- 15.- Actual temperature symbol
- 16.- Cycle time
- 17.- kWh during the cycle
- 18.- Actual needle probe temperature
- 19.- Time passed
- 20.- SET needle probe temperature
- 21.- SET safety values status

 Closed 
  Open

### Fault warning

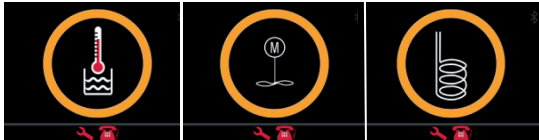

Temperature sensor water

Stirrer motor

Heating element

Note: Call a Technical Service

### Warning



Lack of water. Fill.

Power cut during the cycle. Indicates time and temperature before and after the power cut

Overheating cab

### Change °C/°F

- 1.- Machine off.
- 2.- Holding down the SET button, switch on the machine.
- 3.- Change the unit.

### Calibration

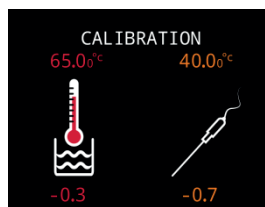

- 1.- Machine off
- 2.- Holding down the – and + buttons, switch on the machine.
- 3.- CALIBRATION screen
- 4.- Adjust the value with SET and the – and + buttons
- 5.- Turn off and on again.

Fig. A

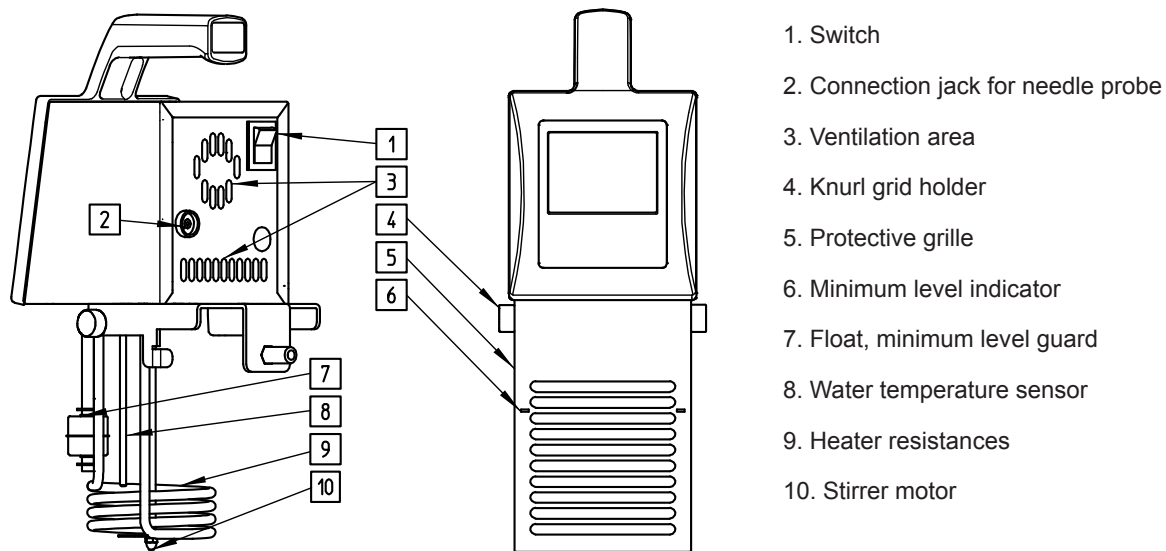
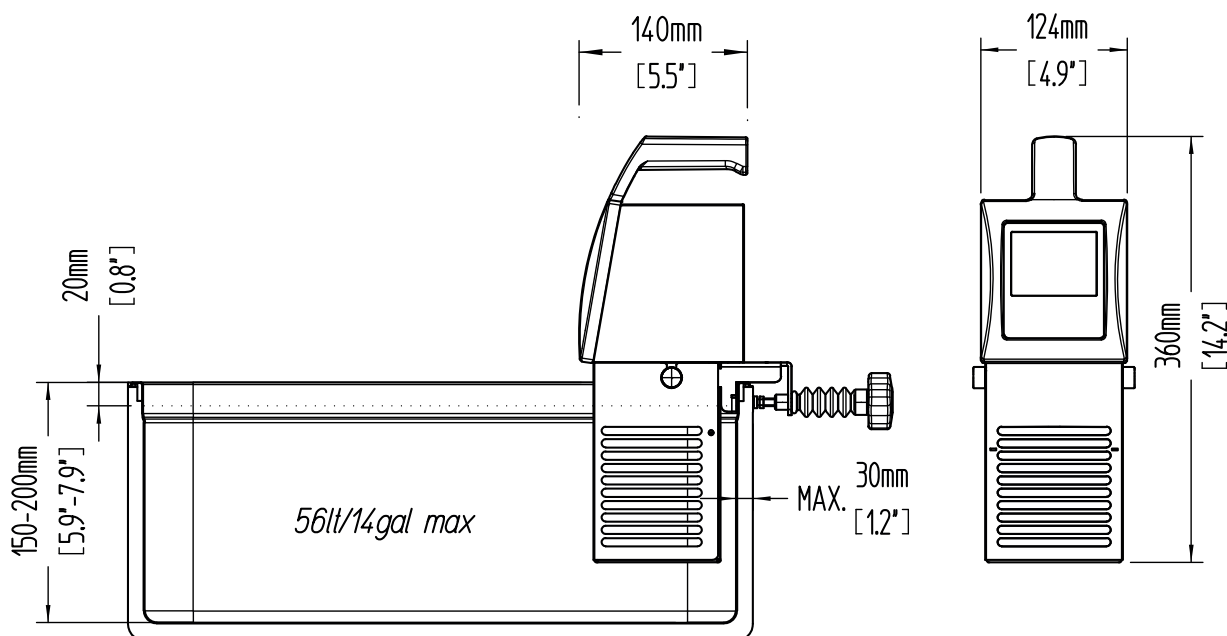

Fig. B



SPECIFICATIONS	SMARTVIDE 8		
Working temperature	5°C to 95°C / 41°F to 203°F		
Resolution display	0.01°C / 0.1°F		
Time resolution	1 min		
Cycle duration	1 min 99 h		
Display	3.5" colour TFT		
Permitted ambient temperature	5°C to 40°C / 41°F to 104°F		
Maximum capacity	56 l / 14 gal		
Power supply	120V/60Hz/1	208-240V/50-60Hz/1	230V/50-60Hz/1
Power consumption	11A	9A	9A
Power	1,400W	2,000W	2,000W
Dimensions (Width x Depth x Height)	124mm x 140mm x 360mm / 4.9" x 5.5" x 14.2"		
Net weight	4.1kg / 9lb.		



UNE-EN ISO 9001