

STR-DH550/DH750

SERVICE MANUAL

Ver. 1.0 2014.01



Photo: STR-DH750

US Model
Canadian Model
AEP Model
UK Model
Australian Model
STR-DH550/DH750
Brazilian Model
Mexican Model
Taiwan Model
STR-DH750

This receiver incorporates Dolby® Digital and Pro Logic Surround and the DTS** Digital Surround System.

* Manufactured under license from Dolby Laboratories. Dolby, Pro Logic, Surround EX, and the double-D symbol are trademarks of Dolby Laboratories.

** For DTS patents, see <http://patents.dts.com>. Manufactured under license from DTS Licensing Limited. DTS, DTS-HD, the Symbol, & DTS and the Symbol together are registered trademarks, and DTS-HD Master Audio is a trademark of DTS, Inc. © DTS, Inc. All Rights Reserved.

This receiver incorporates High-Definition Multimedia Interface (HDMI™) technology. The terms HDMI and HDMI High-Definition Multimedia Interface, and the HDMI Logo are trademarks or registered trademarks of HDMI Licensing LLC in the United States and other countries.

iPhone, iPod, iPod classic, iPod nano, and iPod touch are trademarks of Apple Inc., registered in the U.S. and other countries. App Store is a service mark of Apple Inc.

All other trademarks and registered trademarks are of their respective holders. In this manual, ™ and ® marks are not specified.

“Made for iPod” and “Made for iPhone” mean that an electronic accessory has been designed to connect specifically to iPod or iPhone, respectively, and has been certified by the developer to meet Apple performance standards. Apple is not responsible for the operation of this device or its compliance with safety and regulatory standards. Please note that the use of this accessory with iPod or iPhone may affect wireless performance.

Windows Media is either a registered trademark or trademark of Microsoft Corporation in the United States and/or other countries.

This product is protected by certain intellectual property rights of Microsoft Corporation. Use or distribution of such technology outside of this product is prohibited without a license from Microsoft or an authorized Microsoft subsidiary.

MPEG Layer-3 audio coding technology and patents licensed from Fraunhofer IIS and Thomson.

“x.v.Color (x.v.Colour)” and “x.v.Color (x.v.Colour)” logo are trademarks of Sony Corporation.

“BRAVIA” is a trademark of Sony Corporation.

“PlayStation” is a registered trademark of Sony Computer Entertainment Inc.

“WALKMAN” and “WALKMAN” logo are registered trademarks of Sony Corporation.

MICROVAULT is a trademark of Sony Corporation.

MHL, Mobile High-Definition Link and the MHL Logo are trademarks or registered trademarks of MHL Licensing, LLC.

The Bluetooth® word mark and logos are registered trademarks owned by Bluetooth SIG, Inc. and any use of such marks by Sony Corporation is under license.

Other trademarks and trade names are those of their respective owners.

© 2013 CSR plc and its group companies. The aptX® mark and the aptX logo are trade marks of CSR plc or one of its group companies and may be registered in one or more jurisdictions.

The N Mark is a trademark or registered trademark of NFC Forum, Inc. in the United States and in other countries.

Android™ is a trademark of Google Inc.

Google Play™ is a trademark of Google Inc.

SPECIFICATIONS

AUDIO POWER SPECIFICATIONS

POWER OUTPUT AND TOTAL HARMONIC DISTORTION: (USA model only)

With 6 ohm loads, both channels driven, from 20 – 20,000 Hz, rated 90 watts per channel minimum RMS power, with no more than 0.09% total harmonic distortion from 250 milliwatts to rated output.

Amplifier section

Mexico model

Minimum RMS Output Power¹⁾
(6 ohms, 20 Hz – 20 kHz, THD 0.09%)
90 W + 90 W

Stereo Mode Output Power¹⁾
(6 ohms, 1 kHz, THD 1%)
100 W + 100 W

Surround Mode Output Power¹⁾²⁾
(6 ohms, 1 kHz, THD 0.9%)
140 W per channel

Other models

Minimum RMS Output Power¹⁾
(6 ohms, 20 Hz – 20 kHz, THD 0.09%)
90 W + 90 W

Stereo Mode Output Power¹⁾
(6 ohms, 1 kHz, THD 1%)
105 W + 105 W

Surround Mode Output Power¹⁾²⁾
(6 ohms, 1 kHz, THD 0.9%)
145 W per channel

¹⁾ Measured under the following conditions:

Area	Power requirements
US, CND, TW	120 V AC, 60 Hz
MX	127 V AC, 60 Hz
AUS, AEP, UK	230 V AC, 50 Hz
BR	220 V AC, 60 Hz

²⁾ Reference power output for front, center, surround, surround back and front high speakers. Depending on the sound field settings and the source, there may be no sound output.

Frequency response

Analog
10 Hz – 100 kHz, +0.5/–2 dB (with sound field and equalizer bypassed)

Input

Analog
Sensitivity: 500 mV/50 kilohms
S/N³⁾: 105 dB (A, 500 mV⁴⁾)
Digital (Coaxial)
Impedance: 75 ohms
S/N: 100 dB (A, 20 kHz LPF)
Digital (Optical)
S/N: 100 dB (A, 20 kHz LPF)

Output (Analog)
SUBWOOFER
Voltage: 2 V/1 kilohm

Equalizer

Gain levels
±10 dB, 1 dB step

³⁾ INPUT SHORT (with sound field and equalizer bypassed).

⁴⁾ Weighted network, input level.

FM tuner section

Tuning range
87.5 MHz – 108.0 MHz
Antenna (aerial)

FM wire antenna (aerial)
Antenna (aerial) terminals
75 ohms, unbalanced

AM tuner section

Tuning range

Area	Tuning scale	
	10 kHz step	9 kHz step
US, CND, MX, BR	530 kHz – 1,710 kHz	531 kHz – 1,710 kHz
AUS, AEP, UK, TW	–	531 kHz – 1,602 kHz

Antenna (aerial)
Loop antenna (aerial)

Video section

Inputs/Outputs
Video:
1 Vp-p, 75 ohms

– Continued on next page –

MULTI CHANNEL AV RECEIVER

9-890-636-01

2014A80-1

© 2014.01

Sony Corporation

Published by Sony EMCS (Malaysia) PG Tec

SONY®

STR-DH550/DH750

HDMI Video

Input/Output (HDMI Repeater block)

Format	2D	3D		
		Frame packing	Side-by-Side (Half)	Over-Under (Top-and-Bottom)
4096 × 2160p @ 59.94/60 Hz	○ ¹⁾	–	–	–
4096 × 2160p @ 50 Hz	○ ¹⁾	–	–	–
3840 × 2160p @ 59.94/60 Hz	○ ¹⁾	–	–	–
3840 × 2160p @ 50 Hz	○ ¹⁾	–	–	–
4096 × 2160p @ 23.98/24 Hz	○ ²⁾	–	–	–
3840 × 2160p @ 29.97/30 Hz	○ ²⁾	–	–	–
3840 × 2160p @ 25 Hz	○ ²⁾	–	–	–
3840 × 2160p @ 23.98/24 Hz	○ ²⁾	–	–	–
1920 × 1080p @ 59.94/60 Hz	○	–	○	○
1920 × 1080p @ 50 Hz	○	–	○	○
1920 × 1080p @ 29.97/30 Hz	○ ³⁾	○	○ ³⁾	○ ³⁾
1920 × 1080p @ 25 Hz	○ ³⁾	○	○ ³⁾	○ ³⁾
1920 × 1080p @ 23.98/24 Hz	○ ³⁾	○	○ ³⁾	○ ³⁾
1920 × 1080i @ 59.94/60 Hz	○ ³⁾	○	○ ³⁾	○ ³⁾
1920 × 1080i @ 50 Hz	○ ³⁾	○	○ ³⁾	○ ³⁾
1280 × 720p @ 59.94/60 Hz	○ ³⁾	○	○ ³⁾	○ ³⁾
1280 × 720p @ 50 Hz	○ ³⁾	○	○ ³⁾	○ ³⁾
1280 × 720p @ 29.97/30 Hz	○ ³⁾	○	○ ³⁾	○ ³⁾
1280 × 720p @ 23.98/24 Hz	○ ³⁾	○	○ ³⁾	○ ³⁾
720 × 480p @ 59.94/60 Hz	○ ³⁾	–	–	–
720 × 576p @ 50 Hz	○ ³⁾	–	–	–
640 × 480p @ 59.94/60 Hz	○ ³⁾	–	–	–

¹⁾ Supports YUV 4:2:0 / 8 bit format only.

²⁾ Supports 8 bit format only.

³⁾ These formats are also supported by an MHL connection.

MHL section

Supported MHL version
Incorporates MHL 2
Maximum current
900 mA

iPhone/iPod section

DC 5V 1.0 A MAX

USB works with iPhone 5s, iPhone 5c, iPhone 5, iPhone 4s, iPhone 4, iPhone 3GS, iPhone 3G, iPod touch (2nd through 5th generation), iPod classic, and iPod nano (3rd through 7th generation).

Bluetooth technology works with iPhone 5s, iPhone 5c, iPhone 5, iPhone 4s, iPhone 4, iPhone 3GS, and iPod touch (4th and 5th generation).

You can use "SongPal" app with this receiver via Bluetooth.

USB section

Supported format*

MP3 (MPEG 1 Audio Layer-3):

32 kbps – 320 kbps, VBR

WMA:

48 kbps – 192 kbps

AAC:

48 kbps – 320 kbps

WAV:

8 kHz – 48 kHz, 16 bit PCM

* Compatibility with all encoding/writing software, recording devices and recording media cannot be guaranteed.

Transfer speed

Full-speed

Supported USB device

Mass Storage Class

Maximum current

500 mA

Bluetooth section

Communication system

Bluetooth Specification version 3.0

Output

Bluetooth Specification Power Class 2

Maximum communication range

Line of sight approx. 10 m (33 feet)¹⁾

Frequency band

2.4 GHz band (2.4000 GHz – 2.4835 GHz)

Modulation method

FHSS (Freq Hopping Spread Spectrum)

Compatible Bluetooth profiles²⁾

A2DP (Advanced Audio Distribution Profile)

AVRCP 1.3 (Audio Video Remote Control Profile)

Supported Codecs³⁾

SBC⁴⁾, AAC, aptX

Transmission range (A2DP)

20 Hz – 20,000 Hz (Sampling frequency 44.1 kHz)

¹⁾ The actual range will vary depending on factors such as obstacles between devices, magnetic fields around a microwave oven, static electricity, cordless phone, reception sensitivity, antenna's performance, operating system, software application, etc.

²⁾ Bluetooth standard profiles indicate the purpose of Bluetooth communication between devices.

³⁾ Codec: Audio signal compression and conversion format

⁴⁾ Subband Codec

General

Power requirements

Area	Power requirements
US, CND, TW	120 V AC, 60 Hz
MX	127 V AC, 60 Hz
AUS	230 V AC, 50 Hz
AEP, UK	230 V AC, 50/60 Hz
BR	127/220 V AC, 60 Hz

Power consumption

240 W (Except DH550 : AEP, UK, US, CND, AUS)

200 W (DH550 : AEP, UK, US, CND, AUS)

Power consumption (during standby mode)

0.3 W (When "Control for HDMI", "Pass Through" and "Bluetooth Standby" are set to "Off".)

0.5 W (When "Control for HDMI" is set to "On", "Pass Through" and "Bluetooth Standby" are set to "Off".)

Dimensions (width/height/depth) (Approx.)

430 mm × 156 mm × 329.4 mm

(17 in × 6 1/4 in × 13 in) including projecting parts and controls

Mass (Approx.)

7.6 kg (16 lb 13 oz)

Design and specifications are subject to change without notice.

Supplied accessories

- Quick Setup Guide (1)
- Reference Guide (1)
- Remote control (RM-AAU190) (1)
- R6 (size AAA) batteries (2)
- FM wire antenna (aerial) (1)



- AM loop antenna (aerial) (1)



- Optimizer microphone (ECM-AC2) (1)



Design and specifications are subject to change without notice.

• Halogenated flame retardants are not used in the certain printed wiring boards.

Abbreviation

AUS : Australian model

BR : Brazilian model

CND : Canadian model

MX : Mexican model

TW : Taiwan model

SAFETY CHECK-OUT

After correcting the original service problem, perform the following safety check before releasing the set to the customer:

Check the antenna terminals, metal trim, “metallized” knobs, screws, and all other exposed metal parts for AC leakage.

Check leakage as described below.

LEAKAGE TEST

The AC leakage from any exposed metal part to earth ground and from all exposed metal parts to any exposed metal part having a return to chassis, must not exceed 0.5 mA (500 microamperes.). Leakage current can be measured by any one of three methods.

1. A commercial leakage tester, such as the Simpson 229 or RCA WT-540A. Follow the manufacturers’ instructions to use these instruments.
2. A battery-operated AC milliammeter. The Data Precision 245 digital multimeter is suitable for this job.
3. Measuring the voltage drop across a resistor by means of a VOM or battery-operated AC voltmeter. The “limit” indication is 0.75 V, so analog meters must have an accurate low-voltage scale. The Simpson 250 and Sanwa SH-63Trd are examples of a passive VOM that is suitable. Nearly all battery operated digital multimeters that have a 2 V AC range are suitable. (See Fig. A)

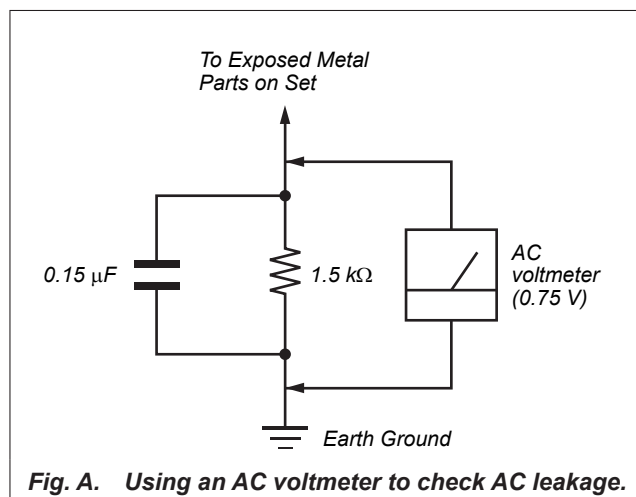

Fig. A. Using an AC voltmeter to check AC leakage.

Notes on chip component replacement

- Never reuse a disconnected chip component.
- Notice that the minus side of a tantalum capacitor may be damaged by heat.

SAFETY-RELATED COMPONENT WARNING!

COMPONENTS IDENTIFIED BY MARK Δ OR DOTTED LINE WITH MARK Δ ON THE SCHEMATIC DIAGRAMS AND IN THE PARTS LIST ARE CRITICAL TO SAFE OPERATION. REPLACE THESE COMPONENTS WITH SONY PARTS WHOSE PART NUMBERS APPEAR AS SHOWN IN THIS MANUAL OR IN SUPPLEMENTS PUBLISHED BY SONY.

ATTENTION AU COMPOSANT AYANT RAPPORT À LA SÉCURITÉ!

LES COMPOSANTS IDENTIFIÉS PAR UNE MARQUE Δ SUR LES DIAGRAMMES SCHÉMATIQUES ET LA LISTE DES PIÈCES SONT CRITIQUES POUR LA SÉCURITÉ DE FONCTIONNEMENT. NE REMPLACER CES COMPOSANTS QUE PAR DES PIÈCES SONY DONT LES NUMÉROS SONT DONNÉS DANS CE MANUEL OU DANS LES SUPPLÉMENTS PUBLIÉS PAR SONY.

TABLE OF CONTENTS

1. SERVICING NOTES	4
2. DISASSEMBLY	
2-1. Case (Entry)	5
2-2. Front Panel Section	6
2-3. Back Panel Section	7
2-4. MAIN Board Section	8
2-5. MAIN Board	9
3. TEST MODE	10
4. FM TUNER CHECK	13
5. DIAGRAMS	
5-1. Block Diagram - ANALOG AUDIO Section -	15
5-2. Block Diagram - DIGITAL Section -	16
5-3. Block Diagram - AMP Section -	17
5-4. Block Diagram - ANALOG VIDEO/USB Section -	18
5-5. Block Diagram - DIGITAL VIDEO Section -	19
5-6. Block Diagram - DISPLAY/POWER Section -	20
5-7. Printed Wiring Board	
- MAIN Board (Component Side) -	22
5-8. Printed Wiring Board	
- MAIN Board (Conductor Side) -	23
5-9. Schematic Diagram - MAIN Board (1/7) -	24
5-10. Schematic Diagram - MAIN Board (2/7) -	25
5-11. Schematic Diagram - MAIN Board (3/7) -	26
5-12. Schematic Diagram - MAIN Board (4/7) -	27
5-13. Schematic Diagram - MAIN Board (5/7) -	28
5-14. Schematic Diagram - MAIN Board (6/7) -	29
5-15. Schematic Diagram - MAIN Board (7/7) -	30
5-16. Printed Wiring Board	
- HDMI Board (Component Side) -	31
5-17. Printed Wiring Board	
- HDMI Board (Conductor Side) -	32
5-18. Schematic Diagram - HDMI Board -	33
5-19. Printed Wiring Board	
- STANDBY DCDC Board (Component Side) -	34
5-20. Printed Wiring Board	
- STANDBY DCDC Board (Conductor Side) -	35
5-21. Schematic Diagram - STANDBY DCDC Board -	36
5-22. Printed Wiring Board - PANEL Section -	37
5-23. Schematic Diagram - PANEL Section -	38
5-24. Printed Wiring Board - FRONT JACK Board -	39
5-25. Schematic Diagram - FRONT JACK Board -	39
5-26. Printed Wiring Board - TUNER1 Board -	39
5-27. Schematic Diagram - TUNER1 Board -	40
5-28. Printed Wiring Board - POWER KEY Board -	41
5-29. Schematic Diagram - POWER KEY Board -	41
5-30. Printed Wiring Board - HEADPHONE Board -	42
5-31. Schematic Diagram - HEADPHONE Board -	42
6. EXPLODED VIEWS	
6-1. Case (Entry) Section	57
6-2. Front Panel Section	58
6-3. Back Panel Section	59
6-4. Chassis Section	60
7. ELECTRICAL PARTS LIST	61

SECTION 1 SERVICING NOTES

**MODEL IDENTIFICATION
-BACK PANEL-**

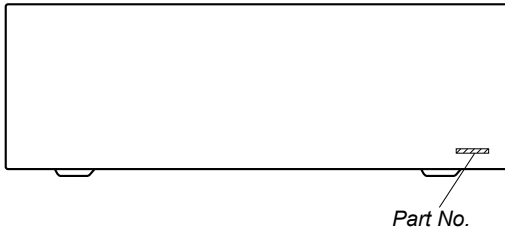

Model	Part No.
DH550: US, Canadian	4-487-917-0□
DH550: AEP, UK	4-487-917-1□
DH550: Australian	4-487-917-2□
DH750: US, Canadian	4-448-923-0□
DH750: AEP, UK	4-448-923-1□
DH750: Australian	4-448-923-2□
DH750: Taiwan	4-448-923-3□
DH750: Mexican	4-448-923-4□
DH750: Brazillian	4-448-923-6□

UNLEADED SOLDER

Boards requiring use of unleaded solder are printed with the lead-free mark (LF) indicating the solder contains no lead.
(Caution: Some printed circuit boards may not come printed with the lead free mark due to their particular size)

LF : LEAD FREE MARK

Unleaded solder has the following characteristics.

- Unleaded solder melts at a temperature about 40 °C higher than ordinary solder.
Ordinary soldering irons can be used but the iron tip has to be applied to the solder joint for a slightly longer time.
Soldering irons using a temperature regulator should be set to about 350 °C.
Caution: The printed pattern (copper foil) may peel away if the heated tip is applied for too long, so be careful!
- Strong viscosity
Unleaded solder is more viscous (sticky, less prone to flow) than ordinary solder so use caution not to let solder bridges occur such as on IC pins, etc.
- Usable with ordinary solder
It is best to use only unleaded solder but unleaded solder may also be added to ordinary solder.

SPECIAL COMPONENT NOTICE

The components identified by mark contain confidential information.

Strictly follow the instructions whenever the components are repaired and/or replaced.

NOTICE POUR COMPOSANTS SPÉCIAUX

Les composants identifiés par la marque contiennent des informations confidentielles.

Suivre scrupuleusement les instructions chaque fois qu'un composant est remplacé et / ou réparé.

NOTE OF REPLACING THE IC2402 ON THE MAIN BOARD

IC2402 on the MAIN board cannot exchange with single. When this part on the MAIN board is damaged, exchange the entire mounted board.

NOTE OF REPLACING THE IC3514 ON THE HDMI BOARD

IC3514 on the HDMI board cannot exchange with single. When this part on the HDMI board is damaged, exchange the entire mounted board.

NOTE OF REPLACING THE IC902 (DH750) ON THE STANDBY DCDC BOARD

IC902 (DH750) on the STANDBY DCDC board cannot exchange with single. When this part on the STANDBY DCDC board is damaged, exchange the entire mounted board.

CAPACITOR ELECTRICAL DISCHARGE PROCESSING

When checking the board, the electrical discharge is necessary for the electric shock prevention.

Connect the resistor to both ends of respective capacitors.

- Main Board
C930, C931

- MAIN BOARD (Conductor side) -

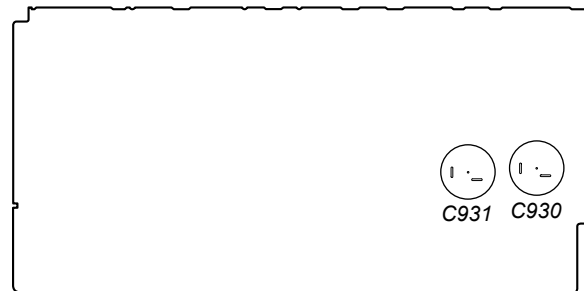

(To both ends of each capacitor)

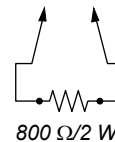

SECTION 2 DISASSEMBLY

Note: This set can be disassembled according to the following sequence.

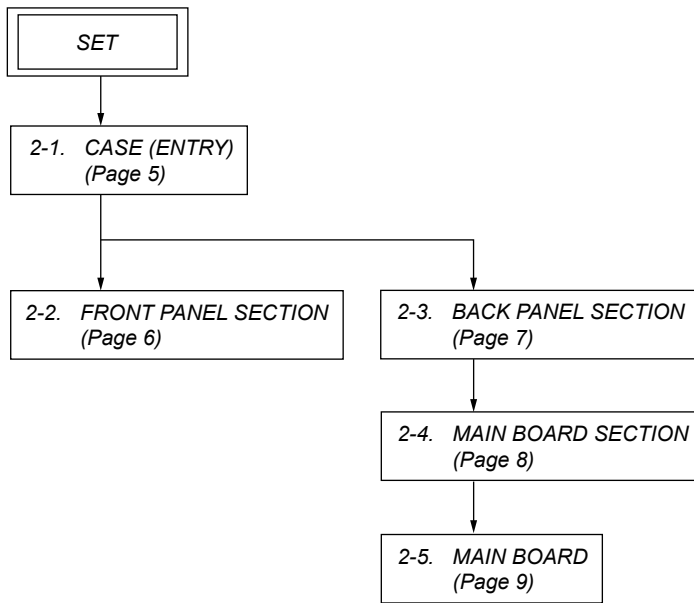

Note: Follow the disassembly procedure in the numerical order given.

2-1. CASE (ENTRY)

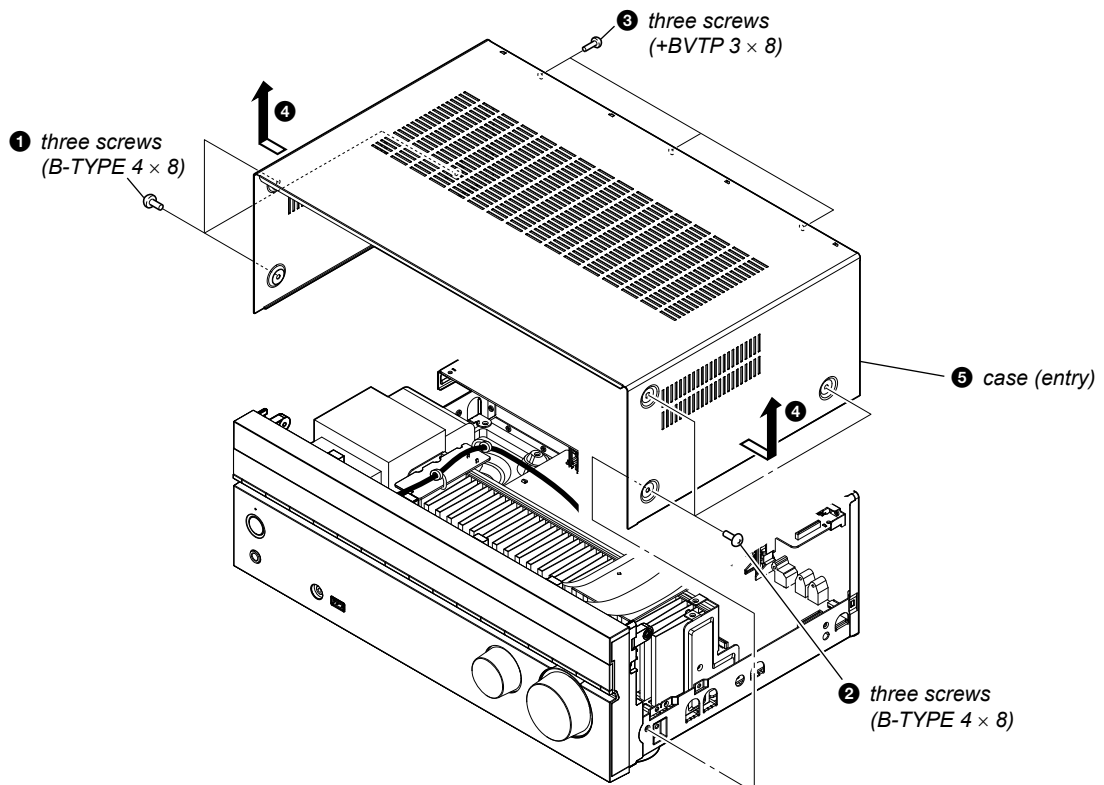

2-2. FRONT PANEL SECTION

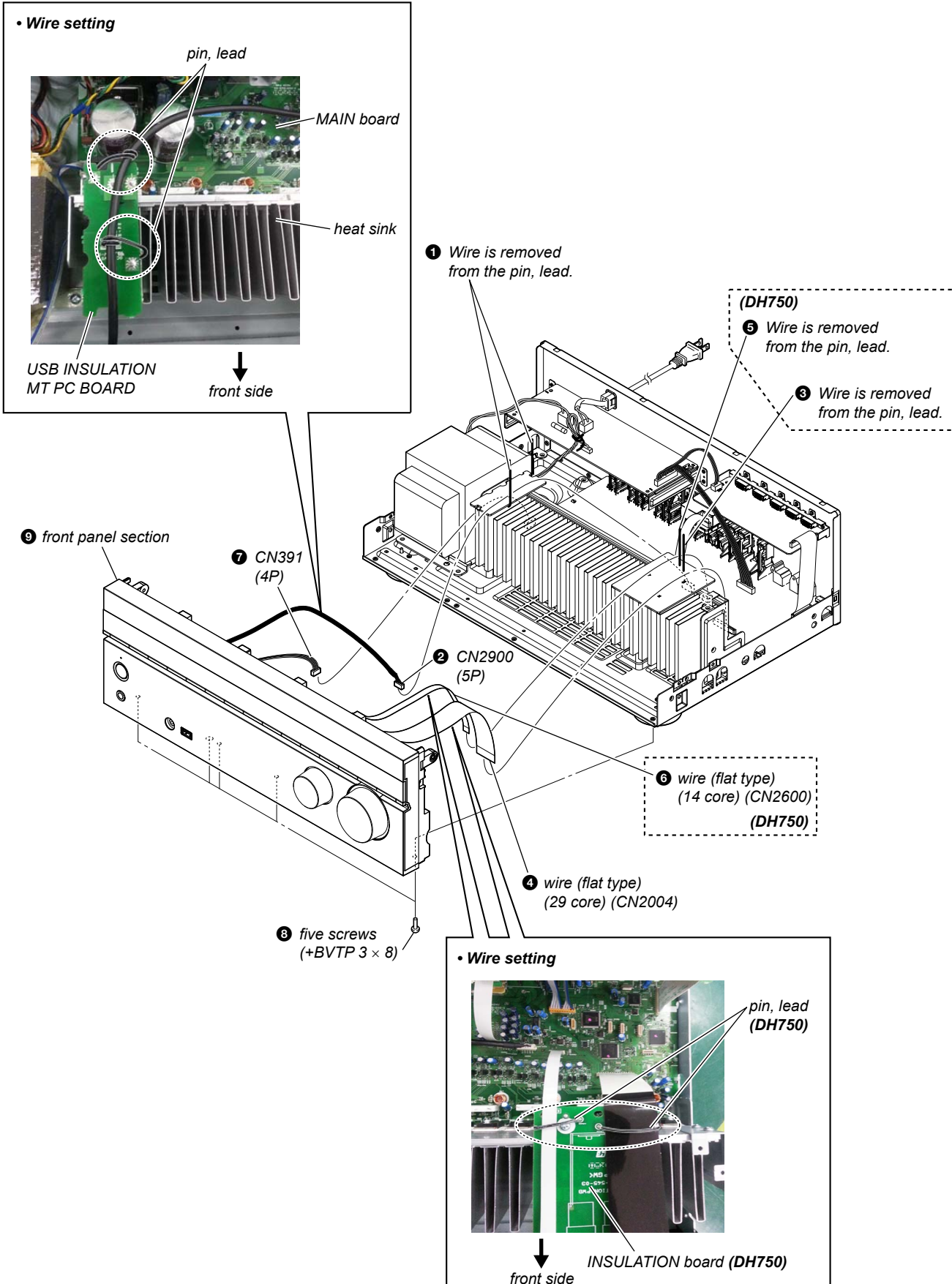

2-3. BACK PANEL SECTION

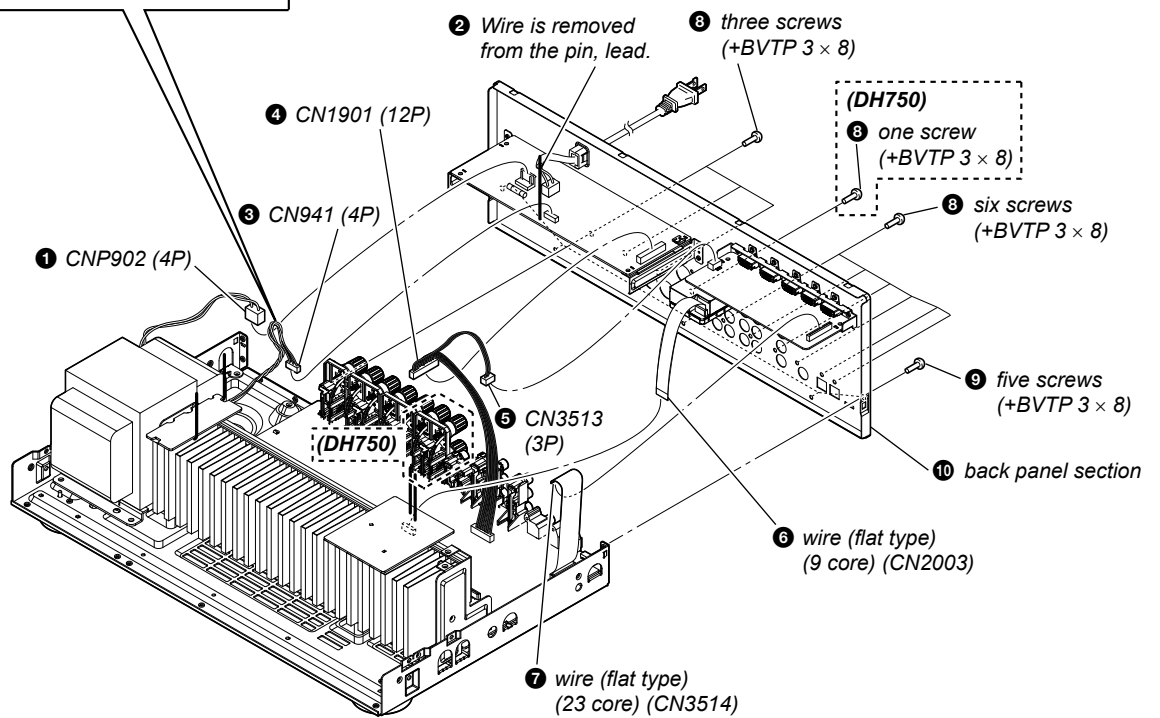
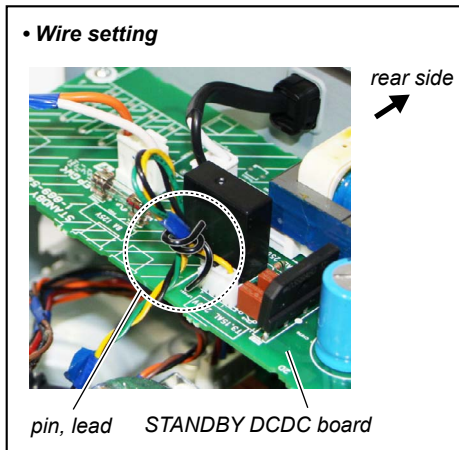

2-4. MAIN BOARD SECTION

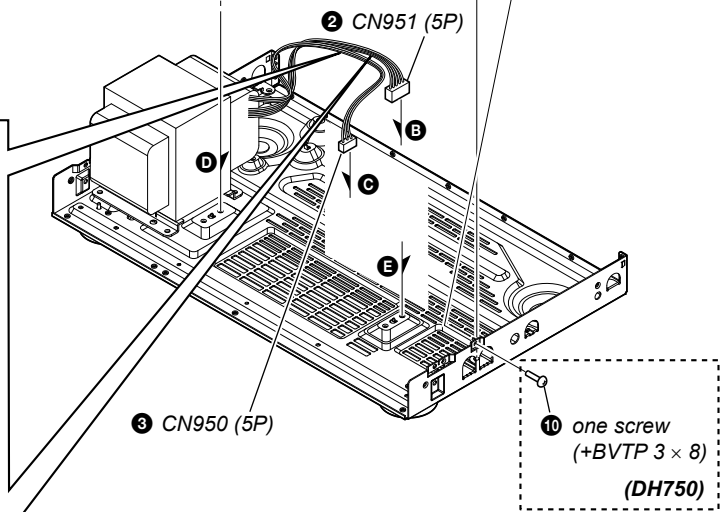
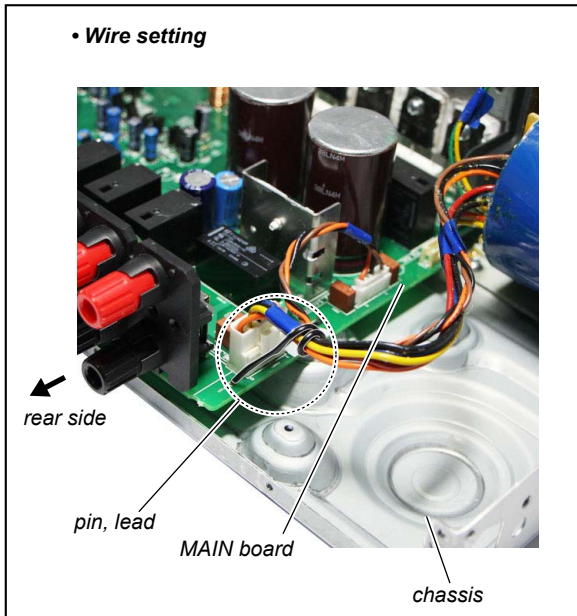
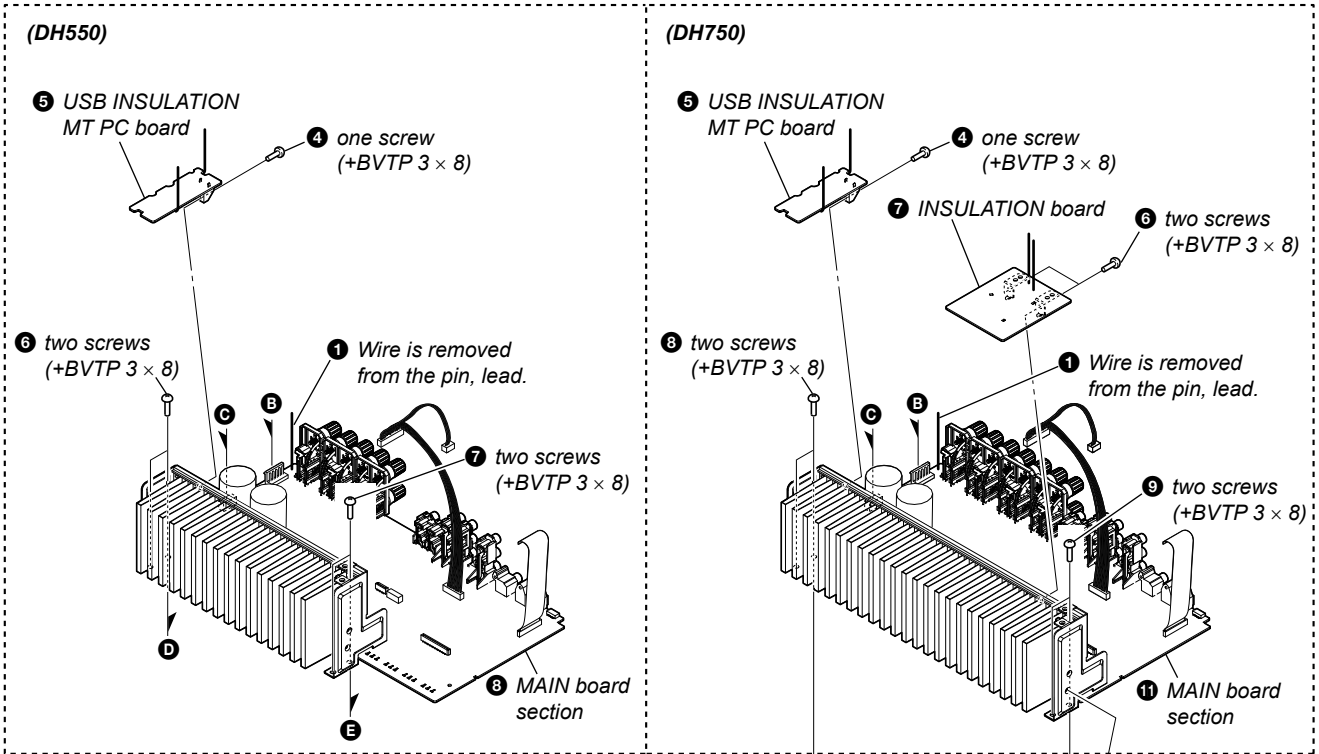

2-5. MAIN BOARD

Note: This illustration sees the MAIN board from back side.

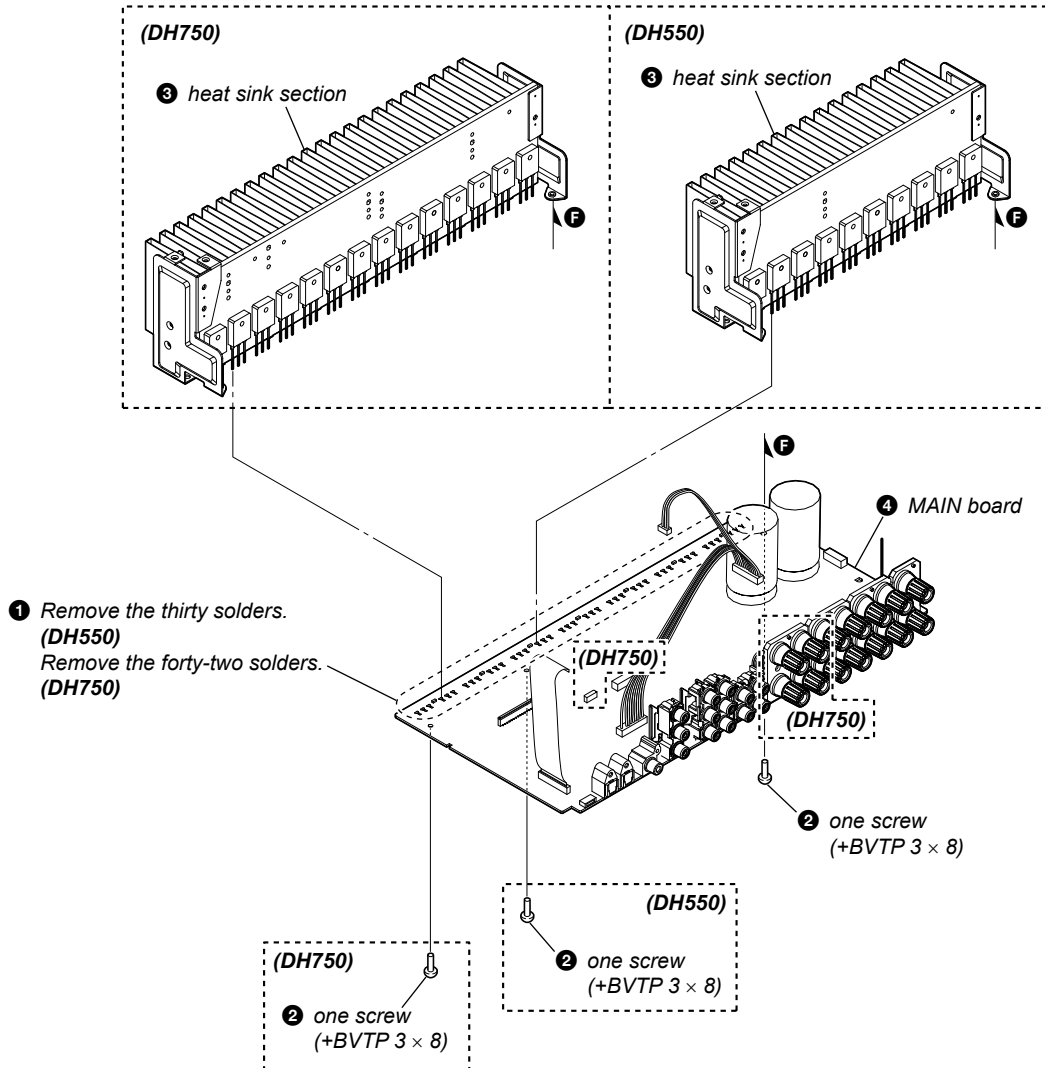

SECTION 3 TEST MODE

TUNER AM STEP CHANGE MODE

(US and Canadian models only)

Either the 9 kHz step or 10 kHz step can be selected for the AM channel step.

Procedure:

1. Press the [I/⏻] button to turn on the main power.
2. Turn the [INPUT SELECTOR] knob to select the "AM TUNER".
3. Press the [I/⏻] button to turn off the main power.
4. While pressing the [TUNING MODE] button, press the [I/⏻] button to turn on the main power.
5. Either the message "10K Step" or "9K Step" appears.
6. Repeat step (4) to select desired step.

VACUUM FLOURESCENT DISPLAY TEST MODE

All flourescent segments are tested.

When this test is activated, all segments light on at the same time, then each segment lights on one after another.

Procedure:

While pressing [SPEAKERS] and [DIMMER] buttons simultaneously, press the [I/⏻] button to turn on the main power.

1. ALL segments light on.

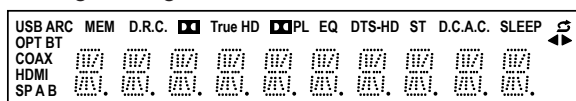

2. Press the [DISPLAY] button to confirm display as below.

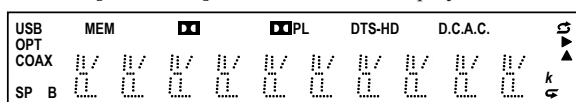

3. Press the [DISPLAY] button to confirm display as below.

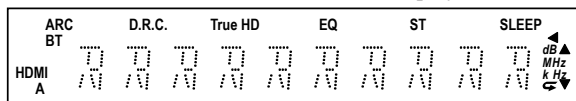

4. Press the [DISPLAY] button, all segments light off.

SOUND FIELD CLEAR MODE

The preset sound field is cleared when this mode is activated.

Use this mode before returning the product to clients upon completion of repair.

Procedure:

1. While pressing [MUSIC] button, press the [I/⏻] button to turn on the main power.
2. The message "S.F. CLEAR" appears for a moment and initialization is performed.

SOFTWARE VERSION DISPLAY MODE

The software version is displayed.

Procedure:

1. While pressing [A.F.D./2CH] and [PURE DIRECT] buttons simultaneously, press the [I/⏻] button to turn on the main power.
2. The message "H55 XXX" or "H75 XXX" appears.
XXX: Area display
Each time the [DISPLAY] button is pressed, "SYS. vX.XX", "MAIN vX.XX", "VIDEO vX.XX", "OSD vX.XX" and "SFLASHvX.XX" appear in this order, and returns to the "H55 XXX" or "H75 XXX" display.
X.XX: Software version

KEY CHECK MODE

Each button can be checked.

Procedure:

1. While pressing [SPEAKERS] and [PURE DIRECT] buttons simultaneously, press the [I/⏻] button to turn on the main power.
2. The message "REST 12" appears.
Every pressing of any button other than the [I/⏻] counts down the buttons.
3. The buttons which are already counted once are not counted again.
4. When all buttons are pressed, "REST 00" appears.

SWAP ALL MODE

The signal will be swap to all channels so that all speakers will have sound output.

Procedure:

1. While pressing [PURE DIRECT] and [MOVIE] buttons simultaneously, press the [I/⏻] button to turn on the main power.
2. "SWAP MODE" appears.

INITIALIZE MODE

All preset contents are cleared when this mode is activated. Use this mode before returning the product to clients upon completion of repair.

(a) SHIPMENT MODE

Procedure:

1. While pressing [A.F.D./2CH] and [DIMMER] buttons simultaneously, press the [I/⏻] button to turn on the main power.
2. The message "CLEARING" appears and the memories are reset to the default values.
3. When done, the message "CLEARED *" appears, the set will power off.

(b) ALL CLEAR INITIALIZE

Procedure:

1. While pressing [A.F.D./2CH] and [DISPLAY] buttons, press the [I/⏻] button to turn on the main power.
2. The message "CLEARING" appears and the memories are reset to the default values.
3. When done, the message "CLEARED *" appears, the set will power on.

(c) USER INITIALIZE

Procedure:

1. Hold the [I/⏻] button for 5 seconds.
2. The message "CLEARING" appears on the display.
3. After few seconds, "CLEARED *" appears.

PROTECTOR AUTO OFF

To disable auto off after protector occur.

Procedure:

1. While pressing [DISPLAY] and [MOVIE] buttons simultaneously, press the [I/⏻] button to turn on the main power.
2. "PROTEVER" appears and switch on the set.

DCAC TEST MODE

To test audio output from mic input and speakers.

Procedure:

1. While pressing [MUSIC] and [DIMMER] buttons simultaneously, press the [I/⏻] button to turn on the main power.
2. The message "MIC" appears.
MIC: mode that output audio from mic input

HISTORY MODE

The state that the set is used is memorized.

Procedure:

1. While pressing [TUNING MODE] and [DISPLAY] buttons simultaneously, press the [I/⏻] button to turn on the power and "HISTORY" is displayed.
2. Each time the [↑][↓] key of remote commander is pressed, the item is switched in order as follows.

Items	Display
Protector Count	C O U N T x x x
Total Power ON time	T x x x x x H x x M
Main Power On	M x x x x x H x x M
Protector type	P R O T x x x x
Sound Field	S N D F I E L D
Function	F U N C T I O N
Input Mode	I N P M O D E
Digital Select	D I G S E L E C T
Stream	S T R E A M I N F O
Channel Config	C O N F x x x x x
Headphone	H E A D P H x x x
Volume	V O L _ x x
Muting	M U T I N G _ x x
Bass	B A S S x x x
Treble	T R E B x x x
Front Level	F x x x / x x x
Center Level	C x x x / x x x
Surround Level	S x x x / x x x
Surround Back Level (Only for STR-DH750)	B x x x / x x x
Front Height Level (Only for STR-DH750)	H x x x / x x x
Temperature	T E M P _
Total Power On	T x x x x x H x x M
Main Power On	M x x x x x H x x M
Power On Count	R E B O X _ x x

USB UPDATE TEST MODE

To update microcontroller software through USB.

Procedure:

1. Plug in USB device in power off condition.
2. While pressing [TUNING MODE] and [PURE DIRECT] buttons simultaneously, press the [I/⏻] button to turn on the main power.
3. The message "UPDATING" appears.
4. If the updating progress succeeds, the message "COMPLETE" appears.
5. If the updating progress fails, the message "ERROR" appears.

USB UPDATE VERSION MODE

Function that displays the version number of all firmware to check whether USB Update Test is necessary or not.

Procedure:

1. While pressing [TUNING MODE] and [DIMMER] buttons, press the [I/⏻] button to turn on the main power.
2. The message "VER X.XXX" is displayed. "X.XXX" is calculated by adding all firmware version.

Example:

$$(MCU \text{ ver.} + \text{VIDEO ver.} + \text{DSP ver.} + \text{OSD ver.} + 6)/10 = \text{USB Update version}$$

$$MCU = 1.01, \text{VIDEO} = 1.04, \text{DSP} = 1.02, \text{OSD} = 1.03$$

↓

$$(1.01 + 1.04 + 1.02 + 1.03 + 6)/10 = 1.010$$

$$1.010 = \text{X.XXX}$$

FIX MODEL AND DESTINATION MODE

This mode is to fix the set for model & destination.

When turning on the set, the message below appears if the setting is not fixed with its model or destination or both (model & destination).

Items	Display
MODEL & AREA NOT FIX	M D . D S T . U N F I X
MODEL NOT FIX	M O D E L . U N F I X
AREA/DESTINATION NOT FIX	D E S T . U N F I X

Procedure:

1. Press the [I/⏻] button to turn on the main power.
2. While pressing [DISPLAY] button, press and release the [A.F.D./2CH], [MOVIE], [MUSIC] button in order, the message "SPECIALIZE" appears.
3. Press the [↑] or [↓] key of the remote commander, the message "<SPECIAL>" appears.
4. Press the [-+] key of the remote commander to enter the Special Menu List.
5. Each time the [↑] or [↓] key of the remote commander is pressed, the item is switched in order as follows.

Items	Display
MODEL setting	M O D E L
DESTINATION setting	D E S T I N Y
MODEL & DESTINATION check	M O D E L + D E S T
SYSTEM VERSION	S Y S v X . X X X
MAIN VERSION	M A I N v X . X X
VIDEO VERSION	V I D E O v X . X X
OSD VERSION	O S D v X . X X
DSP SFLASH1 VER	S F L A S H v X . X X

6. Go to MODEL setting and press the [-+] key of remote commander.
7. Either one of the message as below appears.

Items	Display
Model not fix yet	M O D E L . U N F I X
Model STR-H55 fix	H 5 5 f i x
Model STR-H75 fix	H 7 5 f i x

8. Press the [↑] or [↓] key of remote commander to set model info as "H55 fix" or "H75 fix" if message "MODEL UNFIX" appears.
9. Press the [-+] key of remote commander to select the model.
10. The message "MODEL" appears.
11. Go to DESTINATION setting and press the [-+] key of remote commander.

12. Either one of the display below appears according to the destination of the set.

Items	Display
Destination	D E S T U N F I X
Destination UCA fix	U C A f i x
Destination J fix	J f i x
Destination TW/SA2 fix	T W f i x
Destination SP/CN fix	C N f i x
Destination KR fix	K R f i x
Destination E2/E3 fix	C H 3 f i x
Destination CEL fix	C E L f i x
Destination AU fix	A U f i x
Destination SP fix	S P f i x
Destination E51 fix	E 5 1 f i x
Destination BR fix	B R f i x
Destination AR fix	A R f i x
Destination MX fix	M X f i x

13. Press the [↑] or [↓] key of remote commander to set destination info if message "DEST UNFIX" appears.
14. Press the [-+] key of remote commander to select the destination.
15. The message "DESTINY" appear.
16. Go to MODEL & DESTINATION check and press the [-+] key of remote commander.
17. Either one of the message as below appears.

Items	Display
MODEL & AREA NOT FIX	M D . D S T . U N F I X
MODEL NOT FIX	M O D E L . U N F I X
DESTINATION NOT FIX	D E S T . U N F I X
STR-H55	H 5 5 x x x
STR-H75	H 7 5 x x x

xxx: Area display

18. Repeat step (6) onwards if message "MD.DST.UNFIX" appears.
19. Repeat step (6) until step (10) and continue with step (16) onwards if message "MODEL.UNFIX" appears.
20. Repeat step (13) onwards if message "DEST. UNFIX" appears.
21. Set need to be reset and updated again if the message appeared incorrectly.
22. Press the [↑] or [↓] key of remote commander goes to "MD. DST.UNFIX".
23. Press the [-+] key of remote commander.
24. The set will power off and then power on by itself.
25. Start the setting again from step (1) onwards.
26. Perform SHIPMENT MODE if the message appears correctly.
27. The set will be power off itself and can be used as normal by pressing [I/⏻] button.

STR-DH550/DH750

SECTION 4

FM TUNER CHECK

MHL VBUS TEST MODE

To display MHL VBUS status

Procedure:

1. Press the [I/⏻] button to turn on the main power.
2. While pressing [DISPLAY] button, press and release the [MUSIC], [MOVIE], [A.F.D./2CH] button in order, the message "VBUS STAT" appears.
3. Press the [-+] key of the remote commander to check the items.

Items	Display
No Error	N O E R O R
Current Limited	C U R L I M I T D
Current Stopped	C U R S T O P P D

FM AUTO STOP CHECK

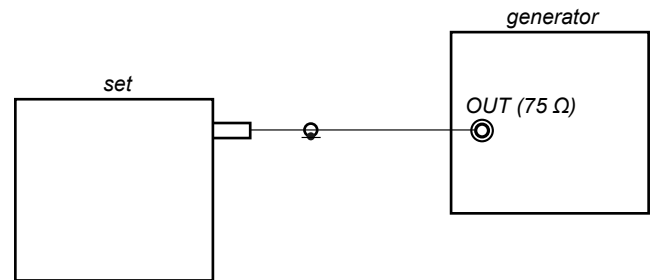

Procedure:

1. Turn on the set.
2. Input the following signal from Signal Generator to FM antenna input directly.

* Carrier Frequency: A=87.5 MHz, B=98 MHz, C=108 MHz
 Deviation : 75 kHz
 Modulation : 1 kHz
 ANT input : 35 dBu (EMF)

Note: Use 75 ohm "coaxial cable" to connect SG and the set.
 You cannot use video cable for checking.
 Please use SG whose output impedance is 75 ohm.

3. Set to FM tuner function and scan the input FM signal with automatic scanning.
4. Confirm that input Frequency of A, B and C are detected and automatic scanning stops.

The stop of automatic scanning means "The station signal is received in good condition."

SECTION 5
DIAGRAMS

• Circuit Boards Location

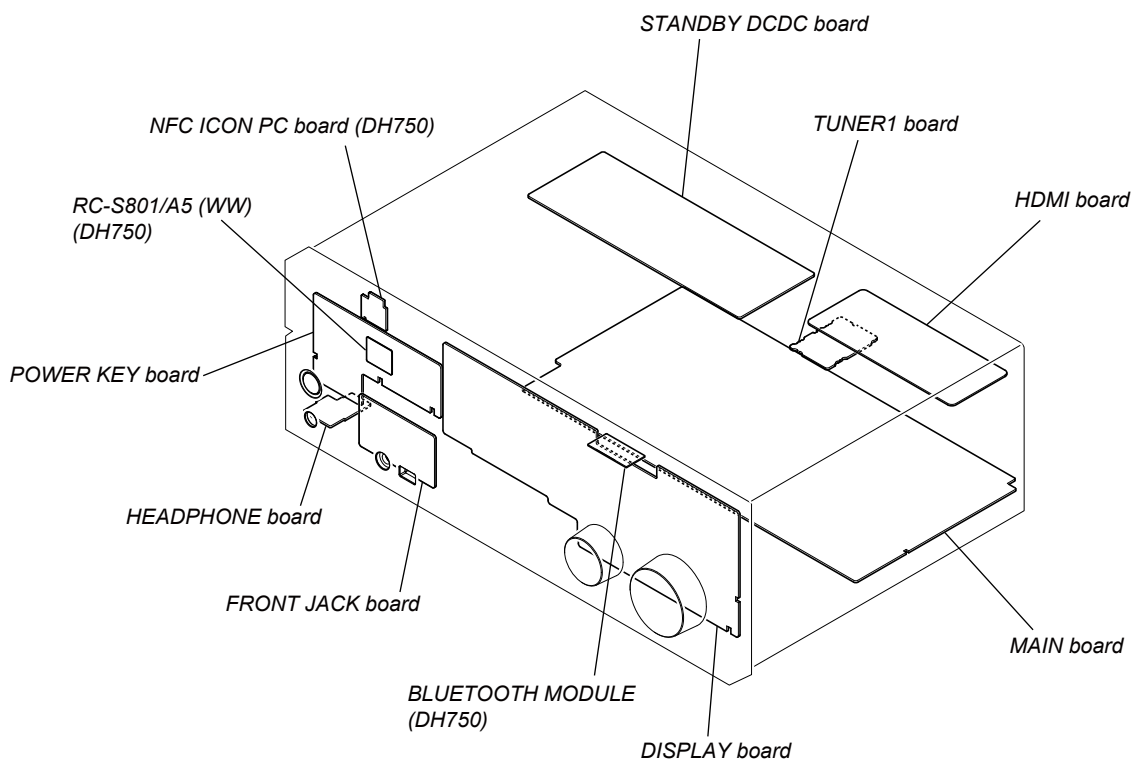

5-1. BLOCK DIAGRAM – ANALOG AUDIO Section –

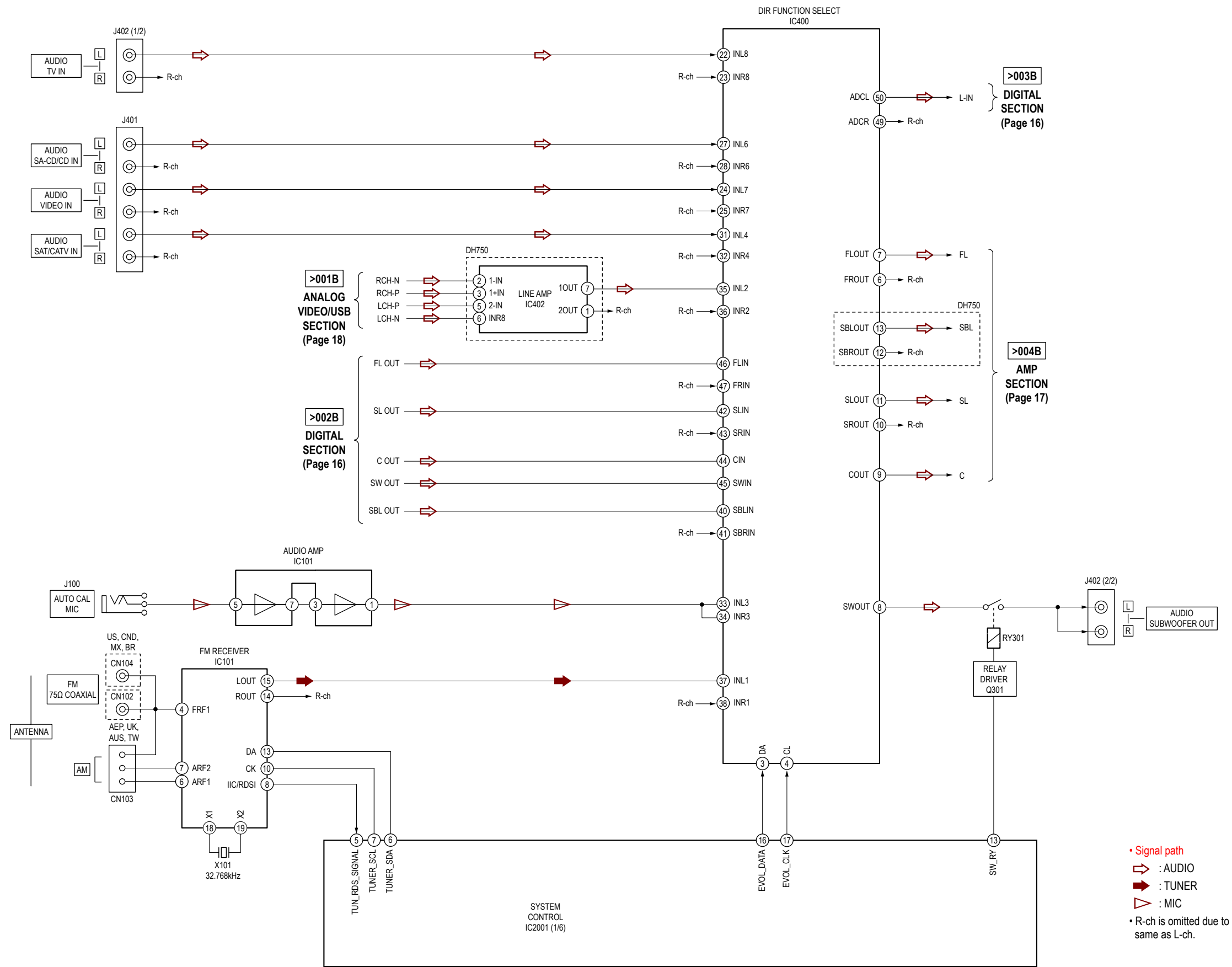

5-2. BLOCK DIAGRAM – DIGITAL Section –

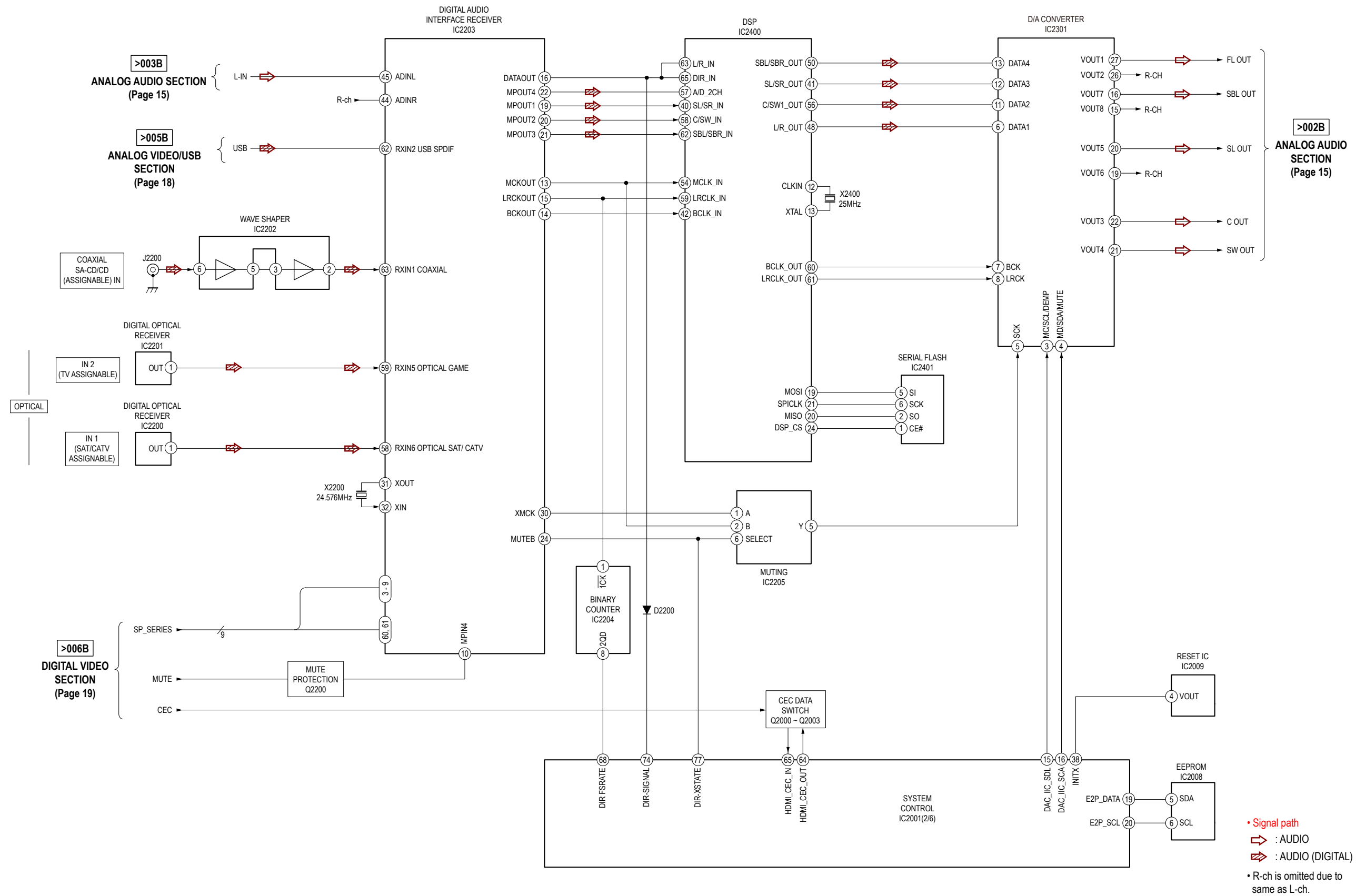

5-3. BLOCK DIAGRAM – AMP Section –

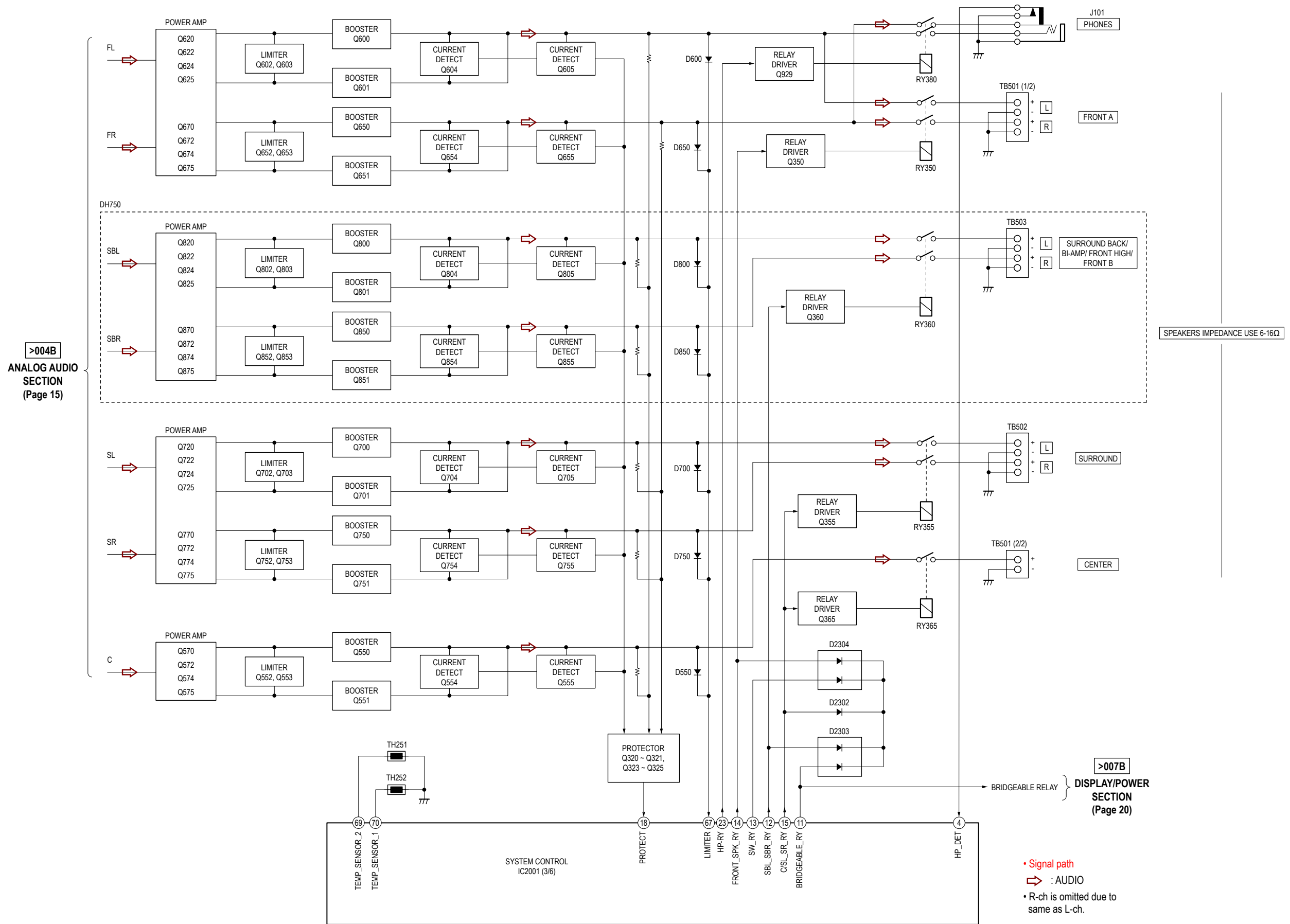

5-4. BLOCK DIAGRAM – ANALOG VIDEO/USB Section –

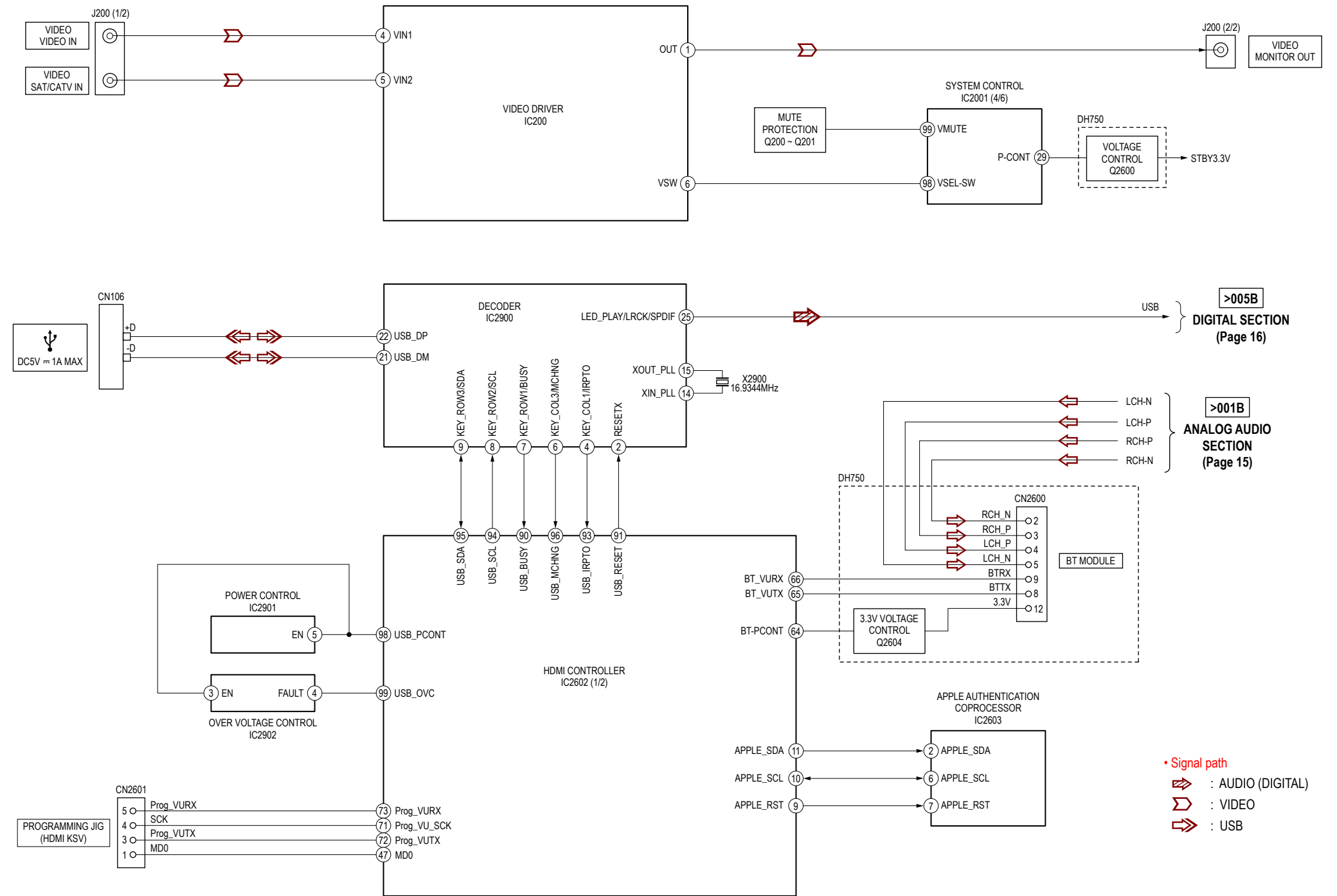

5-5. BLOCK DIAGRAM – DIGITAL VIDEO Section –

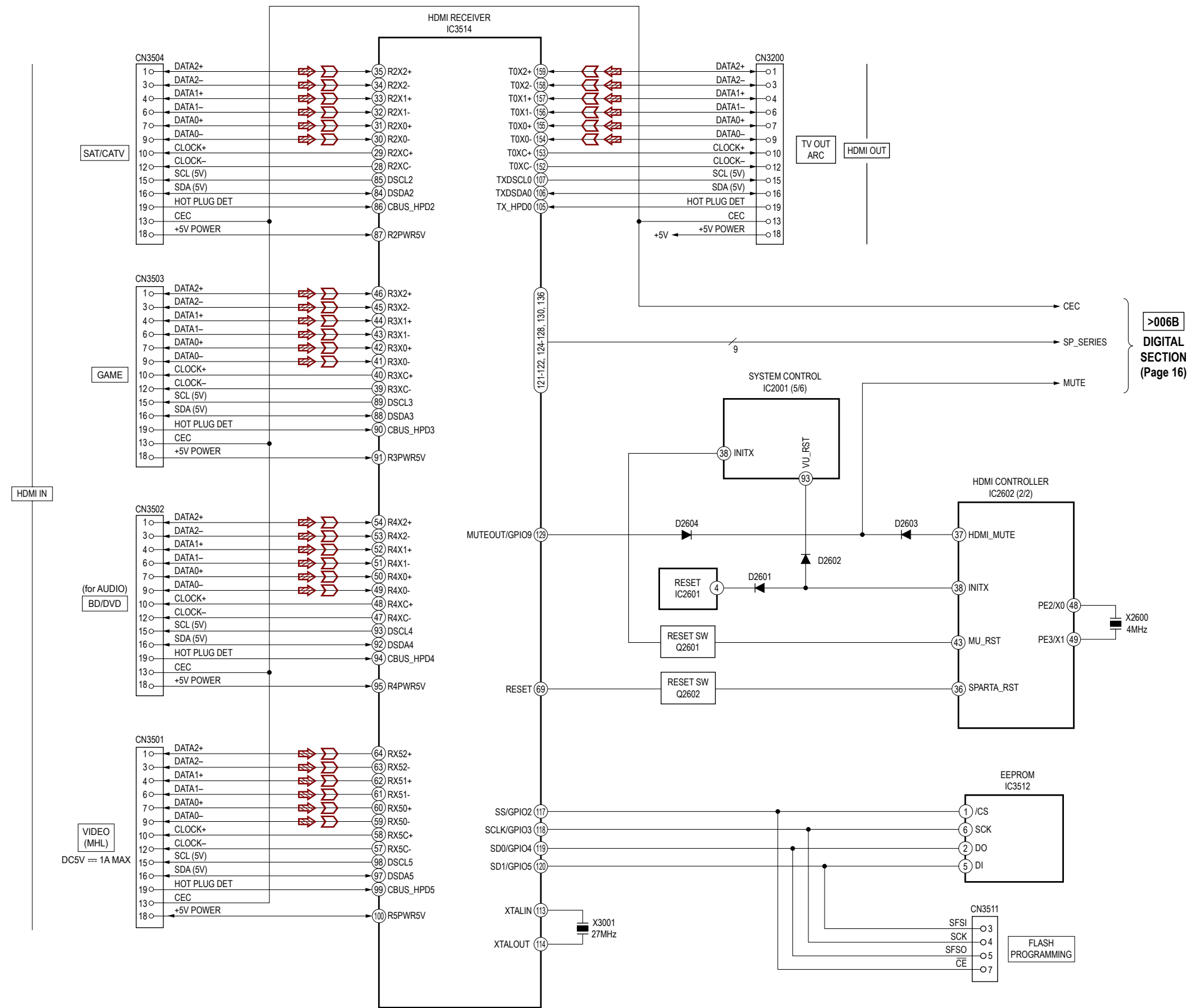

>006B
DIGITAL SECTION
(Page 16)

5-6. BLOCK DIAGRAM – DISPLAY/POWER Section –

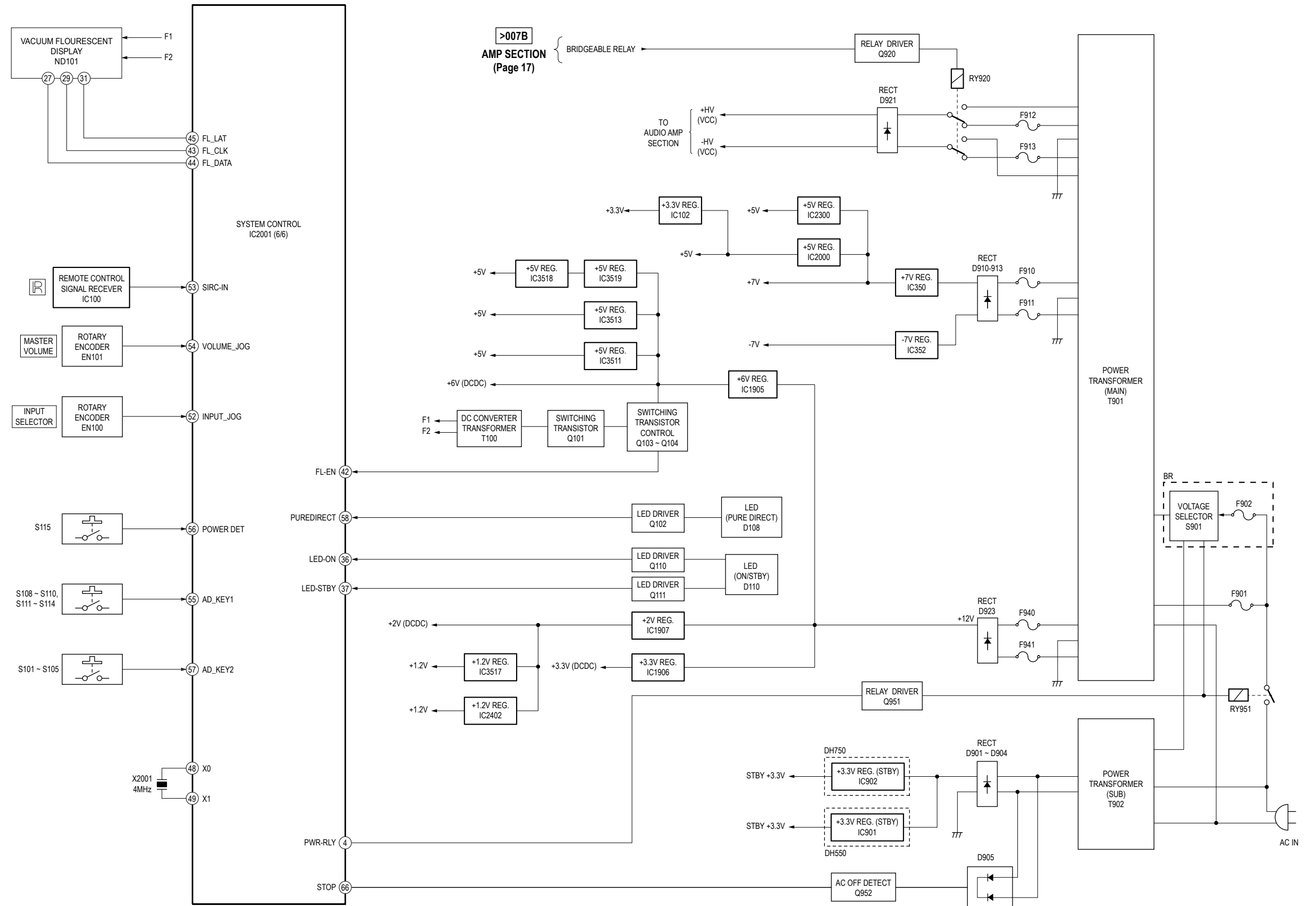

THIS NOTE IS COMMON FOR PRINTED WIRING BOARDS AND SCHEMATIC DIAGRAMS.
(In addition to this, the necessary note is printed in each block.)

For Printed Wiring Boards.

Note:

- : Parts extracted from the component side.
- △ : internal component.
- : Pattern from the side which enables seeing.

Caution:

Pattern face side: Parts on the pattern face side seen (Conductor Side) from the pattern face are indicated.
Parts face side: Parts on the parts face side seen from (Component Side) the parts face are indicated.

Abbreviation

- AUS : Australian model
- BR : Brazillian model
- CND : Canadian model
- MX : Mexican model
- TW : Taiwan model

For Schematic Diagrams.

Note:

- All capacitors are in μF unless otherwise noted. (p: pF) 50 WV or less are not indicated except for electrolytics and tantalums.
- All resistors are in Ω and $1/4\text{ W}$ or less unless otherwise specified.
- △ : internal component.
- ⊞ : nonflammable resistor.
- ⊞ : fusible resistor.
- : panel designation.

Note:

The components identified by mark △ or dotted line with mark △ are critical for safety. Replace only with part number specified.

Note:

Les composants identifiés par une marque △ sont critiques pour la sécurité. Ne les remplacer que par une pièce portant le numéro spécifié.

- : B+ Line.
- - - : B- Line.
- Voltages and waveforms are dc with respect to ground under no-signal (detuned) conditions. no mark: FM
- Voltages are taken with VOM (Input impedance 10 M Ω). Voltage variations may be noted due to normal production tolerances.
- Waveforms are taken with a oscilloscope. Voltage variations may be noted due to normal production tolerances.
- Circled numbers refer to waveforms.
- Signal path.
 - ⇨ : AUDIO
 - ⇨ : TUNER
 - ⇨ : USB
 - ⇨ : VIDEO
 - ⇨ : AUDIO (DIGITAL)
 - ⇨ : MIC
- Abbreviation
 - AUS : Australian model
 - BR : Brazillian model
 - CND : Canadian model
 - MX : Mexican model
 - TW : Taiwan model

Waveforms

- HDMI Board -

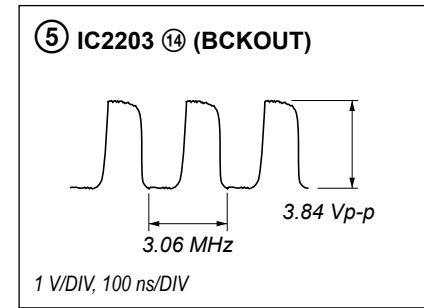
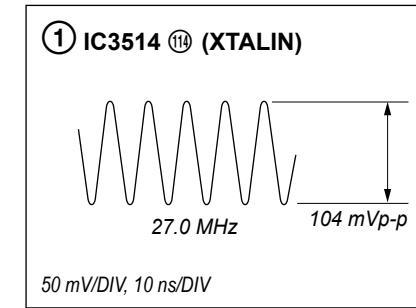

- MAIN Board -

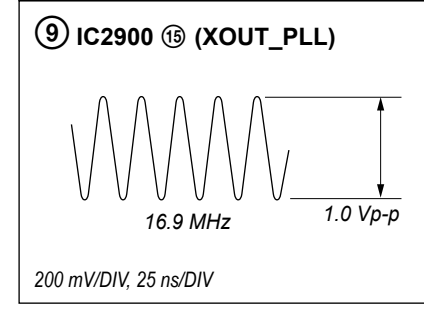
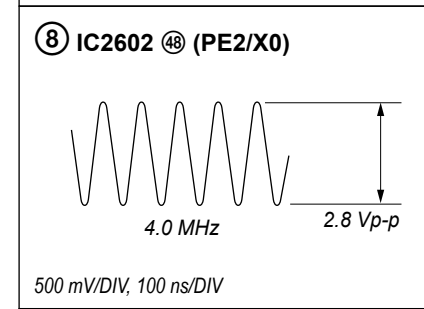
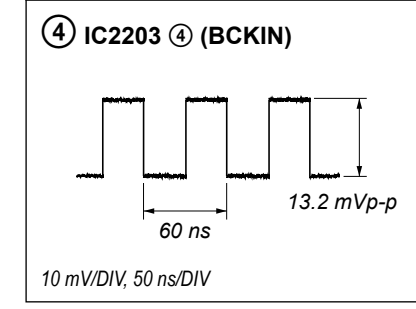
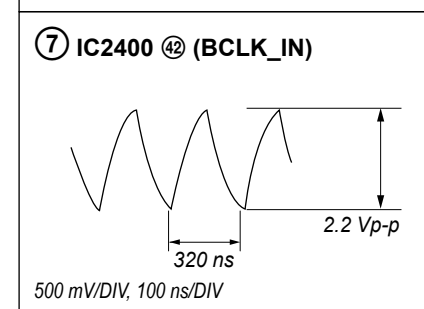
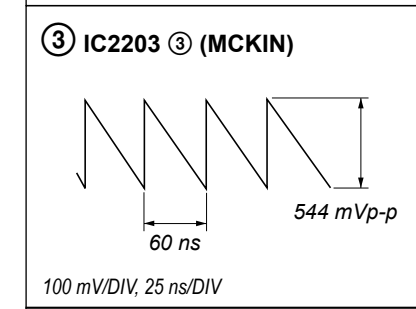
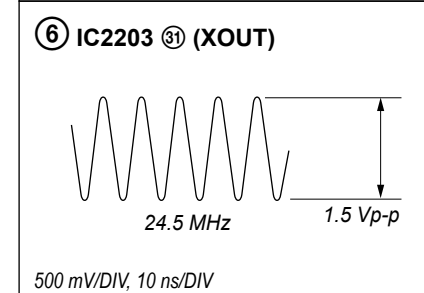
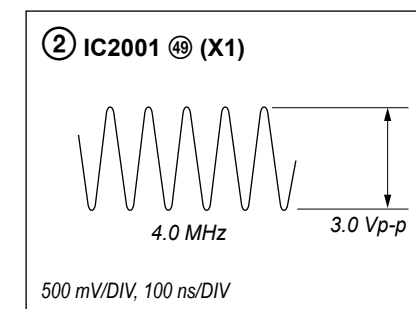

5-7. PRINTED WIRING BOARD – MAIN Board (Component Side) – • See page 14 for Circuit Boards Location. • : Uses unleaded solder.

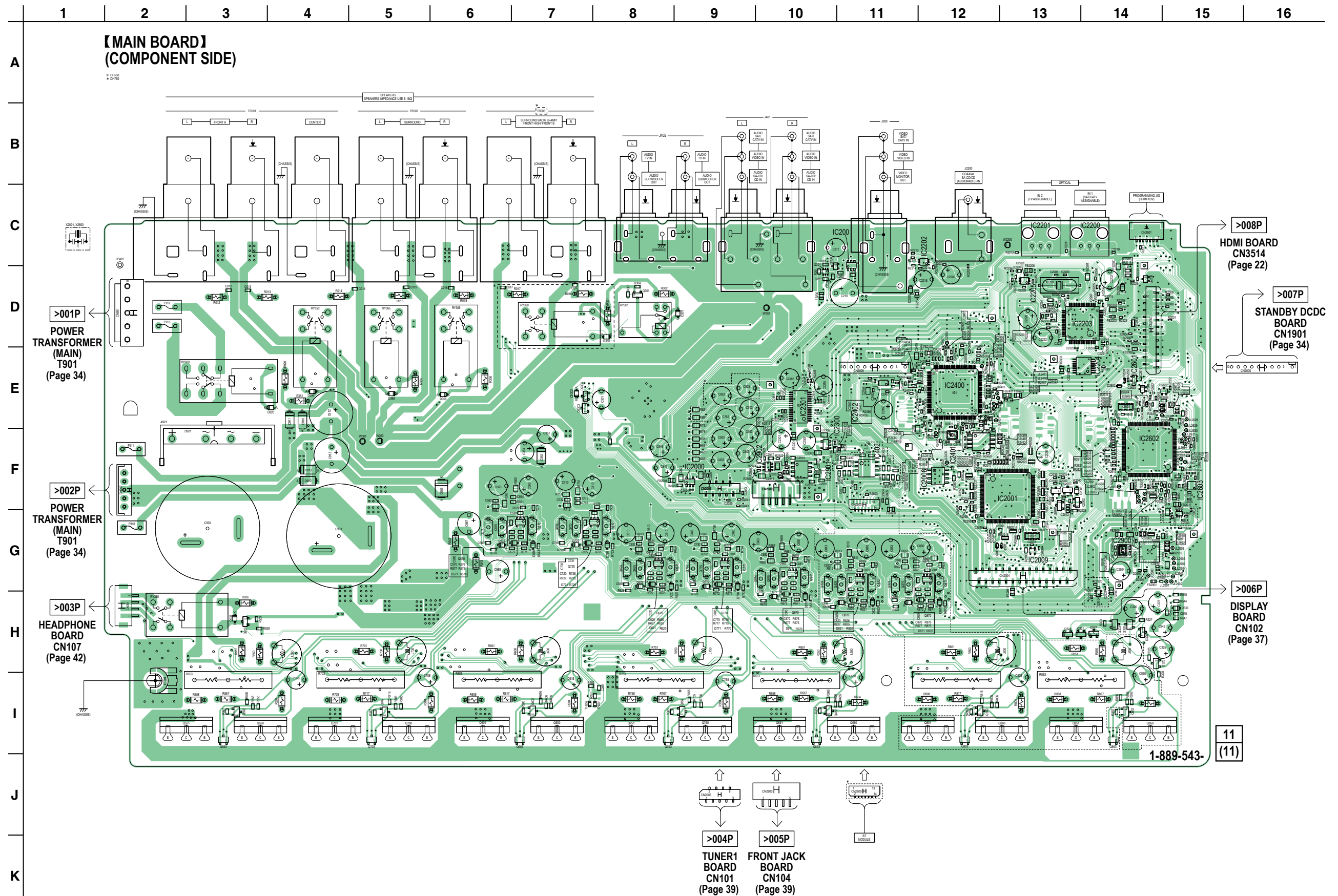

Note: IC2402 on the MAIN board cannot exchange with single. When this part on the MAIN board is damaged, exchange the entire mounted board.

5-8. PRINTED WIRING BOARD – MAIN Board (Conductor Side) – • See page 14 for Circuit Boards Location. • : Uses unleaded solder.

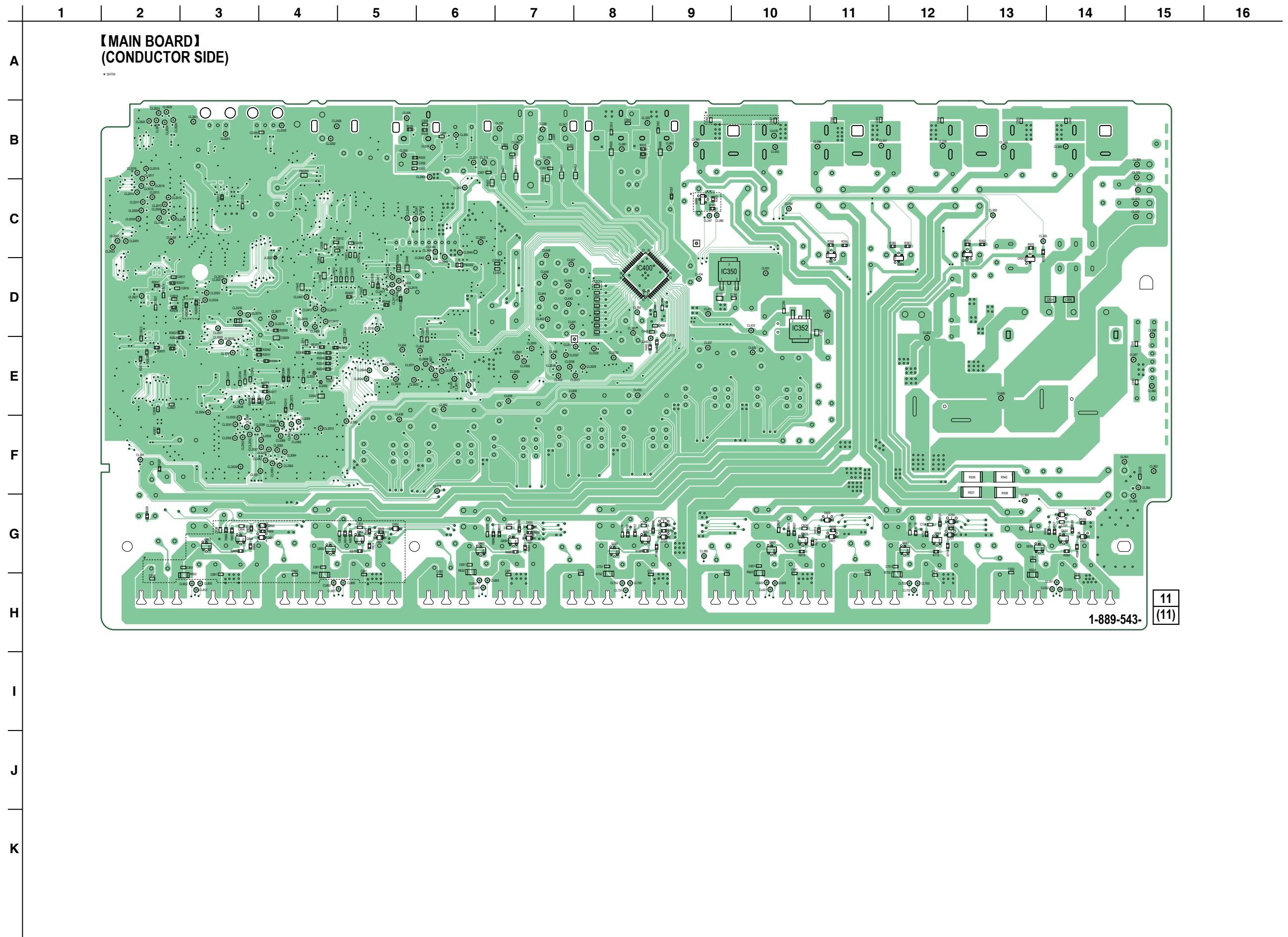

5-9. SCHEMATIC DIAGRAM – MAIN Board (1/7) –

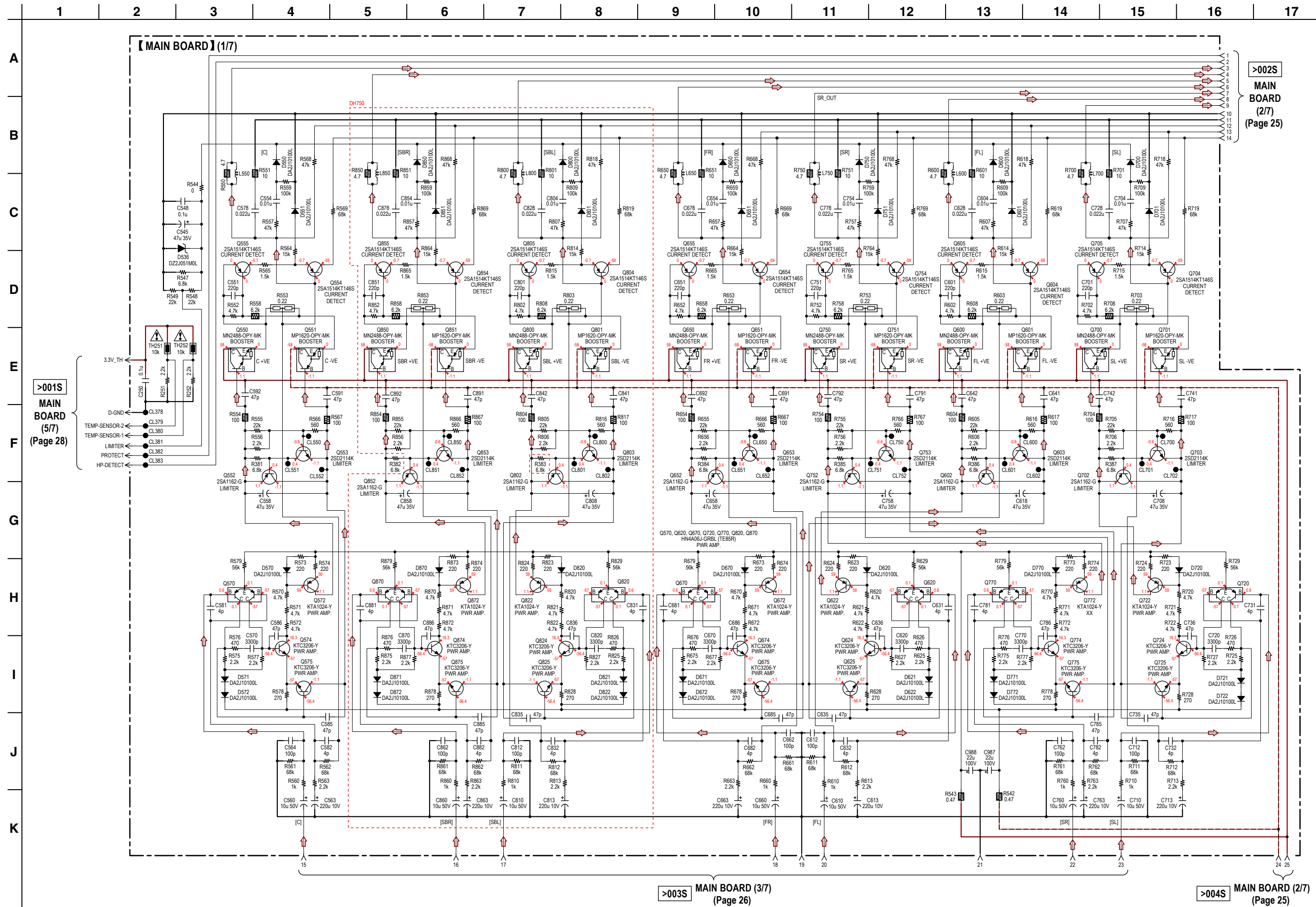

5-10. SCHEMATIC DIAGRAM – MAIN Board (2/7) –

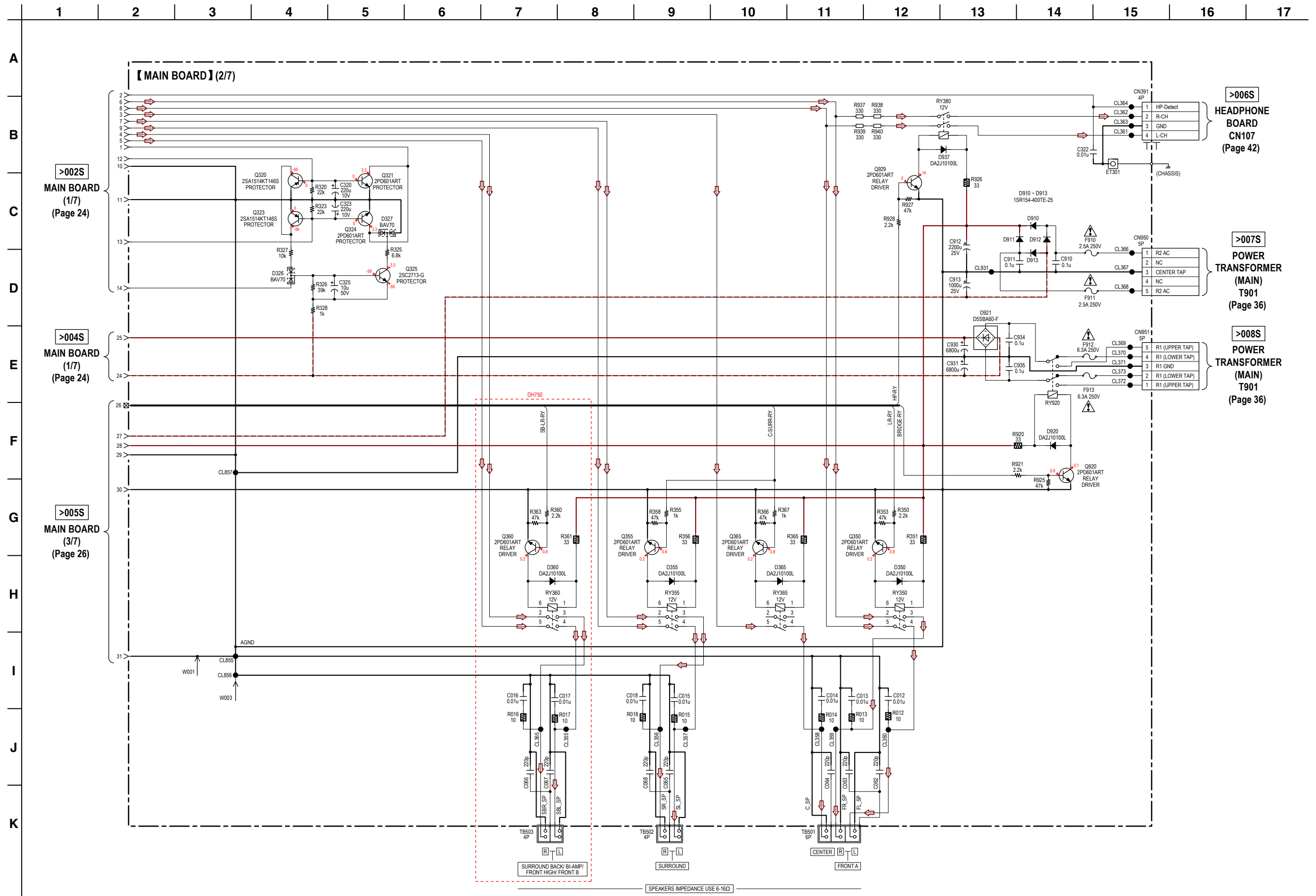

5-11. SCHEMATIC DIAGRAM – MAIN Board (3/7) – • See page 43 for IC Block Diagrams.

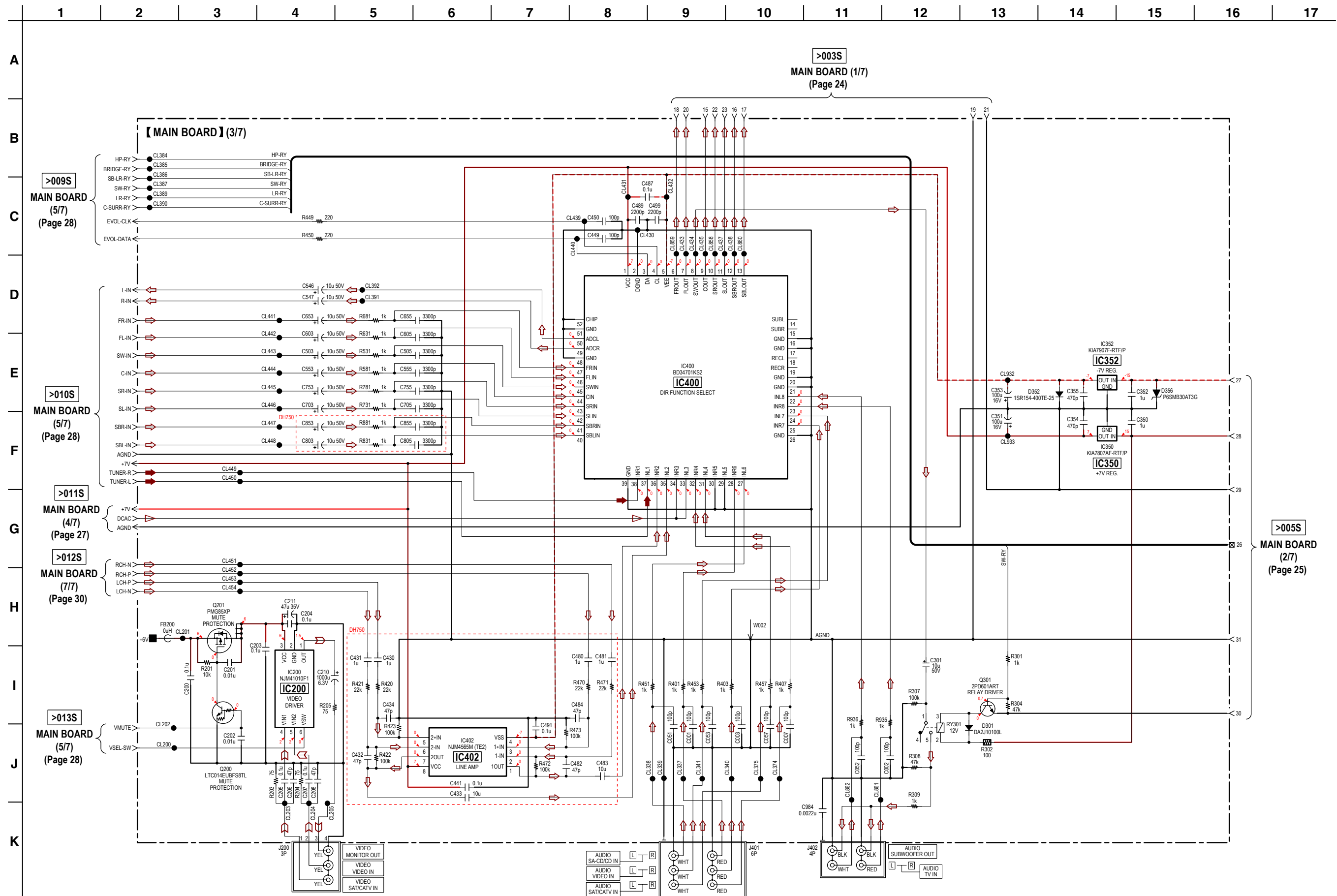

5-13. SCHEMATIC DIAGRAM – MAIN Board (5/7) – • See page 21 for Waveforms. • See page 43 for IC Block Diagrams.

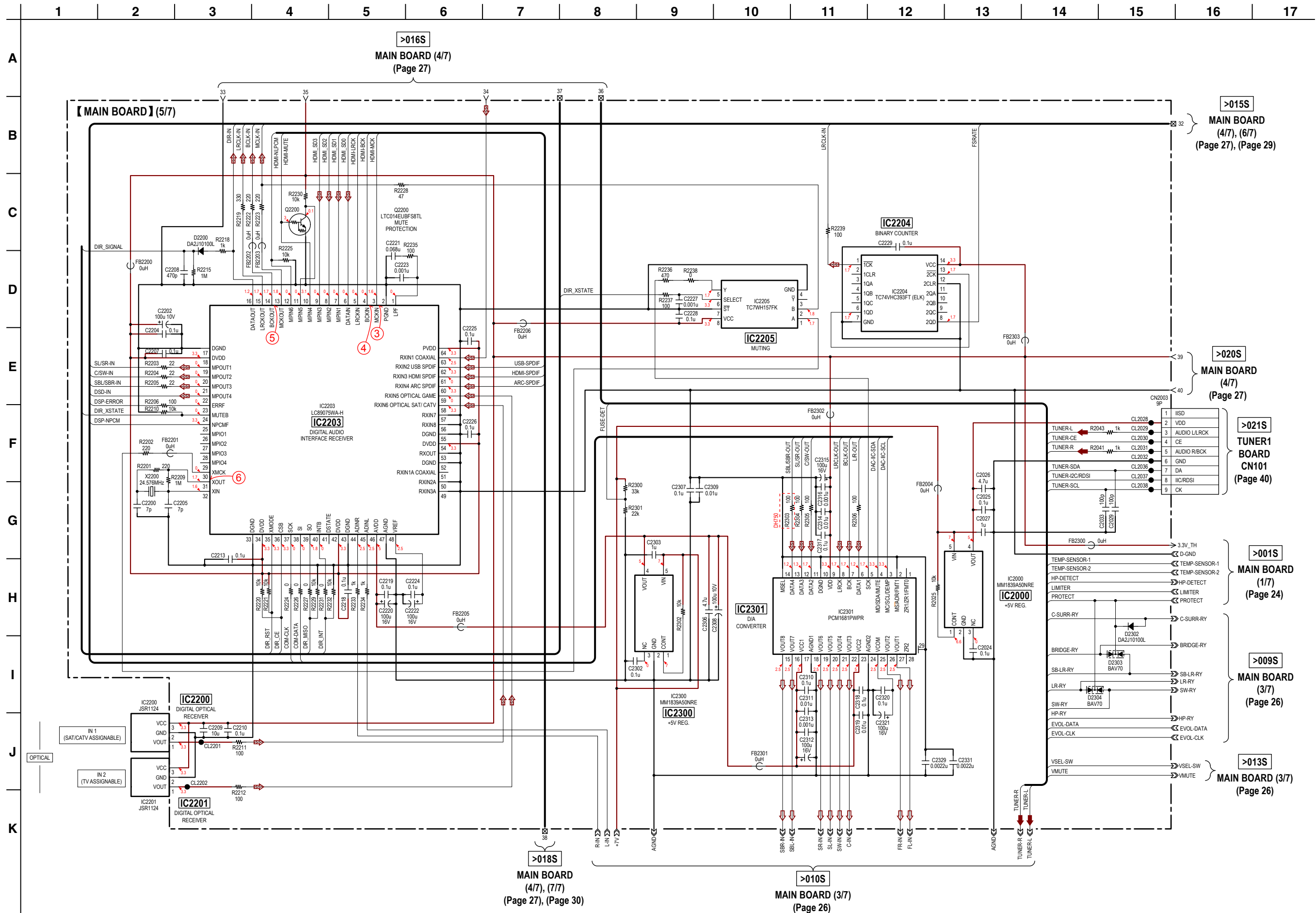

5-14. SCHEMATIC DIAGRAM – MAIN Board (6/7) – • See page 21 for Waveforms.

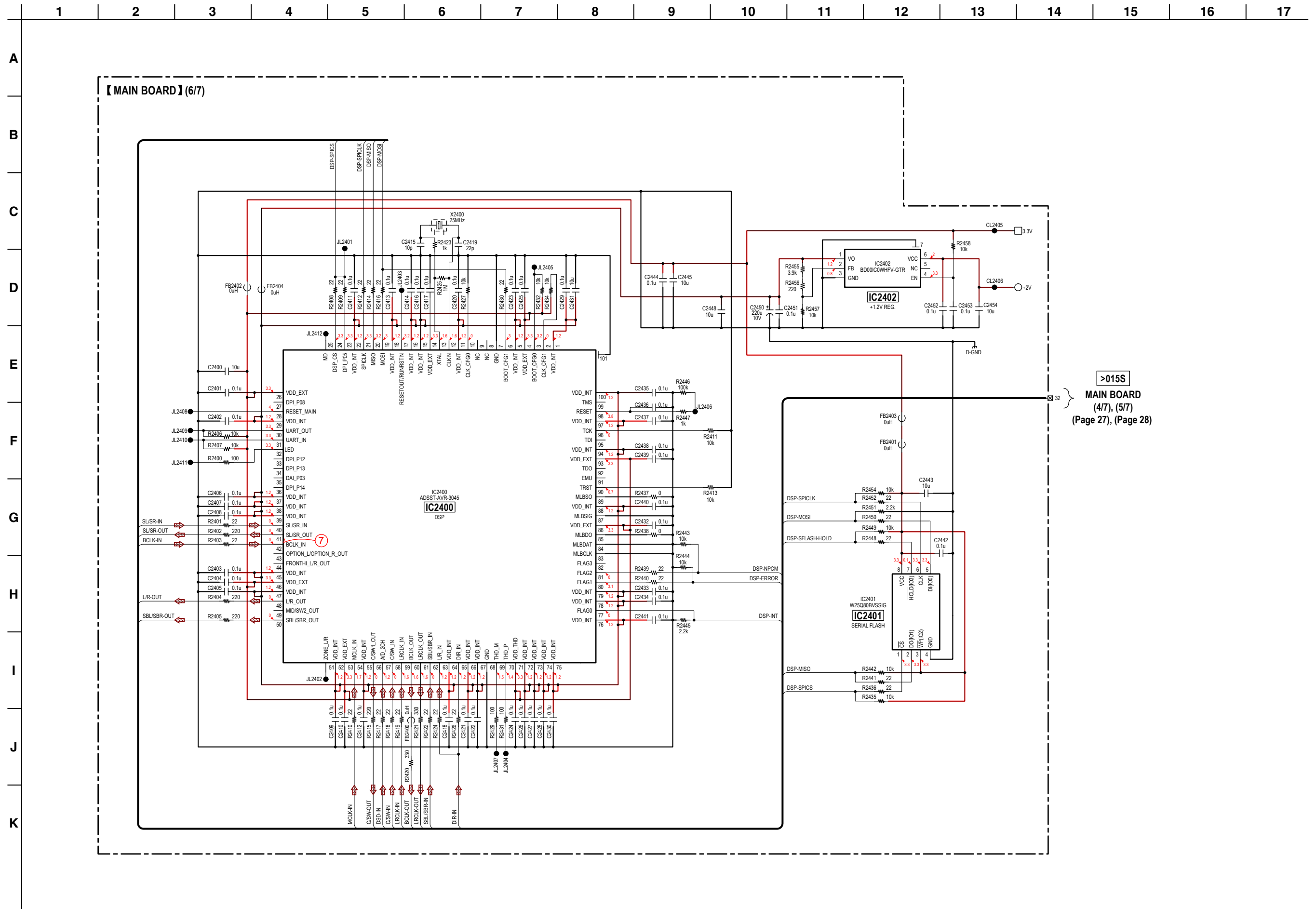

>015S
 MAIN BOARD
 (4/7), (5/7)
 (Page 27), (Page 28)

Note: IC2402 on the MAIN board cannot exchange with single. When this part on the MAIN board is damaged, exchange the entire mounted board.

5-15. SCHEMATIC DIAGRAM – MAIN Board (7/7) – • See page 21 for Waveforms. • See page 43 for IC Block Diagrams. • See page 50 for IC Pin Function Descriptions.

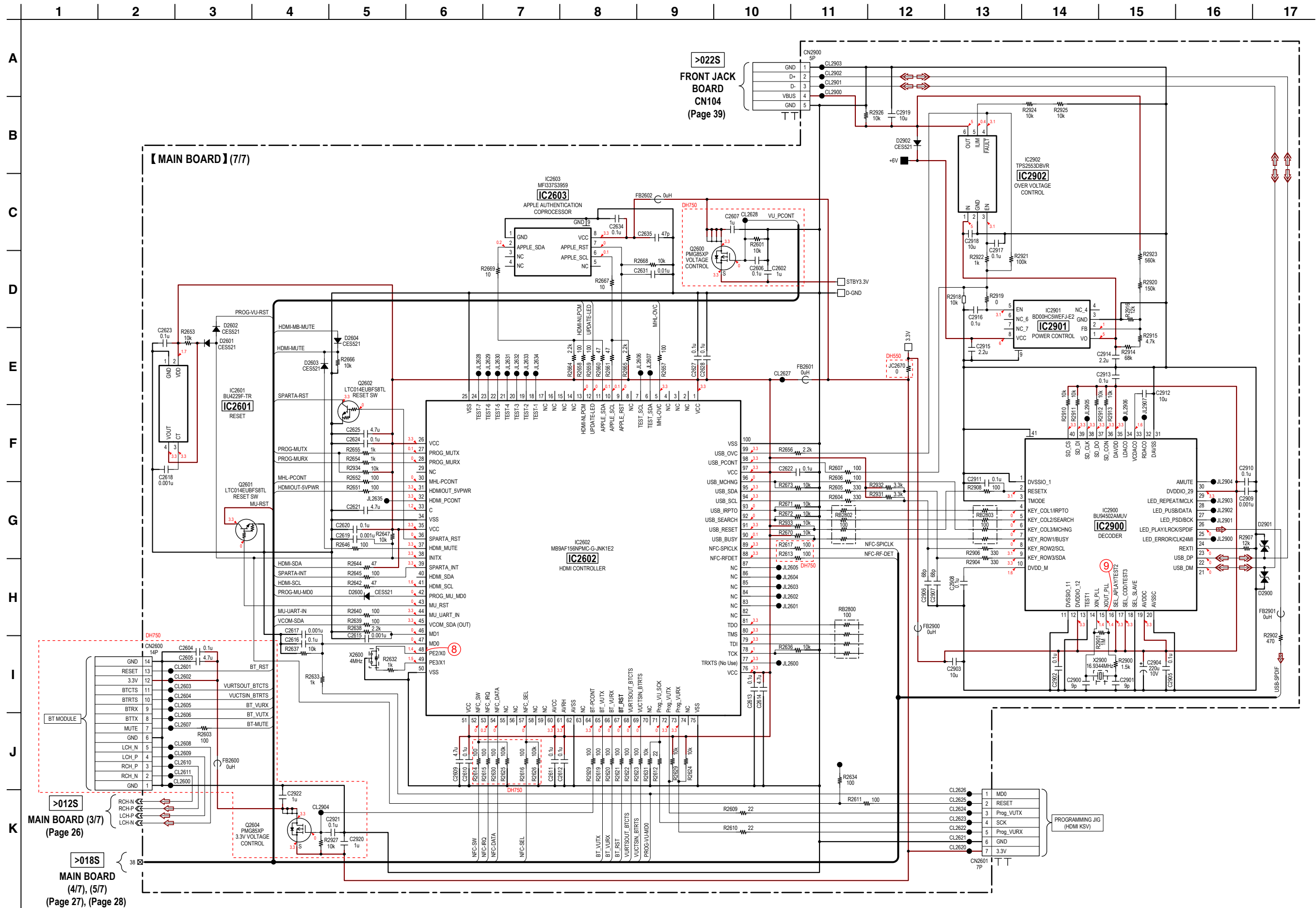

5-17. PRINTED WIRING BOARD – HDMI Board (Conductor Side) – • See page 14 for Circuit Boards Location. • : Uses unleaded solder.

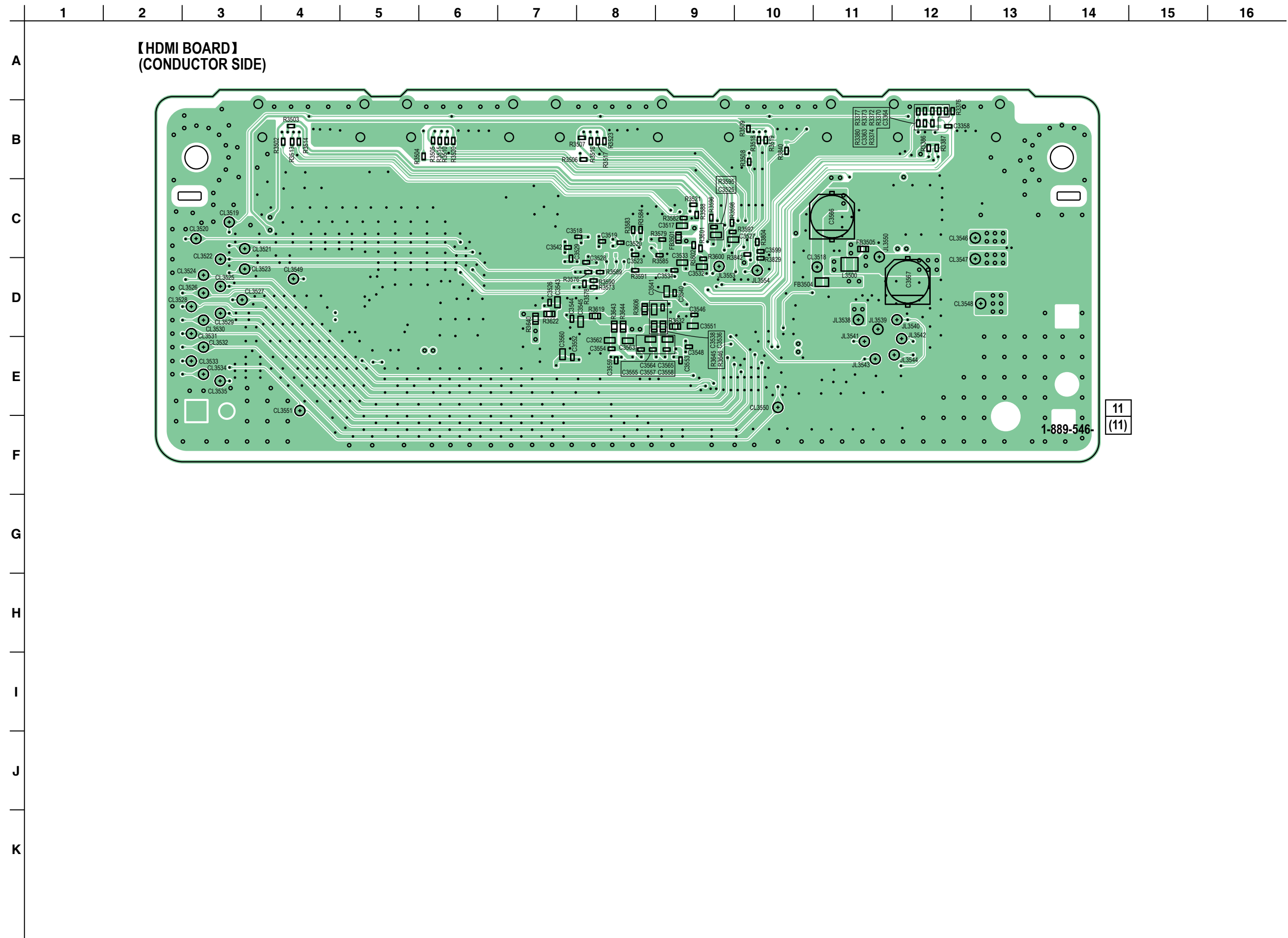

5-19. PRINTED WIRING BOARD – STANDBY DCDC Board (Component Side) – • See page 14 for Circuit Boards Location. • : Uses unleaded solder.

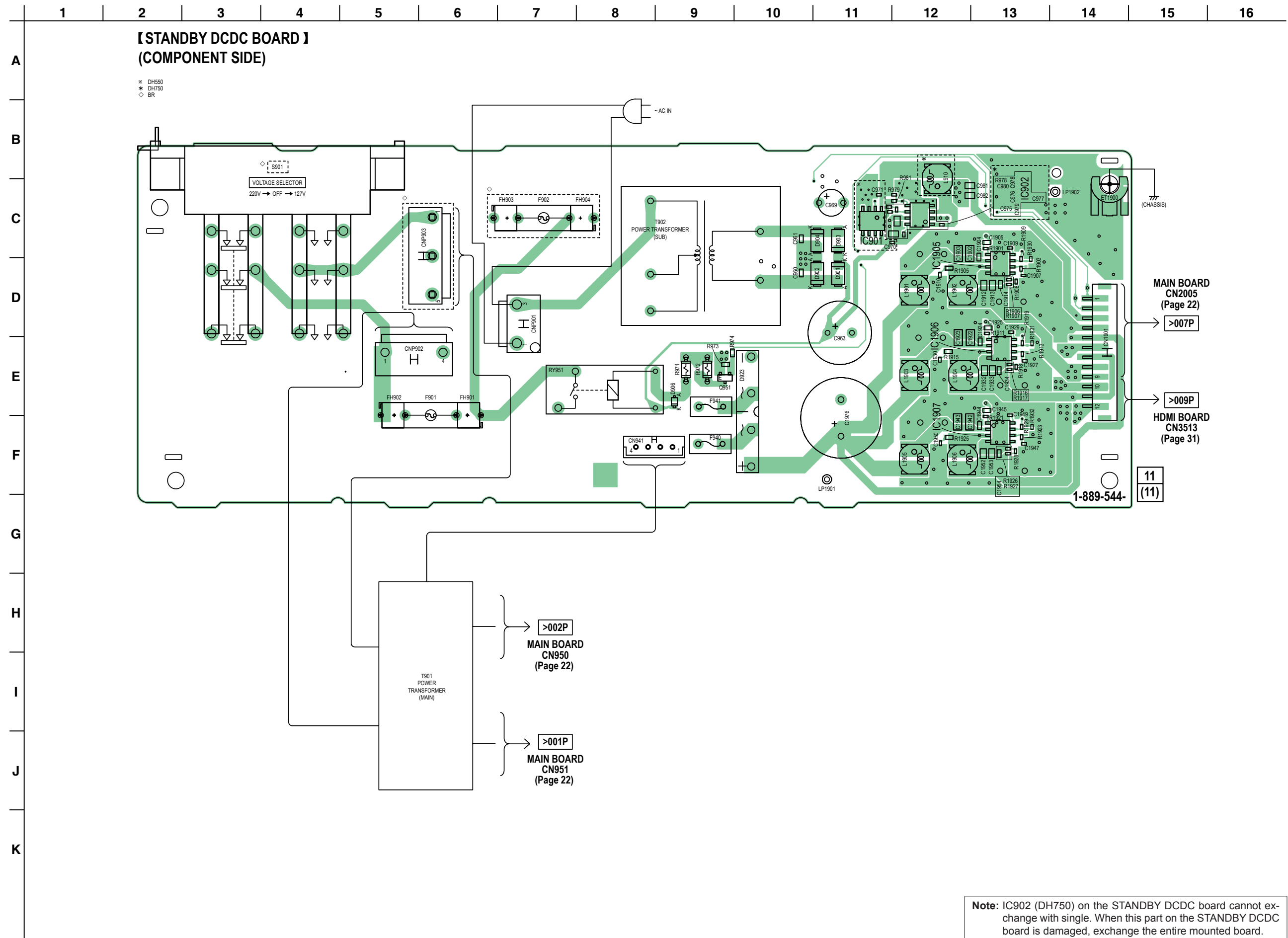

5-20. PRINTED WIRING BOARD – STANDBY DCDC Board (Conductor Side) – • See page 14 for Circuit Boards Location. • : Uses unleaded solder.

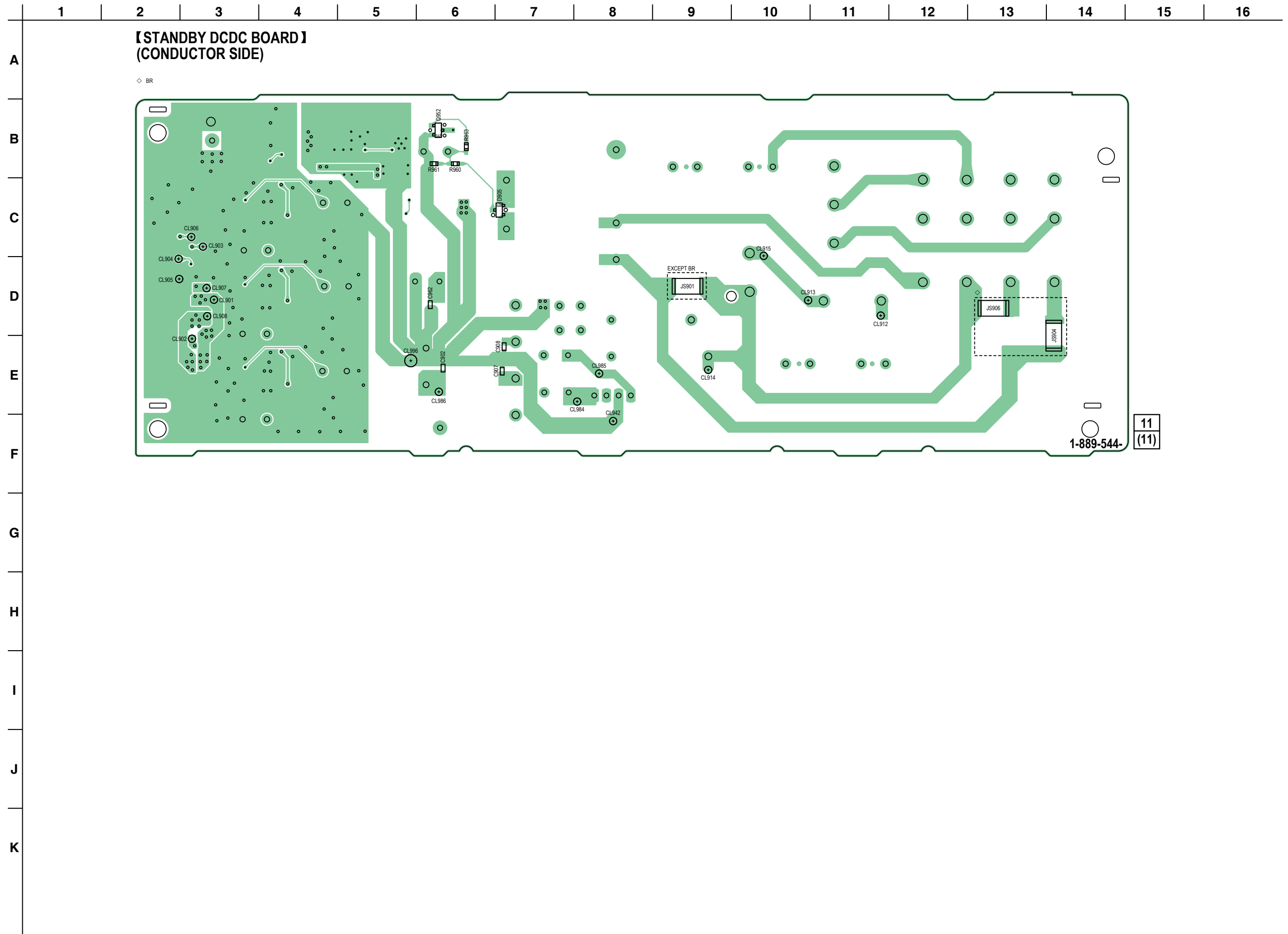

5-21. SCHEMATIC DIAGRAM – STANDBY DCDC Board –

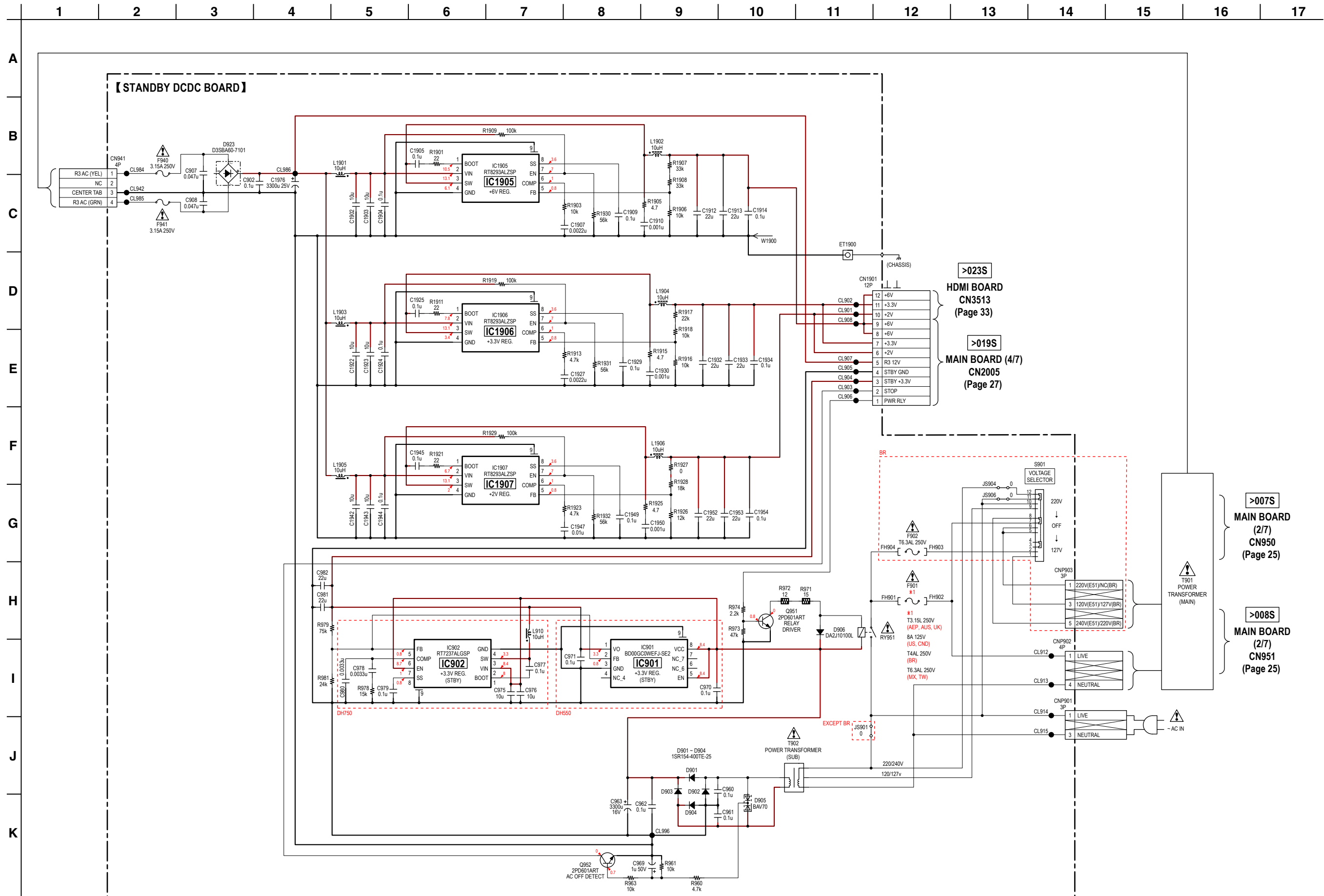

Note: IC902 (DH750) on the STANDBY DCDC board cannot exchange with single. When this part on the STANDBY DCDC board is damaged, exchange the entire mounted board.

5-22. PRINTED WIRING BOARD – PANEL Section – • See page 14 for Circuit Boards Location. • : Uses unleaded solder.

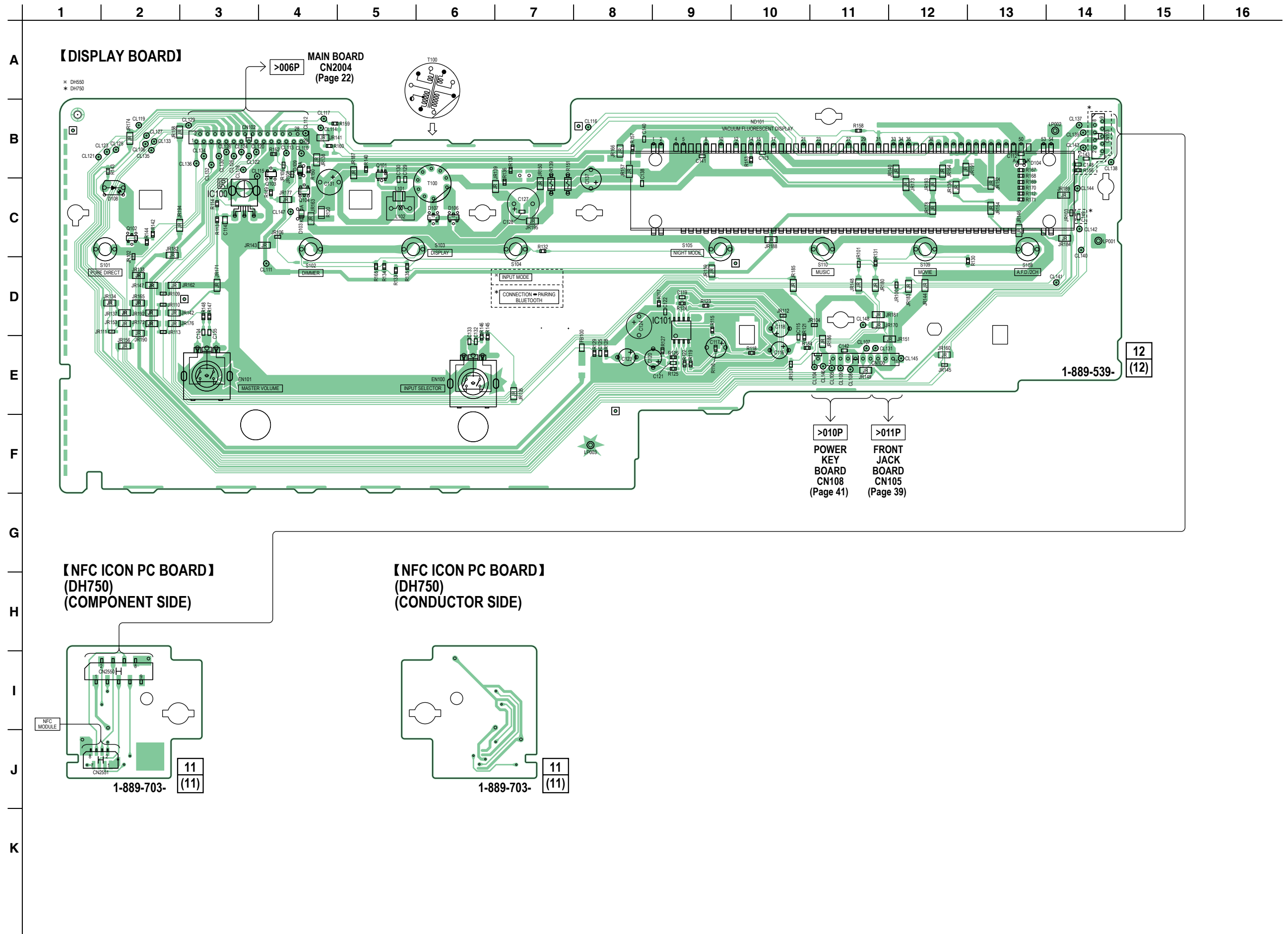

5-23. SCHEMATIC DIAGRAM – PANEL Section –

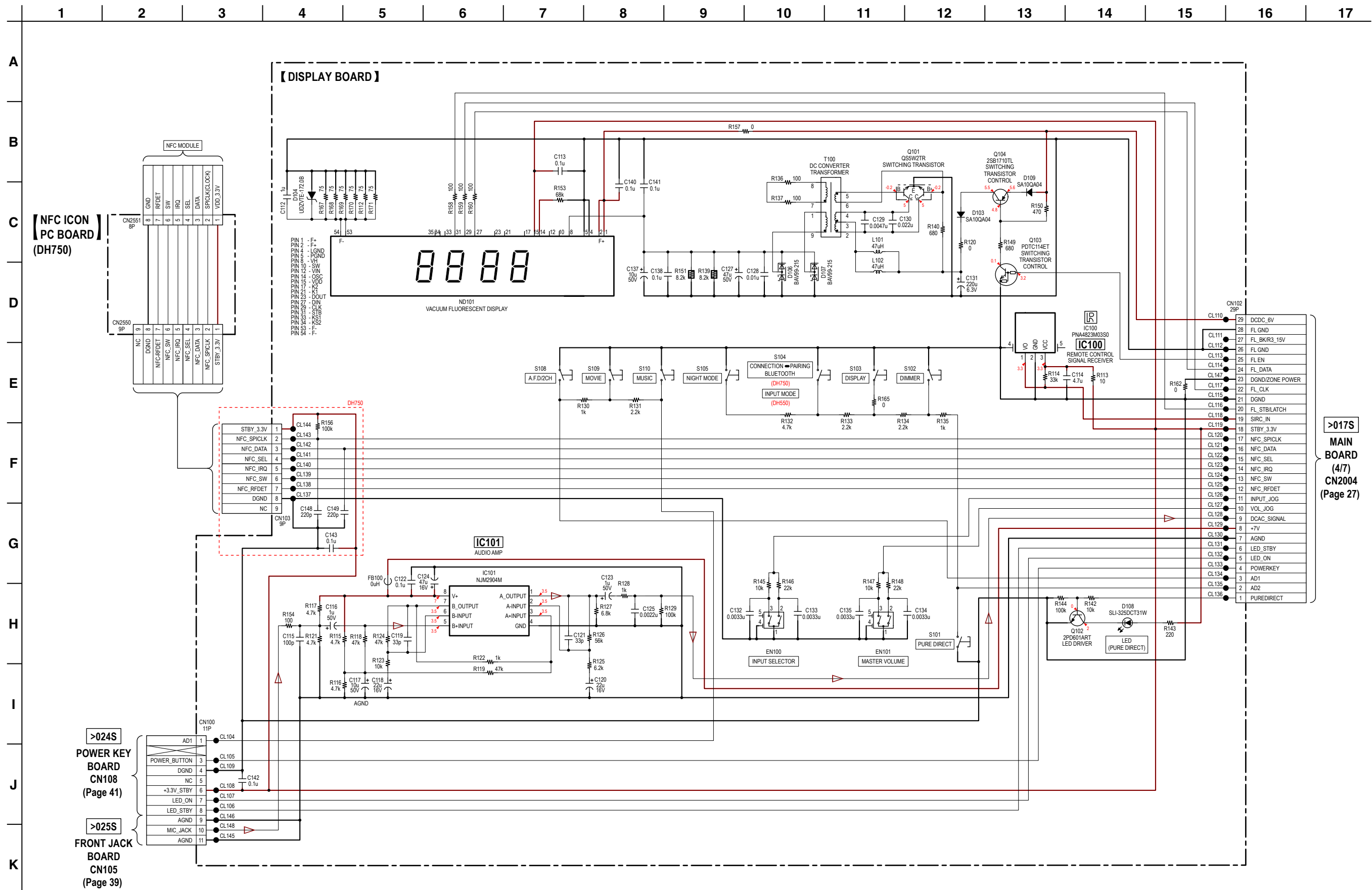

>017S
MAIN BOARD (4/7)
CN2004 (Page 27)

5-24. PRINTED WIRING BOARD – FRONT JACK Board –

• See page 14 for Circuit Boards Location. • : Uses unleaded solder.

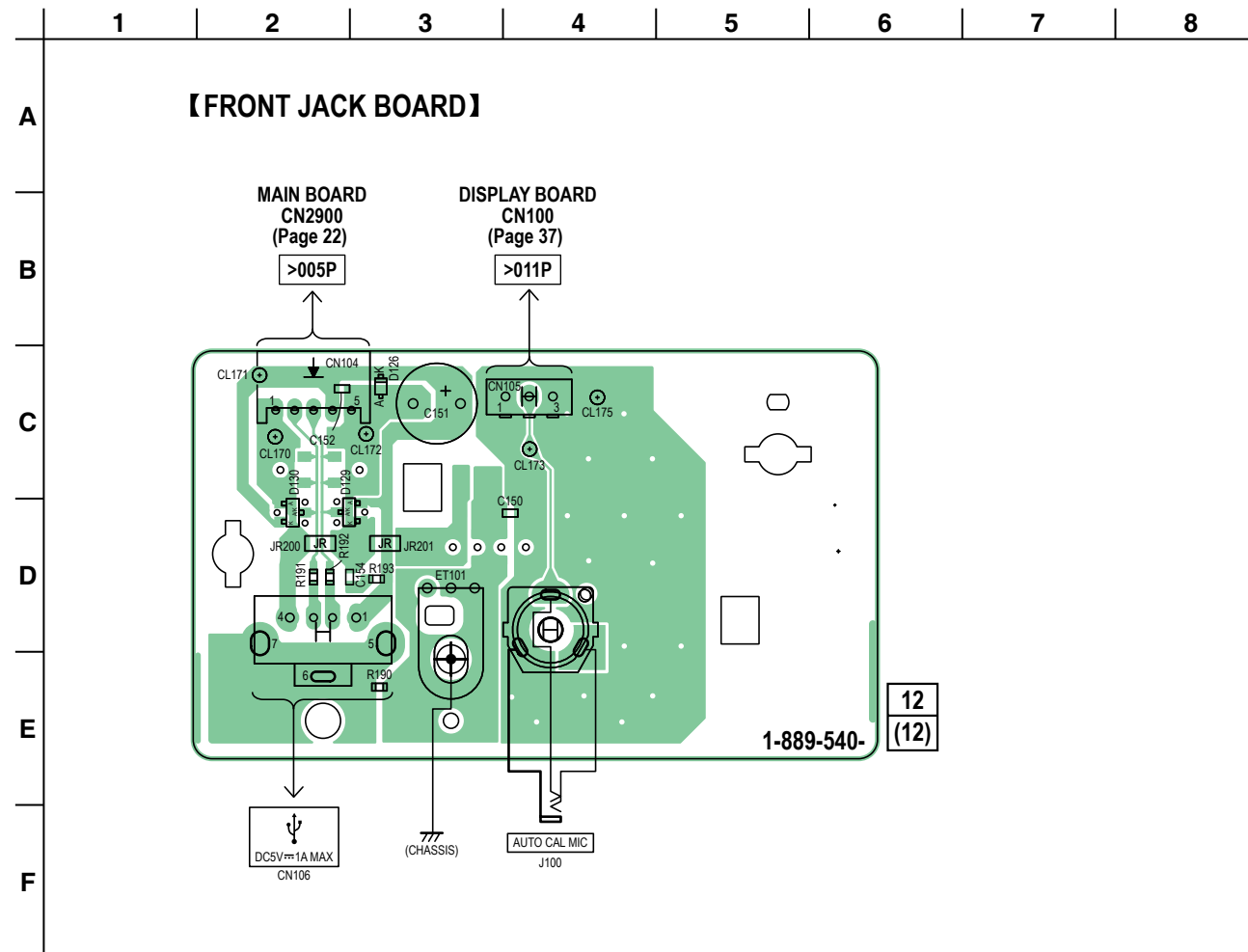

5-25. SCHEMATIC DIAGRAM – FRONT JACK Board –

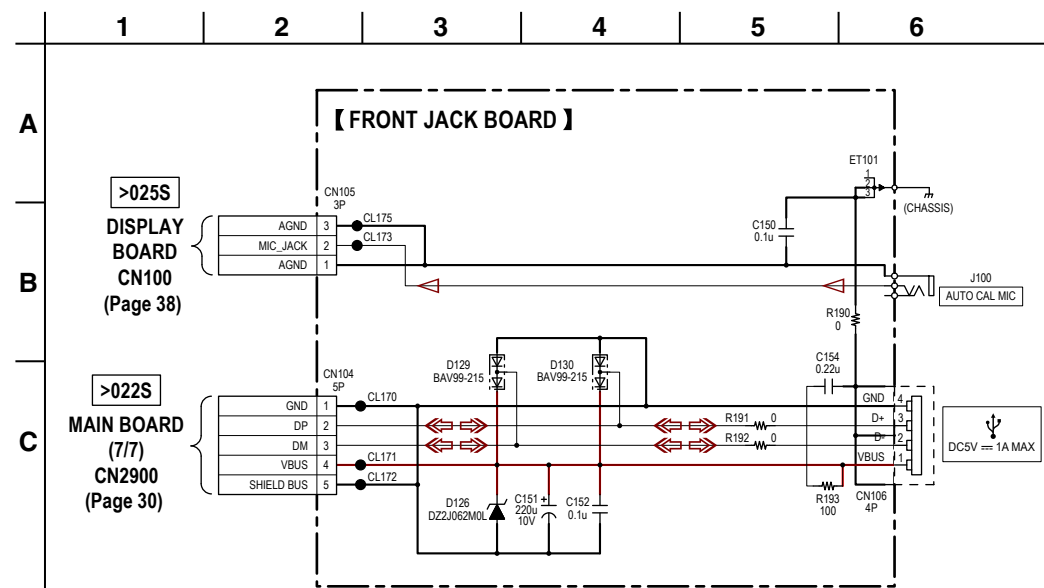

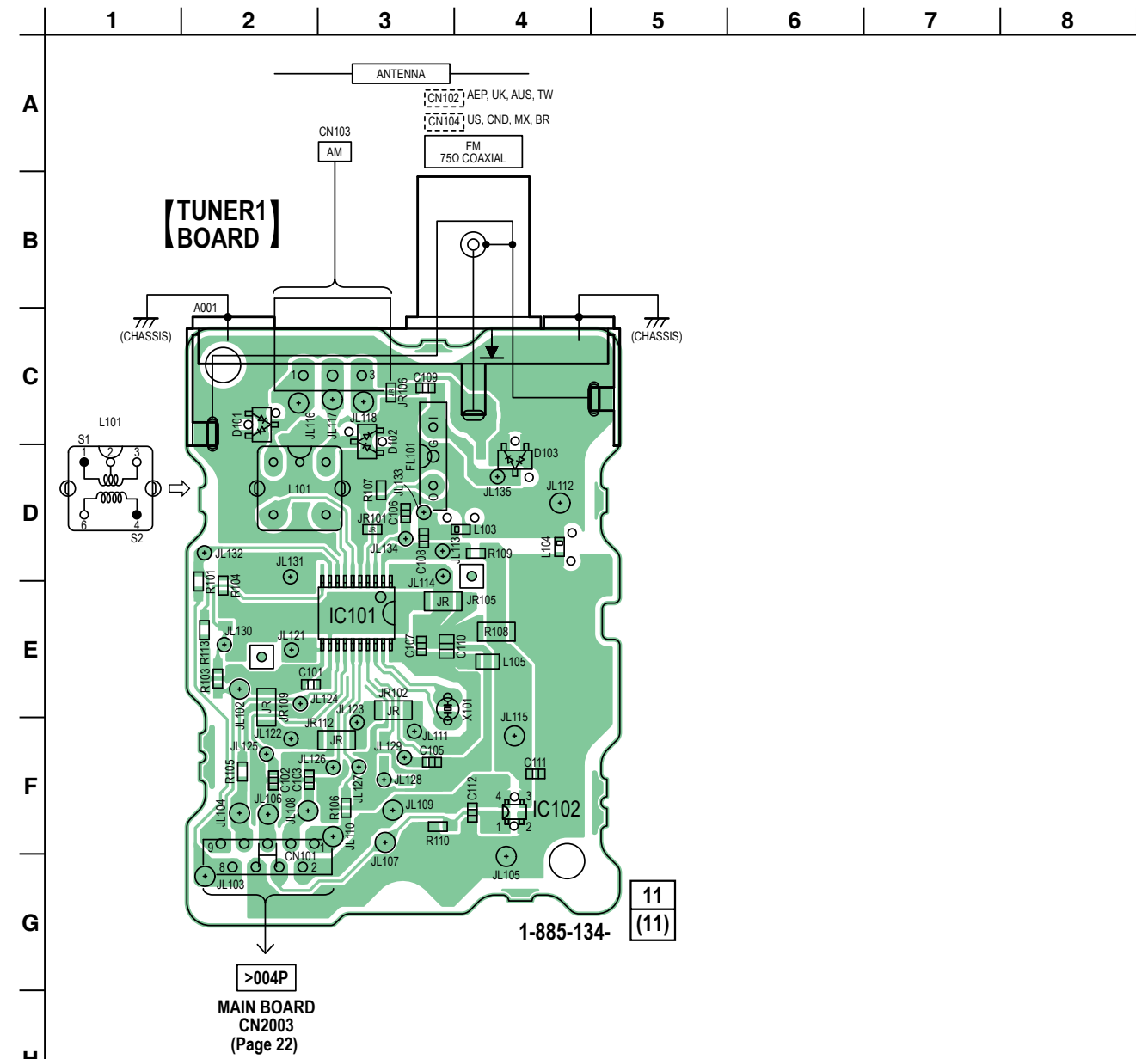

5-26. PRINTED WIRING BOARD – TUNER1 Board –

• See page 14 for Circuit Boards Location. • : Uses unleaded solder.

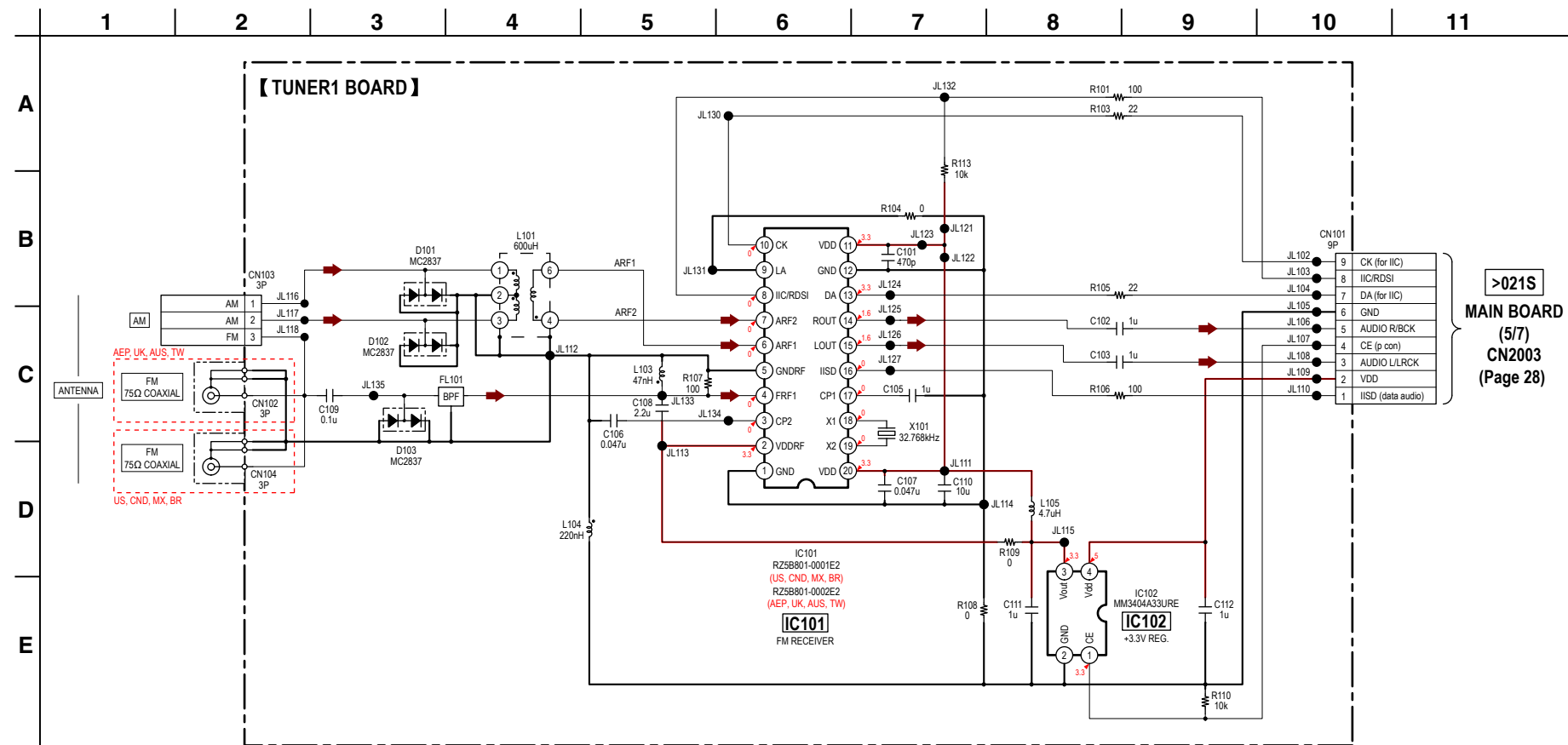

5-27. SCHEMATIC DIAGRAM – TUNER1 Board – • See page 43 for IC Block Diagrams.



5-28. PRINTED WIRING BOARD – POWER KEY Board –
 • See page 14 for Circuit Boards Location. • : Uses unleaded solder.

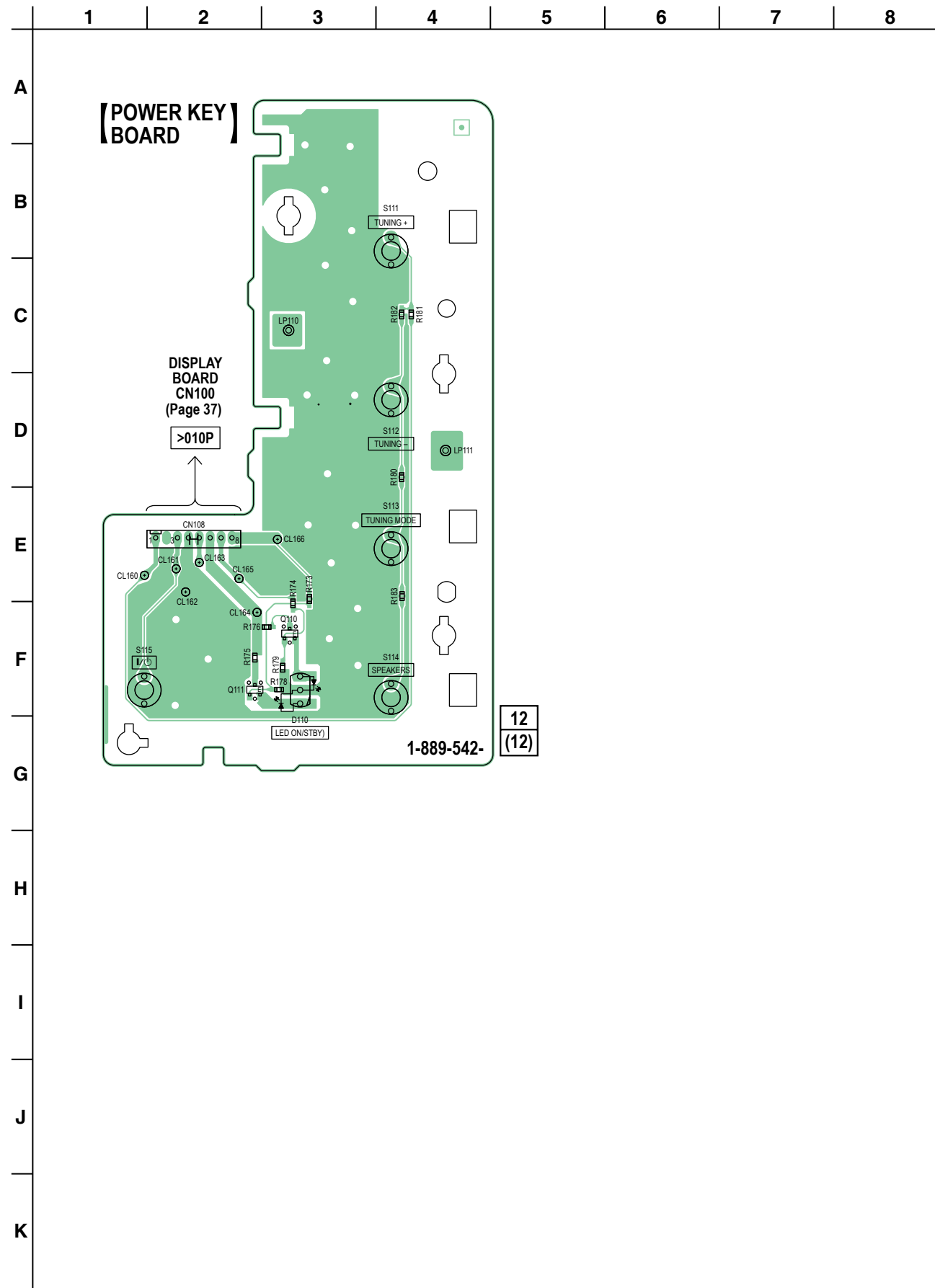

5-29. SCHEMATIC DIAGRAM – POWER KEY Board –

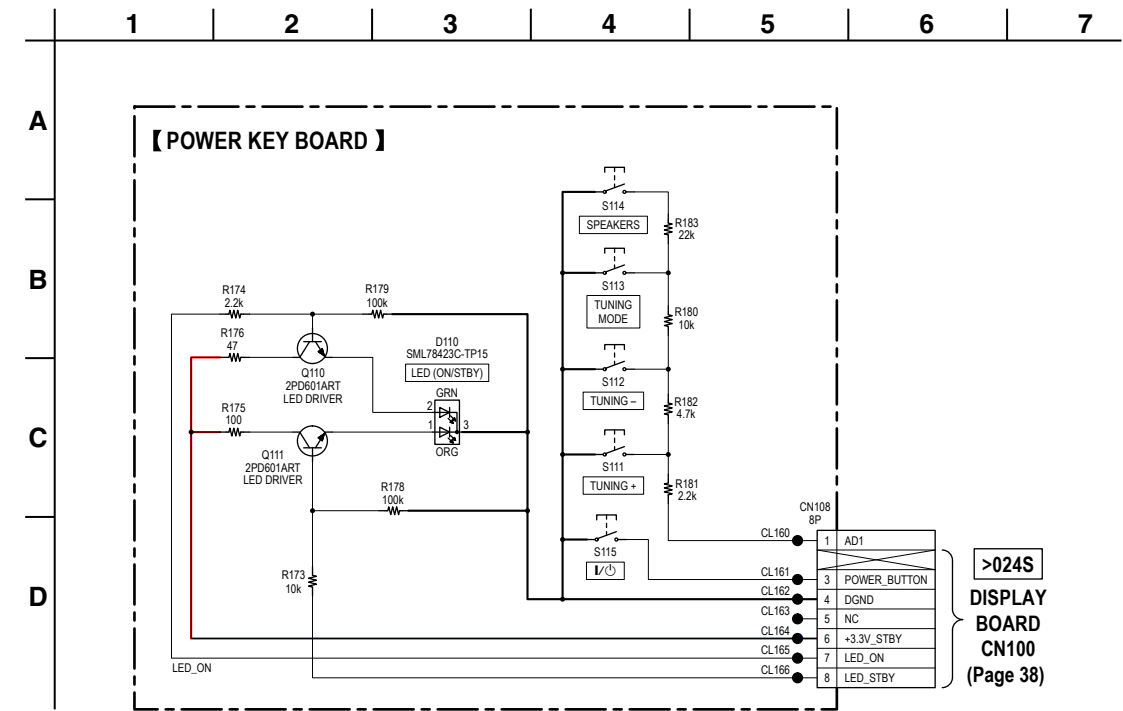

5-30. PRINTED WIRING BOARD – HEADPHONE Board –

• See page 14 for Circuit Boards Location. • : Uses unleaded solder.

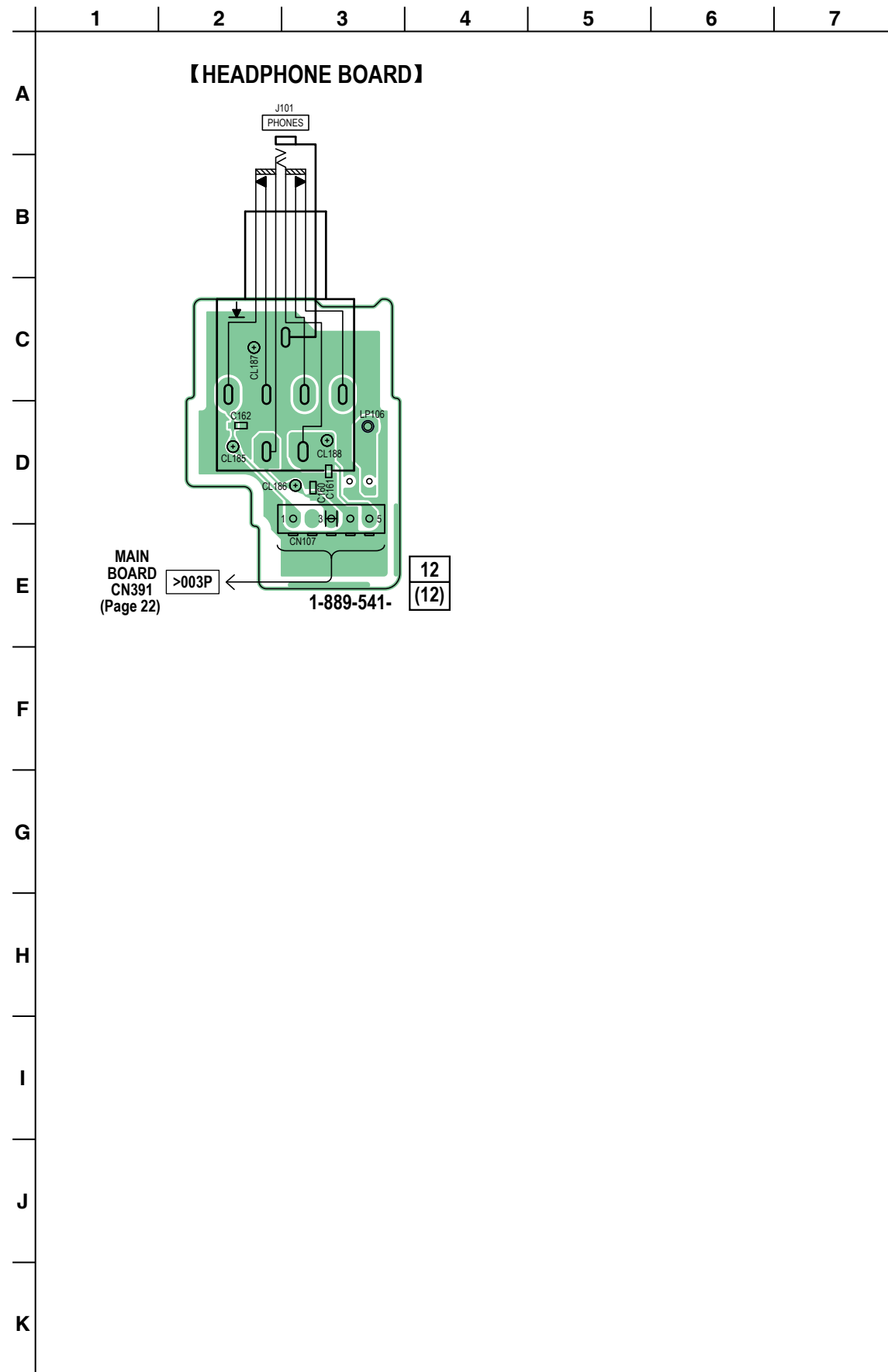

5-31. SCHEMATIC DIAGRAM – HEADPHONE Board –

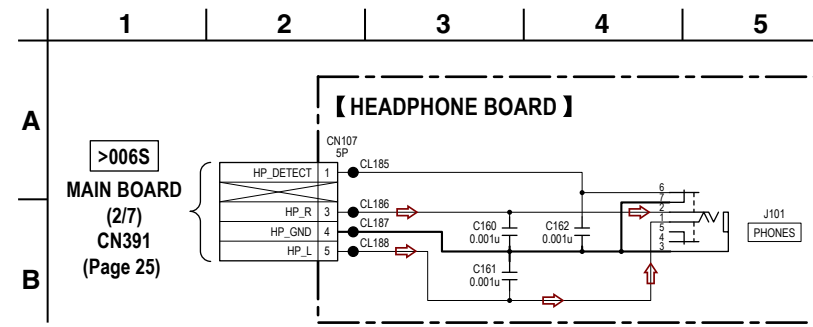

• IC Block Diagrams

IC3518 TPS2553DBVR (HDMI BOARD)

IC2902 TPS2553DBVR (MAIN BOARD (7/7))

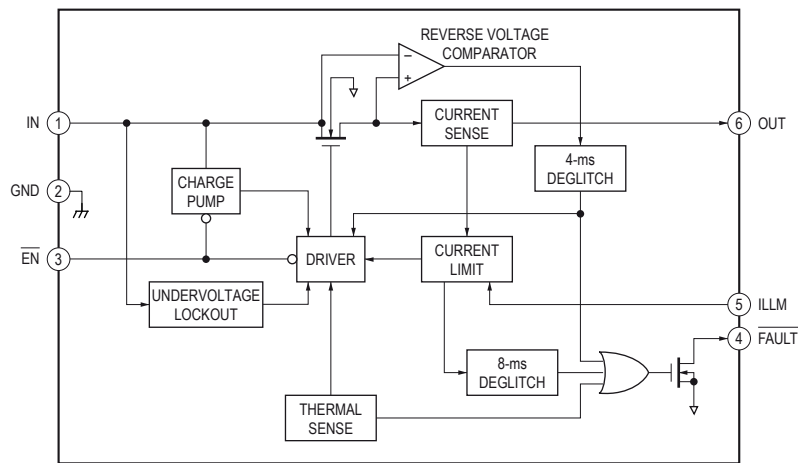

IC200 NJM41010F1 (MAIN BOARD (3/7))

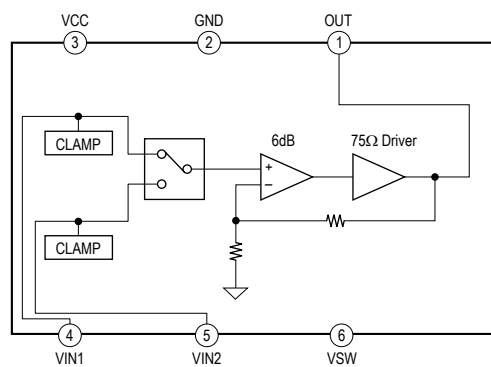

IC400 BD34701KS2 (MAIN BOARD (3/7))

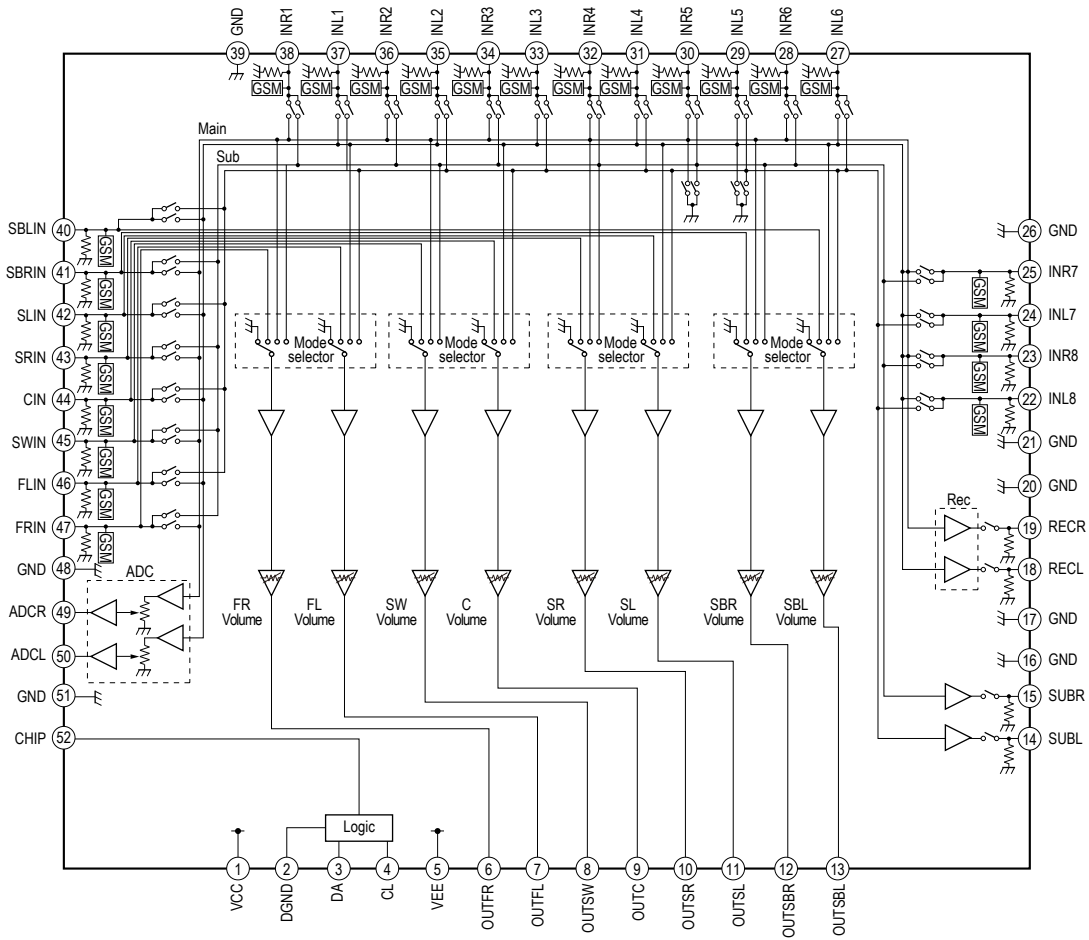

IC2008 BR24T64FJ-WE2 (MAIN BOARD (4/7))

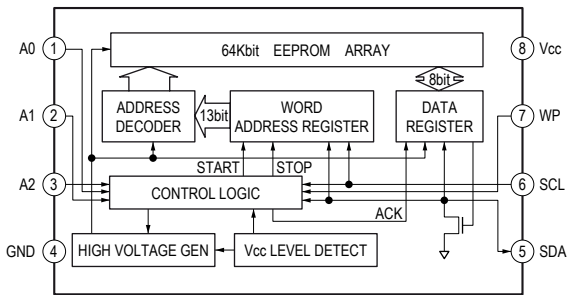

IC2009 BU4229F-TR (MAIN BOARD (4/7))
 IC2601 BU4229F-TR (MAIN BOARD (7/7))

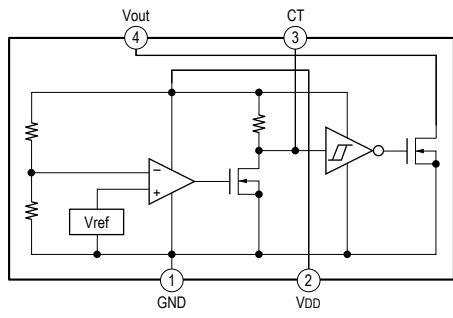

IC2202 TC7WHU04FK (MAIN BOARD (4/7))

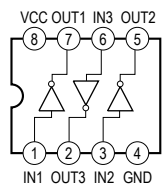

STR-DH550/DH750

IC2203 LC89075WA-H (MAIN BOARD (5/7))

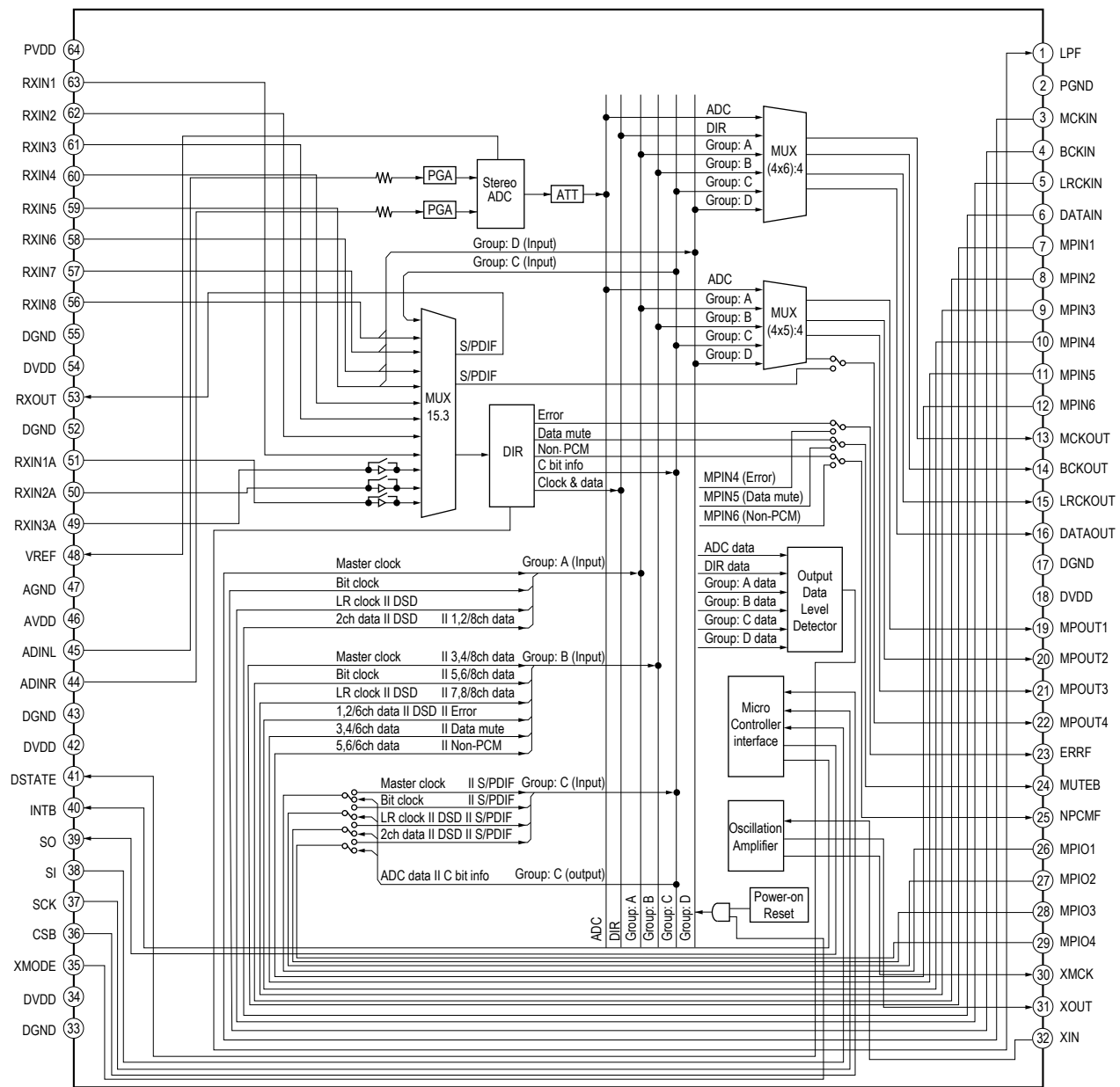

IC2204 TC74VHC393FT (ELK) (MAIN BOARD (5/7))

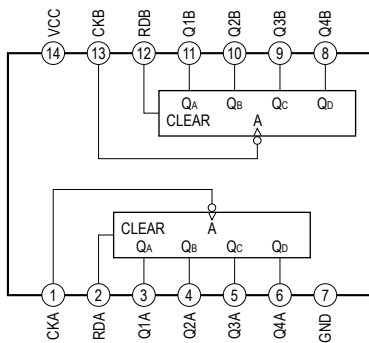

IC2205 TC7WH157FK (MAIN BOARD (5/7))

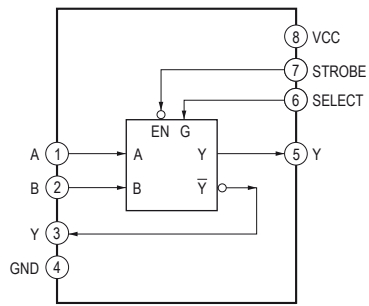

IC2301 PCM1681PWPR (MAIN BOARD (5/7))

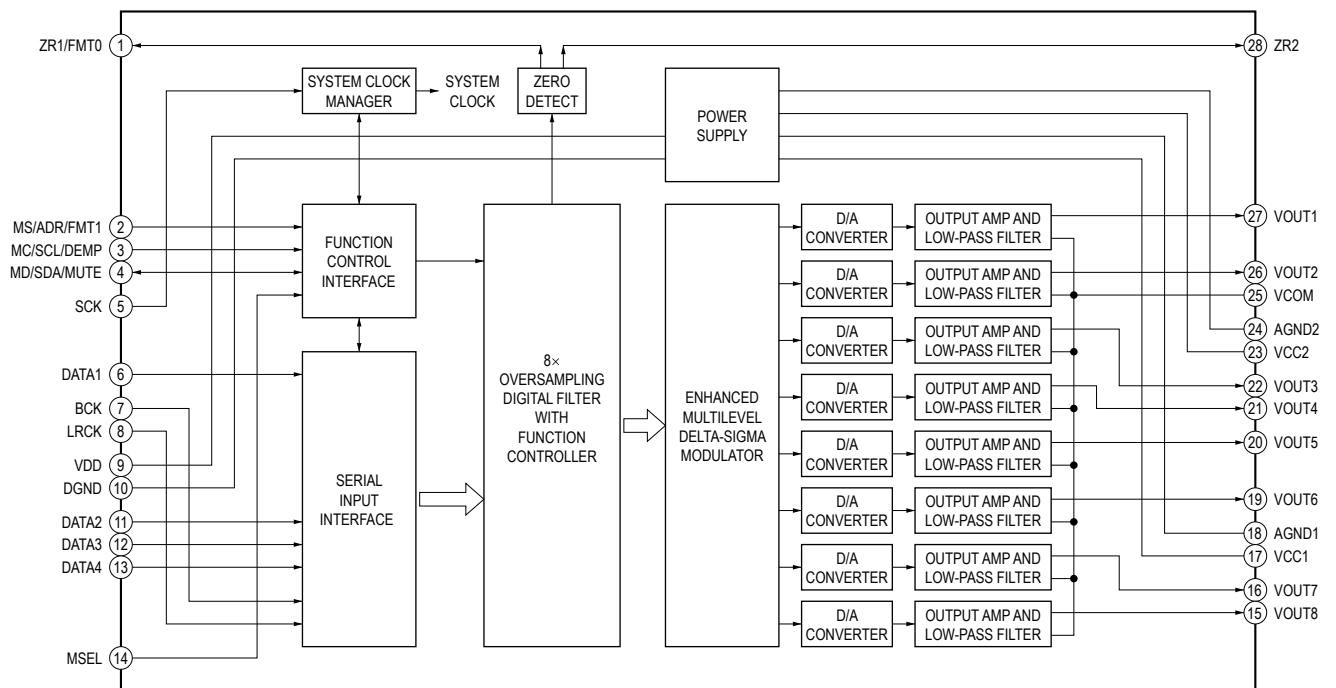

IC2900 BU94502AMUV (MAIN BOARD (7/7))

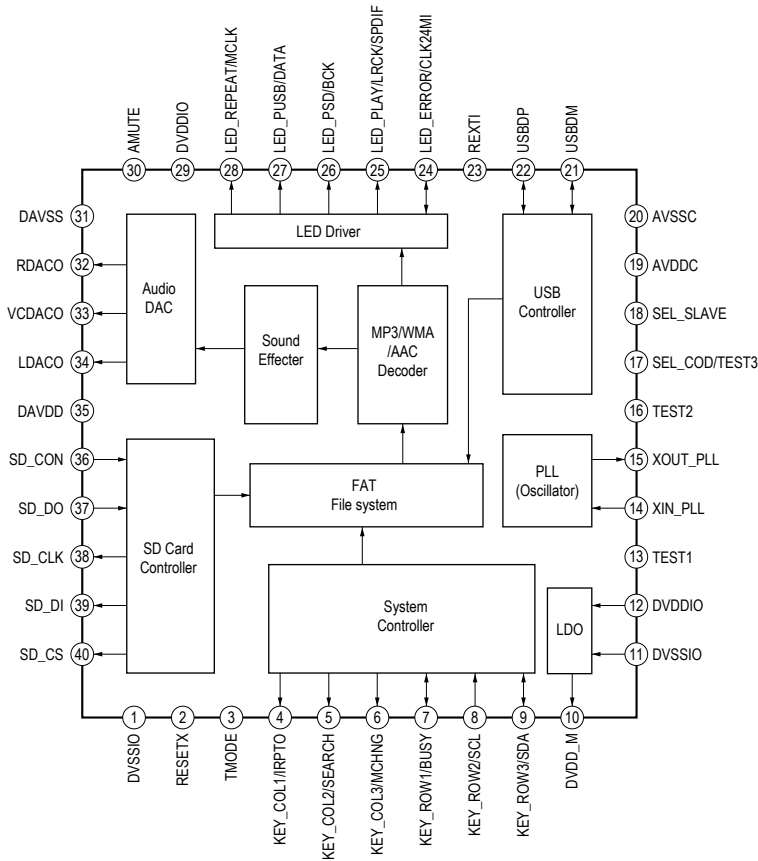

IC101 RZ5B801-0001E2 (TUNER1 BOARD) (US, Canadian, Mexican and Brazillian models)

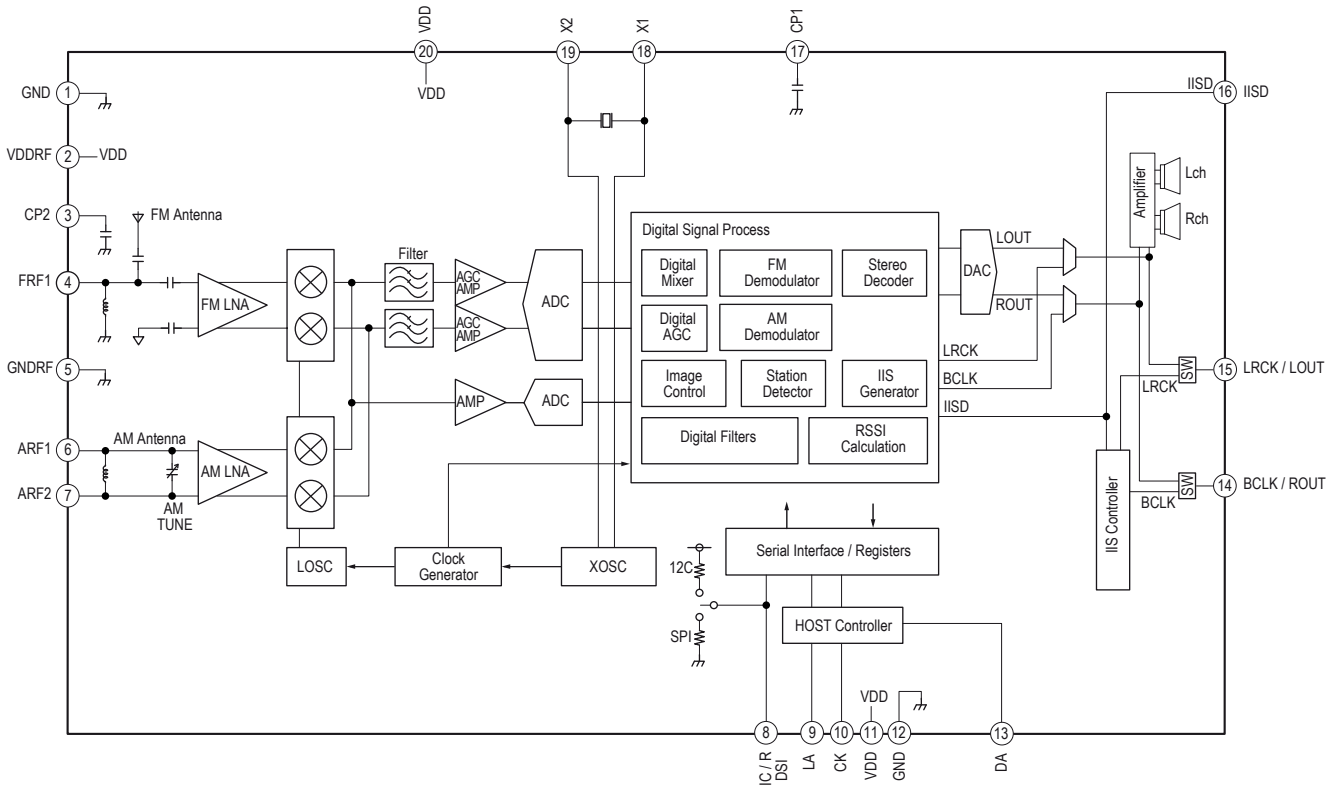

IC101 RZ5B801-0002E2 (TUNER1 BOARD) (AEP, UK, Australian and Taiwan models)

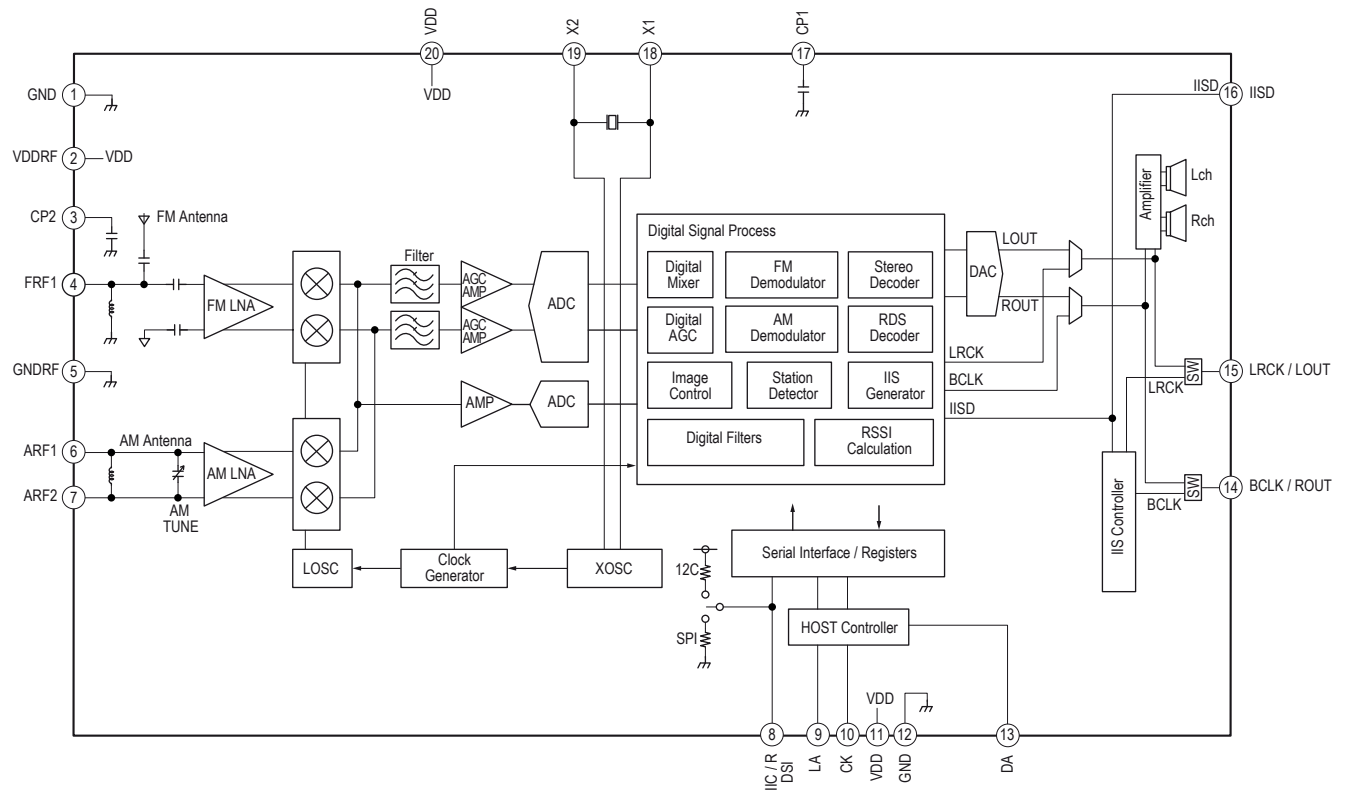

• IC Pin Function Descriptions

HDMI BOARD IC3514 SII9573CTUC (HDMI RECEIVER)

Pin No.	Pin Name	I/O	Description
1 to 6	D14 to D19	I	Digital video signal input from the video deinterlacing
7	DE	I	Data enable signal input from the video deinterlacing
8	VSYNC	O	Vertical sync signal input from the video deinterlacing
9	HSYNC	O	Horizontal sync signal input from the video deinterlacing
10	R0XC-	I	TMDS clock (negative) signal input from the HDMI IN connector Not used
11	R0XC+	I	TMDS clock (positive) signal input from the HDMI IN connector Not used
12	R0X0-	I	TMDS data (negative) input from the HDMI IN connector Not used
13	R0X0+	I	TMDS data (positive) input from the HDMI IN connector Not used
14	R0X1-	I	TMDS data (negative) input from the HDMI IN connector Not used
15	R0X1+	I	TMDS data (positive) input from the HDMI IN connector Not used
16	R0X2-	I	TMDS data (negative) input from the HDMI IN connector Not used
17	R0X2+	I	TMDS data (positive) input from the HDMI IN connector Not used
18	AVDD12	-	Power supply terminal (+1.2V)
19	AVDD33	-	Power supply terminal (+3.3V)
20	R1XC-	I	TMDS clock (negative) signal input from the HDMI IN connector Not used
21	R1XC+	I	TMDS clock (positive) signal input from the HDMI IN connector Not used
22	R1X0-	I	TMDS data (negative) input from the HDMI IN connector Not used
23	R1X0+	I	TMDS data (positive) input from the HDMI IN connector Not used
24	R1X1-	I	TMDS data (negative) input from the HDMI IN connector Not used
25	R1X1+	I	TMDS data (positive) input from the HDMI IN connector Not used
26	R1X2-	I	TMDS data (negative) input from the HDMI IN connector Not used
27	R1X2+	I	TMDS data (positive) input from the HDMI IN connector Not used
28	R2XC-	I	TMDS clock (negative) signal input from the HDMI IN (BD) connector
29	R2XC+	I	TMDS clock (positive) signal input from the HDMI IN (BD) connector
30	R2X0-	I	TMDS data (negative) input from the HDMI IN (BD) connector
31	R2X0+	I	TMDS data (positive) input from the HDMI IN (BD) connector
32	R2X1-	I	TMDS data (negative) input from the HDMI IN (BD) connector
33	R2X1+	I	TMDS data (positive) input from the HDMI IN (BD) connector
34	R2X2-	I	TMDS data (negative) input from the HDMI IN (BD) connector
35	R2X2+	I	TMDS data (positive) input from the HDMI IN (BD) connector
36	AVDD12	-	Power supply terminal (+1.2V)
37	CVDD12	-	Power supply terminal (+1.2V)
38	AVDD33	-	Power supply terminal (+3.3V)
39	R3XC-	I	TMDS clock (negative) signal input from the HDMI IN (DVD) connector
40	R3XC+	I	TMDS clock (positive) signal input from the HDMI IN (DVD) connector
41	R3X0-	I	TMDS data (negative) input from the HDMI IN (DVD) connector
42	R3X0+	I	TMDS data (positive) input from the HDMI IN (DVD) connector
43	R3X1-	I	TMDS data (negative) input from the HDMI IN (DVD) connector
44	R3X1+	I	TMDS data (positive) input from the HDMI IN (DVD) connector
45	R3X2-	I	TMDS data (negative) input from the HDMI IN (DVD) connector
46	R3X2+	I	TMDS data (positive) input from the HDMI IN (DVD) connector
47	R4XC-	I	TMDS clock (negative) signal input from the HDMI IN (GAME) connector
48	R4XC+	I	TMDS clock (positive) signal input from the HDMI IN (GAME) connector
49	R4X0-	I	TMDS data (negative) input from the HDMI IN (GAME) connector
50	R4X0+	I	TMDS data (positive) input from the HDMI IN (GAME) connector
51	R4X1-	I	TMDS data (negative) input from the HDMI IN (GAME) connector
52	R4X1+	I	TMDS data (positive) input from the HDMI IN (GAME) connector
53	R4X2-	I	TMDS data (negative) input from the HDMI IN (GAME) connector
54	R4X2+	I	TMDS data (positive) input from the HDMI IN (GAME) connector
55	CVDD12	-	Power supply terminal (+1.2V)
56	AVDD33	-	Power supply terminal (+3.3V)
57	R5XC-	I	TMDS clock (negative) signal input from the HDMI IN (SAT/CATV) connector
58	R5XC+	I	TMDS clock (positive) signal input from the HDMI IN (SAT/CATV) connector
59	R5X0-	I	TMDS data (negative) input from the HDMI IN (SAT/CATV) connector

Pin No.	Pin Name	I/O	Description
60	R5X0+	I	TMDS data (positive) input from the HDMI IN (SAT/CATV) connector
61	R5X1-	I	TMDS data (negative) input from the HDMI IN (SAT/CATV) connector
62	R5X1+	I	TMDS data (positive) input from the HDMI IN (SAT/CATV) connector
63	R5X2-	I	TMDS data (negative) input from the HDMI IN (SAT/CATV) connector
64	R5X2+	I	TMDS data (positive) input from the HDMI IN (SAT/CATV) connector
65	CVCC12	-	Power supply terminal (+1.2V)
66	CSCL	I/O	Two-way I2C clock bus with the video system controller
67	CSDA	I/O	Two-way I2C data bus with the video system controller
68	INT	O	Interrupt signal output to the video system controller
69	RESET	I	Reset signal input from the video system controller "L": reset
70	TPWR_CI2CS	I	Not used
71	CEC_A1	O	Not used
72	CEC_A0WAKEUP	O	Not used
73	DSDA6	I/O	Two-way I2C serial data bus terminal Not used
74	DSCL6	I	I2C serial data transfer clock signal input terminal Not used
75	LPSVCC33	I	Not used
76	DSDA0	I/O	Two-way I2C serial data bus with the HDMI IN connector Not used
77	DSCL0	I	I2C serial data transfer clock signal input from the HDMI IN connector Not used
78	CBUS_HPDP0	O	Hot plug detection control signal output to the HDMI IN connector Not used
79	R0PWR5V	I	Power supply voltage (+5V) input terminal
80	DSDA1	I/O	Two-way I2C serial data bus with the HDMI IN connector Not used
81	DSCL1	I	I2C serial data transfer clock signal input from the HDMI IN connector Not used
82	CBUS_HPDP1	O	Hot plug detection control signal output to the HDMI IN connector Not used
83	R1PWR5V	I	Power supply voltage (+5V) input terminal
84	DSDA2	I/O	Two-way I2C serial data bus with the HDMI IN (BD) connector
85	DSCL2	I	I2C serial data transfer clock signal input from the HDMI IN (BD) connector
86	CBUS_HPDP2	O	Hot plug detection control signal output to the HDMI IN (BD) connector
87	R2PWR5V	I	Power supply voltage (+5V) input terminal
88	DSDA3	I/O	Two-way I2C serial data bus with the HDMI IN (DVD) connector
89	DSCL3	I	I2C serial data transfer clock signal input from the HDMI IN (DVD) connector
90	CBUS_HPDP3	O	Hot plug detection control signal output to the HDMI IN (DVD) connector
91	R3PWR5V	I	Power supply voltage (+5V) input terminal
92	DSDA4	I/O	Two-way I2C serial data bus with the HDMI IN (GAME) connector
93	DSCL4	I	I2C serial data transfer clock signal input from the HDMI IN (GAME) connector
94	CBUS_HPDP4	O	Hot plug detection control signal output to the HDMI IN (GAME) connector
95	R4PWR5V	I	Power supply voltage (+5V) input terminal
96	RSVDL	I	Not used
97	DSDA5	I/O	Two-way I2C serial data bus with the HDMI IN (SAT/CATV) connector
98	DSCL5	I	I2C serial data transfer clock signal input from the HDMI IN (SAT/CATV) connector
99	CBUS_HPDP5	O	Hot plug detection control signal output to the HDMI IN (SAT/CATV) connector
100	R4PWR5V	I	Power supply voltage (+5V) input terminal
101	SBVCC5V	-	Power supply terminal (+1.2V)
102	VCC33OUT	O	Power supply (+3.3V) output terminal
103, 104	GPIO0, GPIO1	I/O	Not used
105	TX_HPDP0	I	Hot plug detection signal input from the HDMI OUT A ARC connector
106	TXDSDA0	I/O	Two-way I2C serial data bus with the HDMI OUT A ARC connector
107	TXDSCL0	O	I2C serial data transfer clock signal output to the HDMI OUT A ARC connector
108	TX_HPDP1	I	Hot plug detection signal input from the HDMI OUT B connector Not used
109	TXDSDA1	I/O	Two-way I2C serial data bus with the HDMI OUT B connector Not used
110	TXDSCL1	O	I2C serial data transfer clock signal output to the HDMI OUT B connector Not used
111	APLL12	-	Power supply terminal (+1.2V)
112	XTALVCC33	-	Power supply terminal (+3.3V)
113	XTALIN	I	System clock signal input terminal (27 MHz)
114	XTALOUT	O	System clock signal output terminal Not used
115	XTALGND	-	Ground terminal
116	CVCC12	-	Power supply terminal (+1.2V)

STR-DH550/DH750

Pin No.	Pin Name	I/O	Description
117 to 120	GPIO2 to GPIO5	I/O	Not used
121	WS0_OUT	O	Word select signal output to the digital audio interface receiver
122	SCK0	O	Serial data transfer clock signal output to the digital audio interface receiver
123	IOVCC33	-	Power supply terminal (+3.3V)
124	SD0_0	I	Serial data output to the digital audio interface receiver
125	MCLK	I	Master clock signal output to the digital audio interface receiver
126 to 128	SD0_1 to SD0_3	I	Serial data output to the digital audio interface receiver
129	MUTEOUT	O	HDMI muting control signal output terminal
130	SPDIF0_OUT	I	S/PDIF audio signal output to the digital audio interface receiver
131, 132	GPIO11, GPIO10	I/O	Not used
133	SPDIF0_IN	I	S/PDIF audio signal input terminal Not used
134	SCK1_OUT	O	Serial data transfer clock signal output terminal Not used
135	WS1_OUT	O	Word select signal output terminal Not used
136	SPDIF1_OUT	I	S/PDIF audio signal output terminal Not used
137	ARC0	I	Audio signal input from the HDMI OUT A ARC connector
138	ARC1	I	Audio signal input terminal Not used
139	CVCC12	-	Power supply terminal (+1.2V)
140, 141	TPVDD12	-	Power supply terminal (+1.2V)
142	T1XC-	O	TMDS clock (negative) output to the HDMI OUT B connector Not used
143	T1XC+	O	TMDS clock (positive) output to the HDMI OUT B connector Not used
144	T1X0-	O	TMDS data (negative) output to the HDMI OUT B connector Not used
145	T1X0+	O	TMDS data (positive) output to the HDMI OUT B connector Not used
146	T1X1-	O	TMDS data (negative) output to the HDMI OUT B connector Not used
147	T1X1+	O	TMDS data (positive) output to the HDMI OUT B connector Not used
148	T1X2-	O	TMDS data (negative) output to the HDMI OUT B connector Not used
149	T1X2+	O	TMDS data (positive) output to the HDMI OUT B connector Not used
150, 151	TPVDD12	-	Power supply terminal (+1.2V)
152	T0XC-	O	TMDS clock (negative) output to the HDMI OUT A ARC connector
153	T0XC+	O	TMDS clock (positive) output to the HDMI OUT A ARC connector
154	T0X0-	O	TMDS data (negative) output to the HDMI OUT A ARC connector
155	T0X0+	O	TMDS data (positive) output to the HDMI OUT A ARC connector
156	T0X1-	O	TMDS data (negative) output to the HDMI OUT A ARC connector
157	T0X1+	O	TMDS data (positive) output to the HDMI OUT A ARC connector
158	T0X2-	O	TMDS data (negative) output to the HDMI OUT A ARC connector
159	T0X2+	O	TMDS data (positive) output to the HDMI OUT A ARC connector
160	CVCC12	-	Power supply terminal (+1.2V)
161, 162	D0, D1	O	Digital video signal output terminal Not used
163 to 170	D2 to D9	I	Digital video signal input from the video deinterlacing
171	D10	O	Digital video signal output terminal Not used
172	IDCK	I	Output data clock signal input from the video deinterlacing
173	IOVCC33	-	Power supply terminal (+3.3V)
174	D11	O	Digital video signal output terminal Not used
175, 176	D12, D13	I	Digital video signal input from the video deinterlacing

MAIN BOARD (4/7) IC2001 MB9AF156NPMC-G-JNK1E2 (SYSTEM CONTROL)

Pin No.	Pin Name	I/O	Description
1	VCC	-	Power supply pin (+3.3V)
2	DSP_INT	I	Interrupt status signal input from DSP
3	DSP_RST	O	System reset signal output to the DSP "L" reset
4	POWER_RY	O	Relay drive signal (for main power) output terminal "H": relay on
5	TUN_RDS_SIGNAL	I	RDS data signal input (for destination that support RDS only)
6	TUNER_SDA	I/O	Serial data output for tuner
7	TUNER_SCL	O	Clock signal output for tuner
8	TUNER_CE	O	Serial data latch pulse signal output to the tuner (FM/AM)
9	DAC-IIC-SDA	I/O	IIC data input/output from the D/A converter
10	DAC-IIC-SCL	O	IIC clock signal output to the D/A converter
11	BRIDGEABLE_RY	O	Relay drive signal (for power supply) output terminal "H": relay on
12	SBL_SBR_RY	O	Relay drive signal (for surround back) output terminal "H": relay on
13	SW_RY	O	Relay drive signal (subwoofer) output terminal "H": relay on
14	FRONT_SPK_RY	O	Relay drive signal (for front) output terminal "H": relay on
15	C/SL_SR_RY	O	Relay drive signal (for center and surround) output terminal "H": relay on
16	EVOL_DATA	O	Serial data output to electrical volume
17	EVOL_CLK	O	Serial data transfer clock signal output to the electrical volume
18	PROTECT	I	Protect detection signal input terminal
19	E2P_SDA	I/O	Two-way data bus with the EEPROM
20	E2P_SCL	O	Serial data transfer clock signal output to the EEPROM
21	NO_USE	-	Not used
22	NO_USE	-	Not used
23	HP-RY	O	Relay drive signal (for headphone) output terminal "H": relay on
24	HP-DETECT	I	Headphone detection signal input
25	VSS	-	Ground terminal
26	VCC	-	Power supply pin (+3.3V)
27	BT_MUTE	I	Bluetooth: Mute request from BT device to Video uCOM
28	NFC-RF-DET	I	NFC detection signal input (Only for STR-DH750)
29	P-CONT	O	Bluetooth Standby power control (Only for STR-DH750)
30	NO_USE	-	Not used
31	NO_USE	-	Not used
32	NO_USE	-	Not used
33	C	-	Regulator stabilization capacity connecting pin
34	VSS	-	Ground terminal
35	VCC	-	Power supply pin (+3.3V)
36	LED-ON	O	Power ON Green LED
37	LED-STBY	O	Standby LED
38	INITX	-	Main Micom Reset port
39	NO_USE	-	Not used
40	NO_USE	-	Not used
41	FUSE_DET	I	Fuse open detect signal input
42	FL-EN	O	Enable control for FL DISPLAY DRIVER IC
43	FL_CLK	O	Clock signal output for FL DISPLAY DRIVER IC
44	FL_DATA	O	Serial data output for FL DISPLAY DRIVER IC
45	FL_LAT	O	Latch signal output for FL DISPLAY DRIVER IC
46	MD1	-	Selection of micon operation mode (Connect to VSS)
47	MD0	-	Selection of micon operation mode (Connect to VSS)
48	X0	-	Main oscillator connecting pin
49	X1	-	Main oscillator connecting pin
50	VSS	-	Ground terminal
51	VCC	-	Power supply pin (+3.3V)
52	INPUT_JOG	I	Function encoder signal input
53	SIRCS_IN	I	SIRCS signal input
54	VOLUME_JOG	I	MASTER VOLUME encoder signal input
55	AD_KEY1	I	Key signal input (A/D port)

Pin No.	Pin Name	I/O	Description
56	POWER_KEY	I	Power switch input terminal
57	AD_KEY2	I	Key signal input (A/D port)
58	PUREDIRECT	I	Disable FL display
59	MU UART IN	I	IIC data input from the video micom
60	AVCC	-	Analog power supply pin for A/D converter
61	AVRH	-	Standard power supply pin for A/D converter
62	AVSS	-	Analog ground for A/D converter
63	VCOM_SDA (OUT)	O	IIC data output to the video micom
64	HDMI_CEC_OUT	O	CEC serial data output to the HDMI connector
65	HDMI_CEC_IN	I	CEC serial data input from the HDMI connector
66	STOP	I	AC off detection signal input
67	LIMITER	I	Limiter signal input
68	DIR_FSRATE	I	Sampling rate frequency from the digital audio interface receiver
69	TEMP_SENSOR_2	I	Thermal detection signal input from the thermal sensor
70	TEMP_SENSOR_1	I	Thermal detection signal input from the thermal sensor
71	FLASH_CLK	O	In Line programming clock data line
72	SO	O	Serial data output terminal (use for Firmware Flash Program)
73	SI	I	Serial data input terminal (use for Firmware Flash Program)
74	DIR_SIGNAL	I	Audio serial data input from the digital audio interface receiver
75	VSS	-	Ground terminal
76	VCC	-	Power supply pin (+3.3V)
77	DIR_XSTATE	I	Clock selection signal input from the digital audio interface receiver
78	TCK	-	Test clock signal input terminal (for JTAG)
79	TDI	-	Test data input terminal (for JTAG)
80	TMS	-	Test mode selection signal input terminal (for JTAG)
81	TD0	-	Test data output terminal (for JTAG) Not used
82	DIR_MISO	I	Serial data input from digital audio interface receiver
83	DIR_MOSI	O	Serial data output to digital audio interface receiver
84	DIR_SPICLK	O	Serial clock output to digital audio interface receiver
85	DIR_CE	O	Chip enable signal output to the digital audio interface receiver
86	DIR_SIGNAL	I	Audio serial data input from the digital audio interface receiver
87	DIR_RST	O	Reset signal output to the digital audio interface receiver
88	DSP_SFLASH_HOLD	O	Hold signal output to the serial flash
89	DSP_NLPCM	I	SPDIF / IIS NLPCM signal input from digital audio interface receiver / HDMI receiver
90	DSP_ERROR	I	SPDIF / IIS Error signal input from digital audio interface receiver / HDMI receiver
91	DSP_SPICS	O	Chip select signal output to DSP
92	PROG_VU_MD0	O	Programming (video micom)
93	VU_RST	O	Video micom reset signal output terminal
94	DSP_SPICLK	O	Serial data transfer clock signal output to the serial flash and DSP
95	DSP_MOSI	O	Serial data output to the serial flash and DSP
96	DSP_MISO	I	Serial data input from the serial flash and DSP
97	VCC	-	Power supply pin (+3.3V)
98	VSEL-SW	O	Composite video output signal switch
99	VMUTE	O	Video muting control signal output to the video amplifier
100	VSS	-	Ground terminal

MAIN BOARD (7/7) IC2602 MB9AF156NPMC-G-JNK1E2 (HDMI CONTROLLER)

Pin No.	Pin Name	I/O	Description
1	VCC	-	Power supply pin (+3.3V)
2	NO_USE	-	Not used
3	NO_USE	-	Not used
4	NO_USE	-	Not used
5	MHL-OVC	I	MHL over current detection
6	TEST_SCK	O	Not used
7	TEST_SDA	O	Not used
8	NO_USE	-	Not used
9	APPLE_RST	O	Reset pin for Apple certification.
10	APPLE_SCL	O	I2C SCL for Apple certification IC
11	APPLE_SDA	I/O	I2C SDA for Apple certification IC
12	UPDATE-LED	I	USB Update: USB Update LED Control
13	HDMI-NLPCM	I	HDMI: Non LPCM Stream Info Line Notification
14	NO_USE	-	Not used
15	NO_USE	-	Not used
16	NO_USE	-	Not used
17	NO_USE	-	Not used
18	TEST-1	O	Test Pad 1 (for designer evaluation only)
19	TEST-2	O	Test Pad 2 (for designer evaluation only)
20	TEST-3	O	Test Pad 3 (for designer evaluation only)
21	TEST-4	O	Test Pad 4 (for designer evaluation only)
22	TEST-5	O	Test Pad 5 (for designer evaluation only)
23	TEST-6	O	Test Pad 6 (for designer evaluation only)
24	TEST-7	O	Test Pad 7 (for designer evaluation only)
25	VSS	-	Ground terminal
26	VCC	-	Power supply pin (+3.3V)
27	PROG_MUTX	I	Programming pin (Uart TX pin)
28	PROG_MURX	O	Programming pin (Uart RX pin)
29	NO_USE	-	Not used
30	MHL-PCONT	O	MHL Power control
31	HDMIOUT-5VPWR	O	HDMI 5V detect pin
32	HDMI_PCONT	O	HDMI power control pin
33	C	-	Regulator stabilization capacity connecting pin
34	VSS	-	Ground terminal
35	VCC	-	Power supply pin (+3.3V)
36	SPARTA_RST	O	HDMI device reset control port
37	HDMI_MUTE	O	HDMI: Audio Mute Request
38	INITX	-	Video Micom Reset port
39	SPARTA_INT	I	HDMI device interrupt port
40	HDMI_SDA	I/O	HDMI: Communication Line - I2C SDA for HDMI-Rx, HDMI-Tx, EDID device
41	HDMI_SCL	O	HDMI I2C clock pin.
42	PROG_MU_MD0	O	Programming USB Update MD0 select
43	MU_RST	O	USB Update: USB Update Main Micom Reset
44	MU_UART IN	O	Communication between Main and Video line.(Uart RX)
45	VCOM_SDA (OUT)	I	Communication between Main and Video line. (Uart Tx)
46	MD1	-	UCOM Mode setting terminal
47	MD0	-	UCOM Mode setting terminal
48	X0	-	Main oscillator connecting pin
49	X1	-	Main oscillator connecting pin
50	VSS	-	Ground terminal
51	VCC	-	Power supply pin (+3.3V)
52	NFC_SW	O	NFC switch (Only for STR-DH750)
53	NFC_IRQ	I	NFC interrupt pin (Only for STR-DH750)
54	NFC_DATA	I/O	NFC data line (Only for STR-DH750)
55	NO_USE	-	Not used

STR-DH550/DH750

Pin No.	Pin Name	I/O	Description
56	NO_USE	-	Not used
57	NFC_SEL	O	NFC select pin (Only for STR-DH750)
58	NO_USE	-	Not used
59	NO_USE	-	Not used
60	AVCC	-	A/D converter power supply terminal / Analog power supply pin for A/D converter
61	AVRH	-	ADC analog reference voltage input / Standard power supply pin for A/D converter
62	AVSS	-	A/D converter terminal GND / Analog ground for A/D converter
63	No_Use	-	Not used
64	BT_PCONT	O	Bluetooth: Power control for BT device
65	BT_VUTX_BTRX	O	Bluetooth: UART Rx on Video uCOM from BT device
66	BT_VURX_BTTX	I	Bluetooth: UART Tx on Video uCOM to BT device
67	BT_RST	O	Bluetooth: RESET for BT device
68	VURTSOUT_BTCTS	O	Bluetooth: RTS on Video uCOM
69	VUCTSIN_BTRTS	O	Bluetooth: CTS on Video uCOM
70	NO_USE	-	Not used
71	Prog_VU_SCK	O	Programming Clock (video micom)
72	Prog_VUTX	O	Programming UART TX (video micom)
73	Prog_VURX	I	Programming UART RX (video micom)
74	NO_USE	I	Not used
75	VSS	-	Ground terminal
76	VCC	-	Power supply pin (+3.3V)
77	TRXTS (No Use)	-	Not used
78	TCK	-	Test clock signal input terminal (for JTAG)
79	TDI	-	Test data input terminal (for JTAG)
80	TMS	-	Test mode selection signal input terminal (for JTAG)
81	TDO	-	Test data output terminal (for JTAG) Not used
82	NO_USE	-	Not used
83	NO_USE	-	Not used
84	NO_USE	-	Not used
85	NO_USE	-	Not used
86	NO_USE	-	Not used
87	NO_USE	-	Not used
88	NFC_RFDET	I	NFC DRF detect pin (Only for STR-DH750)
89	NFC_SPICLK	O	Serial data transfer clock signal output to the NFC
90	USB_BUSY	O	BUSY signal communication between USB board
91	USB_RESET	O	USB: RESET for USB Device BU94604BKV
92	USB_SEARCH	I	USB: SEARCH signal communication between USB board
93	USB_IRPTO	I	USB: IRPTO (notification that two USB configuration descriptor or more is connected) from USB Device BU94604BKV
94	USB_SCL	O	USB: Communication Line I2C SDL
95	USB_SDA	I/O	USB: Communication Line I2C SDA
96	USB_MCHNG	O	USB: MCHNG (change of music file being playback) to USB Device BU94604BKV
97	VCC	-	Power supply pin (+3.3V)
98	USB_PCONT	I	USB: Power control for USB device
99	USB_OVC	I	USB: Overcurrent Detection
100	VSS	-	Ground terminal

6-2. FRONT PANEL SECTION

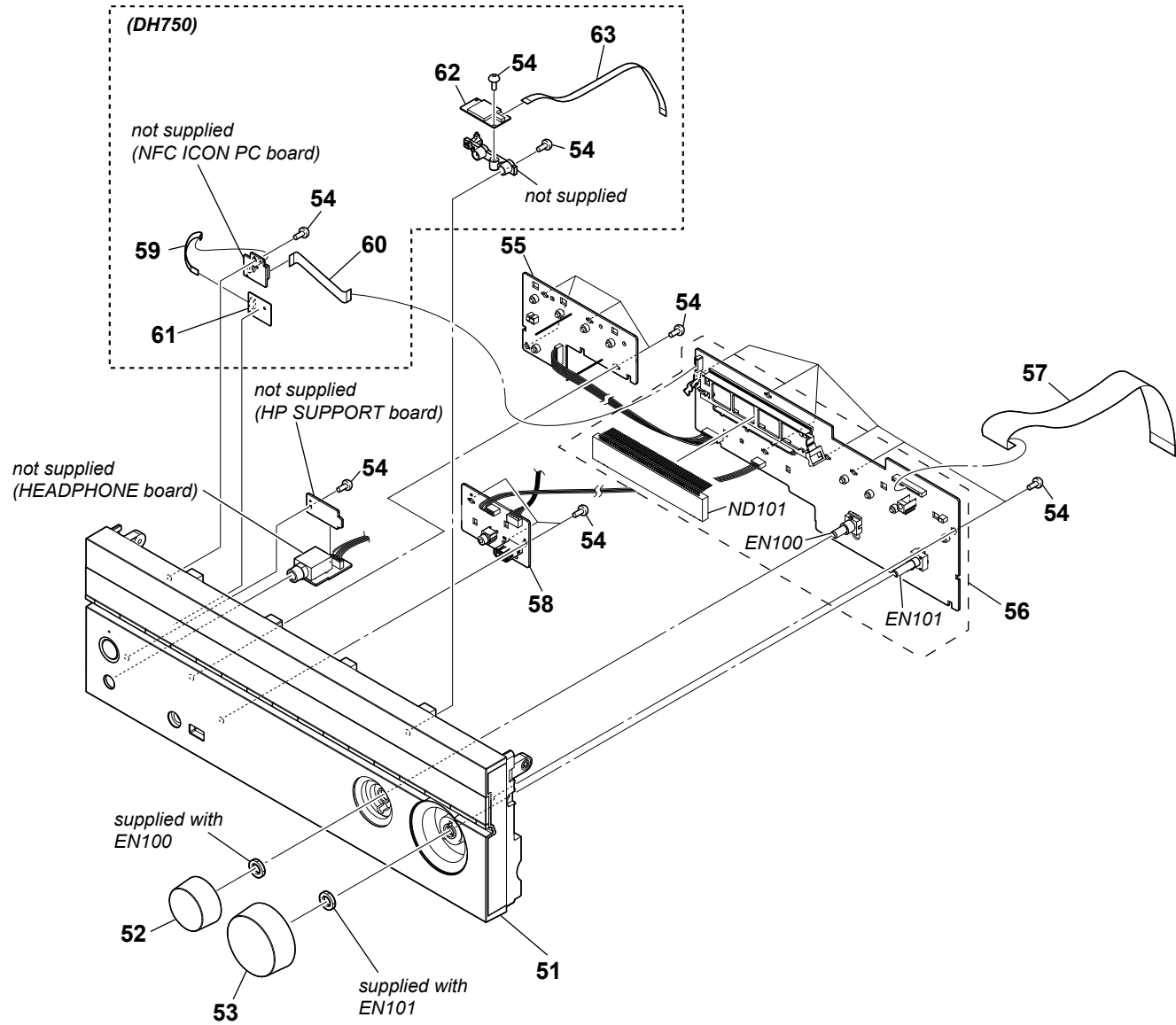

Note: If wire (flat type) is replaced, install it after bending it in the same form as that before replacement.

Ref. No.	Part No.	Description	Remark	Ref. No.	Part No.	Description	Remark
51	X-2588-835-1	FRONT PANEL ASSY (DH750: US, CND)		57	1-828-412-61	WIRE (FLAT TYPE) (29 CORE)	
51	X-2588-837-1	FRONT PANEL ASSY (DH750: AEP, UK, AUS, MX, BR, TW)		58	A-1989-184-A	FRONT JACK BOARD, COMPLETE	
51	X-2588-840-1	FRONT PANEL ASSY (DH550: US, CND)		59	1-828-167-61	WIRE (FLAT TYPE) (8 CORE) (DH750)	
51	X-2588-841-1	FRONT PANEL ASSY (DH550: AEP, UK, AUS)		60	1-828-308-61	WIRE (FLAT TYPE) (9 CORE) (DH750)	
52	4-442-859-01	KNOB, MENU		61	8-989-470-05	RC-S801/A5 (WW) (DH750)	
53	4-442-860-01	KNOB, VOLUME		62	1-490-558-71	BLUETOOTH MODULE (DH750)	
54	3-087-053-01	+BVTP2.6 (3CR)		63	1-828-202-61	WIRE (FLAT TYPE) (14 CORE) (DH750)	
55	A-1989-183-A	POWER KEY BOARD, COMPLETE		EN100	1-418-817-21	ENCODER, ROTARY (INPUT SELECTOR)	
56	A-1989-480-A	DISPLAY BOARD, COMPLETE (DH750)		EN101	1-418-725-41	ENCODER, ROTARY (12 TYPE)	(MASTER VOLUME)
56	A-1989-626-A	DISPLAY BOARD, COMPLETE (DH550)		ND101	1-483-517-11	VACUUM FLUORESCENT DISPLAY	

6-3. BACK PANEL SECTION

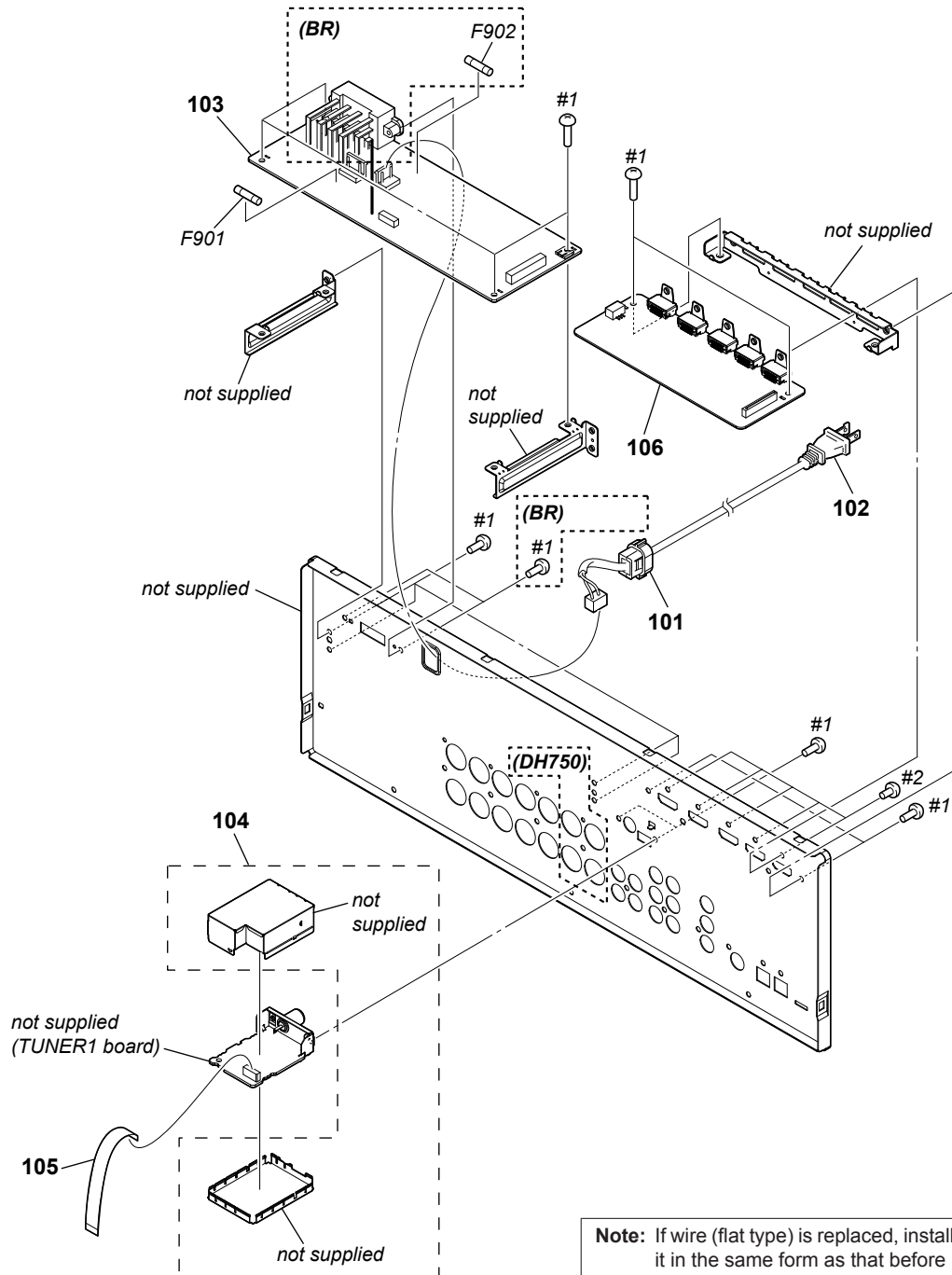

Ref. No.	Part No.	Description	Remark	Ref. No.	Part No.	Description	Remark
	101	4-966-267-12	BUSHING (FBS001), CORD		103	A-1989-634-A	STANDBY DCDC BOARD, COMPLETE (DH550: AEP, UK, AUS)
△	102	1-777-071-83	CORD, POWER (AEP)		104	A-1846-561-A	TUNER1AMPR ASSY (AEP, UK, AUS, TW)
△	102	1-833-566-21	POWER-SUPPLY CORD (AUS)		104	A-1846-564-A	TUNER1AMF ASSY (US, CND, MX, BR)
△	102	1-835-706-22	CORD, POWER-SUPPLY (BR)		105	1-828-308-61	WIRE (FLAT TYPE) (9 CORE)
△	102	1-837-308-11	CORD, POWER-SUPPLY (US, CND)		106	A-1989-867-A	HDMI BOARD, COMPLETE (for SERVICE)
△	102	1-837-344-11	CORD, POWER-SUPPLY (MX)	△	F901	1-532-465-33	FUSE (T3.15AL/250V) (AEP, AUS, UK)
△	102	1-837-345-11	CORD, POWER-SUPPLY (TW)	△	F901	1-532-504-33	FUSE, (T4AL/250V) (BR)
△	102	1-839-999-21	POWER-SUPPLY CORD (UK)	△	F901	1-532-506-33	FUSE, (T6.3AL/250V) (MX, TW)
	103	A-1988-684-A	STANDBY DCDC BOARD, COMPLETE (DH750: US, CND, MX, TW)	△	F901	1-533-311-12	FUSE, GLASS (DIA.5) (8A/125V) (US, CND)
	103	A-1989-572-A	STANDBY DCDC BOARD, COMPLETE (DH750: AEP, UK, AUS)	△	F902	1-532-506-33	FUSE, (T6.3AL/250V) (BR)
	103	A-1989-616-A	STANDBY DCDC BOARD, COMPLETE (BR)	#1	7-685-646-71	SCREW +BVTP 3X8 TYPE2 IT-3	
	103	A-1989-624-A	STANDBY DCDC BOARD, COMPLETE (DH550: US, CND)	#2	7-682-546-09	SCREW +B 3X5	

6-4. CHASSIS SECTION

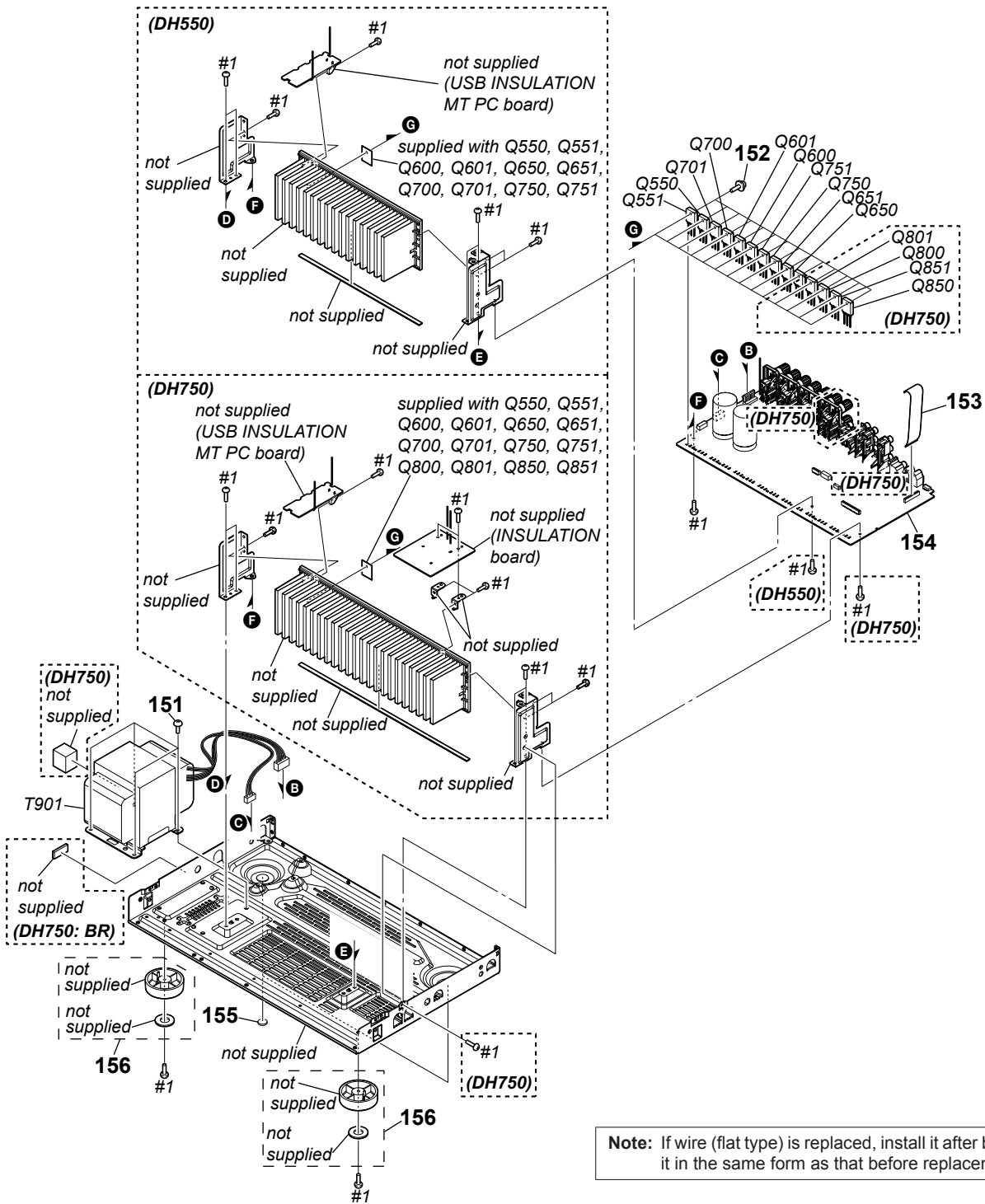

Ref. No.	Part No.	Description	Remark	Ref. No.	Part No.	Description	Remark
151	4-249-675-02	+BV SUMITITE S 4X6 ROUND		Q701	6-702-391-01	TRANSISTOR MP1620-OPY-MK	
152	3-905-609-31	SCREW (TRANSISTOR)		Q750	6-702-390-01	TRANSISTOR MN2488-OPY-MK	
153	1-828-379-61	WIRE (FLAT TYPE) (23 CORE)		Q751	6-702-391-01	TRANSISTOR MP1620-OPY-MK	
154	A-1988-674-A	MAIN BOARD, COMPLETE (DH750)		Q800	6-702-390-01	TRANSISTOR MN2488-OPY-MK (DH750)	
154	A-1989-623-A	MAIN BOARD, COMPLETE (DH550)		Q801	6-702-391-01	TRANSISTOR MP1620-OPY-MK (DH750)	
155	4-447-491-01	CUSHION, FOOT		Q850	6-702-390-01	TRANSISTOR MN2488-OPY-MK (DH750)	
156	X-2583-799-2	ASSY, FOOT		Q851	6-702-391-01	TRANSISTOR MP1620-OPY-MK (DH750)	
Q550	6-702-390-01	TRANSISTOR MN2488-OPY-MK		△ T901	1-697-237-21	POWER TRANSFORMER (MAIN) (MX)	
Q551	6-702-391-01	TRANSISTOR MP1620-OPY-MK		△ T901	1-697-238-21	POWER TRANSFORMER (MAIN) (BR)	
Q600	6-702-390-01	TRANSISTOR MN2488-OPY-MK		△ T901	1-697-367-11	POWER TRANSFORMER (MAIN) (AEP, UK, AUS)	
Q601	6-702-391-01	TRANSISTOR MP1620-OPY-MK		△ T901	1-697-368-11	POWER TRANSFORMER (MAIN) (US, CND, TW)	
Q650	6-702-390-01	TRANSISTOR MN2488-OPY-MK		#1	7-685-646-71	SCREW +BVTP 3X8 TYPE2 IT-3	
Q651	6-702-391-01	TRANSISTOR MP1620-OPY-MK					
Q700	6-702-390-01	TRANSISTOR MN2488-OPY-MK					

STR-DH550/DH750

DISPLAY

Ref. No.	Part No.	Description	Remark	Ref. No.	Part No.	Description	Remark
JR113	1-216-864-11	SHORT CHIP	0			< FLUORESCENT INDICATOR TUBE >	
JR133	1-216-296-11	SHORT CHIP	0				
JR134	1-216-296-11	SHORT CHIP	0	ND101	1-483-517-11	VACUUM FLUORESCENT DISPLAY	
JR135	1-216-296-11	SHORT CHIP	0			< TRANSISTOR >	
JR136	1-216-296-11	SHORT CHIP	0	Q101	6-552-713-01	TR QS5W2TR	
JR137	1-216-296-11	SHORT CHIP	0	Q102	6-553-266-01	TR 2PD601ART	
JR138	1-216-296-11	SHORT CHIP	0	Q103	6-553-268-01	TR PDTC114ET	
JR139	1-216-296-11	SHORT CHIP	0	Q104	6-551-728-01	TRANSISTOR 2SB1710TL	
JR140	1-216-296-11	SHORT CHIP	0			< RESISTOR >	
JR141	1-216-296-11	SHORT CHIP	0	R112	1-218-285-11	METAL CHIP 75 5%	1/10W
JR142	1-216-296-11	SHORT CHIP	0	R113	1-216-797-11	METAL CHIP 10 5%	1/10W
JR143	1-216-296-11	SHORT CHIP	0	R114	1-216-839-11	METAL CHIP 33K 5%	1/10W
JR144	1-216-296-11	SHORT CHIP	0	R115	1-216-829-11	METAL CHIP 4.7K 5%	1/10W
JR145	1-216-864-11	SHORT CHIP	0	R116	1-216-829-11	METAL CHIP 4.7K 5%	1/10W
JR146	1-216-296-11	SHORT CHIP	0	R117	1-216-829-11	METAL CHIP 4.7K 5%	1/10W
JR147	1-216-296-11	SHORT CHIP	0	R118	1-216-841-11	METAL CHIP 47K 5%	1/10W
JR148	1-216-296-11	SHORT CHIP	0	R119	1-216-841-11	METAL CHIP 47K 5%	1/10W
JR149	1-216-296-11	SHORT CHIP	0	R120	1-216-296-11	SHORT CHIP 0	
JR150	1-216-296-11	SHORT CHIP	0	R121	1-216-829-11	METAL CHIP 4.7K 5%	1/10W
JR151	1-216-296-11	SHORT CHIP	0	R122	1-216-821-11	METAL CHIP 1K 5%	1/10W
JR152	1-216-296-11	SHORT CHIP	0	R123	1-216-833-11	METAL CHIP 10K 5%	1/10W
JR153	1-216-296-11	SHORT CHIP	0	R124	1-216-841-11	METAL CHIP 47K 5%	1/10W
JR154	1-216-296-11	SHORT CHIP	0	R125	1-218-866-11	METAL CHIP 6.2K 0.5%	1/10W
JR156	1-216-296-11	SHORT CHIP	0	R126	1-216-842-11	METAL CHIP 56K 5%	1/10W
JR157	1-216-296-11	SHORT CHIP	0	R127	1-218-867-11	METAL CHIP 6.8K 0.5%	1/10W
JR158	1-216-296-11	SHORT CHIP	0	R128	1-216-821-11	METAL CHIP 1K 5%	1/10W
JR159	1-216-296-11	SHORT CHIP	0	R129	1-216-845-11	METAL CHIP 100K 5%	1/10W
JR160	1-216-296-11	SHORT CHIP	0	R130	1-250-616-11	METAL CHIP 1K 1%	1/10W
JR162	1-216-296-11	SHORT CHIP	0	R131	1-250-624-11	METAL CHIP 2.2K 1%	1/10W
JR163	1-216-296-11	SHORT CHIP	0	R132	1-250-632-11	METAL CHIP 4.7K 1%	1/10W
JR164	1-216-296-11	SHORT CHIP	0	R133	1-250-624-11	METAL CHIP 2.2K 1%	1/10W
JR165	1-216-296-11	SHORT CHIP	0	R134	1-250-624-11	METAL CHIP 2.2K 1%	1/10W
JR166	1-216-296-11	SHORT CHIP	0	R135	1-250-616-11	METAL CHIP 1K 1%	1/10W
JR170	1-216-296-11	SHORT CHIP	0	R136	1-250-592-11	METAL CHIP 100 1%	1/10W
JR171	1-216-296-11	SHORT CHIP	0	R137	1-250-592-11	METAL CHIP 100 1%	1/10W
JR172	1-216-296-11	SHORT CHIP	0	R139	1-249-428-11	CARBON 8.2K 5%	1/4W
JR173	1-216-296-11	SHORT CHIP	0	R140	1-250-612-11	METAL CHIP 680 1%	1/10W
JR174	1-216-296-11	SHORT CHIP	0	R142	1-250-640-11	METAL CHIP 10K 1%	1/10W
JR176	1-216-296-11	SHORT CHIP	0	R143	1-250-600-11	METAL CHIP 220 1%	1/10W
JR177	1-216-296-11	SHORT CHIP	0	R144	1-250-664-11	METAL CHIP 100K 1%	1/10W
JR178	1-216-296-11	SHORT CHIP	0	R145	1-250-640-11	METAL CHIP 10K 1%	1/10W
JR180	1-216-296-11	SHORT CHIP	0	R146	1-250-648-11	METAL CHIP 22K 1%	1/10W
JR181	1-216-296-11	SHORT CHIP	0	R147	1-250-640-11	METAL CHIP 10K 1%	1/10W
JR182	1-216-296-11	SHORT CHIP	0	R148	1-250-648-11	METAL CHIP 22K 1%	1/10W
JR183	1-216-296-11	SHORT CHIP	0	R149	1-250-612-11	METAL CHIP 680 1%	1/10W
JR184	1-216-296-11	SHORT CHIP	0	R150	1-250-608-11	METAL CHIP 470 1%	1/10W
JR185	1-216-296-11	SHORT CHIP	0	R151	1-249-428-11	CARBON 8.2K 5%	1/4W
JR186	1-216-296-11	SHORT CHIP	0	R153	1-216-843-11	METAL CHIP 68K 5%	1/10W
JR187	1-216-296-11	SHORT CHIP	0	R154	1-216-809-11	METAL CHIP 100 5%	1/10W
JR188	1-216-296-11	SHORT CHIP	0	R156	1-250-664-11	METAL CHIP 100K 1%	1/10W (DH750)
JR189	1-216-296-11	SHORT CHIP	0	R157	1-216-864-11	SHORT CHIP 0	
JR190	1-216-296-11	SHORT CHIP	0	R158	1-216-809-11	METAL CHIP 100 5%	1/10W
JR191	1-216-296-11	SHORT CHIP	0	R159	1-216-809-11	METAL CHIP 100 5%	1/10W
JR192	1-216-296-11	SHORT CHIP	0	R160	1-216-809-11	METAL CHIP 100 5%	1/10W
JR193	1-216-296-11	SHORT CHIP	0	R162	1-216-864-11	SHORT CHIP 0	
JR194	1-216-296-11	SHORT CHIP	0	R165	1-216-864-11	SHORT CHIP 0	
JR195	1-216-296-11	SHORT CHIP	0	R167	1-218-285-11	METAL CHIP 75 5%	1/10W
		< COIL >		R168	1-218-285-11	METAL CHIP 75 5%	1/10W
L102	1-410-671-31	INDUCTOR	47uH				

DISPLAY	FRONT JACK	HDMI
---------	------------	------

Ref. No.	Part No.	Description	Remark	Ref. No.	Part No.	Description	Remark
R169	1-218-285-11	METAL CHIP 75 5%	1/10W	C3517	1-116-724-11	CERAMIC CHIP 4.7uF 20%	6.3V
R170	1-218-285-11	METAL CHIP 75 5%	1/10W	* C3518	1-118-035-11	CERAMIC CHIP 0.1uF 10%	25V
R171	1-218-285-11	METAL CHIP 75 5%	1/10W	* C3519	1-118-035-11	CERAMIC CHIP 0.1uF 10%	25V
R193	1-216-809-11	RES-CHIP 100 5%	1/10W	* C3520	1-118-035-11	CERAMIC CHIP 0.1uF 10%	25V
< SWITCH >				* C3523	1-118-035-11	CERAMIC CHIP 0.1uF 10%	25V
S101	1-762-875-21	SWITCH, TACTILE (PURE DIRECT)		C3525	1-116-724-11	CERAMIC CHIP 4.7uF 20%	6.3V
S102	1-762-875-21	SWITCH, TACTILE (DIMMER)		* C3526	1-118-035-11	CERAMIC CHIP 0.1uF 10%	25V
S103	1-762-875-21	SWITCH, TACTILE (DISPLAY)		C3527	1-116-724-11	CERAMIC CHIP 4.7uF 20%	6.3V
S104	1-762-875-21	SWITCH, TACTILE (CONNECTION ● PAIRING BLUETOOTH) (DH750), (INPUT MODE) (DH550)		* C3528	1-118-035-11	CERAMIC CHIP 0.1uF 10%	25V
S105	1-762-875-21	SWITCH, TACTILE (NIGHT MODE)		* C3529	1-118-035-11	CERAMIC CHIP 0.1uF 10%	25V
S108	1-762-875-21	SWITCH, TACTILE (A.F.D./2CH)		C3530	1-116-737-11	CERAMIC CHIP 1uF 20%	10V
S109	1-762-875-21	SWITCH, TACTILE (MOVIE)		C3531	1-116-737-11	CERAMIC CHIP 1uF 20%	10V
S110	1-762-875-21	SWITCH, TACTILE (MUSIC)		C3532	1-116-724-11	CERAMIC CHIP 4.7uF 20%	6.3V
< TRANSFORMER >				* C3533	1-116-720-11	CERAMIC CHIP 10uF 20%	6.3V
T100	1-443-645-11	TRANSFORMER, DC CONVERTER		C3534	1-116-737-11	CERAMIC CHIP 1uF 20%	10V
*****				* C3536	1-118-035-11	CERAMIC CHIP 0.1uF 10%	25V
A-1989-184-A	FRONT JACK BOARD, COMPLETE			* C3538	1-116-720-11	CERAMIC CHIP 10uF 20%	6.3V
*****				* C3540	1-118-035-11	CERAMIC CHIP 0.1uF 10%	25V
< CAPACITOR >				* C3541	1-116-720-11	CERAMIC CHIP 10uF 20%	6.3V
C150	1-107-826-91	CERAMIC CHIP 0.1uF 10%	16V	* C3542	1-118-035-11	CERAMIC CHIP 0.1uF 10%	25V
C151	1-126-176-11	ELECT 220uF 20%	10V	* C3543	1-116-720-11	CERAMIC CHIP 10uF 20%	6.3V
C152	1-114-325-11	CERAMIC CHIP 0.1uF 10%	25V	* C3544	1-118-035-11	CERAMIC CHIP 0.1uF 10%	25V
C154	1-116-743-11	CERAMIC CHIP 0.22uF 10%	16V	* C3545	1-116-720-11	CERAMIC CHIP 10uF 20%	6.3V
< CONNECTOR >				* C3546	1-118-035-11	CERAMIC CHIP 0.1uF 10%	25V
CN104	1-564-721-11	PIN, CONNECTOR (SMALL TYPE) 5P		* C3548	1-118-035-11	CERAMIC CHIP 0.1uF 10%	25V
CN106	1-819-866-11	USB CONNECTOR (A) (⚡ DC5V ≡ 1A MAX)		C3549	1-164-843-11	CERAMIC CHIP 3PF 0.25PF	50V
< DIODE >				C3550	1-164-843-11	CERAMIC CHIP 3PF 0.25PF	50V
D126	6-502-968-01	DI DZ2J062M0L		* C3551	1-116-720-11	CERAMIC CHIP 10uF 20%	6.3V
D129	6-500-400-01	DIODE BAV99-215		* C3552	1-118-035-11	CERAMIC CHIP 0.1uF 10%	25V
D130	6-500-400-01	DIODE BAV99-215		* C3553	1-118-035-11	CERAMIC CHIP 0.1uF 10%	25V
< JACK >				* C3554	1-118-035-11	CERAMIC CHIP 0.1uF 10%	25V
J100	1-822-453-11	SMALL TYPE JACK (3.5MM) (AUTO CAL MIC)		* C3555	1-118-035-11	CERAMIC CHIP 0.1uF 10%	25V
< JUMPER RESISTOR >				* C3556	1-116-720-11	CERAMIC CHIP 10uF 20%	6.3V
JR200	1-216-296-11	SHORT CHIP 0		* C3557	1-118-035-11	CERAMIC CHIP 0.1uF 10%	25V
JR201	1-216-296-11	SHORT CHIP 0		* C3558	1-118-035-11	CERAMIC CHIP 0.1uF 10%	25V
< RESISTOR >				* C3559	1-118-035-11	CERAMIC CHIP 0.1uF 10%	25V
R190	1-216-864-11	SHORT CHIP 0		* C3560	1-116-720-11	CERAMIC CHIP 10uF 20%	6.3V
R191	1-216-864-11	SHORT CHIP 0		* C3561	1-116-720-11	CERAMIC CHIP 10uF 20%	6.3V
R192	1-216-864-11	SHORT CHIP 0		* C3562	1-116-720-11	CERAMIC CHIP 10uF 20%	6.3V
*****				* C3563	1-116-720-11	CERAMIC CHIP 10uF 20%	6.3V
A-1989-867-A	HDMI BOARD, COMPLETE (for SERVICE)			* C3564	1-116-720-11	CERAMIC CHIP 10uF 20%	6.3V
*****				* C3565	1-116-720-11	CERAMIC CHIP 10uF 20%	6.3V
C3358	1-116-737-11	CERAMIC CHIP 1uF 20%	10V	C3566	1-100-354-21	ELECT CHIP 220uF 20%	6.3V
C3359	1-116-737-11	CERAMIC CHIP 1uF 20%	10V	C3567	1-100-354-21	ELECT CHIP 220uF 20%	6.3V
C3361	1-116-737-11	CERAMIC CHIP 1uF 20%	10V	C3570	1-118-459-11	CERAMIC CHIP 0.01uF 10%	25V
C3363	1-116-737-11	CERAMIC CHIP 1uF 20%	10V	C3578	1-118-403-11	CERAMIC CHIP 0.001uF 10%	50V
C3364	1-116-737-11	CERAMIC CHIP 1uF 20%	10V	* C3596	1-118-035-11	CERAMIC CHIP 0.1uF 10%	25V
* C3513	1-118-035-11	CERAMIC CHIP 0.1uF 10%	25V	* C3597	1-118-035-11	CERAMIC CHIP 0.1uF 10%	25V
				* C3598	1-118-035-11	CERAMIC CHIP 0.1uF 10%	25V
				C3599	1-118-388-11	CERAMIC CHIP 0.047uF 10%	25V
				C3602	1-116-717-11	CERAMIC CHIP 10uF 20%	10V
				* C3603	1-118-035-11	CERAMIC CHIP 0.1uF 10%	25V
				C3604	1-118-040-11	CERAMIC CHIP 2.2uF 10%	16V
				* C3605	1-118-035-11	CERAMIC CHIP 0.1uF 10%	25V
				C3606	1-118-040-11	CERAMIC CHIP 2.2uF 10%	16V
				* C3607	1-118-035-11	CERAMIC CHIP 0.1uF 10%	25V
				C3608	1-100-354-21	ELECT CHIP 220uF 20%	6.3V
				* C3609	1-116-719-11	CERAMIC CHIP 10uF 10%	6.3V

STR-DH550/DH750

HDMI

Ref. No.	Part No.	Description	Remark	Ref. No.	Part No.	Description	Remark
		< CONNECTOR >		R3520	1-218-973-11	METAL CHIP 47K	5% 1/16W
CN3200	1-821-398-41	HDMI CONNECTOR (HDMI OUT TV OUT ARC)		R3521	1-218-973-11	METAL CHIP 47K	5% 1/16W
CN3501	1-821-398-41	HDMI CONNECTOR		R3523	1-218-973-11	METAL CHIP 47K	5% 1/16W
		(HDMI IN VIDEO (MHL) DC5V == 1A MAX)		R3549	1-218-965-11	METAL CHIP 10K	5% 1/16W
CN3502	1-821-398-41	HDMI CONNECTOR		R3551	1-218-965-11	METAL CHIP 10K	5% 1/16W
		(HDMI IN BD/DVD (for AUDIO))		R3552	1-218-965-11	METAL CHIP 10K	5% 1/16W
CN3503	1-821-398-41	HDMI CONNECTOR (HDMI IN GAME)		R3555	1-218-953-11	METAL CHIP 1K	5% 1/16W
CN3504	1-821-398-41	HDMI CONNECTOR (HDMI IN SAT/CATV)		R3556	1-218-965-11	METAL CHIP 10K	5% 1/16W
				R3560	1-218-965-11	METAL CHIP 10K	5% 1/16W
CN3511	1-785-466-51	CONNECTOR, FFC/FPC 7P		R3567	1-218-937-11	METAL CHIP 47	5% 1/16W
CN3513	1-794-509-11	PIN, CONNECTOR (PC BOARD) (3P)		R3568	1-218-937-11	METAL CHIP 47	5% 1/16W
CN3514	1-820-121-51	CONNECTOR, FFC/FPC 23P		R3569	1-218-937-11	METAL CHIP 47	5% 1/16W
		< DIODE >		R3570	1-218-937-11	METAL CHIP 47	5% 1/16W
D3501	6-503-738-01	DI CES521		R3573	1-218-959-11	METAL CHIP 3.3K	5% 1/16W
		< FERRITE BEAD >		R3576	1-218-957-11	METAL CHIP 2.2K	5% 1/16W
FB3501	1-481-348-21	EMI FERRITE (SMD) (1608)		R3578	1-218-957-11	METAL CHIP 2.2K	5% 1/16W
FB3504	1-414-772-11	FERRITE, EMI (SMD) (2012)		R3579	1-218-990-81	SHORT CHIP 0	
FB3505	1-481-348-21	EMI FERRITE (SMD) (1608)		R3582	1-218-961-11	METAL CHIP 4.7K	5% 1/16W
		< IC >		R3583	1-218-961-11	METAL CHIP 4.7K	5% 1/16W
IC3511	6-718-999-01	IC MM1839A50NRE		R3584	1-218-965-11	METAL CHIP 10K	5% 1/16W
IC3512	A-1989-869-A	IC W25Q16CVSSIG-R (for SERVICE)		R3585	1-218-965-11	METAL CHIP 10K	5% 1/16W
IC3513	6-719-139-01	IC MM3411A50NRE		R3588	1-218-929-11	METAL CHIP 10	5% 1/16W
IC3514	(Not supplied)	IC SII9573CTUC		R3589	1-218-937-11	METAL CHIP 47	5% 1/16W
IC3517	6-718-379-01	IC RP108J081D-FE		R3590	1-218-937-11	METAL CHIP 47	5% 1/16W
IC3518	6-715-164-01	IC TPS2553DBVR		R3591	1-218-965-11	METAL CHIP 10K	5% 1/16W
IC3519	6-717-006-01	IC BD00HC5WEFJ-E2		R3593	1-218-953-11	METAL CHIP 1K	5% 1/16W
		< COIL >		R3594	1-218-965-11	METAL CHIP 10K	5% 1/16W
L3500	1-469-525-91	INDUCTOR 10uH		R3595	1-218-961-11	METAL CHIP 4.7K	5% 1/16W
		< RESISTOR >		R3596	1-218-929-11	METAL CHIP 10	5% 1/16W
R3365	1-218-965-11	METAL CHIP 10K	5% 1/16W	R3597	1-218-961-11	METAL CHIP 4.7K	5% 1/16W
R3370	1-208-874-81	METAL CHIP 300	0.5% 1/16W	R3598	1-218-929-11	METAL CHIP 10	5% 1/16W
R3372	1-220-168-81	METAL CHIP 62	5% 1/16W	R3599	1-218-961-11	METAL CHIP 4.7K	5% 1/16W
R3373	1-218-990-81	SHORT CHIP 0		R3600	1-218-961-11	METAL CHIP 4.7K	5% 1/16W
R3374	1-220-168-81	METAL CHIP 62	5% 1/16W	R3601	1-218-929-11	METAL CHIP 10	5% 1/16W
R3376	1-218-973-11	METAL CHIP 47K	5% 1/16W	R3602	1-218-990-81	SHORT CHIP 0	
R3377	1-218-973-11	METAL CHIP 47K	5% 1/16W	R3606	1-216-864-11	SHORT CHIP 0	
R3380	1-218-953-11	METAL CHIP 1K	5% 1/16W	R3611	1-218-945-11	METAL CHIP 220	5% 1/16W
R3386	1-218-956-11	METAL CHIP 1.8K	5% 1/16W	R3612	1-218-945-11	METAL CHIP 220	5% 1/16W
R3387	1-218-956-11	METAL CHIP 1.8K	5% 1/16W	R3613	1-218-945-11	METAL CHIP 220	5% 1/16W
R3502	1-218-990-81	SHORT CHIP 0		R3615	1-218-945-11	METAL CHIP 220	5% 1/16W
R3503	1-218-990-81	SHORT CHIP 0		R3616	1-218-937-11	METAL CHIP 47	5% 1/16W
R3504	1-218-990-81	SHORT CHIP 0		R3618	1-218-945-11	METAL CHIP 220	5% 1/16W
R3505	1-218-990-81	SHORT CHIP 0		R3619	1-216-864-11	SHORT CHIP 0	
R3506	1-218-990-81	SHORT CHIP 0		R3620	1-218-941-81	METAL CHIP 100	5% 1/16W
R3507	1-218-990-81	SHORT CHIP 0		R3621	1-218-941-81	METAL CHIP 100	5% 1/16W
R3508	1-218-990-81	SHORT CHIP 0		R3622	1-216-864-11	SHORT CHIP 0	
R3509	1-218-990-81	SHORT CHIP 0		R3623	1-218-941-81	METAL CHIP 100	5% 1/16W
R3510	1-218-933-11	METAL CHIP 22	5% 1/16W	R3624	1-220-208-81	METAL CHIP 130K	5% 1/16W
R3513	1-218-933-11	METAL CHIP 22	5% 1/16W	R3625	1-218-941-81	METAL CHIP 100	5% 1/16W
R3514	1-218-933-11	METAL CHIP 22	5% 1/16W	R3626	1-218-941-81	METAL CHIP 100	5% 1/16W
R3515	1-218-933-11	METAL CHIP 22	5% 1/16W	R3627	1-218-941-81	METAL CHIP 100	5% 1/16W
R3516	1-218-933-11	METAL CHIP 22	5% 1/16W	R3628	1-218-929-11	METAL CHIP 10	5% 1/16W
R3517	1-218-933-11	METAL CHIP 22	5% 1/16W	R3629	1-218-941-81	METAL CHIP 100	5% 1/16W
R3518	1-218-933-11	METAL CHIP 22	5% 1/16W	R3630	1-218-990-81	SHORT CHIP 0	
R3519	1-218-933-11	METAL CHIP 22	5% 1/16W	R3632	1-216-864-11	SHORT CHIP 0	
				R3636	1-218-990-81	SHORT CHIP 0	
				R3637	1-218-937-11	METAL CHIP 47	5% 1/16W
				R3640	1-216-864-11	SHORT CHIP 0	
				R3643	1-216-864-11	SHORT CHIP 0	
				R3644	1-216-864-11	SHORT CHIP 0	

Note: IC3514 on the HDMI board cannot exchange with single.
When this part on the HDMI board is damaged, exchange the entire mounted board.

HDMI	HEADPHONE	MAIN
------	-----------	------

Ref. No.	Part No.	Description	Remark	Ref. No.	Part No.	Description	Remark
R3645	1-216-864-11	SHORT CHIP	0	C014	1-118-695-91	CERAMIC CHIP	0.01uF 5% 50V
R3646	1-216-864-11	SHORT CHIP	0	C015	1-118-695-91	CERAMIC CHIP	0.01uF 5% 50V
R3647	1-208-895-81	METAL CHIP	2.2K 0.5%	C016	1-118-695-91	CERAMIC CHIP	0.01uF 5% 50V
R3648	1-208-695-11	METAL CHIP	3.3K 0.5%				(DH750)
R3804	1-218-937-11	METAL CHIP	47 5%	C017	1-118-695-91	CERAMIC CHIP	0.01uF 5% 50V
R3816	1-218-965-11	METAL CHIP	10K 5%				(DH750)
R3817	1-218-941-81	METAL CHIP	100 5%	C018	1-118-695-91	CERAMIC CHIP	0.01uF 5% 50V
R3826	1-218-990-81	SHORT CHIP	0	C051	1-118-291-11	CERAMIC CHIP	100PF 5% 50V
R3827	1-218-990-81	SHORT CHIP	0	C052	1-118-291-11	CERAMIC CHIP	100PF 5% 50V
R3828	1-218-965-11	METAL CHIP	10K 5%	C053	1-118-291-11	CERAMIC CHIP	100PF 5% 50V
R3829	1-220-212-11	METAL CHIP	300K 5%	C057	1-118-291-11	CERAMIC CHIP	100PF 5% 50V
R3831	1-218-941-81	METAL CHIP	100 5%	C062	1-100-153-91	CERAMIC CHIP	220PF 5% 100V
R3832	1-218-965-11	METAL CHIP	10K 5%	C063	1-100-153-91	CERAMIC CHIP	220PF 5% 100V
R3833	1-208-923-11	METAL CHIP	33K 0.5%	C064	1-100-153-91	CERAMIC CHIP	220PF 5% 100V
R3834	1-208-911-11	METAL CHIP	10K 0.5%	C065	1-100-153-91	CERAMIC CHIP	220PF 5% 100V
R3835	1-208-715-11	METAL CHIP	22K 0.5%	C066	1-100-153-91	CERAMIC CHIP	220PF 5% 100V
R3836	1-218-965-11	METAL CHIP	10K 5%				(DH750)
R3837	1-218-941-81	METAL CHIP	100 5%	C067	1-100-153-91	CERAMIC CHIP	220PF 5% 100V
R3840	1-218-990-81	SHORT CHIP	0				(DH750)
R3842	1-218-973-11	METAL CHIP	47K 5%	C068	1-100-153-91	CERAMIC CHIP	220PF 5% 100V
R3843	1-218-990-81	SHORT CHIP	0	C200	1-118-361-11	CERAMIC CHIP	0.1uF 10% 50V
R3844	1-216-295-91	SHORT CHIP	0	C201	1-116-405-11	CERAMIC CHIP	0.01uF 10% 100V
R3845	1-208-911-11	METAL CHIP	10K 0.5%	C202	1-116-405-11	CERAMIC CHIP	0.01uF 10% 100V
R3846	1-208-911-11	METAL CHIP	10K 0.5%	C203	1-118-361-11	CERAMIC CHIP	0.1uF 10% 50V
R3848	1-218-990-81	SHORT CHIP	0	C204	1-118-361-11	CERAMIC CHIP	0.1uF 10% 50V
R3849	1-218-990-81	SHORT CHIP	0	C205	1-118-361-11	CERAMIC CHIP	0.1uF 10% 50V
R3850	1-218-990-81	SHORT CHIP	0	C206	1-118-435-11	CERAMIC CHIP	47PF 5% 50V
		< COMPOSITION CIRCUIT BLOCK >		C207	1-118-361-11	CERAMIC CHIP	0.1uF 10% 50V
RB3204	1-234-400-21	CONDUCTOR, NETWORK (1005X4)		C208	1-118-435-11	CERAMIC CHIP	47PF 5% 50V
RB3205	1-234-400-21	CONDUCTOR, NETWORK (1005X4)		C210	1-126-916-11	ELECT	1000uF 20% 6.3V
		< VIBRATOR >		C211	1-126-947-11	ELECT	47uF 20% 35V
X3001	1-814-595-11	QUARTS CRYSTAL UNIT (27MHz)		C250	1-118-361-11	CERAMIC CHIP	0.1uF 10% 50V
		*****		C301	1-126-964-11	ELECT	10uF 20% 50V
		HEADPHONE BOARD		C320	1-126-923-91	ELECT	220uF 20% 10V
		*****		C322	1-118-695-91	CERAMIC CHIP	0.01uF 5% 50V
		< CAPACITOR >		C323	1-126-923-91	ELECT	220uF 20% 10V
C160	1-118-290-11	CERAMIC CHIP	0.001uF 10% 50V	C325	1-126-964-11	ELECT	10uF 20% 50V
C161	1-118-290-11	CERAMIC CHIP	0.001uF 10% 50V	C350	1-118-044-11	CERAMIC CHIP	1uF 10% 50V
C162	1-118-290-11	CERAMIC CHIP	0.001uF 10% 50V	C351	1-126-933-11	ELECT	100uF 20% 16V
		< JACK >		C352	1-118-044-11	CERAMIC CHIP	1uF 10% 50V
J101	1-822-967-12	JACK (PHONES)		C353	1-126-933-11	ELECT	100uF 20% 16V
		*****		C354	1-100-155-91	CERAMIC CHIP	470PF 5% 100V
A-1988-674-A		MAIN BOARD, COMPLETE (DH750)		C355	1-100-155-91	CERAMIC CHIP	470PF 5% 100V
A-1989-623-A		MAIN BOARD, COMPLETE (DH550)		C430	1-165-908-11	CERAMIC CHIP	1uF 10% 10V
		*****					(DH750)
7-685-646-71		SCREW +BVTP 3X8 TYPE2 IT-3		C431	1-165-908-11	CERAMIC CHIP	1uF 10% 10V
		< CAPACITOR >					(DH750)
C001	1-118-291-11	CERAMIC CHIP	100PF 5% 50V	C432	1-118-435-11	CERAMIC CHIP	47PF 5% 50V
C002	1-118-291-11	CERAMIC CHIP	100PF 5% 50V				(DH750)
C003	1-118-291-11	CERAMIC CHIP	100PF 5% 50V	* C433	1-116-720-11	CERAMIC CHIP	10uF 20% 6.3V
C007	1-118-291-11	CERAMIC CHIP	100PF 5% 50V				(DH750)
C012	1-118-695-91	CERAMIC CHIP	0.01uF 5% 50V	C434	1-118-435-11	CERAMIC CHIP	47PF 5% 50V
C013	1-118-695-91	CERAMIC CHIP	0.01uF 5% 50V				(DH750)
				C441	1-118-361-11	CERAMIC CHIP	0.1uF 10% 50V
							(DH750)
				C449	1-118-291-11	CERAMIC CHIP	100PF 5% 50V
				C450	1-118-291-11	CERAMIC CHIP	100PF 5% 50V
				C480	1-165-908-11	CERAMIC CHIP	1uF 10% 10V
							(DH750)
				C481	1-165-908-11	CERAMIC CHIP	1uF 10% 10V
							(DH750)

STR-DH550/DH750

MAIN

Ref. No.	Part No.	Description	Remark	Ref. No.	Part No.	Description	Remark
C482	1-118-435-11	CERAMIC CHIP	47PF 5% 50V (DH750)	C685	1-114-128-91	CERAMIC CHIP	47PF 5% 100V
* C483	1-116-720-11	CERAMIC CHIP	10uF 20% 6.3V (DH750)	C686	1-114-128-91	CERAMIC CHIP	47PF 5% 100V
C484	1-118-435-11	CERAMIC CHIP	47PF 5% 50V (DH750)	C691	1-114-128-91	CERAMIC CHIP	47PF 5% 100V
C487	1-118-361-11	CERAMIC CHIP	0.1uF 10% 50V	C692	1-114-128-91	CERAMIC CHIP	47PF 5% 100V
C489	1-116-173-91	CERAMIC CHIP	0.0022uF 5% 50V	C701	1-164-230-11	CERAMIC CHIP	220PF 5% 50V
C491	1-118-361-11	CERAMIC CHIP	0.1uF 10% 50V (DH750)	C703	1-126-964-11	ELECT	10uF 20% 50V
C499	1-116-173-91	CERAMIC CHIP	0.0022uF 5% 50V	C704	1-118-695-91	CERAMIC CHIP	0.01uF 5% 50V
C503	1-126-964-11	ELECT	10uF 20% 50V	C705	1-114-339-91	CERAMIC CHIP	3300PF 5% 50V
C505	1-114-339-91	CERAMIC CHIP	3300PF 5% 50V	C708	1-126-947-11	ELECT	47uF 20% 35V
C545	1-126-947-11	ELECT	47uF 20% 35V	C710	1-126-964-11	ELECT	10uF 20% 50V
C546	1-126-964-11	ELECT	10uF 20% 50V	C712	1-118-291-11	CERAMIC CHIP	100PF 5% 50V
C547	1-126-964-11	ELECT	10uF 20% 50V	C713	1-126-923-91	ELECT	220uF 20% 10V
C548	1-118-361-11	CERAMIC CHIP	0.1uF 10% 50V	C720	1-114-339-91	CERAMIC CHIP	3300PF 5% 50V
C551	1-164-230-11	CERAMIC CHIP	220PF 5% 50V	C728	1-114-324-11	CERAMIC CHIP	0.022uF 10% 50V
C553	1-126-964-11	ELECT	10uF 20% 50V	C731	1-116-138-11	CERAMIC CHIP	4PF 0.25PF 100V
C554	1-118-695-91	CERAMIC CHIP	0.01uF 5% 50V	C732	1-116-138-11	CERAMIC CHIP	4PF 0.25PF 100V
C555	1-114-339-91	CERAMIC CHIP	3300PF 5% 50V	C735	1-114-128-91	CERAMIC CHIP	47PF 5% 100V
C558	1-126-947-11	ELECT	47uF 20% 35V	C736	1-114-128-91	CERAMIC CHIP	47PF 5% 100V
C560	1-126-964-11	ELECT	10uF 20% 50V	C741	1-114-128-91	CERAMIC CHIP	47PF 5% 100V
C563	1-126-923-91	ELECT	220uF 20% 10V	C742	1-114-128-91	CERAMIC CHIP	47PF 5% 100V
C564	1-118-291-11	CERAMIC CHIP	100PF 5% 50V	C751	1-164-230-11	CERAMIC CHIP	220PF 5% 50V
C570	1-114-339-91	CERAMIC CHIP	3300PF 5% 50V	C753	1-126-964-11	ELECT	10uF 20% 50V
C578	1-114-324-11	CERAMIC CHIP	0.022uF 10% 50V	C754	1-118-695-91	CERAMIC CHIP	0.01uF 5% 50V
C581	1-116-138-11	CERAMIC CHIP	4PF 0.25PF 100V	C755	1-114-339-91	CERAMIC CHIP	3300PF 5% 50V
C582	1-116-138-11	CERAMIC CHIP	4PF 0.25PF 100V	C758	1-126-947-11	ELECT	47uF 20% 35V
C585	1-114-128-91	CERAMIC CHIP	47PF 5% 100V	C760	1-126-964-11	ELECT	10uF 20% 50V
C586	1-114-128-91	CERAMIC CHIP	47PF 5% 100V	C762	1-118-291-11	CERAMIC CHIP	100PF 5% 50V
C591	1-114-128-91	CERAMIC CHIP	47PF 5% 100V	C763	1-126-923-91	ELECT	220uF 20% 10V
C592	1-114-128-91	CERAMIC CHIP	47PF 5% 100V	C770	1-114-339-91	CERAMIC CHIP	3300PF 5% 50V
C601	1-164-230-11	CERAMIC CHIP	220PF 5% 50V	C778	1-114-324-11	CERAMIC CHIP	0.022uF 10% 50V
C603	1-126-964-11	ELECT	10uF 20% 50V	C781	1-116-138-11	CERAMIC CHIP	4PF 0.25PF 100V
C604	1-118-695-91	CERAMIC CHIP	0.01uF 5% 50V	C782	1-116-138-11	CERAMIC CHIP	4PF 0.25PF 100V
C605	1-114-339-91	CERAMIC CHIP	3300PF 5% 50V	C785	1-114-128-91	CERAMIC CHIP	47PF 5% 100V
C610	1-126-964-11	ELECT	10uF 20% 50V	C786	1-114-128-91	CERAMIC CHIP	47PF 5% 100V
C612	1-118-291-11	CERAMIC CHIP	100PF 5% 50V	C791	1-114-128-91	CERAMIC CHIP	47PF 5% 100V
C613	1-126-923-91	ELECT	220uF 20% 10V	C792	1-114-128-91	CERAMIC CHIP	47PF 5% 100V
C618	1-126-947-11	ELECT	47uF 20% 35V	C801	1-164-230-11	CERAMIC CHIP	220PF 5% 50V
C620	1-114-339-91	CERAMIC CHIP	3300PF 5% 50V	C803	1-126-964-11	ELECT	10uF 20% 50V (DH750)
C628	1-114-324-11	CERAMIC CHIP	0.022uF 10% 50V	C804	1-118-695-91	CERAMIC CHIP	0.01uF 5% 50V (DH750)
C631	1-116-138-11	CERAMIC CHIP	4PF 0.25PF 100V	C805	1-114-339-91	CERAMIC CHIP	3300PF 5% 50V (DH750)
C632	1-116-138-11	CERAMIC CHIP	4PF 0.25PF 100V	C808	1-126-947-11	ELECT	47uF 20% 35V (DH750)
C635	1-114-128-91	CERAMIC CHIP	47PF 5% 100V	C810	1-126-964-11	ELECT	10uF 20% 50V (DH750)
C636	1-114-128-91	CERAMIC CHIP	47PF 5% 100V	C812	1-118-291-11	CERAMIC CHIP	100PF 5% 50V (DH750)
C641	1-114-128-91	CERAMIC CHIP	47PF 5% 100V	C813	1-126-923-91	ELECT	220uF 20% 10V (DH750)
C642	1-114-128-91	CERAMIC CHIP	47PF 5% 100V	C820	1-114-339-91	CERAMIC CHIP	3300PF 5% 50V (DH750)
C651	1-164-230-11	CERAMIC CHIP	220PF 5% 50V	C828	1-114-324-11	CERAMIC CHIP	0.022uF 10% 50V (DH750)
C653	1-126-964-11	ELECT	10uF 20% 50V	C831	1-116-138-11	CERAMIC CHIP	4PF 0.25PF 100V (DH750)
C654	1-118-695-91	CERAMIC CHIP	0.01uF 5% 50V	C832	1-116-138-11	CERAMIC CHIP	4PF 0.25PF 100V (DH750)
C655	1-114-339-91	CERAMIC CHIP	3300PF 5% 50V	C835	1-114-128-91	CERAMIC CHIP	47PF 5% 100V (DH750)
C658	1-126-947-11	ELECT	47uF 20% 35V				
C660	1-126-964-11	ELECT	10uF 20% 50V				
C662	1-118-291-11	CERAMIC CHIP	100PF 5% 50V				
C663	1-126-923-91	ELECT	220uF 20% 10V				
C670	1-114-339-91	CERAMIC CHIP	3300PF 5% 50V				
C678	1-114-324-11	CERAMIC CHIP	0.022uF 10% 50V				
C681	1-116-138-11	CERAMIC CHIP	4PF 0.25PF 100V				
C682	1-116-138-11	CERAMIC CHIP	4PF 0.25PF 100V				

Ref. No.	Part No.	Description	Remark	Ref. No.	Part No.	Description	Remark
C836	1-114-128-91	CERAMIC CHIP 47PF	5% 100V (DH750)	C2039	1-118-386-11	CERAMIC CHIP 0.1uF	10% 16V
C841	1-114-128-91	CERAMIC CHIP 47PF	5% 100V (DH750)	C2040	1-118-386-11	CERAMIC CHIP 0.1uF	10% 16V
C842	1-114-128-91	CERAMIC CHIP 47PF	5% 100V (DH750)	C2041	1-125-777-11	CERAMIC CHIP 0.1uF	10% 10V
C851	1-164-230-11	CERAMIC CHIP 220PF	5% 50V (DH750)	C2042	1-118-386-11	CERAMIC CHIP 0.1uF	10% 16V
C853	1-126-964-11	ELECT 10uF	20% 50V (DH750)	C2043	1-118-386-11	CERAMIC CHIP 0.1uF	10% 16V
C854	1-118-695-91	CERAMIC CHIP 0.01uF	5% 50V (DH750)	C2044	1-118-290-11	CERAMIC CHIP 0.001uF	10% 50V
C855	1-114-339-91	CERAMIC CHIP 3300PF	5% 50V (DH750)	C2045	1-118-361-11	CERAMIC CHIP 0.1uF	10% 50V
C858	1-126-947-11	ELECT 47uF	20% 35V (DH750)	C2046	1-118-361-11	CERAMIC CHIP 0.1uF	10% 50V
C860	1-126-964-11	ELECT 10uF	20% 50V (DH750)	C2047	1-118-361-11	CERAMIC CHIP 0.1uF	10% 50V
C862	1-118-291-11	CERAMIC CHIP 100PF	5% 50V (DH750)	C2065	1-118-290-11	CERAMIC CHIP 0.001uF	10% 50V
C863	1-126-923-91	ELECT 220uF	20% 10V (DH750)	C2066	1-116-724-11	CERAMIC CHIP 4.7uF	20% 6.3V
C870	1-114-339-91	CERAMIC CHIP 3300PF	5% 50V (DH750)	* C2067	1-116-723-11	CERAMIC CHIP 4.7uF	10% 10V
C878	1-114-324-11	CERAMIC CHIP 0.022uF	10% 50V (DH750)	* C2068	1-118-035-11	CERAMIC CHIP 0.1uF	10% 25V
C881	1-116-138-11	CERAMIC CHIP 4PF	0.25PF 100V (DH750)	C2069	1-125-777-11	CERAMIC CHIP 0.1uF	10% 10V
C882	1-116-138-11	CERAMIC CHIP 4PF	0.25PF 100V (DH750)	C2073	1-118-361-11	CERAMIC CHIP 0.1uF	10% 50V
C885	1-114-128-91	CERAMIC CHIP 47PF	5% 100V (DH750)	C2078	1-125-777-11	CERAMIC CHIP 0.1uF	10% 10V
C886	1-114-128-91	CERAMIC CHIP 47PF	5% 100V (DH750)	C2088	1-125-777-11	CERAMIC CHIP 0.1uF	10% 10V
C891	1-114-128-91	CERAMIC CHIP 47PF	5% 100V (DH750)	C2200	1-164-847-11	CERAMIC CHIP 7PF	0.5PF 50V
C892	1-114-128-91	CERAMIC CHIP 47PF	5% 100V (DH750)	C2202	1-104-658-91	ELECT 100uF	20% 10V
C910	1-118-361-11	CERAMIC CHIP 0.1uF	10% 50V	C2203	1-125-777-11	CERAMIC CHIP 0.1uF	10% 10V
C911	1-118-361-11	CERAMIC CHIP 0.1uF	10% 50V	C2204	1-125-777-11	CERAMIC CHIP 0.1uF	10% 10V
C912	1-126-943-11	ELECT 2200uF	20% 25V	C2205	1-164-847-11	CERAMIC CHIP 7PF	0.5PF 50V
C913	1-126-942-61	ELECT 1000uF	20% 25V	C2206	1-104-662-91	ELECT 22uF	20% 25V
C930	1-165-946-11	ELECT (BLOCK) 6800uF	20% 71V	C2207	1-125-777-11	CERAMIC CHIP 0.1uF	10% 10V
C931	1-165-946-11	ELECT (BLOCK) 6800uF	20% 71V	C2208	1-100-155-91	CERAMIC CHIP 470PF	5% 100V
C934	1-100-623-91	CERAMIC CHIP 0.1uF	10% 100V	* C2209	1-116-720-11	CERAMIC CHIP 10uF	20% 6.3V
C935	1-100-623-91	CERAMIC CHIP 0.1uF	10% 100V	C2210	1-125-777-11	CERAMIC CHIP 0.1uF	10% 10V
C984	1-116-173-91	CERAMIC CHIP 0.0022uF	5% 50V	C2213	1-125-777-11	CERAMIC CHIP 0.1uF	10% 10V
C987	1-128-560-11	ELECT 22uF	20% 100V	C2214	1-125-777-11	CERAMIC CHIP 0.1uF	10% 10V
C988	1-128-560-11	ELECT 22uF	20% 100V	C2215	1-104-658-91	ELECT 100uF	20% 10V
C2008	1-126-947-11	ELECT 47uF	20% 35V	C2218	1-118-347-11	CERAMIC CHIP 0.1uF	10% 25V
* C2009	1-116-723-11	CERAMIC CHIP 4.7uF	10% 10V	C2219	1-125-777-11	CERAMIC CHIP 0.1uF	10% 10V
C2011	1-118-361-11	CERAMIC CHIP 0.1uF	10% 50V	C2220	1-126-933-11	ELECT 100uF	20% 16V
* C2012	1-118-035-11	CERAMIC CHIP 0.1uF	10% 25V	C2221	1-137-987-81	CERAMIC CHIP 0.068uF	10% 10V
C2016	1-125-777-11	CERAMIC CHIP 0.1uF	10% 10V	C2222	1-126-933-11	ELECT 100uF	20% 16V
C2024	1-125-777-11	CERAMIC CHIP 0.1uF	10% 10V	C2223	1-118-403-11	CERAMIC CHIP 0.001uF	10% 50V
C2025	1-125-777-11	CERAMIC CHIP 0.1uF	10% 10V	C2224	1-125-777-11	CERAMIC CHIP 0.1uF	10% 10V
* C2026	1-116-723-11	CERAMIC CHIP 4.7uF	10% 10V	C2225	1-125-777-11	CERAMIC CHIP 0.1uF	10% 10V
C2027	1-118-044-11	CERAMIC CHIP 1uF	10% 50V	C2226	1-125-777-11	CERAMIC CHIP 0.1uF	10% 10V
C2029	1-164-874-11	CERAMIC CHIP 100PF	5% 50V	C2227	1-118-403-11	CERAMIC CHIP 0.001uF	10% 50V
C2033	1-164-874-11	CERAMIC CHIP 100PF	5% 50V	* C2228	1-118-035-11	CERAMIC CHIP 0.1uF	10% 25V
C2034	1-118-386-11	CERAMIC CHIP 0.1uF	10% 16V	C2229	1-125-777-11	CERAMIC CHIP 0.1uF	10% 10V
C2037	1-118-361-11	CERAMIC CHIP 0.1uF	10% 50V	C2302	1-125-777-11	CERAMIC CHIP 0.1uF	10% 10V
* C2038	1-118-035-11	CERAMIC CHIP 0.1uF	10% 25V	C2303	1-118-044-11	CERAMIC CHIP 1uF	10% 50V
				* C2306	1-116-723-11	CERAMIC CHIP 4.7uF	10% 10V
				C2307	1-118-036-11	CERAMIC CHIP 0.1uF	10% 50V
				C2308	1-104-658-91	ELECT 100uF	20% 10V
				C2309	1-118-695-91	CERAMIC CHIP 0.01uF	5% 50V
				* C2310	1-118-035-11	CERAMIC CHIP 0.1uF	10% 25V
				C2311	1-118-459-11	CERAMIC CHIP 0.01uF	10% 25V
				C2312	1-126-933-11	ELECT 100uF	20% 16V
				C2313	1-118-403-11	CERAMIC CHIP 0.001uF	10% 50V
				C2314	1-118-459-11	CERAMIC CHIP 0.01uF	10% 25V
				C2315	1-126-933-11	ELECT 100uF	20% 16V
				C2316	1-118-403-11	CERAMIC CHIP 0.001uF	10% 50V
				* C2317	1-118-035-11	CERAMIC CHIP 0.1uF	10% 25V
				* C2318	1-118-035-11	CERAMIC CHIP 0.1uF	10% 25V
				C2319	1-118-459-11	CERAMIC CHIP 0.01uF	10% 25V
				* C2320	1-118-035-11	CERAMIC CHIP 0.1uF	10% 25V
				C2321	1-126-933-11	ELECT 100uF	20% 16V

Ref. No.	Part No.	Description	Remark	Ref. No.	Part No.	Description	Remark
CN2004	1-820-125-51	CONNECTOR, FFC/FPC 29P		D2200	6-502-961-01	DI DA2J10100L	
CN2600	1-815-762-31	CONNECTOR, FFC/FPC (LIF) 14P (DH750)		D2201	6-502-961-01	DI DA2J10100L	
CN2601	1-784-859-51	CONNECTOR, FFC (LIF (NON-ZIF)) 7P		D2302	6-502-961-01	DI DA2J10100L	
CN2900	1-843-886-11	PIN, CONNECTOR (PC BOARD) 5P		D2303	6-500-514-01	DIODE BAV70	
		< DIODE >		D2304	6-500-514-01	DIODE BAV70	
D301	6-502-961-01	DI DA2J10100L		D2600	6-503-738-01	DI CES521	
D326	6-500-514-01	DIODE BAV70		D2601	6-503-738-01	DI CES521	
D327	6-500-514-01	DIODE BAV70		D2602	6-503-738-01	DI CES521	
D350	6-502-961-01	DI DA2J10100L		D2603	6-503-738-01	DI CES521	
D352	8-719-053-18	DIODE 1SR154-400TE-25		D2604	6-503-738-01	DI CES521	
D355	6-502-961-01	DI DA2J10100L		D2900	1-811-155-11	ELEMENT, ESD PROTECT	
D356	6-504-052-01	DI P6SMB30AT3G		D2901	1-811-155-11	ELEMENT, ESD PROTECT	
D360	6-502-961-01	DI DA2J10100L (DH750)		D2902	6-503-738-01	DI CES521	
D365	6-502-961-01	DI DA2J10100L				< EARTH TERMINAL >	
D536	6-503-015-01	DI DZ2J051M0L		* ET301	1-780-408-11	TERMINAL, LUG	
D550	6-502-961-01	DI DA2J10100L				< FUSE >	
D551	6-502-961-01	DI DA2J10100L		△ F910	1-523-085-11	FUSE (2.5A/250V)	
D570	6-502-961-01	DI DA2J10100L		△ F911	1-523-085-11	FUSE (2.5A/250V)	
D571	6-502-961-01	DI DA2J10100L		△ F912	1-523-080-11	FUSE (6.3A/250V)	
D572	6-502-961-01	DI DA2J10100L		△ F913	1-523-080-11	FUSE (6.3A/250V)	
D600	6-502-961-01	DI DA2J10100L				< FERRITE BEAD >	
D601	6-502-961-01	DI DA2J10100L		FB200	1-400-862-11	BEAD, FERRITE	
D620	6-502-961-01	DI DA2J10100L		FB2000	1-216-864-11	SHORT CHIP 0	
D621	6-502-961-01	DI DA2J10100L		FB2003	1-400-862-11	BEAD, FERRITE	
D622	6-502-961-01	DI DA2J10100L		FB2004	1-400-862-11	BEAD, FERRITE	
D650	6-502-961-01	DI DA2J10100L		FB2011	1-400-862-11	BEAD, FERRITE	
D651	6-502-961-01	DI DA2J10100L		FB2200	1-500-445-21	FERRITE, EMI (SMD) (2012)	
D670	6-502-961-01	DI DA2J10100L		FB2201	1-500-445-21	FERRITE, EMI (SMD) (2012)	
D671	6-502-961-01	DI DA2J10100L		FB2202	1-469-139-21	FERRITE, EMI (SMD) (2012)	
D672	6-502-961-01	DI DA2J10100L		FB2203	1-469-125-21	FERRITE, EMI (SMD) (1608)	
D700	6-502-961-01	DI DA2J10100L		FB2204	1-400-862-11	BEAD, FERRITE	
D701	6-502-961-01	DI DA2J10100L		FB2205	1-500-445-21	FERRITE, EMI (SMD) (2012)	
D720	6-502-961-01	DI DA2J10100L		FB2206	1-400-862-11	BEAD, FERRITE	
D721	6-502-961-01	DI DA2J10100L		FB2300	1-400-862-11	BEAD, FERRITE	
D722	6-502-961-01	DI DA2J10100L		FB2301	1-400-862-11	BEAD, FERRITE	
D750	6-502-961-01	DI DA2J10100L		FB2302	1-400-862-11	BEAD, FERRITE	
D751	6-502-961-01	DI DA2J10100L		FB2303	1-400-862-11	BEAD, FERRITE	
D770	6-502-961-01	DI DA2J10100L		FB2400	1-469-139-21	FERRITE, EMI (SMD) (2012)	
D771	6-502-961-01	DI DA2J10100L		FB2401	1-400-862-11	BEAD, FERRITE	
D772	6-502-961-01	DI DA2J10100L		FB2402	1-400-862-11	BEAD, FERRITE	
D800	6-502-961-01	DI DA2J10100L (DH750)		FB2403	1-400-862-11	BEAD, FERRITE	
D801	6-502-961-01	DI DA2J10100L (DH750)		FB2404	1-400-862-11	BEAD, FERRITE	
D820	6-502-961-01	DI DA2J10100L (DH750)		FB2600	1-400-862-11	BEAD, FERRITE (DH750)	
D821	6-502-961-01	DI DA2J10100L (DH750)		FB2601	1-400-862-11	BEAD, FERRITE	
D822	6-502-961-01	DI DA2J10100L (DH750)		FB2602	1-400-862-11	BEAD, FERRITE	
D850	6-502-961-01	DI DA2J10100L (DH750)		FB2900	1-400-862-11	BEAD, FERRITE	
D851	6-502-961-01	DI DA2J10100L (DH750)		FB2901	1-481-218-21	FERRITE, EMI (SMD) (1608)	
D870	6-502-961-01	DI DA2J10100L (DH750)				< IC >	
D871	6-502-961-01	DI DA2J10100L (DH750)		IC200	6-720-355-01	IC NJM41010F1	
D872	6-502-961-01	DI DA2J10100L (DH750)		IC350	6-718-129-01	IC KIA7807AF-RTF/P	
D910	8-719-053-18	DIODE 1SR154-400TE-25		IC352	6-718-108-01	IC KIA7907F-RTF/P	
D911	8-719-053-18	DIODE 1SR154-400TE-25		IC400	6-720-737-01	IC BD34701KS2	
D912	8-719-053-18	DIODE 1SR154-400TE-25		IC402	8-759-274-71	IC NJM4565M (TE2) (DH750)	
D913	8-719-053-18	DIODE 1SR154-400TE-25		IC2000	6-718-999-01	IC MM1839A50NRE	
D920	6-502-961-01	DI DA2J10100L		IC2001	A-1989-870-A	IC MB9AF156NPMC-G-JNK1E2 (for SERVICE)	
D921	8-719-061-07	DIODE D5SBA60-F		IC2008	6-720-177-01	IC BR24T64FJ-WE2	
D937	6-502-961-01	DI DA2J10100L					
D2003	6-503-759-01	DI RB751V40, 115					
D2011	6-503-738-01	DI CES521					
D2012	6-503-738-01	DI CES521					

STR-DH550/DH750

MAIN

Ref. No.	Part No.	Description	Remark
IC2009	6-719-856-01	IC BU4229F-TR	
IC2200	6-600-827-01	IC JSR1124 (OPTICAL (SAT/CATV) (ASSIGNABLE) IN 1)	
IC2201	6-600-827-01	IC JSR1124 (OPTICAL (TV) (ASSIGNABLE) IN 2)	
IC2202	6-709-888-01	IC TC7WHU04FK	
IC2203	6-717-987-11	IC LC89075WA-H	
IC2204	6-718-383-01	IC TC74VHC393FT (ELK)	
IC2205	8-759-680-48	IC TC7WH157FK	
IC2300	6-718-999-01	IC MM1839A50NRE	
IC2301	6-720-530-01	IC PCM1681PWPR	
IC2400	6-718-924-01	IC ADSST-AVR-3045	
IC2401	A-1989-871-A	IC W25Q80BVSSIG (for SERVICE)	
IC2402	(Not supplied)	IC BD00IC0WHFV-GTR	
IC2601	6-719-856-01	IC BU4229F-TR	
IC2602	A-1989-868-A	IC MB9AF156NPMC-G-JNK1E2 (for SERVICE)	
IC2603	6-718-324-01	IC MFI337S3959	
IC2900	6-719-107-01	IC BU94502AMUV	
IC2901	6-717-006-01	IC BD00HC5WEFJ-E2	
IC2902	6-715-164-01	IC TPS2553DBVR < JACK >	
J200	1-843-567-11	JACK, PIN 3P (VIDEO SAT/CATV IN/VIDEO IN/MONITOR OUT)	
J401	1-843-547-11	JACK, PIN 6P (AUDIO SAT/CATV IN L/R /VIDEO IN L/R / SA-CD/CD IN L/R)	
J402	1-843-546-11	JACK, PIN 4P (AUDIO TV IN L/R /SUBWOOFER OUT)	
J2200	1-784-431-11	JACK, PIN 1P (COAXIAL SA-CD/CD (ASSIGNABLE) IN) < JUMPER >	
JC2670	1-216-295-91	SHORT CHIP 0 (DH550) < COIL >	
L550	1-420-872-52	COIL, AIR-CORE	
L600	1-420-872-52	COIL, AIR-CORE	
L650	1-420-872-52	COIL, AIR-CORE	
L700	1-420-872-52	COIL, AIR-CORE	
L750	1-420-872-52	COIL, AIR-CORE	
L800	1-420-872-52	COIL, AIR-CORE (DH750)	
L850	1-420-872-52	COIL, AIR-CORE (DH750) < TRANSISTOR >	
Q200	6-552-936-01	TR LTC014EUBFS8TL	
Q201	6-553-007-01	TR PMG85XP	
Q301	6-553-266-01	TR 2PD601ART	
Q320	6-550-327-01	TR 2SA1514KT146S	
Q321	6-553-266-01	TR 2PD601ART	
Q323	6-550-327-01	TR 2SA1514KT146S	
Q324	6-553-266-01	TR 2PD601ART	
Q325	8-729-271-31	TRANSISTOR 2SC2713-G	
Q350	6-553-266-01	TR 2PD601ART	
Q355	6-553-266-01	TR 2PD601ART	
Q360	6-553-266-01	TR 2PD601ART (DH750)	
Q365	6-553-266-01	TR 2PD601ART	
Q552	8-729-216-22	TRANSISTOR 2SA1162-G	
Q553	8-729-023-22	TRANSISTOR 2SD2114K	
Q554	6-550-327-01	TR 2SA1514KT146S	
Q555	6-550-327-01	TR 2SA1514KT146S	

Ref. No.	Part No.	Description	Remark
Q570	6-550-032-01	TRANSISTOR HN4A06J-GRBL (TE85R)	
Q572	6-553-334-01	TR KTA1024-Y	
Q574	6-553-335-01	TR KTC3206-Y	
Q575	6-553-335-01	TR KTC3206-Y	
Q602	8-729-216-22	TRANSISTOR 2SA1162-G	
Q603	8-729-023-22	TRANSISTOR 2SD2114K	
Q604	6-550-327-01	TR 2SA1514KT146S	
Q605	6-550-327-01	TR 2SA1514KT146S	
Q620	6-550-032-01	TRANSISTOR HN4A06J-GRBL (TE85R)	
Q622	6-553-334-01	TR KTA1024-Y	
Q624	6-553-335-01	TR KTC3206-Y	
Q625	6-553-335-01	TR KTC3206-Y	
Q652	8-729-216-22	TRANSISTOR 2SA1162-G	
Q653	8-729-023-22	TRANSISTOR 2SD2114K	
Q654	6-550-327-01	TR 2SA1514KT146S	
Q655	6-550-327-01	TR 2SA1514KT146S	
Q670	6-550-032-01	TRANSISTOR HN4A06J-GRBL (TE85R)	
Q672	6-553-334-01	TR KTA1024-Y	
Q674	6-553-335-01	TR KTC3206-Y	
Q675	6-553-335-01	TR KTC3206-Y	
Q702	8-729-216-22	TRANSISTOR 2SA1162-G	
Q703	8-729-023-22	TRANSISTOR 2SD2114K	
Q704	6-550-327-01	TR 2SA1514KT146S	
Q705	6-550-327-01	TR 2SA1514KT146S	
Q720	6-550-032-01	TRANSISTOR HN4A06J-GRBL (TE85R)	
Q722	6-553-334-01	TR KTA1024-Y	
Q724	6-553-335-01	TR KTC3206-Y	
Q725	6-553-335-01	TR KTC3206-Y	
Q752	8-729-216-22	TRANSISTOR 2SA1162-G	
Q753	8-729-023-22	TRANSISTOR 2SD2114K	
Q754	6-550-327-01	TR 2SA1514KT146S	
Q755	6-550-327-01	TR 2SA1514KT146S	
Q770	6-550-032-01	TRANSISTOR HN4A06J-GRBL (TE85R)	
Q772	6-553-334-01	TR KTA1024-Y	
Q774	6-553-335-01	TR KTC3206-Y	
Q775	6-553-335-01	TR KTC3206-Y	
Q802	8-729-216-22	TRANSISTOR 2SA1162-G (DH750)	
Q803	8-729-023-22	TRANSISTOR 2SD2114K (DH750)	
Q804	6-550-327-01	TR 2SA1514KT146S (DH750)	
Q805	6-550-327-01	TR 2SA1514KT146S (DH750)	
Q820	6-550-032-01	TRANSISTOR HN4A06J-GRBL (TE85R) (DH750)	
Q822	6-553-334-01	TR KTA1024-Y (DH750)	
Q824	6-553-335-01	TR KTC3206-Y (DH750)	
Q825	6-553-335-01	TR KTC3206-Y (DH750)	
Q852	8-729-216-22	TRANSISTOR 2SA1162-G (DH750)	
Q853	8-729-023-22	TRANSISTOR 2SD2114K (DH750)	
Q854	6-550-327-01	TR 2SA1514KT146S (DH750)	
Q855	6-550-327-01	TR 2SA1514KT146S (DH750)	
Q870	6-550-032-01	TRANSISTOR HN4A06J-GRBL (TE85R) (DH750)	
Q872	6-553-334-01	TR KTA1024-Y (DH750)	
Q874	6-553-335-01	TR KTC3206-Y (DH750)	
Q875	6-553-335-01	TR KTC3206-Y (DH750)	
Q920	6-553-266-01	TR 2PD601ART	
Q929	6-553-266-01	TR 2PD601ART	
Q2000	6-553-358-01	TR 2PB709BSL	
Q2001	6-553-266-01	TR 2PD601ART	
Q2002	6-553-266-01	TR 2PD601ART	
Q2003	6-553-268-01	TR PDTC114ET	
Q2200	6-552-936-01	TR LTC014EUBFS8TL	

Note: IC2402 on the MAIN board cannot exchange with single.
When this part on the MAIN board is damaged, exchange
the entire mounted board.

Ref. No.	Part No.	Description	Remark			Ref. No.	Part No.	Description	Remark		
Q2600	6-553-007-01	TR	PMG85XP (DH750)			R422	1-216-845-11	METAL CHIP	100K	5%	1/10W (DH750)
Q2601	6-552-936-01	TR	LTC014EUBFS8TL								
Q2602	6-552-936-01	TR	LTC014EUBFS8TL								
Q2604	6-553-007-01	TR	PMG85XP (DH750)			R423	1-216-845-11	METAL CHIP	100K	5%	1/10W (DH750)
		< RESISTOR >									
R012	1-249-393-11	CARBON	10	5%	1/4W	R449	1-216-813-11	METAL CHIP	220	5%	1/10W
R013	1-249-393-11	CARBON	10	5%	1/4W	R450	1-216-813-11	METAL CHIP	220	5%	1/10W
R014	1-249-393-11	CARBON	10	5%	1/4W	R451	1-208-437-41	RES-CHIP	1K	2%	1/10W
R015	1-249-393-11	CARBON	10	5%	1/4W	R453	1-208-437-41	RES-CHIP	1K	2%	1/10W
R016	1-249-393-11	CARBON	10	5%	1/4W (DH750)	R457	1-208-437-41	RES-CHIP	1K	2%	1/10W
						R470	1-216-837-11	METAL CHIP	22K	5%	1/10W (DH750)
R017	1-249-393-11	CARBON	10	5%	1/4W (DH750)	R471	1-216-837-11	METAL CHIP	22K	5%	1/10W (DH750)
R018	1-249-393-11	CARBON	10	5%	1/4W	R472	1-216-845-11	METAL CHIP	100K	5%	1/10W (DH750)
R201	1-216-833-11	METAL CHIP	10K	5%	1/10W	R473	1-216-845-11	METAL CHIP	100K	5%	1/10W (DH750)
R203	1-211-990-11	METAL CHIP	75	0.5%	1/10W						
R204	1-211-990-11	METAL CHIP	75	0.5%	1/10W	R531	1-208-437-41	RES-CHIP	1K	2%	1/10W
R205	1-211-990-11	METAL CHIP	75	0.5%	1/10W	R542	1-249-377-11	CARBON	0.47	5%	1/4W
R251	1-218-855-11	METAL CHIP	2.2K	0.5%	1/10W	R543	1-249-377-11	CARBON	0.47	5%	1/4W
R252	1-218-855-11	METAL CHIP	2.2K	0.5%	1/10W	R544	1-216-864-11	SHORT CHIP	0		
R301	1-216-821-11	METAL CHIP	1K	5%	1/10W	R547	1-218-867-11	METAL CHIP	6.8K	0.5%	1/10W
R302	1-249-405-11	CARBON	100	5%	1/4W						
R304	1-216-841-11	METAL CHIP	47K	5%	1/10W	R548	1-216-837-11	METAL CHIP	22K	5%	1/10W
R307	1-216-845-11	METAL CHIP	100K	5%	1/10W	R549	1-216-837-11	METAL CHIP	22K	5%	1/10W
R308	1-216-841-11	METAL CHIP	47K	5%	1/10W	R550	1-249-389-11	CARBON	4.7	5%	1/4W
R309	1-216-821-11	METAL CHIP	1K	5%	1/10W	R551	1-249-393-11	CARBON	10	5%	1/4W
R320	1-216-837-11	METAL CHIP	22K	5%	1/10W	R552	1-216-214-00	RES-CHIP	4.7K	2%	1/8W
R323	1-216-837-11	METAL CHIP	22K	5%	1/10W	R553	1-200-193-11	ENCAPSULATED COMPONENT			
R325	1-218-867-11	METAL CHIP	6.8K	0.5%	1/10W	R554	1-249-405-11	CARBON	100	5%	1/4W
R326	1-216-840-11	METAL CHIP	39K	5%	1/10W	R555	1-218-879-11	METAL CHIP	22K	0.5%	1/10W
R327	1-216-833-11	METAL CHIP	10K	5%	1/10W	R556	1-218-855-11	METAL CHIP	2.2K	0.5%	1/10W
R328	1-216-821-11	METAL CHIP	1K	5%	1/10W	R557	1-216-841-11	METAL CHIP	47K	5%	1/10W
R350	1-216-825-11	METAL CHIP	2.2K	5%	1/10W	R558	1-240-855-91	CARBON	6.2K	5%	1/4W
R351	1-249-399-11	CARBON	33	5%	1/4W	R559	1-216-845-11	METAL CHIP	100K	5%	1/10W
R353	1-216-841-11	METAL CHIP	47K	5%	1/10W	R560	1-208-437-41	RES-CHIP	1K	2%	1/10W
R355	1-216-821-11	METAL CHIP	1K	5%	1/10W	R561	1-216-843-11	METAL CHIP	68K	5%	1/10W
R356	1-249-399-11	CARBON	33	5%	1/4W	R562	1-208-826-11	METAL CHIP	68K	0.5%	1/10W
R358	1-216-841-11	METAL CHIP	47K	5%	1/10W	R563	1-208-445-41	RES-CHIP	2.2K	2%	1/10W
R360	1-216-825-11	METAL CHIP	2.2K	5%	1/10W (DH750)	R564	1-216-835-11	METAL CHIP	15K	5%	1/10W
						R565	1-216-823-11	METAL CHIP	1.5K	5%	1/10W
R361	1-249-399-11	CARBON	33	5%	1/4W (DH750)	R566	1-218-841-11	METAL CHIP	560	0.5%	1/10W
						R567	1-249-405-11	CARBON	100	5%	1/4W
R363	1-216-841-11	METAL CHIP	47K	5%	1/10W (DH750)	R568	1-216-841-11	METAL CHIP	47K	5%	1/10W
						R569	1-216-843-11	METAL CHIP	68K	5%	1/10W
R365	1-249-399-11	CARBON	33	5%	1/4W	R570	1-216-829-11	METAL CHIP	4.7K	5%	1/10W
R366	1-216-841-11	METAL CHIP	47K	5%	1/10W	R571	1-216-829-11	METAL CHIP	4.7K	5%	1/10W
R367	1-216-821-11	METAL CHIP	1K	5%	1/10W	R572	1-216-829-11	METAL CHIP	4.7K	5%	1/10W
R381	1-218-867-11	METAL CHIP	6.8K	0.5%	1/10W	R573	1-216-813-11	METAL CHIP	220	5%	1/10W
R382	1-218-867-11	METAL CHIP	6.8K	0.5%	1/10W	R574	1-216-813-11	METAL CHIP	220	5%	1/10W
R383	1-218-867-11	METAL CHIP	6.8K	0.5%	1/10W	R575	1-216-825-11	METAL CHIP	2.2K	5%	1/10W
R384	1-218-867-11	METAL CHIP	6.8K	0.5%	1/10W	R576	1-216-817-11	METAL CHIP	470	5%	1/10W
R385	1-218-867-11	METAL CHIP	6.8K	0.5%	1/10W	R577	1-216-825-11	METAL CHIP	2.2K	5%	1/10W
R386	1-218-867-11	METAL CHIP	6.8K	0.5%	1/10W	R578	1-216-814-11	METAL CHIP	270	5%	1/10W
R387	1-218-867-11	METAL CHIP	6.8K	0.5%	1/10W	R579	1-216-842-11	METAL CHIP	56K	5%	1/10W
R401	1-208-437-41	RES-CHIP	1K	2%	1/10W	R581	1-208-437-41	RES-CHIP	1K	2%	1/10W
R403	1-208-437-41	RES-CHIP	1K	2%	1/10W	R600	1-249-389-11	CARBON	4.7	5%	1/4W
R407	1-208-437-41	RES-CHIP	1K	2%	1/10W	R601	1-249-393-11	CARBON	10	5%	1/4W
R420	1-216-837-11	METAL CHIP	22K	5%	1/10W (DH750)	R602	1-216-214-00	RES-CHIP	4.7K	2%	1/8W
						R603	1-200-193-11	ENCAPSULATED COMPONENT			
R421	1-216-837-11	METAL CHIP	22K	5%	1/10W (DH750)	R604	1-249-405-11	CARBON	100	5%	1/4W
						R605	1-218-879-11	METAL CHIP	22K	0.5%	1/10W

STR-DH550/DH750

MAIN

Ref. No.	Part No.	Description	Quantity	Percentage	Remark	Ref. No.	Part No.	Description	Quantity	Percentage	Remark
R606	1-218-855-11	METAL CHIP	2.2K	0.5%	1/10W	R704	1-249-405-11	CARBON	100	5%	1/4W
R607	1-216-841-11	METAL CHIP	47K	5%	1/10W	R705	1-218-879-11	METAL CHIP	22K	0.5%	1/10W
R608	1-240-855-91	CARBON	6.2K	5%	1/4W	R706	1-218-855-11	METAL CHIP	2.2K	0.5%	1/10W
R609	1-216-845-11	METAL CHIP	100K	5%	1/10W	R707	1-216-841-11	METAL CHIP	47K	5%	1/10W
R610	1-208-437-41	RES-CHIP	1K	2%	1/10W	R708	1-240-855-91	CARBON	6.2K	5%	1/4W
R611	1-216-843-11	METAL CHIP	68K	5%	1/10W	R709	1-216-845-11	METAL CHIP	100K	5%	1/10W
R612	1-208-826-11	METAL CHIP	68K	0.5%	1/10W	R710	1-208-437-41	RES-CHIP	1K	2%	1/10W
R613	1-208-445-41	RES-CHIP	2.2K	2%	1/10W	R711	1-216-843-11	METAL CHIP	68K	5%	1/10W
R614	1-216-835-11	METAL CHIP	15K	5%	1/10W	R712	1-208-826-11	METAL CHIP	68K	0.5%	1/10W
R615	1-216-823-11	METAL CHIP	1.5K	5%	1/10W	R713	1-208-445-41	RES-CHIP	2.2K	2%	1/10W
R616	1-218-841-11	METAL CHIP	560	0.5%	1/10W	R714	1-216-835-11	METAL CHIP	15K	5%	1/10W
R617	1-249-405-11	CARBON	100	5%	1/4W	R715	1-216-823-11	METAL CHIP	1.5K	5%	1/10W
R618	1-216-841-11	METAL CHIP	47K	5%	1/10W	R716	1-218-841-11	METAL CHIP	560	0.5%	1/10W
R619	1-216-843-11	METAL CHIP	68K	5%	1/10W	R717	1-249-405-11	CARBON	100	5%	1/4W
R620	1-216-829-11	METAL CHIP	4.7K	5%	1/10W	R718	1-216-841-11	METAL CHIP	47K	5%	1/10W
R621	1-216-829-11	METAL CHIP	4.7K	5%	1/10W	R719	1-216-843-11	METAL CHIP	68K	5%	1/10W
R622	1-216-829-11	METAL CHIP	4.7K	5%	1/10W	R720	1-216-829-11	METAL CHIP	4.7K	5%	1/10W
R623	1-216-813-11	METAL CHIP	220	5%	1/10W	R721	1-216-829-11	METAL CHIP	4.7K	5%	1/10W
R624	1-216-813-11	METAL CHIP	220	5%	1/10W	R722	1-216-829-11	METAL CHIP	4.7K	5%	1/10W
R625	1-216-825-11	METAL CHIP	2.2K	5%	1/10W	R723	1-216-813-11	METAL CHIP	220	5%	1/10W
R626	1-216-817-11	METAL CHIP	470	5%	1/10W	R724	1-216-813-11	METAL CHIP	220	5%	1/10W
R627	1-216-825-11	METAL CHIP	2.2K	5%	1/10W	R725	1-216-825-11	METAL CHIP	2.2K	5%	1/10W
R628	1-216-814-11	METAL CHIP	270	5%	1/10W	R726	1-216-817-11	METAL CHIP	470	5%	1/10W
R629	1-216-842-11	METAL CHIP	56K	5%	1/10W	R727	1-216-825-11	METAL CHIP	2.2K	5%	1/10W
R631	1-208-437-41	RES-CHIP	1K	2%	1/10W	R728	1-216-814-11	METAL CHIP	270	5%	1/10W
R650	1-249-389-11	CARBON	4.7	5%	1/4W	R729	1-216-842-11	METAL CHIP	56K	5%	1/10W
R651	1-249-393-11	CARBON	10	5%	1/4W	R731	1-208-437-41	RES-CHIP	1K	2%	1/10W
R652	1-216-214-00	RES-CHIP	4.7K	2%	1/8W	R750	1-249-389-11	CARBON	4.7	5%	1/4W
R653	1-200-193-11	ENCAPSULATED COMPONENT				R751	1-249-393-11	CARBON	10	5%	1/4W
R654	1-249-405-11	CARBON	100	5%	1/4W	R752	1-216-214-00	RES-CHIP	4.7K	2%	1/8W
R655	1-218-879-11	METAL CHIP	22K	0.5%	1/10W	R753	1-200-193-11	ENCAPSULATED COMPONENT			
R656	1-218-855-11	METAL CHIP	2.2K	0.5%	1/10W	R754	1-249-405-11	CARBON	100	5%	1/4W
R657	1-216-841-11	METAL CHIP	47K	5%	1/10W	R755	1-218-879-11	METAL CHIP	22K	0.5%	1/10W
R658	1-240-855-91	CARBON	6.2K	5%	1/4W	R756	1-218-855-11	METAL CHIP	2.2K	0.5%	1/10W
R659	1-216-845-11	METAL CHIP	100K	5%	1/10W	R757	1-216-841-11	METAL CHIP	47K	5%	1/10W
R660	1-208-437-41	RES-CHIP	1K	2%	1/10W	R758	1-240-855-91	CARBON	6.2K	5%	1/4W
R661	1-216-843-11	METAL CHIP	68K	5%	1/10W	R759	1-216-845-11	METAL CHIP	100K	5%	1/10W
R662	1-208-826-11	METAL CHIP	68K	0.5%	1/10W	R760	1-208-437-41	RES-CHIP	1K	2%	1/10W
R663	1-208-445-41	RES-CHIP	2.2K	2%	1/10W	R761	1-216-843-11	METAL CHIP	68K	5%	1/10W
R664	1-216-835-11	METAL CHIP	15K	5%	1/10W	R762	1-208-826-11	METAL CHIP	68K	0.5%	1/10W
R665	1-216-823-11	METAL CHIP	1.5K	5%	1/10W	R763	1-208-445-41	RES-CHIP	2.2K	2%	1/10W
R666	1-218-841-11	METAL CHIP	560	0.5%	1/10W	R764	1-216-835-11	METAL CHIP	15K	5%	1/10W
R667	1-249-405-11	CARBON	100	5%	1/4W	R765	1-216-823-11	METAL CHIP	1.5K	5%	1/10W
R668	1-216-841-11	METAL CHIP	47K	5%	1/10W	R766	1-218-841-11	METAL CHIP	560	0.5%	1/10W
R669	1-216-843-11	METAL CHIP	68K	5%	1/10W	R767	1-249-405-11	CARBON	100	5%	1/4W
R670	1-216-829-11	METAL CHIP	4.7K	5%	1/10W	R768	1-216-841-11	METAL CHIP	47K	5%	1/10W
R671	1-216-829-11	METAL CHIP	4.7K	5%	1/10W	R769	1-216-843-11	METAL CHIP	68K	5%	1/10W
R672	1-216-829-11	METAL CHIP	4.7K	5%	1/10W	R770	1-216-829-11	METAL CHIP	4.7K	5%	1/10W
R673	1-216-813-11	METAL CHIP	220	5%	1/10W	R771	1-216-829-11	METAL CHIP	4.7K	5%	1/10W
R674	1-216-813-11	METAL CHIP	220	5%	1/10W	R772	1-216-829-11	METAL CHIP	4.7K	5%	1/10W
R675	1-216-825-11	METAL CHIP	2.2K	5%	1/10W	R773	1-216-813-11	METAL CHIP	220	5%	1/10W
R676	1-216-817-11	METAL CHIP	470	5%	1/10W	R774	1-216-813-11	METAL CHIP	220	5%	1/10W
R677	1-216-825-11	METAL CHIP	2.2K	5%	1/10W	R775	1-216-825-11	METAL CHIP	2.2K	5%	1/10W
R678	1-216-814-11	METAL CHIP	270	5%	1/10W	R776	1-216-817-11	METAL CHIP	470	5%	1/10W
R679	1-216-842-11	METAL CHIP	56K	5%	1/10W	R777	1-216-825-11	METAL CHIP	2.2K	5%	1/10W
R681	1-208-437-41	RES-CHIP	1K	2%	1/10W	R778	1-216-814-11	METAL CHIP	270	5%	1/10W
R700	1-249-389-11	CARBON	4.7	5%	1/4W	R779	1-216-842-11	METAL CHIP	56K	5%	1/10W
R701	1-249-393-11	CARBON	10	5%	1/4W	R781	1-208-437-41	RES-CHIP	1K	2%	1/10W
R702	1-216-214-00	RES-CHIP	4.7K	2%	1/8W	R800	1-249-389-11	CARBON	4.7	5%	1/4W
R703	1-200-193-11	ENCAPSULATED COMPONENT									(DH750)

Ref. No.	Part No.	Description	Remark	Ref. No.	Part No.	Description	Remark
R801	1-249-393-11	CARBON	10 5%	1/4W (DH750)	R853	1-200-193-11	ENCAPSULATED COMPONENT (DH750)
R802	1-216-214-00	RES-CHIP	4.7K 2%	1/8W (DH750)	R854	1-249-405-11	CARBON 100 5% 1/4W (DH750)
R803	1-200-193-11	ENCAPSULATED COMPONENT (DH750)			R855	1-218-879-11	METAL CHIP 22K 0.5% 1/10W (DH750)
R804	1-249-405-11	CARBON	100 5%	1/4W (DH750)	R856	1-218-855-11	METAL CHIP 2.2K 0.5% 1/10W (DH750)
R805	1-218-879-11	METAL CHIP	22K 0.5%	1/10W (DH750)	R857	1-216-841-11	METAL CHIP 47K 5% 1/10W (DH750)
R806	1-218-855-11	METAL CHIP	2.2K 0.5%	1/10W (DH750)	R858	1-240-855-91	CARBON 6.2K 5% 1/4W (DH750)
R807	1-216-841-11	METAL CHIP	47K 5%	1/10W (DH750)	R859	1-216-845-11	METAL CHIP 100K 5% 1/10W (DH750)
R808	1-240-855-91	CARBON	6.2K 5%	1/4W (DH750)	R860	1-208-437-41	RES-CHIP 1K 2% 1/10W (DH750)
R809	1-216-845-11	METAL CHIP	100K 5%	1/10W (DH750)	R861	1-216-843-11	METAL CHIP 68K 5% 1/10W (DH750)
R810	1-208-437-41	RES-CHIP	1K 2%	1/10W (DH750)	R862	1-208-826-11	METAL CHIP 68K 0.5% 1/10W (DH750)
R811	1-216-843-11	METAL CHIP	68K 5%	1/10W (DH750)	R863	1-208-445-41	RES-CHIP 2.2K 2% 1/10W (DH750)
R812	1-208-826-11	METAL CHIP	68K 0.5%	1/10W (DH750)	R864	1-216-835-11	METAL CHIP 15K 5% 1/10W (DH750)
R813	1-208-445-41	RES-CHIP	2.2K 2%	1/10W (DH750)	R865	1-216-823-11	METAL CHIP 1.5K 5% 1/10W (DH750)
R814	1-216-835-11	METAL CHIP	15K 5%	1/10W (DH750)	R866	1-218-841-11	METAL CHIP 560 0.5% 1/10W (DH750)
R815	1-216-823-11	METAL CHIP	1.5K 5%	1/10W (DH750)	R867	1-249-405-11	CARBON 100 5% 1/4W (DH750)
R816	1-218-841-11	METAL CHIP	560 0.5%	1/10W (DH750)	R868	1-216-841-11	METAL CHIP 47K 5% 1/10W (DH750)
R817	1-249-405-11	CARBON	100 5%	1/4W (DH750)	R869	1-216-843-11	METAL CHIP 68K 5% 1/10W (DH750)
R818	1-216-841-11	METAL CHIP	47K 5%	1/10W (DH750)	R870	1-216-829-11	METAL CHIP 4.7K 5% 1/10W (DH750)
R819	1-216-843-11	METAL CHIP	68K 5%	1/10W (DH750)	R871	1-216-829-11	METAL CHIP 4.7K 5% 1/10W (DH750)
R820	1-216-829-11	METAL CHIP	4.7K 5%	1/10W (DH750)	R872	1-216-829-11	METAL CHIP 4.7K 5% 1/10W (DH750)
R821	1-216-829-11	METAL CHIP	4.7K 5%	1/10W (DH750)	R873	1-216-813-11	METAL CHIP 220 5% 1/10W (DH750)
R822	1-216-829-11	METAL CHIP	4.7K 5%	1/10W (DH750)	R874	1-216-813-11	METAL CHIP 220 5% 1/10W (DH750)
R823	1-216-813-11	METAL CHIP	220 5%	1/10W (DH750)	R875	1-216-825-11	METAL CHIP 2.2K 5% 1/10W (DH750)
R824	1-216-813-11	METAL CHIP	220 5%	1/10W (DH750)	R876	1-216-817-11	METAL CHIP 470 5% 1/10W (DH750)
R825	1-216-825-11	METAL CHIP	2.2K 5%	1/10W (DH750)	R877	1-216-825-11	METAL CHIP 2.2K 5% 1/10W (DH750)
R826	1-216-817-11	METAL CHIP	470 5%	1/10W (DH750)	R878	1-216-814-11	METAL CHIP 270 5% 1/10W (DH750)
R827	1-216-825-11	METAL CHIP	2.2K 5%	1/10W (DH750)	R879	1-216-842-11	METAL CHIP 56K 5% 1/10W (DH750)
R828	1-216-814-11	METAL CHIP	270 5%	1/10W (DH750)	R881	1-208-437-41	RES-CHIP 1K 2% 1/10W (DH750)
R829	1-216-842-11	METAL CHIP	56K 5%	1/10W (DH750)	R920	1-249-399-11	CARBON 33 5% 1/4W
R831	1-208-437-41	RES-CHIP	1K 2%	1/10W (DH750)	R921	1-216-825-11	METAL CHIP 2.2K 5% 1/10W
R850	1-249-389-11	CARBON	4.7 5%	1/4W (DH750)	R925	1-216-841-11	METAL CHIP 47K 5% 1/10W
R851	1-249-393-11	CARBON	10 5%	1/4W (DH750)	R926	1-249-399-11	CARBON 33 5% 1/4W
R852	1-216-214-00	RES-CHIP	4.7K 2%	1/8W (DH750)	R927	1-216-841-11	METAL CHIP 47K 5% 1/10W
					R928	1-216-825-11	METAL CHIP 2.2K 5% 1/10W
					R935	1-208-437-41	RES-CHIP 1K 2% 1/10W
					R936	1-208-437-41	RES-CHIP 1K 2% 1/10W
					R937	1-218-632-11	METAL CHIP 330 5% 1W
					R938	1-218-632-11	METAL CHIP 330 5% 1W

STR-DH550/DH750

MAIN

Ref. No.	Part No.	Description	Quantity	Unit	Remark	Ref. No.	Part No.	Description	Quantity	Unit	Remark
R939	1-218-632-11	METAL CHIP	330	5%	1W	R2203	1-218-933-11	METAL CHIP	22	5%	1/16W
R940	1-218-632-11	METAL CHIP	330	5%	1W	R2204	1-218-933-11	METAL CHIP	22	5%	1/16W
R2000	1-218-937-11	METAL CHIP	47	5%	1/16W	R2205	1-218-933-11	METAL CHIP	22	5%	1/16W
R2001	1-218-947-11	METAL CHIP	330	5%	1/16W	R2206	1-218-941-81	METAL CHIP	100	5%	1/16W
R2002	1-218-951-11	METAL CHIP	680	5%	1/16W	R2209	1-218-989-11	METAL CHIP	1M	5%	1/16W
R2003	1-218-941-81	METAL CHIP	100	5%	1/16W (DH750)	R2210	1-216-833-11	METAL CHIP	10K	5%	1/10W
R2004	1-218-957-11	METAL CHIP	2.2K	5%	1/16W	R2211	1-218-941-81	METAL CHIP	100	5%	1/16W
R2005	1-218-937-11	METAL CHIP	47	5%	1/16W	R2212	1-218-941-81	METAL CHIP	100	5%	1/16W
R2006	1-218-949-11	METAL CHIP	470	5%	1/16W	R2213	1-218-949-11	METAL CHIP	470	5%	1/16W
R2007	1-218-947-11	METAL CHIP	330	5%	1/16W	R2214	1-218-985-11	METAL CHIP	470K	5%	1/16W
R2008	1-218-941-81	METAL CHIP	100	5%	1/16W	R2215	1-216-857-11	METAL CHIP	1M	5%	1/10W
R2009	1-216-833-11	METAL CHIP	10K	5%	1/10W	R2216	1-218-941-81	METAL CHIP	100	5%	1/16W
R2010	1-218-941-81	METAL CHIP	100	5%	1/16W	R2217	1-218-973-11	METAL CHIP	47K	5%	1/16W
R2011	1-216-833-11	METAL CHIP	10K	5%	1/10W	R2218	1-218-953-11	METAL CHIP	1K	5%	1/16W
R2012	1-218-951-11	METAL CHIP	680	5%	1/16W	R2219	1-218-947-11	METAL CHIP	330	5%	1/16W
R2013	1-218-941-81	METAL CHIP	100	5%	1/16W	R2220	1-216-833-11	METAL CHIP	10K	5%	1/10W
R2014	1-218-941-81	METAL CHIP	100	5%	1/16W	R2221	1-216-833-11	METAL CHIP	10K	5%	1/10W
R2015	1-218-941-81	METAL CHIP	100	5%	1/16W	R2222	1-218-945-11	METAL CHIP	220	5%	1/16W
R2016	1-218-961-11	METAL CHIP	4.7K	5%	1/16W	R2223	1-218-945-11	METAL CHIP	220	5%	1/16W
R2017	1-218-941-81	METAL CHIP	100	5%	1/16W	R2224	1-218-990-81	SHORT CHIP	0		
R2018	1-218-941-81	METAL CHIP	100	5%	1/16W	R2225	1-218-965-11	METAL CHIP	10K	5%	1/16W
R2019	1-218-953-11	METAL CHIP	1K	5%	1/16W	R2226	1-218-990-81	SHORT CHIP	0		
R2021	1-218-969-11	METAL CHIP	22K	5%	1/16W	R2227	1-218-990-81	SHORT CHIP	0		
R2022	1-218-969-11	METAL CHIP	22K	5%	1/16W	R2228	1-218-937-11	METAL CHIP	47	5%	1/16W
R2025	1-216-833-11	METAL CHIP	10K	5%	1/10W	R2229	1-218-965-11	METAL CHIP	10K	5%	1/16W
R2026	1-216-833-11	METAL CHIP	10K	5%	1/10W	R2230	1-218-965-11	METAL CHIP	10K	5%	1/16W
R2031	1-216-825-11	METAL CHIP	2.2K	5%	1/10W	R2231	1-218-990-81	SHORT CHIP	0		
R2032	1-216-825-11	METAL CHIP	2.2K	5%	1/10W	R2232	1-218-965-11	METAL CHIP	10K	5%	1/16W
R2037	1-218-970-81	METAL CHIP	27K	5%	1/16W	R2233	1-218-953-11	METAL CHIP	1K	5%	1/16W
R2040	1-218-945-11	METAL CHIP	220	5%	1/16W	R2234	1-218-953-11	METAL CHIP	1K	5%	1/16W
R2041	1-218-953-11	METAL CHIP	1K	5%	1/16W	R2235	1-250-471-11	METAL CHIP	100	1%	1/16W
R2042	1-216-833-11	METAL CHIP	10K	5%	1/10W	R2236	1-218-949-11	METAL CHIP	470	5%	1/16W
R2043	1-218-953-11	METAL CHIP	1K	5%	1/16W	R2237	1-218-941-81	METAL CHIP	100	5%	1/16W
R2046	1-216-825-11	METAL CHIP	2.2K	5%	1/10W	R2238	1-216-864-11	SHORT CHIP	0		
R2050	1-216-825-11	METAL CHIP	2.2K	5%	1/10W	R2239	1-218-941-81	METAL CHIP	100	5%	1/16W
R2058	1-218-941-81	METAL CHIP	100	5%	1/16W	R2300	1-218-971-11	METAL CHIP	33K	5%	1/16W
R2061	1-216-827-11	METAL CHIP	3.3K	5%	1/10W	R2301	1-218-969-11	METAL CHIP	22K	5%	1/16W
R2063	1-216-827-11	METAL CHIP	3.3K	5%	1/10W	R2302	1-216-833-11	METAL CHIP	10K	5%	1/10W
R2064	1-218-957-11	METAL CHIP	2.2K	5%	1/16W	R2303	1-218-941-81	METAL CHIP	100	5%	1/16W (DH750)
R2066	1-218-941-81	METAL CHIP	100	5%	1/16W	R2304	1-218-941-81	METAL CHIP	100	5%	1/16W
R2068	1-218-965-11	METAL CHIP	10K	5%	1/16W	R2305	1-218-941-81	METAL CHIP	100	5%	1/16W
R2075	1-216-833-11	METAL CHIP	10K	5%	1/10W	R2306	1-218-941-81	METAL CHIP	100	5%	1/16W
R2076	1-216-833-11	METAL CHIP	10K	5%	1/10W	R2307	1-216-833-11	METAL CHIP	10K	5%	1/10W
R2077	1-216-833-11	METAL CHIP	10K	5%	1/10W	R2308	1-216-833-11	METAL CHIP	10K	5%	1/10W
R2079	1-216-833-11	METAL CHIP	10K	5%	1/10W	R2309	1-218-965-11	METAL CHIP	10K	5%	1/16W
R2080	1-216-833-11	METAL CHIP	10K	5%	1/10W	R2310	1-216-833-11	METAL CHIP	10K	5%	1/10W
R2081	1-218-941-81	METAL CHIP	100	5%	1/16W	R2400	1-218-941-81	METAL CHIP	100	5%	1/16W
R2083	1-218-941-81	METAL CHIP	100	5%	1/16W (DH750)	R2401	1-218-933-11	METAL CHIP	22	5%	1/16W
R2084	1-216-833-11	METAL CHIP	10K	5%	1/10W	R2402	1-218-945-11	METAL CHIP	220	5%	1/16W
R2085	1-216-833-11	METAL CHIP	10K	5%	1/10W	R2403	1-218-933-11	METAL CHIP	22	5%	1/16W
R2086	1-218-941-81	METAL CHIP	100	5%	1/16W	R2404	1-218-945-11	METAL CHIP	220	5%	1/16W
R2090	1-218-953-11	METAL CHIP	1K	5%	1/16W	R2405	1-218-945-11	METAL CHIP	220	5%	1/16W
R2093	1-216-833-11	METAL CHIP	10K	5%	1/10W	R2406	1-218-965-11	METAL CHIP	10K	5%	1/16W
R2094	1-216-833-11	METAL CHIP	10K	5%	1/10W	R2407	1-218-965-11	METAL CHIP	10K	5%	1/16W
R2100	1-216-833-11	METAL CHIP	10K	5%	1/10W	R2408	1-218-933-11	METAL CHIP	22	5%	1/16W
R2200	1-250-468-11	METAL CHIP	75	1%	1/16W	R2409	1-218-933-11	METAL CHIP	22	5%	1/16W
R2201	1-218-945-11	METAL CHIP	220	5%	1/16W	R2410	1-218-933-11	METAL CHIP	22	5%	1/16W
R2202	1-218-945-11	METAL CHIP	220	5%	1/16W	R2411	1-216-833-11	METAL CHIP	10K	5%	1/10W
						R2412	1-218-933-11	METAL CHIP	22	5%	1/16W

Ref. No.	Part No.	Description	Quantity	Percentage	Remark	Ref. No.	Part No.	Description	Quantity	Percentage	Remark
R2413	1-216-833-11	METAL CHIP	10K	5%	1/10W	R2616	1-218-941-81	METAL CHIP	100	5%	1/16W
R2414	1-218-933-11	METAL CHIP	22	5%	1/16W						(DH750)
R2415	1-218-945-11	METAL CHIP	220	5%	1/16W	R2617	1-218-941-81	METAL CHIP	100	5%	1/16W
R2416	1-218-933-11	METAL CHIP	22	5%	1/16W						(DH750)
R2417	1-218-933-11	METAL CHIP	22	5%	1/16W	R2619	1-218-941-81	METAL CHIP	100	5%	1/16W
R2418	1-218-933-11	METAL CHIP	22	5%	1/16W	R2620	1-218-941-81	METAL CHIP	100	5%	1/16W
R2419	1-218-933-11	METAL CHIP	22	5%	1/16W	R2621	1-218-941-81	METAL CHIP	100	5%	1/16W
R2420	1-218-947-11	METAL CHIP	330	5%	1/16W	R2622	1-218-941-81	METAL CHIP	100	5%	1/16W
R2421	1-218-947-11	METAL CHIP	330	5%	1/16W	R2623	1-218-941-81	METAL CHIP	100	5%	1/16W
R2422	1-218-933-11	METAL CHIP	22	5%	1/16W	R2624	1-216-833-11	METAL CHIP	10K	5%	1/10W
R2423	1-218-953-11	METAL CHIP	1K	5%	1/16W	R2625	1-216-845-11	METAL CHIP	100K	5%	1/10W
R2424	1-218-933-11	METAL CHIP	22	5%	1/16W						(DH750)
R2425	1-218-989-11	METAL CHIP	1M	5%	1/16W	R2626	1-216-845-11	METAL CHIP	100K	5%	1/10W
R2426	1-218-933-11	METAL CHIP	22	5%	1/16W						(DH750)
R2427	1-216-833-11	METAL CHIP	10K	5%	1/10W	R2629	1-216-833-11	METAL CHIP	10K	5%	1/10W
R2429	1-218-941-81	METAL CHIP	100	5%	1/16W	R2630	1-218-941-81	METAL CHIP	100	5%	1/16W
R2430	1-218-933-11	METAL CHIP	22	5%	1/16W						(DH750)
R2431	1-218-941-81	METAL CHIP	100	5%	1/16W	R2631	1-216-833-11	METAL CHIP	10K	5%	1/10W
R2432	1-218-965-11	METAL CHIP	10K	5%	1/16W	R2632	1-218-953-11	METAL CHIP	1K	5%	1/16W
R2434	1-218-965-11	METAL CHIP	10K	5%	1/16W	R2633	1-218-953-11	METAL CHIP	1K	5%	1/16W
R2435	1-218-965-11	METAL CHIP	10K	5%	1/16W	R2634	1-218-941-81	METAL CHIP	100	5%	1/16W
R2436	1-218-933-11	METAL CHIP	22	5%	1/16W	R2636	1-216-833-11	METAL CHIP	10K	5%	1/10W
R2437	1-218-990-81	SHORT CHIP	0			R2637	1-216-833-11	METAL CHIP	10K	5%	1/10W
R2438	1-218-990-81	SHORT CHIP	0			R2638	1-216-825-11	METAL CHIP	2.2K	5%	1/10W
R2439	1-218-933-11	METAL CHIP	22	5%	1/16W	R2639	1-218-941-81	METAL CHIP	100	5%	1/16W
R2440	1-218-933-11	METAL CHIP	22	5%	1/16W	R2640	1-218-941-81	METAL CHIP	100	5%	1/16W
R2441	1-218-933-11	METAL CHIP	22	5%	1/16W	R2642	1-218-937-11	METAL CHIP	47	5%	1/16W
R2442	1-218-965-11	METAL CHIP	10K	5%	1/16W	R2644	1-218-937-11	METAL CHIP	47	5%	1/16W
R2443	1-218-965-11	METAL CHIP	10K	5%	1/16W	R2645	1-218-941-81	METAL CHIP	100	5%	1/16W
R2444	1-218-965-11	METAL CHIP	10K	5%	1/16W	R2646	1-218-941-81	METAL CHIP	100	5%	1/16W
R2445	1-218-957-11	METAL CHIP	2.2K	5%	1/16W	R2647	1-216-833-11	METAL CHIP	10K	5%	1/10W
R2446	1-216-845-11	METAL CHIP	100K	5%	1/10W	R2651	1-218-941-81	METAL CHIP	100	5%	1/16W
R2447	1-218-953-11	METAL CHIP	1K	5%	1/16W	R2652	1-218-941-81	METAL CHIP	100	5%	1/16W
R2448	1-218-933-11	METAL CHIP	22	5%	1/16W	R2653	1-218-965-11	METAL CHIP	10K	5%	1/16W
R2449	1-218-965-11	METAL CHIP	10K	5%	1/16W	R2654	1-218-953-11	METAL CHIP	1K	5%	1/16W
R2450	1-218-933-11	METAL CHIP	22	5%	1/16W	R2655	1-218-953-11	METAL CHIP	1K	5%	1/16W
R2451	1-218-957-11	METAL CHIP	2.2K	5%	1/16W	R2656	1-218-957-11	METAL CHIP	2.2K	5%	1/16W
R2452	1-218-933-11	METAL CHIP	22	5%	1/16W	R2657	1-218-941-81	METAL CHIP	100	5%	1/16W
R2454	1-218-965-11	METAL CHIP	10K	5%	1/16W	R2658	1-218-941-81	METAL CHIP	100	5%	1/16W
R2455	1-208-697-11	METAL CHIP	3.9K	0.5%	1/16W	R2659	1-218-941-81	METAL CHIP	100	5%	1/16W
R2456	1-208-871-81	METAL CHIP	220	0.5%	1/16W	R2660	1-218-937-11	METAL CHIP	47	5%	1/16W
R2457	1-250-519-11	METAL CHIP	10K	1%	1/16W	R2661	1-218-937-11	METAL CHIP	47	5%	1/16W
R2458	1-218-965-11	METAL CHIP	10K	5%	1/16W	R2664	1-218-957-11	METAL CHIP	2.2K	5%	1/16W
R2601	1-218-965-11	METAL CHIP	10K	5%	1/16W	R2665	1-218-957-11	METAL CHIP	2.2K	5%	1/16W
					(DH750)	R2666	1-216-833-11	METAL CHIP	10K	5%	1/10W
R2603	1-218-941-81	METAL CHIP	100	5%	1/16W	R2667	1-218-929-11	METAL CHIP	10	5%	1/16W
					(DH750)	R2668	1-218-965-11	METAL CHIP	10K	5%	1/16W
R2604	1-218-947-11	METAL CHIP	330	5%	1/16W	R2669	1-218-929-11	METAL CHIP	10	5%	1/16W
R2605	1-218-947-11	METAL CHIP	330	5%	1/16W	R2670	1-216-833-11	METAL CHIP	10K	5%	1/10W
R2606	1-218-941-81	METAL CHIP	100	5%	1/16W	R2671	1-218-965-11	METAL CHIP	10K	5%	1/16W
R2607	1-218-941-81	METAL CHIP	100	5%	1/16W	R2672	1-218-965-11	METAL CHIP	10K	5%	1/16W
R2609	1-218-933-11	METAL CHIP	22	5%	1/16W	R2673	1-216-833-11	METAL CHIP	10K	5%	1/10W
R2610	1-218-933-11	METAL CHIP	22	5%	1/16W	R2900	1-218-955-11	METAL CHIP	1.5K	5%	1/16W
R2611	1-218-941-81	METAL CHIP	100	5%	1/16W	R2901	1-218-989-11	METAL CHIP	1M	5%	1/16W
R2612	1-218-933-11	METAL CHIP	22	5%	1/16W	R2902	1-218-949-11	METAL CHIP	470	5%	1/16W
R2613	1-218-941-81	METAL CHIP	100	5%	1/16W	R2904	1-218-947-11	METAL CHIP	330	5%	1/16W
					(DH750)	R2906	1-218-947-11	METAL CHIP	330	5%	1/16W
R2614	1-218-941-81	METAL CHIP	100	5%	1/16W	R2907	1-218-873-11	METAL CHIP	12K	0.5%	1/10W
					(DH750)	R2908	1-218-941-81	METAL CHIP	100	5%	1/16W
R2615	1-218-941-81	METAL CHIP	100	5%	1/16W	R2910	1-218-965-11	METAL CHIP	10K	5%	1/16W
					(DH750)	R2911	1-218-965-11	METAL CHIP	10K	5%	1/16W

STR-DH550/DH750

MAIN **NFC ICON PC** **POWER KEY** **STANDBY DCDC**

Ref. No.	Part No.	Description	Remark
R2912	1-218-965-11	METAL CHIP 10K 5%	1/16W
R2913	1-218-965-11	METAL CHIP 10K 5%	1/16W
R2914	1-208-931-11	METAL CHIP 68K 0.5%	1/16W
R2915	1-208-699-11	METAL CHIP 4.7K 0.5%	1/16W
R2916	1-208-709-11	METAL CHIP 12K 0.5%	1/16W
R2918	1-216-833-11	METAL CHIP 10K 5%	1/10W
R2919	1-216-864-11	SHORT CHIP 0	
R2920	1-208-939-11	METAL CHIP 150K 0.5%	1/16W
R2921	1-218-977-11	METAL CHIP 100K 5%	1/16W
R2922	1-218-953-11	METAL CHIP 1K 5%	1/16W
R2923	1-208-953-11	METAL CHIP 560K 0.5%	1/16W
R2924	1-208-911-11	METAL CHIP 10K 0.5%	1/16W
R2925	1-208-911-11	METAL CHIP 10K 0.5%	1/16W
R2926	1-218-965-11	METAL CHIP 10K 5%	1/16W
R2927	1-218-965-11	METAL CHIP 10K 5%	1/16W (DH750)
R2929	1-218-941-81	METAL CHIP 100 5%	1/16W
R2931	1-218-959-11	METAL CHIP 3.3K 5%	1/16W
R2932	1-218-959-11	METAL CHIP 3.3K 5%	1/16W
R2933	1-216-833-11	METAL CHIP 10K 5%	1/10W
R2934	1-216-833-11	METAL CHIP 10K 5%	1/10W
< COMPOSITION CIRCUIT BLOCK >			
RB2000	1-234-375-21	RES, NETWORK 1K (1005X4)	
RB2001	1-234-372-11	RES, NETWORK 100 (1005X4)	
RB2002	1-234-372-11	RES, NETWORK 100 (1005X4)	
RB2003	1-234-372-11	RES, NETWORK 100 (1005X4)	
RB2005	1-234-372-11	RES, NETWORK 100 (1005X4)	
RB2006	1-234-372-11	RES, NETWORK 100 (1005X4)	
RB2007	1-234-372-11	RES, NETWORK 100 (1005X4)	
RB2008	1-234-372-11	RES, NETWORK 100 (1005X4)	
RB2009	1-234-376-11	RES, NETWORK 2.2K (1005X4)	
RB2010	1-234-372-11	RES, NETWORK 100 (1005X4)	
RB2011	1-234-372-11	RES, NETWORK 100 (1005X4)	
RB2012	1-234-372-11	RES, NETWORK 100 (1005X4)	
RB2013	1-234-372-11	RES, NETWORK 100 (1005X4)	
RB2014	1-234-372-11	RES, NETWORK 100 (1005X4)	
RB2015	1-234-372-11	RES, NETWORK 100 (1005X4)	
RB2800	1-234-372-11	RES, NETWORK 100 (1005X4)	
RB2802	1-234-372-11	RES, NETWORK 100 (1005X4)	
RB2803	1-234-372-11	RES, NETWORK 100 (1005X4)	
< RELAY >			
RY301	1-755-696-11	RELAY	
RY350	1-755-307-21	RELAY	
RY355	1-755-307-21	RELAY	
RY360	1-755-307-21	RELAY (DH750)	
RY365	1-755-307-21	RELAY	
RY380	1-755-307-21	RELAY	
RY920	1-755-593-11	RELAY	
< TERMINAL >			
TB501	1-854-007-11	TERMINAL BOARD, SPEAKER 6P (SPEAKERS IMPEDANCE USE 6-16Ω CENTER/ FRONT A L/R)	
TB502	1-854-006-11	TERMINAL BOARD, SPEAKER 4P (SPEAKERS IMPEDANCE USE 6-16Ω SURROUND L/R)	
TB503	1-854-006-11	TERMINAL BOARD, SPEAKER 4P (DH750) (SPEAKERS IMPEDANCE USE 6-16Ω SURROUND BACK/ BI-AMP/ FRONT HIGH/ FRONT B L/R)	

Ref. No.	Part No.	Description	Remark
< THERMISTOR >			
△ TH251	1-804-045-11	THERMISTOR	
△ TH252	1-804-045-11	THERMISTOR	
< VIBRATOR >			
X2001	1-781-646-21	VIBRATOR, CERAMIC (4MHz)	
X2200	1-814-350-11	QUARTZ CRYSTAL UNITS (24.576MHz)	
X2400	1-814-242-11	VIBRATOR, CRYSTAL (25MHz)	
X2600	1-781-646-21	VIBRATOR, CERAMIC (4MHz)	
X2900	1-814-482-11	QUARTZ CRYSTAL UNIT (16.9344MHz)	

NFC ICON PC BOARD (DH750)			

< CONNECTOR >			
CN2550	1-820-112-51	CONNECTOR, FFC/FPC 9P (DH750)	
CN2551	1-820-384-31	CONNECTOR, FFC/FPC (LIF) 8P (DH750)	

A-1989-183-A	POWER KEY BOARD, COMPLETE		

< DIODE >			
D110	8-719-057-29	DIODE SML78423C-TP15	
< TRANSISTOR >			
Q110	6-553-266-01	TR 2PD601ART	
Q111	6-553-266-01	TR 2PD601ART	
< RESISTOR >			
R173	1-250-640-11	METAL CHIP 10K 1%	1/10W
R174	1-250-624-11	METAL CHIP 2.2K 1%	1/10W
R175	1-250-592-11	METAL CHIP 100 1%	1/10W
R176	1-250-584-11	METAL CHIP 47 1%	1/10W
R178	1-250-664-11	METAL CHIP 100K 1%	1/10W
R179	1-250-664-11	METAL CHIP 100K 1%	1/10W
R180	1-250-640-11	METAL CHIP 10K 1%	1/10W
R181	1-250-624-11	METAL CHIP 2.2K 1%	1/10W
R182	1-250-632-11	METAL CHIP 4.7K 1%	1/10W
R183	1-250-648-11	METAL CHIP 22K 1%	1/10W
< SWITCH >			
S111	1-762-875-21	SWITCH, TACTILE (TUNING +)	
S112	1-762-875-21	SWITCH, TACTILE (TUNING -)	
S113	1-762-875-21	SWITCH, TACTILE (TUNING MODE)	
S114	1-762-875-21	SWITCH, TACTILE (SPEAKERS)	
S115	1-762-875-21	SWITCH, TACTILE (I/⊙)	

A-1988-684-A	STANDBY DCDC BOARD, COMPLETE (DH750: US, CND, MX, TW)		
A-1989-572-A	STANDBY DCDC BOARD, COMPLETE (DH750: AEP, UK, AUS)		
A-1989-616-A	STANDBY DCDC BOARD, COMPLETE (BR)		
A-1989-624-A	STANDBY DCDC BOARD, COMPLETE (DH550: US, CND)		
A-1989-634-A	STANDBY DCDC BOARD, COMPLETE (DH550: AEP, UK, AUS)		
< CAPACITOR >			
C902	1-118-361-11	CERAMIC CHIP 0.1uF 10%	50V
C907	1-100-756-91	CERAMIC CHIP 0.047uF 10%	50V

Ref. No.	Part No.	Description	Remark	Ref. No.	Part No.	Description	Remark
C908	1-100-756-91	CERAMIC CHIP	0.047uF 10% 50V			< DIODE >	
C960	1-118-361-11	CERAMIC CHIP	0.1uF 10% 50V				
C961	1-118-361-11	CERAMIC CHIP	0.1uF 10% 50V				
C962	1-118-361-11	CERAMIC CHIP	0.1uF 10% 50V				
C963	1-126-936-11	ELECT	3300uF 20% 16V				
C969	1-126-960-11	ELECT	1uF 20% 50V				
C970	1-118-386-11	CERAMIC CHIP	0.1uF 10% 16V				
C971	1-118-386-11	CERAMIC CHIP	0.1uF 10% 16V (DH550)				
C975	1-116-716-11	CERAMIC CHIP	10uF 10% 16V (DH750)				
C976	1-116-716-11	CERAMIC CHIP	10uF 10% 16V (DH750)				
C977	1-118-386-11	CERAMIC CHIP	0.1uF 10% 16V (DH750)				
C978	1-114-802-11	CERAMIC CHIP	0.0033uF 10% 50V (DH750)				
C979	1-118-386-11	CERAMIC CHIP	0.1uF 10% 16V (DH750)				
C980	1-114-802-11	CERAMIC CHIP	0.0033uF 10% 50V (DH750)				
C981	1-116-713-11	CERAMIC CHIP	22uF 20% 10V				
C982	1-116-713-11	CERAMIC CHIP	22uF 20% 10V				
C1902	1-116-865-11	CERAMIC CHIP	10uF 10% 25V				
C1903	1-116-865-11	CERAMIC CHIP	10uF 10% 25V				
C1904	1-118-361-11	CERAMIC CHIP	0.1uF 10% 50V				
C1905	1-118-361-11	CERAMIC CHIP	0.1uF 10% 50V				
C1907	1-118-399-11	CERAMIC CHIP	0.0022uF 10% 50V				
C1909	1-118-386-11	CERAMIC CHIP	0.1uF 10% 16V				
C1910	1-116-151-11	CERAMIC CHIP	0.001uF 2% 50V				
C1912	1-116-713-11	CERAMIC CHIP	22uF 20% 10V				
C1913	1-116-713-11	CERAMIC CHIP	22uF 20% 10V				
C1914	1-118-361-11	CERAMIC CHIP	0.1uF 10% 50V				
C1922	1-116-865-11	CERAMIC CHIP	10uF 10% 25V				
C1923	1-116-865-11	CERAMIC CHIP	10uF 10% 25V				
C1924	1-118-361-11	CERAMIC CHIP	0.1uF 10% 50V				
C1925	1-118-361-11	CERAMIC CHIP	0.1uF 10% 50V				
C1927	1-118-399-11	CERAMIC CHIP	0.0022uF 10% 50V				
C1929	1-118-386-11	CERAMIC CHIP	0.1uF 10% 16V				
C1930	1-116-151-11	CERAMIC CHIP	0.001uF 2% 50V				
C1932	1-116-713-11	CERAMIC CHIP	22uF 20% 10V				
C1933	1-116-713-11	CERAMIC CHIP	22uF 20% 10V				
C1934	1-118-361-11	CERAMIC CHIP	0.1uF 10% 50V				
C1942	1-116-865-11	CERAMIC CHIP	10uF 10% 25V				
C1943	1-116-865-11	CERAMIC CHIP	10uF 10% 25V				
C1944	1-118-361-11	CERAMIC CHIP	0.1uF 10% 50V				
C1945	1-118-361-11	CERAMIC CHIP	0.1uF 10% 50V				
C1947	1-118-459-11	CERAMIC CHIP	0.01uF 10% 25V				
C1949	1-118-386-11	CERAMIC CHIP	0.1uF 10% 16V				
C1950	1-116-151-11	CERAMIC CHIP	0.001uF 2% 50V				
C1952	1-116-713-11	CERAMIC CHIP	22uF 20% 10V				
C1953	1-116-713-11	CERAMIC CHIP	22uF 20% 10V				
C1954	1-118-361-11	CERAMIC CHIP	0.1uF 10% 50V				
C1976	1-126-944-11	ELECT	3300uF 20% 25V				
		< CONNECTOR >					
* CN941	1-564-507-11	PLUG, CONNECTOR 4P					
CN1901	1-815-875-21	PIN, CONNECTOR (PC BOARD) (12P)					
* CNP901	1-793-660-11	PIN, CONNECTOR (PC BOARD) 3P					
* CNP902	1-580-689-11	PIN, CONNECTOR (PC BOARD) 4P					
* CNP903	1-564-687-11	PIN, CONNECTOR (3.96mm PITCH) 3P (BR)					
D901	8-719-053-18	DIODE 1SR154-400TE-25					
D902	8-719-053-18	DIODE 1SR154-400TE-25					
D903	8-719-053-18	DIODE 1SR154-400TE-25					
D904	8-719-053-18	DIODE 1SR154-400TE-25					
D905	6-500-514-01	DIODE BAV70					
D906	6-502-961-01	DI DA2J10100L					
D923	6-503-401-01	DI D3SBA60-7101					
		< EARTH TERMINAL >					
* ET1900	1-780-408-11	TERMINAL, LUG					
		< FUSE >					
△ F940	1-523-086-11	FUSE (3.15A/250V)					
△ F941	1-523-086-11	FUSE (3.15A/250V)					
		< FUSE HOLDER >					
FH901	1-533-217-41	HOLDER, FUSE					
FH902	1-533-217-41	HOLDER, FUSE					
FH903	1-533-217-41	HOLDER, FUSE (BR)					
FH904	1-533-217-41	HOLDER, FUSE (BR)					
		< IC >					
IC901	6-716-739-01	IC BD00GC0WEFJ-SE2 (DH550)					
IC902	(Not supplied)	IC RT7237ALGSP (DH750)					
IC1905	6-717-879-01	IC RT8293ALZSP					
IC1906	6-717-879-01	IC RT8293ALZSP					
IC1907	6-717-879-01	IC RT8293ALZSP					
		< JUMPER >					
JS901	1-211-950-11	SHORT CHIP 0 (EXCEPT BR)					
JS904	1-211-950-11	SHORT CHIP 0 (BR)					
JS906	1-211-950-11	SHORT CHIP 0 (BR)					
		< COIL >					
L910	1-457-995-11	INDUCTOR 10uH (DH750)					
L1901	1-457-995-11	INDUCTOR 10uH					
L1902	1-457-995-11	INDUCTOR 10uH					
L1903	1-457-995-11	INDUCTOR 10uH					
L1904	1-457-995-11	INDUCTOR 10uH					
L1905	1-457-995-11	INDUCTOR 10uH					
L1906	1-457-995-11	INDUCTOR 10uH					
		< TRANSISTOR >					
Q951	6-553-266-01	TR 2PD601ART					
Q952	6-553-266-01	TR 2PD601ART					
		< RESISTOR >					
R960	1-216-829-11	METAL CHIP 4.7K 5% 1/10W					
R961	1-216-833-11	METAL CHIP 10K 5% 1/10W					
R963	1-216-833-11	METAL CHIP 10K 5% 1/10W					
R971	1-249-395-11	CARBON 15 5% 1/4W					
R972	1-249-394-11	CARBON 12 5% 1/4W					
R973	1-216-841-11	METAL CHIP 47K 5% 1/10W					
R974	1-216-825-11	METAL CHIP 2.2K 5% 1/10W					
R978	1-208-711-11	METAL CHIP 15K 0.5% 1/16W (DH750)					
R979	1-218-892-11	METAL CHIP 75K 0.5% 1/10W					
R981	1-208-920-81	METAL CHIP 24K 0.5% 1/16W					

Note: IC902 (DH750) on the STANDBY DCDC board cannot exchange with single. When this part on the STANDBY DCDC board is damaged, exchange the entire mounted board.

STR-DH550/DH750

STANDBY DCDC

TUNER1

Ref. No.	Part No.	Description	Remark
R1901	1-218-933-11	METAL CHIP 22 5%	1/16W
R1903	1-218-965-11	METAL CHIP 10K 5%	1/16W
R1905	1-216-793-11	METAL CHIP 4.7 5%	1/10W
R1906	1-208-911-11	METAL CHIP 10K 0.5%	1/16W
R1907	1-208-923-11	METAL CHIP 33K 0.5%	1/16W
R1908	1-208-923-11	METAL CHIP 33K 0.5%	1/16W
R1909	1-218-977-11	METAL CHIP 100K 5%	1/16W
R1911	1-218-933-11	METAL CHIP 22 5%	1/16W
R1913	1-218-961-11	METAL CHIP 4.7K 5%	1/16W
R1915	1-216-793-11	METAL CHIP 4.7 5%	1/10W
R1916	1-208-911-11	METAL CHIP 10K 0.5%	1/16W
R1917	1-208-715-11	METAL CHIP 22K 0.5%	1/16W
R1918	1-208-911-11	METAL CHIP 10K 0.5%	1/16W
R1919	1-218-977-11	METAL CHIP 100K 5%	1/16W
R1921	1-218-933-11	METAL CHIP 22 5%	1/16W
R1923	1-218-961-11	METAL CHIP 4.7K 5%	1/16W
R1925	1-216-793-11	METAL CHIP 4.7 5%	1/10W
R1926	1-208-709-11	METAL CHIP 12K 0.5%	1/16W
R1927	1-218-990-81	SHORT CHIP 0	
R1928	1-208-713-11	METAL CHIP 18K 0.5%	1/16W
R1929	1-218-977-11	METAL CHIP 100K 5%	1/16W
R1930	1-218-974-11	METAL CHIP 56K 5%	1/16W
R1931	1-218-974-11	METAL CHIP 56K 5%	1/16W
R1932	1-218-974-11	METAL CHIP 56K 5%	1/16W
< RELAY >			
△ RY951	1-755-697-11	RELAY	
< SWITCH >			
S901	1-571-437-21	SWITCH, POWER VOLTAGE CHANGE (BR)	
< TRANSFORMER >			
△ T902	1-697-151-11	POWER TRANSFORMER (SUB) (DH550: US, CND)	
△ T902	1-697-152-11	POWER TRANSFORMER (SUB) (DH550: AEP, UK, AUS)	
△ T902	1-697-234-21	POWER TRANSFORMER (SUB) (DH750: AEP, UK, AUS)	
△ T902	1-697-267-21	POWER TRANSFORMER (SUB) (DH750: US, CND, MX, TW)	
△ T902	1-697-273-21	POWER TRANSFORMER (SUB) (BR)	

TUNER1AMF BOARD (US, CND, MX, BR) TUNER1AMPR BOARD (AEP, UK, AUS, TW) *****			
< CAPACITOR >			
C101	1-100-155-91	CERAMIC CHIP 470PF 5%	100V
C102	1-116-734-11	CERAMIC CHIP 1uF 20%	16V
C103	1-116-734-11	CERAMIC CHIP 1uF 20%	16V
C105	1-116-734-11	CERAMIC CHIP 1uF 20%	16V
C106	1-165-176-11	CERAMIC CHIP 0.047uF 10%	16V
C107	1-165-176-11	CERAMIC CHIP 0.047uF 10%	16V
C108	1-116-729-11	CERAMIC CHIP 2.2uF 20%	10V
C109	1-118-289-11	CERAMIC CHIP 0.1uF 10%	16V
C110	1-116-717-11	CERAMIC CHIP 10uF 20%	10V
C111	1-116-734-11	CERAMIC CHIP 1uF 20%	16V
C112	1-116-734-11	CERAMIC CHIP 1uF 20%	16V

Ref. No.	Part No.	Description	Remark
< CONNECTOR >			
CN101	1-779-277-11	CONNECTOR, FFC (LIF (NON-ZIF)) 9P	
* CN103	1-506-680-11	PLUG, CONNECTOR (2.5MM) 3P (ANTENNA AM)	
CN104	1-780-920-11	TERMINAL (FMAMF) (US, CND, MX, BR) (ANTENNA FM 75Ω COAXIAL)	
< DIODE >			
D101	6-501-579-01	DIODE MC2837	
D102	6-501-579-01	DIODE MC2837	
D103	6-501-579-01	DIODE MC2837	
< FILTER >			
FL101	1-236-711-21	FILTER, BAND PASS	
< IC >			
IC101	6-717-980-01	IC RZ5B801-0001E2 (US, CND, MX, BR)	
IC101	6-717-981-01	IC RZ5B801-0002E2 (AEP, UK, AUS, TW)	
IC102	6-715-134-01	IC MM3404A33URE	
< JUMPER RESISTOR >			
JR101	1-216-864-11	SHORT CHIP 0	
JR102	1-216-296-11	SHORT CHIP 0	
JR105	1-216-296-11	SHORT CHIP 0	
JR106	1-216-864-11	SHORT CHIP 0	
JR109	1-216-296-11	SHORT CHIP 0	
JR112	1-216-296-11	SHORT CHIP 0	
< COIL >			
L101	1-457-998-11	COIL, AM ANTENNA	
L103	1-414-576-41	INDUCTOR 47nH	
L104	1-481-330-21	INDUCTOR 220nH	
L105	1-481-523-11	INDUCTOR 4.7uH	
< RESISTOR >			
R101	1-216-809-11	METAL CHIP 100 5%	1/10W
R103	1-216-801-11	METAL CHIP 22 5%	1/10W
R104	1-216-864-11	SHORT CHIP 0	
R105	1-216-801-11	METAL CHIP 22 5%	1/10W
R106	1-216-809-11	METAL CHIP 100 5%	1/10W
R107	1-216-809-11	METAL CHIP 100 5%	1/10W
R108	1-216-296-11	SHORT CHIP 0	
R109	1-216-864-11	SHORT CHIP 0	
R110	1-216-833-11	METAL CHIP 10K 5%	1/10W
R113	1-216-833-11	METAL CHIP 10K 5%	1/10W
< VIBRATOR >			
X101	1-767-317-11	VIBRATOR, CRYSTAL (32.768kHz)	

MISCELLANEOUS *****			
57	1-828-412-61	WIRE (FLAT TYPE) (29 CORE)	
59	1-828-167-61	WIRE (FLAT TYPE) (8 CORE) (DH750)	
60	1-828-308-61	WIRE (FLAT TYPE) (9 CORE) (DH750)	
61	8-989-470-05	RC-S801/A5 (WWW) (DH750)	
62	1-490-558-71	BLUETOOTH MODULE (DH750)	
63	1-828-202-61	WIRE (FLAT TYPE) (14 CORE) (DH750)	
△ 102	1-777-071-83	CORD, POWER (AEP)	
△ 102	1-833-566-21	POWER-SUPPLY CORD (AUS)	
△ 102	1-835-706-22	CORD, POWER-SUPPLY (BR)	

Note: If wire (flat type) is replaced, install it after bending it in the same form as that before replacement.

Ref. No.	Part No.	Description	Remark
△ 102	1-837-308-11	CORD, POWER-SUPPLY (US, CND)	
△ 102	1-837-344-11	CORD, POWER-SUPPLY (MX)	
△ 102	1-837-345-11	CORD, POWER-SUPPLY (TW)	
△ 102	1-839-999-21	POWER-SUPPLY CORD (UK)	
104	A-1846-561-A	TUNER1AMPR ASSY (AEP, UK, AUS, TW)	
104	A-1846-564-A	TUNER1AMF ASSY (US, CND, MX, BR)	
105	1-828-308-61	WIRE (FLAT TYPE) (9 CORE)	
153	1-828-379-61	WIRE (FLAT TYPE) (23 CORE)	
△ F901	1-532-465-33	FUSE (T3.15AL/250V) (AEP, AUS, UK)	
△ F901	1-532-504-33	FUSE, (T4AL/250V) (BR)	
△ F901	1-532-506-33	FUSE, (T6.3AL/250V) (MX, TW)	
△ F901	1-533-311-12	FUSE, GLASS (DIA.5) (8A/125V) (US, CND)	
△ F902	1-532-506-33	FUSE, (T6.3AL/250V) (BR)	
Q550	6-702-390-01	TRANSISTOR MN2488-OPY-MK	
Q551	6-702-391-01	TRANSISTOR MP1620-OPY-MK	
Q600	6-702-390-01	TRANSISTOR MN2488-OPY-MK	
Q601	6-702-391-01	TRANSISTOR MP1620-OPY-MK	
Q650	6-702-390-01	TRANSISTOR MN2488-OPY-MK	
Q651	6-702-391-01	TRANSISTOR MP1620-OPY-MK	
Q700	6-702-390-01	TRANSISTOR MN2488-OPY-MK	
Q701	6-702-391-01	TRANSISTOR MP1620-OPY-MK	
Q750	6-702-390-01	TRANSISTOR MN2488-OPY-MK	
Q751	6-702-391-01	TRANSISTOR MP1620-OPY-MK	
Q800	6-702-390-01	TRANSISTOR MN2488-OPY-MK (DH750)	
Q801	6-702-391-01	TRANSISTOR MP1620-OPY-MK (DH750)	
Q850	6-702-390-01	TRANSISTOR MN2488-OPY-MK (DH750)	
Q851	6-702-391-01	TRANSISTOR MP1620-OPY-MK (DH750)	
△ T901	1-697-237-21	POWER TRANSFORMER (MAIN) (MX)	
△ T901	1-697-238-21	POWER TRANSFORMER (MAIN) (BR)	
△ T901	1-697-367-11	POWER TRANSFORMER (MAIN) (AEP, UK, AUS)	
△ T901	1-697-368-11	POWER TRANSFORMER (MAIN) (US, CND, TW)	

ACCESSORIES

1-492-705-11	REMOTE COMMANDER (RM-AAU190) (including BATTERY LID)
1-542-830-11	MEASUREMENT MIC (MONO) (Optimizer microphone (ECM-AC2)) (DH550: AEP, AUS, US, CND/DH750)
1-754-741-21	LOOP ANTENNA (AM loop antenna (aerial))
1-793-184-41	CONNECTOR (F TYPE ADAPTOR) (FM wire antenna (aerial)) (DH550: AEP, AUS, US, CND/DH750)

Note: If wire (flat type) is replaced, install it after bending it in the same form as that before replacement.

