

Gas-Fired Wood-Burning Rotisserie BBQ Smoker

OWNER'S MANUAL



MLR-150 SPX-300 SPK-500 SP-700 MLR-850
(Additional models supported by this manual not pictured: SPK-1000 and SPK-1400)

* Smokers shown on Southern Pride delivery casters



Southern Pride smokers have been tested and approved by Intertek Testing Services,
and are ETL listed to ANSI Z83.11b - 2009, CSA 1.8b - 2009,
and to NSF/ANSI Standard 4.
ETL File Number 4007026



Southern Pride smokers are gas-fired, wood-burning, ETL listed, commercial cooking appliances whose installation, operation, and maintenance should comply with the instructions in this manual, NFPA® 96 and other codes and standards as called out in this manual.

For a list of ETL approved smokers go to www.intertek.com/directories, click on ETL Listed Mark Directory and search “Southern Pride.”

For more information on NFPA® 96, or to obtain a copy of the latest publication, please contact:

**NFPA®
1 Batterymarch Park
PO Box 9101
Quincy, MA 02169-7471
www.nfpa.org**

CONGRATULATIONS!

In selecting Southern Pride, you have chosen the finest, most advanced and most fully automatic wood burning barbecue smoker available. With us, “ It’s Simply, a Matter of Pride”.

Please read this Manual carefully prior to installation, operation and maintenance of your Southern Pride smoker. Proper installation, operation, and maintenance are essential for your satisfaction and safe operation.

KEEP THIS MANUAL FOR REFERENCE

NOTE: An Electrical Diagram for this appliance can be found on the inside of the service access panel. This smoker may be operated outdoors.

TABLE OF CONTENTS

Safety Information and Precautions.....	5
Diagram of Controls & Components.....	6-7
INSTALLATION	
Receiving the Smoker.....	8
Delivery Location.....	8
Unloading the Smoker.....	9
Unpacking the Smoker.....	9
Site Instructions	10-11
Electrical Instructions.....	12
Gas Piping Instructions.....	13-15
Gas Connection Instructions	16
Burner Specification.....	17
Venting Instructions.....	18-19
OPERATION	
Product Loading Instructions	20
Firebox Loading Instructions.....	21
Control Operating Instructions.....	21-22
Product Unloading Instructions.....	23
Ash Removal Instructions.....	23
Grease Removal Instructions	24
Wood Storage Instructions	24
Mobile Smoker Operations.....	25
Mobile Smoker Electrical Information	25
Mobile Smoker Warnings.....	25-27
Propane Tank Operations	28-30
MAINTENANCE	
Daily	31
Weekly	31-32
Monthly	33-34
Annually/Semi-Annually.....	35
As Needed	36-37
Wiring Diagrams	38-41
Replacement Parts List	42-43
Before You Call For Service.....	44
Troubleshooting the Gas Burner	45
Limited Warranty	46

SAFETY INFORMATION AND PRECAUTIONS

This Manual should be considered a permanent part of this smoker. **THE SMOKER MUST BE INSTALLED BY A QUALIFIED SERVICE TECHNICIAN.** All troubleshooting guides, component views and parts lists included in this manual are for general reference only and are intended for use by qualified technical personnel.



DANGER:

Improper installation, alteration, adjustment, service, or maintenance could result in severe injury, death, or cause property damage. Read the installation, operating, and maintenance instructions thoroughly before installing or servicing this equipment.



DANGER:

Do not store or use gasoline or other flammable vapors or liquids in the vicinity of this or any other appliances.



CAUTION:

Metal parts and surfaces of this smoker become extremely hot when in operation. To avoid burns, always use hand protection when operating the smoker.



WARNING:

**FOR YOUR SAFETY
IF YOU SMELL GAS.....**

1. Open windows
2. Do not touch electrical switches
3. Extinguish any open flames
4. Immediately call your gas supplier



WARNING:

**CARBON MONOXIDE
POISONING HAZARD**

Carbon monoxide is a colorless, odorless gas that can kill. Follow these rules to control carbon monoxide.

- Do not use the smoker if in an unvented, enclosed area. Carbon monoxide may accumulate.
- Allow only qualified burner service persons to adjust the burner. Special instruments and training are required.
- Read the owner's manual before using.



WARNING:

ELECTRIC SHOCK HAZARD

Follow these rules to avoid electric shock.

- Use only a properly grounded circuit.
- Do not spray water directly on electrical components.
- Turn off power before servicing.

1. **IT IS EXTREMELY IMPORTANT TO FOLLOW THE PRESCRIBED CLEANING INSTRUCTIONS. GREASE OR SOLIDS BUILDUP INSIDE THE SMOKER COULD RESULT IN A FIRE HAZARD.**
2. This smoker is intended for use in commercial facilities where all operators are familiar with the purpose, limitations, and associated hazards of this equipment. The operating instructions and warnings must be read and understood by all operators and users.
3. This manual and all supplied instructions, diagrams, schematics, parts lists, notices and labels must remain with the smoker even if the smoker is sold or moved to another location.
4. The area around the smoker **MUST** be kept clear and free of combustible materials, gasoline and other flammable vapors and liquids.
5. The flow of combustion and ventilating air **MUST NOT** be obstructed from reaching the smoker.
6. The frame of the smoker **MUST** be electrically grounded at all times. See "Electrical instructions".
7. Caution should be used when opening and closing the firebox door. The door is **HOT** during operation.
8. **DO NOT** remove service compartment access panels when smoker is in operation or leave off during operation.
9. Gas burners require the services of a qualified service technician for proper setting and adjustment. If the burner does not appear to be operating properly, **DO NOT ATTEMPT TO ADJUST THE BURNER YOURSELF.**
10. **DO NOT** allow unqualified personnel to perform service work or adjustments on this smoker. Doing so, will **VOID WARRANTY** and could result in a hazardous condition.
11. Ensure new employees, who might operate the smoker, are properly instructed and supervised on the operation and safety information prior to operating the smoker.
12. Ashes removed from the firebox should be stored in a non-combustible container with a sealed lid only. Store ashes in a well ventilated area. **FUMES COULD BE HAZARDOUS.**

DIAGRAM OF CONTROLS AND COMPONENTS

(Model SPX-300 Shown)

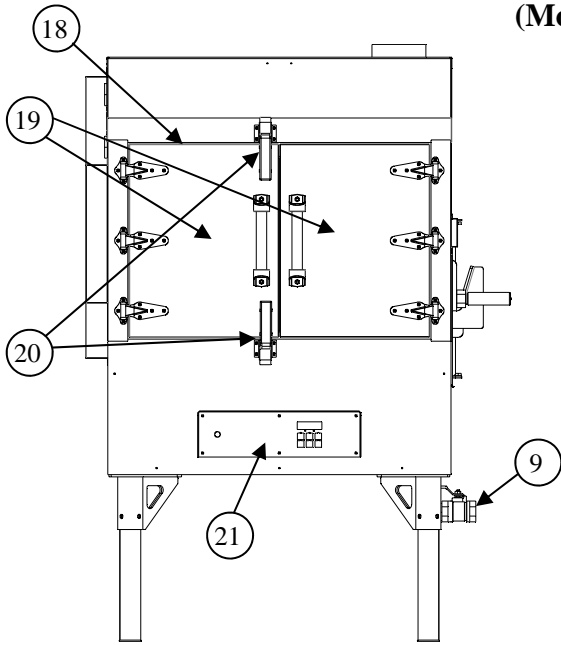

Front View

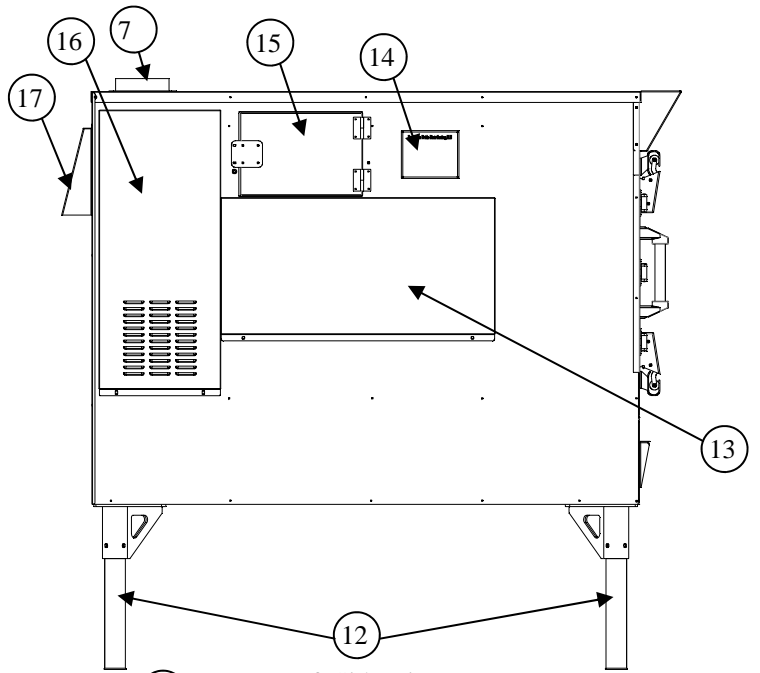

Left Side View

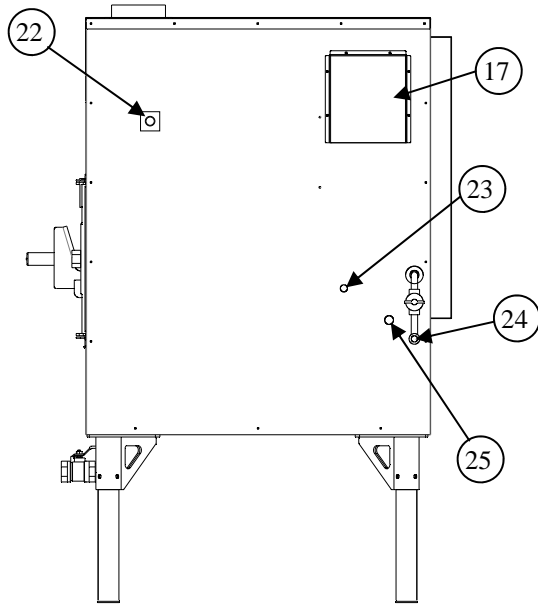

Rear View

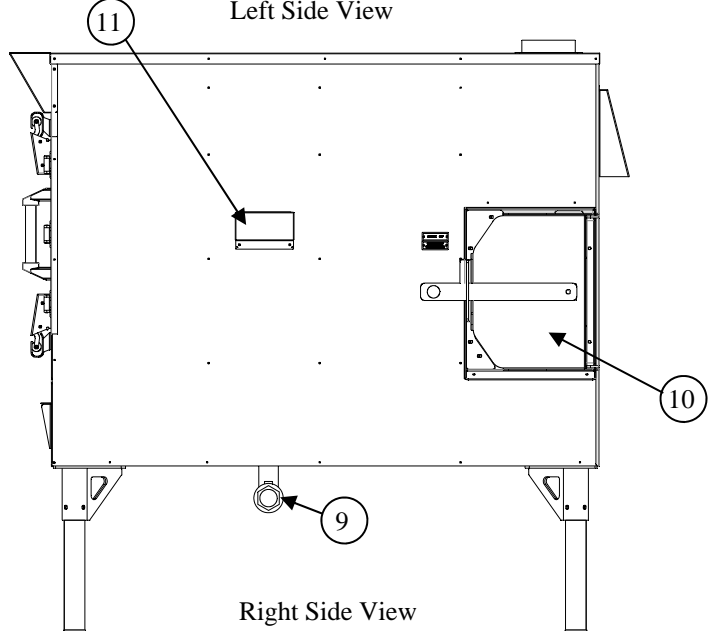

Right Side View

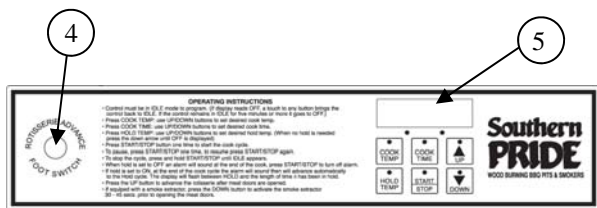

Optional Digital Cook & Hold Control

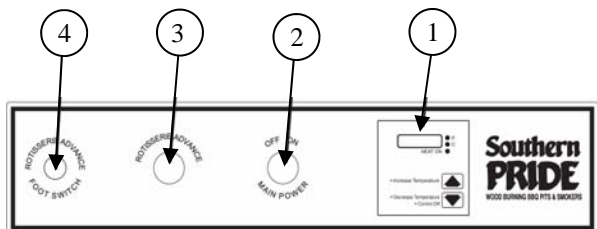

Standard Digital Control

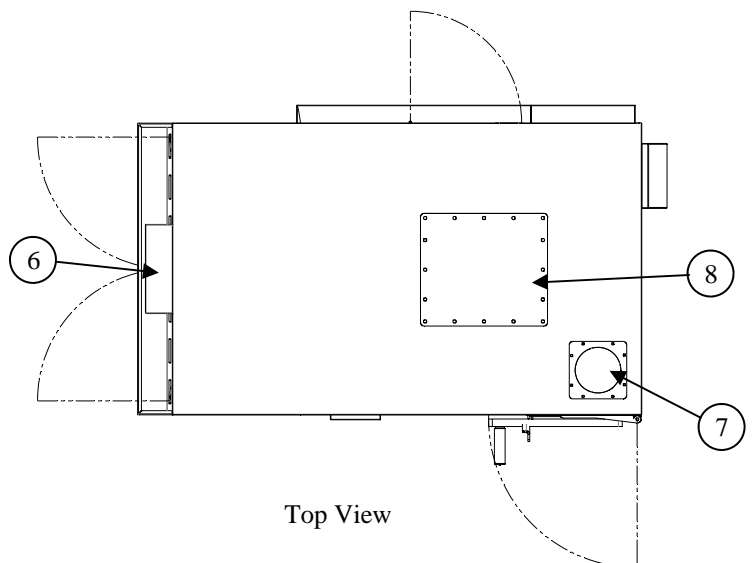

Top View

DIAGRAM OF CONTROL AND COMPONENTS

1. **DIGITAL THERMOSTAT CONTROL** - Digital thermostat control allows for cook temperature selection range between 140°F to 325°F, with OFF position. Maintains desired smoker temperature by controlling the gas burner. It also displays the actual temperature inside the smoker during the cook cycle.
2. **MAIN POWER SWITCH** - Activates the rotisserie, convection fan, thermostat, and red indicator lamp. (The red indicator lamp on the main power switch indicates when the switch is ON).
3. **ROTISSERIE ADVANCE SWITCH** - Momentarily activates rotisserie to advance the product racks for loading and unloading when the smoker door is open, or the main power switch is OFF.
4. **ROTISSERIE ADVANCE FOOT SWITCH** – Provides hands free operation to advance the rotisserie while loading or unloading product.
5. **DIGITAL COOK & HOLD CONTROL (Optional)** - Provides precise temperature control of the smoker along with control of the other functions of the smoker.
6. **FRONT FLUE (Optional)** - Designed for use with VSP Hood System or Type-1 Canopy hood.
7. **REAR FLUE COLLAR (Optional)** - For connection of 6” chimney pipe. Typically used for direct vent & mobile applications.
8. **SMOKE EXTRACTOR DAMPER (Optional)** - The smoke extractor damper enables the operator, **through the use of a customer supplied exhaust fan**, to evacuate the smoke from the smoker prior to fully opening the product loading door(s).
9. **GREASE DRAIN VALVE** – Open valve to drain grease from smoker after each cook. **DO NOT connect the grease drain to the building drain system or any other drain connection.**
10. **FIREBOX DOOR** - Provides access to the firebox chamber for loading wood and ash removal. **Keep closed while cooking.**
11. **BEARING COVER** - Provides access to rotisserie axle bearing.
12. **CABINET LEGS** - Provides adjustment for leveling of the smoker.
13. **DRIVE SYSTEM COVER** - Access to chain and driven sprocket on rotisserie axle.
14. **DATA PLATE** - Label containing smoker’s serial number, model number, manufactured date, etc.
15. **CONVECTION FAN ACCESS DOOR**– **All models except the SP-700 and SPK-1400 where the fan access is on the rear of the smoker.** Provides access to the fan blade for cleaning. **Maintaining a CLEAN fan blade is critical to the overall performance of the smoker.**
16. **SERVICE COMPARTMENT COVER** - Access to service bay where burner, convection fan motor, drive motor, and shock relay are located.
17. **SERVICE COMPARTMENT VENT** - Air vent to cool electrical components in service bay.
18. **DOOR INTERLOCK SWITCH** - When product loading door(s) are opened, the door interlock switch automatically turns OFF the rotisserie, convection fan and gas burner. On smokers with an optional smoke extractor the smoke extractor is automatically activated. On smokers with optional VSP vent hood systems the exhaust fan is automatically switched to high speed.
19. **PRODUCT LOADING DOOR(S)** – Provides access to load/unload product and for cleaning the interior of the smoker.
20. **PRODUCT LOADING DOOR LATCHES** - Latches apply positive pressure and seals doors.
21. **CONTROL PANEL INTERFACE** - Location of smoker control panel, where cooking parameters are set and monitored.
22. **MOISTURE INFUSION SYSTEM PORT** - Optional moisture system produces steam in the cooking chamber, primarily used with competition cooking (solid fuel cooking).
23. **AUXILIARY POWER CONNECTION** - Power supply access point used to power the smoke extractor exhaust fan or VSP eyebrow hood system.
24. **GAS SUPPLY CONNECTION** - Drip leg connection point for incoming gas supply to smoker.
25. **POWER CORD CONNECTION** - Access point for supply power cord to smoker.

INSTALLATION

RECEIVING THE SMOKER

Your smoker can be shipped via a contract hauler on a flatbed trailer (all models), or Common Carrier (all models except SPK-1400 and trailered smokers). Once the smoker arrives you will need a forklift to remove the crated smoker from the truck (Common Carrier deliveries) and install the permanent legs on the smoker (all deliveries).

Model	Approx. Wt. Uncrated	Approx. Wt. Crated
MLR-150	656 lb.	875 lb.
SPX-300	910 lb.	1150 lb.
SPK-500	1204 lb.	1480 lb.
SP-700	1512 lb.	2000 lb.
MLR-850	1576 lb.	1875 lb.
SPK-1000	2164 lb.	2530 lb.
SPK-1400	2400 lb.	NA

NOTE: The above weights are for the base model only.



WARNING:

If the forklift forks are not long enough to support the entire smoker/crate do not attempt to move the smoker; obtain another forklift or use fork extensions.

DELIVERY LOCATION

Commercial smokers are large and heavy. Before scheduling the delivery of your smoker have a plan and location in place to accept the delivery of the smoker and maneuver the smoker into the desired installation location. The trucker will require a flat, level surface that is safe from traffic to unload the smoker. A forklift will be required to unload the smoker and install the permanent legs on the smoker. The trucker is only responsible for delivery of the smoker. It is your responsibility to unpack the smoker, move it to its installation location, and install the smoker.



WARNING:

Only proper heavy lifting machinery and heavy lifting equipment should be used for unloading, moving and installing the smoker. This duty should only be performed by professionals trained in this kind of work. Improper handling of the equipment could result in damaging the smoker or personal injury and even death.

UNLOADING THE SMOKER

Smokers Shipped via Common Carrier

Remove the crated smoker from the truck using the appropriate forklift. Note any damage to the crate, smoker or accessories. **Do not sign the delivery bill until the smoker has been inspected and any damage noted on the delivery bill.**

The smoker is shipped bolted to a wooden pallet with an industrial cardboard carton. Once the smoker is in a level and safe place remove the cardboard carton and open the product loading doors. Plastic zip ties secure a cardboard box and permanent legs to one of the product racks of the smoker. Remove the cardboard box and permanent legs from the product rack. The smoker is secured to the wooden pallet with a bolt on each leg. After removing the 4 bolts securing the smoker to the wooden pallet use the appropriate forklift to lift the smoker off of the wooden pallet. With the wooden pallet removed from under the smoker, and the smoker still lifted by the forklift, install the permanent legs on the smoker. The permanent legs slide into the leg receivers on the bottom of the smoker and should be secured tightly using the provided set screws. After securing the permanent legs, slowly lower the smoker to the ground.

Smokers Shipped via Contract Hauler

The driver will unload the smoker from the trailer. Once the smoker is in a level and safe place remove the white protective wrap from the outside of the smoker and open the product loading doors. Plastic zip ties secure a cardboard box and permanent legs to one of the product racks of the smoker. Remove the cardboard box and permanent legs from the product rack. Using the appropriate forklift, lift the smoker and remove the delivery casters from the smoker and install the permanent legs. The permanent legs slide into the leg receivers on the bottom of the smoker and should be secured tightly using the provided set screws. After securing the permanent legs, slowly lower the smoker to the ground.

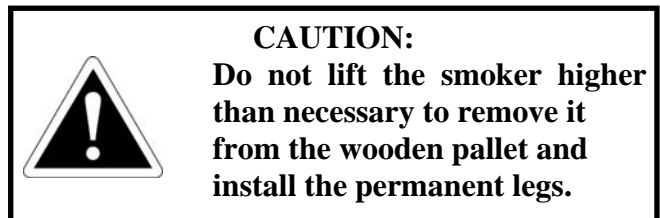
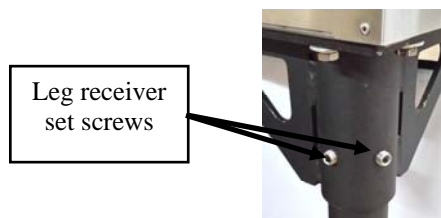

UNPACKING THE SMOKER

The cardboard box inside the smoker contains the following items:

- Sample seasoning and sauces. Bulk sizes are available. Please contact your authorized Southern Pride distributor for additional information.
- Pneumatic foot pedal. Connect to the control panel for hands-free operation of rotisserie. See pages 6 and 7 for connection location.
- 90 degree drain elbow. Connect to the grease drain ball valve to direct the draining grease towards the ground. See pages 6 and 7 for connection location.

The smoker is shipped with plastic zip ties holding the hanger racks to the rotisserie wheels. These zip ties should be removed prior to initial operation.

SITE INSTRUCTIONS

The Southern Pride smoker must be installed in a location that will permit the smoker to function for its intended purpose and to allow adequate clearance for ventilation, proper cleaning, and maintenance access.

Minimum Clearance Requirement from Combustible Material

Back.....18” (457mm)	Firebox Door Side.....24” (610mm)
Top.....18” (457mm)	Service Bay Side.....18” (457mm)
Front.....48” (1219mm)	

NOTE: If provision is made for service access, service bay side & back clearance can be reduced to 2” (51mm).



WARNING: Failure to maintain proper safety, storage, handling, and ash removal for solid fuel appliances on or around combustible materials may result in fire, property damage and/or death. Our product listing allows for the smoker to be installed on a combustible surface however, Southern Pride recommends the use of a noncombustible material for the floor surface area under the fire box, which should extend at least 6” beyond each side of the fire box, and outward from the smoker beyond the area needed for placement of the ash container.

During operation the smoker must be level to allow for smooth movement of the rotisserie wheels and drive system, to limit the movement of product on the product racks and to allow for proper grease drainage. If adjustment is necessary to level the smoker each of the legs can be adjusted up or down by loosening the 2 set screws on each leg and adjusting the legs.



CAUTION:

The appropriate sized forklift should be used to lift the smoker to adjust the leg height and the smoker should not be lifted any higher than necessary to perform the adjustment.

THROUGH THE WALL INSTALLATIONS

When installing a smoker through a wall made of combustible material an insulation kit must be used. The insulation board must be installed between the smoker and the combustible material. The following insulation kits consist of 1 inch thick, 8 inches wide insulation board that is installed on the top and each side of the smoker.

Through the Wall Insulation Kits			
Model	Kit Number	Model	Kit Number
MLR-150	087002	MLR-850	087003
SPX-300	087003	SPK-1000	087004
SPK-500	087005	SPK-1400	087006
SP-700	087004		

The wall cutout should be 2.5 inches wider than the smoker width and 1.25 inches taller than the smoker height to allow space for the insulation board between the wall and the smoker.

Also available is a stainless steel trim kit that will cover the gap between the smoker and the wall on all four sides of the smoker. The trim kit is only for one side of the building; two can be used for the interior and exterior of the building.

NOTE: When using a VSP hood system in a through the wall installation, a special insulation and stainless steel trim kit must be ordered. The special kits are designed with taller side pieces to extend beyond the height of the smoker to also account for the height of the VSP hood system. Please contact your authorized Southern Pride distributor for more details.

SITE INSTRUCTIONS (continued)

THROUGH THE WALL INSTALLATIONS (continued)

Illustrations of a through the wall installation.

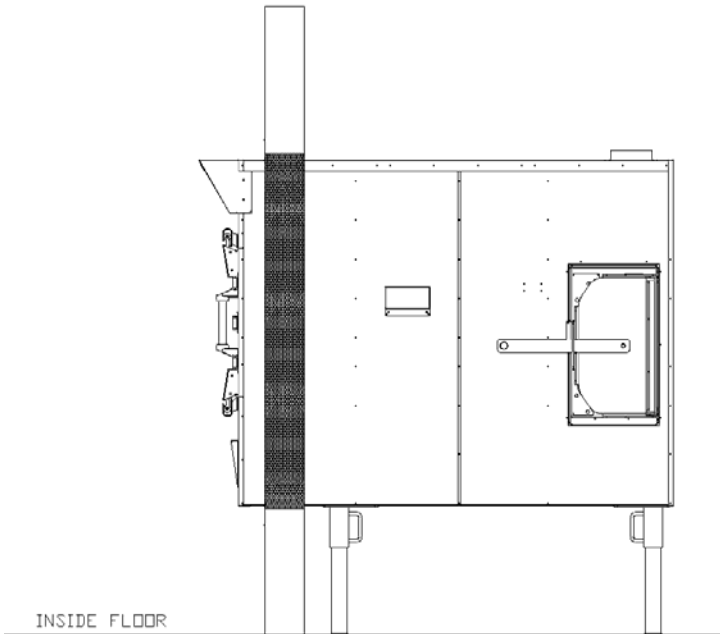
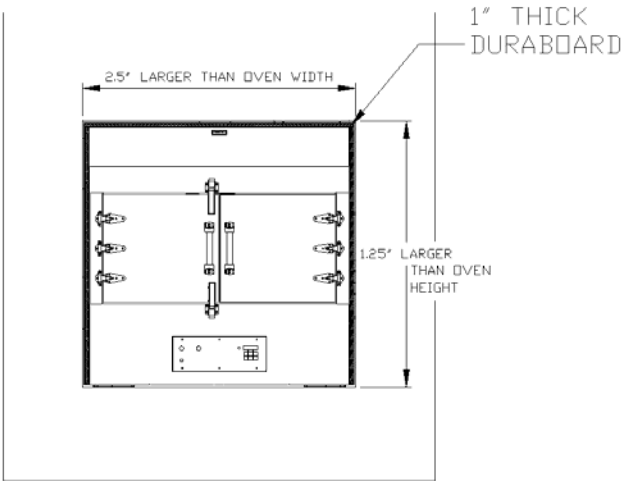
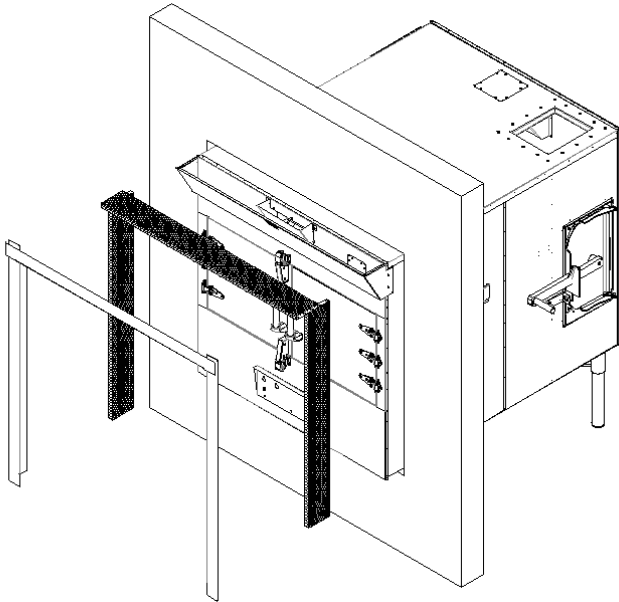
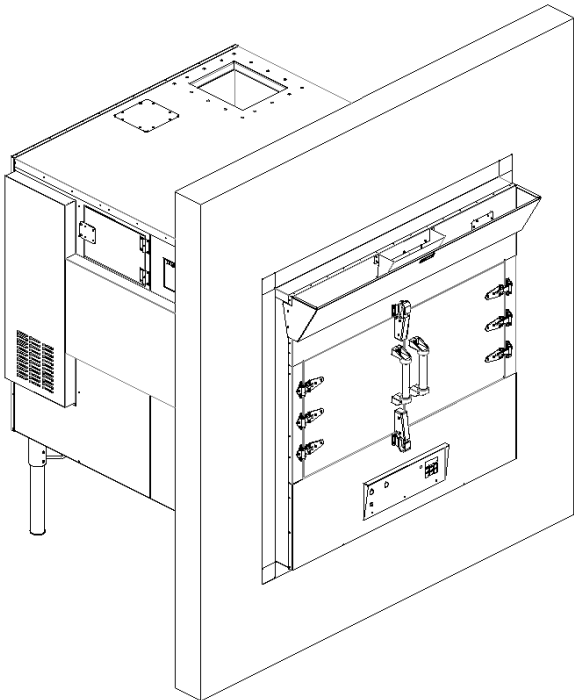

INSTALLATION INSTRUCTIONS

ELECTRICAL INSTRUCTIONS

Electrical Requirements:

- 120 volts AC, 60 Hz
- 2 wire, single phase
- 15 amp required, NEMA 5-15P plug



WARNING:

This appliance, when installed, must be electrically grounded in accordance with local codes, or in the absence of local codes, with the National Electrical Code, ANSI/NFPA 70, or the Canadian Electrical Code, CSA C22.2, as applicable.

THE WARRANTY IS VOID IF THE SMOKER IS CONNECTED TO ANY VOLTAGE OTHER THAN SPECIFIED ABOVE AND ON THE SMOKER DATA PLATE.

Remove all packing material before connecting the electrical and gas supply to the smoker.

1. An electrician must provide the conduit and wire for electrical hookup.
2. The power is to be left OFF throughout the installation.
3. The electrical service is connected via the factory supplied power cord normally located to the rear of the smoker on the service bay side. Alternatively, the power cord can be removed and the smoker hard wired.
4. On models equipped with an optional smoke extractor, the electrician must provide conduit and wire hookup from the junction box, located on the rear of the smoker, to the exhaust fan. Make the electrical connections inside the junction box.

NOTE: 125 V.A.C., 1/4 hp maximum connected load, 1100 CFM fan rating recommended for smokers equipped with the optional smoke extractor damper. Fans used in exhaust systems for commercial cooking shall be listed in accordance with UL 762.

5. If venting or gas connections are to be done at a later time, be sure that the power remains OFF.

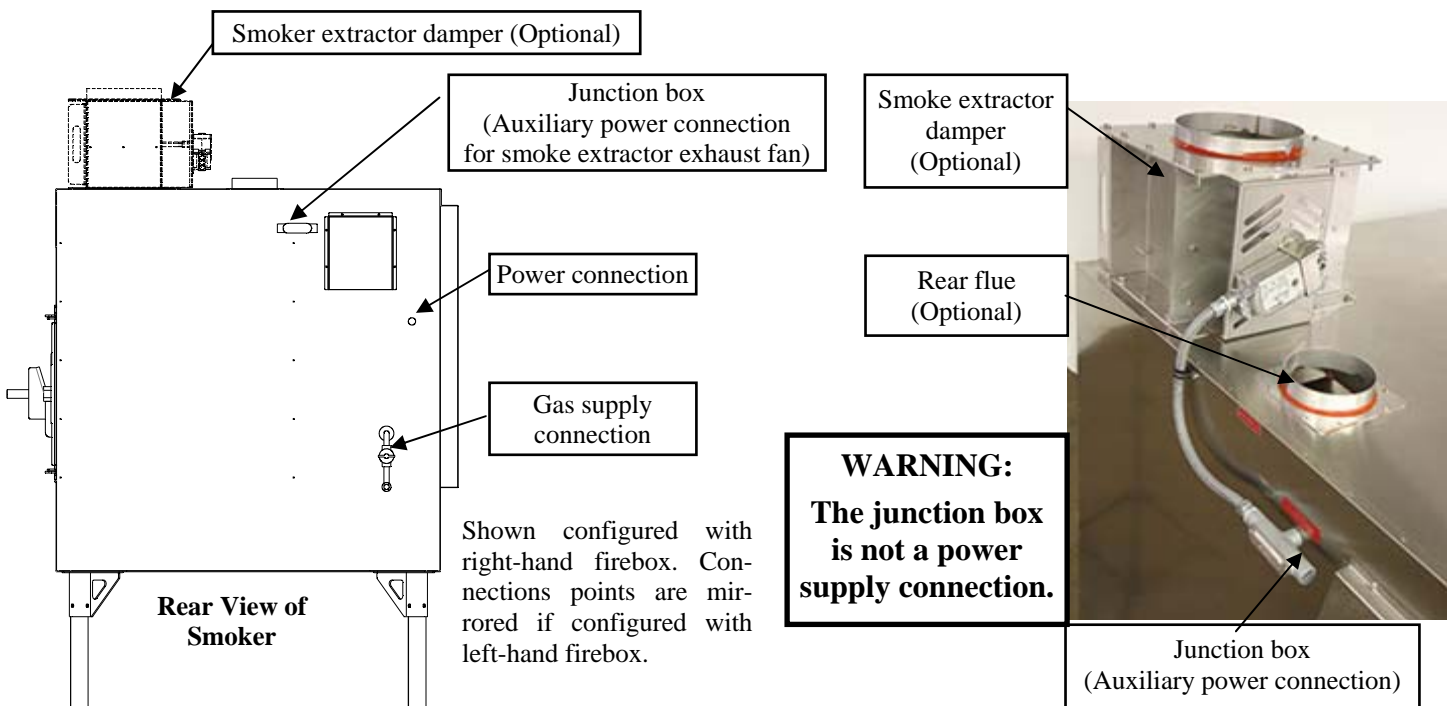

GAS PIPING INSTRUCTIONS

IMPORTANT NOTES TO THE INSTALLER

- Read all instructions contained in this Owner's Manual before making gas connections.
- Ensure all packing material is removed from the smoker compartments before connecting the gas supply to the smoker.
- Be sure your smoker is installed and grounded properly by a qualified service technician.
- Observe all governing codes and ordinances.

WARNING: IMPROPER GAS HOOKUP WILL VOID WARRANTY AND COULD RESULT IN A HAZARDOUS CONDITION.

1. All local and national codes and ordinances must be observed. Installation must conform with local codes or in the absence of codes, the National Fuel Gas Code ANSI Z223.1 / NFPA-54, latest edition available from The American Gas Association, Inc., 1515 Wilson Boulevard, Arlington, VA 22209.
2. The gas supply (service) line must be the same size or greater than the inlet line of the appliance. This smoker uses a 1/2" (1.3 cm) ID NPT (Sch40) inlet. Sealant on all pipe joints must be resistive to LP gas.
3. Supply line and manifold pressure should be checked with a manometer. Refer to page 17 for minimum and maximum pressures. Incoming line pressure upstream from the regulator must be 1" W.C.P. higher than the manifold pressure in order to check the regulator. The regulator used on this smoker can withstand a maximum input pressure of 1/2" PSI (14.0" W.C.P.). Over pressuring the valve may cause damage to the valve. If the line pressure is in excess of that amount, a step down regulator will be required.
4. It is recommended new pipe be used and located so that a minimum amount of work will be required in future servicing. The piping should be so installed as to be durable, substantial, and gas tight. It should be free from cutting burrs and defects in structure and threading. Cast iron fittings or aluminum tubing should not be used for the main gas circuit. Joint compounds (pipe dope) should be used sparingly on male threads only and be approved for all gases.

NOTE: The building structure should not be weakened by installation of the gas piping. The piping should not be supported by other piping, but should be firmly supported by pipe hooks, straps, bands, or hangers. Butt or lap welded pipe should not be bent.

5. **TEST PIPING FOR LEAKS.** Before turning gas under pressure into piping, all openings from which gas can escape must be closed. Immediately after turning on gas, the system should be checked for leaks. This can be done by watching the 1/2 cubic foot test dial for 5 minutes to show any movement, or by soaping each pipe connection and watching for bubbles. If a leak is found, make the necessary repairs and repeat the above test.

NOTE: Defective pipes or fittings should be replaced and not repaired. Never use a flame or fire of any form to locate gas leaks, use a soap solution.

6. After the piping and meter have been checked completely, **PURGE THE SYSTEM OF AIR. DO NOT** bleed the air inside the smoker. Be sure to relight all the gas pilots on other appliances.

NOTE: The burner and its individual shutoff valve must be disconnected from the gas supply piping system during any pressure testing in excess of 1/2 psig.

GAS PIPING INSTRUCTIONS

Pipe Sizing Chart for Natural Gas (0-0.5 psi) with Straight Schedule 40 Metal Pipe

The following chart is based on 0-0.5 psi inlet pressure, specific gravity of 0.6, and a pressure loss of 0.5" w.c.

Maximum Capacity of Pipe Size in Btu per Hour

Pipe Size	1/2"	3/4"	1"	1 1/4"	1 1/2"
Pipe Length (ft)	Maximum Capacity in Btu/hr				
10	175,000	360,000	680,000	1,400,000	2,100,000
20	120,000	250,000	465,000	950,000	1,460,000
30	97,000	200,000	375,000	770,000	1,180,000
40	82,000	170,000	320,000	660,000	990,000
50	73,000	151,000	285,000	580,000	900,000
60	66,000	138,000	260,000	530,000	810,000
70	61,000	125,000	240,000	490,000	750,000
80	57,000	118,000	220,000	460,000	690,000
90	53,000	110,000	205,000	430,000	650,000
100	50,000	103,000	195,000	400,000	620,000
150	40,000	84,000	160,000	325,000	500,000
200	35,000	72,000	135,000	280,000	430,000

Pipe Sizing Chart for Liquid Propane (11" w.c.) with Copper Tubing

The following chart is based on 11" w.c. inlet pressure and a pressure drop of 0.5" w.c.

NOTE: Copper tubing shall comply with standard type K or L of ASTM B 88 or STM B 280.

Maximum Capacity of Tube Size in Btu per Hour

Pipe Size	1/2"	5/8"	3/4"	7/8"
Pipe Length (ft)	Maximum Capacity in Btu/hr			
10	110,000	206,000	348,000	536,000
20	76,000	141,000	239,000	368,000
30	61,000	114,000	192,000	296,000
40	52,000	97,000	164,000	253,000
50	46,000	86,000	146,000	224,000
60	42,000	78,000	132,000	203,000
70	38,000	71,000	120,000	185,000
80	36,000	67,000	113,000	174,000
90	33,000	62,000	105,000	161,000
100	32,000	59,000	100,000	154,000

GAS PIPING INSTRUCTIONS (continued)

Pipe Sizing Chart for Liquid Propane (11" w.c.) with Straight Schedule 40 Metal Pipe

The following chart is based on 11" w.c. inlet pressure and a pressure drop of 0.5" w.c.

Maximum Capacity of Pipe Size in Btu per Hour

Pipe Size	1/2"	3/4"	1"	1 1/4"	1 1/2"	2"	3"
Actual ID	0.622	0.824	1.049	1.38	1.61	2.067	3.068
Pipe Length (ft)	Maximum Capacity in Btu/hr						
10	291,000	608,000	1,145,000	2,352,000	3,523,000	6,786,000	19,119,000
20	200,000	418,000	787,000	1,616,000	2,422,000	4,664,000	13,141,000
30	160,000	336,000	632,000	1,298,000	1,945,000	3,745,000	10,552,000
40	137,000	287,000	541,000	1,111,000	1,664,000	3,205,000	9,031,000
50	122,000	255,000	480,000	984,000	1,475,000	2,841,000	8,004,000
60	110,000	231,000	434,000	892,000	1,337,000	2,574,000	7,253,000
80	94,000	197,000	372,000	763,000	1,144,000	2,203,000	6,207,000
100	84,000	175,000	330,000	677,000	1,014,000	1,952,000	5,501,000
125	74,000	155,000	292,000	600,000	899,000	1,730,000	4,876,000
150	67,000	140,000	265,000	543,000	814,000	1,568,000	4,418,000
200	58,000	120,000	227,000	465,000	697,000	1,342,000	3,781,000
250	51,000	107,000	201,000	412,000	618,000	1,189,000	3,351,000
300	46,000	97,000	182,000	373,000	560,000	1,078,000	3,036,000
350	42,000	89,000	167,000	344,000	515,000	991,000	2,793,000
400	40,000	83,000	136,000	320,000	479,000	922,000	2,599,000

GAS CONNECTION INSTRUCTIONS

For smokers equipped with casters, the installation shall be made with a connector that complies with the Standard for Connectors for Movable Gas Appliances, ANSI Z21.69 CSA 6.16, and a quick-disconnect device that complies with the Standard for Quick-Disconnect Devices for Use With Gas Fuel, ANSI Z21.41 CSA 6.9.

Adequate means must be provided to limit the movement of the appliance without depending on the connector and the quick-disconnect device or its associated piping to limit the appliance movement.

The restraining device may be attached to the leg gusset of the leg nearest the gas connection.

WARNING: Operator should be aware that a restraint device is in place on smokers equipped with casters. If disconnection of the restraint is necessary, it must be reconnected after the appliance has been returned to its originally installed position.

IMPORTANT ITEMS TO CHECK BEFORE FIRING THE BURNER

1. Gas line **MUST** be installed by a qualified technician and in accordance with this Manual.
2. Gas line **MUST** include an easily accessible manual shutoff valve, drip leg, and pressure gauge port.
3. Gas pipe size **MUST** be in accordance with the Pipe Capacity Chart in this Manual (pages 14 and 15).
4. Gas line **MUST** be tested for leaks under pressure.
5. Gas line **MUST** be purged to remove any air in the system.
6. Gas line pressure **MUST** be checked and **MUST NOT** exceed the maximum pressure specified in the Burner Specifications on page 17.
7. Burner orifice **MUST** correlate with the type of gas being supplied, as specified in the Burner Specifications on page 17.



WARNING:

Improper gas hookup will void the warranty and could result in a hazardous condition.

BURNER SPECIFICATIONS

Burner Models: Wayne P265-EP (MLR models) / P250-EP (SPX, SPK and SP models)

Fuels: Natural or L.P. Gases

Electrical: 120 V.A.C., 60 Hz, 1 ph

NOTE: Orifice and valve setting must correlate with type of gas being supplied.

Firing Capacity				
Firing Rate Btu	65,000	75,000	125,000	150,000
MLR-150	X			
SPX-300		X		
SPK-500		X		
SP-700				X
MLR-850			X	
SPK-1000				X
SPK-1400				X

Main Orifice Size Chart		
65,000 Btu/hr	Natural Gas	#26 (.147")
65,000 Btu/hr	LP Gas	#43 (.089")
75,000 Btu/hr	Natural Gas	#19 (.166")
75,000 Btu/hr	LP Gas	#37 (.104")
125,000 Btu/hr	Natural Gas	#5 (.205")
125,000 Btu/hr	LP Gas	1/8" (.125")
150,000 Btu/hr	Natural Gas	#1 (.228")
150,000 Btu/hr	LP Gas	#29 (.136")

Pilot Orifice Size Chart	
Natural	BCR-24
LP	BCR-18

	Gas Supply Line Pressure		Manifold Pressure	
	Minimum	Maximum	Minimum	Maximum
Natural	4.5" w.c.	10.0" w.c.	3.0" w.c.	3.5" w.c.
LP	11.0" w.c.	13.0" w.c.	9.5" w.c.	10.0" w.c.

Gas valve: Control knob must be ON.

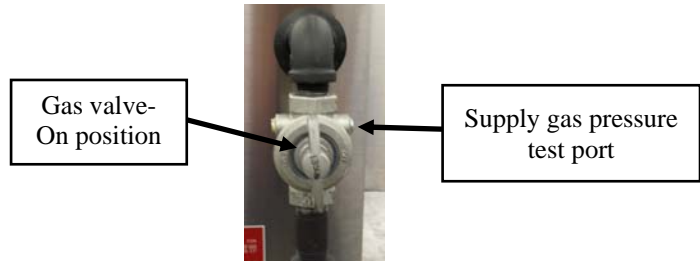

Wiring Diagram for Gas Burner

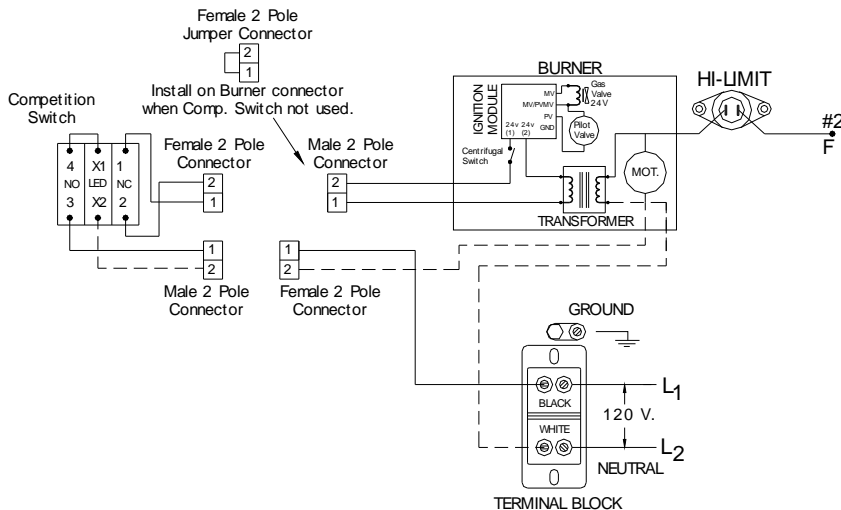

P-250EP Igniter Pilot Location

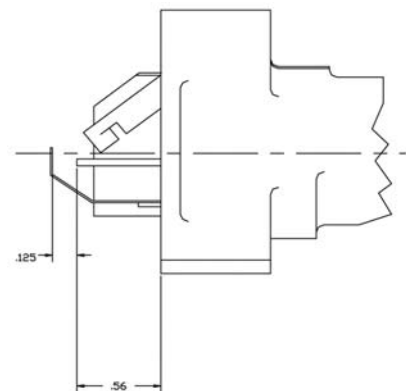

VENTING INSTRUCTIONS

THE METHOD OF VENTILATION MUST BE APPROVED BY THE LOCAL CODE ENFORCEMENT AGENCY PRIOR TO EQUIPMENT INSTALLATION.

1. The smoker ventilation system should comply with this manual and the current edition of NFPA® 96.
2. It is recommended that Local Code Officials and a Commercial Kitchen Ventilation Contractor be consulted prior to installation.
3. Provisions must be made for adequate air supply for the smoker. If the smoker is to be installed in a sealed room or building utilizing exhaust fans, the room must be supplied with a return air system. Return air must be equal or in excess of the exhausted air.
4. The smoker should be positioned to provide a direct, or shortest, path to the outside for the exhaust duct.

Minimum Clearance Requirement from Combustible Material

Back.....18" (457mm)	Firebox Door Side.....24" (610mm)
Top.....18" (457mm)	Service Bay Side.....18" (457mm)
Front.....48" (1219mm)	

NOTE: If provision is made for service access, Service Bay Side & Back clearance can be reduced to 2" (51mm).

OPTION 1: VSP EYEBROW HOOD SYSTEM

Optional VSP eyebrow hoods are purchased through an authorized Southern Pride distributor.

- VSP eyebrow hoods are UL Listed to the applicable Southern Pride smoker model and are NSF certified.
- **VSP eyebrow hoods can be utilized in stand-alone or through the wall applications.**
- Applications with a straight run exhaust length in excess of 30 feet between the VSP eyebrow hood and the fan assembly, and/or applications with more than one bend/elbow in the exhaust duct may require a fan with a larger horsepower motor.
- Exhaust fans larger than the VSP standard will require more than 120 volt power and/or 20 amps. Fans requiring additional power can not be powered by the smoker. Additional wiring will be required to properly power fans larger than the standard.
- The room in which the smoker and hood are installed will need an adequate make-up air system to replenish the air removed by the VSP eyebrow hood system. The exhaust fan will draw approximately 1,320 CFM of air on low speed, while the smoker is operating and approximately 2,000 CFM of air on high speed when the product loading doors are open.
- **CAUTION: Unbalanced air pressure can have an adverse effect on the performance of the smoker and the hood.**
- **Use of a VSP eyebrow hood requires the smoker to be a front flue configuration.**

VSP EYEBROW HOOD SYSTEM TO INCLUDE:

1. VSP eyebrow hood
2. Two-speed fan (1,320 CFM / 2,000 CFM)
3. Curb with vented extension and hinge kit (must specify roof pitch)
4. Grease capture trough

SUPPLIED BY CUSTOMER:

5. Duct from hood to fan
6. Hood system installation

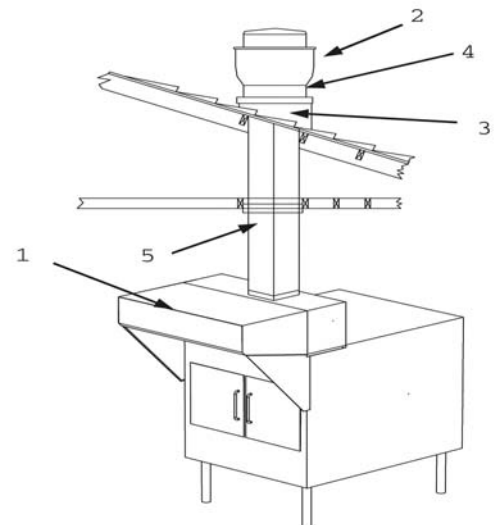

VENTING INSTRUCTIONS (continued)

OPTION 2: TYPE-1 CANOPY HOOD VENT

All smoker models may be installed under an approved Type-1 canopy hood system rated for commercial cooking appliances.

- Placement under a common hood shared with other appliances may be prohibited.
- NFPA® 96 specifies a minimum canopy overhang of 6 inches on all sides. Southern Pride recommends a minimum 18 inch overhang on the product loading door side of the smoker.
- Exhaust fan size must be determined by a ventilation contractor specifically for your application. Hood dimensions, exhaust duct length and routing all factor into the calculation.

OPTION 3: DIRECT VENT INSTALLATION (THROUGH THE WALL SHOWN)

With the purchase of the optional smoke extractor damper the smoker may be installed inside the building or through the wall and directly vented outside. The smoke extractor damper, along with a customer supplied exhaust fan and chimney, evacuates the smoke from the smoker prior to fully opening the product loading doors. When the doors are opened the smoker extractor damper and exhaust fan are activated to remove the smoke from the smoker.

- When installing a smoker through a wall constructed of combustible material, use the appropriate **Southern Pride Through the Wall Insulation Kit** between the smoker and the wall.
- The room that the smoker is installed into should have a balanced or slightly positive air pressure. If the room has negative air pressure smoke could escape from smoker into the room during operation.
- Use of a smoke extractor damper requires the smoker to be a rear flue configuration.

SUPPLIED BY CUSTOMER:



WARNING: NEVER use Class B vent for venting either the flue or the exhaust on the smoker.

- 6" all fuel chimney, or duct complying with NFPA® 96, for smoker flue
- 6" non-restrictive rain cap for smoker flue
- 10" all fuel chimney, or duct complying with NFPA® 96, for smoke extractor
- UL approved exhaust fan (1,100 CFM, 1/4 horsepower or less)
- Ventilation system installation

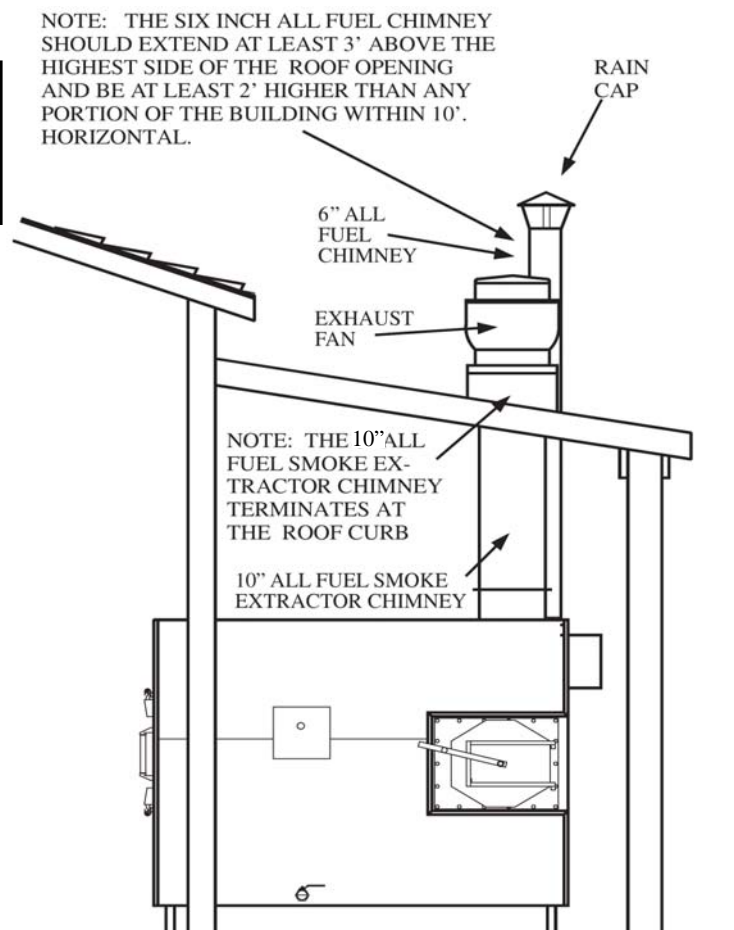

OPERATION

The smoker should be operated in the following order (with all operations according to the subsequent instructions):

1. Load the product into the smoker and close the product loading doors.
2. Place the desired wood into the firebox and close the firebox door.
3. Ensure that the drain valve is closed.
4. Set the control and start the cook cycle.
5. Once the cook cycle is complete, turn the control off.
6. Remove the product from the smoker.
7. Remove the ashes from the firebox.
8. Drain the grease from the smoker.

PRODUCT LOADING INSTRUCTIONS

1. Load product on the product racks. Product should be loaded from bottom to top on the product rack hangers. Also, the heaviest cuts of product should always be on the bottom product racks.

DO NOT LET PRODUCT EXTEND BEYOND OR HANG OVER THE EDGE OF THE RACKS.



CORRECT

The bottom rack is loaded first with the heavier cuts on bottom.



INCORRECT

Never load product on the top product rack only, always load product on the bottom product rack and then use as many of the product rack tiers above as needed.

2. To rotate the racks with the product doors open:
 - Standard digital control: Press the green rotisserie advance button.
 - Optional digital cook & hold control: Press the UP arrow button.
 - Either control: Step on the rotisserie advance foot pedal.
3. After the product is loaded, allow the rotisserie to make one complete revolution. The product racks should travel flat and level through the entire revolution, if they do not, reposition the product to balance the load and level the product racks. Check product clearances to cabinet and all racks. If necessary, reposition the product on the racks for maximum clearances.

FIREBOX LOADING INSTRUCTIONS

1. The solid fuel should be handled in accordance with NFPA® 96.
2. Ensure the control is OFF, or in the Idle or Pause position, before opening the firebox door.
3. Use 1-3 logs, 3-5 inches in diameter, 10-12 inches long. Use green or slightly seasoned hardwoods, fruitwoods, or charcoal (not to exceed six pounds). **THE WOOD OR CHARCOAL IS ONLY USED TO FLAVOR THE PRODUCT, NOT TO HEAT THE SMOKER.**
4. Be sure to keep the wood 4" from the burner or ashes can accumulate on the burner and cause it to not work properly.
5. Place the logs on top and inline with each other to minimize air flow around each log. This will help promote a smoldering, slow burn, which maximizes smoke.
6. The wood does not have to be lit manually; the smoker is equipped with a gas burner that will light the wood. Combustible or flammable liquids shall not be used to assist ignition.
7. Tightly close the firebox door to prevent air from being pulled into the firebox.
8. If the cook menu was paused, a press of the start button is required to resume the menu..

CAUTION:

- **Remove coals and ashes from previous cook cycle before loading new wood into the firebox. Refer to Ash Removal Instructions on page 23.**
- **Do not use dry wood or kindling.**
- **Do not overload firebox. Too much wood or charcoal can cause overheating of the smoker. Keep wood at least 4 inches from the burner.**
- **Do not allow ashes in or near the burner opening.**



CONTROL OPERATING INSTRUCTIONS

STANDARD DIGITAL THERMOSTAT

1. The product loading doors must be closed.
2. Turn the smoker power switch on. The control thermostat will come on and display the last temperature used or be off.
3. Use the up/down button on the control thermostat to set the desired temperature setting.
4. After a few seconds, the LED of the control thermostat will display the actual internal temperature of the smoker.
5. Press either the up or down button once to display the cook temperature.
6. At the end of the cook cycle, press the DOWN button on the control until "OFF" is displayed in the LED. When the control thermostat is off the gas burner will be OFF.

NOTE: The control thermostat does not control the length of the cook cycle; it will maintain the cook set point until it is turned off.

CONTROL OPERATING INSTRUCTIONS (continued)

OPTIONAL DIGITAL COOK & HOLD CONTROL

1. The product loading doors must be closed.
2. The control should be in the “IDLE” mode. (The burner, convection fan, and the rotisserie will be off). If the control is “OFF” a press of any button will bring the control back to “IDLE.”
3. A menu consists of a cook temperature, cook time, and, when the cook time has elapsed, a choice to end the menu (HOLD OFF) or go into hold mode (HOLD TEMP SETPOINT).
4. Press the cook temp button (tEnP 1 will appear in the LED display), then press the up/down buttons to obtain the desired cook temperature.
5. Press the cook time button (tinE1 will appear in the LED display), then press the up/down buttons to obtain the desired cook time.
6. Press the hold temp button (HtEnp will appear in the LED display), press the up/down buttons to obtain the desired hold temp, if a hold temp is not desired press the down button until “OFF” is displayed in the LED.
7. Programming the menu is complete. To start the menu, press the start/stop button one time. The control will begin the menu.
8. To cancel or stop the menu, press and hold the start/stop button until “IDLE” is displayed in the LED.
9. When the cook cycle is complete there are two possible actions that can be taken. One is if a hold temperature was programmed into the menu, the control will momentarily sound an audible alarm then, “HOLD” and the length of time the control has been in the hold mode will alternately flash in the LED display. The control will maintain the hold temperature until the start/stop button is depressed to “END” the menu, and bring the control to the “IDLE” mode.
10. If the hold temperature was programmed to “OFF” and the cook time has elapsed, “END” will be displayed on the LED display, and an audible alarm will sound continuously until the start/stop button is depressed, to “END” the menu, and bring the control to the “IDLE” mode.
11. After the control has been in the “IDLE” mode for five minutes it will go to “OFF”, a press of any button will bring the control back to “IDLE”.

OPTIONAL SMOKE EXTRACTOR DAMPER OPERATION

Standard Digital Thermostat:

- The smoke extractor damper and exhaust fan automatically activate when the product loading doors are opened. It is recommended to open the left product loading door enough to activate the smoke extractor system 45 seconds prior to fully opening the product loading doors to allow the smoke extractor system time to become fully functional before the product loading doors are opened.

Optional Digital Cook & Hold Control:

- The smoke extractor damper and exhaust fan automatically activate when the product loading doors are opened.
- When the menu is in progress a press of the down arrow button will activate the smoke extractor system. If the doors are not opened, the smoke extractor system will go off after one minute and the menu will resume. It is recommended to press the down arrow button 45 seconds prior to opening the product loading doors to allow the smoke extractor system time to become fully functional before the product loading doors are opened

PRODUCT UNLOADING INSTRUCTIONS

1. Before unloading the product, the control should be in the “OFF” or “IDLE” position.
2. Evacuate the smoke from the smoker before fully opening the product loading doors.
 - a. For smokers equipped with the optional smoke extractor, the smoke extractor will activate when the product loading doors are open.
 - b. For smokers equipped with the optional VSP hood system the hood system will automatically switch the fan to high-speed when the product loading doors are open.
3. Use the pneumatic foot pedal, the rotisserie advance button (standard control), or the up button (optional control) to advance the rotisserie and bring the desired product rack to the front of the smoker.
4. Product should be removed from top to bottom on the product rack hanger. This will prevent the rack from becoming unstable and tipping.

ASH REMOVAL INSTRUCTIONS

1. The ashes should be handled in accordance with NFPA® 96.
2. After each cook cycle, remove the remaining wood and hot coals from firebox. Use heat resistant gloves while handling ash container and ash removal tools.
3. Place small lots of them in a noncombustible corrosion resistant pan and spray with water. A noncombustible corrosion resistant pan should be kept just outside the firebox door for this purpose.
4. Once wood and ash have been sprayed, place them in a heavy metal container with a tight fitting metal lid (16 gauge minimum, capacity not to exceed 20 gallon). This container shall be assigned for this one purpose, shall be able to be handled easily by any employee assigned the task, and shall pass easily through any passageway to the outside of the building. The container shall always be covered when it is being moved through the premises. When any hole occurs in a container from corrosion or damage, the container shall be repaired or replaced immediately.
5. The ashes should be carried to a separate heavy metal container (or dumpster), outside the premises, that is used exclusively for the purpose of hot ash storage.

	<p>WARNING Never empty ash/coals from the smoker into a common trash dumpster. Embers from ash/coals could ignite materials resulting in a fire.</p>
---	---

	<p>CAUTION Be sure smoker product loading door(s) and firebox door are secured in the closed position immediately following a cook cycle and during non-use periods.</p>
---	---

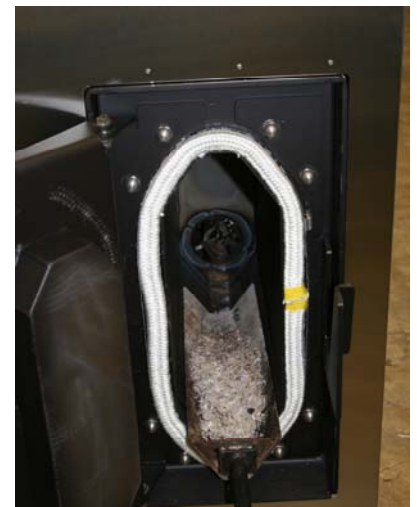

GREASE REMOVAL INSTRUCTIONS



WARNING

Do not connect the grease drain on the smoker directly to the building drain system or any other drain connection.



WARNING

Do not open the drain valve while the smoker is still in operation or while burning wood and hot coals are still in firebox.

1. Immediately drain the grease after each cook cycle.
2. Place a container under the grease drain valve located below the smoker.
3. Open the valve slowly. Caution: Grease may be HOT.
4. Grease should be poured into an approved grease recycling bin.



WOOD STORAGE INSTRUCTIONS

- The solid fuel should be stored in accordance with NFPA® 96.
- Wood stored in the same room as the smoker or the smoker firebox door shall not exceed a 1-day supply.
- Wood shall not be stored above any heat-producing appliance or vent or closer than 0.92 m (3ft) to any portion of a solid fuel appliance constructed of metal or to any other cooking appliance that could ignite the wood.
- Wood shall not be stored in the path of ash removal.
- Where stored in the same building as the smoker, wood shall be stored only in an area with walls, floor and ceiling of noncombustible construction extending at least 0.92m (3ft) past the outside dimension of the storage pile.
- Wood shall be separated from all flammable liquids, all ignition sources, all chemicals, and all product supplies and packaging goods.
- All wood storage areas shall be provided with a sprinkler system meeting the requirements of NFPA® 13.

Exceptions:

- Where acceptable to the authority having jurisdiction, wood storage areas shall be permitted to be protected with a fixed water pipe system with a hose capable of reaching all parts of the area.
- In lieu of a sprinkler system a listed 2-A rated water spray extinguisher or a 6 L (1.6 gal) wet chemical fire extinguisher listed for Class K fires with a maximum travel distance of 6 m (20 ft.) to the wood piles shall be permitted to be used for a wood pile, provided that the wood pile does not exceed 0.14 cubic meters (5 cubic feet) volume.

MOBILE SMOKER OPERATION

- **LP tanks are shipped empty.** Have the tanks filled by a licensed professional before using. Inform your LP supplier that the tanks are new and **need to be purged before filling.**
- Check the fuel level of the LP tanks prior to starting a cook cycle. Proper monitoring of the LP tanks will eliminate the chance of running out of gas.
- The burner in the smoker is equipped with an automatic ignition system. **Do not attempt to manually light the burner.**
- Do not transport the smoker while the smoker is in operation or with product on the product racks.
- Disconnect the electrical power supply before removing the service compartment access panels for servicing.
- Do not transport the smoker with hot coals or a wood fire in the firebox.
- Never place anything over the flue of the smoker, it must be unobstructed to work properly.
- Never attempt to cook with the product door(s), firebox door, or the grease drain valve open.
- **Dry wood, too much wood, or too much charcoal may cause the temperature in the smoker to override the thermostat setting.** Follow instructions in this manual for the proper amount of wood or charcoal to use.

MOBILE SMOKER ELECTRICAL INFORMATION

This smoker is equipped with a power cord with a 3 prong grounded plug. DO NOT cut or remove the grounding prong from the smoker power cord or from any extension cord used with the smoker.

The smoker should only be plugged into a 120 VAC, 15 amp, grounded receptacle.

Use only a 3 prong grounded extension cord rated for outdoor use marked with a “w” (formerly w-A). This designation indicates the cord is rated for outdoor use and includes sunlight resistant jacket and wet location rated conductors.

MOBILE SMOKER WARNINGS

GENERAL

1. Mobile smokers are intended for outdoor use. NEVER use in a garage, building, shed, breezeway or other enclosed area. The mobile smoker shall not be used under any overhead combustible construction.
2. Store your smoker in a well-ventilated area. If stored indoors, detach and leave LP cylinders outdoors in a well-ventilated area away from heat and away from where children may tamper with them.
3. Keep the electrical supply cord and the fuel supply hose away from any heated surfaces.
4. Do not remove service compartment access panels when smoker is in operation or leave off during operation.
5. After a period of storage or nonuse, check the smoker for gas leaks and burner obstructions before use.
6. Wheel chocks must be used when the smoker is sitting stationary.
7. Inspect the mobile rack retainer pins and clips to ensure the rack hangers are locked prior to transport.
8. Level the smoker, both front to back and side to side, before operating the smoker.

MOBILE SMOKER WARNINGS (continued)

ELECTRICAL

1. To protect against electrical shock:
 - a) do not immerse any part of the power cord, plug or extension cord in water or any other liquid.
 - b) use only a 3 prong extension cord, and only plug into a 15 amp grounded receptacle.
2. Unplug the smoker from the outlet when not in use and before cleaning.
3. Do not let the extension cord hang over the edge of a table or touch hot surfaces. Keep the cord out of walkways to avoid a tripping hazard.
4. Do not use this smoker for purposes other than intended.
5. Do not operate this smoker with a damaged cord, plug, or after the smoker malfunctions or has been damaged in any manner.

LP GAS

1. The LP cylinders must be constructed and marked in accordance with the specifications for LP gas cylinders by the U.S. Department of Transportation (DOT), or CAN/CSA B339.
2. The handling, storage and transportation of gas cylinders must be in accordance with storage and handling of Liquid Petroleum Gases, ANSI/NFPA 58 or Natural Gas and Propane Installation Code, CSA B149.1.
3. Do not change the regulator/hose assembly or use any assembly other than the one supplied with your smoker.
4. Cylinders must be secured using the provided cylinder retention system to avoid accidental movement. Exchange only for Type 1, 40lb cylinders with over-fill protection devices. Never use a cylinder with a damaged valve. A dented or rusty LP cylinder may be hazardous and should be avoided. If in doubt, have the cylinder checked by your LP supplier. Always check for leaks after every LP cylinder change.
5. Always shut off the LP gas supply at the cylinder when the smoker is not in use.
6. Cylinders must be stored outdoors in a well-ventilated area out of the reach of children. If your smoker is stored indoors, the LP cylinder must be removed and stored outside. LP gas cylinders are not to be stored in any compartment on the smoker that is not intended for cylinder storage. Such unauthorized storage could lead to an explosion, fire, or personal injury.
7. Cylinders should not be allowed to remain in a high heat area such as a closed car, trunk, or in direct sunlight.

MOBILE SMOKER WARNINGS (continued)

LP GAS (continued)

8. Before each use, inspect the gas hose. If excessive abrasion, wear or if the hose is cut it must be replaced prior to the smoker being put into operation.
9. LEAK TESTING: Do not use a flame to check for a gas leak. To prevent fire or explosion hazard, DO NOT smoke or allow any potential source of ignition (sparks, electrical arcing, etc.) in the area while performing a leak test. Leak tests should be conducted outdoors only.
 - a. Create a soapy solution of 1 part soap and 1 part water, or use a gas leak detector solution available for purchase from a plumbing supply or hardware store. Confirm that all control knobs are in the off position.
 - b. Open the gas supply valves and apply the soap solution generously by paint brush or squirt bottle on all connections and fittings. If bubbles appear to “grow” on any of the connections, you have a gas leak, immediately turn off the gas supply.
10. Fixing a gas leak: Wash off the soapy solution with cold water and dry. Tighten the loose joint, or replace the faulty part with manufacturer-recommended replacement parts.
11. Do not attempt to repair the LP cylinder valve if it is damaged. The only way to safely resolve a damaged cylinder is to replace it.
12. Repeat the leak test to ensure that no leaks are present.
13. Do not operate the smoker if there is a gas leak present.
14. Leaking gas may cause a fire or explosion which can cause serious bodily injury or death.
15. When not in use, the gas valve on the LP tanks must be turned off and the supply line disconnected from the tanks. The protective dust cap must be installed on the valve outlet.
16. Liquid propane is not natural gas. The conversion to or attempted use of natural gas in a liquid propane smoker is dangerous and will void your warranty.
17. Do not attempt to disconnect any gas fitting while your smoker is in operation.
18. Although your liquid propane cylinder may appear to be empty, gas may still be present. The cylinder should be transported and stored with the valve closed.

PROPANE TANK OPERATION

REMOVING A PROPANE TANK FROM THE ASSEMBLY STAND

1. Turn off both tanks, by turning the valve knobs in a clockwise direction to close.
2. Remove the LP pigtails, by turning the nuts in a counter clockwise direction to loosen.
3. The protective dust cap must be installed on the valve outlet.
4. Loosen the wing nut on the tank lock bar and lift up the regulator bracket. Lift the locking bar to free it from the top ring of the tanks and turn it 90° from the locked position.
5. Lift the cylinder straight up to remove.

INSTALLING A PROPANE TANK INTO THE DUAL TANK STAND

1. Lower tank into the stand base, making sure the tank is sitting firmly in the base.
2. Lift and turn lock bar into slots of the top ring of the tank, making sure it is fully engaged in the ring of both tanks.
3. Confirm the tab of the regulator bracket is locked into the slot in the top of the lock bar. Tighten the wing nut until the lock bar is securely holding the tanks in place.
4. Lift tanks by handle and wiggle them to confirm they are fastened down securely, retightening wing nut if necessary.
5. Remove the protective dust cap and attach the LP Pigtails. Turn knob clockwise to tighten.
6. Slowly open gas valves and check for gas leaks.

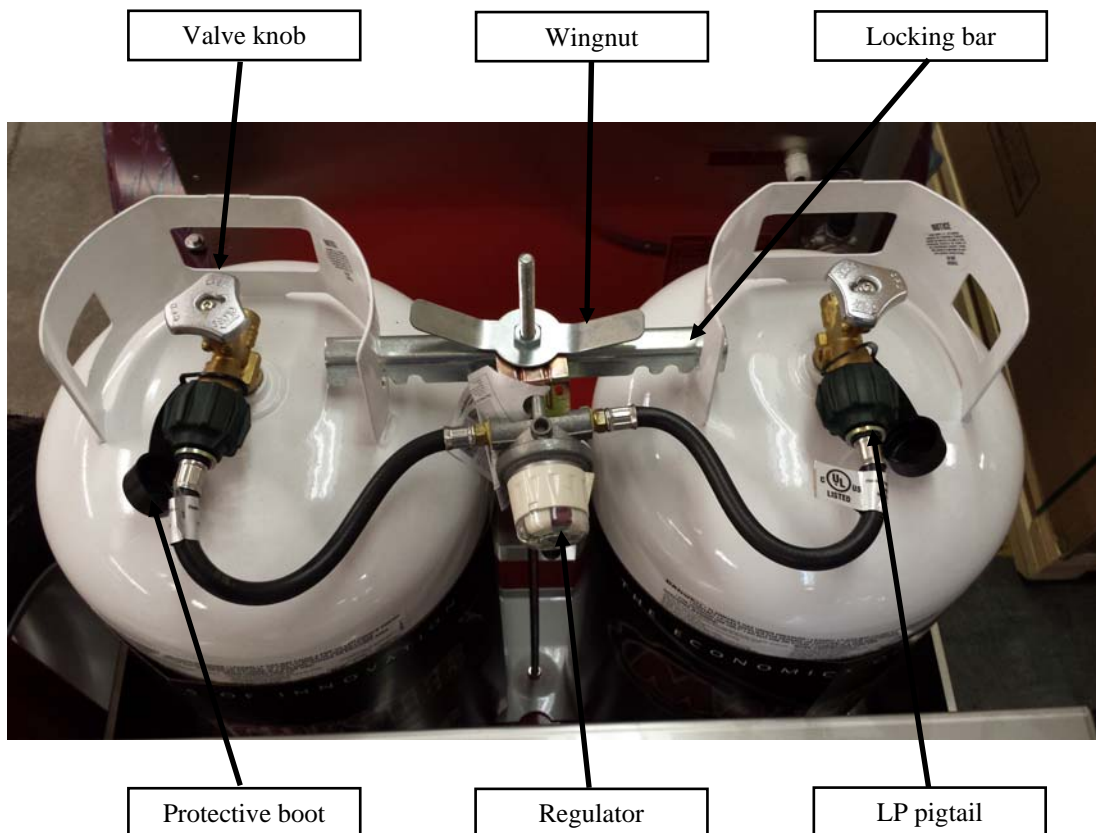

LP DUAL TANK ASSEMBLY INFORMATION

The Type I pigtail consists of a green nylon swivel nut attached to a hose by a brass nipple. The nylon nut is designed for easy grip and features a right-handed 1-15/16" ACME thread. The ACME thread allows a smooth, convenient connection that does not require tools.

The nut swivels on a thermally sensitive sleeve that is engineered to yield when it reaches temperatures between 240°F and 300°F. This yielding allows a back-check in the cylinder valve to close, shutting off the flow of gas from the cylinder.

The Type I pigtail also contains a flow-limiting feature specifically designed for the RV application. If there is catastrophic damage to the regulator of the LP gas system, the device senses the higher rate of gas flow and shuts down to a flow rate of 10 SCFH or less. However, it is not designed to detect all leaks, or totally shut off the system in the event of a leak or failure of the system. Under certain conditions, such as when a cylinder valve is opened, this flow control device will activate, causing a restriction in the supply of fuel to appliances. The flow control mechanism will automatically reset within a few seconds (once the pressure has equalized in the system), provided there are no leaks in the system and all appliances have been turned off.

To remedy a low or restricted flow condition, the following procedures should be followed each time the cylinder is opened or restricted flow is evident (for example low flame or yellow flame at burner):

1. Turn main power switch on the smoker to off.
2. Open the LP gas cylinder valve slowly. **DO NOT SNAP OPEN.**
3. Be sure all connections have been tested with a soapy solution (non-ammonia dish washing liquid) or leak detector solution. **CAUTION:** Never use a match or other flame to check for leaks.
4. Wait at least 15 seconds before turning the smoker back on.
5. If operational difficulties continue, have the system inspected by a qualified LP technician.

CHANGEOVER REGULATOR INFORMATION

The changeover regulator offers the convenience of changeover from empty to full gas cylinders.

Make sure there is propane in both cylinders before you start. Rotate the white knob on the front side of the regulator until the indicator arrow points toward the cylinder you want to use first. This will be the "service" cylinder and the other will be the "reserve" cylinder. Slowly open BOTH cylinder valves. The indicator in the knob of the regulator will turn bright green. The indicator color will stay green as long as there is fuel coming from the service cylinder. When the service cylinder empties, the regulator will start drawing from the reserve cylinder providing an uninterrupted fuel flow to the system. When it switches over, the indicator color changes from green to red. This red color indicates that the service cylinder is empty and needs to be filled. To remove the empty cylinder, rotate the knob halfway between the two cylinders, the indicator will turn green, and the reserve cylinder becomes the service cylinder. Next, shut off the cylinder valve on the empty cylinder. Turn the knob the rest of the way to the reserve cylinder, the reserve cylinder is now the service cylinder. Now disconnect the empty cylinder and have it refilled. After refilling, reconnect the pigtail and slowly open the cylinder valve. The full cylinder now becomes the reserve cylinder. Check that all connections are tight and there is no gas leak, by using a soap and water solution as described on page 27 to check for a gas leak in this manual.

How to keep your regulator operating efficiently and safely

The regulator comes with a protective cover in place to protect the regulator vent from freezing rain, snow, etc. collecting over the vent hole of the regulator. It is important to check the vent frequently to be sure it is clean and free of water, corrosion, or obstruction, as clogging is a potential cause of regulator malfunction. In the event the vent does become clogged, it can easily be cleaned with a toothbrush. In addition, your regulator should be checked periodically by a competent LP service technician to be sure it is properly adjusted and in safe working condition.

What is Regulator Freeze Up?

A regulator will not freeze, nor will LP gas, under normal atmospheric conditions. However, as the gas passes through the regulator it expands and cools and moisture in the gas or in the regulator may turn to ice. This ice can build up and totally or partially block the orifice, and thus partially or totally block the fuel supply. There are a number of things you can do to prevent this type of freeze up:

1. Be sure your LP cylinder is totally free of moisture before it is filled.
2. Be sure your cylinder is not over filled, this is particularly important if you have a permanently mounted ASME tank.
3. Keep the valves on empty cylinders closed.
4. Have your LP gas dealer purge the cylinder if freeze up occurs.
5. Have your LP gas dealer inject methyl alcohol in your cylinder.

MAINTENANCE SCHEDULE



WARNING

It is extremely important to follow the below maintenance procedures. Grease or solids buildup inside the smoker could result in a fire hazard.



WARNING:

Before any service is performed on the smoker, the gas supply should be turned off and the power disconnected.

DAILY:

1. Remove all product racks and product rack hangers from smoker and take to sink area for cleaning. Use a commercial foodservice detergent / degreaser. Follow the product manufacturer's instructions for proper use, cautions and warnings. Protective gear such as goggles and rubber gloves should be used.
2. Sanitize product racks and product rack hangers with a commercial product service sanitizer. Follow the product manufacturer's instructions for proper use, cautions and warnings. Protective gear such as goggles and rubber gloves should be used.
3. Drain grease daily. Refer to the Grease Removal Instructions on page 24 of this manual.
4. Remove ashes and coals from firebox after each cook cycle. Refer to the Ash Removal Instructions on page 23 of this manual.

WEEKLY:

1. Remove and clean the product door latches.
 - a. After the smoker has been turned off and given time to cool, open the product door(s) leaving the roller in the down position.
 - b. Using a crescent wrench on the top edge of the latch cover, apply force to the crescent wrench towards the smoker to pop the bottom of the latch cover free, and then the latch can be lifted up and away from the backing plate.
 - c. TO RE-INSTALL: Position the door latch, with the roller in the up position, over the backing plate, fastening the hooks on the latch over the tabs on the backing plate. Using the palm of your hand, push the bottom of the latch into the backing plate until it locks in position.



a.



b.



c.



CAUTION:

The latch rollers are spring-loaded and will open quickly with a lot of force. Do not pinch a finger or hand.

MAINTENANCE SCHEDULE (continued)

WEEKLY (continued):

2. Inspect the burner head for accumulation of ashes. If ashes are present, clean immediately. Ashes in the burner head can cause the burner to misfire. Inspect the interior walls of the firebox and scrape off any solids or creosote buildup in accordance with NFPA® 96.



3. Inspect the product door and firebox door gaskets. Replace if damaged or leaking.



4. The flue shall be inspected weekly for the following conditions in accordance with NFPA® 96:
 - a. Residue that might begin to restrict the vent or create an additional fuel source. The flue or chimney should be cleaned before these conditions exist.
 - b. Corrosion or physical damage that might reduce the flue's capacity to contain effluent. The flue or chimney shall be repaired or replaced if any unsafe condition is evident.
5. Filters and filtration devices installed in a hood shall be cleaned prior to them becoming heavily contaminated and restricted.



6. The combustion chamber shall be scraped clean to its original surface once each week and shall be inspected for deterioration or defects.

MAINTENANCE SCHEDULE (continued)

MONTHLY:

1. Inspect the convection fan blade for solids or creosote buildup or an out-of-balance condition. Clean as needed. **WARNING: Solids buildup will cause the fan blade to be out of balance and, if not cleaned, can cause damage to the fan blade and to the convection fan motor. An extra fan blade is shipped with the smoker and is located inside the service compartment.**

WARNING: Oven MUST be off and power disconnected before opening service door.

Models: MLR-150, SPX-300, SPK-500, MLR-850 and SPK-1000

Remove the left 2 bolts with a 5/16" socket and open the convection fan access door.



Loosen the set screw and remove the fan blade for cleaning.
Set Screw Sizes:
MLR-150 - 5/32"
SPX-300 - 5/32"
SPK-500 - 5/32"
MLR-850 - 5/16"
SPK-1000 - 5/16"

Models: SP-700 and SPK-1400. After removing convection fan cover on the back of the smoker:

Remove the top 2 and bottom 2 bolts with a 1/2" socket and open the convection fan access door.

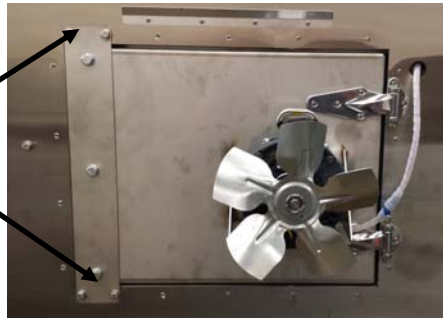

Loosen the set screw and remove the fan blade for cleaning.
Set Screw Sizes:
SP-700 - 5/16"
SPK-1400 - 5/16"

2. Inspect the proximity switch on the top part of the product door frame. Make sure the area is clean and free of debris.



3. Check the thermostat thermocouple. Be sure there is no solids or creosote buildup. Clean as needed.

Thermostat thermocouple on the left side of the interior of the smoker.



Rotisserie wheel stub.

MAINTENANCE SCHEDULE (continued)

MONTHLY (continued):

4. Check the Teflon sleeves on the rotisserie wheel stubs. Clean or replace if damaged or worn. Check and tighten the wheel stub bolts and nuts, if needed.
5. Check the product door hinges and the product door latches. Tighten screws and align as needed.

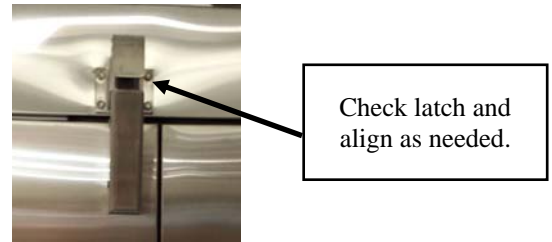
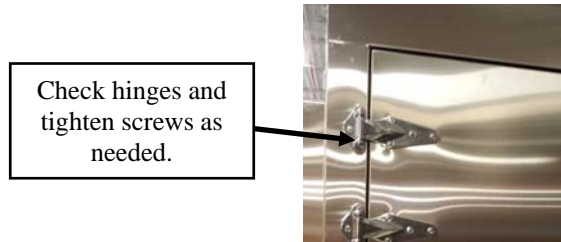

6. For smokers equipped with the optional smoke extractor, the damper inside of the smoke extractor should be checked for any solids or creosote buildup. To inspect the smoke extractor damper, the damper should be in the open position and the following steps should be followed:

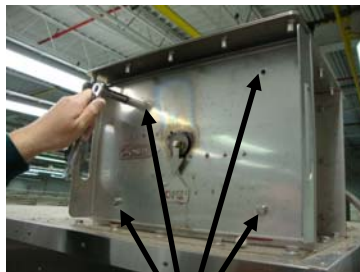

1. Remove 4 bolts with a 7/16" socket for access.



2. Pull the damper assembly out of the smoke extractor.



3. Inspect the damper and inside walls for solids or creosote buildup.

Reassemble the smoke extractor in the reverse order.

QUARTERLY:

1. Remove the drive system cover and service compartment cover and check the retainer and set screws on the small and large sprockets. Tighten if needed. All models except the SPK-1400.
2. Scrape creosote buildup off of the firebox side of the baffle board.

Models: MLR-150, SPX-300, SPK-500, MLR-850 and SPK-1000 - From inside of the smoker.

View from product loading doors.



Baffle board.

Models: SP-700 and SPK-1400 - From inside of the smoker or through the convection fan access door.

MAINTENANCE SCHEDULE (continued)

ANNUALLY:

Lubricate the drive chain (all models except the SPK-1400). Disconnect the power supply and remove the drive system cover from the smoker. Using a clean brush and quality SAE 20 oil, lubricate the chain.

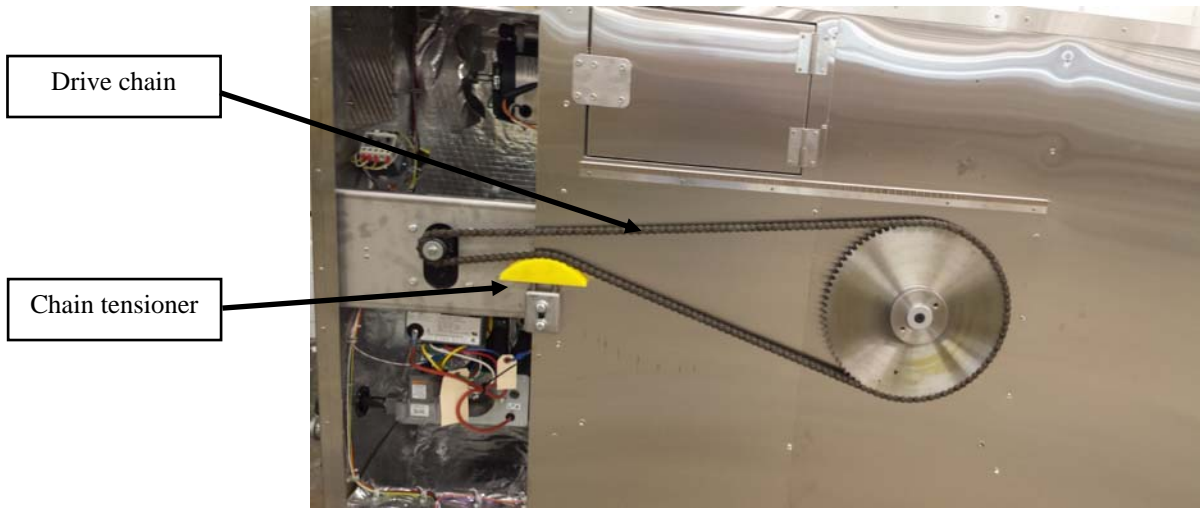

NOTE: Model SPK-500 shown. Models SPK-500, SP-700, MLR-850 and SPK-1000 have a chain tensioner. The chain tensioner is a spring-loaded tensioner that should not need to be adjusted. Models MLR-150 and SPX-300 have a turnbuckle system to properly tension the drive chain.

SEMI - ANNUALLY:

Have an experienced service technician inspect and clean the burner electrode. Southern Pride recommends replacing the burner electrode every 12-18 months, depending on usage.

MAINTENANCE SCHEDULE (continued)

AS NEEDED:

(Frequency will depend on usage and local health department's requirements):



WARNING

It is extremely important to follow the below maintenance procedures. Grease or solids buildup inside the smoker could result in a fire hazard.

INTERIOR:

- Use a commercial product service detergent/degreaser to clean the smoker interior. Follow the product manufacturer's instructions for proper use, cautions and warnings. Protective gear such as goggles and rubber gloves should be used. **Note: Avoid the use of abrasive cleaning compounds, chloride based cleaners, or cleaners containing quaternary salts. Never use hydrochloric acid (muriatic acid) on stainless steel.**
- Smoker should be cool. Do not try to put cleaner on smoker when hot.
- While product racks and product rack hangers are out of the smoker apply cleaner to the smoker interior: walls, ceiling, floor, rotisserie wheels and shaft and allow to soak for 10 minutes.
- Thoroughly rinse smoker interior with water using a water hose or pressure washer. **(Do not directly pressure wash the convection fan blade; the fan blade should be removed for cleaning).**
- Drain waste water; place a container under the drain valve and slowly open valve. Dispose of rinse water according to local environmental requirements.
- Inspect the interior of the smoker for any areas that did not come clean; repeat the cleaning procedure in those areas.
- Thoroughly rinse the interior of the smoker and drain.
- Sanitize the smoker interior: walls, ceiling, floor, rotisserie wheels and shaft, and convection fan with a commercial product service sanitizer. Follow the product manufacturer's instructions for proper use, cautions and warnings. Protective gear such as goggles and rubber gloves should be used. Wet all surfaces using a cloth or sprayer. Allow to remain wet for 10 minutes.
- Rinse surfaces by wiping with a cloth and clean warm water, and dry with a clean, soft cloth.
- To dry interior of the smoker leave product door(s) open and allow to air dry.

Note: Consult with the appropriate state or local health department regarding all applicable cleaning and sanitation requirements for equipment.

MAINTENANCE SCHEDULE (continued)

AS NEEDED:

(Frequency will depend on usage and local health department's requirements):

STAINLESS STEEL SURFACES:

Use non-abrasive cleaning products for use on stainless steel surfaces. Cleaning agents must be chloride-free compounds and must not contain quaternary salts. Never use hydrochloric acid (muriatic acid) on stainless steel surfaces. Always use the proper cleaning agent at the manufacturer's recommended strength.

EXTERIOR:

Southern Pride BBQ Smokers are known for their attractive appearance. We achieve this by selecting only the finest grade of type 304 stainless steel and applying exacting workmanship.

- All of the exterior of the smoker can be cleaned with a mild soap and water solution.
- Before cleaning the smoker, make sure it is turned off, main power switch off, and power cord disconnected from power.
- On mobile smokers, turn off LP gas.
- If the smoker is HOT from use, allow adequate time for it to cool down (approximately 1 hour).
- After the smoker exterior has been washed, apply a stainless steel polish cleaner to all surfaces.
- Wipe control panel, door handles, and door gaskets thoroughly, since these areas harbor food debris.
- **Do not use scotch bright pads or scouring pads to clean the outside of your smoker. If a non-abrasive scouring pad must be used, make certain to scrub with the visible grain of the surface metal to avoid scratches.**

Caution: Some cleaning products are not suitable for stainless steel; be sure to read the label before use.

GAS SMOKER WIRING DIAGRAM WITH STANDARD CONTROL

REV 2

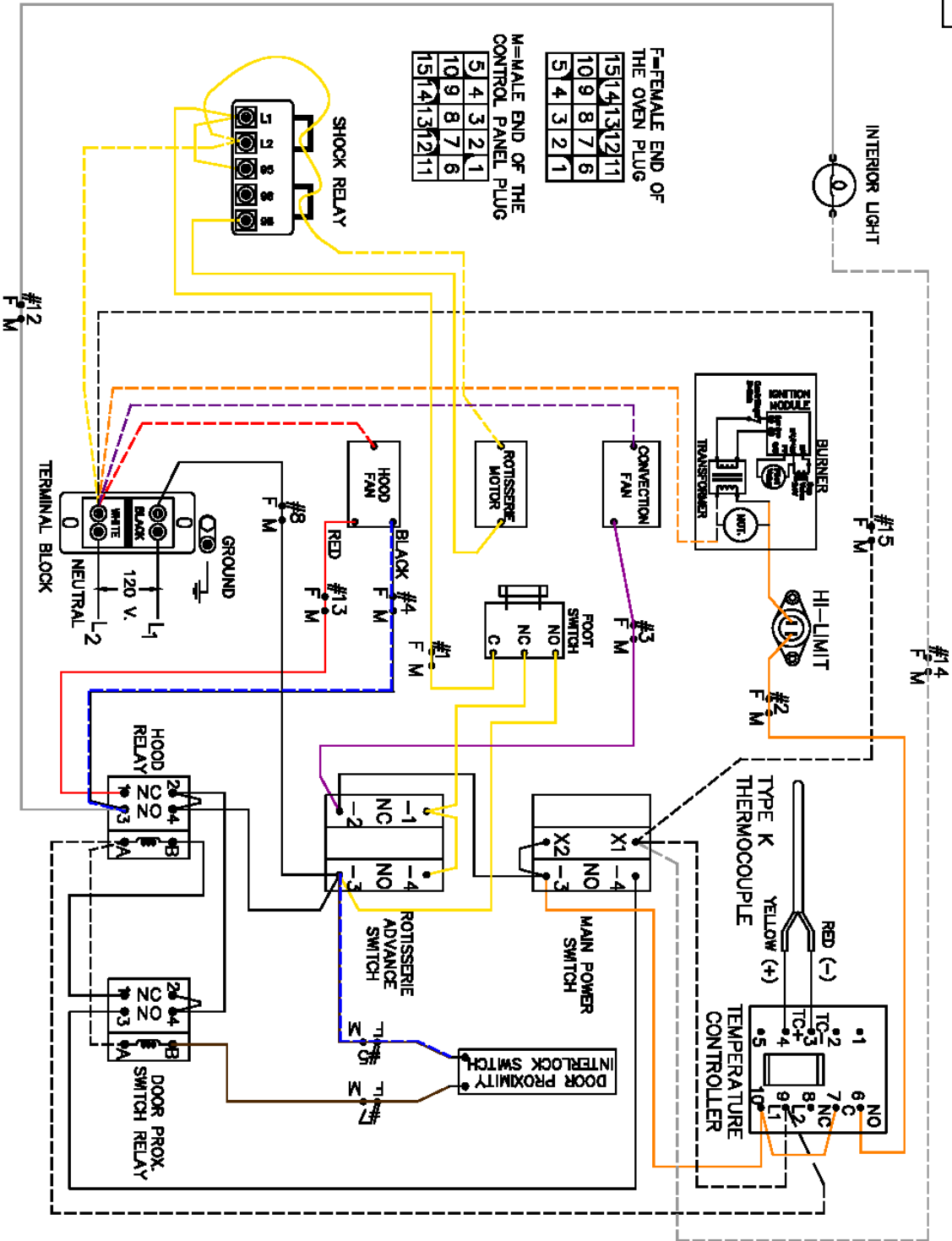

F= FEMALE END OF THE OVEN PLUG
 15 14 13 12 11
 10 9 8 7 6
 5 4 3 2 1

M= MALE END OF THE CONTROL PANEL PLUG
 5 4 3 2 1
 10 9 8 7 6
 15 14 13 12 11

Wire Color Code Legend		
White w/ Gray Stripes	White	Brown
White w/ Yellow Stripes	Yellow	Gray
White w/ Orange Stripes	Orange	
White w/ Purple Stripes	Purple	
White w/ Red Stripes	Black	
Black w/ Blue Stripes	Brown w/ Blue Stripes	

NOTE: If using the optional VSP hood to vent the smoker, the smoker should be plugged into a switched receptacle to be able to shut off the hood.

GAS SMOKER WIRING DIAGRAM WITH STANDARD CONTROL INCLUDING COMPETITION SWITCH AND GLASS DOOR LIGHT SWITCH

REV 3

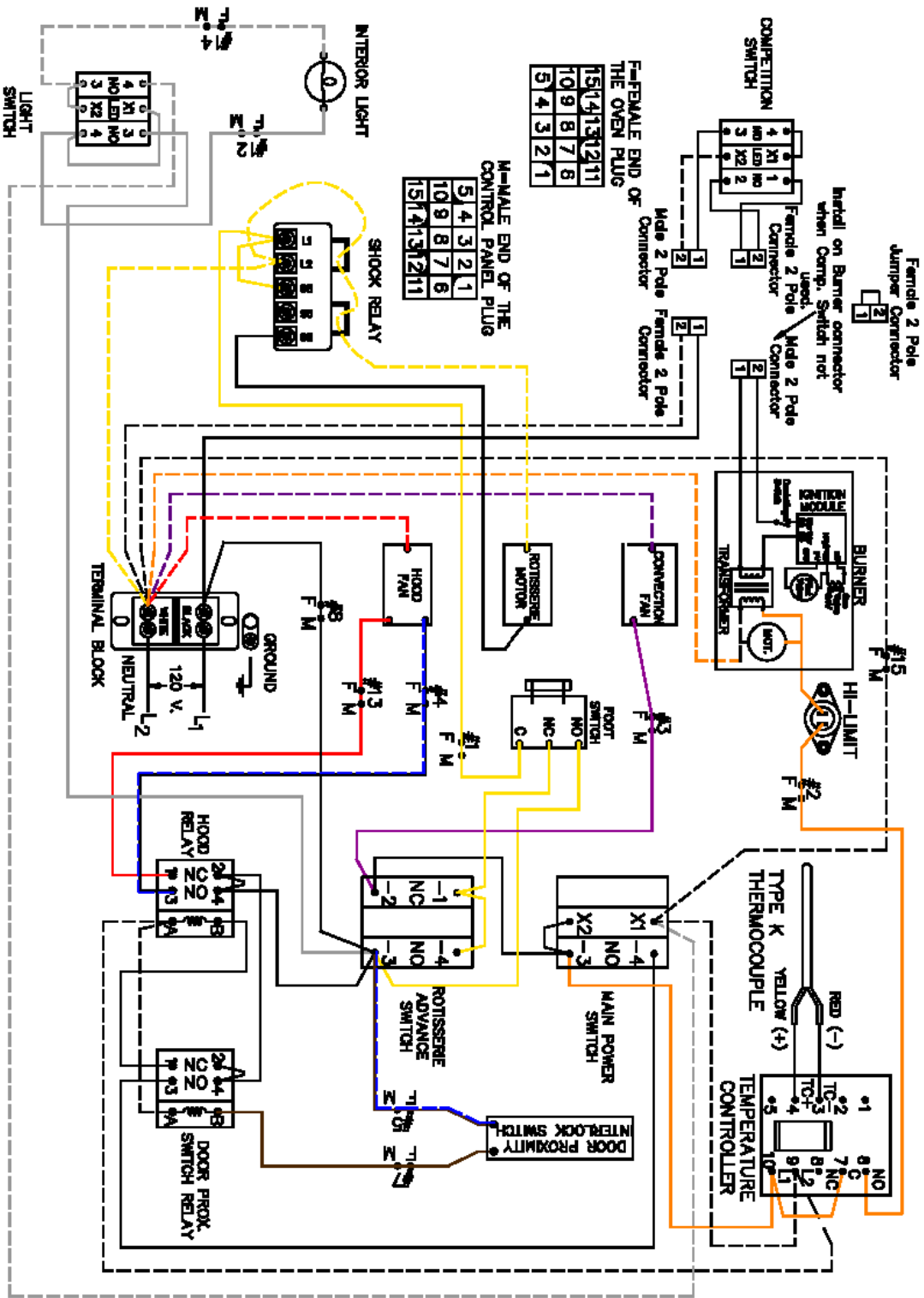

Wire Color Code Legend		
- - - White w/ Gray Stripes	- - - White	— Brown
- - - White w/ Yellow Stripes	— Yellow	— Grey
- - - White w/ Orange Stripes	— Orange	
- - - White w/ Purple Stripes	— Purple	
- - - White w/ Red	— Black	
— Black w/ Blue	— Brown w/ Blue	

NOTE: If using the optional VSP hood to vent the smoker, the smoker should be plugged into a switched receptacle to be able to shut off the hood.

GAS SMOKER WIRING DIAGRAM WITH DIGITAL COOK AND HOLD CONTROL

REV 5

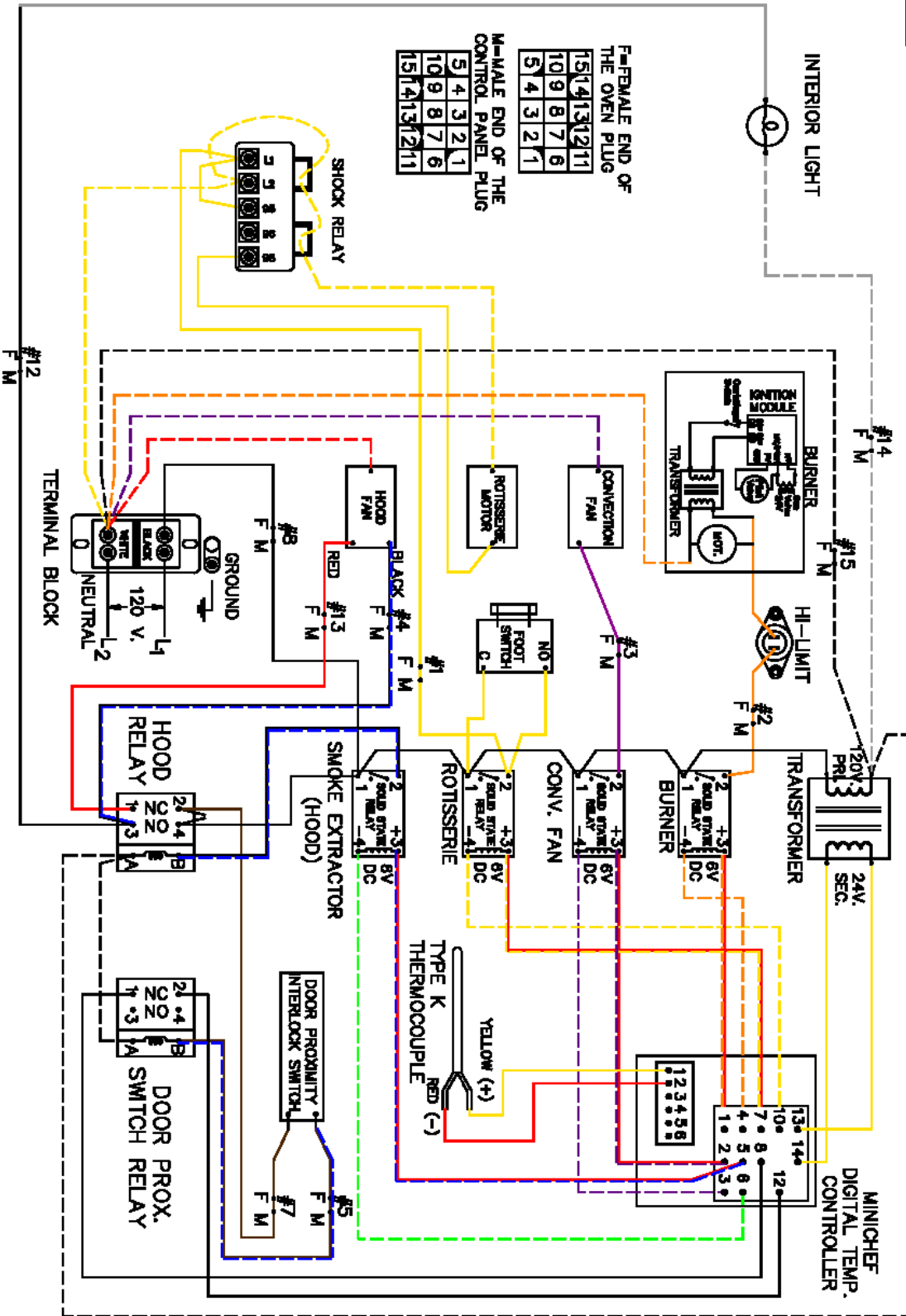

FEMALE END OF THE OVEN PLUG

15	14	13	12	11
10	9	8	7	6
5	4	3	2	1

M-MALE END OF THE CONTROL PANEL PLUG

5	4	3	2	1
10	9	8	7	6
15	14	13	12	11

Wire Color Code Legend		---	---
---	White	---	White
---	White w/ Gray Stripe	---	Yellow
---	White w/ Yellow Stripe	---	Orange
---	White w/ Orange Stripe	---	Purple
---	White w/ Purple Stripe	---	Black
---	White w/ Green Stripe	---	Brown w/ Blue
---	White w/ Red Stripe	---	Black w/ Blue
---	Red w/ Blue Stripe	---	Red w/ Purple
---	Red w/ Orange	---	Red w/ Yellow
---		---	Brown
---		---	Grey

NOTE: If using the optional VSP hood to vent the smoker, the smoker should be plugged into a switched receptacle to be able to shut off the hood.

GAS SMOKER WIRING DIAGRAM WITH DIGITAL COOK AND HOLD CONTROL INCLUDING COMPETITION SWITCH AND GLASS DOOR LIGHT SWITCH

REV 3

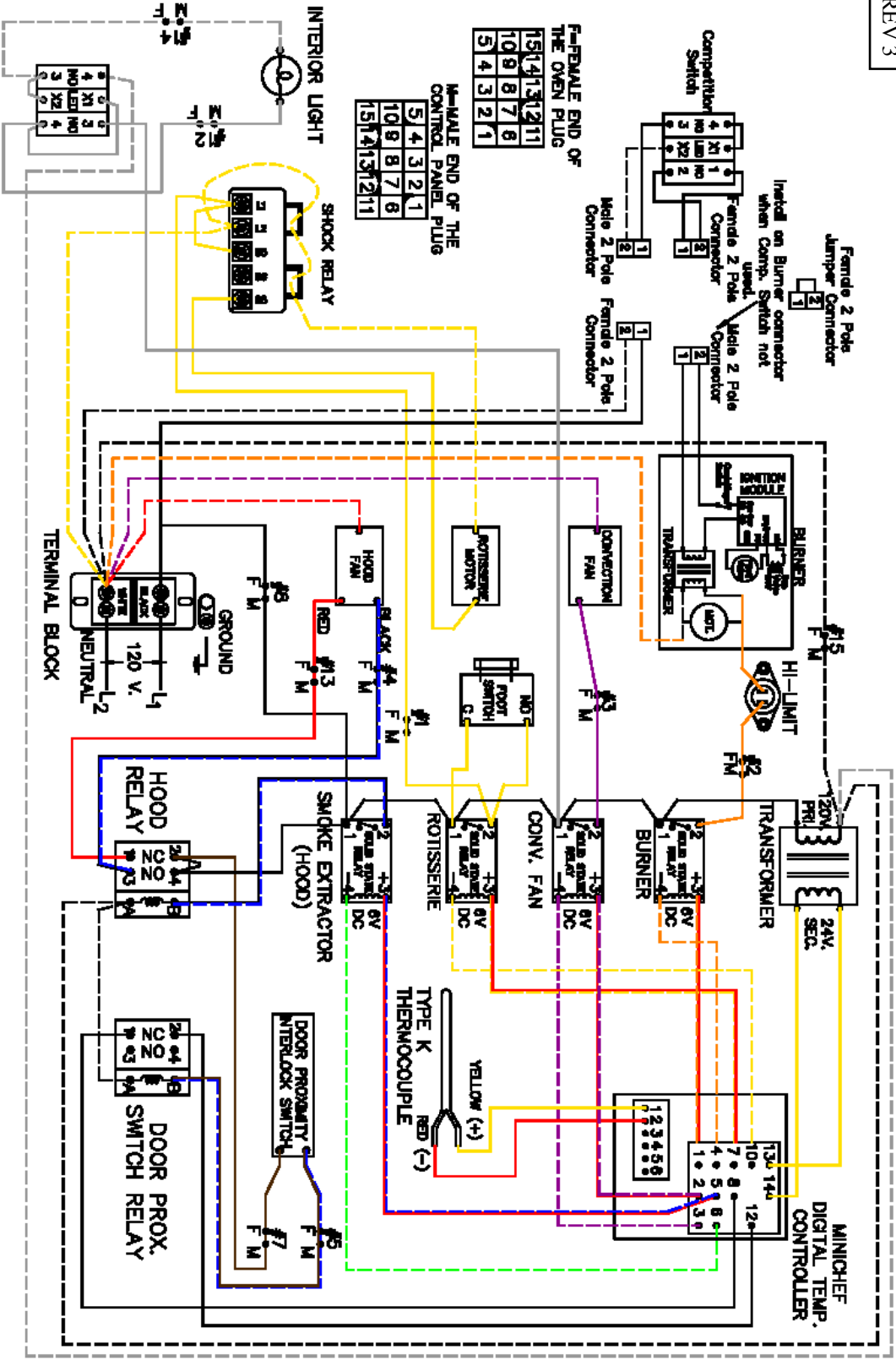

Wire Color Code Legend		Brown
--- White	--- Yellow	---
--- White w/ Gray Stripes	--- Orange	---
--- White w/ Yellow Stripes	--- Purple	---
--- White w/ Orange Stripes	--- Black	---
--- White w/ Purple Stripes	--- Brown w/ Blue	---
--- White w/ Green Stripes	--- Black w/ Blue	---
--- White w/ Red Stripes	--- Red w/ Purple	---
--- Red w/ Blue Stripes	--- Red w/ Yellow	---
--- Red w/ Orange		

NOTE: If using the optional VSP hood to vent the smoker, the smoker should be plugged into a switched receptacle to be able to shut off the hood.

REPLACEMENT PARTS LIST

	MLR-150	SPX-300	SPK-500	SP-700	MLR-850	SPK-1000	SPK-1400
Gaskets							
Product door	070088	070080	070081	070089	070090	070076	070101
Firebox door	071015	071013	071012	071016	071017	071011	071018
Rotisserie							
Axle bearing	331001 (1")	331001 (1")	332001 (1 3/16")	332002 (1 1/2")	332001 (1 3/16")	332002 (1 1/2")	333001 (2")
Gear motor	351002	351001	351001	351004	351004	351004	353006
Small sprocket	372001	372008	372008	372009	372009	372009	N/A
Large sprocket	372002	372012	372011	372013	372013	372013	N/A
Electrical							
Digital thermostat (standard)	432001	432001	432001	432001	432001	432001	432001
Cook & hold control (optional)	431020	431020	431020	431020	431020	431020	431020
Bi-metal high limit	434002	434002	434002	434002	434002	434002	434002
Type "K" thermocouple	435001 (1")	435001 (1")	435001 (1")	435001 (1")	435001 (1")	435001 (1")	435001 (1")
Main power switch	441035	441035	441035	441035	441035	441035	441035
Rotisserie advance switch	441045	441045	441045	441045	441045	441045	441045
Shock relay	442011	442011	442011	442011	442011	442011	442011
Door interlock switch	444015	444015	444015	444015	444015	444015	444015
Convection							
Fan motor	522001	522001	522001	522001	522001	522001	522001
Fan blade	532004 (8")	532004 (8")	532004 (8")	532011 (12")	532010 (10")	532010 (10")	532011 (12")
Burner							
Transformer	582005	582005	582005	582005	582005	582005	582005
Blower motor	582008	582008	582008	582008	582008	582008	582008
Gas valve	582010 (Nat.) 582016 (LP)	582010 (Nat.) 582016 (LP)	582010 (Nat.) 582016 (LP)	582010 (Nat.) 582016 (LP)	582010 (Nat.) 582016 (LP)	582010 (Nat.) 582016 (LP)	582010 (Nat.) 582016 (LP)
Electrode/pilot assembly	582011 (Nat.) 582015 (LP)	582011 (Nat.) 582015 (LP)	582011 (Nat.) 582015 (LP)	582011 (Nat.) 582015 (LP)	582011 (Nat.) 582015 (LP)	582011 (Nat.) 582015 (LP)	582011 (Nat.) 582015 (LP)
High voltage lead	582012	582012	582012	582012	582012	582012	582012
Ignition control module	582019	582019	582019	582019	582019	582019	582019

REPLACEMENT PARTS LIST

	MLR-150	SPX-300	SPK-500	SP-700	MLR-850	SPK-1000	SPK-1400
Door Hinges/Closers							
Product door hinge	870003	870003	870003	870003	870003	870003	870003
Mechanical door closer	771001	771001	771001	771001	771001	771001	771001
Mechanical door closer latch	771002	771002	771003	771004	771005	771006	771007
Product Racks/Hangers							
Teflon wheel stub	315013	351003	351003	351003	315013	351003	351003
Nickel chrome product rack	970021 (10" x 22")	970011 (12" x 30")	970017 (12" x 42")	970014 (12" x 48")	970015 (18" x 22")	970020 (18" x 42")	970017 (12" x 42") 970020 (18" x 42")
Stainless steel product rack	971013 (10" x 22")	971006 (12" x 30")	971010 (12" x 42")	971008 (12" x 48")	971009 (18" x 22")	971011 (18" x 42")	971010 (12" x 42") 971011 (18" x 42")
Hanger rack	994002	994010	994007	994018	994016	994008	994024 (12") 994025 (18", 5 tier) 994026 (18", 4 tier)

BEFORE YOU CALL FOR SERVICE



WARNING:

Before any service is performed on the smoker, the gas supply should be turned off and the power disconnected.

GENERAL

SYMPTOM	WHAT TO DO
Smoker does not start	<ul style="list-style-type: none"> • Product loading door(s) must be closed. • Check that the power cord is plugged into a live outlet. • Check that the main power switch is on (standard control). • Check that the menu is programmed and the Start/Stop button has been pressed (optional control).
Noise inside the smoker	<ul style="list-style-type: none"> • Check and clean the convection fan blade.
Rotisserie keeps rotating when product doors are opened	<ul style="list-style-type: none"> • Check door proximity switch.
Rotisserie does not rotate	<ul style="list-style-type: none"> • Check shock relay and reset by opening and closing product loading doors if tripped. • Check drive motor belt (only model SPK-1400).
Rotisserie moves when smoker is off	<ul style="list-style-type: none"> • Check that the rotisserie drive motor brake is engaged (all models except SPK-1400).

COLD WEATHER SMOKER OPERATION

When temperatures drop below freezing there are issues that may develop. Listed below are some of those issues and ways to correct or reduce the effects of the problem.

SYMPTOM	WHAT TO DO
Grease in the drain solidifies	<ul style="list-style-type: none"> • Drain the smoker after every cook cycle to purge the drainpipe of liquids before they solidify. • Wrap the drain pipe with electric heat tape and/or insulating heat pipe and tape.
Error 7 appears on the digital cook and hold control	<ul style="list-style-type: none"> • Wet a cloth with warm water and hold it against the thermocouple located on the left inside wall of the smoker for 20-30 seconds.

TROUBLESHOOTING THE GAS BURNER



WARNING:

Gas burners require an experienced technician for proper service and adjustment. If the burner does not appear to be operating properly, **DO NOT ATTEMPT TO ADJUST THE BURNER YOURSELF**, but call in a competent service technician.

GAS BURNER SEQUENCE OF OPERATION

It is very important to know the sequence of operation when troubleshooting the burner. The below steps describe the cycle for ignition in the sequence of operation for the burner.

1. The smoker is powered on with the desired cooking temperature set.
2. At a call for heat from the thermostat, 120 volts of power go through the thermostat, the high limit switch, and on to the burner.
3. The power comes into the burner at the junction box, which is located on top of the blower motor; 120 volts AC go to the primary side of the 24 volt AC step down transformer and to the combustion motor and the combustion motor comes on.
4. The step down transformer sends 24 volts AC out to the centrifugal switch on the blower motor.
5. When the blower motor is powered up and reaches full speed, the centrifugal switch (located on the end of the motor) is activated, sending 24 volts through it and on to the ignition control module.
6. When 24 volts reaches the ignition control module, it sends a high voltage spark out to the electrode (igniter) to light the pilot flame, and at the same time, it sends 24 volts to open the pilot valve on the main gas valve.
7. After the pilot lights, the electrode (igniter) acts as a flame sensor sending a DC micro amp signal back to the control module that there is a pilot flame, then the ignition control module sends out 24 volts AC to open the main valve.
8. The pilot flame lights the flow of gas from the main valve and the burner will fire until the call for heat from the thermostat has been satisfied, shutting the burner down.

NOTE: The burner is equipped with a ignition module that has a 3-try for ignition sequence.

TROUBLESHOOTING GUIDE

SYMPTOM	WHAT TO DO
Blower motor does not run	<ul style="list-style-type: none">• Check for 120v present at the blower motor.
Burner does not fire	<ul style="list-style-type: none">• Check for 24 volts at the ignition control module.• Clean the centrifugal switch.• Check the condition of the ignition wire.• Clean the electrode and check the spark gap (1/8”).
Burner sparks, but does not fire	<ul style="list-style-type: none">• Remove any ash in the burner head.• Check that the gas is turned on.• Check the supply line pressure. (see page 17).• Clean the electrode.
Pilot lights, but burner does not	<ul style="list-style-type: none">• Check for loose wire connection at the valve and control module.• Clean the igniter rod.
Pilot lights, but does not stay lit	<ul style="list-style-type: none">• Check the igniter-sensor probe and wire.

LIMITED WARRANTY

Southern Pride Distributing, LLC (“Southern Pride”) warrants to the original purchaser that any original part found to be defective in material or workmanship will, at Southern Pride’s option, subject to provisions hereinafter stated, be replaced with a new or rebuilt part. The labor warranty, provided only in the U.S.A., remains in effect one (1) year from installation or fifteen (15) months from the shipping date, whichever occurs first. Southern Pride will bear normal labor charges performed by an authorized Southern Pride service agent during standard business hours, and excluding overtime, holiday rates or any additional fees. The parts warranty remains in effect for one (1) year from installation or fifteen (15) months from the shipping date, whichever occurs first. All warranty parts ship via standard ground delivery service.

This warranty does not cover the following:

- Improper installation, delivery or maintenance.
- Failure of the Product if it is abused, misused, or used for other than intended purpose.
- Products which are not defective or broken, or which are working as described in the Owner’s Manual.
- Damage to the Product caused by accident, fire, floods, or acts of God.
- Damage caused by services performed by unauthorized service companies.
- Service calls to correct the installation of your Product or to instruct you how to use your Product.
- Expenses for making the Product accessible for servicing.
- Replacement of consumable parts; belts, gaskets, light bulbs, etc.

NO IMPLIED WARRANTY, REPRESENTATION OR CONDITION

To the extent permitted by law, neither Southern Pride nor any company/individual affiliated with it makes any warranties, representations, conditions or promises express or implied as to the quality, performance or freedom from defect of the smokers covered by these warranties other than those set forth above, and **NO STATUTORY OR IMPLIED WARRANTIES OR CONDITIONS OF MERCHANTABILITY OR APPLICABLE PERIOD OF WARRANTY SET FORTH ON THIS PAGE. THE PURCHASER’S ONLY REMEDIES IN CONNECTION WITH THE BREACH OR PERFORMANCE OF ANY WARRANTY ON THE PRODUCTS ARE THOSE SET FORTH ON THIS PAGE. IN NO EVENT WILL SOUTHERN PRIDE OR ANY COMPANY/INDIVIDUAL AFFILIATED WITH IT BE LIABLE FOR INCIDENTAL OR CONSEQUENTIAL DAMAGES.** In no event shall Southern Pride be liable for loss of use, loss of revenue or profit, or loss of product, or for any indirect, incidental or consequential damages.

LIMITATION OF LIABILITY

Southern Pride will not be liable under any circumstances for any incidental, consequential or special damages, including without limitation any lost profits or labor costs, arising from the sale, use or installation of the products, from the products being incorporated into or becoming a component of another product or from any other cause whatsoever, whether based on warranty (expressed or implied) or otherwise based on contract, on tort or any other theory of liability, and regardless of any advice or representations not in writing that may have been rendered by Southern Pride concerning the sale, use or installation of the products. In the event the above warranty fails to correct purchaser’s performance problems caused by defects in workmanship and/or materials, purchaser’s exclusive remedy shall be limited to payment by Southern Pride of actual damages in an amount not to exceed the amount paid for the smoker

IF YOU NEED SERVICE

To secure warranty service, the purchaser must (1) report the equipment defect to their authorized Southern Pride distributor and request warranty service within the applicable warranty term; (2) present evidence of the warranty start date with a valid proof of purchase; and (3) make the Product available within a reasonable time.

Should your problem not be solved to your complete satisfaction by your authorized Southern Pride distributor, you should contact Southern Pride at PO Box 354, Alamo, TN 38001, Phone: 1-800-437-2679. When contacting the manufacturer, the following information will be requested: (a) Model and serial number of the Product, (b) Address where the Product is installed, (c) Name and address of the installer and any service agency that performed service on the Product, (d) Date of original installation and dates any service work was performed, (e) Details of the problems as you can best describe them, (f) List of people, with dates, who have been contacted regarding your problem.