

# Toastmaster<sup>®</sup>

## Electric Griddle

Owner's Manual

### Models

TMGE24, TMGE36, TMGE48

This manual includes material related to installation, use, cleaning, and care. Exploded view[s], as well as any available parts list[s] and wiring diagram[s] pertaining to the unit[s] covered by this manual are also included.

This manual must be read and understood by all persons using or installing this appliance. Contact your Star dealer if you have any questions concerning installation, use, or maintenance of this equipment.

**DO NOT DISCARD THIS MANUAL.**

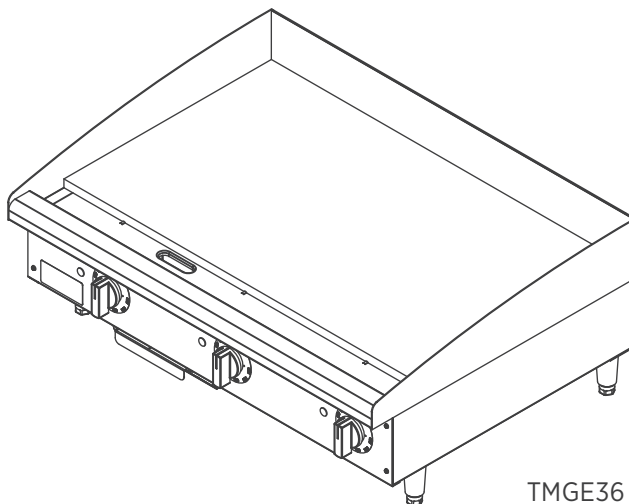

TMGE36



#### LIMITED EQUIPMENT WARRANTY

All workmanship and material in Toastmaster products have a one (1) year limited warranty on parts and labor in the United States and Canada. Such warranty is limited to the original purchaser only and shall be effective from the date the equipment is placed in service. Toastmaster's obligation under this warranty is limited to the repair of defects without charge, by the factory authorized service agency or one of its sub-agencies. Toastmaster will not assume any responsibility for loss of revenue. Models that are considered "portable" (see below) should be taken to the closest Toastmaster service agency, transportation prepaid. On all shipments outside the U.S.A. and Canada, see the International Warranty.

This warranty does not apply to any item that is disassembled or tampered with for any purpose other than repair by an authorized service center or the service center's sub-agency. This warranty does not apply if damage occurs from improper installation, misuse, wrong voltage, wrong gas or operated contrary to the Installation and operating instructions. This warranty does not apply to "Special Products" but to regular catalog items only. Toastmaster's warranty on "Special Products" is six (6) months on parts and ninety (90) days on labor.

#### PARTS WARRANTY

Parts that are sold to repair out of warranty equipment are warranted for ninety (90) days. The labor to replace the part is NOT warranted.

#### SERVICES AND EXPENSES NOT COVERED BY WARRANTY

- Travel time and mileage rendered beyond the 50-mile radius limit
- Mileage and travel time on "portable" equipment (see below)
- Labor to replace such items that can be replaced easily during a daily cleaning routine (e.g., removable kettles on fryers, knobs, grease drawers on griddles, etc.)
- Installation of equipment
- Cleaning of equipment
- Seasoning of griddle plates
- Voltage conversions or gas conversions
- Pilot light adjustment
- Miscellaneous adjustments
- Thermostat calibration and bypass adjustment
- Resetting of circuit breakers, safety controls, or reset buttons
- Replacement of bulbs or fuses
- Repair of damage created during transit, delivery, or installation or created by an act of God.

#### PORTABLE EQUIPMENT

Star will not honor service bills that include travel time and mileage charges for servicing any products considered "portable" including items listed below. These products should be taken to the Service Agency for repair:

- Specialty Food Warmers
- Sandwich Grills
- Pop-Up Toasters
- Accessories of any kind (e.g. Sneeze Guards, Manual Pumps, etc.)
- Heat Lamps

The foregoing warranty is in lieu of any and all other warranties expressed or implied and constitutes the entire warranty.

Should you require any assistance regarding the operation or maintenance of any Toastmaster equipment; write, phone, fax or email our Service Department. In all correspondence mention the model number and the serial number of your unit, as well as the voltage or type of gas you are using.

Business hours: 8:00 a.m. to 4:30 p.m. Central Standard Time  
Telephone: 314-678-6303  
Fax: 314-781-2714  
Email: [customerservice@star-mfg.com](mailto:customerservice@star-mfg.com)  
Website: [www.toastmastercorp.com](http://www.toastmastercorp.com)

## **TABLE OF CONTENTS**

Warranty	i
General Information and Installation	1-2
Phase Diagram	3
Daily Operation	4
Cleaning	4
Specifications	5
Exploded Views	6-7
Parts List	8-9

## NOTES

## SAFETY SYMBOLS

These symbols are intended to alert the user to the presence of important operating and maintenance instructions in the manual accompanying the appliance.

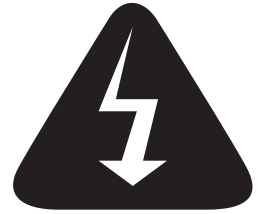

## THOROUGHLY INSPECT YOUR UNIT ON ARRIVAL



This unit has been tested for proper operation before leaving our plant to ensure delivery of your unit in perfect condition. However, there are instances in which the unit may be damaged in transit. In the event you discover any type of damage to your product upon receipt, you must immediately contact the transportation company who delivered the item to you and initiate your claim with that company. If this procedure is not followed, it may affect the warranty status of the unit. If damage or loss is not apparent until after equipment is unpacked, a request for inspection of concealed damage must be made with carrier within 15 days. Please record the model number, serial number, voltage, and purchase date in the area below at the time of receipt..

Model Number \_\_\_\_\_

Serial Number \_\_\_\_\_

Voltage \_\_\_\_\_

Purchase Date \_\_\_\_\_

## MAINTENANCE AND REPAIRS

Contact your local authorized service agent for service or required maintenance. Please have the information in the above fields ready when you call to ensure a faster service.

Using any part other than genuine Toastmaster factory supplied parts relieves the manufacturer of all liability. Due to periodic changes in designs, methods, procedures, policies, and regulations, the specifications contained in this document are subject to change without notice. Toastmaster reserves the right to change product specifications and design without notice. Such revisions do not entitle the buyer to corresponding changes, improvements, additions or replacements for previously purchased equipment. While Toastmaster exercises good faith efforts to provide information that is accurate, we are not responsible for errors or omissions in information provided or conclusions reached as a result of using the specifications. By using the information provided, the user assumes all risks in connection with such use.

PLEASE REFER TO THE WARRANTY PAGE FOR SPECIFIC WARRANTY INFORMATION.

## AUTHORIZED SERVICE AGENT LISTING

Reference the listing provided with the unit or for an updated listing go to the website or call customer service to find an agent.

Business hours: 8:00 a.m. to 4:30 p.m. Central Standard Time

Telephone: 314-678-6303

Fax: 314-781-2714

Email: [customerservice@star-mfg.com](mailto:customerservice@star-mfg.com)

Website: [www.toastmastercorp.com](http://www.toastmastercorp.com)

Please visit [www.starwebconnect.com/manuals.aspx](http://www.starwebconnect.com/manuals.aspx) for digital versions of any documents associated with this unit.



## GENERAL SAFETY INFORMATION

This equipment is designed and sold for commercial use only, and is intended for use by personnel trained and experienced in its operation. This is not sold for consumer use in and around the home nor for use directly by the general public in food service locations.

Before using your new equipment, read and understand all the instructions and labels associated with the unit prior to putting it into operation. Make sure all people associated with its use understand the units operation and safety before they use the unit.

## GENERAL INSTALLATION INFORMATION

The unit is shipped fully assembled and ready to plug into a standard outlet specified for its voltage and amp draw. If improper electrical supply can be determined through troubleshooting, contact a qualified electrician prior to using the unit. Removal or replacement of the power cord or plug will void the warranty. Should you require assistance, contact your local authorized service agent for any service or required maintenance.

Set the unit so that the rear is 0.25 inches (6 mm) higher than the front using the adjustable feet. Make certain the griddle has at least the minimum clearance on the sides and back as called out on the nameplate of the unit.

Before using the unit for the first time, ensure to clean the unit properly. Refer to the Cleaning Procedure document for cleaning instructions.

## ELECTRICAL CONNECTION

For your protection we recommend that a qualified electrician work on connecting this griddle. He should be familiar with electrical installations and all electric codes. Proper connections and power supply are essential for efficient performance. The external wiring should be in conduit or an approved type of flexible cable suitable for operation at the temperature indicated on the wiring diagram for your unit, and of a proper size to carry the load. The supply circuit should be properly fused and equipped with a means of disconnecting, as required by local electrical code. The body of the griddle should be grounded.

Before making any electrical connection to this unit, check that the power supply is adequate for the voltage, amperage, and requirements stated on the nameplate. This unit will be shipped ready to hard wire. Make certain to disconnect the unit from the power source before installing or removing any parts. Be absolutely sure that the ground connection for the receptacle is properly wired. Do not connect equipment to power without proper ground connections. Improper grounding may result in personal injury or fatality.

## WIRING

Models may be wired for operation in the field for either 1-phase or 3-phase power supplies by making line connections at the junction box located at the rear of the unit as described on the phase diagram. TMGE36 and TMGE48 models are recommended to be wired for 3-phase operation. TMGE48 models are supplied with two junction boxes and can be wire to two (2) 8 kW lines or a single 16 kW line.



CONNECT/PLUG UNIT INTO DEDICATED AC LINE WITH APPROPRIATE AMPERAGE/VOLTAGE AS SPECIFIED ON THE NAMEPLATE OF THE UNIT.



DO NOT IMMERSE OR LET THE UNIT STAND IN WATER.



DO NOT HOSE DOWN THE UNIT OR THE TABLE/COUNTER IF THE UNIT IS ON THE TABLE/COUNTER.

KEEP AWAY FROM RUNNING WATER.

**PHASE DIAGRAM**

POWER MUST BE REMOVED FROM THE UNIT BEFORE ATTEMPTING REPAIR OR SERVICE.

MAKE CERTAIN TO CHECK ALL CONNECTIONS THOROUGHLY BEFORE RESTORING POWER TO THE UNIT.

THE INFORMATION BELOW IS REFERENCED FROM DIAGRAM 2M-Z21072.

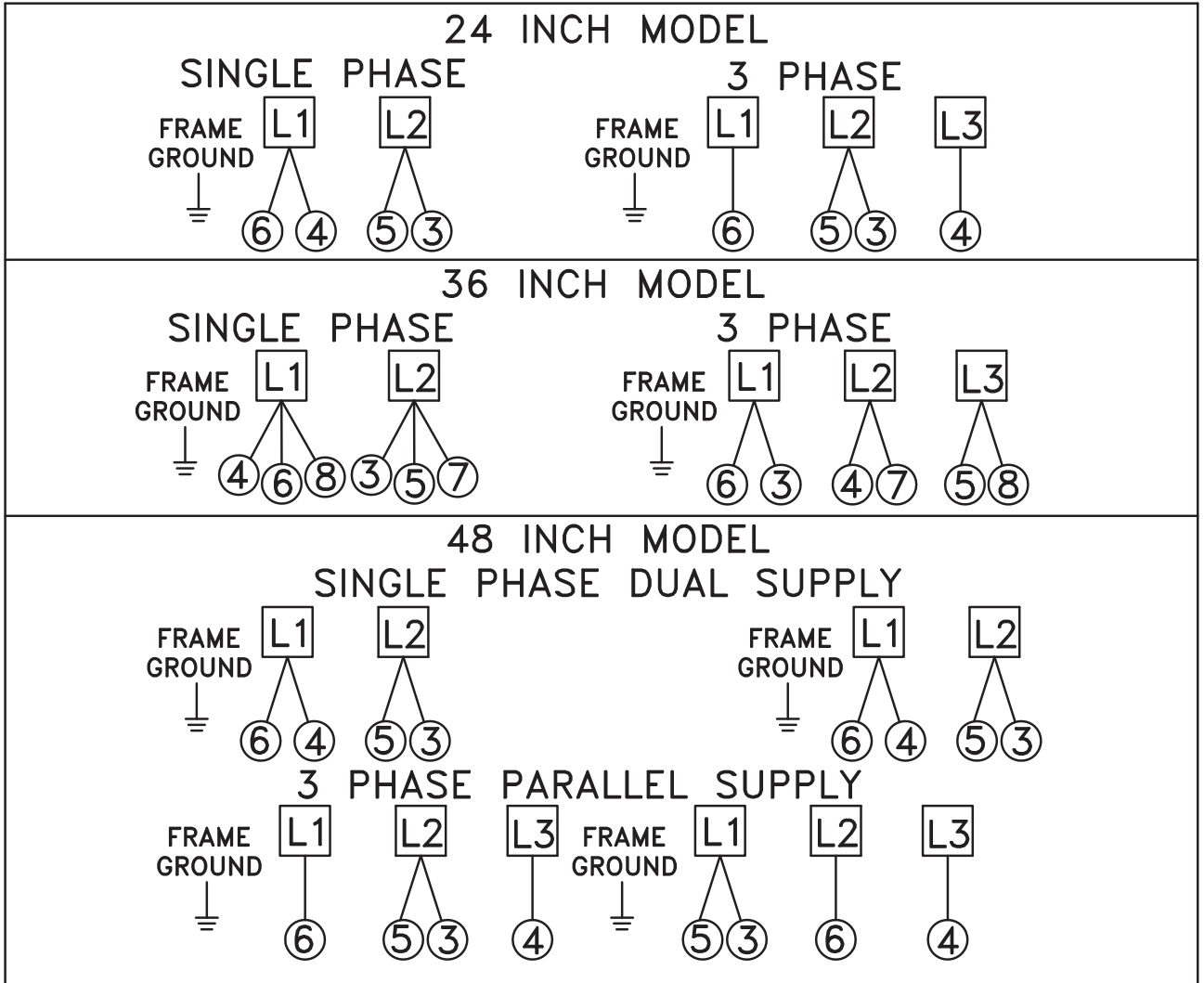

## DAILY OPERATION

### GRIDDLE CARE

It takes very little time and effort to keep the griddle attractive and performing at top efficiency. If grease is permitted to accumulate, it forms a viscous residue and then carbonizes, making it extremely difficult to remove. To prevent this condition, the following suggestions for cleanliness should be followed.

- i. After each use, scrape the griddle with a scraper or flexible spatula to remove excess grease and food and maneuver it into the grease chute. If there is an accumulation of burned on grease and/or food, the griddle should be thoroughly scoured and reseasoned. Use pumice or griddle stone while the griddle is warm. Do not use steel wool because of the danger of steel slivers getting into the food
- ii. Daily use a clean cloth and a good non-abrasive cleaner to clean the stainless steel body of the griddle is recommended. Wipe the polished front with a soft cloth so not to scratch the finish.
- iii. At least once a day, remove the grease drawer and wash it using the same process as an ordinary cooking utensil. The drawer is removed by pulling forward until it is released from its track.

### SEASONING THE GRIDDLE HEATING SURFACE

Clean the griddle surface thoroughly. After the griddle has been thoroughly cleaned, it should be seasoned to prevent food from sticking. Before using and after each thorough scouring, season the griddle heating surface in the following manner.

- i. Turn the temperature control dials to 350°F (177°C).
- ii. Using a clean cloth, not a spatula, spread a thin film of cooking oil over the griddle cooking surface. This film should remain on the hot griddle surface for half an hour.
- iii. Remove the excess oil and wipe clean.
- iv. Apply another film of cooking oil over the hot cooking area for another half hour and again remove excess oil and wipe clean. The griddle surface should now be ready for use.

### TEMPERATURE CONTROL

The temperature controls are combination “ON/OFF” switches and thermostats. Turning the dial knob automatically maintains the selected heat range. There is one thermostat for every twelve [12] inch (305 mm) wide section that operate independently.

### COOKING

Set the thermostat dial knob at the desired temperature. After a short pre-heating period, the thermostat will automatically maintain the selected temperature.

### IDLING

During idle periods, to save on operating costs, lower the temperature setting of the thermostat to about 250°F (121°C). It is not necessary to maintain cooking temperature during idle periods, as the griddle can quickly be reheated to the desired temperature.

### SIGNAL LIGHTS

Each thermostat has its own signal light which indicates when the unit's control knob is not in the off position.

### GREASE PAN

The grease pan on the front is hot and contains hot grease. Take care when removing and emptying the tray. The tray should be checked and emptied on a regular basis.

# SPECIFICATIONS

TMGE36 shown

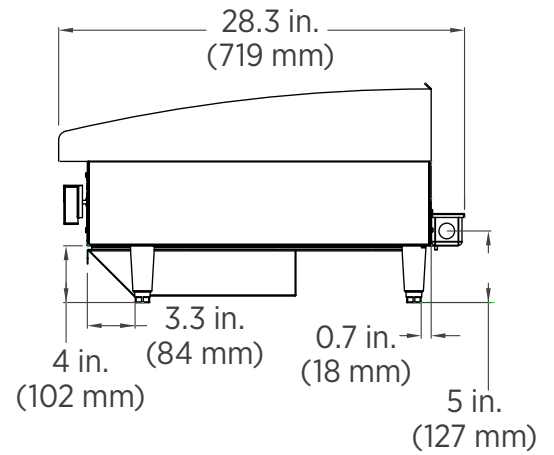
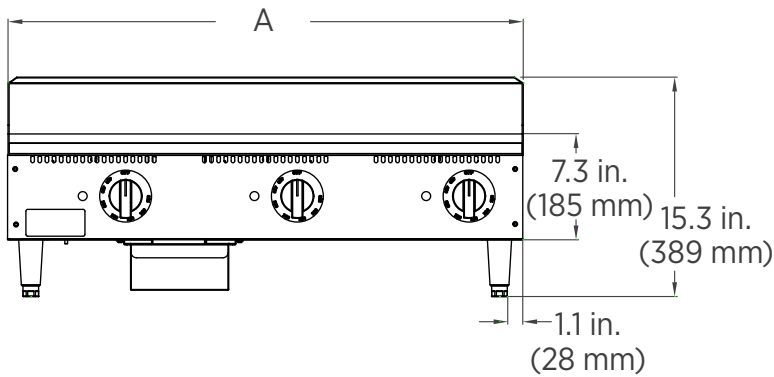
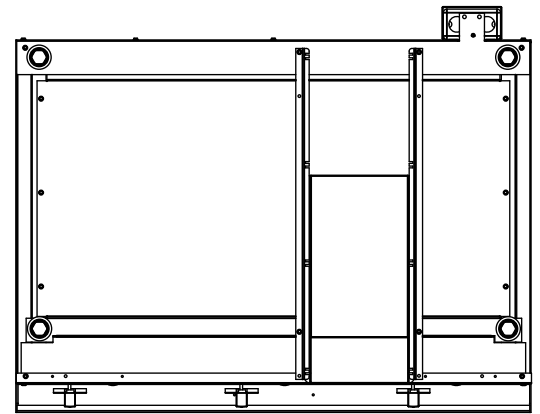
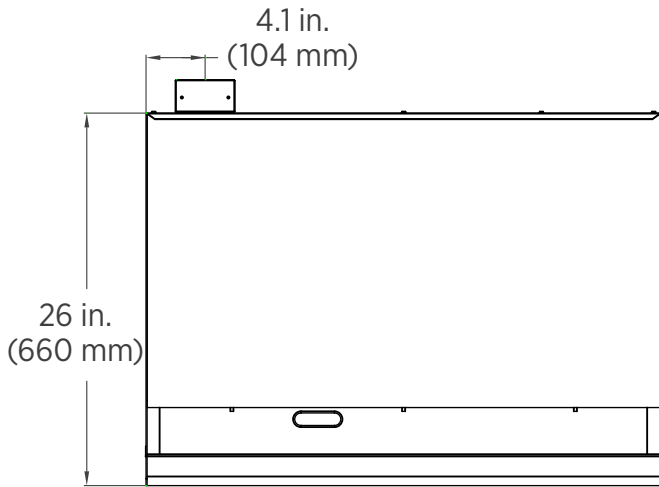

MODEL	HEIGHT	WIDTH [A]	DEPTH	APPROX. SHIP WEIGHT	APPROX. WEIGHT INSTALLED
TMGE24	15.3 in. (389 mm)	24 in. (610 mm)	28.3 in. (719 mm)	175 lb. (79.4 kg)	147 lb. (66.7 kg)
TMGE36	15.3 in. (389 mm)	36 in. (914 mm)	28.3 in. (719 mm)	262 lb. (118.8 kg)	221 lb. (100.2 kg)
TMGE48	15.3 in. (389 mm)	48 in. (1.22 m)	28.3 in. (719 mm)	350 lb. (158.8 kg)	295 lb. (133.8 kg)

MODEL	TOTAL kW	VOLTS	1Φ AMPS	3Φ AMPS L1	3Φ AMPS L2	3Φ AMPS L3
TMGE24	6/ 8	208/ 240	28.8/ 33.3	14.4/ 16.7	25/ 28.9	14.4/ 16.7
TMGE36	9/ 12	208/ 240	43.3/ 50	25/ 28.9	25/ 28.9	25/ 28.9
TMGE48	12/ 16	208/ 240	57.8/ 66.7	38.2/ 44.2	25/ 28.9	38.2/ 44.2

## FRONT-PANEL AND CONTROLS RIGHT SIDE-PANELS

TMGE36 shown

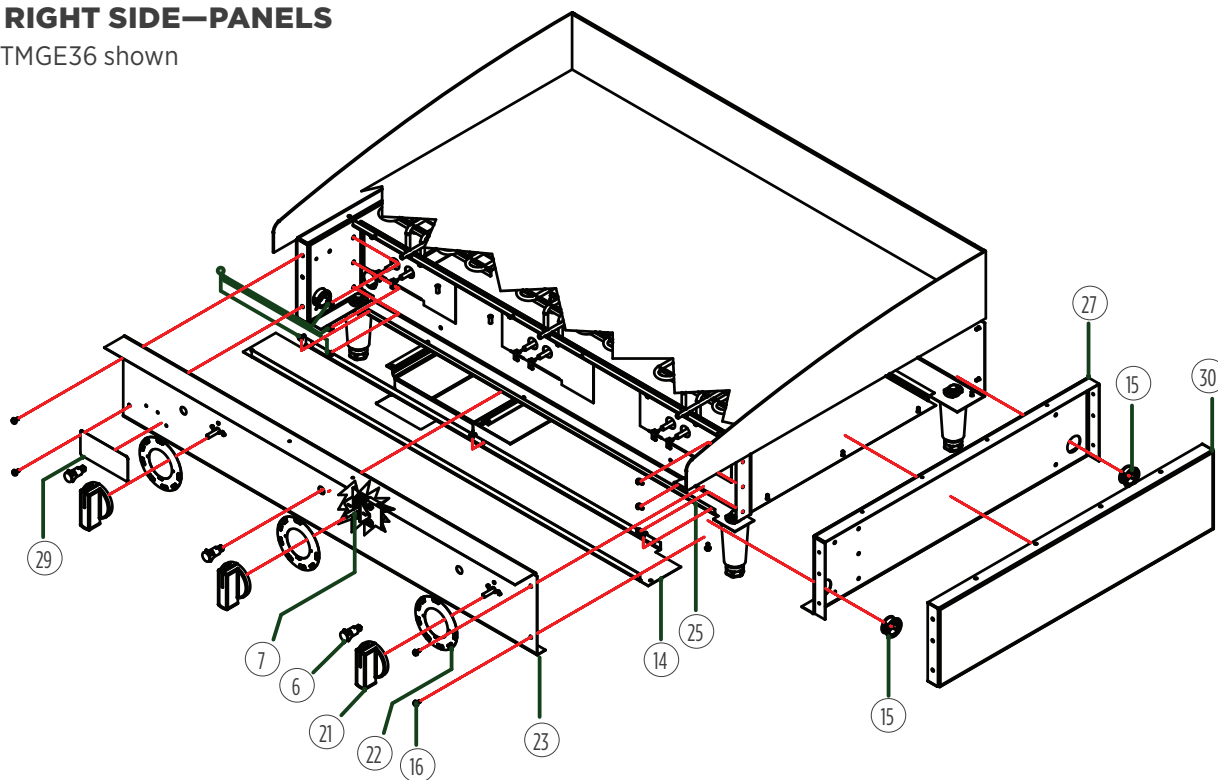

## LEFT SIDE-PANELS

TMGE36 shown

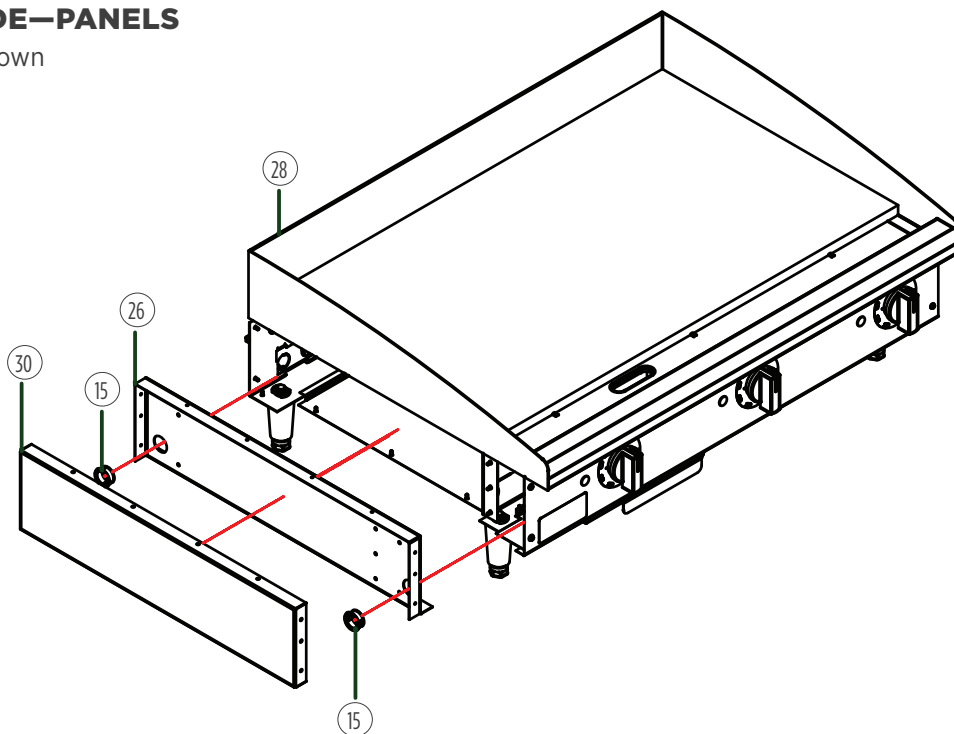

## BOTTOM

TMGE36 shown

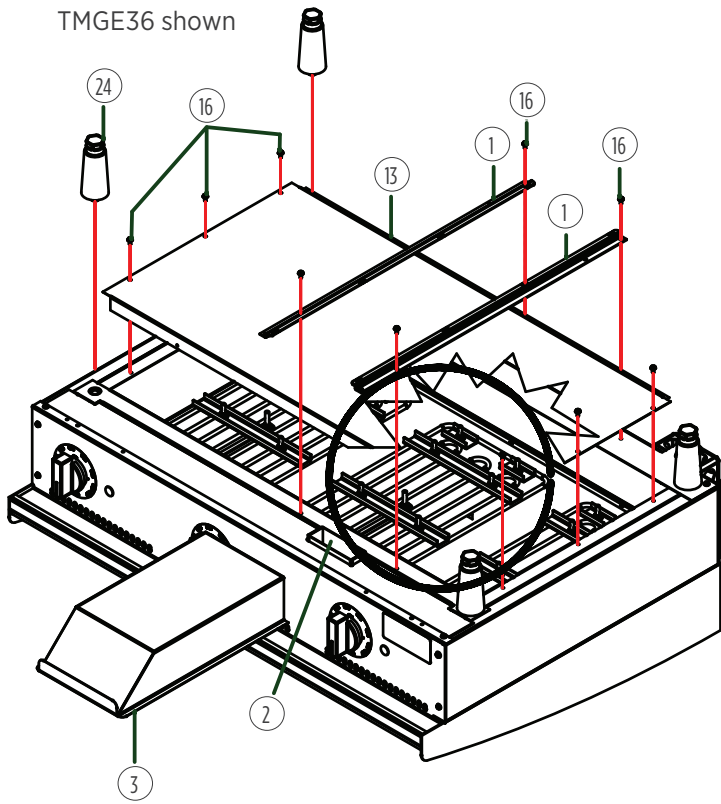

## HEATING ELEMENT

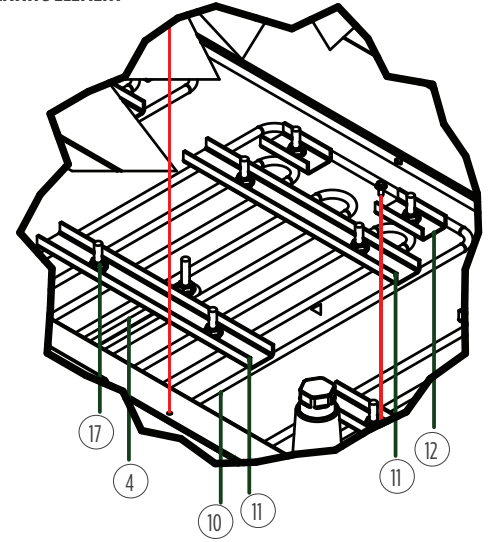

## HARDWARE

TMGE36 shown

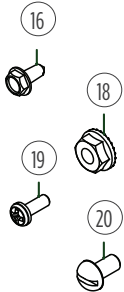

## REAR—ELECTRICAL BOX

TMGE36 shown

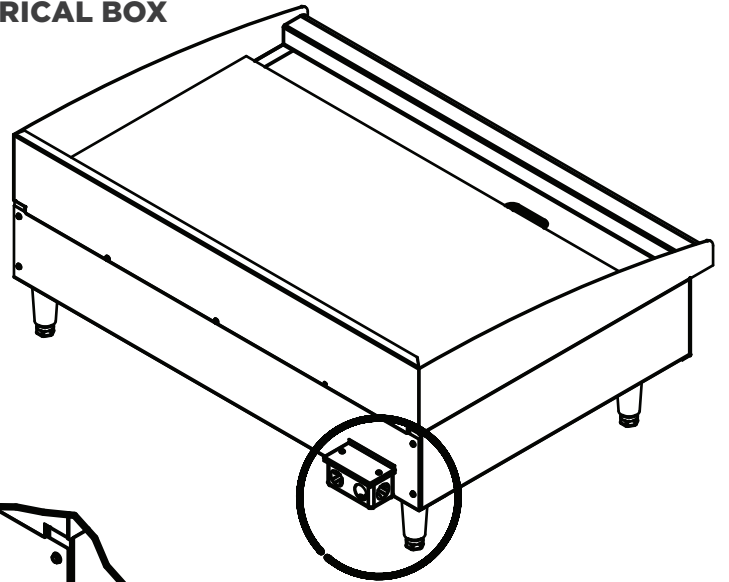

## POWER JUNCTION BOX

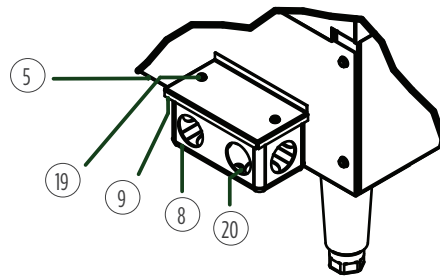

Side references are from the operator's point-of-view—from the front of the unit.  
 Items labeled "NS" are non-serviceable. Items labeled "NP" are not pictured.

REF NO	MODEL	PART NUMBER	QTY	DESCRIPTION	PAGE NO
1	ALL	G3-Z6036	2	drawer slide	7
2	ALL	G3-624304	1	grease chute	7
3	ALL	G3-Y7046	1	grease drawer	7
4	TMGE24	G3-GD0036	2	probe tube assembly	7
	TMGE36		3		
	TMGE48		4		
5	TMGE24	G3-Z5952	1	panel, rear 24-inch	7
	TMGE36	G3-Z5954	1	panel, rear 36-inch	
	TMGE48	G3-Z5956	1	panel, rear 48-inch	
6	TMGE24	2J-Y6690	2	indicator light, red	6
	TMGE36		3		
	TMGE48		4		
7	TMGE24	2T-Z5958	2	thermostat	6
	TMGE36		3		
	TMGE48		4		
8	TMGE24	2E-Y7327	1	handy box	7
	TMGE36		1		
	TMGE48		2		
9	TMGE24	G3-Y7788	1	cover, handy box	7
	TMGE36		1		
	TMGE48		2		
10	TMGE24	2N-Z5948	2	heating element	7
	TMGE36		3		
	TMGE48		4		
11	TMGE24	G3-Z5972	6	element clamp, long	7
	TMGE36		9		
	TMGE48		12		
12	TMGE24	G3-Z5973	4	element clamp, short	7
	TMGE36		6		
	TMGE48		8		
13	TMGE24	G3-Z5994	1	panel, bottom 24-inch	7
	TMGE36	G3-Z5995		panel, bottom 36-inch	
	TMGE48	G3-Z5996		panel, bottom 48-inch	
14	TMGE24	G3-Z5998	1	panel, front bottom 24-inch	6
	TMGE36	G3-Z5999		panel, front bottom 36-inch	
	TMGE36	G3-Z6001		panel, front bottom 48-inch	
15	TMGE24	2K-Z6183	3	bushing	6
	TMGE36		3		
	TMGE48		6		

REF NO	MODEL	PART NUMBER	QTY	DESCRIPTION	PAGE NO
16	TMGE24	2E-Z5970	1	wiring set, 24-inch	NP
	TMGE36	2E-Z5971	1	wiring set, 36-inch	
	TMGE48	2E-Z5970	2	wiring set, 48-inch	
17	TMGE24	2C-6517	18	1/4-20 flanged hex nut	7
	TMGE36		27		
	TMGE48		34		
18	ALL	2C-Z2893	4	#10-24 nut	7
19	TMGE24	2C-1488	2	#6-32 x 0.375-inch machine screw	7
	TMGE36		2		
	TMGE48		4		
20	TMGE24	2C-1512	2	#10-24 x 0.375-inch machine screw	7
	TMGE36		2		
	TMGE48		4		
21	TMGE24	2R-Z13016	2	knob, electric thermostat	6
	TMGE36		2		
	TMGE48		4		
22	TMGE24	2M-Z21073	2	label, toastmaster electric knob	6
	TMGE36		3		
	TMGE48		4		
23	TMGE24	G3-Z15708	1	panel, front 24-inch	6
	TMGE36	G3-Z15709		panel, front 36-inch	
	TMGE48	G3-Z15796		panel, front 48-inch	
24	ALL	2A-Z5942	4	4-inch leg	7
25	TMGE24	G3-Z5915	1	center wall assembly, 24-inch	6—NS
	TMGE36	G3-Z5925		center wall assembly, 36-inch	
	TMGE48	G3-Z5935		center wall assembly, 48-inch	
26	ALL	G3-624302	1	liner assembly, left	6
27	ALL	G3-624303	1	liner assembly, right	6
28	TMGE24	G4-TC0098	1	top weldment, 24-inch electric	6
	TMGE36	G4-TC0104		top weldment, 36-inch electric	
	TMGE48	G4-TC0107		top weldment, 48-inch electric	
29	ALL	2M-Z20970	1	toastmaster badge	6
30	ALL	G3-Z5945	2	panel, side	6
31	TMGE24	G3-Z5947	2	cover, electric	NP
	TMGE36		3		
	TMGE48		4		
32	TMGE24	2C-8833	43	#8-18 x 0.5-inch screw	NP
	TMGE36		51		
	TMGE48		56		
33	ALL	2C-Z6035	2	bolt, 1/2-13 x 3-inch	NP

