

G-SERIES

INSTALLATION & OPERATING MANUAL

PN 5-8060

G-SERIES SERVICE SINGLE DECK REFRIGERATED MERCHANDISERS

PLEASE NOTE THE FOLLOWING:

1. YOUR SPECIFIC MODEL NUMBER IS LOCATED ON THE SERIAL LABEL (USUALLY AT CASE REAR). HOWEVER, LABEL LOCATIONS MAY VARY DEPENDING UPON MODEL.
2. SEE *SERIAL LABEL LOCATION & INFORMATION* SECTION IN THIS MANUAL FOR SAMPLE LABELS.
3. CASES SHOWN IN THIS MANUAL MAY REFLECT FULL OR OPEN END PANELS / STRAIGHT OR ANGLED BASES. YOURS UNIT MAY SLIGHTLY DIFFER.
4. MODELS SHOWN ON THIS COVER SHEET DO NOT REPRESENT ALL MODELS COVERED BY THIS MANUAL.
5. SEE *MODELS LISTED IN THIS MANUAL SECTION FOR SPECIFIC MODELS TO WHICH THIS MANUAL APPLIES.*

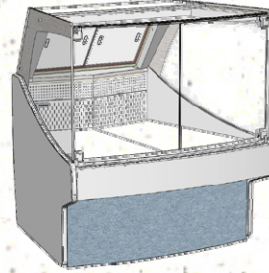

GLDSVX2R (22.5° Wedge With Vertical Hinged Glass Doors)

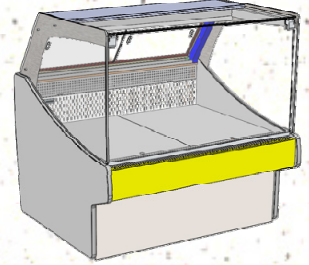

GLDSV4R (With 4' Service Vertical Glass)

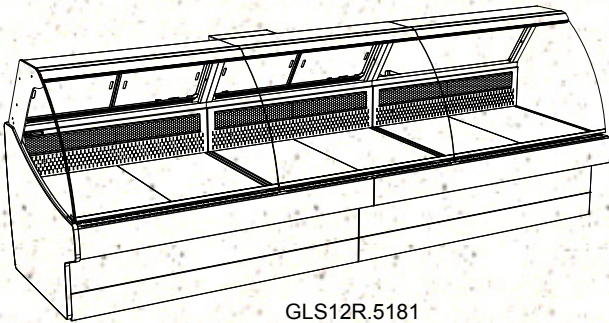

GLS12R.5181 (With Sliding Rear Doors)

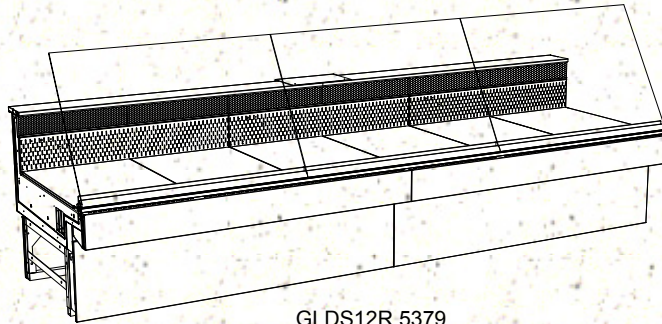

GLDS12R.5379 (Without Sliding Rear Doors or Uprights)

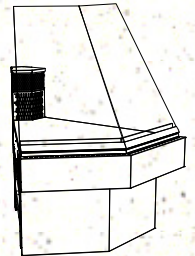

GLDSX4R.5380 (Without Rear Door or Uprights)

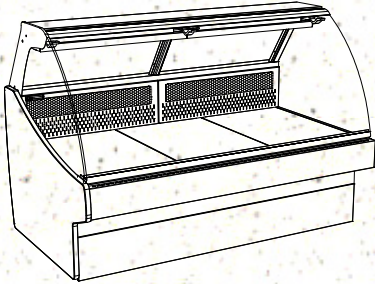

GLS6R.5002

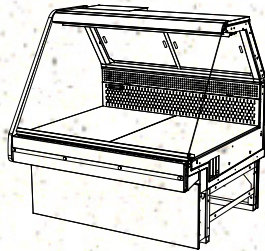

GLDS4R.5065 (With Sliding Rear Doors)

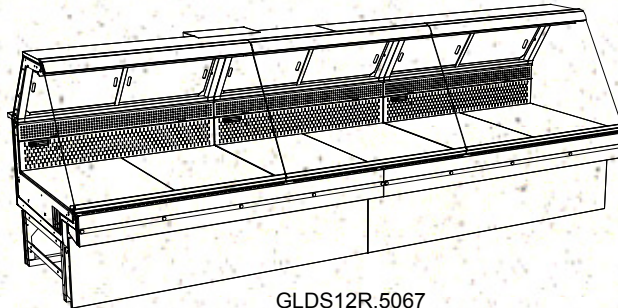

GLDS12R.5067 (With Sliding Rear Doors)

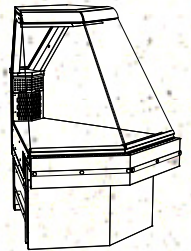

GLDSXA4R.5066 (With Rear Door and Uprights)

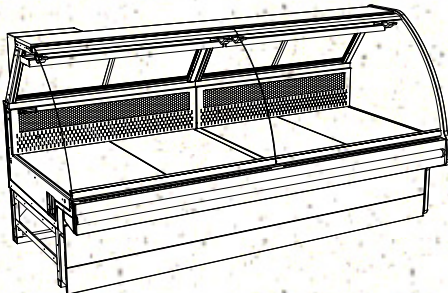

GLS8R.4937

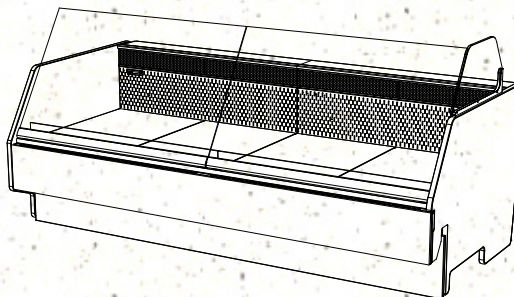

GLDSAS8RG.5718 (With Angled Front Glass)

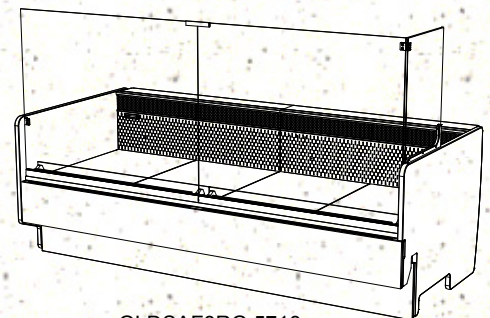

GLDSAF8RG.5718 (With Flat Front Glass)



888 E. Porter Road · Muskegon, MI 49441 Phone: 231.798.8888 Fax: 231.798.4960 www.structuralconcepts.com

TABLE OF CONTENTS

OVERVIEW / TYPE / COMPLIANCE / WARNINGS / PRECAUTIONS / WIRING / PLUGS	3-4
DETERMINING YOUR MODEL AND ITS CASE DIMENSIONS / MODELS TO WHICH THIS OPERATING MANUAL APPLIES	5
INSTALLATION: SKID REMOVAL / POSITIONING UNITS / ADJUSTING LEVELERS	6
FRAME SUPPORT RAIL SHIMMING	7
CASE-TO-CASE ROUTE FOR REFRIGERATION / ELECTRICAL LINES (NOT ON ALL CASES)	8
REMOVABLE REAR SLIDING DOOR FRAME ASSEMBLY	9
CASE ADJOINMENT: DISSASSEMBLY / SEALING UNITS TOGETHER	10
CASE ADJOINMENT: SCREW PLACEMENT / WIRING COVER / REAR DOOR REPLACEMENT ...	11
FIELD WIRING	12
START-UP AND OPERATION	13-15
INSTALLATION: FRONT GLASS ALIGNMENT & ADJUSTMENT (VIA RAIL SYSTEM)	16
MAINTENANCE FUNDAMENTALS	17-19
DIPWELL™ OPERATION AND REMOVAL FOR CLEANING	20
DIGITAL THERMOMETER / CAREL® TEMPERATURE CONTROLLER LOCATION & ACCESS	21
DRAIN / SHUT-OFF VALVE / BALANCE VALVE LOCATION & ACCESS	22
METAL AIR DIFFUSER PLATE / REMOVAL / REPLACEMENT (FOR CERTAIN CASES)	23
HONEYCOMB AIR DIFFUSER REMOVAL/REPLACEMENT (FOR CERTAIN CURVED CASES)	24
HONEYCOMB AIR DIFFUSER REMOVAL/ REPLACEMENT (FOR CERTAIN CASES)	25
CURVED GLASS ADJUSTMENT PROCEDURE	26
SERIAL LABEL INFORMATION & LOCATION	27
CLEANING SCHEDULE TO BE PERFORMED BY STORE PERSONNEL	28
CLEANING PROCEDURE - CAMBRIA® NATURAL QUARTZ SURFACE	29
CLEANING & MAINTENANCE of SILESTONE® NATURAL QUARTZ SURFACE	30
TROUBLESHOOTING	31-32
PREVENTIVE MAINTENANCE (TO BE PERFORMED BY TRAINED SERVICE PROVIDER)	33-34
CAREL® TEMPERATURE CONTROLLER INFORMATION (PRIMARILY FOUND ON SELF-CONTAINED UNITS ONLY)	35-37
SCC TECHNICAL SERVICE CONTACT INFORMATION & WARRANTY INFORMATION	38

OVERVIEW

- These Structural Concepts G-Series® Service Single Deck Refrigerated Cases are designed to merchandise products at 41 °F (5 °C) or less product temperatures.
- Products must be pre-chilled at 41°F (3 °C) or less prior to being placed in merchandiser.
- Cases should be installed and operated according to this operating manual's instructions to ensure proper performance. Improper use will void warranty.

TYPE

This unit is designed for the display of products in ambient store conditions where temperatures and humidity are maintained within a specific range.

- For Type 1 Conditions (most cases): ambient conditions are to be at 55% maximum humidity and maximum temperatures of 75 °F (24 °C).
- For Type 2 Conditions: ambient conditions are to be at 60% maximum humidity and maximum temperatures of 80 °F (27 °C).

- If unsure if unit is designed for Type 1 or Type 2 conditions, see label on case. Note: Label locations vary depending upon model.

COMPLIANCE

- Performance issues when in violation of applicable NEC, federal, state and local electrical and plumbing codes are not covered by warranty.
- See below compliance guideline.

WARNINGS

- This page contains important warnings to prevent injury or death.
- Please read carefully!

PRECAUTIONS and WIRING DIAGRAMS

- See next page for **PRECAUTIONS** and **WIRING DIAGRAM** information.



**ATTENTION
INSTALLER**

COMPLIANCE
This equipment **MUST** be installed in compliance with all applicable NEC, federal, state and local electrical and plumbing codes.

WARNING

**ELECTRICAL
HAZARD**



WARNING
Risk of electric shock. Disconnect power before servicing unit. **CAUTION!** More than one source of electrical supply is employed with units that have separate circuits. *Disconnect ALL ELECTRICAL SOURCES before servicing.*

WARNING

**KEEP
HANDS
CLEAR**



WARNING
Hazardous moving parts. Do not operate unit with covers removed. Fan blades may be exposed when deck panel is removed. Disconnect power before removing deck panel.

WARNING

**HOT
SURFACE**



WARNING
Condensate pan is hot! Disconnect and allow to cool before cleaning or removing from case.

PRECAUTIONS

- Following are important precautions to prevent damage to unit or merchandise.
- Please read carefully!
- See previous page for specifics on **OVERVIEW**, **TYPE**, **COMPLIANCE** and **WARNINGS**.

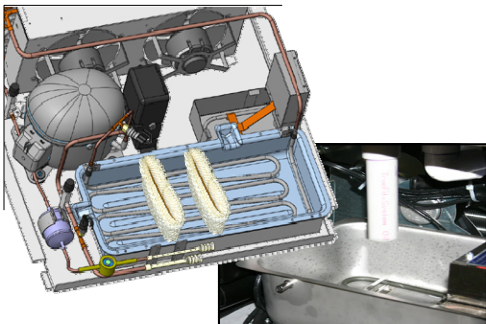
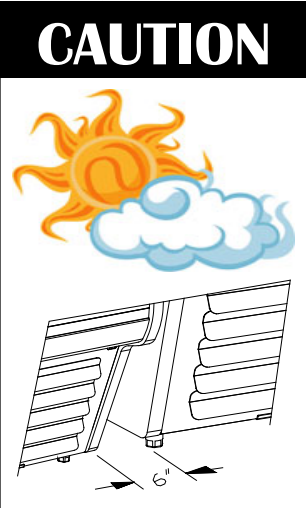
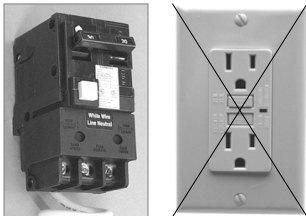

WIRING DIAGRAM

- Each case has its own wiring diagram folded and in its own packet.
- Wiring diagram placement may vary; it may be placed near ballast box, field wiring box, raceway cover, or other related location.

CAUTION
Fluorescent lamps have been treated to resist breakage and must be replaced with similarly treated lamps.

CAUTION! GFCI BREAKER USE REQUIREMENT
If N.E.C. (National Electric Code) or your local code requires GFCI (Ground Fault Circuit Interrupter) protection, you **MUST** use a GFCI breaker in lieu of a GFCI receptacle.

CAUTION! POWER CORD AND PLUG MAINTENANCE
Risk of electric shock. If cord or plug becomes damaged, replace only with cord and plug of same type.

CAUTION! ADVERSE CONDITIONS / SPACING ISSUES

- Performance issues caused by adverse conditions are **NOT** covered by warranty.
- End panels must be tightly joined or kept at least 6-inches away from any structure to prevent condensation.
- Unit must be kept at least 15-feet from exterior doors, overhead HVAC vents or any air curtain disruption to maintain proper temperatures.
- Unit must not be exposed to direct sunlight or any heat source (ovens, fryers, etc.).
- Tile floors, low ceilings or small rooms will increase noise level. Whisper Cool compressor blanket or remote unit may resolve noise level issues.
- Keep at least 8-inch clearance above unit for air discharge (self-contained units only).

CAUTION! CHECK CONDENSATE PAN POSITION & PLUG
Water on flooring can cause extensive damage!
Before powering up unit, check and confirm that:

- Condensate pan is **DIRECTLY UNDER** condensate drain.
- Condensate pan plug is securely plugged into receptacle.
- Overflow pan has plug connected to its box. Units with optional Clean Sweep™ **MUST HAVE 2** plugs connected.

DETERMINING YOUR MODEL AND ITS CASE DIMENSIONS:

Note 1. Your model number can be found on serial label (usually at case rear). However, serial label placement can sometimes vary depending upon model. See *SERIAL LABEL INFORMATION & LOCATION* section in this manual for serial label samples.

Note 2. Dimensions of most models can be found at www.structuralconcepts.com. Simply enter the case model number into the Product Number Search box. Click the ***product specification*** link for complete dimensions.

Note 3. If your specific model is not found, contact technical service (phone number is listed at Technical Service section in this manual) for dimensions.

Note 4. CDRs (Customer Design Requests) are listed with a 4-digit suffix. Dimensions are very similar to standard model (pre-suffix) dimensions.

MODELS TO WHICH THIS OPERATING MANUAL APPLIES:

Model Applicability Note: *This Operating Manual Encompasses The Following Standard G-Series Models: GLDS3R.5549 GLDS3RG.5654 GLDS4R GLDSV4R GLDS4R.5065 GLS4R.5135 GLDS6R GLDS5R GLS6R.5002 GLDS8R GLS8R.4937 GLS8R.5133 GLS8R.5134 GLDS8R.5549D GLDS10R GLDS10R.5549E GLDS12R GLDS12R.5067 GLS12R.5181 GLDS12R.5379 GLDSVX2R GLDSXA3R GLDSXA3R.5545A GLDSXA4R.5066 GLDSXA4R.5576B GLDSX4R.5380 GLDSA8R.5718 GLDSAS8RG.5718 GLDSFS8RG.5718 GLDSXA9R.5576C GLDSV4R GLDSVX2R (Doc Option #20-09312)*

INSTALLATION: SKID REMOVAL / POSITIONING UNITS / ADJUSTING LEVELERS

Note: Units shown may not depict an exact representation of your particular unit being installed.

1. Remove Unit From Skid

- Caution: Case must always remain supported or center of gravity will allow case to fall.
- Slide unit to rear of skid. Tip backward off skid.

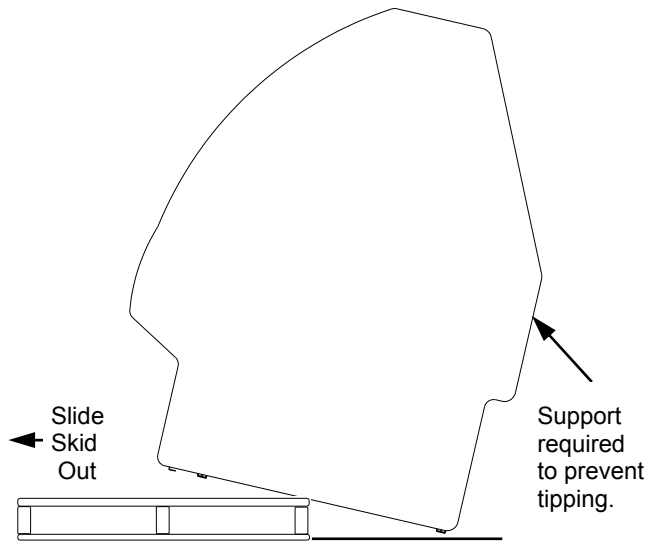

2. Position & Align Case Alongside Other Cases

- Before adjusting levelers (or shimming frame support rails), check that case is properly positioned and, if required, aligned with adjoining cases.
- This may require the repositioning of the case you

are installing or the already positioned case.

- Align multiple units carefully in areas A and B (as shown at right).

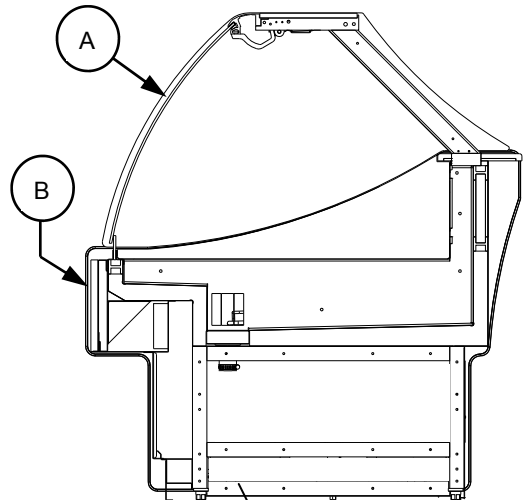

3. Adjust Levelers

- Certain cases (usually self-contained units) use levelers instead of rails.
- If your case uses rails, see **FRAME SUPPORT RAIL SHIMMING** section in this manual (next page) for adjustment instructions.
- If your case uses levelers, you may need to remove front or rear toe-kick to access them.
- Use adjustable wrench to adjust leveler.
- Depending upon case weight it may be necessary to use a pry bar to accomplish this task.
- Do not use pry bar on toe-kick as it may buckle.
- Do not use pry bar on end panel as it may chip.
- Use pry bar **ONLY** on base frame to avoid damaging case.
- See illustration and photos at right.

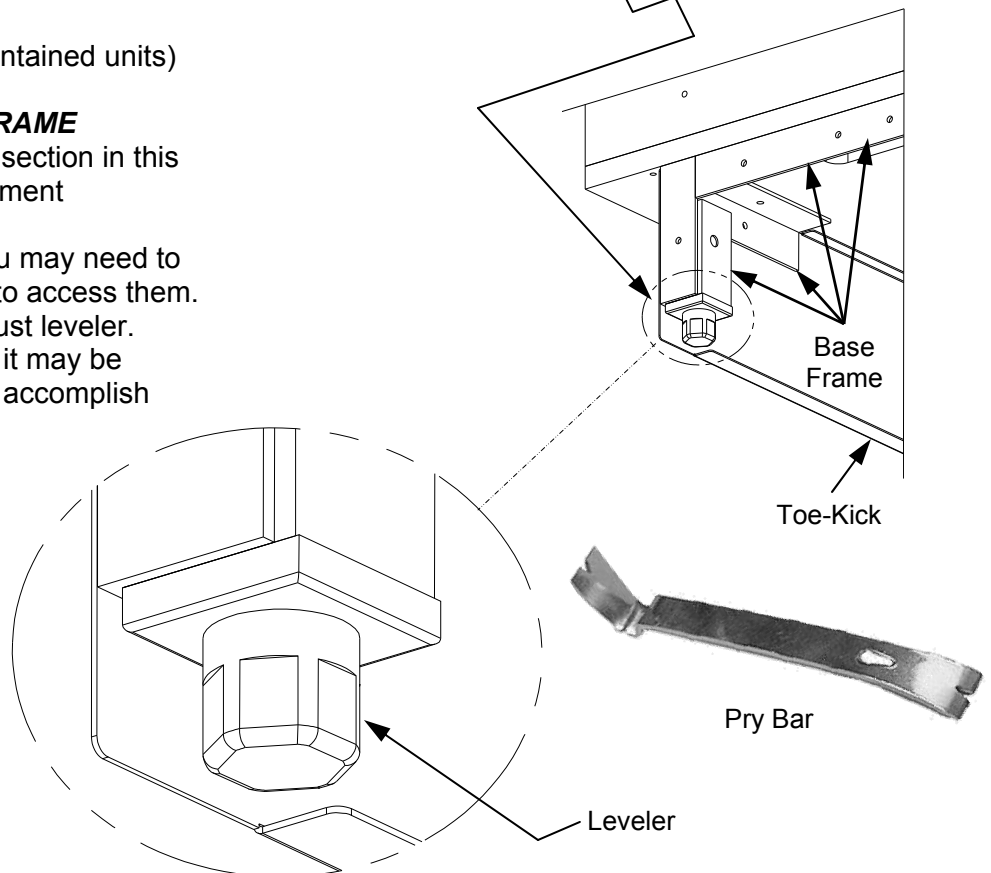

FRAME SUPPORT RAIL SHIMMING

Note: Units shown may not depict an exact representation of your particular unit being installed.

Frame Support Rails Must Be Shimmed

- Illustration below shows case with frame support rails.
- Shims will be provided with all cases that have frame support rails.
- Use shims to level case.
- **Note:** After case is in position, it must be sealed to floor to prevent entry or leakage of liquid or moisture.

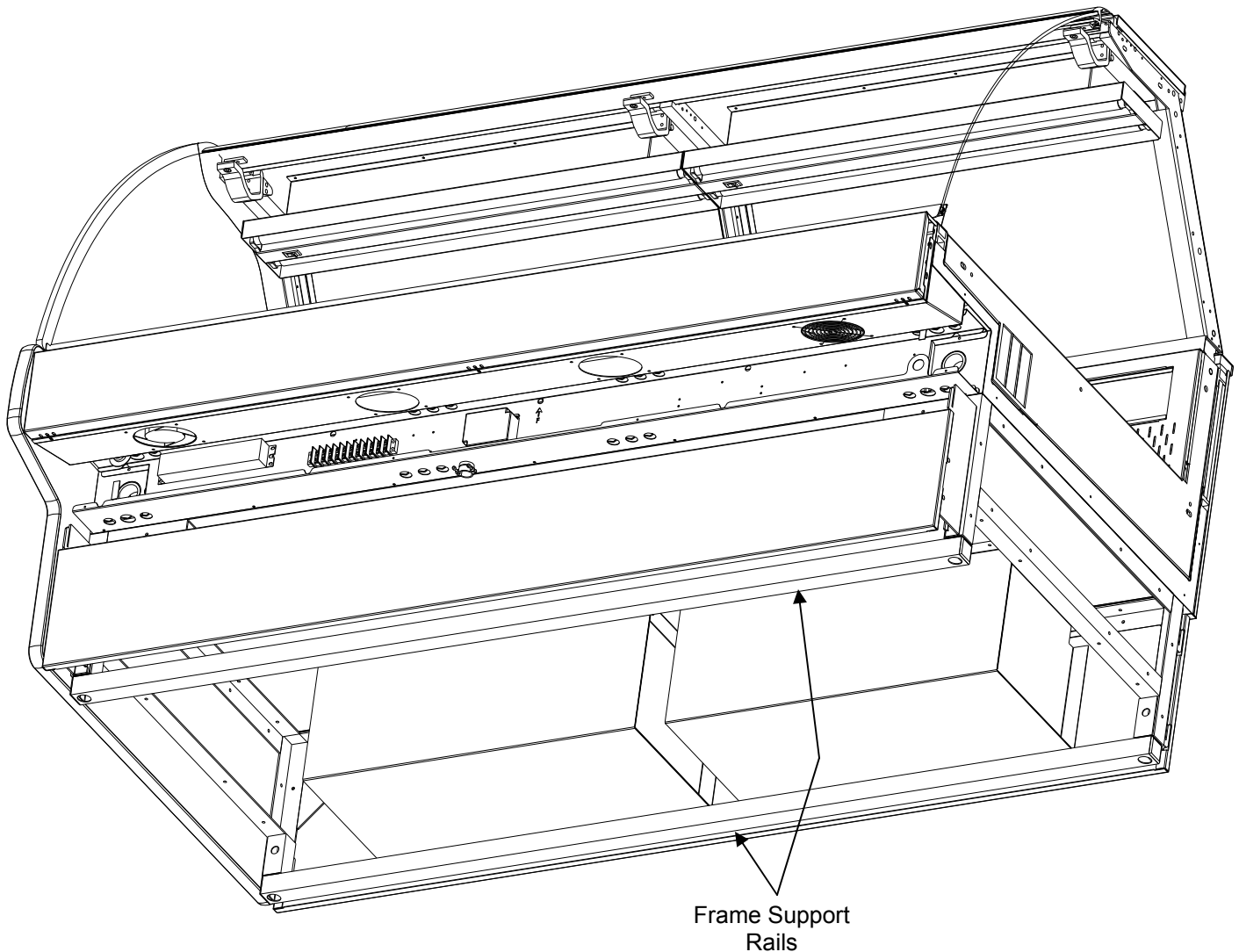

Case Is Partially Disassembled For Illustrative Purposes Only

CASE-TO-CASE ROUTE FOR REFRIGERATION / ELECTRICAL LINES (NOT ON ALL CASES)

Note: Units shown may not depict an exact representation of your particular unit being installed.

Openings In End Panels For Refrigeration/Electrical Lines To Run Case-To-Case

- Illustration below shows model GLDSA8R.5718. Note the openings in end panels for refrigeration lines and electrical lines to be routed from case to case.
- This feature is not on all cases.

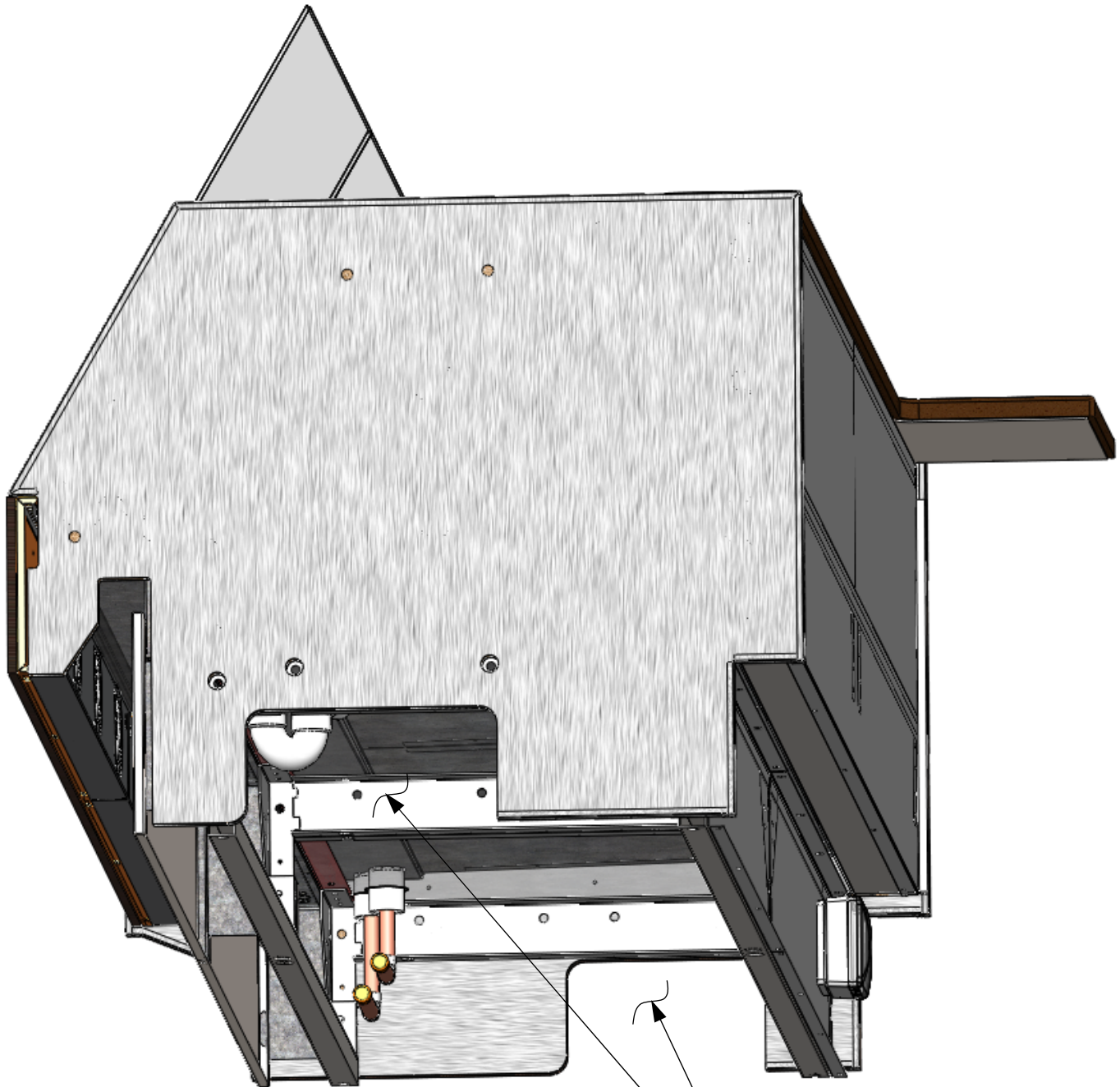

Model GLDSA8R.5718 Shown
(Your Case May Vary)

Openings in End Panels For
Refrigeration Lines and Electrical
Lines Route Through

REMOVABLE REAR SLIDING DOOR FRAME ASSEMBLY

Removable Rear Sliding Door Frame Assembly

1. View of removable rear sliding doors intact.
2. View of door frame assembly "saddle". Each side of door frame assembly rests on the "door frame saddle" (attached to uprights) while in case.
3. View of entire rear sliding door frame assembly being rotated to vertical position (ready to lift out).
4. View of rear sliding door frame assembly resting on frame retaining hooks.
5. Enlarged view of door frame resting on frame retaining hook.
 - Note: Acrylic sliding doors can be entirely removed from frame for cleaning.

Caution! If removing rear sliding door frame from case (for cleaning or maintenance) place frame in a low-traffic, safe area to avoid damage to unit.

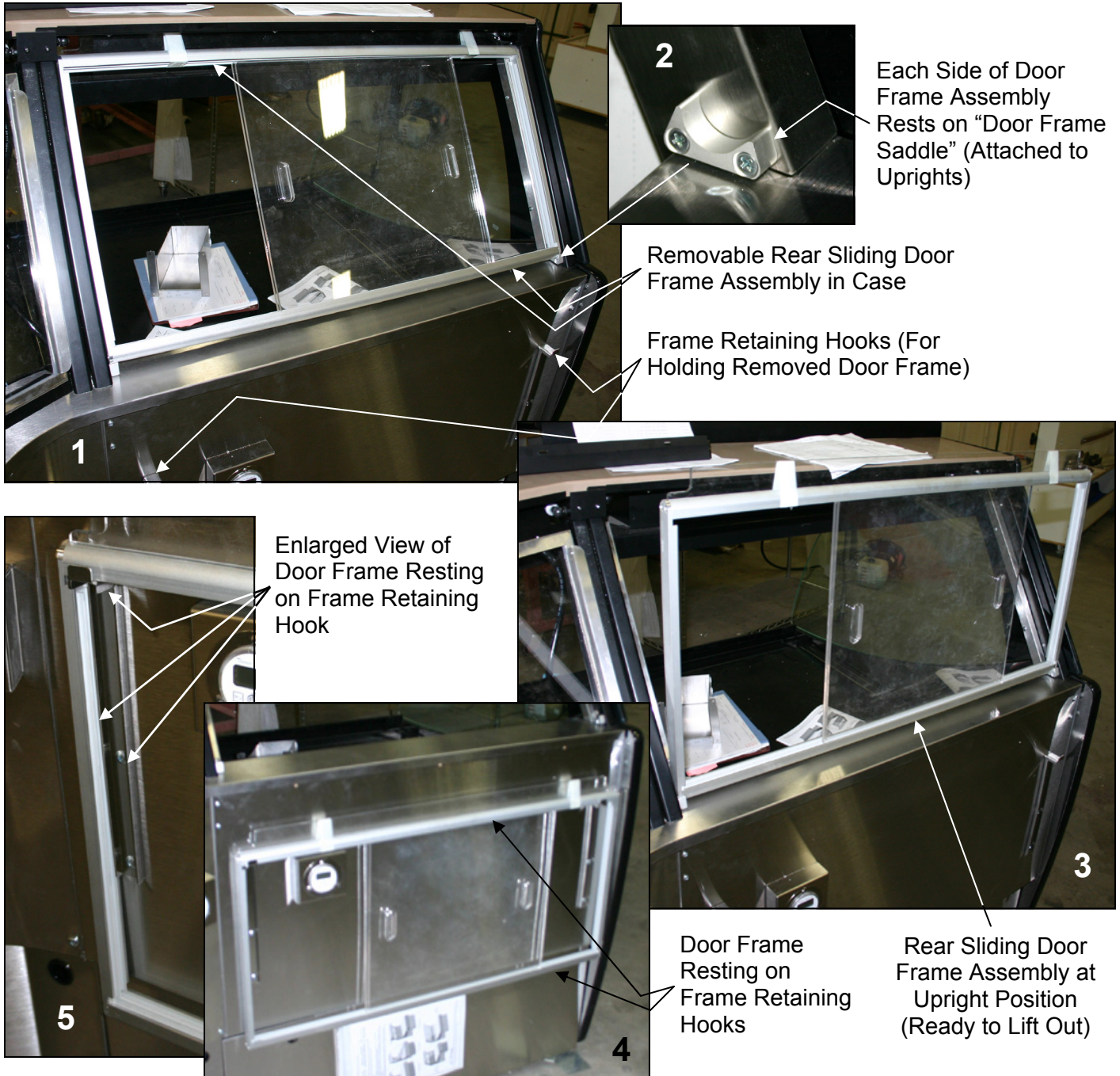

CASE ADJOINMENT: DISSASSEMBLY / SEALING UNITS TOGETHER

1. Rear Sliding Door / Wire Cover Removal

- You must remove rear sliding doors to access areas in uprights to adjoin cases.
- You must **also** remove wiring cover to access areas in uprights to adjoin cases.
- Photo at right shows wiring cover to remove.

2. Sealing Units Together

- Follow these steps to assure a secure, lineup.
- Line up adjoining case (same model) bolt-hole to bolt-hole to this case.
- Level units from highest point of floor.
- Either adjust levelers or shim the frame support rails (depending upon construction of case).
- Front of cases **MUST** be flush with each other. After case is level, they are to be same height.
- After the 'first' case is level, apply industrial grade butyl caulk on **non-visible areas**. You may use industrial grade silicone sealant on **visible areas**.
- Form Two (2) Caulk/Sealant Lines: (Sanitation and Refrigeration). See illustration below-right for outline of caulk/sealant lines.
- If supplied both butyl and silicone, use butyl on non-visible areas and silicone on visible areas. Otherwise, urethane is acceptable for all areas.
- See next page for instructions on screw placement, wiring cover reattachment and rear door replacement.



Wire Cover

Retaining Screws

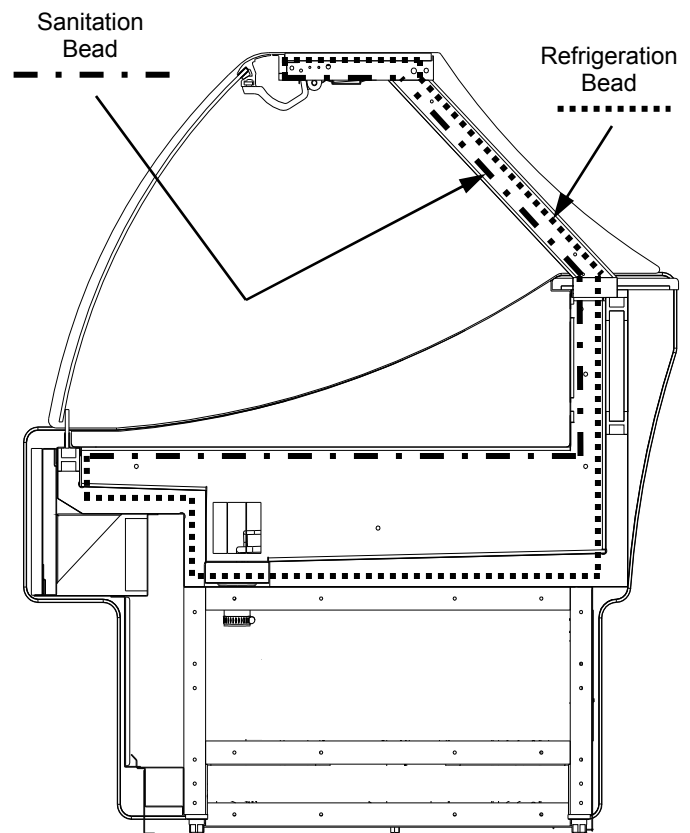

Note: If supplied, butyl is to be used on non-visible areas.

Silicone is to be used on all visible areas.

Urethane is acceptable for all areas.



CASE ADJOINMENT: SCREW PLACEMENT / WIRING COVER / REAR DOOR REPLACEMENT

1. Case Adjoinment: Screw Placement

- A. Note: Illustration at right and photo below is partially disassembled for illustrative purposes only.
- B. Screws to adjoin units are SCC-supplied.
- C. After cases are properly leveled (or shimmed) and sealant applied, units are to be adjoined with screws at the five (5) locations shown in illustration (at right) and photo (below).
- D. Using SCC-supplied nuts & bolts, **lightly tighten** each of the bolts in a cross-wise pattern. Work your way around the pattern, tightening more firmly at each pass. Do not completely tighten one bolt and then start on next!
- E. As cases are being bolted together, check that case is still level. Adjust levelers (or shim) accordingly. Repeat this process for each adjoining case.

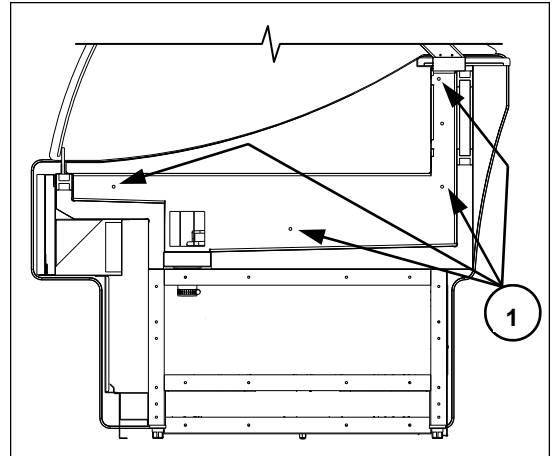

2. Wiring Cover and Rear Door Replacement

- Reattach wiring cover and replace rear doors when done.



FIELD WIRING

Note: Units shown may not depict an exact representation of your particular unit being installed.

Electrical Connections

- Field wiring hook-up / electrical access locations are shown in illustrations below (may not exactly reflect your particular unit).
- Single phase leads are provided.

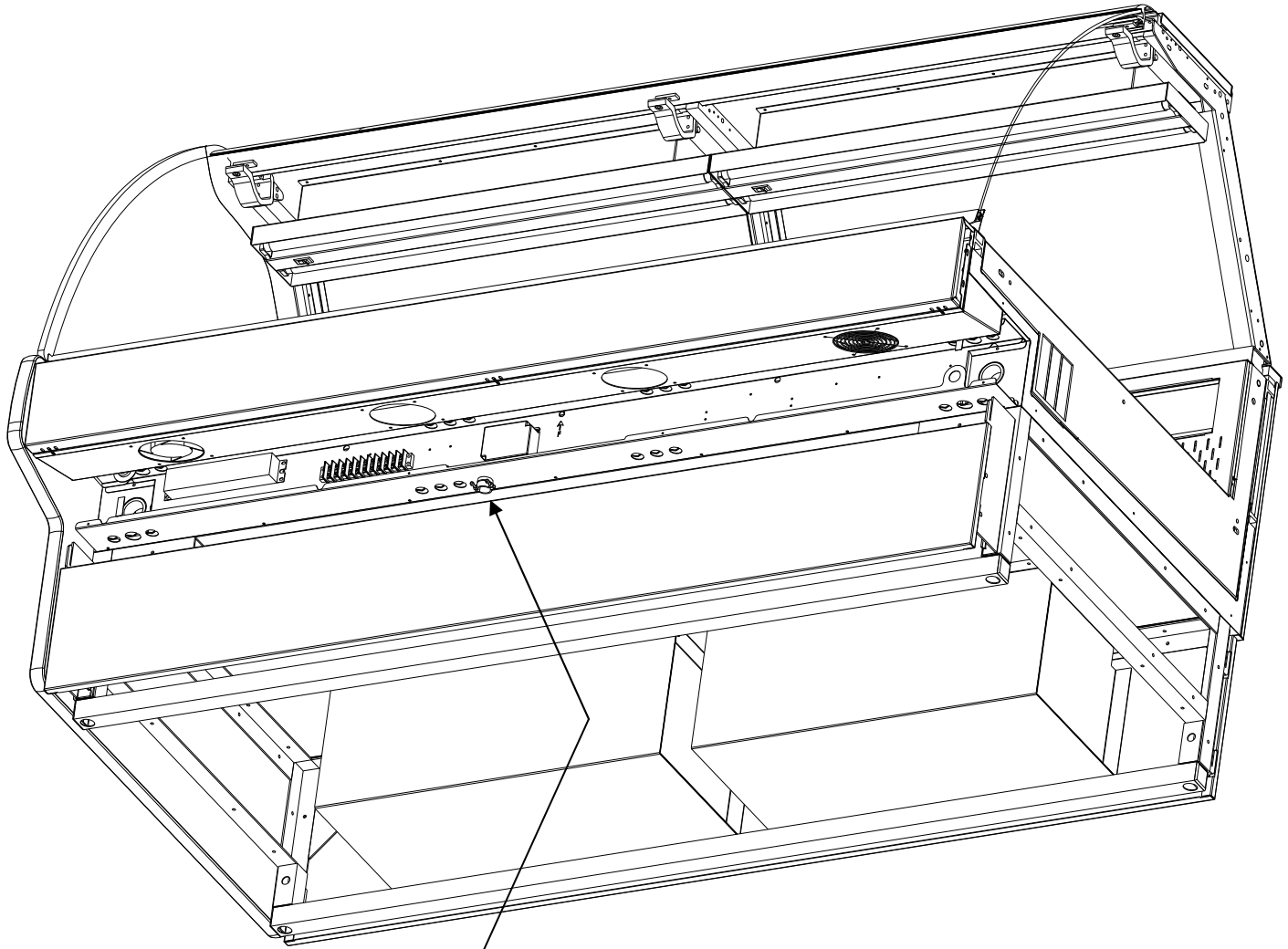

Field Wiring
Hookup (for
Remote Cases)

START-UP AND OPERATION: START-UP / LOWER FRONT PANEL & TOE-KICK REMOVAL

1. Merchandiser Start-Up

- **Remote Units:** Case is hard-wired. When power is supplied, case will power-up.

Note 1: Illustrations shown is with end panel (and lower front panel/toe-kicks) removed for illustrative purposes only.

Note 2: Illustrations shown may not exactly reflect your particular model, features or options.

Note 3: See next page for instructions on lights and optional rear door removal.

2. Lower Front Panel/Toe-Kick Removal

- Lower front panel/toe-kick may be removed by simply lifting upward and away from case.
- No tools are needed to do so.
- See illustrations below.
- Rear panels are removable in same manner.

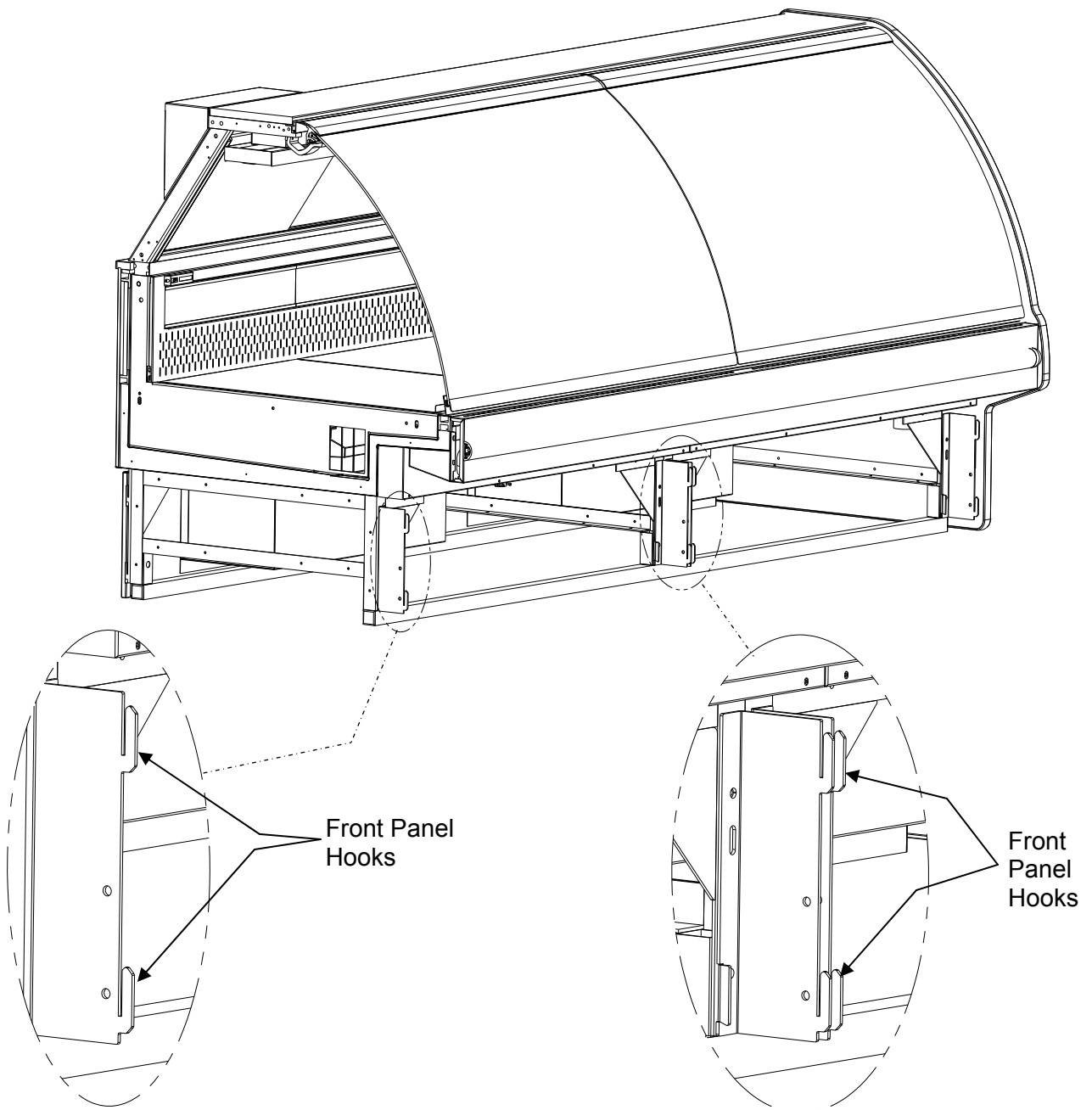

3. Lights and Doors

- Turn on the lights. Whether remote or self-contained, light switch is located on inside of case at top right, from case rear.
- See illustration at top right.

4. Removing Rear Doors (Optional)

- See illustration below left.
- Move rear doors toward the center of case.
- Individually lift each door up toward the top of case and pivot bottom of the door out.
- **Caution:** Gently set doors down to avoid marring, scraping, scratching or breakage.

Note: Illustrations shown may not exactly reflect your particular model, features or options.

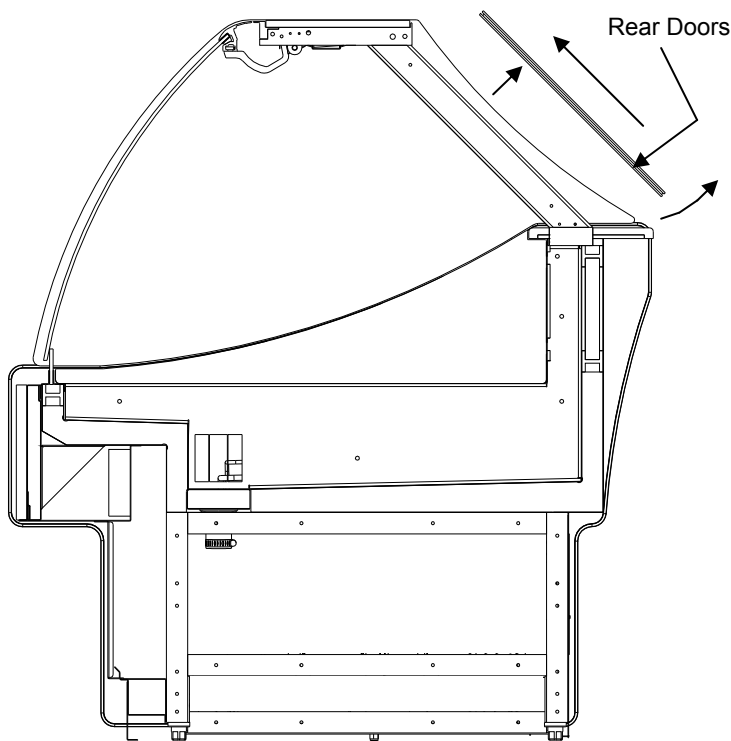
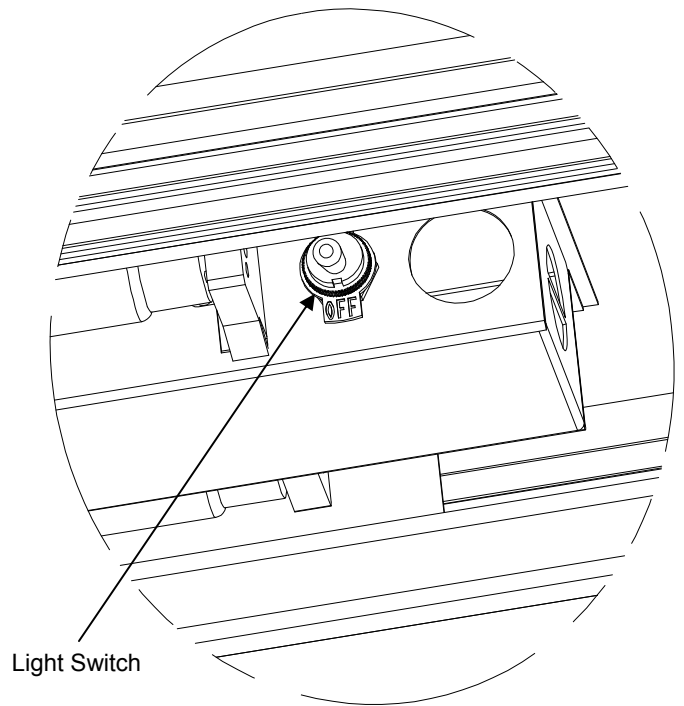

View of Rear Doors being lifted up, pivoted out and away from case.

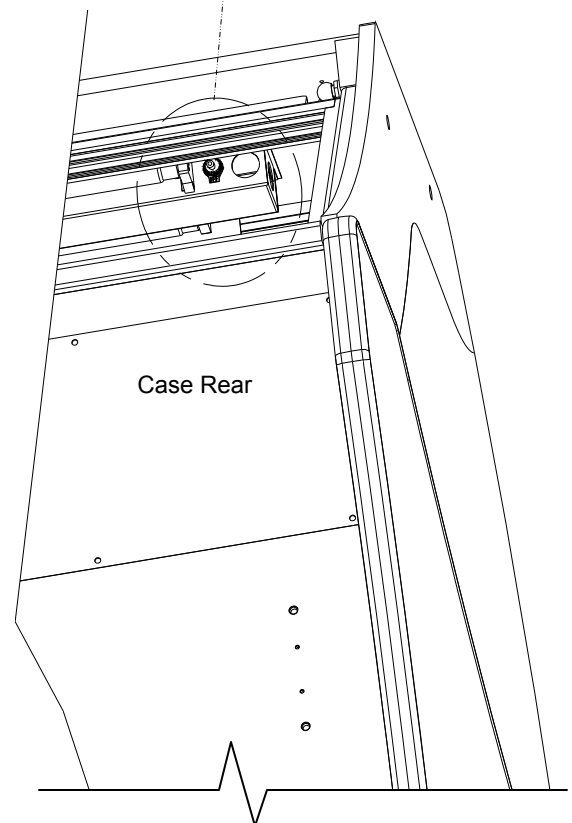

5. Adjustable Front Glass (For Cleaning, Etc.)

- Front glass can be raised and lowered to allow more thorough cleaning.
- Certain glass hinges are at the lower part of the case (as shown immediately below).
- Other glass hinges are at the upper part of the case (as shown at bottom of this page).
- See **CLEANING SCHEDULE (TO BE PERFORMED BY STORE PERSONNEL)** section in this manual for cleaning instructions.
- Grasp the top (or bottom) of the glass and slowly lower (or raise).
- After cleaning, be sure to return front glass to its original position.
- **Note: Illustrations shown may not reflect your particular model, features or options.**

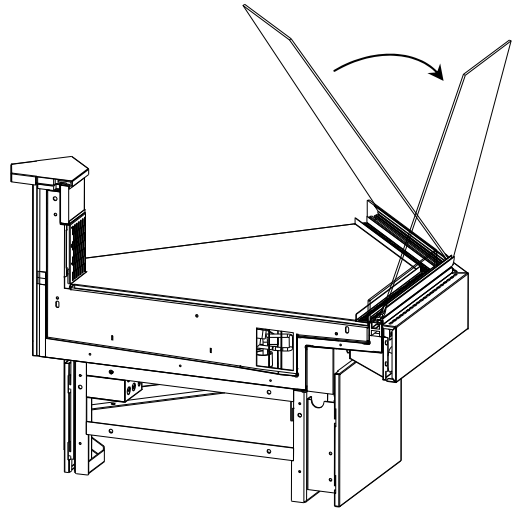

Model GLDSX4R.5380 Shown Above

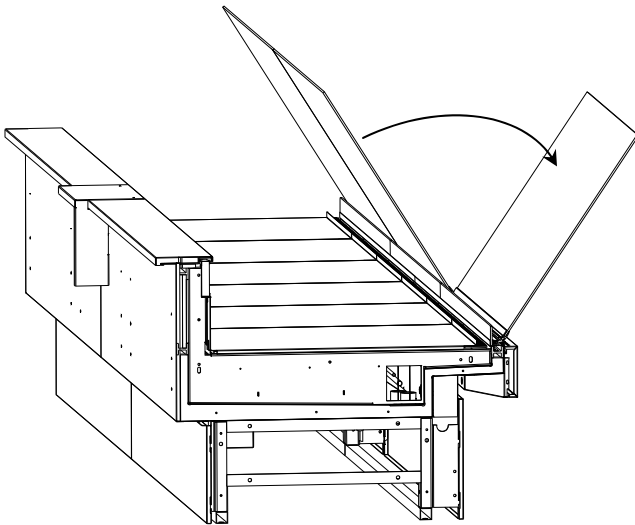

Model GLDS12R.5379 Shown Above

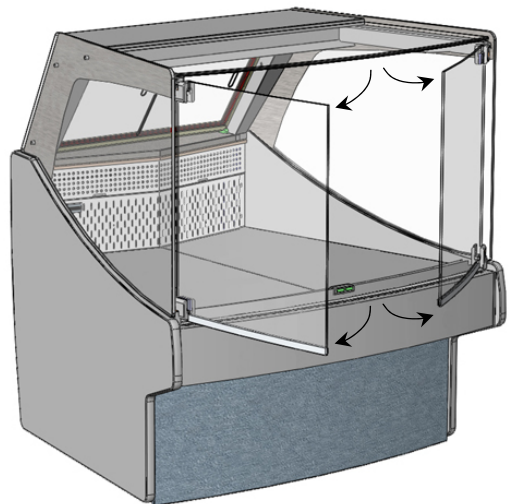

Model GLDSVX2R Shown Above

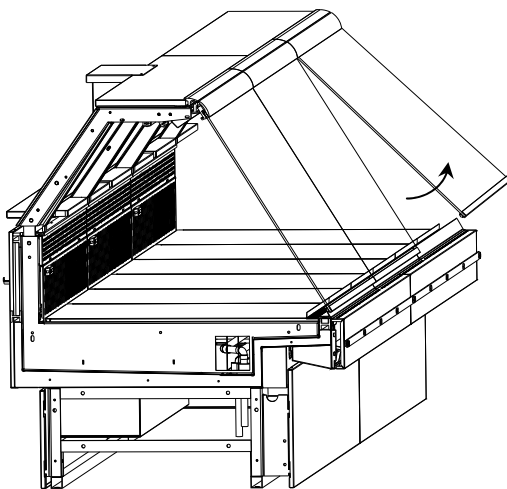

Model GLDS12R.5067 Shown Above

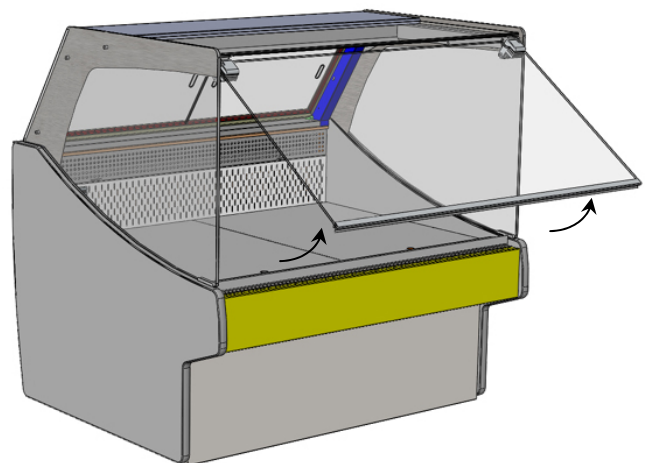

Model GLDSV4R Shown Above

INSTALLATION: FRONT GLASS ALIGNMENT & ADJUSTMENT (VIA RAIL SYSTEM)

Front Glass Alignment & Adjustment via Rail System (For Curved and Flat Front Glass)

- Proper alignment of the front glass is important to create and maintain a seal inside the case.
- Improper alignment can cause air leaks compromising the environment inside the case and create condensation.
- Follow the five steps listed below to assure proper front glass alignment.
- Illustrations shown may not exactly reflect every feature or option of your particular case.

1. **Side-to-Side Leveling:** Place a level on top of display case (parallel to front glass). Raise or lower either side of case by inserting shims under the rails to level the case (following steps 3 and 4 below).

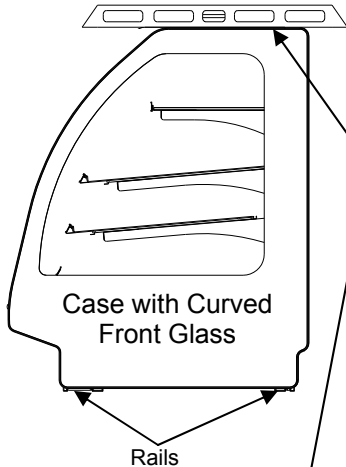

2. **Front-to-Back Leveling:**

- Place a level on top of case, perpendicular to the front glass.
- Raise or lower either side of case by shimming under the rails (following steps 3 & 4 below).
- Double-check the side-to-side level.

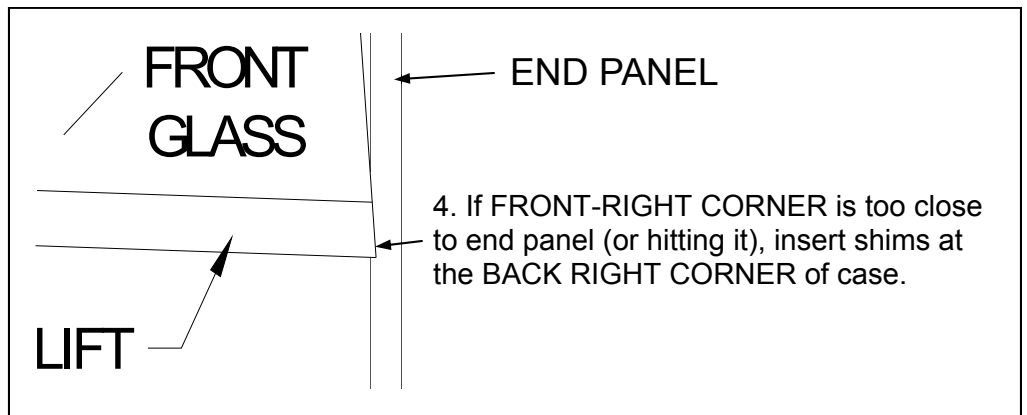
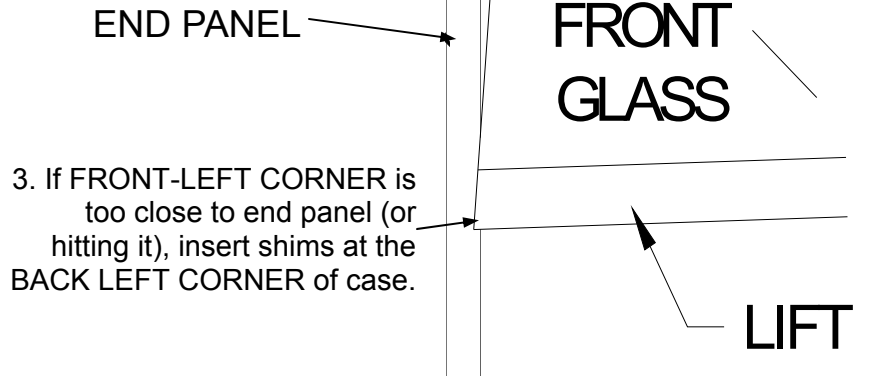
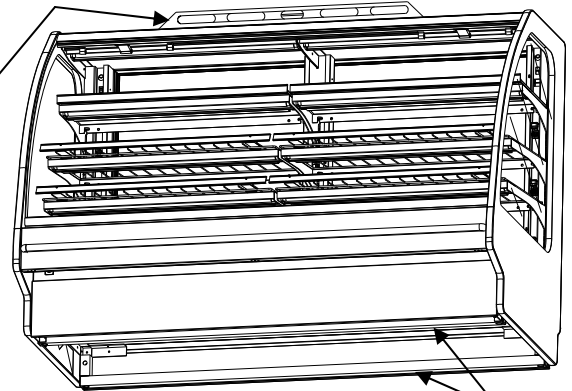

5. **Verification:**

- After inserting shims, open and shut the front glass.
- Verify (again) that the front glass is properly aligned at both left-hand and right-hand side of the case.
- If not, repeat the shimming procedure until the front glass is properly aligned along both sides of the case.

1. Scale Stand (Optional)

- Scale stand location and illustration is shown on this sheet.
- Route the scale stand cord through cord hole and into receptacle as shown at illustration at right.
- Plug scale stand cord into receptacle as shown in illustration at right.
- Depending upon options chosen, CAT 5 (Category 5) network cable outlet may also be available at scale stand base.

Note: Illustrations shown may not exactly reflect your particular model, features or options.

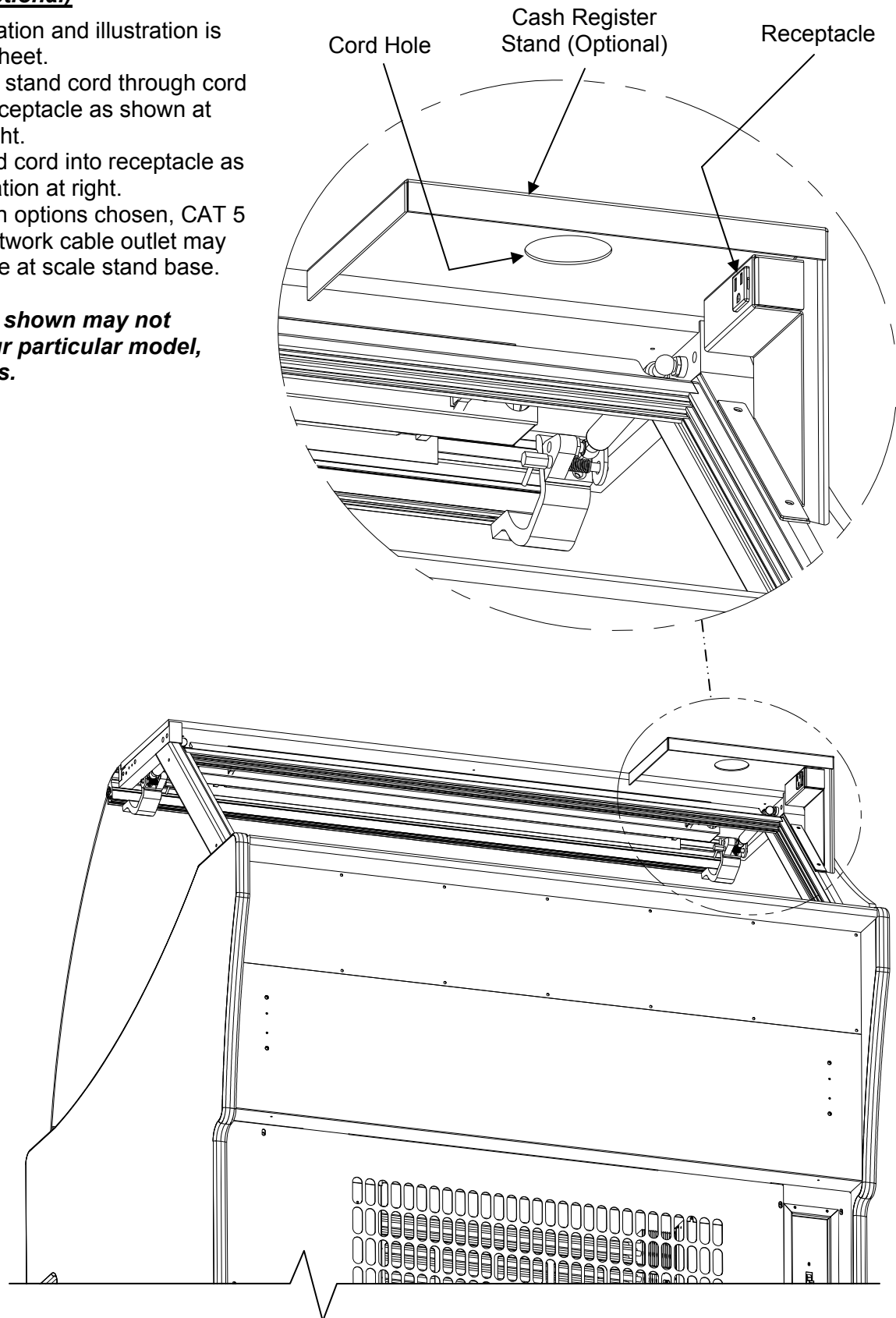

2. Locking Mechanism Option - Rear Sliding Doors

- Make certain doors are slid completely into “closed” position.
- Use SCC-provided key to lock rear sliding doors in place.
- To release rear sliding doors, simply use SCC-provided key to unlock unit.
- Place SCC-provided key in specific, accessible location to avoid loss.

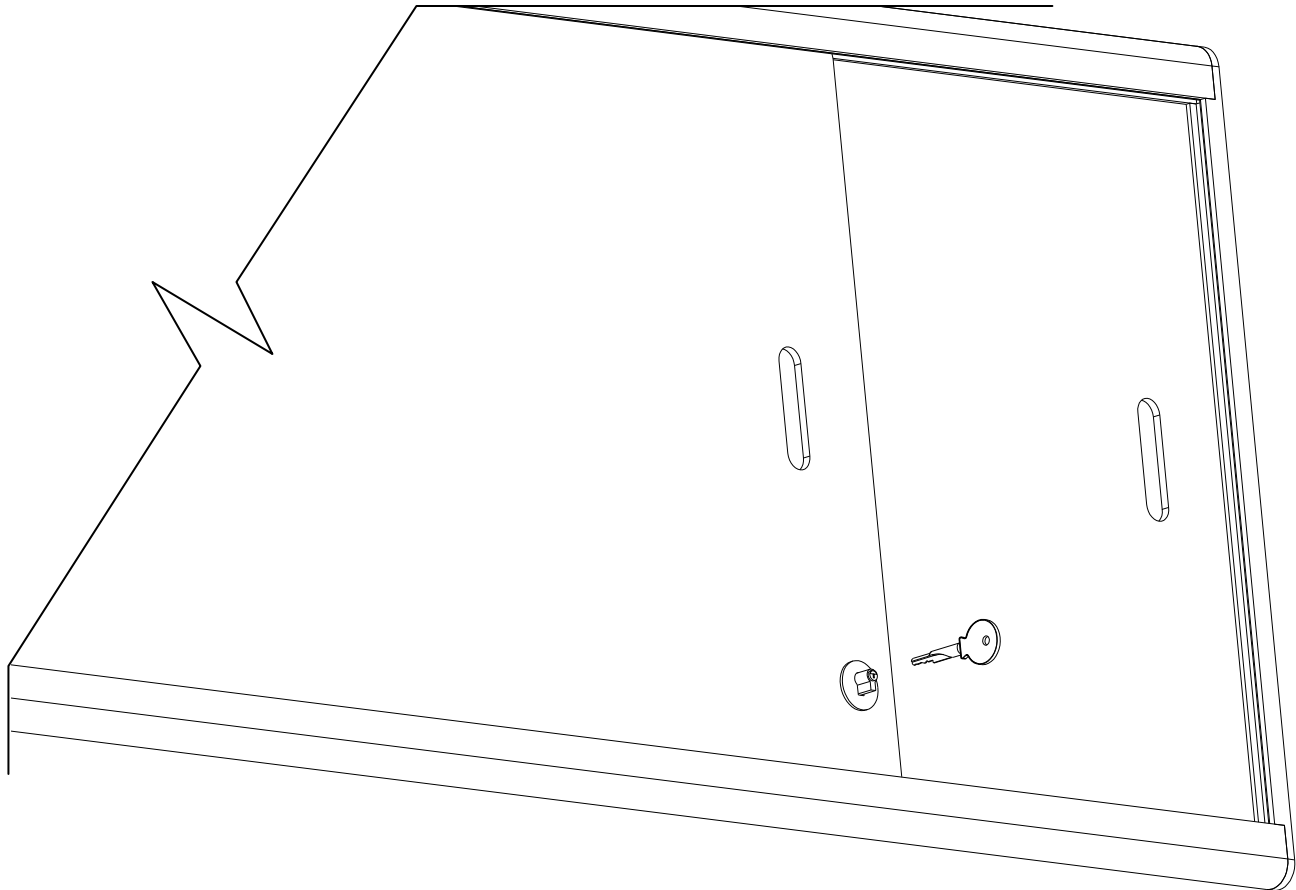

Above illustration shows rear sliding doors and the SCC-provided key ready to be inserted into lock.

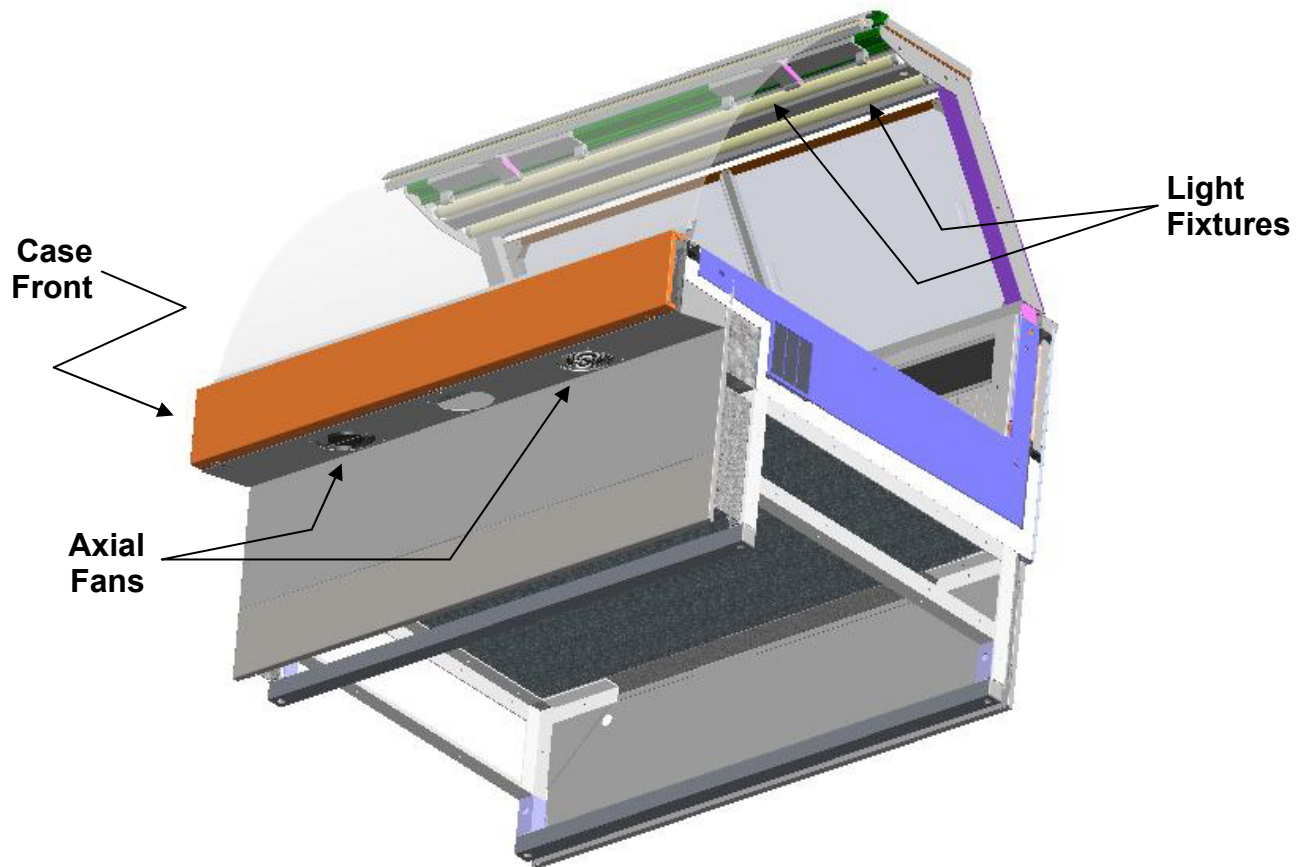

3. Light Fixtures

Warning! Disconnect power before providing maintenance and service to unit.

Caution: Lamps have been treated to resist breakage and must be replaced with similarly treated lamps.

Light fixtures are to be located on underside of shelf assembly, at the top inside of case, and lower front nose of case. See next page for light fixture locations.

Removal of lamp:

- Rotate lamp (1/4-turn) either direction to disengage (upper or lower) pins/contacts from lamp-mounting sockets.
- Remove bulb by applying even pressure from back side at bulb ends and pulling the remaining contact from sockets.

Installation of lamp:

- Align pins with slot.
- Insert pins into socket by rotating the bulb 1/4-turn to secure either the (upper or lower) pin contacts into the sockets.
- Rotate remaining bulb contacts (1/4-turn) into remaining lamp mounting socket contacts.

Note: Illustrations and photos shown may not exactly reflect every feature or option of your particular case.



DIPWELL™ OPERATION AND REMOVAL FOR CLEANING

Dipwell™ (Shown In Illustration Below) Is For Thawing Cold Scoops

- See cleaning schedule for specifics on cleaning Dipwell™.
- To remove Dipwell™ from case, it may be necessary to remove retaining screws.
- It may also be necessary to remove retaining clamp holding drain line to Dipwell™.
- Illustration below may not exactly reflect every feature or option of your particular Dipwell™ assembly.
- See **CLEANING SCHEDULE (TO BE PERFORMED BY STORE PERSONNEL)** section in this manual for specifics on cleaning.

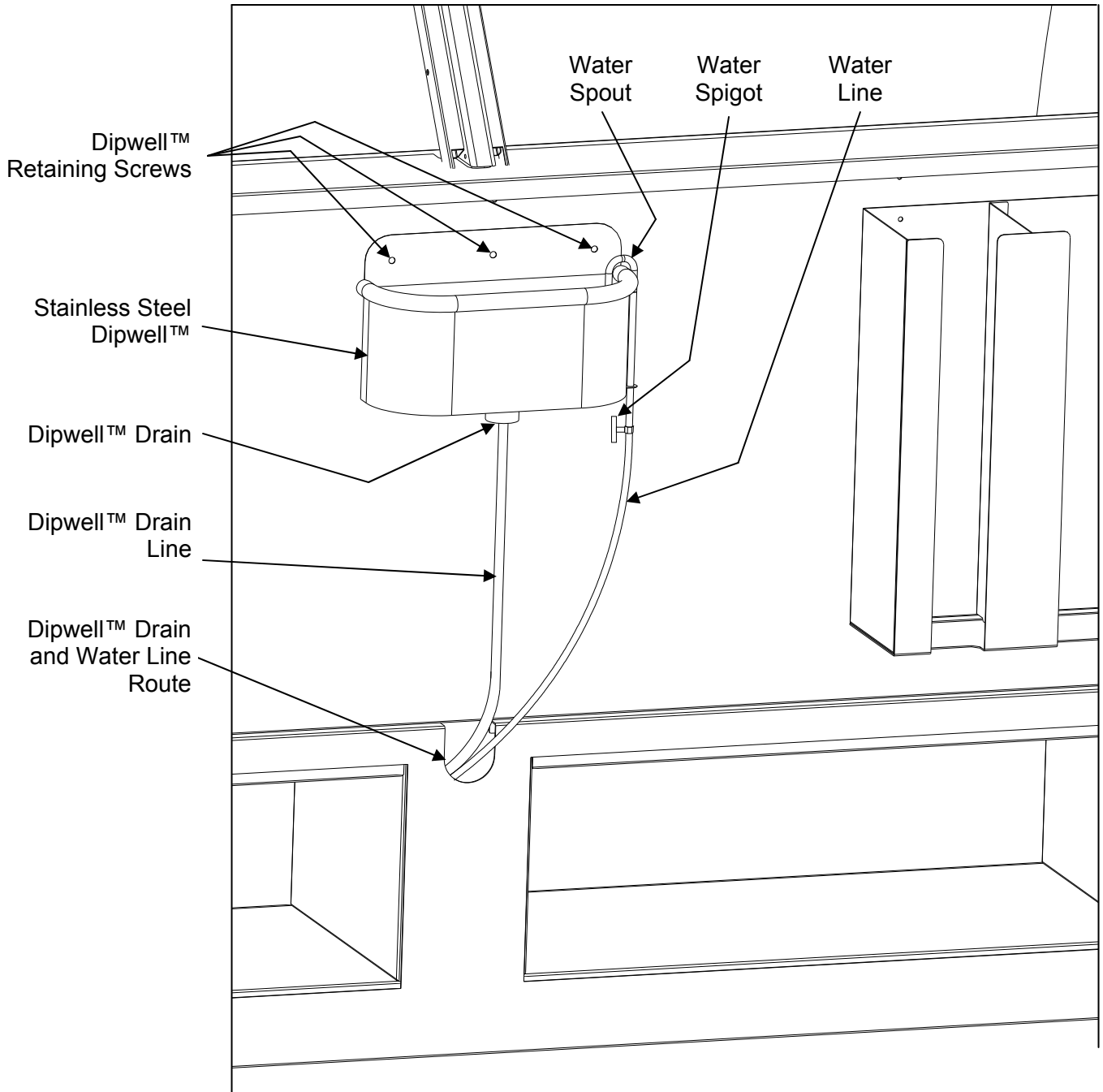

DIGITAL THERMOMETER / CAREL® TEMPERATURE CONTROLLER LOCATION & ACCESS

1. Digital Thermometer (Locations Vary)

- Thermometers provided with equipment reflect air temperature only (not actual food temperature).
- Use probe thermometers to determine actual food temperatures

2. Carel® Temperature Controller

- Temperature controllers are primarily placed on self-contained units.

- However, certain remote units (as model GLDS12R.5379 shown below) also have controllers.
- Access temperature controller by removing panel (as shown below); no screw removal is required.
- Temperature controller shown below is found at case rear; however, certain cases may have temperature controller at front of case.
- See **CAREL® TEMPERATURE CONTROLLER INFORMATION (PRIMARYLY FOUND ON SELF-CONTAINED UNITS ONLY)** section in this manual for more information.

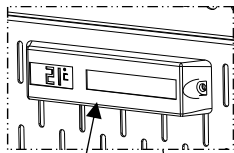

Thermometer

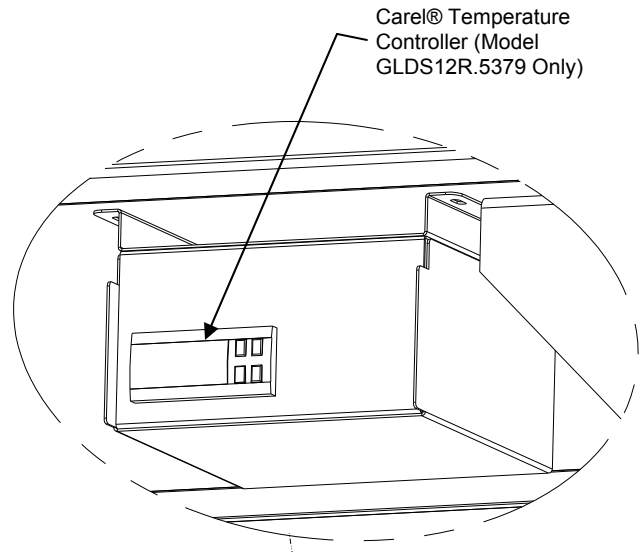
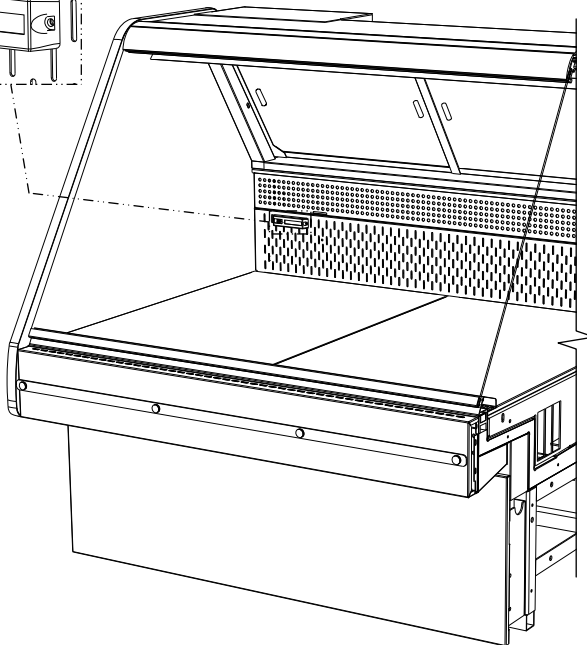

Carel® Temperature Controller (Model GLDS12R.5379 Only)

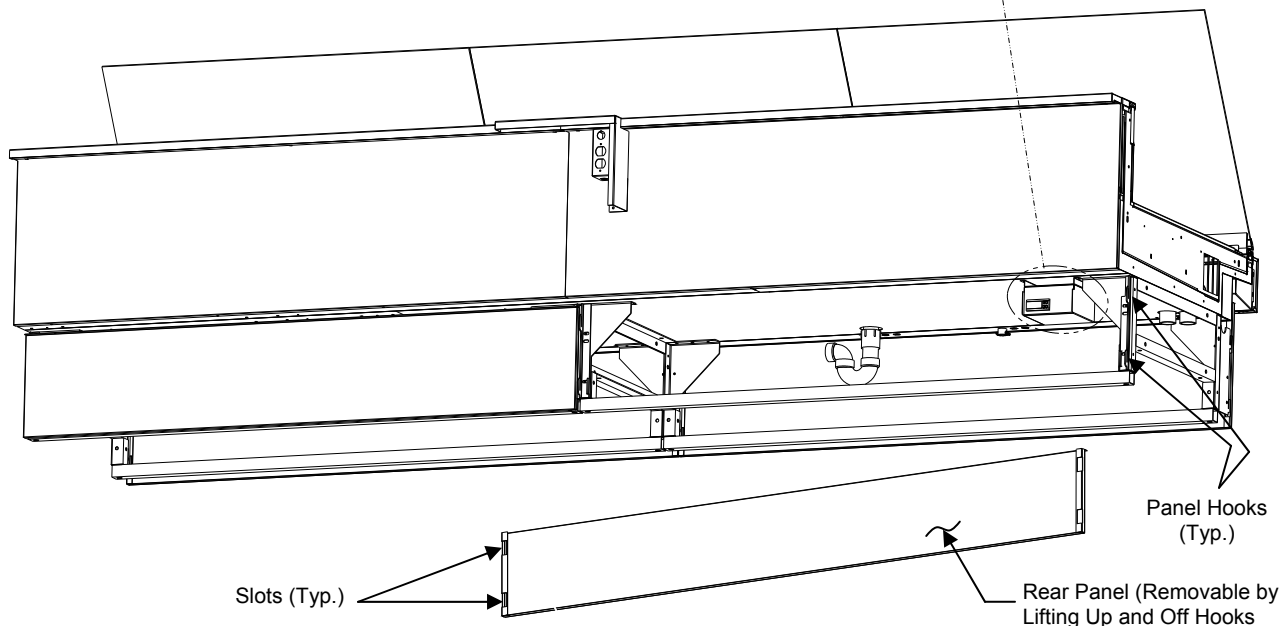

DRAIN / SHUT-OFF VALVE / BALANCE VALVE LOCATION & ACCESS

Drain / Shut-Off Valve / Balance Valve Access

- Access to valves and drain can be achieved by removing deck pans.
- All are accessible from front of case.
- Fans: Unplug fans and remove the fastener from the access panel in the front right (or left) side of the unit.
- See illustrations on this page for general location.
- **Caution!** Only authorized refrigeration technicians are to access valves!

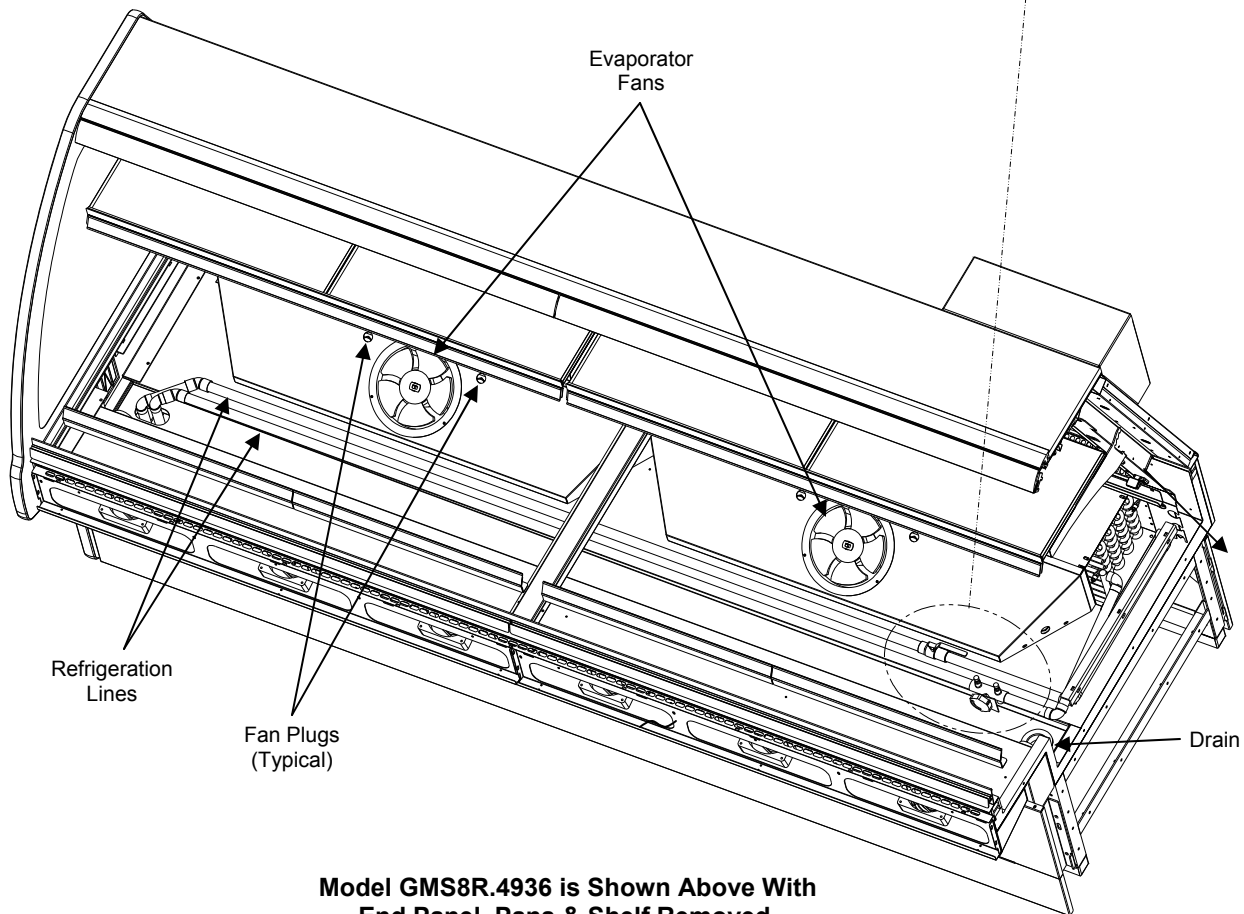
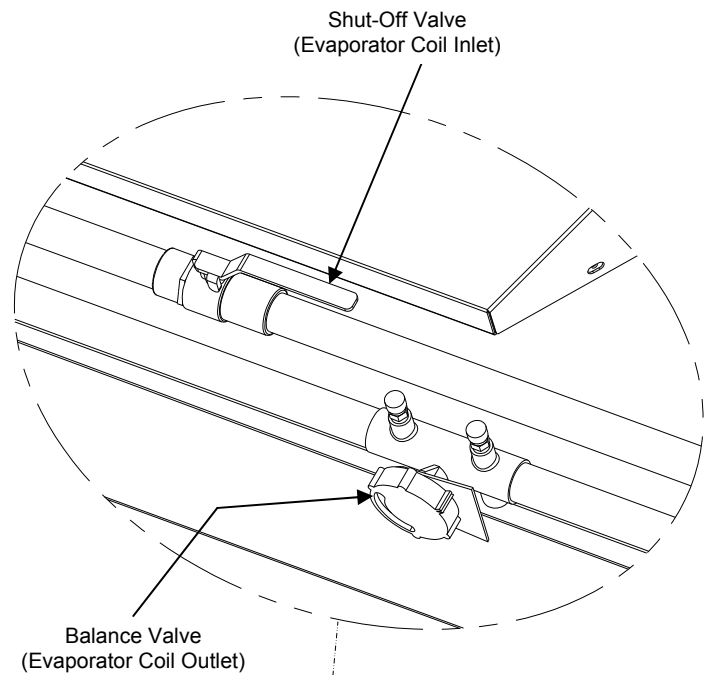

**Model GMS8R.4936 is Shown Above With
End Panel, Pans & Shelf Removed.
Your Case May Differ.**

METAL AIR DIFFUSER PLATE / REMOVAL / REPLACEMENT (FOR CERTAIN CASES)

Metal Air Diffuser Plate / Removal / Replacement

Metal air diffuser plate is perforated. It is located in discharge air duct. To access it, follow these instructions:

- Simply lift upward on metal air diffuser plate and out from case.
- See below illustration.
- After cleaning, be certain to replace metal air diffuser plate in same position so as not to disrupt airflow.

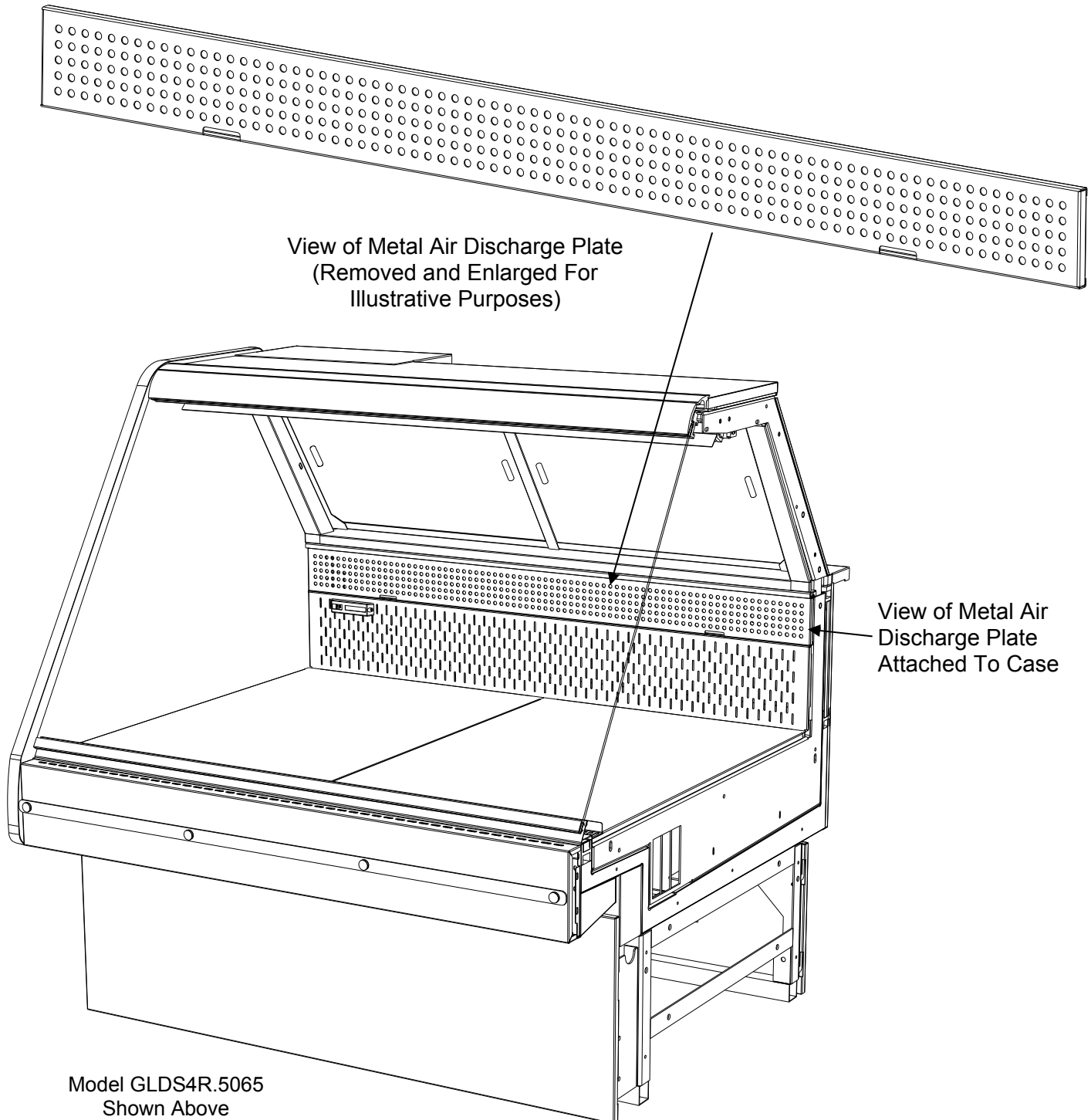

HONEYCOMB AIR DIFFUSER REMOVAL / REPLACEMENT (FOR CERTAIN CURVED CASES)

Honeycomb Air Diffuser Removal / Replacement For Curved Cases

- **Note:** See next page for Honeycomb Air Diffuser Removal / Replacement for Straight Cases.
- Honeycomb is located in discharge air duct. To access honeycomb, follow these instructions:
- Lift decks up and out.
- Grasp underside of panel back assembly (see illustration below). Lift up and out from case.
- To remove the honeycomb from the back panel assembly, simply squeeze (“pinch”) together and lift out from between retaining clips. See below illustration.
- **Caution! Heat tape wire is connected to panel back assembly!** To avoid disconnecting heat tape wire, keep panel back assembly within proximity of panel back area.
- After cleaning replace honeycomb in exact same position so as not to disrupt airflow.

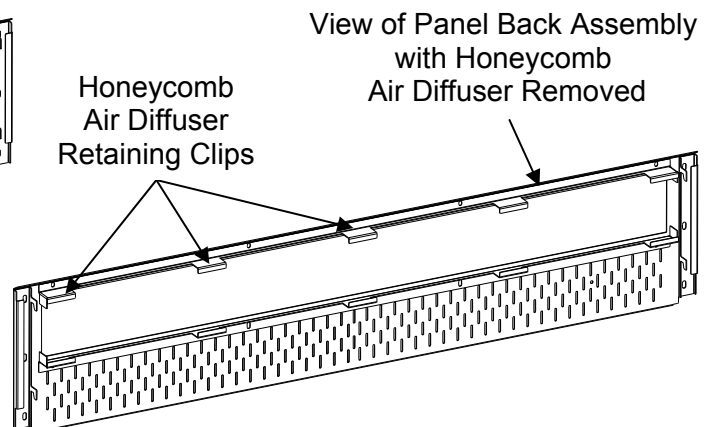
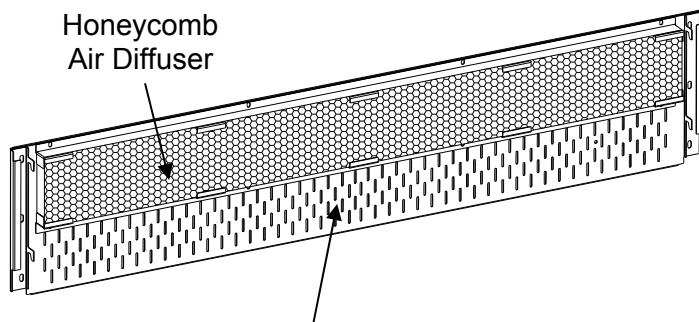
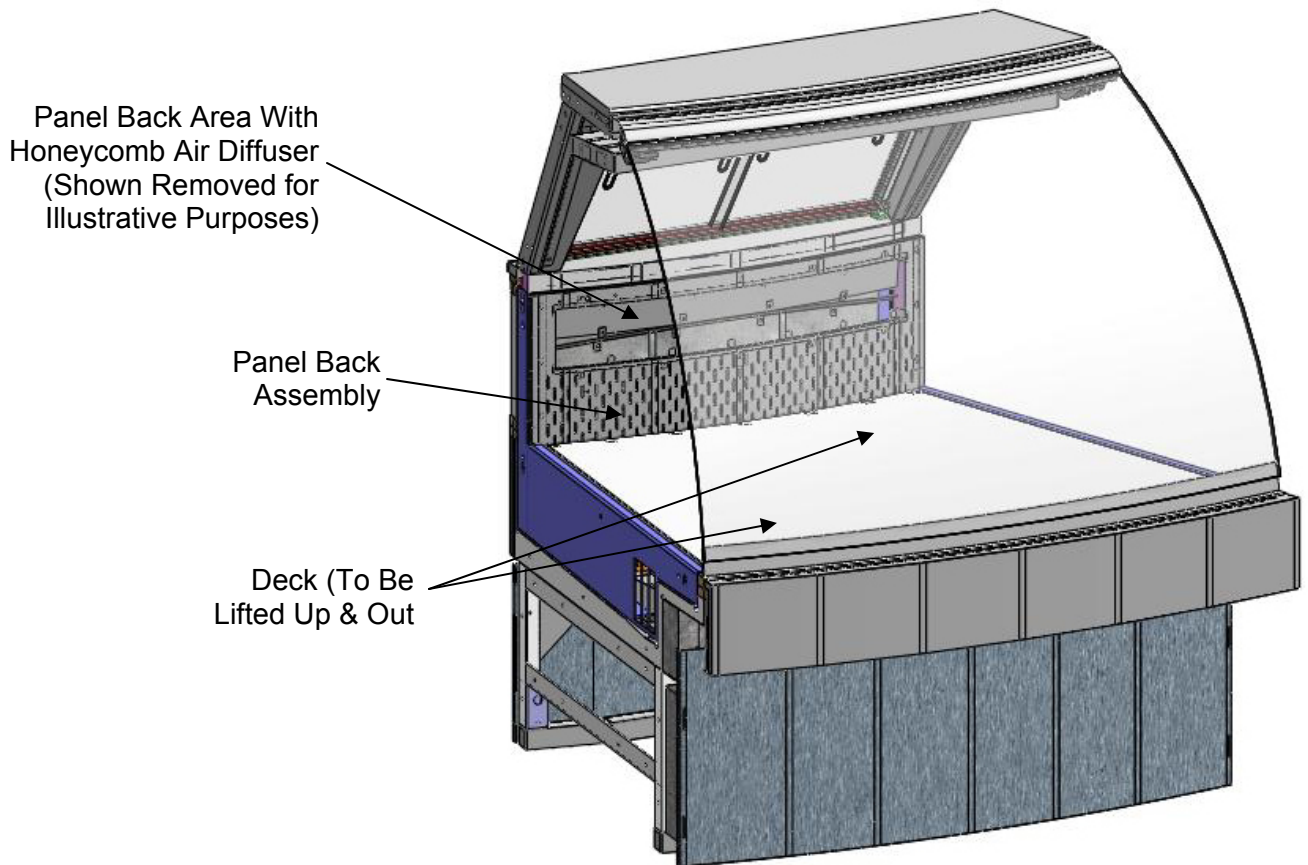

HONEYCOMB AIR DIFFUSER REMOVAL / REPLACEMENT (FOR CERTAIN STRAIGHT CASES)

Honeycomb Air Diffuser Removal / Replacement

- Honeycomb is located in discharge air duct.
- To access honeycomb, follow these instructions:
 1. Grasp tabs. Pull outward from rear plenum.
 2. Grasp underside of panel back assembly (as shown below). Lift up and out from case.
- To remove the honeycomb from the back panel assembly, simply squeeze ("pinch") together and lift out from between retaining clips. See below illustration.
- After cleaning, be certain to replace honeycomb in exact same position so as not to disrupt airflow.

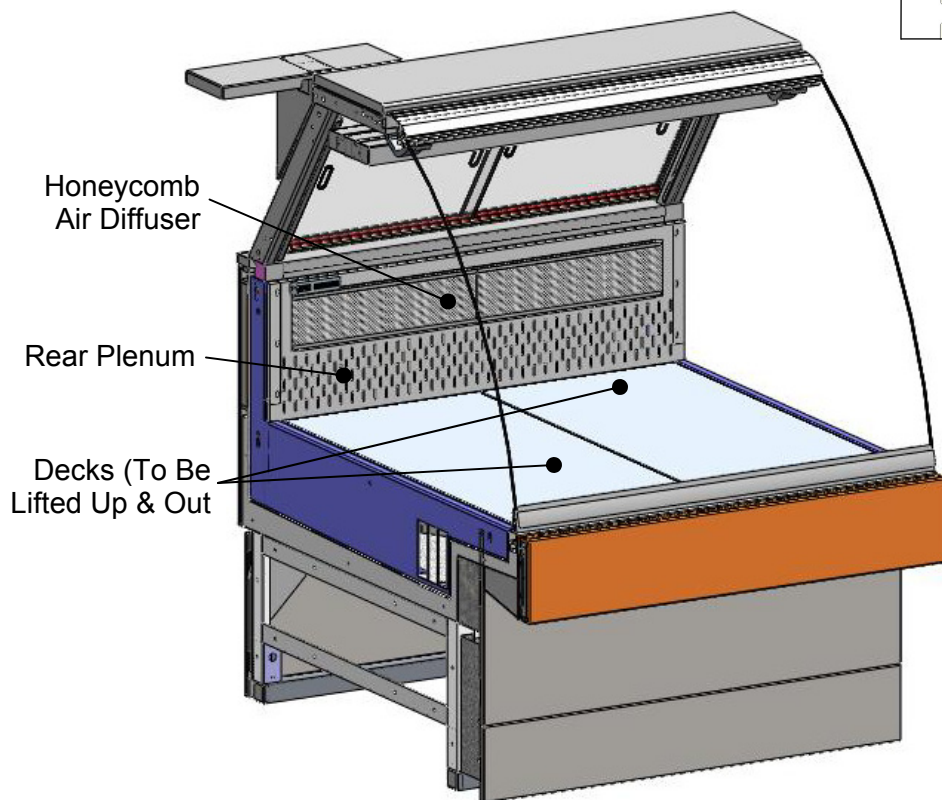

Honeycomb
Tabs

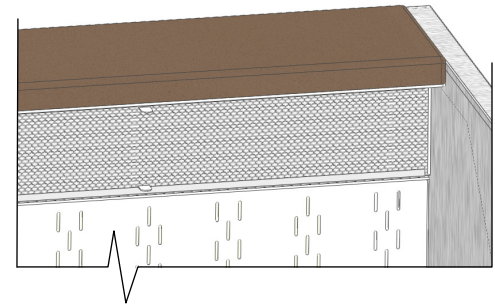
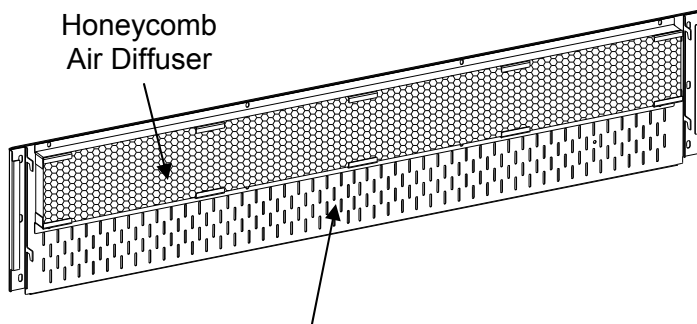
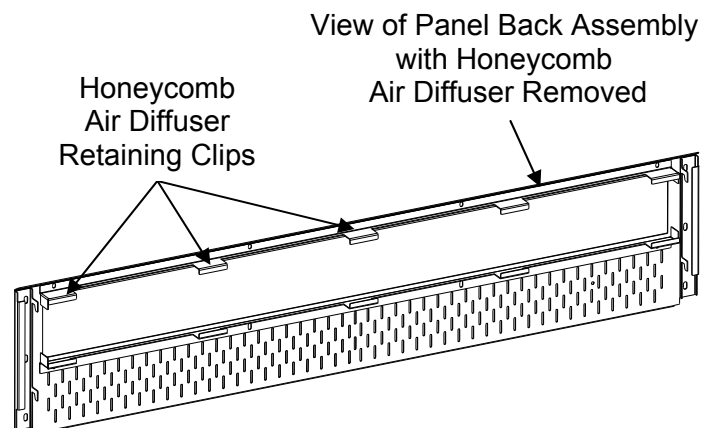

Illustration shown may not exactly reflect your model but is for illustrative purposes only.



View of Panel Back Assembly with
Honeycomb Air Diffuser Intact



CURVED GLASS ADJUSTMENT PROCEDURE

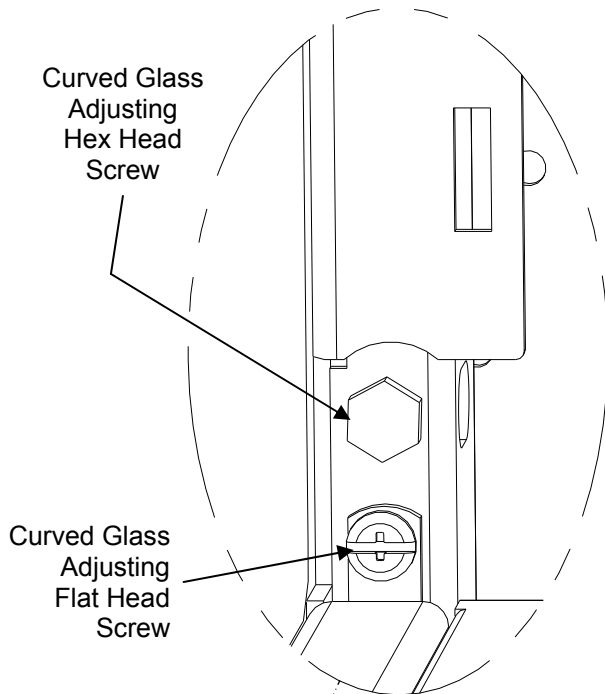

Curved Glass Adjustment Procedure

- **Views shown are after Honeycomb Air Diffuser Panel Back Assembly has been removed.**
 - **Curved Glass must be lifted up to access adjustable screws.**
1. **Use large flat head screwdriver to loosen flat head screw.**
 2. **Use 1/2" hex head socket to adjust hex head screw.**
 - a. **Adjusting hex head screw clockwise (inward) will lower curved glass downward.**
 - b. **Adjusting hex head screw counter-clockwise (outward) will raise glass upward.**
 3. **Adjust screws on BOTH sides of case in tandem to assure proper curved glass position.**
 4. **Raise and lower curved glass while at different screw positions to determine best fit.**
 5. **After achieving proper position, tighten flat head screws on BOTH sides of case.**

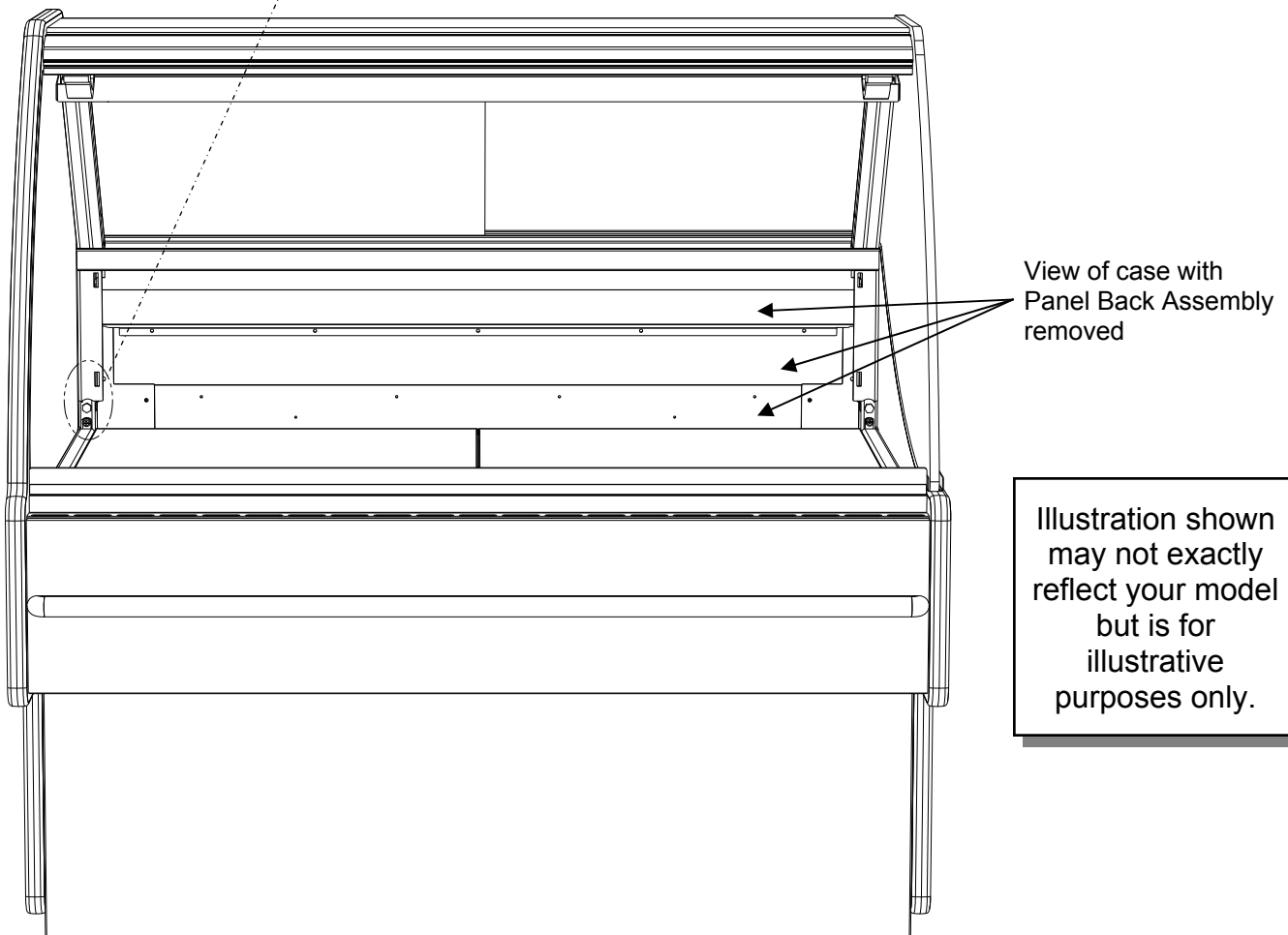



Illustration shown may not exactly reflect your model but is for illustrative purposes only.

Serial Label Location & Information Listed / Technical Information & Service



- Serial labels are located near the electrical access on your case.
- Serial labels contain electrical, temperature & refrigeration information, as well as regulatory standards to which the case conforms.
- For additional technical information and service, see the *TECHNICAL SERVICE* page in this manual for instructions on contacting Structural Concepts' Technical Service Department.
- See images below for samples of both refrigerated and non-refrigerated serial labels.



888 E. Porter Rd · Muskegon, MI 49441

ENCORE[®] MODEL HV74RSS SCROLL
SERIES SERIAL NO.

FOR PARTS AND SERVICE
CALL 1-800-433-9489

3048256
CONFORMS TO UL STD 471
CONFORMS TO NSF STD 7
CERTIFIED TO CAN/CSA
STD C22.2 NO 120

ELECTRICAL RATING 120/1/60 24A
REFRIGERANT R404A AMOUNT ?? OZ
DESIGN PRESSURE HIGH 450 LOW 200
MINIMUM CIRCUIT 30A
MAXIMUM OVERCURRENT 30A

SAMPLE ONLY

Super Heat Temp	8-10°F
BTUH Requirements	9,738 BTUH @ 20° F SST
Defrost	6 defrosts per day, 45° F termination, 45 min. failsafe

SAMPLE ONLY

SAMPLE ONLY

----- Sample Serial Label For Refrigerated Case -----



888 E. Porter Rd · Muskegon, MI 49441

Addenda[®] PC5682 txtRemote
txtSerialNumber

120 VOLTS 60 HZ SINGLE PHASE 1.84AMP

FOR PARTS OR SERVICE CALL
STRUCTURAL CONCEPTS
AT
1-800-433-9489



3048256
CONFORMS TO UL STD 65
CERTIFIED TO CAN/CSA
STD C22.2 NO 120

SAMPLE ONLY

----- Sample Serial Label For Non-Refrigerated Case -----

CLEANING SCHEDULE (TO BE PERFORMED BY STORE PERSONNEL)

NOTE: BOTH REMOTE AND SELF-CONTAINED UNITS ARE COVERED IN THE INFORMATION BELOW. IF YOUR CASE IS REMOTE, SELF-CONTAINED ITEMS WILL NOT APPLY TO YOUR CASE.

AREA TO CLEAN	FREQUENCY	INSTRUCTIONS
Case Exterior	Daily	Condensing Coil: Vacuum or brush grille area on back of case.
	Daily	Glass (Front Curved/Flat and/or Optional Rear Sliding Doors): Clean with a household or commercial glass cleaner. If tilting glass upward (or downward) be sure to return to original position.
	Daily	Front Panel (if Veneer): Do not use general cleaning solutions on veneer. Use Pledge™ or Murphy's Oil™. See illustration below for sample case with veneer on front panel.
	Daily	Cambria® Natural Quartz or Silestone® Natural Quartz: See next two pages for cleaning instructions on these solid surfaces.
	Daily	Dipwell™ Unit: Remove Dipwell™ Unit by removing three (3) screws. (see DIPWELL™ OPERATION AND REMOVAL FOR CLEANING section in this manual for illustration). Submerge in hot, soapy water and wash with sponge or clean cloth. Rinse, dry, and return to case. Clean area around case rear (where Dipwell™ is to be reattached) with hot, soapy water and clean cloth.
	Weekly	Rear Doors and Door Track (Optional): Remove rear doors and clean with a household or commercial cleaner. Clean door track with moist cloth.
	Weekly	Rear Storage Areas: Clean with a warm water and mild soap solution and soft cloth. Wipe dry with paper towel or soft cloth.
	Weekly	Lid Display (At Rear): <ul style="list-style-type: none"> • Wash with a solution of hand dishwashing liquid detergent and water; or a solution of baking soda and water. Rinse and polish dry with paper towel or soft cloth. • Never use scouring powders or steel wool as they will scratch stainless steel.
Case Interior	Weekly	Decks: Wipe off decks with moist cloth.

Overview - Cambria® Natural Quartz Surface

- Cambria is created from pure natural quartz, an extremely hard stone crystal mined directly from the earth. In fact, quartz is the hardest non-precious stone to be found in the earth's surface.
- Cambria is non-porous, making cleanup easy and preventing food and moisture from penetrating its surface (the main source of growth for harmful bacteria).
- Cambria has been certified by NSF International for use as a food preparation surface.



Cleaning - Cambria® Natural Quartz Surface

Clean as often as desired with warm water and a pH neutral, non-abrasive cleaner such as Formula 409® or Simple Green®. Rinse with clear, clean water. No sealing, buffing or re-polishing is necessary.

Other guidelines to observe:

- For dried spills, use a wet cotton cloth.
- Avoid bleach, alkaline (high pH) cleaners such as oven cleaner, abrasive cleaners such as Comet®, Soft Scrub® products, or other products containing pumice, SOS® pads, and other similar products, paint removers, furniture strippers, tarnish or silver cleaners or the like.
- Do not apply any sealers, penetrants or topical treatments to Cambria® under any circumstances.
- Natural stone surfaces can be damaged by sudden and rapid change of temperature especially near the edges, as well as direct or sustained heating of the top.
- Cambria® may not withstand the direct transfer of heat from pots and pans and other cooking units such as electric frying pans and griddles, and some crock-pots or roaster ovens and heat lamps. Therefore, the use of a hot pad or trivet is always recommended.
- Cambria® will resist stains from fruit juices, food coloring, coffee, tea, wine, grape juice, nail polish and felt tip markers.

CLEANING & MAINTENANCE of SILESTONE® NATURAL QUARTZ SURFACE BY COSENTINO

<p>Routine Care</p>	<p><u>For Daily, Routine Cleaning:</u> Silestone® requires very little maintenance. Simply wipe your Silestone surface with soap and warm water on a regular basis to maintain its beauty and shine for years to come. Any pH balanced general-purpose household cleaner may be used (e.g. dish soap, Windex®).</p>
<p>Difficult Spills</p>	<p><u>For Difficult Spills:</u> To remove difficult spills, wipe the surface with warm water and soap. If needed, apply a common household cleaner. For stains that harden as they dry, such as food, gum, nail polish, and paint, remove by gently scraping off of surface (using a blade or putty remover), and then clean using warm water and soap. Gray marks left by the razor, can be wiped away with soap and water. Silestone®'s advanced technology makes its surface extremely resistant to damaging chemicals. Difficult spots may be treated with one of the cleaners listed below. Leave the cleaner to sit for up to 10 minutes. Scrub and rinse thoroughly.</p> <ul style="list-style-type: none"> • Acetate • Lacquer Thinner • Rubbing Alcohol • Ammonia • Mineral Spirits • Vinegar • Formula 409® • Paint Thinner <p>Caution should be exercised in the handling and storage of any of the chemicals / products listed to the left. Each product's manufacturer's instructions should be consulted and utilized when using and storing these products.</p>
<p>Extreme Heat Protection</p>	<p><u>Extreme Heat Protection:</u> Silestone® is extremely resistant to heat, and can withstand moderately high temperatures for brief periods of time without being damaged. Although Silestone® is more heat resistant than any other stone surface, all stone can be damaged by sudden and extreme temperature changes, especially near the edges. For this reason, it is recommend that a trivet or a hot pad be used to protect the Silestone® surface from extreme heat.</p>
<p>Chemicals To Avoid</p>	<p><u>Chemicals To Avoid:</u> Avoid exposing your Silestone® surface to strong chemicals and solvents.</p> <ul style="list-style-type: none"> • <i>Items to avoid include: nail polish remover, permanent markers or inks, oil soaps, and furniture cleaners or paint strippers that contain trichlorethane or methylene chloride.</i> • Also avoid exposing you Silestone® surface to chemicals with high alkaline/PH levels, such as oven cleaners. <p>Caution must be used for the following:</p> <ul style="list-style-type: none"> • Products containing oils or powders may leave a residue. • Repetitive use of abrasive scrubs/cleaners may dull Silestone®'s finish. • Use of oven/grill cleaner may discolor Silestone® and should be avoided. • Repetitive exposure to extreme heat may damage Silestone's finish. <p>Apparent stains like coffee, food, makeup, etc.:</p> <ul style="list-style-type: none"> • Apply the appropriate cleaner with a paper towel and wipe. If necessary, the area may be soaked with pads of paper towels from 3-10 minutes; • Scrub the area. Rinse thoroughly. Dry thoroughly.
<p>Extreme Scratch Protection</p>	<p><u>Extreme Scratch Protection:</u> Although Silestone® is extremely scratch resistant, Silestone® surface should be protected by using a cutting board to avoid damage to knives.</p>

TROUBLESHOOTING

NOTE: BOTH REMOTE AND SELF-CONTAINED UNITS ARE COVERED IN THE INFORMATION BELOW. IF YOUR CASE IS REMOTE, SELF-CONTAINED ITEMS WILL NOT APPLY TO YOUR CASE.

CONDITION	TROUBLESHOOTING
Case Not Lining Up	See Installation Section for instructions on properly aligning case (alongside other cases) and adjusting levelers.
Water Is On The Floor	<u>Trained Service Providers Only:</u> Check that drain trap is free of debris.
	Check that the drain hose is correctly positioned over condensate pan (or floor drain, for remote units).
	Check store conditions. Conditions should be 55% humidity / 75 °Fahrenheit to prevent condensation.
	<u>Trained Service Providers Only:</u> Check that condensate pan is plugged in.
	<u>Trained Service Providers Only:</u> Check evaporator pan float for proper operation.
	<u>Trained Service Providers Only:</u> Check that evap. pan is heating.
Fan Emits Excessive Noise	Check that the case is aligned, level and plumb.
	<u>Trained Service Providers Only:</u> Check condensate fan for cleanliness.
	<u>Trained Service Providers Only:</u> Unplug/power off fan motors. Check motor shaft for excessive bearing wear.
	<u>Trained Service Providers Only:</u> Check that fan motors are securely mounted in brackets.
	<u>Trained Service Providers Only:</u> Verify that fan blades are securely mounted to fan motor.
	<u>Trained Service Providers Only:</u> Check that nothing is preventing blade rotation.
	<u>Trained Service Providers Only:</u> Check that the fan shroud is properly secured.
Fans Are Not Working	Check that the MAIN power switch is on.
	<u>Trained Service Providers Only:</u> Check that fans are plugged in at the fan shroud.
	<u>Trained Service Providers Only:</u> Check for foreign material obstructing fan performance.
	<u>Trained Service Providers Only:</u> Check that fan blades freely rotate within fan shrouds
	<u>Trained Service Providers Only:</u> Check that power is going to fans
	<u>Trained Service Providers Only:</u> Check that fan wiring is connected on terminal blocks.

TROUBLESHOOTING, CONTINUED

NOTE: BOTH REMOTE AND SELF-CONTAINED UNITS ARE COVERED IN THE INFORMATION BELOW. IF YOUR CASE IS REMOTE, SELF-CONTAINED ITEMS WILL NOT APPLY TO YOUR CASE.

CONDITION	TROUBLESHOOTING
Case Lights Are Not Working, continued.	Check that Light switch is in the <i>on</i> position.
	Check for burned out bulbs. Turn lights off & replace.
	Clean dirt and dust from the bulbs to prevent flickering.
	<u>Trained Service Providers Only</u> : Check that voltage is at ballasts. If voltage is entering but not exiting ballast, ballast is faulty.
Control Display Is Flashing	<i>See Temperature Controller Section for Model's particular Thermostat Controller Operation's Settings</i>
Case Is Not Holding Temperature	If a large amount of warm product was added to the case, it will take time for the temperature to adjust. Unit needs product to be pre-chilled.
	Temperature changes during defrost mode but will return to normal. Fourth LED will indicate defrost cycle in progress.
	Check that the case is not in the sun or near a heat or air-conditioning vent.
	If case is located near front doors, temperature fluctuation can hinder unit's ability to maintain temperature.
	Check that condenser coil has been cleaned.
	Check air grilles for obstructions.
	<u>Trained Service Providers Only</u> : Check sight glass for flashing and/or low charge.
	<u>Trained Service Providers Only</u> : Check Set Point Temperature; it may be adjusted too high.
Condensing Unit Is Not Operating	Carefully review Controller's Settings for accuracy. <i>See Temperature Controller Section for Model's particular Thermostat Controller Operation's Settings.</i>
Digital Control Display Is Blank	Check that the MAIN power switch is on.
	<u>Trained Service Providers Only</u> : Check the circuit breaker box for tripped circuits.
System Is Not Operating	Check that the utility power is on.
	Check that the MAIN power switch is on.
	<u>Trained Service Providers Only</u> : Check the circuit breaker box for tripped circuits.
Case Lights Are Not Working	Turn lights off and then check bulbs for proper connection.

PREVENTIVE MAINTENANCE	FREQUENCY	INSTRUCTIONS
Case Exterior (Self-Contained Units Only)	Monthly	<p>Condensing Coil: <i>Disconnect power from case before cleaning the Condensing Coil!</i></p> <ul style="list-style-type: none"> • Remove Rear Grille (by removing 4 screws). • Roll / Slide out Refrigeration Assembly. <i>Note:</i> At initial slide-out, it may be necessary to remove two (2) Compressor Pan Shipment Screws for Refrigeration Assembly to slide out. • Use air pressure or industrial strength vacuum; clean dust and dirt that may collect on the Condenser Coil. See illustration below. • Caution! Coil fins are sharp. Handle with care! • Slide/Roll Condensing Unit Assembly back under case. • Replace Rear Grille to case (4 screws). • See illustration below.
Case Exterior (Self-Contained Units Only)	Quarterly	<p>Optional Clean Sweep™ Condensing Coil: <i>Disconnect power from case before cleaning Clean Sweep™ Condenser Coil!</i></p> <ul style="list-style-type: none"> • Remove Rear Grille (by removing 4 screws). • Slide/Roll out condensing unit assembly. • Remove the four (4) screws holding the Clean Sweep™ rails intact. • Remove the Clean Sweep™ rail. • Wash rails' brushes in hot water and mild soap solution. • If brushes are worn, they must be replaced. Call Technical Service Department to replace. Toll-Free number is listed at end of manual. • Clean Condensing Coil: Use air pressure or industrial strength vacuum; clean the dust and dirt that may collect on the Condenser Coil. • Caution! Coil fins are sharp. Handle with care! • Reattach Clean Sweep rail to condensing unit (4 screws). • Slide/Roll Condensing Unit Assembly back under case. • Replace Rear Grille to case (4 screws). • See photos below.

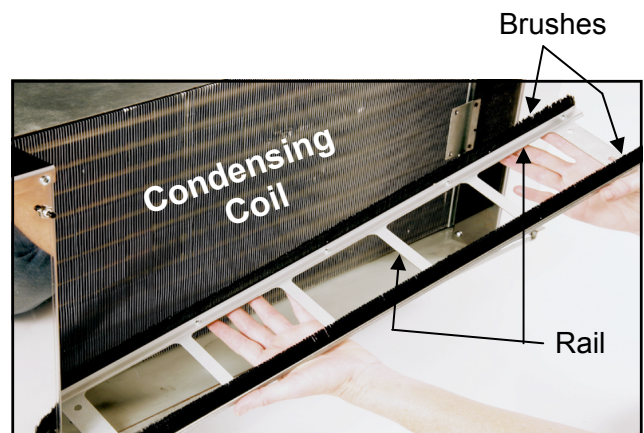
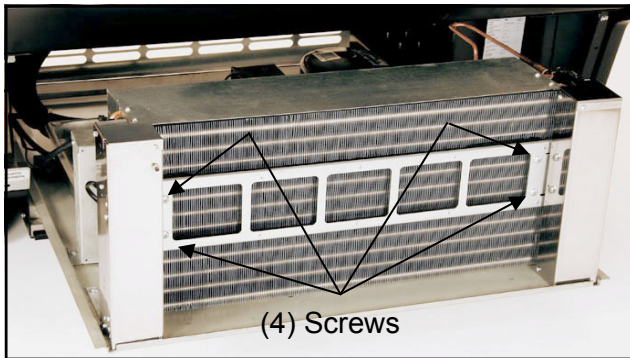

--- Above photos are taken after rear grille has been removed from case ---

PREVENTIVE MAINTENANCE	FREQUENCY	INSTRUCTIONS
Case Exterior	Quarterly	<p><u>Compressor Area (Self-Contained Units Only):</u> <i>Disconnect power from case before cleaning Condenser Coil!</i></p> <ul style="list-style-type: none"> • Slide/Roll out from under case. • Use moist cloth to wipe off dust & debris that collects on various parts.
	Quarterly	<p><u>Condensate Pan (Self-Contained Units Only):</u> Disconnect from receptacle box. Remove mounting screw(s) from base. Use a de-scaling solution (such as CLR® that will prevent corrosion, lime and rust) to clean pan. Rinse thoroughly; do not submerge in water.</p>
	Quarterly	<p><u>Under Case Cleaning:</u> Once refrigeration package is clear of unit, vacuum under case to remove all dust and dirt that may collect under case.</p>
Case Interior	Quarterly	<p><u>Tub, Coil and Drain (Self-Contained Units Only):</u> Remove Evaporator Fan Panel and clean Tub, Coil and Drain with warm water and mild soap solution. Remove any debris that may clog drain.</p>
	Quarterly	<p><u>Fan Blades, Motor, and Bracket:</u> Wipe down each blade, motor and bracket with moist cloth.</p>
	Quarterly	<p><u>Honeycomb:</u> Remove the honeycomb. Vacuum, then clean with warm water and soap. See <i>HONEYCOMB AIR DIFFUSER REMOVAL / REPLACEMENT</i> sheet in this manual for removal / replacement instructions.</p>

CAREL

ir33 platform

Integrated Electronic
Microprocessor Controller



Programming The Instrument

To Modify The Setpoint

Set 1. Press and hold the "SET" key for at least 1 second.

aux **def** 2. Use arrow keys ▲ ▼ on temperature controller to increase (or decrease) the setpoint.

Set 3. Quickly press and release the "SET" key again.

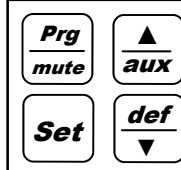

To Modify Defrost, Differential, Other Parameters

Prg mute **Set** 1. Press & hold "Prg" & "SET" keys together for five (5) seconds; display will flash "0", representing password prompt.

Set 2. Confirm by pressing "SET" key.

aux **def** 3. Press ▲ or ▼ to reach the category to be modified.

Set 4. Press "SET" to modify this selected parameter.

aux **def** 5. Increase or decrease the value using the ▲ or ▼ button respectively.

Set 6. Press the "SET" key to temporarily save the new value and return to the display of the parameter.

Prg mute 7. Press & hold the "Prg" key for at least 5 seconds to save changes. This action will also mute the audible alarm (buzzer) & deactivate the alarm relay.

How To Change Reading From Fahrenheit (°F) To Celsius (°C)

Prg mute **Set** 1. Press and hold "Prg" and "SET" keys together for at least 5 seconds; display will show "0" (password prompt).

Set 2. Confirm by pressing "SET" key.

aux **def** 3. Press ▲ or ▼ until reaching the parameter "/ 5".

Set 4. Press "SET" to modify this selected parameter.

aux **def** 5. Press ▲ or ▼ to change value to desired setting: "0" for Celsius (°C) or "1" for Fahrenheit (°F).

Set 6. Press "SET" key to temporarily save the new value and return to the display of the parameter.

Prg mute 7. Press & hold "Prg" key for at least 5 seconds to save changes. **Note! All values will automatically convert to new scale. No conversion is required.**

Warning! Save Your Parameter Settings!

1. To store the new parameter values, PRESS and HOLD the "Prg" key for at least 5 seconds.
2. All modifications made to parameters will be lost if you do NOT press a button within 60 seconds. Should this "timeout" occur, normal operational settings (prior to modifications being made) will resume.
3. If the instrument is switched off before pressing the "Prg" key, all modifications to parameters will be lost.

def **To Activate Manual Defrost**
Press and hold "def" key for at least 5 seconds.

aux **To Activate / Deactivate Auxiliary Output**
Press and hold the "aux" key for 1 second.

Prg mute **aux** **To Reset Any Alarms With Manual Reset**
Press and hold the "Prg" and "aux" key for at least 1 second.

CAREL

ir33 platform
**Integrated Electronic
 Microprocessor Controller**



User Interface - Display

ICON	FUNCTION	DESCRIPTION	Normal operation			Start up
			ON	OFF	BLINK	
	COMPRESSOR	ON when the compressor starts. Flashes when the activation of the compressor is delayed by safety times.	Compressor on	Compressor off	awaiting activation	
	FAN	ON when the fan starts. Flashes when the activation of the fan is prevented due to external disabling or procedures in progress.	Fan on	Fan off	awaiting activation	
	DEFROST	ON when the defrost is activated. Flashes when the activation of the defrost is prevented due to external disabling or procedures in progress.	Defrost in progress	Defrost not in progress	awaiting activation	
	AUX	Flashes if the anti-sweat heater function is active, ON when the auxiliary output (1 and/or 2) selected as AUX (or LIGHT in firmware version 3.6) is activated.	AUX auxiliary output active (version 3.6 light auxiliary output active)	AUX auxiliary output not active	Anti-sweat heater function active	
	ALARM	ON following pre-activation of the delayed external digital input alarm. Flashes in the event of alarms during normal operation (e.g. high/low temperature) or in the event of alarms from an immediate or delayed external digital input.	Delayed external alarm (before the time 'A7' elapses)	No alarm present	Alarms in norm. operation (e.g. High/low temperature) or immediate or delayed alarm from external digital input	
	CLOCK	ON if at least one timed defrost has been set. At start-up, comes ON for a few seconds to indicate that the Real Time Clock is fitted.	If at least 1 timed defrost event has been set	No timed defrost event set	Alarm clock	ON if real-time clock present
	LIGHT	Flashes if the anti-sweat heater function is active, ON when the auxiliary output (1 and/or 2) selected as LIGHT is activated (in firmware version 3.6 it does not flash in anti-sweat heater mode and comes on when the dead band output is active).	Light auxiliary output on (version 3.6 dead band auxiliary output active)	Light auxiliary output off	Anti-sweat heater function active (version 3.6 does not flash in anti-sweat heater mode)	
	SERVICE	Flashes in the event of malfunctions, for example E2PROM errors or probe faults.		No malfunction	Malfunction (e.g. E2PROM error or probe fault). Contact service	
	CONTINUOUS CYCLE	ON when the CONTINUOUS CYCLE function is activated. Flashes if the activation of the function is prevented due to external disabling or procedures in progress (E.g.: minimum compressor OFF time).	CONTINUOUS CYCLE operation activated	CONTINUOUS CYCLE function not activated	CONTINUOUS CYCLE operation requested	

Summary Table of Alarm and Signals: Display, Buzzer and Relay

Code	Icon on the display	Alarm relay	Buzzer	Reset	Description
rE	flashing	on	on	automatic	virtual control probe fault
E0	flashing	off	off	automatic	room probe S1 fault
E1	flashing	off	off	automatic	defrost probe S2 fault
E2	flashing	off	off	automatic	probe S3 fault
E3	flashing	off	off	automatic	probe S4 fault
E4	flashing	off	off	automatic	probe S5 fault
'	No	off	off	automatic	probe not enabled
LO	flashing	on	on	automatic	low temperature alarm
HI	flashing	on	on	automatic	high temperature alarm
AFr	flashing	on	on	manual	antifreeze alarm
IA	flashing	on	on	automatic	immediate alarm from external contact
dA	flashing	on	on	automatic	delayed alarm from external contact
dEF	on	off	off	automatic	defrost running
Ed1	No	off	off	automatic/manual	defrost on evaporator 1 ended by timeout
Ed2	No	off	off	automatic/manual	defrost on evaporator 2 ended by timeout
Pd	flashing	on	on	automatic/manual	maximum pump down time alarm
LP	flashing	on	on	automatic/manual	low pressure alarm
AtS	flashing	on	on	automatic/manual	autostart in pump down
cht	No	off	off	automatic/manual	high condenser temperature pre-alarm
CHT	flashing	on	on	manual	high condenser temperature alarm
dor	flashing	on	on	automatic	door open too long alarm
EE	flashing	off	off	automatic	E2prom error, unit parameters
EF	flashing	off	off	automatic	E2prom error, operating parameters
ccb	Signal				start continuous cycle request
ccE	Signal				end continuous cycle request
dFb	Signal				start defrost call
dFE	Signal				end defrost call
On	Signal				switch ON
off	Signal				switch OFF
rES	Signal				reset alarms w/manual reset / reset HACCP alarms / reset temp. monitoring

CAREL

ir33 platform

Integrated Electronic
Microprocessor Controller



Summary Table of Operating Parameters

CODE	PARAMETER	UOM*	TYPE	MINIMUM	MAXIMUM	DEFAULT
/5	Select Celsius (°C) or Fahrenheit (°F)	flag	C	0	1	For Case Specific Defaults See Serial Label Located Near Electrical Access On Your Case. For Additional Technical Information Call Structural Concepts Technical Service Dept. at 1(800) 433.9489
/c1	Calibration of probe 1	°C/°F	C	-20	20	
/c2	Calibration of probe 2	°C/°F	C	-20	20	
St	Temperature set point	°C/°F	F	r2	r1	
rd	Control delta	°C/°F	F	20	0.1	
dl	Interval between defrosts	hours	F	0	250	
dt1	End defrost temperature, evaporator	°C/°F	F	-50	200	
dP1	Maximum defrost duration, evaporator	min	F	1	250	
d6	Display on hold during defrost	-	C	0	2	
dd	Dripping time after defrost	min	F	0	15	
d/1	Display of defrost probe 1	°C/°F	F	-	-	

* Unit Of Measure

STRUCTURAL CONCEPTS CORPORATION TECHNICAL SERVICE
PHONE NUMBER: 1.800.433.9489 or For Your Master Service Agent See
WWW.STRUCTURALCONCEPTS.COM/Contact/Master_Service_Agents.asp

LIMITED WARRANTY

All sales by Structural Concepts Corporation (SCC) are subject to the following limited warranty. "Goods" refers to the product or products being sold by SCC.

Warranty Scope: Warranty is for equipment sold in the United States, Canada, Mexico and Puerto Rico. Equipment sold elsewhere may carry modified warranty.

Warranty; Remedies; Limitations. The limit of liability of SCC toward the exchange cost of the original compressor motor (and/or any other components) is one year parts and labor. If any Goods are found to be of faulty material or workmanship within one year of the original F.O.B. unit shipment, SCC will, at its option (after inspection by an authorized representative), replace or pay the reasonable cost of replacement of the faulty Goods. If warranty claim is not made within this one year time period, SCC is not bound to warrant Goods. A motor-compressor (and/or any other components) replaced during the warranty shall not exceed manufacturer's current established wholesaler's exchange price. If replacement motor-compressor (and/or other components) is available via storage facility, parts truck, etc., SCC mandates that readily accessible replacement components be used toward repair of Goods; in such instances, SCC will replace such equipment (at its own expense) after confirmation of its use/placement on defective unit. SCC shall not be charged an additional fee, up-charge or expense for such replacement Goods. If SCC is unable to repair or replace the defective Goods, SCC shall issue a credit to the Purchaser for full or partial purchase price, as SCC shall determine. The replacement or payment in the manner described above shall be the sole and exclusive remedy to Purchaser for a breach of this warranty. If any Goods are defective or fail to conform to this warranty, SCC will furnish instructions for their disposition. No Goods shall be returned to SCC without its prior consent.

SCC's liability for any defect in the Goods shall not exceed the purchase price of the Goods. SCC SHALL HAVE NO LIABILITY TO PURCHASE FOR CONSEQUENTIAL DAMAGES OF ANY KIND WHATSOEVER, INCLUDING, BUT NOT LIMITED TO, PERSONAL INJURY, PROPERTY DAMAGE, LOST PROFITS, OR OTHER ECONOMIC INJURY DUE TO ANY DEFECT IN THE GOODS OR ANY BREACH OF SCC, SCC SHALL NOT BE LIABLE TO THE PURCHASER IN TORT FOR ANY NEGLIGENT DESIGN OR MANUFACTURE OF THE GOODS, OR FOR THE OMISSION OF ANY WARNING THEREFROM.

SCC shall have no obligation or liability under this warranty for claims arising from any other party's (including Purchaser's) negligence or misuse of the Goods or environmental conditions. This warranty does not apply to any claim or damage arising from or caused by improper storage, handling, installation, maintenance, or from fire, flood, accidents, structural defects, building settlement or movement, acts of God, or other causes beyond SCC's control.

Except as expressly stated herein, SCC makes no warranty, express, implied, statutory or otherwise as to any parts or goods not manufactured by SCC. SCC shall warrant such parts or Goods only (I) against such defects, (II) for such periods of time, and (III) with such remedies, as are expressly warranted by the manufacturer of such parts or Goods. Notwithstanding the foregoing, any warranty with respect to such parts or Goods and any remedies available as a result of a breach thereof shall be subject to all of the procedures, limitations, and exclusions set forth herein.

THE WARRANTIES HEREIN ARE IN LIEU OF ALL WARRANTIES, EXPRESS, IMPLIED, STATUTORY, OR OTHERWISE. IN PARTICULAR, SCC MAKES NO WARRANTY OF MERCHANTABILITY OR FITNESS FOR A PARTICULAR PURPOSE.

No representative, agent or dealer of SCC has authority to modify, expand, or extend this Warranty, to waive any of the limitations or exclusions, or to make any different or additional warranties with respect to Goods.

Period of Limitations. No claim, suit or other proceeding may be brought by Purchaser for any breach of the foregoing warranty or this Agreement by SCC or in any way arising out of this Agreement or relating to the Goods after one year from the date of the breach. In the interpretation of this limitation on action for a breach by SCC, it is expressly agreed that there are no warranties of future performance of the goods that would extend that period of limitation herein contained for bringing an action.

Indemnifications. Purchaser agrees to indemnify, hold harmless, and defend SCC if so requested, from any and all liabilities, as defined herein, suffered, or incurred by SCC as a result of, or in connection with, any act, omission, or use of the Goods by Purchaser, its employees or customers, or any breach of this Agreement by Purchaser. Liabilities shall include all costs, claims, damages, judgments, and expenses (including reasonable attorney fees and costs).

Remedies of SCC. SCC's rights and remedies shall be cumulative and may be exercised from time to time. In a proceeding or action relating to the breach of this Agreement by Purchaser, Purchaser shall reimburse SCC for reasonable costs and attorney's fees incurred by SCC. No waiver by SCC of any breach of Purchaser shall be effective unless in writing nor operate as a waiver of any other breach of the same term thereafter. SCC shall not lose any right because it has not exercised it in the past.

Applicable Law. This Agreement is made in Michigan and shall be governed by and interpreted according to Michigan law. Any lawsuit arising out of this Agreement or the Goods may be handled by a federal or state court whose district includes Muskegon County, Michigan, and Purchaser consents that such court shall have personal jurisdiction over Purchaser.

Miscellaneous. If any provision of this Agreement is found to be invalid or unenforceable under any law, the provision shall be ineffective to that extent and for the duration of the illegality, but the remaining provisions shall be unaffected. Purchaser shall not assign any of its rights nor delegate any of its obligations under this Agreement without prior written consent of SCC. This Agreement shall be binding upon and inure to the benefit of SCC and Purchaser and each of their legal representatives, successors and assigns.

SCC warrants its products to be free of defects in materials and workmanship under normal use and service for a period of one (1) year from the date of delivery.

This warranty is extended only to the original purchaser for use of the Goods. It does not cover normal wear parts such as plastic tongs, tong holders, tong cables, bag holders, or acrylic dividers.

General Conditions. All service labor and/or parts charges are subject to approval by SCC. Contact the Customer Service Department in writing or call 231-798-8888.

All claims must contain the following information: (1) model & serial code number of equipment; (2) the date and place of installation; (3) the name and address of the agency which performed the installation; (4) the date of the equipment failure; and (5) a complete description of the equipment failure and all circumstances relating to that failure.

Once the claim has been determined to be a true warranty claim by SCC's Customer Service Department, the following procedure will be taken: (1) replacement parts will be sent at no charge from SCC on a freight prepaid basis; (2) reimbursement for service labor will be paid if the following conditions have been met - (a) prior approval of service agency was awarded from the Customer Service Department; and (b) an itemized statement of all labor charges incurred is received by the Customer Service Department. The cost of the service labor reimbursement will be based on straight time rates and reasonable time for the repair of the defect.

If problems occur with any compressor, notify SCC's Customer Service Department immediately. Any attempt to repair or alter the unit without prior consent from the Customer Service Department will render any warranty claim null and void. This warranty and protection plan does not apply to any condensing unit or any part thereof which has been subject to accident, negligence, misuse, or abuse, or which has not been operated in accordance with the manufacturer's recommendations or if the serial number of the unit has been altered, defaced, or removed.

One Year Limit of Liability. After SCC's one-year parts and labor warranty on the original F.O.B. unit has expired, SCC is not liable for either the equipment or labor costs of repairing or replacing the motor compressor, nor any other components that were included in the original F.O.B. unit.