

# GG SERIES GAS-FIRED TUBULAR UNIT HEATERS REPLACEMENT PARTS CATALOG

**INDEX**

UNIT NUMBER DESCRIPTION .....	2
GG-30/120 REPLACEMENT PARTS .....	3, 4, 5
OPTIONAL PARTS .....	6
CONVERSION KITS .....	7
WARRANTY INFORMATION .....	8

**IMPORTANT**  
WHEN ORDERING PARTS, PLEASE  
SPECIFY UNIT MODEL NO. AND SERIAL NO.



HVAC PRODUCTS

260 NORTH ELM ST. WESTFIELD, MA 01085

(413) 564-5540

[www.sterlinghvac.com](http://www.sterlinghvac.com)



# LOW PROFILE TUBULAR PROPELLER UNIT NUMBER DESCRIPTION

<b>Digit</b>	<b>G</b>	<b>X</b>	<b>X</b>	<b>X</b>	<b>-</b>	<b>1</b>	<b>2</b>	<b>3</b>	<b>4</b>	<b>5</b>	<b>6</b>	<b>7</b>	<b>8</b>	<b>9</b>	<b>10</b>	<b>11</b>	<b>12</b>	<b>13</b>	<b>14</b>	<b>15</b>	<b>+</b>
<b>Item</b>	<b>Prefix</b>					<b>UT</b>		<b>CA</b>			<b>FT</b>	<b>FM</b>	<b>GT</b>	<b>AL</b>	<b>GC</b>	<b>SV</b>	<b>MT</b>	<b>DL</b>	<b>AS</b>		

(Internal Use Only)

**Digit #1, 2 - Unit Type [UT]**

**GG** - Low Profile Tubular Propeller

**Digit #3, 4, 5 - Capacity [CA]**

**030** - 30,000 BTU/HR

**045** - 45,000 BTU/HR

**060** - 60,000 BTU/HR

**075** - 75,000 BTU/HR

**090** - 90,000 BTU/HR

**105** - 105,000 BTU/HR

**120** - 120,000 BTU/HR

**Digit #6 - Furnace Type [FT]**

**A** - Right Side Access

**Digit #7 - Furnace Material [FM]\***

**1** - Standard (Aluminized) Steel

**2** - 409 Stainless Steel

*\*Heat Exchanger Tube Material Only.*

**Digit #8 - Gas Type [GT]**

**N** - Natural Gas

**P** - Propane Gas (LP)

**Digit #9 - Altitude [AL]**

**S** - 0-4,999 ft.

**T** - 5,000-11,999 ft.

*Note: Installations over 2,000 ft. require gas input deration in the field. Refer to unit installation instructions.*

**Digit #10 - Direct Spark Gas Control [GC]**

**1** - Single Stage (Standard)

**2** - Two Stage (Capacities [CA] 060 through 120 only)

**Digit #11 - Supply Voltage [SV]**

**1** - 115/1/60      **5** - 230/3/60

**2** - 208/1/60      **6** - 460/3/60

**3** - 230/1/60      **7** - 575/3/60

**4** - 208/3/60      **Z** - Special

*Note: Supply Voltages [SV] 2-7 include field mounted step down transformer.*

**Digit #12 - Motor Type [MT]**

**1** - Open Drip Proof (Standard)

**2** - Totally Enclosed (Capacities [CA] 060 through 120 only)

**Digit #13 - Development Level [DL]**

**C** - Production Onset

**Digit #14+ - Accessories [AS]**

**FACTORY INSTALLED**

**S3** - 409 Stainless Steel Flue Collector

**Z1** - Special

**FIELD INSTALLED (11AS-\_\_\_\_\_)**

**All Field Installed Accessories are to be entered as a separate line item using catalog number which places "11AS" as a prefix. i.e. G3 becomes 11AS-G3.**

**A7** - High Pressure Regulator

**A7-1/2-1** Regulator for 0.5-10 PSI

**A7-3/8-1** Regulator for 10-20 PSI

**A7-5/16-1** Regulator for 20-35 PSI

**G1** - 1-Stage Mercury Free Thermostat (Round)

**G2** - 1-Stage Mercury Free Thermostat w/Guard Kit

**G3** - 1-Stage Mercury Free Thermostat w/Fan Switch

**G5** - 2-Stage Mercury Free Thermostat w/Fan Switch

**G6** - Locking Thermostat Cover

**G9** - 1-Stage Mercury Free Heating Only Thermostat

**GW** - WiFi Thermostat TH8321WF1001/U

**P5** - 24V SPST Relay-Specify Purpose

**T1** - Quick Swivel Mounting Bracket

**VC-4** - 4" Vent Cap

**X2** - 30 Degree Downturn Nozzle

**X3** - 60 Degree Downturn Nozzle

**X4** - 90 Degree Downturn Nozzle

**X7-4** - Combustion Air Inlet Kit (Capacities [CA] 030-075)

**X7-5** - Combustion Air Inlet Kit (Capacities [CA] 090-120)

# GG SERIES 30-120 MBH REPLACEMENT PARTS

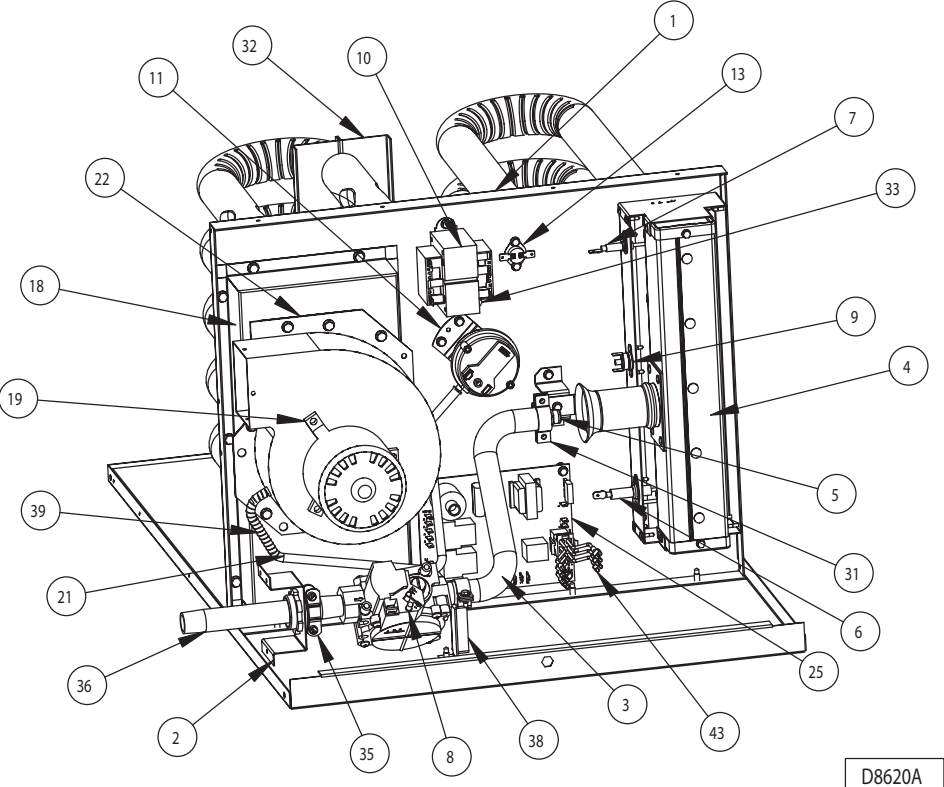
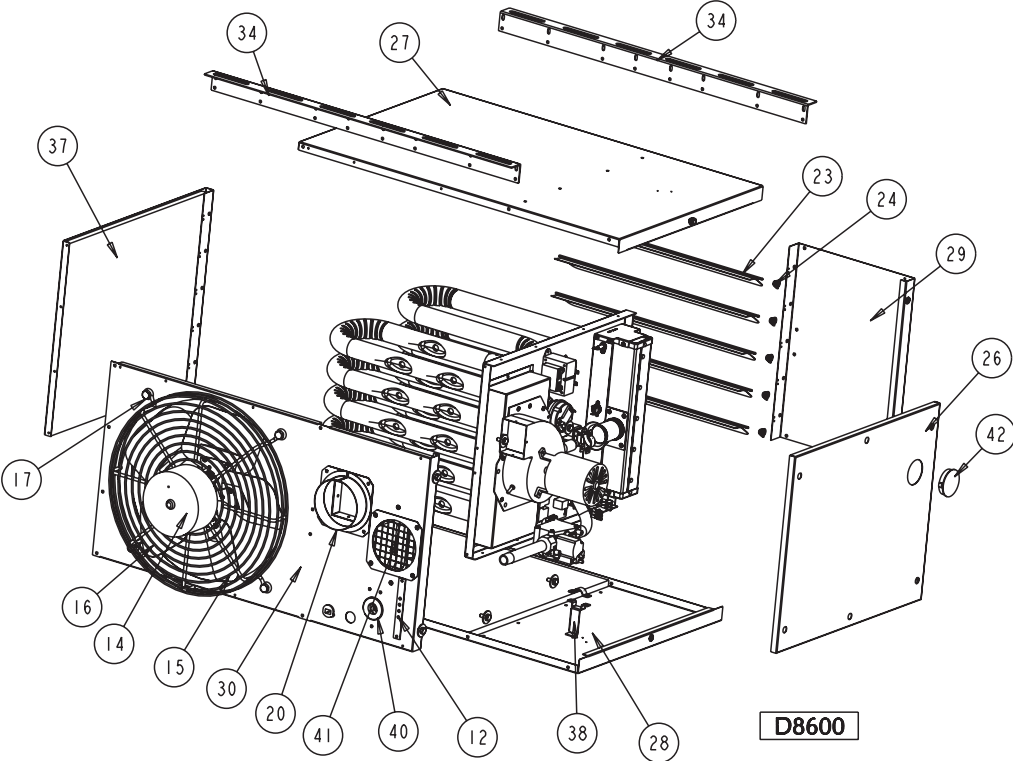

# GG SERIES 30-120 MBH REPLACEMENT PARTS

ITEM NO.	UNIT CAPACITY (MBH)		30	45
	NO. OF TUBES PER MODEL		2	3
ITEM DESCRIPTION		PART NO.		
1	VESTIBULE PANEL/TUBE ASS'Y (HEAT EXCHANGER)	ALUMINIZED	11501R08350-001	11501R08351-001
		409 STAINLESS STEEL	11501R08350-003	11501R08351-003
2	BRACKET/GAS TRAIN (REAR PANEL MOUNTED)	11252R08463		
3	MANIFOLD	11J37R08320-030		
4	BURNER ASSEMBLY (FLAME SENSOR, ROLLOUT SWITCH & IGNITOR SOLD SEPARATELY)	11502R08493-030	11502R08493-045	
5	BURNER ORIFICE [orifice size] QTY. REQUIRED FOR ALL MODEL SIZES = 1	NATURAL GAS	11J36R04694-018 [#38]	11J36R04694-023 [#31]
		PROPANE (LP) GAS	11512R08532-011 [#52]	11512R08532-012 [#48]
6	SPARK IGNITOR	11J38R06891-003		
7	FLAME SENSOR	11J38R06890-003		
8	GAS VALVE, SINGLE STAGE <sup>A</sup>	NATURAL GAS	11J28R06892-001	
		PROPANE (LP) GAS	11J28R06892-002	
9	MANUAL ROLLOUT SAFETY SWITCH	11J11R04849-003		
10	TRANSFORMER, 50 VA, 115/24	11J14R03245-012		
11	AIR PRESSURE SWITCH	STD ALT (0-4,999 FT)	11J11R06779-001	
		HIGH ALT (5,000 FT +)	11J11R06780-001	
12	TERMINAL BLOCK PLATE	11J09R04609		
13	HIGH LIMIT SWITCH	11J11R08365-002		
14	FAN MOTOR (ODP)	11J31R04766		
15	OSHA FAN GUARD	11J32R04884		
16	FAN BLADE	11J34R06999-016	11J34R06999-017	
17	FAN/GUARD/MOTOR MOUNT HARDWARE KIT	11261R04963-001		
18	FLUE COLLECTOR (INCLUDES GASKET) <sup>B</sup>	ALUMINIZED	11507R08312-130	11507R08312-145
		409 STAINLESS STEEL	11507R08312-330	11507R08312-345
19	POWER VENTER (DRAFTER) ASSEMBLY (INCLUDES GASKET)	11J35R04700		
20	FLUE COLLAR (INCLUDES GASKET AND HARDWARE)	11257R08337		
21	VINYL TUBING (PRESSURE SWITCH) - 19 INCHES LONG	11H07R01471-019		
22	POWER VENTER MOUNTING PLATE (INCLUDES GASKET)	NOT APPLICABLE		
23	LOUVER (QTY. REQ'D PER MODEL)	11257R04587-113 (3)		
24	LOUVER SPRING (QTY. REQ'D PER MODEL)	11J26R01960 (3)		
25	CONTROL BOARD	11J28R06881		
26	ACCESS PANEL (INCLUDES HARDWARE)	11251R08308-030		
27	TOP JACKET PANEL W/INSULATION	11251R08303		
28	BOTTOM JACKET PANEL W/INSULATION	11251R08303		
29	FRONT JACKET PANEL	11251R08306-030		
30	REAR JACKET PANEL	11251R08318-030		
31	BRACKET CAP, MANIFOLD	11252R08466		
32	TUBE SUPPORT BRACKET KIT	11252R06882	11252R06883	
33	GREEN GROUND SCREW	11J21R05120-001		
34	HANGER BRACKET	11252R08347		
35	MANIFOLD CLAMP	11J09R08500		
36	PIPE NIPPLE (6" LENGTH)	11J40R00601-010		
37	LEFT SIDE PANEL W/ INSULATION	11251R08345-030		
38	MANIFOLD SUPPORT BRACKET KIT	11252R08644		
39	SPRING (FOR VINYL TUBING)	11J26R06480		
40	GROMMET	11J07R02872-001		
41	INLET AIR COLLAR ASSEMBLY (INCLUDES SCREEN)	11257R10439		
42	BURNER BOX VIEW PORT	11J07R08348-001		
43	MOLEX CONNECTOR WIRE HARNESS ASSEMBLY	11J11R06887-001		
N/S	INLET AIR COLLAR GASKET	11262R08332		
N/S	ACCESS PANEL GASKET	11262R08614-004		
N/S	IGNITION CABLE (ORANGE) - 14 INCHES LONG	11J28R06971-001		
N/S	FLAME SENSOR WIRE (WHITE) - 21 INCHES LONG	11260R08248-001		

**Notes:**

- A When replacing single stage gas valve on units built between July 25, 2022 and November 18, 2022, gas valve bracket part no. 11252R08646 must also be ordered.
- B When replacing a flue collector, make sure the flue collector box is sealed completely with factory-supplied gasket.
- N/S Part not shown.

# GG SERIES 30-120 MBH REPLACEMENT PARTS

60	75	90	105	120	ITEM NO.
4	5	6	7	8	
PART NO.					
11501R08352-001	11501R08353-001	11501R08354-001	11501R08355-001	11501R08356-001	1
11501R08352-003	11501R08353-003	11501R08354-003	11501R08355-003	11501R08356-003	
11252R08463					2
11J37R08320-030		11J37R08320-190			3
11502R08493-060	11502R08493-075	11502R08493-090	11502R08493-105	11502R08493-120	4
11J36R04694-005 [#27]	11J36R04694-022 [#20]	11J36R04694-016 [#16]	11J36R04694-024 [#11]	11J36R04694-039 [#6]	5
11512R08532-008 [#43]	11512R08532-023 [#40]	11512R08532-009 [#36]	11512R08532-021 [#32]	11512R08532-022 [3.1MM]	
11J38R06891-003					6
11J38R06890-003					7
11J28R06892-001					8
11J28R06892-002					
11J11R04849-003					9
11J14R03245-012					10
11J11R06780-008		11J11R06780-004	11J11R06779-002		11
11J11R06780-009		11J11R06780-006	11J11R06780-002		
11J09R04609					12
11J11R08365-001					13
11J31R04091		11J31R04092-002			14
11J32R08327-002		11M32R06163			15
11J34R06999-006	11J34R06999-007	11J34R06999-114	11J34R06999-115	11J34R06999-103	16
11261R04963-002					17
11507R08312-160	11507R08312-175	11507R08311-190	11507R08311-105	SEE PAGE 7	18
11507R08312-360	11507R08312-375	11507R08311-390	11507R08311-305	SEE PAGE 7	
11J35R08510		11J35R04581			19
11257R08340					20
11H07R01471-019					21
NOT APPLICABLE		11252R08315			22
11257R04587-113 (5)		11257R04587-113 (7)			23
11J26R01960 (5)		11J26R01960 (7)			24
11J28R06881					25
11251R08308-060		11251R08308-090			26
11251R08303					27
11251R08303					28
11251R08306-060		11251R08306-090			29
11251R08318-060		11251R08318-090		SEE PAGE 7	30
11252R08466					31
11252R06884	11252R06885	11252R08364-090	11252R08364-105	11252R08364-120	32
11J21R05120-001					33
11252R08347					34
11J09R08500					35
11J40R00601-010					36
11251R08345-060		11251R08345-090			37
11252R08644					38
11J26R06480					39
11J07R02872-001					40
11257R10439		11251R10355			41
11J07R08348-001					42
11J11R06887-001					43
11262R08332		11J37R08335			N/S
11262R08614-004		11262R08614-005			N/S
11J28R06971-001					N/S
11260R08248-001					N/S

**Notes:**

- A When replacing single stage gas valve on units built between July 25, 2022 and November 18, 2022, gas valve bracket part no. 11252R08646 must also be ordered.
  - B When replacing a flue collector, make sure the flue collector box is sealed completely with factory-supplied gasket.
- N/S Part not shown.

# GG SERIES REPLACEMENT PARTS

FIELD INSTALLED AND OPTIONAL ITEMS		
DESCRIPTION [ACCESSORY OPTION NO.]		PART NO.
NATURAL GAS VALVE, TWO STAGE (UNIT SIZES 60-120)		11J28R06894-001
PROPANE (LP) GAS VALVE, TWO STAGE (UNIT SIZES 60-120)		11J28R06894-002
TOTALLY ENCLOSED FAN MOTOR (UNIT SIZES 60-75)		11J31R01872
TOTALLY ENCLOSED FAN MOTOR (UNIT SIZES 90-120)		11J31R01694
4" VENT CAP	[VC-4]	11AS-VC-4
4" TO 5" VENT ADAPTER (FOR 5" FLUE)		11J37R02185
TUBE OF HIGH TEMP SEALANT (2.8 oz.)		11H03R03612-002
TOUCH UP PAINT SPRAY CAN (12 oz.)		11512R01395-001
PRESSURE REGULATOR (0.5-10 PSI)		11AS-A7-1/2-1
PRESSURE REGULATOR (10-20 PSI)	[A7]	11AS-A7-3/8-1
PRESSURE REGULATOR (20-35 PSI)		11AS-A7-5/16-1
1-STAGE MERCURY-FREE THERMOSTAT (ROUND)	[G1]	11AS-G1
1-STAGE MERCURY-FREE THERMOSTAT W/ GUARD KIT	[G2]	11AS-G2
1-STAGE MERCURY-FREE THERMOSTAT W/ FAN SWITCH	[G3]	11AS-G3
2-STAGE MERCURY-FREE THERMOSTAT W/ FAN SWITCH	[G5]	11AS-G5
1-STAGE MERCURY-FREE THERMOSTAT, HEATING ONLY	[G9]	11AS-G9
WIFI THERMOSTAT TH8321WF1001/U	[GW]	11AS-GW
LOCKING THERMOSTAT COVER (GUARD)	[G6]	11AS-G6
24V SPST RELAY	[P5]	11J10R00818-003
QUICK SLING MOUNTING BRACKET	[T1]	11ASRT1

COMBUSTION AIR INLET KITS		
DESCRIPTION	4" (INCH) PART NO.	5" (INCH) PART NO.
COMPLETE KIT	11AS-X7-4	11AS-X7-5
<b>PARTS INCLUDED IN KIT (SOLD SEPARATELY)</b>		
VENT CAP (FLUE VENT TERMINAL)	11J37R08571-001	11J37R08571-002
COMBUSTION AIR INLET BOX ASSEMBLY	11507R06601-DBL	11507R08560-DBL
AIR INLET SCREEN	11J37R06665-DBL	11J37R08572-DBL
DEFLECTOR DISK	11507R06693-DBL	11507R08569-DBL
TUBE OF HIGH TEMP SEALANT (2.8 oz.)	11H03R03612-002	11H03R03612-002
GASKET, O-RING	11H03R09471-004	11H03R09471-005
FLUE VENT ADAPTOR - 5" TO 4"	N/A	11J37R02185

# GG SERIES GAS CONVERSION KITS

CONVERTING FROM NATURAL GAS (NG) TO PROPANE (LP) GAS		CONVERTING FROM PROPANE (LP) GAS TO NATURAL GAS (NG)	
MODEL NO.	CONVERSION KIT PART NO.	MODEL NO.	CONVERSION KIT PART NO.
GG-030	11CKNTPDS030-52	GG-030	11CKPTNDS030-38
GG-045	11CKNTPDS045-48	GG-045	11CKPTNDS045-31
GG-060	11CKNTPDS060-43	GG-060	11CKPTNDS060-27
GG-075	11CKNTPDS075-40	GG-075	11CKPTNDS075-20
GG-090	11CKNTPDS090-36	GG-090	11CKPTNDS090-16
GG-105	11CKNTPDS105-32	GG-105	11CKPTNDS105-11
GG-120	11CKNTPDS1203.1	GG-120	11CKPTNDS120-6

GG120 FLUE COLLECTOR AND REAR JACKET PANEL REPLACEMENT PARTS			
DESCRIPTION		GG120 MANUFACTURED <b>PRIOR</b> TO AUGUST 5, 2014	GG120 MANUFACTURED <b>ON OR</b> <b>AFTER</b> AUGUST 5, 2014
FLUE COLLECTOR	ALUMINIZED STEEL	11507R08311-120	11507R09478-120
	409 STAINLESS STEEL	11507R08311-320	11507R09478-320
AIR INLET BAFFLE		N/A	11507R08587
REAR JACKET PANEL		11251R08318-090	11251R09480-120

# IMPORTANT WARRANTY INFORMATION

If you are ordering a replacement part for a unit which you believe to be under warranty, the process is as follows:

- Provide Sterling with a description of the part or assembly needed and the model and serial number of the unit which experienced failure. If there is a question about the warranty, we can answer it at this point. Consultation with our Technical Service Dept. may be required to determine the correct replacement parts, and you will be given a call log number for reference.
- Fill out Sterling's Return Goods Authorization (RGA) Request Form, available on SalesAssistant.com. Submit the form to Sterling along with an order for the necessary parts. Be sure to include the call log number on both the form and the parts order.
- Once your order and completed RGA form are received, Sterling will enter the order and issue you an RGA, if applicable, with instructions on how and where to send the defective parts.
- An invoice will be generated and mailed. The invoice may list the call log number, RGA number and state "a RGA has been issued." Once the defective item has been returned and confirmed as "defective in warranty," a credit will be issued for the original invoice amount.
- Returned goods must ship back within 30 days from date of RGA. If we do not receive the parts within 30 days, the RGA will be voided. Parts returned and found to be valid under warranty will be credited for parts only. If our inspection reveals that the parts returned are in a non-warranty condition, no credit will be issued. Freight is not covered under warranty.

In order to ensure the orderly processing of your warranty claim, it is **MANDATORY** that certain paperwork accompany any and all goods returned to Sterling. It is also mandatory that goods be sent to the proper location.

In order to ensure proper handling of these goods, Sterling **MUST** formally authorize the return of material to our various facilities under any circumstance. Any material returned without authorization will not be accepted.

In order to ensure that your properly authorized returns are accepted at our plant, you **MUST** clearly mark any and all shipping papers with an RGA number; Sterling will not accept shipments that do not clearly show an RGA number on the outside of the box or crate!

**All returns to be shipped Freight Prepaid.  
Collect Shipments will not be accepted.**

CONSULT OUR CUSTOMER SERVICE DEPT. FOR ANY  
REPLACEMENT PARTS NOT LISTED IN THIS PUBLICATION.  
LIMITED AVAILABILITY ON CERTAIN OBSOLETE EQUIPMENT.

TEL. 413-564-5540

FAX# 413-562-5311

[www.sterlinghvac.com](http://www.sterlinghvac.com)

## LIMITED WARRANTY

The product described in this catalog are warranted by Sterling, A Mestek Co. to be free from defects in material and workmanship for a period of one (1) year from the date of shipment from Sterling's plant.

Sterling will repair or replace, at its option, any components which, upon inspection, it finds to be defective, provided that the unit has been operated within its listed capacity, has been installed in accordance with the furnished instructions, has not been misused or subject to negligence and has received reasonable and necessary maintenance. This warranty does not cover labor costs or other cost incurred in repairing, removing, installing, servicing or handling of parts or complete products.

Sterling will in no event be liable for incidental or consequential damages of any kind whatsoever.

The buyer must request written permission from Sterling to return defective components and then must send them with all transportation charges prepaid to the plant designated in the written permission.

This warranty is extended only to the original purchaser from Sterling.



260 NORTH ELM ST. WESTFIELD, MA 01085  
(413) 564-5540  
[www.sterlinghvac.com](http://www.sterlinghvac.com)

