



**Model U431I2**  
**OPERATORS MANUAL**

Manual No. 513660

Rev.2



This manual provides basic information about the machine. Instructions and suggestions are given covering its operation and care.

The illustrations and specifications are not binding in detail. We reserve the right to make changes to the machine without notice, and without incurring any obligation to modify or provide new parts for machines built prior to date of change.

**DO NOT ATTEMPT** to operate the machine until instructions and safety precautions in this manual are read completely and are thoroughly understood. If problems develop or questions arise in connection with installation, operation, or servicing of the machine, contact Stoelting.



[stoeltingfoodservice.com](http://stoeltingfoodservice.com)

Stoelting Foodservice Equipment  
502 Highway 67  
Kiel, WI 53042-1600  
U.S.A.

Main Tel: 800.558.5807  
Fax: 920.894.7029

Customer Service: 888.429.5920  
Fax: 800.545.0662  
Email: [foodservice@stoelting.com](mailto:foodservice@stoelting.com)

© 2014 PW Stoelting, LLC

---

## ***A Few Words About Safety***

### **Safety Information**

**Read and understand the entire manual before operating or maintaining Stoelting equipment.**

This manual provides the operator with information for the safe operation and maintenance of Stoelting equipment. As with any machine, there are hazards associated with their operation. For this reason safety is emphasized throughout the manual. To highlight specific safety information, the following safety definitions are provided to assist the reader.

The purpose of safety symbols is to attract your attention to possible dangers. The safety symbols, and their explanations, deserve your careful attention and understanding. The safety warnings do not by themselves eliminate any danger. The instructions or warnings they give are not substitutes for proper accident prevention measures.

If you need to replace a part, use genuine Stoelting parts with the correct part number or an equivalent part. We strongly recommend that you do not use replacement parts of inferior quality.



### **Safety Alert Symbol:**

**This symbol** Indicates danger, warning or caution. Attention is required in order to avoid serious personal injury. The message that follows the symbol contains important information about safety.

### **Signal Word:**

Signal words are distinctive words used throughout this manual that alert the reader to the existence and relative degree of a hazard.



The signal word “WARNING” indicates a potentially hazardous situation, which, if not avoided, may result in death or serious injury and equipment/property damage.



The signal word “CAUTION” indicates a potentially hazardous situation, which, if not avoided, may result in minor or moderate injury and equipment/property damage.

### **CAUTION**

The signal word “CAUTION” not preceded by the safety alert symbol indicates a potentially hazardous situation, which, if not avoided, may result in equipment/property damage.

### **NOTE (or NOTICE)**

The signal word “NOTICE” indicates information or procedures that relate directly or indirectly to the safety of personnel or equipment/property.

# TABLE OF CONTENTS

Section	Description	Page
<b>1</b>	<b>Description and Specifications</b>	
1.1	Description.....	1
1.2	Specifications .....	2
<b>2</b>	<b>Installation Instructions</b>	
2.1	Safety Precautions .....	3
2.2	Shipment and Transit.....	3
2.3	Machine Installation.....	3
2.4	Installing Wiring .....	3
2.5	Mix Pump.....	4
A.	Mix Pump Hose Installation.....	4
B.	Mix Pickup Hose Installation .....	4
C.	Mix Low Level Indicator Adjustment.....	6
2.6	IntelliTec2™ Setup.....	6
<b>3</b>	<b>Initial Set-Up and Operation</b>	
3.1	Operator's Safety Precautions .....	9
3.2	Operating Controls and Indicators.....	9
3.3	Disassembly of Parts.....	10
3.4	Cleaning Disassembled Parts .....	11
A.	Remove Front Door.....	11
B.	Remove Auger .....	11
3.5	Sanitizing Parts.....	11
3.6	Cleaning the Machine.....	11
3.7	Assembling the Machine .....	12
3.8	Sanitizing .....	13
3.9	Freeze Down and Operation .....	13
3.10	Mix Information .....	14
3.11	Operation of Mix Pump.....	14
3.12	Mix Pump Cleaning .....	15

<b>Section</b>	<b>Description</b>	<b>Page</b>
<b>4</b>	<b>Maintenance and Adjustments</b>	
4.1	Overrun Adjustment.....	17
4.2	Mix Pump Hose Reposition .....	17
4.3	Mix Pump Hose Replacement .....	18
4.4	Fine Consistency Adjustment .....	19
4.5	Drive Belt Tension Adjustment.....	19
4.6	Condenser Cleaning (Air-Cooled Machines) .....	19
4.7	Preventative Maintenance .....	19
4.8	Extended Storage .....	19
<b>5</b>	<b>Troubleshooting</b>	
5.1	Error Codes .....	21
5.2	Troubleshooting - Error Codes .....	21
5.3	Troubleshooting - Machine .....	23
5.4	Troubleshooting - Mix Pump.....	24
<b>6</b>	<b>Replacement Parts</b>	
6.1	Brushes, Decals and Lubrication.....	27
6.2	Trays.....	27
6.3	Auger Shaft and Front Door Parts .....	28
6.4	Cab Tubing .....	29

# SECTION 1 DESCRIPTION AND SPECIFICATIONS

## 1.1 DESCRIPTION

The Stoelting U431 I2 floor model machine is pressure fed. It is equipped with fully automatic controls to provide a uniform product.

This manual is designed to assist qualified service personnel and operators with installation, operation and maintenance of the U431 I2.



Figure 1-1 Model U431 I2 Machine

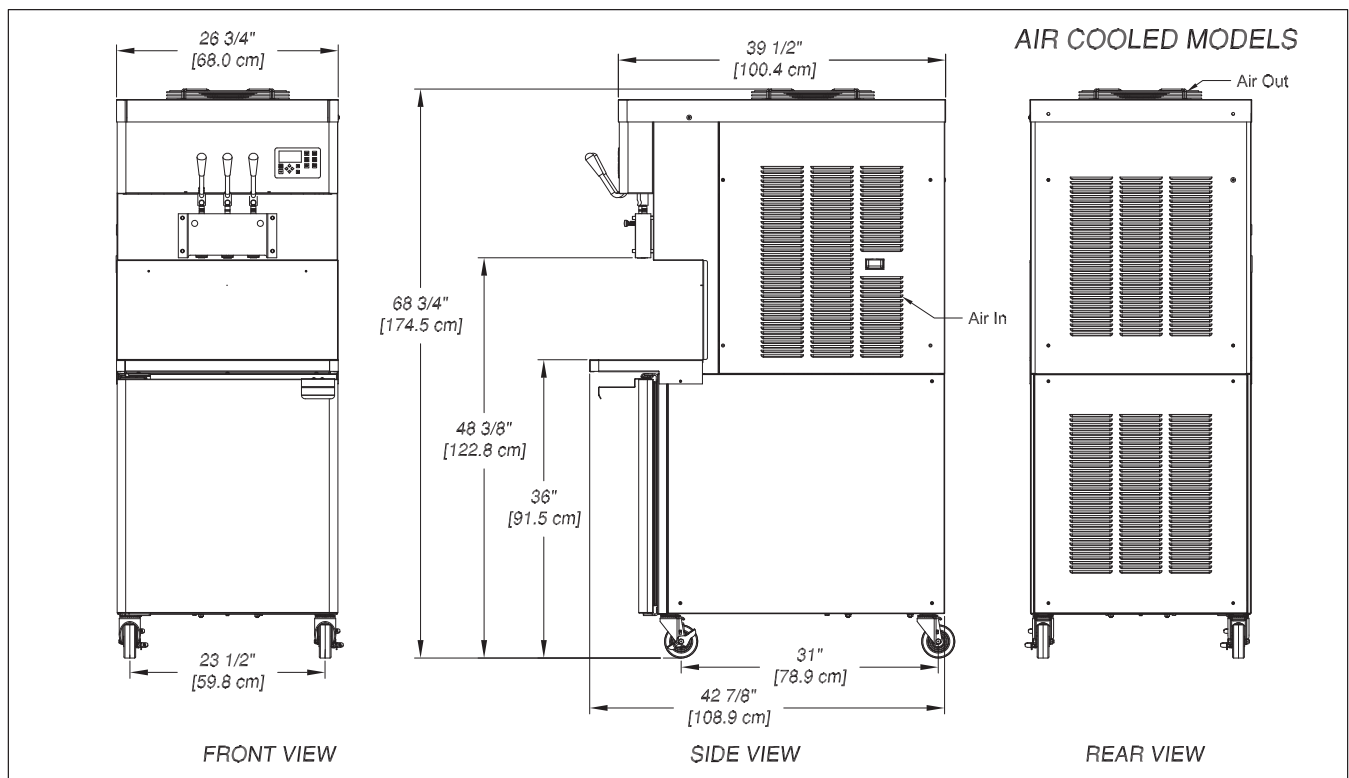

Figure 1-2 Dimensions

## 1.2 SPECIFICATIONS

	U431-I2 Water Cooled				U431-I2 Air Cooled			
Dimensions	Machine		with crate		Machine		with crate	
	width	26-3/4" (67,9 cm)		34" (86,4 cm)		26-3/4" (67,9 cm)		34" (86,4 cm)
height	67-1/2" (171,5 cm)		78" (198,1 cm)		68-3/4" (174,6 cm)		78" (198,1 cm)	
depth	39-1/2" (100,3 cm)		48" (121,9 cm)		39-1/2" (100,3 cm)		48" (121,9 cm)	
Weight	760 lbs (344,7 kg)		908 lbs (411,8 kg)		785 lbs (356,0 kg)		935 lbs (424,1 kg)	
Electrical	1 PH		3 PH		1 PH		3 PH	
	left	right	left	right	left	right	left	right
minimum circuit ampacity	32A	32A	20A	20A	32A	32A	20A	20A
maximum overcurrent protection device	50A	50A	30A	30A	50A	50A	30A	30A
International Option	1 Phase, 220-240 VAC, 50Hz or 3 Phase, 380-415 VAC, 50Hz							
Compressor	Two - 19,000 Btu/hr Cabinet - 1,300 Btu/hr Compressor (R-134a)							
Drive Motor	Two - 2 hp							
Cooling	Water cooled units require 1/2" N.P.T. water and drain fittings. Maximum water pressure of 130 psi. Minimum water flow rate of 3 GPM per barrel. Ideal EWT of 50°-70°F. The machine requires 6" (15,2 cm) air space on all sides for the cabinet refrigeration system.				Air cooled units require 6" (15,2 cm) air space on all sides and open at the top.			
Hopper Volume	Two - 8 gallon (30,28 liters)							
Freezing Cylinder Volume	Two - 1.33 gallon (5,03 liters)							



## SECTION 2 INSTALLATION INSTRUCTIONS

### 2.1 SAFETY PRECAUTIONS

Do not attempt to operate the machine until the safety precautions and operating instructions in this manual are read completely and are thoroughly understood.

Take notice of all warning labels on the machine. The labels have been put there to help maintain a safe working environment. The labels have been designed to withstand washing and cleaning. All labels must remain legible for the life of the machine. Labels should be checked periodically to be sure they can be recognized as warning labels.

If danger, warning or caution labels are needed, indicate the part number, type of label, location of label, and quantity required along with your address and mail to:

**STOELTING**  
**ATTENTION: Customer Service**  
**502 Hwy. 67**  
**Kiel, Wisconsin 53042**

### 2.2 SHIPMENT AND TRANSIT

The machine has been assembled, operated and inspected at the factory. Upon arrival at the final destination, the entire machine must be checked for any damage which may have occurred during transit.

With the method of packaging used, the machine should arrive in excellent condition. THE CARRIER IS RESPONSIBLE FOR ALL DAMAGE IN TRANSIT, WHETHER VISIBLE OR CONCEALED. Do not pay the freight bill until the machine has been checked for damage. Have the carrier note any visible damage on the freight bill. If concealed damage and/or shortage is found later, advise the carrier within 10 days and request inspection. The customer must place a claim for damages and/or shortages in shipment with the carrier. Stoelting, Inc. cannot make any claims against the carrier.

### 2.3 MACHINE INSTALLATION



#### WARNING

**Installation must be completed by a qualified electrician/refrigeration specialist.**

Incorrect installation may cause personal injury, severe damage to the machine and will void factory warranty.

Installation of the machine involves moving the machine close to its permanent location, removing all crating, setting in place, assembling parts, and cleaning.

### PRIOR TO INSTALLATION

- A. Locate a copy of the service contact file (info.txt).
- B. Modify the info.txt file with information from the service company using the instructions in the file.
- C. Put the service contact file onto the root level of a USB flash drive (do not put the files into any folder).

### INSTALLATION

- A. Uncrate the machine.
- B. Install the four casters. Turn the threaded end into the machine until no threads are showing. To level, turn out casters no more than 1/4" maximum, then tighten all jam nuts.
- C. The machine must be placed in a solid level position.

#### NOTE

*Accurate leveling is necessary for correct drainage of freezing cylinder and to insure correct overrun.*

- D. Machines with air cooled condensers require a minimum of 6" (15,2cm) space on all sides and back for proper circulation.

#### NOTE

*In order for the condenser fan motor to work the left side needs to be connected to a power source.*

- E. In air-cooled machines, use a voltmeter to measure incoming voltage. If the supply voltage is 215 or less, remove the right side panel and move the voltage selector toggle switch to the 208V position.

#### NOTE

*Supply voltage must be checked to make sure the fan motor operates properly.*

- F. Machines that have a water cooled condenser require 1/2" NPT supply and drain fittings.

### 2.4 INSTALLING WIRING

- A. Refer to the nameplate on the side panel of the machine for specific electrical requirements. Make sure the power source in the building matches the nameplate requirements. Bring the wires into the junction boxes through the access holes in the bottom rear of the freezer.

#### NOTE

*Three phase freezers in areas of unbalanced electrical loads require special attention when connecting input electrical power. The unbalanced leg of power (called wild or high) must be connected to L2 in the junction box.*

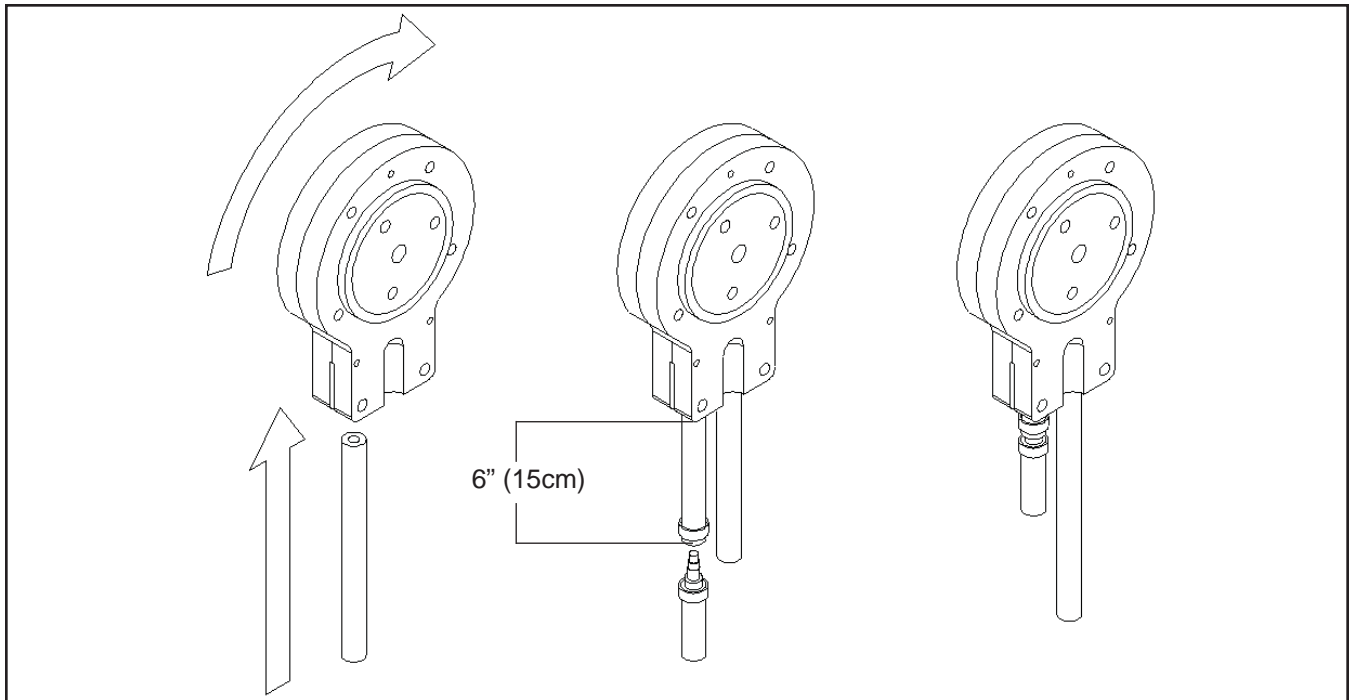

**Figure 2-2 Mix Hose Installation**

- B. Remove the back panel and the junction box cover located at the bottom of the machine.
  - C. Install permanent wiring according to local code.
  - D. Check the auger shaft rotation by pressing the Main Power On/Off button and pressing the On/Off Left or On/Off Right button. The Motor Calibration screen will be displayed.
  - E. Move the cursor over the Left side and press the SEL button then move the cursor over the Right side and press the SEL button.
  - F. Auger shaft rotation is clockwise as viewed through the clear front door.
  - G. Press the left arrow button to stop the augers after checking the rotation.
2. Feed one end of the mix pump hose into the entering or pickup hose side (left) of black cover (Fig 2-2).

**NOTE**

*Feed the tube into the clamp so the natural curve of the tube is towards the outside of the black cover. This prevents the hose from looping around the black cover twice.*

3. Gently push the hose into the black cover until it begins to feed.
4. Allow the hose to feed itself through the pump until about 6" (15cm) remains on the entering side.
5. Turn the pump off.
6. Connect the mix pump hose to the elbow fitting (located on the left side of the mix line manifold) using a small hose clamp. Be careful not to twist the mix hose.
7. Turn the pump on.
8. Allow the remaining 6" (15cm) of tubing to feed through pump until the hose adapter prevents further feeding.
9. Turn the pump off.

**NOTE**

*Press the left arrow button to exit the calibration before the 5 minute timer expires. Motor calibration will be completed in Section 2.6 and must be done with sanitizer in the freezing cylinders.*

**2.5 MIX PUMP**

**A. MIX PUMP HOSE INSTALLATION**

Follow the steps below to install the mix pump hose in the cabinet part of the machine.

1. Turn the mix pump on by pressing the Pump On/Off button on the touchpad.

**CAUTION**

**Risk of Product Damage**

Air/Mix Tee must remain below the black cover clamp. If the Tee is above the pump, mix may drain into the air compressor resulting in pump damage.

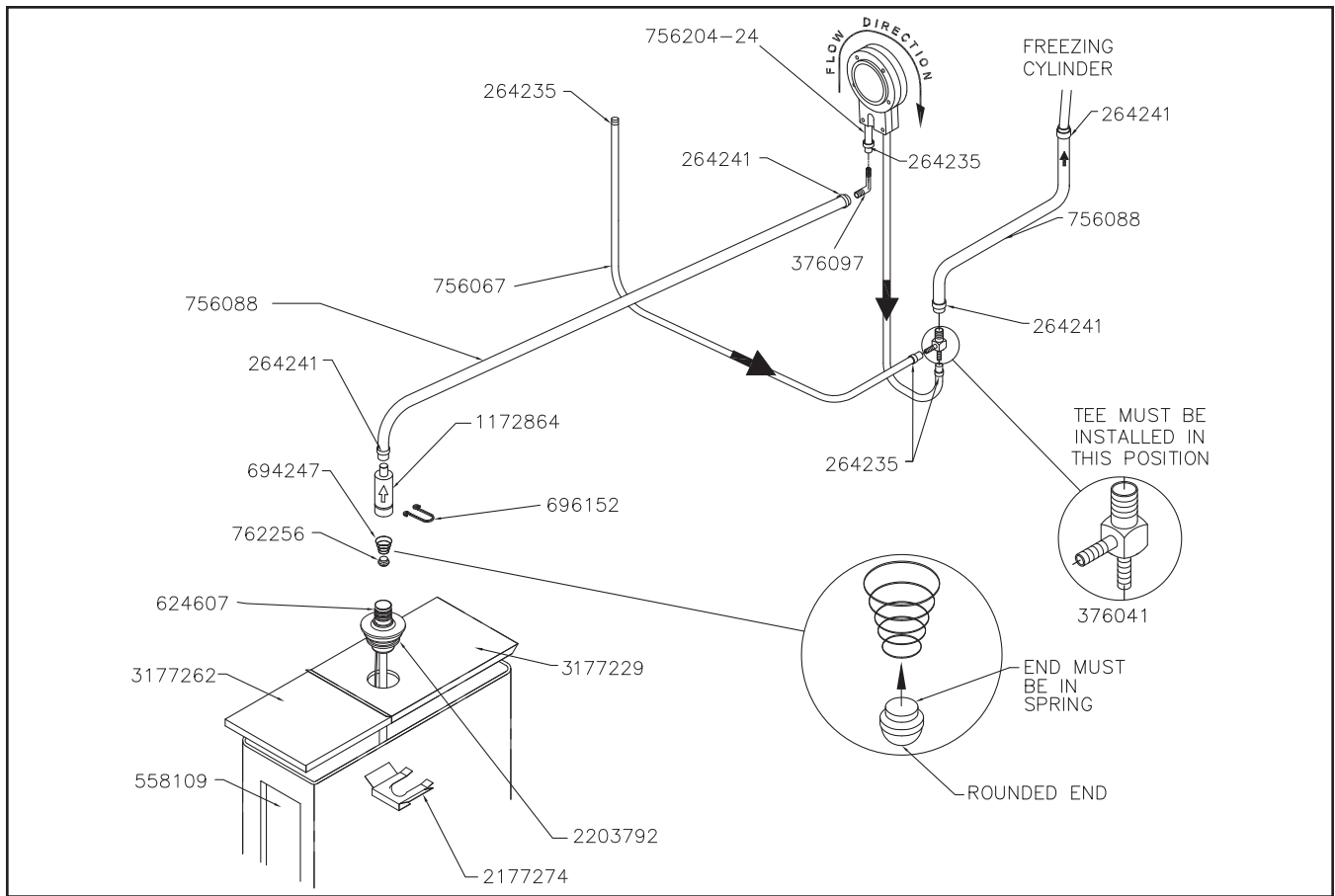

**Figure 2-3 Mix Pump Connections for Standard Mix Container**

10. Connect the free end of the mix pump hose to the 3-way Tee (Fig. 2-3). When all connections are complete, the 3-way Tee must be lower than the black pump housing.

**B. MIX PICKUP HOSE INSTALLATION**

The machine may be connected to the standard mix container or up to three prepacked mix bags. Follow the instructions below that match your configuration.

**Standard Connection:**

1. Place the mix pickup assembly through the hole in the cover and install the retaining clip.
2. Connect a 24" (61cm) length of 3/8" (9,5mm) ID plastic food grade tubing to the mix pickup assembly and secure with a hose clamp.
3. Connect the elbow fitting to the free end of the tubing. Connect the opposite end of the elbow to 1/4" ID tan tubing on the left side of the pump head. Secure with hose clamps (Fig. 2-3).

**When Using Bag Connection System (BCS) with Three Bags (optional kit #2183987):**

The position of the three bags in the mix container is important. The bag that is connected nearest the outlet of the manifold will drain last and should be placed at the back of the mix container. The mix low level indicator relies on proper bag placement.

1. Connect 3/8" (9,5mm) ID plastic food grade tubing to a bag adapter. Secure with hose clamps.
2. Slide the hose clip over free end of 3/8" (9,5mm) ID plastic food grade tubing. Attach the free end of the tubing to a manifold adapter. Secure with a large hose clamp or equivalent.
3. Push the manifold adapter with spring and valve into the left port (nearest the manifold outlet) of the mix inlet manifold and secure with a retaining clip. (Fig. 2-4).
4. Repeat steps 1 to 3 for the middle port and for the right port of the mix inlet manifold.
5. Place three mix bags into the mix container.
6. Connect the bag adapter attached to the left side of the manifold (closest to the mix outlet) to the mix bag in the back of the mix container.
7. Connect the bag adapter attached to the middle of the manifold to the mix bag in the middle of the mix container.
8. Connect the bag adapter attached to the right side of the manifold (farthest from the mix outlet) to the mix bag in the front of the mix container.

### When Using Bag Connection System (BCS) with One or Two Bags (optional kit #2183987):

When connecting one or two bags, the manifold adapters must be installed closest to the manifold outlet and the manifold plug(s) must be placed farthest from the manifold outlet.

1. Connect 3/8" (9,5mm) ID plastic food grade tubing to a bag adapter. Secure with hose clamps.
2. Slide the hose clip over the free end of the tubing. Attach the free end of the tubing to a manifold adapter. Secure with a large hose clamp.
3. Push the manifold adapter with spring and valve into the left port (nearest the manifold outlet) of the mix inlet manifold and secure with retaining clip. (See Figure 2-4).
4. If using two mix bags, repeat steps 1 to 3 for the middle port.
5. Install a manifold plug into each empty inlet and secure with a retaining clip.
6. Place the mix bag(s) into the mix container.
7. Connect the bag adapter attached to the left side of the manifold (closest to the mix outlet) to the mix bag in the back of the mix container.

### 2.6 INTELLITEC2™ SETUP

- A. Disassemble, clean, lubricate and assemble the machine following the steps in Section 3.
- B. Fill the mix containers in the cabinet with sanitizer.
- C. Connect power to the machine and press the Main Power On/Off button.

#### NOTE

*The Current Status screen should show "Calibration Required" for both cylinders. If it does not, go to the Unit Calibration option in the Utilities menu to complete the calibration.*

- D. Press the Pump On/Off button when the Current Status screen is displayed.

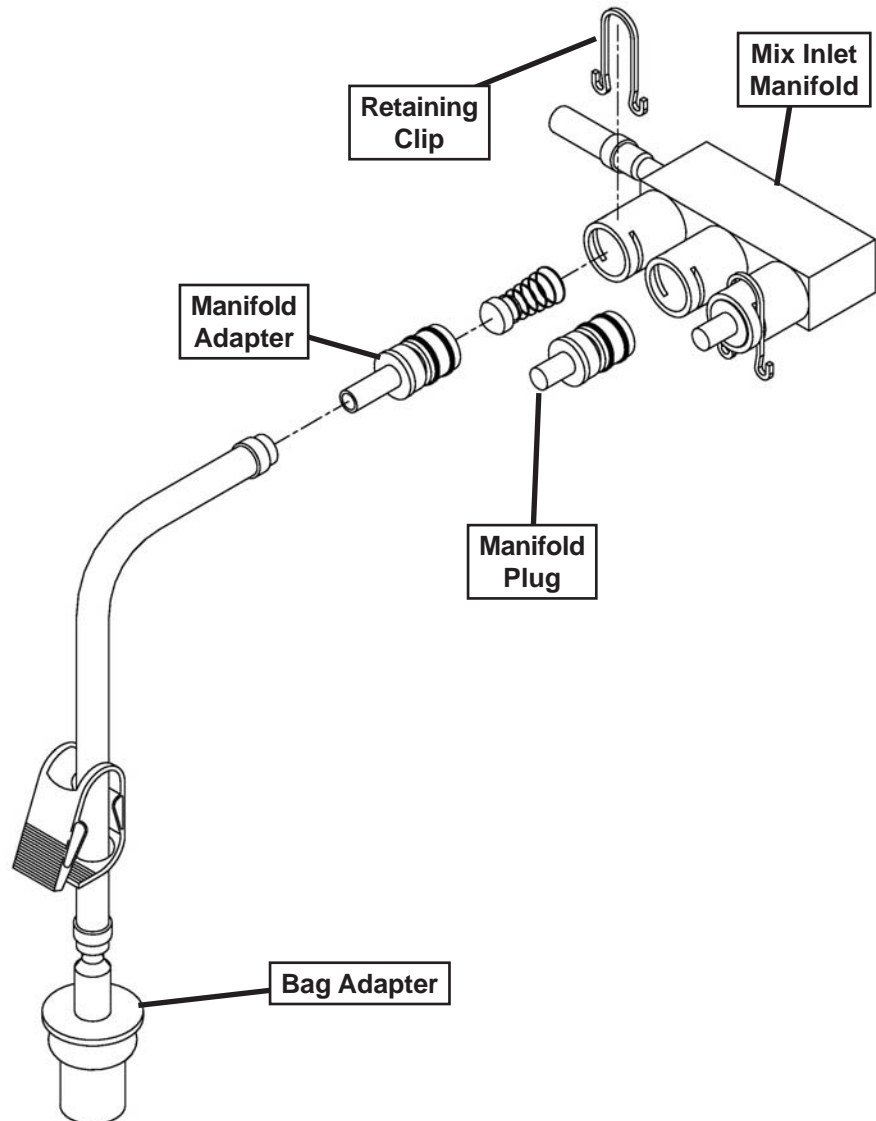
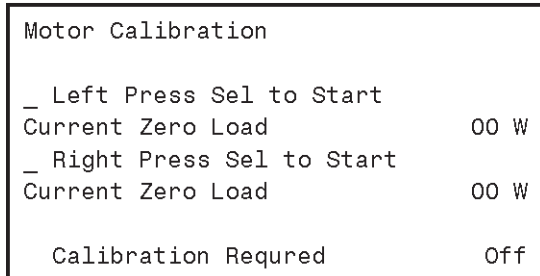

Figure 2-4 Bag Connection System (Optional)

## MOTOR CALIBRATION

Before starting the motor calibration, be sure there is sanitizer in the freezing cylinder.

- A. Press the On/Off Left or On/Off Right button. The Motor Calibration screen will be displayed.



**Figure 2-5**

- B. Move the cursor over the Left side and press the SEL button then move the cursor over the Right side and press the SEL button.

### NOTE

*The motor calibration can be done for both sides simultaneously.*

- C. After the calibration is complete, press the left arrow button.  
 D. Drain the machine of sanitizer.  
 E. Press the Pump On/Off button.

## SETTING CONTACT INFORMATION

- A. Plug your USB flash drive into the control if it is not already plugged in.  
 B. From the Current Status screen, press the left arrow button to access the passcode selection screen. Press the right arrow, SET, and then the SEL button.  
 C. After the password is accepted, use the arrows to move the cursor to the Modify Settings option and press the SEL button. Then move the cursor to the User Preferences and press the SEL button.

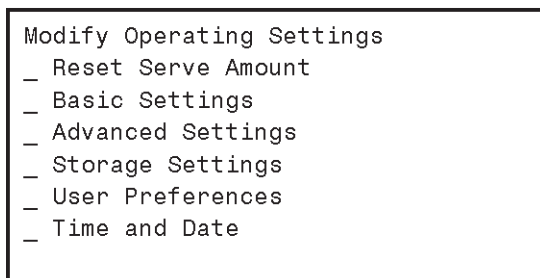

**Figure 2-6**

- D. On the User Preferences screen move the cursor to the Contact Information USB Update and press the SEL button.

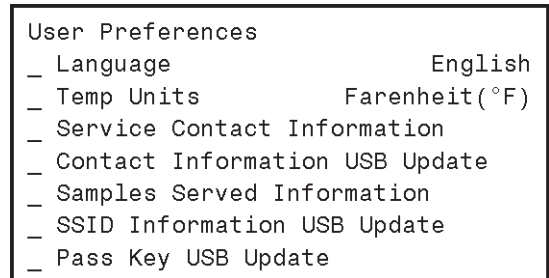

**Figure 2-7**

- E. The screen will change and show "File Found" for a quick second while it updates the information.  
 F. After updating the contact information, the screen will show the Service Contact Information page.

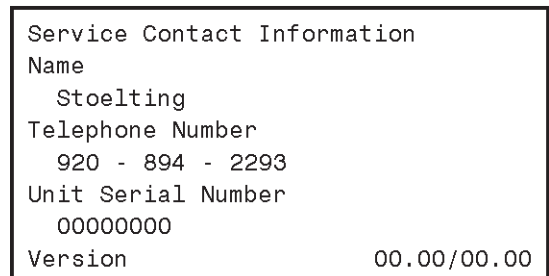
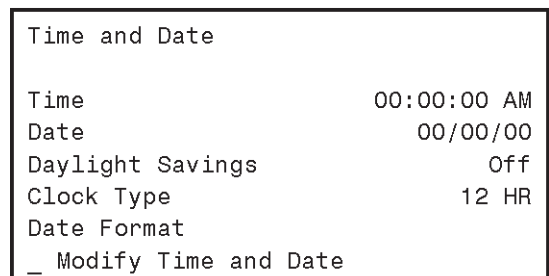

**Figure 2-8**

- G. Press the left arrow button to go back to the Current Status screen and remove the USB flash drive.

## SETTING TIME AND DATE

- A. Press the right arrow button.  
 B. Move the cursor to the Modify Settings option and press the SEL button. Then move the cursor to the Time and Date option and press the SEL button and adjust the settings as required.
  1. Press the SEL button to enter the Modify Time and Date screen.
  2. Move the cursor to the setting that needs to be changed and press the SET button.
  3. Use the arrow buttons to change the setting and press the SET button to save the change.



**Figure 2-9**

- C. Press the left arrow button until the Current Status screen is displayed.

## SETTING CONSISTENCY

- A. Fill the mix container with liquid mix.
- B. Press the Pump On/Off button. Prime the freezing cylinder. After the pump button is pressed, mix will partially fill the freezing cylinder and the pump will cycle off. After the pump turns off, press the air bleed valve on the front door to prime the freezing cylinder. Release the valve and pull outwards. Make sure the mix level in the freezing cylinder is above the hub on the auger shaft.
- C. Press the Push to Freeze button and let the machine cycle 4-5 times.
- D. Draw product from the barrel immediately after the compressor cycles off after the fifth time and test the product for consistency and temperature.
- E. Adjust the product consistency by increasing or decreasing the Consist Offset settings. These settings are under the Modify Settings Basic Settings menu
- F. If the machine short cycles (short on/off compressor run times), change the settings as follows:
  1. If the product is too soft, increase the CutIn Consist Offset.
  2. If the product is too firm, decrease the CutIn Consist Offset.
- F. After the consistency is set, press the left arrow button once so that the Modify Operating Settings screen is displayed.

## SETTING SERVE TIME AND OVERRUN DETAILS

- A. Go to the Advanced Settings (2 of 3) screen and scroll down to the Time to Dispense 16 oz option.
- B. Time how long it takes to dispense 16 oz of product into a cup and change the value in the control.
- C. Measure to overrun of the product and change the value in the control. To measure overrun, do the following:
  1. Zero a scale with an 8 - 16 oz cup.
  2. Fill the cup with liquid mix and weigh it. Make sure the mix is filled to the rim.
  3. Fill the cup with frozen product.
  4. Scrape the top of the cup with a straight edge.
  5. Weigh the filled cup.
  6. Calculate the overrun using the following equation:  
$$\frac{\text{Liquid Weight} - \text{Frozen Weight}}{\text{Frozen Weight}} \times 100 = \% \text{ Overrun}$$
- D. Change the value in the control.
- E. Press the left arrow button until the Current Status screen is displayed.

## SETTING DISCHARGE PRESSURE ON WATER COOLED MACHINES

- A. Water cooled machines require the water condenser valves to be adjusted to maintain a 235-240 psig discharge pressure.  
  
When adjusting the discharge pressure the machine must be under a full load with both cylinders running.



## SECTION 3 INITIAL SET-UP AND OPERATION

### 3.1 OPERATOR'S SAFETY PRECAUTIONS

SAFE OPERATION IS NO ACCIDENT; observe these rules:

- A. Know the machine. Read and understand the Operating Instructions.
- B. Notice all warning labels on the machine.
- C. Wear proper clothing. Avoid loose fitting garments, and remove watches, rings or jewelry that could cause a serious accident.
- D. Maintain a clean work area. Avoid accidents by cleaning up the area and keeping it clean.
- E. Stay alert at all times. Know which switch, push button or control you are about to use and what effect it is going to have.
- F. Disconnect power for maintenance. Never attempt to repair or perform maintenance on the machine until the main electrical power has been disconnected.
- G. Do not operate under unsafe operating conditions. Never operate the machine if unusual or excessive noise or vibration occurs.

### 3.2 OPERATING CONTROLS AND INDICATORS

Before operating the machine, it is required that the operator know the function of each operating control. Refer to Figure 3-1 for the location of the operating controls on the machine. For the information regarding error codes displayed on the control panel, refer to the troubleshooting section of this manual.

#### **WARNING**

High voltage will shock, burn or cause death. Make sure the display shows the freezing cylinders and pump are off. If they are not, press the On/Off button and Pump button to turn them off prior to disassembling for cleaning or servicing. Do not operate machine with panels removed.



**Figure 3-1 U431 I2 Machine Controls**

## A. INTELLITEC2™ TOUCHPAD

### Main Power On/Off

The Main Power button is used to supply power to the IntelliTec2™ control, the freezing cylinder circuits and the storage refrigeration system. When the machine is first plugged in, the control defaults to the On status with power to the cabinet only. If the Main Power On/Off button is pressed when the machine is on, the machine will turn off and a status message will be displayed on the screen.

### Help

Pressing the Help button will display help information dependant on the cursor's location. Pressing the Help button again will exit the help screen.

### Selection Button (SEL)

The SEL button is used by service technicians to select menu options.

### Set Button (SET)

The SET button is used by service technicians to save changes when modifying control settings.

### On/Off Button

Power to the freezing cylinders can then be controlled with the On/Off Left and On/Off Right buttons.

### Push to Freeze Button

Pressing the PUSH TO FREEZE button initiates "Serve Mode".

### Clean Button

The CLEAN button initiates "Clean Mode".

### Pump Button

The PUMP On/Off buttons control power to the pump.

### NOTE

*If the setting for the pump is automatic, the Pump On/Off buttons will not operate the pump and the display will show the pumps set to automatic.*

### Arrow Buttons (←, ↑, →, ↓)

The arrow buttons are used by service technicians to navigate through the control readings and settings.

## B. SPIGOT SWITCH

The spigot switch is mounted to the spigot cam assembly behind the header panel. When the spigot is opened to dispense product, the spigot switch opens and the "Serve Mode" begins.

## C. DISPENSE RATE ADJUSTOR

The dispense rate adjustor is located under the header panel, to the immediate right of the spigot handles. Turning the knob counterclockwise will decrease the dispense rate.

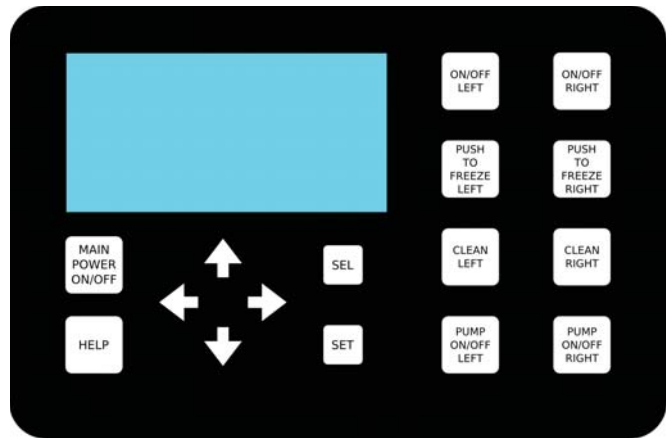

Figure 3-2 IntelliTec2™ Control

## 3.3 DISASSEMBLY OF PARTS

Before using the machine for the first time, complete machine disassembly, cleaning and sanitizing procedures need to be followed. Routine cleaning intervals and procedures must comply with the local and state health codes. Inspection for worn or broken parts should be made at every disassembly of the machine. All worn or broken parts should be replaced to ensure safety to both the operator and the customer and to maintain good machine performance and a quality product. Check the wear line on the auger flights on a regular basis (Fig. 3-3) and replace as needed. Frequency of cleaning must comply with the local health regulations.



Figure 3-3 Auger Flight Wear

To disassemble the machine, refer to the following steps:

### A. REMOVE FRONT DOOR

1. Remove the knobs on the front door and remove the door by pulling it off the studs.
2. Remove the air bleed valve by unscrewing the knob while holding the valve stem from behind. Remove the compression spring and push the air bleed valve through the rear of the front door.





**Figure 3-4 Removing O-Ring**

3. Remove the spigots through the bottom of the front door.
4. Remove all o-rings from parts by first wiping off the lubrication using a clean towel. Then squeeze the o-ring upward to form a loop (Fig. 3-4). Roll the o-ring out of the groove.

**CAUTION**

Do not use any type of sharp object to remove the o-rings.

**B. REMOVE AUGER**

1. Remove the front auger support and bushing.
2. Remove the auger assembly from the machine. Pull the auger out of the machine barrel slowly. As the auger is being pulled out, carefully remove each of the plastic flights with springs.
3. Keep the rear of the auger tipped up once it is clear of the freezing cylinder to prevent the rear seal assembly from dropping.
4. Wipe the spline lubricant off of the hex end of the auger with a paper towel. Remove the rear seal assembly (Fig. 3-5).
5. Unscrew the springs from the auger flights.

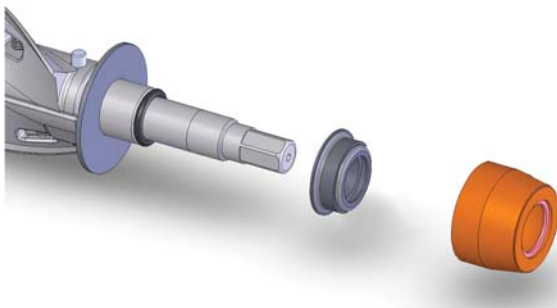

**Figure 3-5 Rear Seal Assembly**

**3.4 CLEANING DISASSEMBLED PARTS**

Disassembled parts require complete cleaning, sanitizing and air drying before assembling. Local and state health codes will dictate the procedure required. Some state health codes require a four sink process (pre-wash, wash, rinse, sanitize, air dry), while others require a three sink process (without the pre-wash step). The following procedures are a general guideline only. Consult your local and state health codes for the procedures required in your location.

- A. Disassemble all parts.
- B. Place all front door and auger parts in clean 90° to 110°F (32°C to 43°C) water and wash thoroughly (four sink procedure only).
- C. Place all parts in 90° to 110°F (32°C to 43°C) mild detergent water and wash thoroughly.
- D. Rinse all parts with clean 90° to 110°F (32°C to 43°C) water.
- E. Sanitize all machine parts following procedures outlined below.

**3.5 SANITIZING PARTS**

- A. Use a sanitizer, mixed according to manufacturer's instructions, to provide a 100 parts per million strength solution. Mix sanitizer in quantities of no less than 2 gallons of 90° to 110°F (32°C to 43°C) water. Any sanitizer must be used only in accordance with the manufacturer's instructions.
- B. Place all parts in the sanitizing solution for 5 minutes, then remove and let air dry completely before assembling in machine.

**3.6 CLEANING THE MACHINE**

The exterior should be kept clean at all times to preserve the luster of the stainless steel. A high grade of stainless steel has been used on the machine to ease cleanup. To remove spilled or dried mix, wash the exterior with 90° to 110°F (32°C to 43°C) soapy water and wipe dry.

Do not use highly abrasive materials, as they will mar the finish. A mild alkaline cleaner is recommended. Use a soft cloth or sponge to apply the cleaner. For best results, wipe with the grain of the steel.

- A. Clean the rear seal surfaces on the inside of the freezing cylinders.
- B. Using sanitizing solution and the large barrel brush provided, sanitize the freezing cylinders by dipping the brush in the sanitizing solution and brushing the inside of the freezing cylinders.
- C. Remove the drip trays from the front panel. Clean and replace the drip trays.

### 3.7 ASSEMBLING THE MACHINE

To assemble the machine parts, refer to the following steps:

#### NOTICE

*Petrol-Gel sanitary lubricant or equivalent must be used when lubrication of machine parts is specified.*

#### NOTICE

*The United States Department of Agriculture and the Food and Drug Administration require that lubricants used on food processing equipment be certified for this use. Use lubricants only in accordance with the manufacturer's instructions.*

- A. Assemble all o-rings onto parts dry, without lubrication. Then apply a thin film of sanitary lubricant to exposed surfaces of the o-rings.
- B. Install the rear seal o-ring. Lubricate the outside of the rear seal o-ring with sanitary lubricant.
- C. Install the stainless steel rear seal adapter into the rear seal dry (without lubricant). Lubricate the inside surface of the rear seal adapter and install it onto the auger shaft. DO NOT lubricate the outside of the rear auger seal (Fig. 3-6).

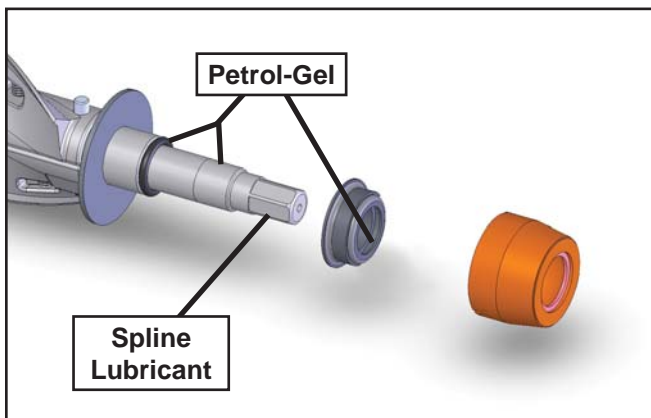

**Figure 3-6 Rear Seal Assembly**

- D. Lubricate the hex drive end of the auger with a small amount of spline lubricant. A small container of lubricant is shipped with the machine.
- E. Screw the springs onto the studs in the plastic flights. The springs must be screwed into the flights completely to provide proper compression.
- F. Install the two plastic flights onto the rear of the auger and insert it part way into the freezing cylinder.
- G. Install the remaining plastic flights, push the auger into the freezing cylinder and rotate slowly until the auger engages the drive shaft.

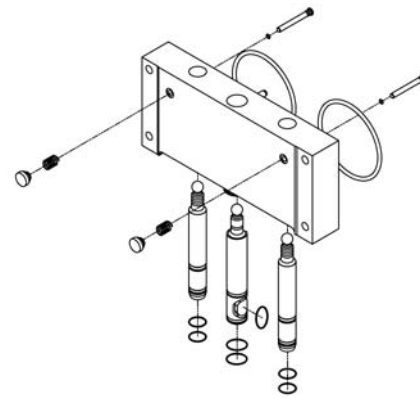

**Figure 3-7 Front Door**

- H. Apply a thin layer of sanitary lubricant to the inside and outside of the auger support bushing. Install the bushing onto the auger support and install the auger support into the front of the auger. Rotate the auger support so that one leg of the support points straight up.
- I. Assemble the air bleed valve o-ring onto the air bleed valve. Position the o-ring into the groove close to the wide part. Apply a thin film of sanitary lubricant to the o-ring.
- J. Insert the air bleed valve into the back of the front door. Install the compression spring onto the air bleed valve then screw the knob on finger tight.
- K. Apply a thin layer of sanitary lubricant to the o-rings on the spigot bodies and install the spigot bodies through the bottom of the front door.
- L. Fit the front door o-ring into the groove on the rear of the front door.
- M. Place the front door assembly on the mounting studs and the push front door against the machine carefully.
- N. Secure the front door to the machine by placing the knobs on the studs and tightening until finger tight. Do not overtighten. Proper o-ring seal can be observed through the transparent front door.

### 3.8 SANITIZING

Sanitizing must be done after the machine is clean and just before the machine is filled with mix. Sanitizing the night before is not effective. However, you should always clean the machine and parts after using it.

#### NOTE

*The United States Department of Agriculture and the Food and Drug Administration require that all cleaning and sanitizing solutions used with food processing equipment be certified for this use.*

When sanitizing the machine, refer to local sanitary regulations for applicable codes and recommended sanitizing products and procedures. The frequency of sanitizing must comply with local health regulations. Mix sanitizer according to manufacturer's instructions to provide a 100 parts per million strength solution. Mix sanitizer in quantities of no less than 2 gallons of 90°F to 110°F (32°C to 43°C) water. Allow sanitizer to contact the surfaces to be sanitized for 5 minutes. Any sanitizer must be used only in accordance with the manufacturer's instructions.

<b>CAUTION</b>
<b>Risk of Product Damage</b>
Avoid prolonged contact of sanitizer with machine parts. Sanitizer may cause corrosion of stainless steel parts if there is prolonged contact.

- A. Prepare 3 gallons of sanitizing solution following manufacturer's instructions, and pour it into the storage container.
- B. Make sure the display shows the freezing cylinder is off. If it is not, press the On/Off Left or On/Off Right button to turn it off.

**NOTE**

*If the freezing cylinder is not off, the control will not go into Clean mode. This is to protect from accidentally going into Clean mode.*

- C. Press the Pump button to turn the pump ON and open the air bleed valve on the front door by pushing the valve in and holding (see Figure 3-8).



**Figure 3-8 Air Bleed Valve**

- D. Let sanitizing solution fill the freezing cylinder to the air bleed valve, then close the valve by pulling it out to lock in place.

- E. Press the CLEAN button to start the auger rotating.
- F. Check for leaks when the freezing cylinder is first pressurized with sanitizing solution.
  1. Check for leaks at the front door seals.
  2. Check the drain tray located in the front panel for leaks coming from the rear of the rear auger seal.
  3. Check the inside of the cab unit for leaks at the hose connections.
- G. Use a sanitized soft bristle brush dipped in sanitizing solution to clean the mix container.
- H. After five minutes, open the spigot to drain the sanitizing solution.
- I. When the solution has drained, press the Pump and Clean buttons to stop the pump and auger. Allow the freezing cylinder to drain completely.

The machine is now sanitized and ready for adding mix.

**3.9 FREEZE DOWN AND OPERATION**

Refer to the following procedures to operate both freezing cylinders.

- A. Sanitize immediately before use.
- B. Make sure the display shows the freezing cylinder is off. If it is not, press the On/Off Left or On/Off Right button to turn it off.
- C. Fill the storage containers with at least 3 gallons of mix.
- D. Attach the mix inlet probe to the container and place the container in the refrigerated cab.
- E. Press the Pump button to turn the pump on.
- F. Place a container under the spigot and open the spigot to allow the mix to flush out about 8 ounces (0.23 liters) of sanitizing solution and liquid mix. Close the spigot.
- G. Open the air bleed valve on the front door by pressing and holding. Hold the valve open until the mix level in the freezing cylinder is 1/2" from the air bleed valve.
- H. Press the On/Off button for the cylinder.
- I. Press the PUSH TO FREEZE button.

- J. When the product is ready, the display will read “SERVE”. Open the spigot to dispense product.

**NOTE**

*If the product consistency needs to be adjusted, use the Technician passcode and go to the Basic Settings menu. Adjust the CutOut Consistency higher to increase the consistency or lower to decrease the consistency. Make adjustments in increments of 5 for best results.*

- K. The machine dispenses product at a reasonable draw rate. If the machine is overdrawn, the result is a soft product or a product that will not dispense at all. If this occurs, allow the machine to run for approximately 30 seconds before dispensing more product. A dispense rate adjustor is located under the header panel, to the immediate right of the spigot handle. Turning the knob counterclockwise will decrease the dispense rate.
- L. Do not operate the machine when the MIX LOW message is displayed. Refill the mix container immediately.

**NOTE**

*After a preset number of freezing cycles in Serve mode, the control will enter the sleep mode and remain there until someone draws product or presses the PUSH TO FREEZE button. In the sleep mode, the machine will keep the product below 41°F (5°C). Sleep mode does not take the place of cleaning and sanitizing. Federal, State, and local regulatory agencies determine frequency of cleaning and sanitizing.*

**3.10 MIX INFORMATION**

Mix can vary considerably from one manufacturer to another. Differences in the amount of butterfat content and quantity and quality of other ingredients have a direct bearing on the finished frozen product. A change in machine performance that cannot be explained by a technical problem may be related to the mix.

Proper product serving temperature varies from one manufacturer’s mix to another. Mixes should provide a satisfactory product in the 20°F to 24°F range. Diet and low-carb mixes typically freeze to proper consistency at higher temperatures.

When checking the temperature, stir the thermometer in the frozen product to get an accurate reading.

Old mix, or mix that has been stored at too high a temperature, can result in a finished product that is unsatisfactory. To retard bacteria growth in dairy based mixes, the best storage temperature range is between 33° to 38°F (0.5° to 3.3° C).

**3.11 OPERATION OF MIX PUMP**

The mix pumps are operated from the buttons on the IntelliTec2™ touchpad. When the pump button is pressed On, the mix pump motor will start pumping mix into the freezing cylinder. When the set pressure is reached, the mix pump will shut off automatically.

**NOTE**

*The mix pump motor is equipped with an internal overload that will “trip”, disabling the pump when the motor is overloaded. Consult the troubleshooting section for corrective information. The internal overload will automatically reset after cooling. If the condition continues, contact a qualified service person.*

- A. Mix Operation: The peristaltic mix pump contains one continuous mix pump hose. When looking at the face of the peristaltic mix pump, the left side of the hose is the mix intake or pickup. The right side of the hose is the mix discharge. Mix is drawn up the pickup side of the hose and transferred through the discharge side to the machine (Fig. 3-9).
- B. Air Operation: The air compressor operates whenever the peristaltic mix pump is running. Air enters through a check valve on the piston downstroke. The air is discharged through a second check valve, on the piston upstroke. The air and mix join at the tee and then travel to the machine.
- C. The overrun adjustment is preset at the factory. If an adjustment becomes necessary, refer to Section 4.

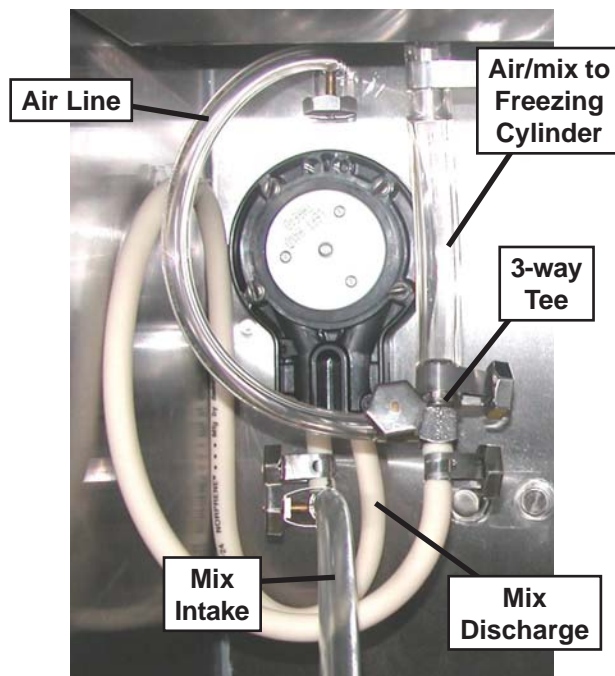

**Figure 3-9 Mix Pump Hose Routing**



### 3.12 MIX PUMP CLEANING

#### NOTICE

*Any cleaning procedure must always be followed by sanitizing before filling machine with mix.*

The mix pump is approved for CIP (clean in place). It is thoroughly cleaned when the cleaning solution is pumped through the machine. We recommend completely disassembling the pump and disconnecting tubing every 14 days for inspection of parts to confirm the CIP has been properly performed. If any residue is detected, clean or replace those parts as outlined below.

- A. With the machine filled with mix, press the Clean button. Allow the auger to agitate for 5 to 10 minutes.
- B. Remove the suction tube from the mix container. Open the spigot to remove the mix remaining in the freezing cylinder.
- C. Pump 2 gallons (7.5 liters) of potable water through machine until the water coming out of the spigot is clear.
- D. Pump 2 gallons (7.5 liters) of 90° to 110°F (32°C to 43°C) cleaning solution through the machine.
- E. Press the Pump button to turn the pump Off. Open the spigot to relieve the remaining pressure.
- F. Press the Clean button to stop the cleaning cycle and press the On/Off button for the cylinder to turn it Off.

### 3.13 DISASSEMBLY AND INSPECTION OF REMOVABLE PARTS

Inspection of removable parts should be made whenever maintenance is performed or when the pump requires disassembly.

#### NOTE

*If the mix line or air line is difficult to remove, soften the tubing with a rag soaked in hot water. Hose connections may be sprayed with Haynes Sanitary Lubricant for ease of removal.*

#### WARNING

##### Hazardous Moving Parts

Revolving pump head can grab, mangle, and cause serious crushing injury. Make sure the display shows the freezing cylinders and pump are off. If they are not, press the On/Off button and Pump button to turn them off.

#### CAUTION

##### System Under Pressure

Never disconnect hoses from the machine or the pump without first opening the spigot to relieve pressure.

- A. Loosen the clamp and remove the air hose from the pump compressor.
- B. Loosen the clamp and disconnect the mix pump hose. Remove the pickup hose, and the mix pickup assembly from the mix container.
- C. Completely disassemble the hose assembly and the check valve (Fig. 3-10). Place hoses, tee, check valve assembly, and pickup hose adapter in 90° to 110°F (32°C to 43°C) mild detergent water and wash thoroughly. Use soft bristle brushes to clean inside of fittings. Rinse all parts in clean 90° to 110°F (32°C to 43°C) water.
- D. Carefully inspect each part for wear or damage. Replace worn or damaged parts.
- E. Wash the mix tube and the air tube in the cabinet with 90° to 110°F detergent water and brushes provided. Rinse with clean, 90° to 110°F water.
- F. Prepare two gallons (7.5 liters) of sanitizing solution using a USDA certified grade sanitizing solution. Sanitize all removed parts. Allow them to air dry.
- G. Reassemble both hose assemblies per the diagram located on the inside of the cab door. Reconnect the assemblies to the pump hose and the discharge hose, using the clamps. (Refer to Section 2.5 Mix Pump).
- H. Sanitize assembled machine as per instructions outlined in Section 3.11.



Figure 3-10 Mix Pump Removable Parts



## SECTION 4 MAINTENANCE AND ADJUSTMENTS

This section is intended to provide maintenance personnel with a general understanding of the machine adjustments. It is recommended that any adjustments in this section be made by a qualified person.

### 4.1 OVERRUN ADJUSTMENT

The product, when served, is a combination of air and mix. Overrun is a measure of the amount of air blended into the mix.

Overrun can be expressed in terms of the amount of weight loss for a given volume. For example, if a pint of liquid mix weighs 18 ounces and a pint of frozen product with air added weighs 12 ounces, the overrun is said to be 50 percent:  $18 \text{ oz.} - 12 \text{ oz.} = 6 \text{ oz.}$ ,  $(6/12) \times 100 = 50\%$

The overrun can be checked by placing a one pint container on an ice cream scale and zeroing out the scale. Then fill a one pint container with frozen product. The container should be filled over the top and leveled with a straightedge. The product should not contain any air pockets. When weighed on an ice cream scale, one pint of product should weigh 12 to 13 ounces.

The mix pump has been preset at the factory to produce a product with approximately 40% overrun. Because of differences in mix formulation, temperatures and barometric pressure, this figure may vary. It will be necessary for approximately 2 gallons of mix to be pumped through the machine before overrun changes in the product are noticeable.

Overrun is controlled by the length of the air compressor piston stroke within the piston cylinder. Lengthening the stroke within the cylinder will increase overrun. Conversely, shortening the stroke will decrease overrun. To perform an overrun adjustment, refer to the following procedure:



**Figure 4-1 Overrun Adjustment**

- A. Press the Pump button to turn the pump power Off. Disconnect power sources/circuit breakers.
- B. Remove the back panel from the machine.

- C. On the air compressor side of the pump, locate the long/slender piston rocking arm. The rocking arm downward travel is limited by a stationary cam. On the face of the cam there is an overrun setting indicator plate numbered 3 through 8 and an adjustment knob (Fig. 4-1).
- D. The overrun setting is indicated by a pin.
- E. To adjust overrun, loosen the allen-head screw (located within the center of the adjustment knob) with the 5/32" allen wrench provided. Rotate the adjustment knob counterclockwise to a higher number for higher overrun, or clockwise to a lower number for lower overrun. Each number multiplied by 10 approximately represents the overrun percentage (i.e. setting 4 = 40% overrun).
- F. Tighten the allen screw, then place the wrench back in its clip. Replace the lower back panel and secure with the four screws. Press the Pump button to turn the pump power On.

### 4.2 MIX PUMP HOSE REPOSITION

Mix pump hose must be repositioned every 800 gallons of mix pumped or every 2 weeks. Failure to reposition the hose will result in reduced mix pump liquid capacity, dispense stoppage, popping, and possible mix pump hose leakage. Follow the steps below to reposition the hose:

- A. Run cleaning solution through pump.
- B. Turn the pump off and relieve any pressure by opening the spigot.
- C. Grasp the pickup hose end of the mix pump hose with one hand and turn the pump on. Pull down on the pickup hose end until 12 to 14 inches of tubing has fed through the pump then turn the pump off (Fig. 4-2).
- D. Loosen the small clamp at the pick-up hose adapter and disconnect the mix pump hose.
- E. Cut 7-1/2 inches off the end of the mix pump hose.
- F. Reconnect the mix pump hose to the adapter.
- G. Continue normal operation. Mix hose will automatically reposition itself with the adapter near the black cover.

#### NOTE

*Each hose is long enough for 3 repositions before replacement is required.*

#### NOTE

*The hose timer must be reset each time the hose is repositioned or replaced to keep an accurate record of the hose service time.*

- H. From the Current Status screen on the control press the left arrow button.
- I. Press the right arrow, SET, then select button to get technician access to the control
- J. From the Main Menu scroll down and select the Errors and Statistics option.
- K. Select the Machine Statistics option.
- L. Press the right arrow button to get to the Machine Statistics (9 of 10)
- M. Move the cursor to the "Reset Hose Service Time" and press the select button.
- N. Press the left arrow button until the Current Status screen is displayed.

**NOTE**

*The hose timer must be reset each time the hose is repositioned or replaced to keep an accurate record of the hose service time.*

**4.3 MIX PUMP HOSE REPLACEMENT**

Mix pump hose must be replaced when tubing cannot be further repositioned (every four to eight weeks). Failure to comply will result in hose failure and possible pump damage. Follow the steps below to replace the hose:

- A. Run cleaning solution through pump.
- B. Turn the pump off and relieve any pressure by opening the spigot.
- C. Disconnect the mix pump hose at each end.
- D. Grasp the discharge hose end with one hand and turn the pump on. Pull down on the hose until all of the remaining hose is removed from the pump. Turn pump off.
- E. Rotate pump roller assembly so one roller is at the 6:00 position.

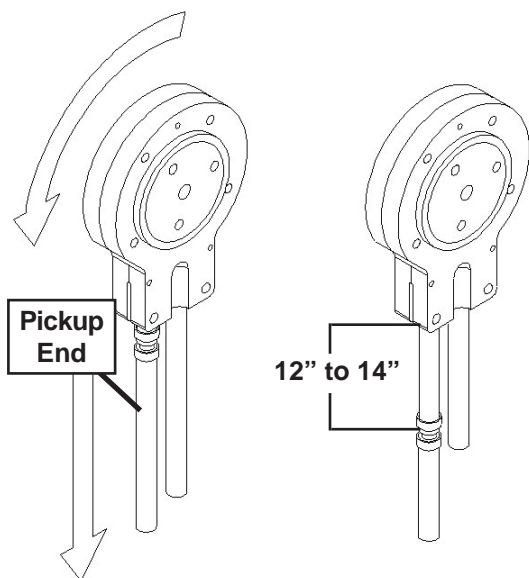

**Figure 4-2 Pump Hose Reposition**

- F. Use a brush that fits in the opening and clean the pump roller assembly, first with detergent water and then clear water.
- G. Connect the new mix pump hose to the pickup hose adapter using the small clamp.
- H. Feed one end of the mix pump hose into the pickup hose side (left) of the black cover.

**NOTE**

*Feed the tube into the clamp so the natural curve of the tube is towards the outside of the black cover. This prevents the hose from looping around the black cover twice.*

- I. Gently push the hose into the black cover until it begins to feed.
- J. Allow the hose to feed itself through the pump until about 6" (15cm) remains on the entering side and turn the pump off.
- L. Connect the mix pump hose to the elbow fitting (located on the left side of the mix line manifold) using a small hose clamp. Be careful not to twist the mix hose.
- M. Turn the pump on.
- N. Allow the remaining 6" (15cm) of tubing to feed through the pump until the hose adapter prevents further feeding and turn the pump off.

**CAUTION**

**Risk of Product Damage**

Air/Mix Tee must remain below the black cover clamp. If the Tee is above the pump, the mix may drain into the air compressor, resulting in pump damage.

- P. Connect the free end of the mix pump hose to the 3-way Tee. When all connections are complete, the 3-way Tee must be lower than the black pump housing.
- Q. The pump is now ready to sanitize.

**NOTE**

*The hose timer must be reset each time the hose is repositioned or replaced to keep an accurate record of the hose service time. Refer to Section 4.2 H-N for instructions on resetting the timer.*



#### 4.4 FINE CONSISTENCY ADJUSTMENT

Product consistency can be adjusted on the Fine Consistency Adjustment screen. To get to the Fine Consistency Adjustment Screen, press the right arrow then the SEL button from the Current Status screen. Then move the cursor to the Fine Consistency Adjustment option and press the SEL button.

Fine Consistency Adjustment	
Cylinder	Right
Changing the fine consistency change the firmness of the product.	
Consistency CutIn Limit	00
Consistency CutOut Limit	00
_ Fine Consistency	000

**Figure 4-2 Fine Consistency Adjustment**

Increasing the Fine Consistency number increases the product consistency (firmer product). The Consistency Limits show the Fine Consistency adjustment added to the Consistency number.

#### 4.5 DRIVE BELT TENSION ADJUSTMENT

To check belt tension, follow the steps below:

- A. Remove a side panel and the back panel.
- B. Use a Burroughs Belt Tension Gauge to set the tension for the drive belt. Set the belt tension to 55-60 lbs.
- C. If an adjustment is necessary, loosen the four motor plate retaining nuts, adjust belt tension then retighten the four nuts.
- D. Using a straightedge, check that the drive motor pulley is aligned with the speed reducer pulley. Align the pulley if necessary.

#### NOTE

*Belt life will be increased if new drive belts are tightened after two or three weeks of operation.*

#### 4.6 CONDENSER CLEANING (AIR-COOLED MACHINES)

The condenser requires periodic cleaning. To clean the condenser, refer to the following steps:

- A. Remove the side panel and take out the condenser filter. Visually inspect the condenser filter for dirt.
- B. If the condenser filter is dirty, vacuum or brush it clean. Rinse it with clean water and allow it to dry before replacing it on the machine.
- C. Visually inspect the condenser for dirt by shining a light through the coil of the condenser.
- D. If the condenser is dirty, place a wet towel over the condenser.
- E. Using compressed air or a CO<sub>2</sub> tank, blow out the dirt from the inside of the condenser. Most of the dirt will cling to the wet towel.

#### NOTE

*If the condenser is not kept clean, refrigeration efficiency will be lost.*

#### 4.7 PREVENTATIVE MAINTENANCE

It is recommended that a preventative maintenance schedule be followed to keep the machine clean and operating properly. The following steps are suggested as a preventative maintenance guide.

The United States Department of Agriculture and the Food and Drug Administration require that lubricants used in food zones be certified for this use. Use lubricants only in accordance with the manufacturer's instructions.

- A. Daily checks  
Check for any unusual noise or condition and repair immediately.
- B. Monthly checks
  1. Check drive belts for wear and tighten belts if necessary. (Refer to section 4.12)
  2. Check the condenser filter for dirt. (Refer to section 4.13).

#### 4.8 EXTENDED STORAGE

Refer to the following steps for winterizing the machine or for storing the machine over any long period.

- A. Clean all of the parts that come in contact with mix thoroughly with warm detergent . Rinse in clear water and dry all parts. Do not sanitize.

#### NOTE

*Do not let cleaning solution stand in machine barrel or mix pump during the shutdown period.*

- B. Remove, disassemble, and clean the front door, auger shaft, and mix pump. Leave disassembled during the shutdown period.

- C. Place the plastic auger flights in a plastic bag with a moist paper towel. This will prevent the flights from becoming brittle if exposed to dry air over an extended period (over 30 days).
- D. For water-cooled machines that are left in unheated buildings, or buildings subject to freezing, the water must be shut off and disconnected. Disconnect the water inlet fitting. The fitting is located at the rear of the machine. Run the compressor for 2 - 3 minutes to open the water valve (the front door must be attached for the compressor to run). Blow out all the water through the water inlet. Drain the water supply line coming to the machine. Disconnect the water outlet fitting.
- E. Disconnect the machine from the source of the electrical supply in the building.

## SECTION 5 TROUBLESHOOTING

### 5.1 ERROR CODES

When the machine experiences a problem, one of the following error codes will be displayed on the control panel. Each error code directs you to the system location of the malfunction.

#### ERROR CODE MALFUNCTION

2	High Torque
3	Run Time
4	Clean
5	Freezing Cylinder Sensor
6	Hopper Sensor (single hopper machines)
7	Drive Motor
8	Cab Sensor
9	High Pressure Cutout
10	Auxiliary Sensor
11	Prime (cab units only)
12	Left Hopper Sensor
13	Right Hopper Sensor
21	Spigot Open Time

To return the machine to normal operation, any error causing condition must be corrected and the power to the affected freezing cylinder must be cycled. Turn the power to the freezing cylinder off then back on using the On/Off button of the affected freezing cylinder.

### 5.2 TROUBLESHOOTING

#### Error Code 2 - High Torque

If the control panel displays a High Torque Error (E2), the controller has sensed that the drive motor is running at a high load for 10 or more seconds. This may be due to the product consistency adjustment being set too high. Press the On/Off button for the cylinder to turn it off, wait until the product in the freezing cylinder thaws and then turn the cylinder back on. Follow the instructions in Section 3 to reduce the product consistency by a few levels. If the error persists, contact your Authorized Stoelting Distributor for further assistance.

#### Error Code 3 - Run Time

The Run Time Error (E3) occurs when the compressor runs continuously for an extended period. This error is generally caused by very low mix levels in the mix container or from product breakdown. Another common cause results from a restriction preventing mix from entering the freezing cylinder. Check the mix in the mix container. If the level mix is low, add mix. If there is a possibility that the mix has broken down, clean and sanitize the machine and replace the mix with fresh product.

Ice crystals in the mix container can clog the mix inlet system and prevent mix from entering the freezing cylinder. Thoroughly thaw mix per manufacturer's recommendations. To check for ice crystals, pour a small amount of product from the mix container through a clean and sanitized sieve or strainer.

In air cooled machines, the Run Time Error may indicate that airflow within the machine has reduced or stopped. Check the sides and top of the machine for anything that would restrict airflow.

If the error persists after attempting to clear it, contact your Authorized Stoelting Distributor for further assistance.

#### Error Code 4 - Clean

If the machine is left in the Clean Mode for more than 20 minutes, the control panel will display a Clean Error (E4). This condition does not reflect a problem with the machine itself. The Clean Error has been programmed into the controller as a safeguard to protect the machine from potential damage caused by the machine being accidentally left in "Clean Mode". To clear the Clean Error, press the On/Off button for the cylinder to turn it off then back on.

### **Error Code 5 - Freezing Cylinder Sensor**

The Freezing Cylinder Sensor Error (E5) indicates a failure of the barrel sensor or if the sensor is out of range. If the control panel displays an E5, press the On/Off button for the cylinder to turn it off then back on. If the error persists, contact your Authorized Stoelting Distributor for further assistance.

#### **NOTE**

*When the machine encounters a Freezing Cylinder Sensor Error, the machine will continue to run using preset timers. This mode will allow the operator to continue serving product until the machine can be serviced.*

### **Error Code 6 - Hopper Sensor (single hopper machines)**

The Hopper Sensor Error (E6) will not occur on the machine.

### **Error Code 7 - Drive Motor**

If the control panel displays a Drive Motor Error (E7), the control does not sense current coming from the drive motor. Press the On/Off button for the cylinder to turn it off then back on. If the error persists, contact your Authorized Stoelting Distributor for further assistance.

### **Error Code 8 - Cab Sensor**

A Cab Sensor Error (E8) indicates a failure of the cabinet sensor or if the sensor is out of range. If the control panel displays an E8, press the On/Off button for the cylinder to turn it off then back on. If the error persists, contact your Authorized Stoelting Distributor for further assistance.

### **Error Code 9 - High Pressure Cutout**

High Pressure Cutout Errors (E9) are usually caused by a dirty or inefficient condenser. If the control panel displays an E9 on an air cooled machine, check for proper air clearance around the machine. If there is an E9 on a water cooled machine check for proper flow from the water supply or kinks in the hoses.

If the error persists, contact your Authorized Stoelting Distributor for further assistance.

### **Error Code 10 - Auxiliary Sensor**

An Auxiliary Temperature Sensor Error (E10) occurs if the temperature sensor on the control board fails. Press the On/Off button for the cylinder to turn it off then back on. If the error persists, contact your Authorized Stoelting Distributor for further assistance.

### **Error Code 11 - Prime Error**

The Prime Error (E11) occurs when the pump runs for an extended period. This usually occurs if there is a leak in the hose or if there is a low mix condition. If the error persists, contact your Authorized Stoelting Distributor for further assistance.

### **Error Code 12 - Left Hopper Sensor**

The Left Hopper Sensor Error (E12) will not occur on the machine.

### **Error Code 13 - Right Hopper Sensor**

The Right Hopper Sensor Error (E13) will not occur on the machine.

### **Error Code 21 - Spigot Open Time**

The Spigot Open Time Error (E21) indicates a failure of the spigot switch. If the control senses the spigot is open continuously for 10 minutes, the machine will go into Sleep 3 mode. If the control panel displays an E21, press the On/Off button for the cylinder to turn it off then back on. If the error persists, contact your Authorized Stoelting Distributor for further assistance.

### 5.3 TROUBLESHOOTING - MACHINE

PROBLEM	POSSIBLE CAUSE	REMEDY
<b>Machine does not run.</b>	<ol style="list-style-type: none"> <li>1 Power to machine is off.</li> <li>2 Freeze-up (auger will not turn).</li> <li>3 Front door not in place.</li> </ol>	<ol style="list-style-type: none"> <li>1 Supply power to machine.</li> <li>2 Turn off cylinder, wait for 15 minutes, then restart.</li> <li>3 Assemble front door in place.</li> </ol>
<b>Machine will not shut off.</b>	<ol style="list-style-type: none"> <li>1 No mix in the mix container.</li> <li>2 Spigot stuck open.</li> <li>3 Refrigeration problem.</li> </ol>	<ol style="list-style-type: none"> <li>1 Add mix to the mix container.</li> <li>2 Make sure spigot is fully closed.</li> <li>3 Check system. (Call distributor for service)</li> </ol>
<b>Product is too firm.</b>	<ol style="list-style-type: none"> <li>1 CutOut Consistency setting too high</li> </ol>	<ol style="list-style-type: none"> <li>1 Adjust the CutOut Consistency (See Section 4)</li> </ol>
<b>Product is too soft.</b>	<ol style="list-style-type: none"> <li>1 No vent space for free flow of cooling air.</li> <li>2 Condenser is dirty.</li> <li>3 CutOut Consistency setting too low</li> <li>4 Auger is assembled incorrectly.</li> <li>5 Refrigeration problem.</li> </ol>	<ol style="list-style-type: none"> <li>1 A minimum of 3" of air space at the back. (See Section 2)</li> <li>2 Clean the condenser. (See Section 4)</li> <li>3 Adjust the CutOut Consistency (See Section 4)</li> <li>4 Remove mix, clean, reassemble, sanitize and freeze down.</li> <li>5 Check system. (Call distributor for service)</li> </ol>
<b>Product does not dispense.</b>	<ol style="list-style-type: none"> <li>1 No mix in the mix container.</li> <li>2 Drive motor overload tripped.</li> <li>3 Drive belt failure.</li> <li>4 Freeze-up (Auger will not turn).</li> <li>5 Auger turning counter-clockwise.</li> </ol>	<ol style="list-style-type: none"> <li>1 Add mix to the mix container.</li> <li>2 Wait for automatic reset. (If condition continues, call distributor for service.)</li> <li>3 Replace drive belt.</li> <li>4 Turn off cylinder, wait for 15 minutes, then restart.</li> <li>5 Change rotation to clockwise.</li> </ol>
<b>Drive belt slipping or squealing.</b>	<ol style="list-style-type: none"> <li>1 Worn drive belt.</li> <li>2 Freeze-up (Auger will not turn).</li> <li>3 Not tensioned properly.</li> </ol>	<ol style="list-style-type: none"> <li>1 Replace drive belt.</li> <li>2 Turn off cylinder, wait for 15 minutes, then restart.</li> <li>3 Adjust belt tension</li> </ol>
<b>Rear auger seal leaks.</b>	<ol style="list-style-type: none"> <li>1 Outside surface of rear auger seal is lubricated.</li> <li>2 Rear seal missing or damaged.</li> <li>3 Seal o-ring missing, damaged or installed incorrectly.</li> <li>4 Worn or scratched auger shaft.</li> </ol>	<ol style="list-style-type: none"> <li>1 Clean lubricant from outside of rear seal, lubricate inside of seal and reinstall.</li> <li>2 Check or replace.</li> <li>3 Check or replace.</li> <li>4 Replace auger shaft.</li> </ol>
<b>Front door leaks.</b>	<ol style="list-style-type: none"> <li>1 Front door knobs are loose.</li> <li>2 Spigot parts are not lubricated.</li> <li>3 Chipped or worn spigot o-rings.</li> <li>4 O-rings or spigot installed wrong.</li> <li>5 Inner spigot hole in front door nicked or scratched.</li> </ol>	<ol style="list-style-type: none"> <li>1 Tighten knobs.</li> <li>2 See Section 3.</li> <li>3 Replace o-rings.</li> <li>4 Remove spigot and check o-ring.</li> <li>5 Replace front door.</li> </ol>

## 5.4 TROUBLESHOOTING - MIX PUMP

PROBLEM	POSSIBLE CAUSE	REMEDY
<b>Pump motor does not run.</b>	<ol style="list-style-type: none"> <li>1 Power to pump is off.</li> <li>2 Low voltage.</li> <li>3 Mix pump hose jammed inside black cover/clamp.</li> <li>4 Pump motor overloaded.</li> <li>5 Pressure switch on pump is defective.</li> <li>6 Defective motor/capacitor.</li> </ol>	<ol style="list-style-type: none"> <li>1 Supply power to pump.</li> <li>2 Check for low voltage.</li> <li>3 Disconnect pump from power source. Remove four cover/clamp thumb screws. Separate cover/clamp halves and remove outer half. Remove jammed hose. Clean and re-install cover/clamp and tighten four thumb screws securely. Allow motor thermal overload to reset.</li> <li>4 Allow internal thermal overload to reset; determine overload cause and repair.</li> <li>5 Check mechanical operation and continuity of pressure switch.</li> <li>6 Check motor amperage draw and/or capacitor. Replace motor or capacitor.</li> </ol>
<b>Pump operates but cylinder will not fill.</b>	<p>Note 1: A properly working pump will fill an 8 oz. cup with mix in about 9 seconds.</p> <p>Note 2: Immediately after a bag change the pump may be unable to reestablish it's prime with the system at operating pressure. In this case, turn the pump off. Draw 2-3 pints to reduce system pressure to zero. Turn pump on. Purge remaining air in mix bag and pick-up hose.</p> <p><b>Important: before connecting the pick-up hose to the mix bag, remove as much air from the mix bag as possible.</b></p> <ol style="list-style-type: none"> <li>1 Out of Mix.</li> <li>2 Mix pump hose kinked inside black cover/clamp.</li> <li>3 Hoses assembled incorrectly.</li> <li>4 Mix pump hose service life is exceeded.</li> <li>5 Mix pump hose not connected to machine.</li> <li>6 Ice crystals in mix.</li> <li>7 Mix bag drawn against adapter.</li> <li>8 Foreign objects in mix.</li> <li>9 Check valve is backwards.</li> </ol>	<ol style="list-style-type: none"> <li>1 Replenish mix supply.</li> <li>2 Disconnect pump from power source. Remove four cover/clamp thumb screws. Separate cover/clamp halves and remove outer half. Remove jammed hose. Clean and re-install cover/clamp and tighten four thumb screws securely. Allow motor thermal overload to reset.</li> <li>3 Refer to diagram for correct hose connections.</li> <li>4 Reposition/replace mix pump hose. See Section 4</li> <li>5 Connect mix pump hose to machine.</li> <li>6 Completely thaw mix prior to use.</li> <li>7 Ensure bag is clear of pick-up tube.</li> <li>8 Clear blockage. Use fresh mix.</li> <li>9 Observe flow arrow for proper orientation.</li> </ol>
<b>Overrun too low or no overrun.</b>	<ol style="list-style-type: none"> <li>1 Overrun setting too low.</li> <li>2 Air leak.</li> <li>3 Air compressor not pumping air.</li> <li>4 Air check valve in backwards.</li> </ol>	<ol style="list-style-type: none"> <li>1 Increase overrun setting.</li> <li>2 Tighten all hose clamps.</li> <li>3 Contact local Stoelting Distributor.</li> <li>4 Check arrow for direction of flow.</li> </ol>

PROBLEM	POSSIBLE CAUSE	REMEDY
<b>Overrun too high.</b>	<ol style="list-style-type: none"> <li>Mix pump hose service life is exceeded.</li> <li>Out of mix.</li> <li>Overrun setting too high.</li> <li>Pick-up leg of mix pump hose is collapsing.</li> </ol>	<ol style="list-style-type: none"> <li>Reposition/replace mix pump hose.</li> <li>Replenish mix supply.</li> <li>Decrease overrun setting.</li> <li>Reposition hose.</li> </ol>
<b>Replacement mix pump hose won't feed through pump.</b>	<ol style="list-style-type: none"> <li>Feeding hose into discharge hole of mix pump cover.</li> <li>Hose ends not cut squarely.</li> <li>Force feeding too quickly.</li> <li>Pump motor not running.</li> </ol>	<ol style="list-style-type: none"> <li>Feed hose into suction side of cover.</li> <li>Carefully cut hose end off squarely (no tails).</li> <li>Gently and slowly assist feeding of hose up into pick-up hose side of cover.</li> <li>Press the Pump button to turn the pump On.</li> </ol>
<b>Air exiting mix pick-up hose.</b>	<ol style="list-style-type: none"> <li>Pickup tube check valve missing.</li> </ol>	<ol style="list-style-type: none"> <li>Contact local Stoelting Distributor.</li> </ol>
<b>Dispensed product air "pops"</b>	<ol style="list-style-type: none"> <li>Overrun setting too high.</li> <li>Mix pump hose service life is exceeded.</li> <li>Overdrawing the machine's capacity.</li> <li>Recent low mix condition.</li> </ol>	<ol style="list-style-type: none"> <li>Decrease overrun setting.</li> <li>Reposition/replace mix pump hose.</li> <li>Reduce dispense rate.</li> <li>Open spigot fully and allow excess air to escape.</li> </ol>
<b>Mix leakage from pump.</b>	<b>CAUTION: To prevent mix pump damage from dried mix deposits, immediately disassemble and clean pump.</b>	
	<ol style="list-style-type: none"> <li>Mix pump hose service life is exceeded.</li> </ol>	<ol style="list-style-type: none"> <li>Remove mix pump hose. Disconnect pump from power source. Remove mix pump cover/clamp. Clean the rollers a small amount of soapy water. Clean mix from pump. See Section 4.2 for hose replacement.</li> </ol>
<b>Pump is noisy/squeaking.</b>	<p>Note: The action of the air compressor rocking arm creates a repetitive clicking sound during operation. This is normal.</p> <p>Note: The peristaltic mix pump has three squeeze rollers that use self lubricating bearings. If squeaking exists with the mix pump hose in place and stops with the hose removed, the squeeze roller bearings can be lubricated using a silicone based spray. Remove the mix pump hose. Disconnect pump from electrical power. Remove four cover/clamp thumbscrews. Remove entire cover/clamp as one unit. Spray silicone based lubricant on each end of each squeeze roller. Spin rollers to work lubricant into bearings. Repeat as needed.</p> <p><b>Caution: Do not use cleaning/dissolving type lubricants like wd-40. These lubricants are not bearing friendly and will accelerate bearing wear.</b></p>	
<b>Mix in air hoses.</b>	<ol style="list-style-type: none"> <li>Air/mix tee above black cover/clamp.</li> <li>Air leak.</li> <li>Mix hose on wrong air/mix tee fitting.</li> </ol>	<ol style="list-style-type: none"> <li>Air/mix tee must be below black cover/clamp.</li> <li>Check stainless steel tube connection. Tighten all hose clamps.</li> <li>Refer to diagram for correct hose connections.</li> </ol>





## SECTION 6 REPLACEMENT PARTS

### 6.1 BRUSHES, DECALS AND LUBRICATION

Part Number	Description	Quantity
208135	Brush - 4" X 8" X 16" (Barrel)	1
208380	Brush - 1/4" X 3" X 14"	1
208465	Brush - 1" X 3-1/2" X 18"	1
208467	Brush - 3/8" X 1" X 5"	1
324103	Decal - Caution Rotating Shaft	1
324105	Decal - Caution Electrical Shock	1
324106	Decal - Caution Electrical Wiring Materials	1
324107	Decal - Caution Hazardous Moving Parts	1
324125	Decal - Danger Electric Shock Hazard	1
324141	Decal - Caution Rotating Blades	1
324208	Decal - Attention Refrigerant Leak Check	1
324346	Decal - Caution Hazardous Moving Parts	1
324509	Decal - Cleaning Instructions	1
324548	Decal - Adequate Ventilation 6"	1
324566	Decal - Wired According To	1
324594	Decal - Attention Heat Sensitive	1
324686	Decal - Danger Automatic Start	2
324728	Decal - Contactor Identification	1
324803	Decal - Domed Stoelting Logo (Large) (Header Panel)	1
324804	Decal - Domed Stoelting Swirl (Header Panel)	1
324887	Decal - Boost Transformer	1
508048	Lubricant - Spline (2 oz Squeeze Tube)	1
508135	Petrol Gel - 4 oz Tube	1
513640	Manual - Service	1

### 6.2 TRAYS

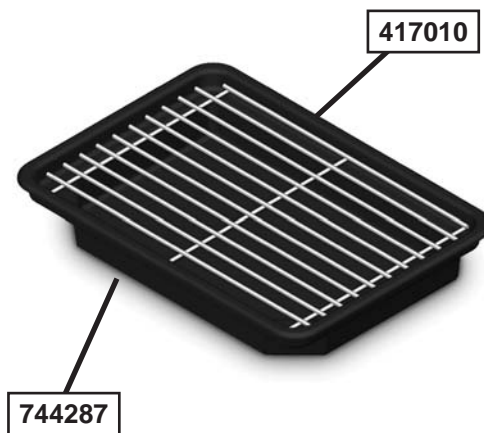

Part Number	Description	Quantity
417010	Grid - Drip Tray (Metal)	1
744252	Tray - Drain	1
744272	Tray - Drain (Cabinet)	1
744273	Tray - Drain	1

### 6.3 AUGER SHAFT AND FRONT DOOR PARTS

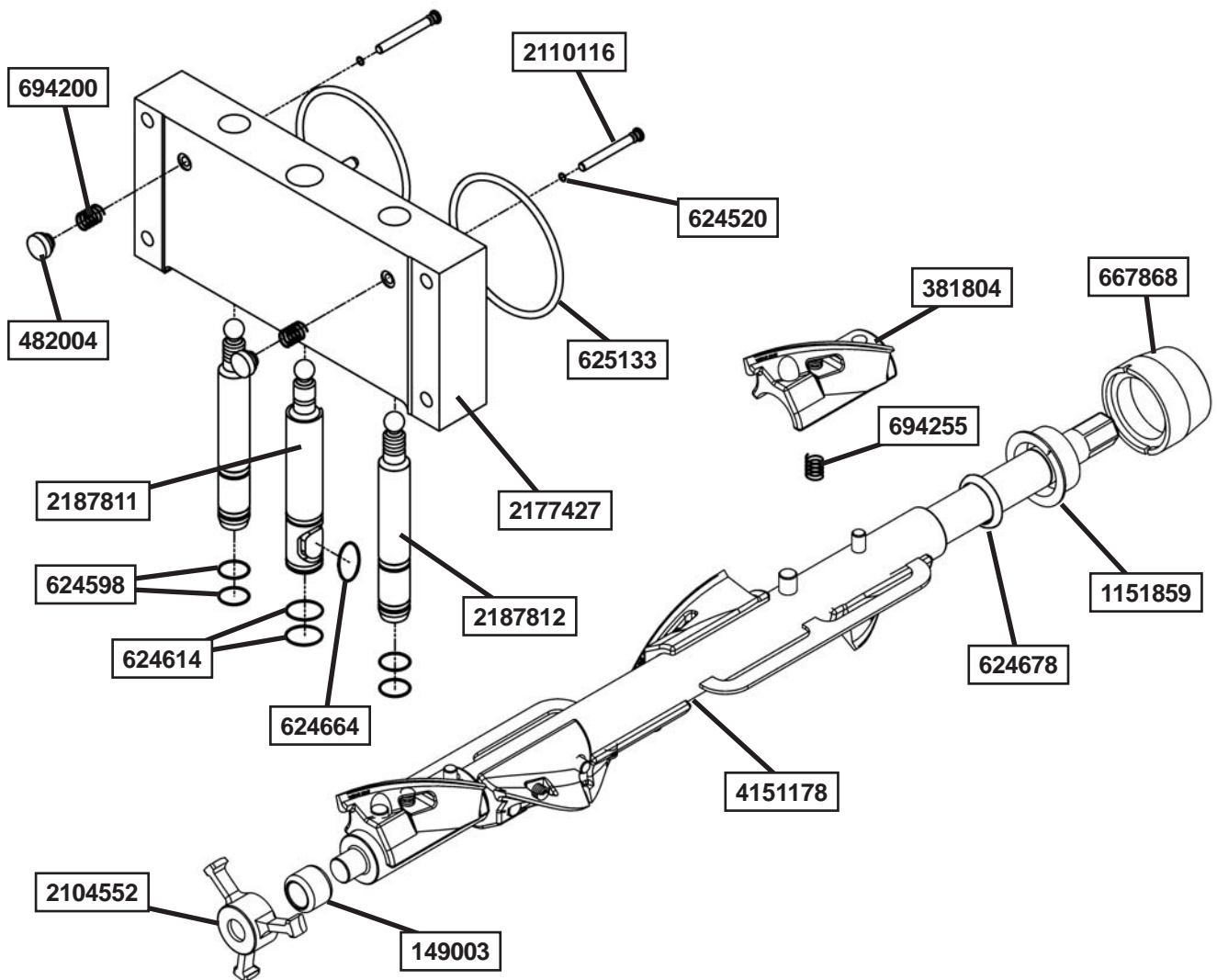

Part Number	Description	Quantity
149003	Bushing - Front Auger Support	2
381804	Auger Flight	12
482004	Knob (Air Bleed Valve)	2
482019	Knob - Front Door (Black)	4
624520	O-Ring - Air Bleed Valve - Black	2
624598	O-Ring - Outside Spigot - Black	4
624614	O-Ring - Top & Bottom Center Spigot - Black	2
624664	O-Ring - Middle Center Spigot - Black	1
624678	O-Ring - Rear Seal - Black	2
625133	O-Ring - Front Door - Black	2
667868	Seal - Rear Auger (Orange)	2
694200	Spring - Air Bleed Valve	2
694255	Spring - Auger Flight	12
1151859	Adapter - Rear Seal (Code 1) (Ser. #3899812HB Plus)	2
2104552	Support - Front Auger	2
2110116	Valve - Air Bleed	2
2177427	Front Door	1
2187880	Adapter - Rear Seal (Code 1)(Requires #624678)(Ser. #0 - #3899712HB)	2
2202179	Auger Shaft Auger Shaft (Ser. #0 - #3899712HB)	2
2187811	Spigot Body - Center	1
2187812	Spigot Body - Outer	2
4151178	Auger Shaft Auger Shaft (Ser. #3899812HB Plus)	2

## 6.4 CAB TUBING

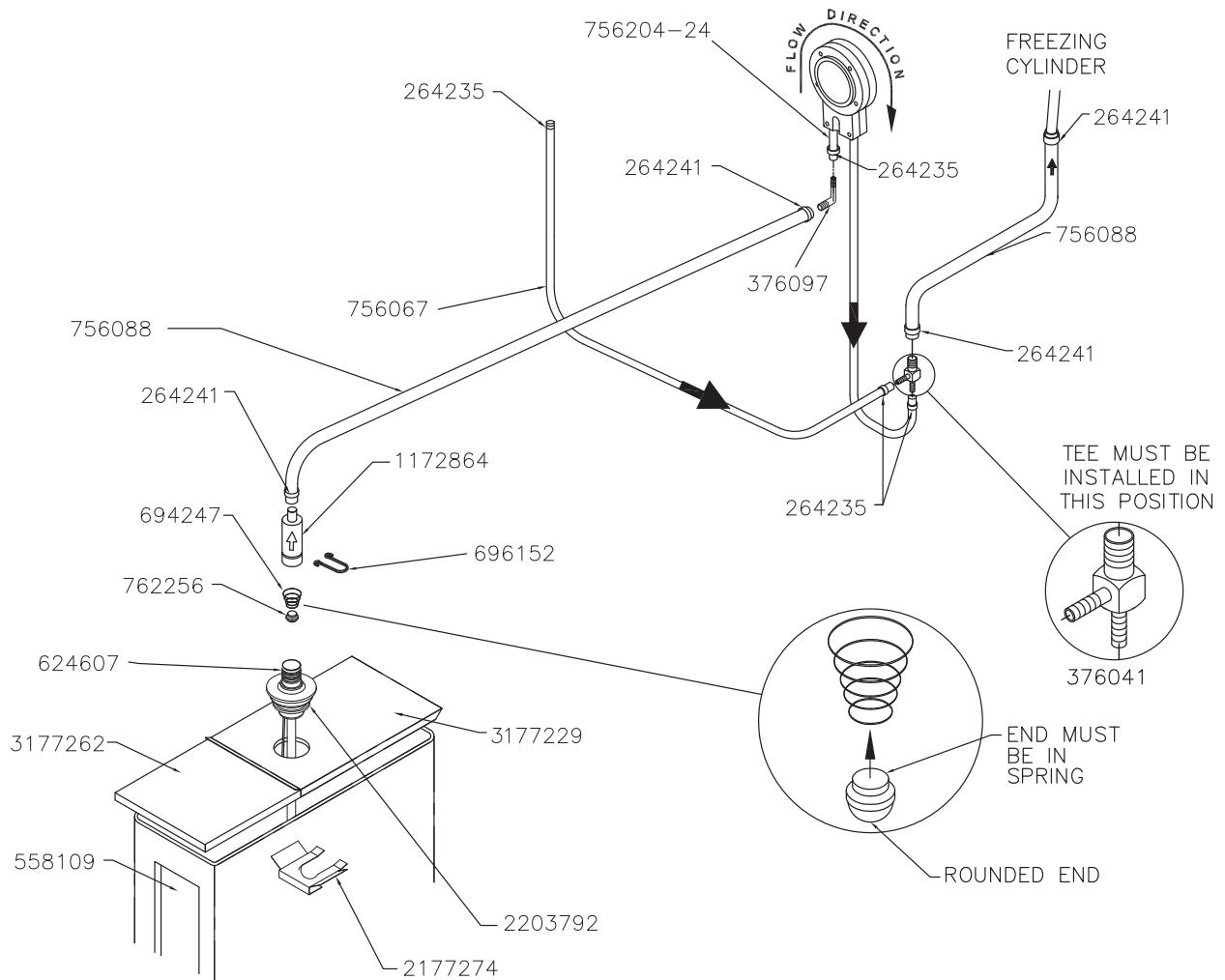

Part Number	Description	Quantity
264235	Clamp - Metal (1/4" ID Tubing)	8
264241	Clamp - Metal (1/2" ID Tubing)	8
376041	Tee Connector - 3-Way (Stainless)	2
376097	Elbow - Barbed (1/2"- 1/4")	2
558109	Mix Container Only	2
624607-5	O-Ring - Check Valve Body - Black (5 Pack)	4
694247	Spring - Check Valve	2
696152	Clip - Lock (Check Valve)	2
756067	Tubing - 1/4" ID - Clear - Air Line (25' Increments) (Per Inch)	13"(2)
756088	Tubing - 1/2" ID - Clear - Mix Line (25' Increments) (Per Inch)	21"(2) and 6"(2)
756204	Tubing - 1/4" ID - Pump (50' Box Only) (Per Inch)	-
756204-40	Tubing - 1/4" ID - Pump (Pre-Cut 40" Piece)	4
762256	Check Valve - Mix Outlet	2
1172864	Check Valve - Mix In Line (Outer)	2
2177274	Clip - Retaining (Mix Probe To Cover)	2
2203792	Pick-Up Tube - Mix	2
3177229	Cover - Rear (Mix Container)	2
3177262	Cover - Front (Mix Container)	2





**DOMESTIC WARRANTY  
(Including Mexico)  
SOFT SERVE / SHAKE EQUIPMENT**

1. **Scope:**  
PW Stoelting, L.L.C. (“Stoelting”) warrants to the first user (the “Buyer”) that the freezing cylinders, hoppers, compressors, drive motors, speed reducers, and augers of Stoelting soft serve / shake equipment will be free from defects in materials and workmanship under normal use and proper maintenance appearing within five (5) years, and that all other components of such equipment manufactured by Stoelting will be free from defects in material and workmanship under normal use and proper maintenance appearing within twelve (12) months after the date that such equipment is originally installed.
  
2. **Disclaimer of Other Warranties:**  

**THIS WARRANTY IS EXCLUSIVE; AND STOELTING HEREBY DISCLAIMS ANY IMPLIED WARRANTY OF MERCHANTABILITY OR FITNESS FOR PARTICULAR PURPOSE.**
  
3. **Remedies:**  
Stoelting’s sole obligations, and Buyer’s sole remedies, for any breach of this warranty shall be the repair or (at Stoelting’s option) replacement of the affected component at Stoelting’s plant in Kiel, Wisconsin, or (again, at Stoelting’s option) refund of the purchase price of the affected equipment, and, during the first twelve (12) months of the warranty period, deinstallation/reinstallation of the affected component from/into the equipment. Those obligations/remedies are subject to the conditions that Buyer (a) signs and returns to Stoelting, upon installation, the Start-Up and Training Checklist for the affected equipment, (b) gives Stoelting prompt written notice of any claimed breach of warranty within the applicable warranty period, and (c) delivers the affected equipment to Stoelting or its designated service location, in its original packaging/crating, also within that period. Buyer shall bear the cost and risk of shipping to and from Stoelting’s plant or designated service location.
  
4. **Exclusions and Limitations:**  
This warranty does not extend to parts, sometimes called “wear parts”, which are generally expected to deteriorate and to require replacement as equipment is used, including as examples but not intended to be limited to o-rings, auger flights, auger seals, auger support bushings, and drive belts. All such parts are sold

**AS IS.**

Further, Stoelting shall not be responsible to provide any remedy under this warranty with respect to any component that fails by reason of negligence, abnormal use, misuse or abuse, use with parts or equipment not manufactured or supplied by Stoelting, or damage in transit.

**THE REMEDIES SET FORTH IN THIS WARRANTY SHALL BE THE SOLE LIABILITY STOELTING AND THE EXCLUSIVE REMEDY OF BUYER WITH RESPECT TO EQUIPMENT SUPPLIED BY STOELTING; AND IN NO EVENT SHALL STOELTING BE LIABLE FOR ANY INCIDENTAL OR CONSEQUENTIAL DAMAGES, WHETHER FOR BREACH OF WARRANTY OR OTHER CONTRACT BREACH, NEGLIGENCE OR OTHER TORT, OR ON ANY STRICT LIABILITY THEORY.**