



**Model E112 / F112**  
**OPERATORS MANUAL**

Manual No. 513613

Rev.6



This manual provides basic information about the machine. Instructions and suggestions are given covering its operation and care.

The illustrations and specifications are not binding in detail. We reserve the right to make changes to the machine without notice, and without incurring any obligation to modify or provide new parts for machines built prior to date of change.

**DO NOT ATTEMPT** to operate the machine until instructions and safety precautions in this manual are read completely and are thoroughly understood. If problems develop or questions arise in connection with installation, operation, or servicing of the machine, contact Stoelting.



[stoeltingfoodservice.com](http://stoeltingfoodservice.com)

Stoelting Foodservice Equipment  
502 Highway 67  
Kiel, WI 53042-1600  
U.S.A.

Main Tel: 800.558.5807  
Fax: 920.894.7029

Customer Service: 888.429.5920  
Fax: 800.545.0662  
Email: [foodservice@stoelting.com](mailto:foodservice@stoelting.com)

© 2014 PW Stoelting, LLC

---

## ***A Few Words About Safety***

### **Safety Information**

**Read and understand the entire manual before operating or maintaining Stoelting equipment.**

This manual provides the operator with information for the safe operation and maintenance of Stoelting equipment. As with any machine, there are hazards associated with their operation. For this reason safety is emphasized throughout the manual. To highlight specific safety information, the following safety definitions are provided to assist the reader.

The purpose of safety symbols is to attract your attention to possible dangers. The safety symbols, and their explanations, deserve your careful attention and understanding. The safety warnings do not by themselves eliminate any danger. The instructions or warnings they give are not substitutes for proper accident prevention measures.

If you need to replace a part, use genuine Stoelting parts with the correct part number or an equivalent part. We strongly recommend that you do not use replacement parts of inferior quality.



### **Safety Alert Symbol:**

**This symbol** Indicates danger, warning or caution. Attention is required in order to avoid serious personal injury. The message that follows the symbol contains important information about safety.

### **Signal Word:**

Signal words are distinctive words used throughout this manual that alert the reader to the existence and relative degree of a hazard.



The signal word “WARNING” indicates a potentially hazardous situation, which, if not avoided, may result in death or serious injury and equipment/property damage.



The signal word “CAUTION” indicates a potentially hazardous situation, which, if not avoided, may result in minor or moderate injury and equipment/property damage.

### **CAUTION**

The signal word “CAUTION” not preceded by the safety alert symbol indicates a potentially hazardous situation, which, if not avoided, may result in equipment/property damage.

### **NOTE (or NOTICE)**

The signal word “NOTICE” indicates information or procedures that relate directly or indirectly to the safety of personnel or equipment/property.

# TABLE OF CONTENTS

<b>Section</b>	<b>Description</b>	<b>Page</b>
<b>1</b>	<b>Description and Specifications</b>	
1.1	Description.....	1
1.2	Specifications .....	2
<b>2</b>	<b>Installation Instructions</b>	
2.1	Safety Precautions .....	5
2.2	Shipment and Transit.....	5
2.3	Machine Installation.....	5
<b>3</b>	<b>Initial Set-Up and Operation</b>	
3.1	Operator's Safety Precautions.....	7
3.2	Operating Controls and Indicators.....	7
3.3	Sanitizing .....	8
3.4	Freeze Down and Operation .....	9
3.5	Mix Information .....	9
3.6	Removing Mix From Machine.....	10
3.7	Cleaning the Machine.....	10
3.8	Disassembly of Machine Parts .....	10
3.9	Cleaning the Machine Parts .....	11
3.10	Sanitize Machine and Machine Parts .....	11
3.11	Assembly of Machine .....	11
3.12	Routine Cleaning .....	12
3.13	Preventative Maintenance .....	12
3.14	Extended Storage.....	15
<b>4</b>	<b>Troubleshooting</b>	
4.1	Light Indicators .....	17
4.2	Troubleshooting.....	17
<b>5</b>	<b>Replacement Parts</b>	
5.1	Decals and Lubrication .....	19
5.2	Auger Shaft and Faceplate Parts .....	20
5.3	Hopper Parts .....	22
5.4	Autofill Options .....	23



## SECTION 1 DESCRIPTION AND SPECIFICATIONS

### 1.1 DESCRIPTION

The Stoelting E112/F112 counter machines are gravity fed. The machines are equipped with fully automatic controls to provide a uniform product. They will operate with almost any type of shake or frozen beverage mix. This manual is designed to help qualified service personnel and operators with the installation, operation and maintenance of the Stoelting E112/F112 gravity machines.



Figure 1-1 Model E112



Figure 1-1 Model F112

## 1.2 SPECIFICATIONS

### E112

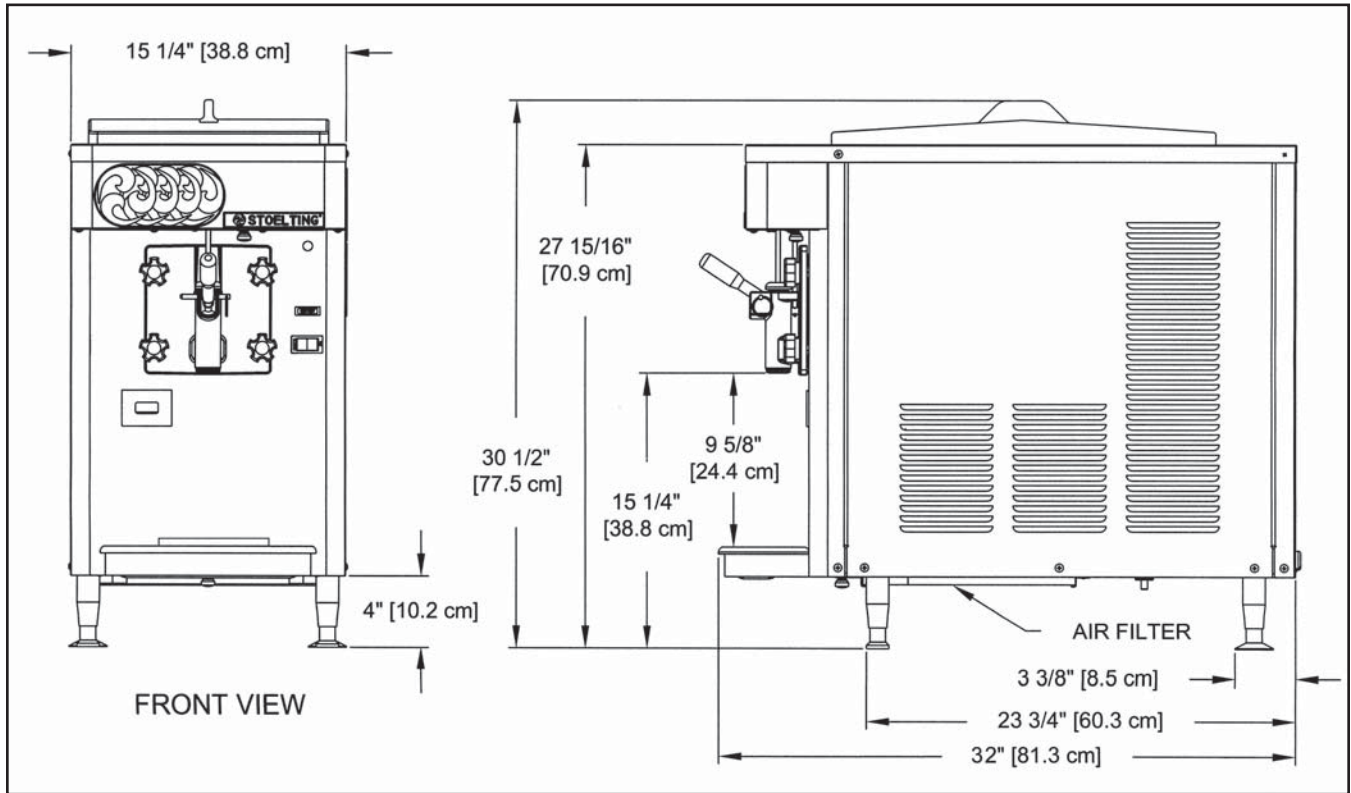

### F112

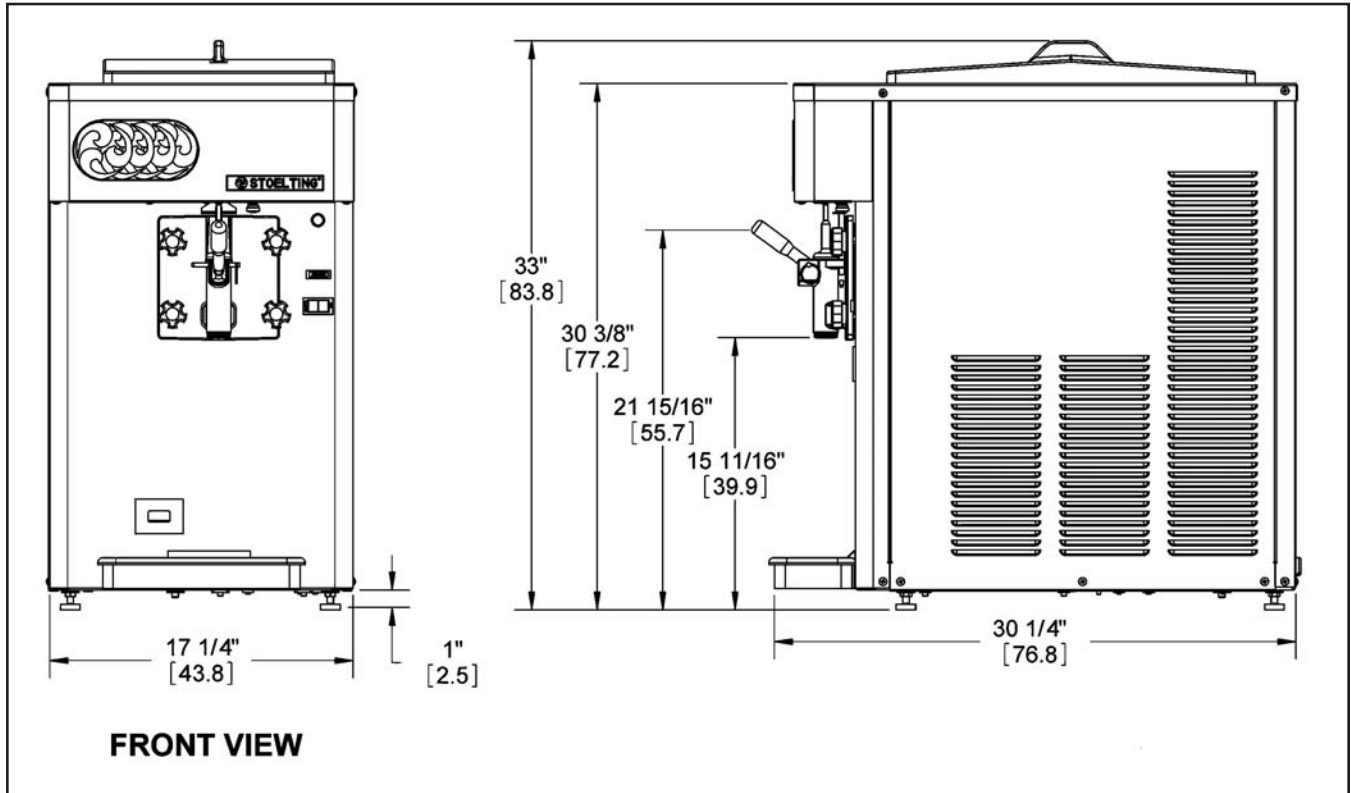

Figure 1-2 Specifications



1.2 SPECIFICATIONS - CONTINUED

	<b>Model E112</b>		<b>Model F112</b>	
	<b>Machine</b>	<b>with crate</b>	<b>Machine</b>	<b>with crate</b>
<b>Dimensions</b>				
width	15-1/4" (38,7 cm)	17-1/2" (44,5 cm)	17-1/4" (43,8 cm)	29" (73,7 cm)
height	30-1/2" (77,5 cm)	35" (88,9 cm)	33" (83,8 cm)	44" (111,8 cm)
depth	32" (81,3 cm)	36-1/2" (92,7 cm)	30-1/4" (76,8 cm)	39" (99,1 cm)
<b>Weight</b>	205 lbs (92,9 kg)	215 lbs (97,5 kg)	288 lbs (130,6 kg)	315 lbs (142,8 kg)
<b>Electrical</b>	<b>1 Phase, 115 VAC, 60Hz</b>		<b>1 Phase, 208-240 VAC, 60Hz</b>	
running amps	16A		10A	
connection type	NEMA5-20P power cord provided		NEMA6-15P power cord provided	
International Option	1 Phase, 220-240 VAC, 50Hz		1 Phase, 220-240 VAC, 50Hz	
<b>Compressor</b>	6,000 Btu/hr		8,600 Btu/hr	
<b>Drive Motor</b>	1/3 hp		3/4 hp	
<b>Air Flow</b>	Air cooled units require 3" (7,6 cm) air space on both sides or 4" (10,2 cm) air space in back for side-by-side installation		Air cooled units require 6" (15,24 cm) air space on both sides	
<b>Plumbing Fittings</b>	N/A		Water cooled units require 3/8" N.P.T. water and drain fittings.	
<b>Hopper Volume</b>	3.625 gallon (13,73 liters)		5.375 gallon (20,35 liters)	
<b>Freezing Cylinder Volume</b>	1.25 gallon (4,73 liters)		2.125 gallon (8,04 liters)	
<b>Production Capacity</b>	18 GPH (68,15 liters)		24 GPH (90,87 liters)	



## SECTION 2 INSTALLATION INSTRUCTIONS

### 2.1 SAFETY PRECAUTIONS

Do not attempt to operate the machine until the safety precautions and operating instructions in this manual are read completely and are thoroughly understood.

Take notice of all warning labels on the machine. The labels have been put there to help maintain a safe working environment. The labels have been designed to withstand washing and cleaning. All labels must remain legible for the life of the machine. Labels should be checked periodically to be sure they can be recognized as warning labels.

If danger, warning or caution labels are needed, indicate the part number, type of label, location of label, and quantity required along with your address and mail to:

**STOELTING, INC.**  
**ATTENTION: Customer Service**  
**502 Hwy. 67**  
**Kiel, Wisconsin 53042**

### 2.2 SHIPMENT AND TRANSIT

The machine has been assembled, operated and inspected at the factory. Upon arrival at the final destination, the entire machine must be checked for any damage which may have occurred during transit.

With the method of packaging used, the machine should arrive in excellent condition. THE CARRIER IS RESPONSIBLE FOR ALL DAMAGE IN TRANSIT, WHETHER VISIBLE OR CONCEALED. Do not pay the freight bill until the machine has been checked for damage. Have the carrier note any visible damage on the freight bill. If concealed damage and/or shortage is found later, advise the carrier within 10 days and request inspection. The customer must place claim for damages and/or shortages in shipment with the carrier. Stoelting, Inc. cannot make any claims against the carrier.

### 2.3 MACHINE INSTALLATION

Installation of the machine involves moving the machine close to its permanent location, removing all crating, setting in place, assembling parts, and cleaning.

- A. Uncrate the machine.
- B. Accurate leveling is necessary for correct drainage of machine barrel and to insure correct overrun. Place a bubble level on top of the machine at each corner to check for level condition. If adjustment is necessary, level the machine by turning the bottom part of each leg in or out.
- C. The F112 has a base gasket that must be installed. Separate the gasket and install it with the seam to the back. Make sure the angled side of the gasket is facing up.



**Figure 2-2 Space and Ventilation Requirements**

- D. Correct ventilation is required. The E112 requires 3" clearance on both sides. If the machine is placed side-by-side next to other equipment, there needs to be at least 4" clearance at the back of the machine. The air-cooled F112 requires 6" clearance on both sides for proper air flow.

#### CAUTION

Failure to provide adequate ventilation will void warranty.

- D. Connect the drip tray bracket by loosening the two screws at the front of the machine. Install the bracket so that it rests on the nylon washer between the two metal washers. Tighten the screws.



**Figure 2-3 Drip Tray Bracket**

- E. The machine leaves the factory with the control board set for slush. Contact a service technician to properly set the machine for shake.

**WARNING**

Do not alter or deform electrical plug in any way. Altering the plug to fit into an outlet of different configuration may cause fire, risk of electrical shock, product damage and will void warranty.

- F. Place the CLEAN-ON-OFF switch in the OFF position.
- E. Connect the power cord to the proper power supply. The plug on the E112 is designed for 115VAC / 20 amp duty and the plug on the F112 is designed for 208-240VAC / 15 amp duty. Check the nameplate on your machine for proper supply. The unit must be connected to a properly grounded receptacle. The electrical cord furnished as part of the machine has a three prong grounding type plug. The use of an extension cord is not recommended, if necessary use one with a size 12 gauge or heavier with ground wire. Do not use an adapter to get around grounding requirement.

## SECTION 3 INITIAL SET-UP AND OPERATION

### 3.1 OPERATOR'S SAFETY PRECAUTIONS

SAFE OPERATION IS NO ACCIDENT; observe these rules:

- A. Know the machine. Read and understand the Operating Instructions.
- B. Notice all warning labels on the machine.
- C. Wear proper clothing. Avoid loose fitting garments, and remove watches, rings or jewelry that could cause a serious accident.
- D. Maintain a clean work area. Avoid accidents by cleaning up the area and keeping it clean.
- E. Stay alert at all times. Know which switch, push button or control you are about to use and what effect it is going to have.
- F. Disconnect electrical cord for maintenance. Never attempt to repair or perform maintenance on the machine until the main electrical power has been disconnected.
- G. Do not operate under unsafe operating conditions. Never operate the machine if unusual or excessive noise or vibration occurs.

### 3.2 OPERATING CONTROLS AND INDICATORS

Before operating the machine, it is required that the operator know the function of each operating control. Refer to Figure 3-1 for the location of the operating controls on the machine.

#### WARNING

High voltage will shock, burn or cause death. The OFF-ON switch must be placed in the OFF position prior to disassembling for cleaning or servicing. Do not operate machine with cabinet panels removed.

#### A. Spigot Switch

The spigot switch will automatically start the auger drive and refrigeration systems when the spigot is opened to dispense product. When the spigot is closed, the drive motor and compressor will remain on until the product in the freezing cylinder reaches the proper consistency..



Figure 3-1 Controls

**B. CLEAN-OFF-ON Switch**

The CLEAN-OFF-ON switch is used to supply power to the control circuit. When the switch is in the OFF (middle) position, power will not be supplied to the control board or refrigeration system. When the switch is in the ON position, the machine will operate in the freezing mode. When the switch is in the CLEAN position, all refrigeration will stop and the auger will start rotating.

**C. ADD MIX Light**

The ADD MIX light will flash to alert the operator to a low mix condition. It does so by monitoring the mix level in the hopper. When the ADD MIX light is flashing, refill hopper immediately.

**NOTE**

*Failure to refill hopper immediately may result in operational problems.*

**D. Diagnostic Light**

The Diagnostic Light will flash if an error occurs. The light will flash once if there is a compressor error. There will be two quick flashes if there is an auger error. And there will be three quick flashes if the machine is left in clean mode for more than 20 minutes. Refer to the troubleshooting section for details.

**E. Consistency Adjustment Screw**

The Consistency Adjustment Screw increases or decreases product consistency. A tension spring is connected to the screw and changes the amount of torque needed to complete a refrigeration cycle. Turn the knob clockwise to increase consistency or counterclockwise to decrease consistency.

**NOTE**

*An additional spring is included with the machine behind the header panel. The additional spring can be installed for use with shake mixes when a higher consistency is required. Do not use the optional spring with slush mixes.*

**F. Front Door Safety Switch**

The front door safety switch prevents the auger from turning when the front door is removed. The switch is open when the door is not in place and closed when the door is properly installed.

**G. Autofill Kit - Optional (E112 Part 2183807, F112 Part 2187101)**

The autofill kit is used with a pump to keep the hopper filled. The autofill kit is for use with non-potentially hazardous food substances; non-dairy. Refer to Section 5-4 for Autofill options.

**H. Light Kit - Optional (E112 Part 2183800, F112 Part 2187102)**

The light kit is installed behind the header panel and illuminates a translucent header panel.

**I. Bottle Rack Kit - Optional (E112 Part 2187100, F112 Part 2187040 or 2187024)**

The bottle rack kit is installed onto the header panel and holds 7 flavor bottles (13 bottles on the 2187024).

**J. Spinner Kit - Optional (E112 Part 2187103, F112 Part 2187031)**

The spinner kit is installed on the front of the machine and offers blended frozen beverages.

**3.3 SANITIZING**

Sanitizing must be done after the machine is cleaned and just before the hopper is filled with mix. Sanitizing the night before is not effective. However, you should always clean the machine and parts after each use.

*The United States Department of Agriculture and the Food and Drug Administration require that all cleaning and sanitizing solutions used with food processing equipment be certified for this use.*

When sanitizing the machine, refer to local sanitary regulations for applicable codes and recommended sanitizing products and procedures. The frequency of sanitizing must comply with local health regulations.

Mix sanitizer according to manufacturer's instructions to provide a 100 parts per million (ppm) strength solution and check the solution with chlorine test strips. Mix sanitizer in quantities of no less than 2 gallons (7.5 liters) of 90° to 110°F (32° to 43°C) water. Allow sanitizer to contact the surfaces to be sanitized for 5 minutes. Any sanitizer must be used only in accordance with the manufacturer's instructions.

**CAUTION**

Do not allow sanitizer to remain in contact with stainless steel parts for prolonged periods. Prolonged contact of sanitizer with machine may cause corrosion of stainless steel parts.

In general, sanitizing may be conducted as follows:

- A. Prepare Stera-Sheen Green Label Sanitizer or equivalent according to manufacturer's instructions to provide a 100 ppm strength solution. Mix the sanitizer in quantities of no less than 2 gallons of 90° to 110°F (32° to 43°C) water. Check the strength of the sanitizing solution. Use a chlorine test strip and color chart to make sure the solution has 100 ppm. Any sanitizer must be used only in accordance with the manufacturer's instructions.

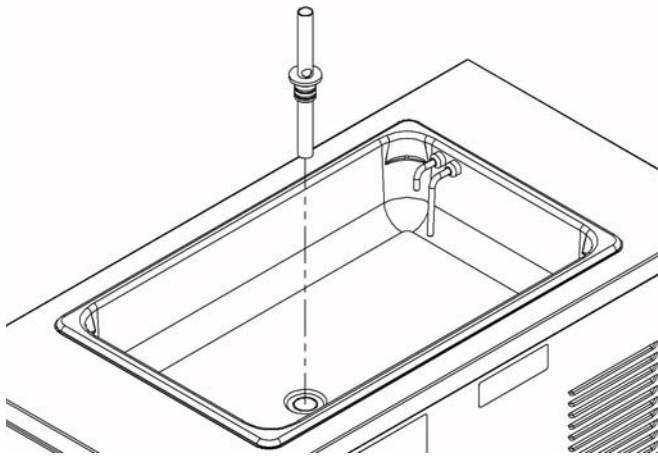

**Figure 3-2 Mix Inlet Regulator**

- B. If using a shake mix, place the mix inlet regulator into hopper (Refer to Figure 3-2). If using a slush mix, the mix inlet regulator is not required.
- C. Pour the sanitizing solution into the hopper and place the switch in the CLEAN position. Check for leaks.
- D. Clean sides of hopper, mix inlet regulator and underside of hopper cover using a soft bristle brush dipped in the sanitizing solution (Refer to Figure 3-3).



**Figure 3-3 Sanitizing hopper**

- E. After five minutes, place a bucket under the spigot and open spigot to drain most sanitizing solution. Leave a small amount of the sanitizing solution in the freezing cylinder. Place the switch in the OFF (middle) position.
- F. Collect the remaining sanitizing solution in a cup and test the chlorine contents with a new test strip. A reading of 100 ppm or more is acceptable.  
If the reading is less than 100 ppm, sanitize the machine again.  
If the reading is less than 100 ppm after sanitizing the second time, disassemble and wash the machine again.

### 3.4 FREEZE DOWN AND OPERATION

This section covers the recommended operating procedures for the safe operation of the machine.

- A. Sanitize just prior to use.
- B. Place the switch in the OFF (middle) position.

#### NOTE

*Make sure the mix inlet regulator is in place before adding shake mixes. This is not necessary for slush mixes.*

- C. Pour approximately 1/2 gallon of fully thawed mix into the hopper. Open spigot and drain a small amount of mix to remove any remaining sanitizer.
- D. Fill the hopper with pre-chilled (40°F or 4°C) mix.

#### NOTE

*Do not overfill the hopper. Mix level must be below the air inlet tube on the mix inlet regulator.*

- E. Place the switch in the ON position.

#### NOTE

*After the drive motor starts, there is a 3 or 4 second delay before the compressor starts.*

- F. After 8 to 12 minutes the product will be at consistency and will be ready to serve. Freeze down time may vary depending on mix type and ambient temperatures.
- G. To dispense, pull the spigot handle down to open the spigot.
- H. The machine is designed to dispense the product at a reasonable draw rate. If the machine is overdrawn, the result is a soft product or a product that will not dispense at all. If this should occur, allow the machine to run for approximately 30 seconds before dispensing additional product.
- I. Do not operate the machine when the ADD MIX light is on. Refill the hopper immediately.

### 3.5 MIX INFORMATION

Mix can vary considerably from one manufacturer to another. Differences in the amount of butterfat content and quantity and quality of other ingredients have a direct bearing on the finished frozen product. A change in machine performance that cannot be explained by a technical problem may be related to the mix.

Proper product serving temperature varies from one manufacturer's mix to another. Shake and stackable slush mixes provide satisfactory product from 24° to 28°F (-4° to -2°C).

When checking the temperature, stir the thermometer in the frozen product to obtain an accurate reading.

Old mix or mix that has been stored at elevated temperatures will produce poor-quality product with a bad taste and unacceptable appearance. To retard bacteria growth in dairy based mixes, the best storage temperature range is between 33° to 38°F (0.5° to 3.3°C).

Some shake mixes tend to foam more than others. If foam appears in the hopper, skim off with a sanitized utensil and discard. Periodically, stir the mix in the hopper with a sanitized utensil to help prevent excess foam.

### 3.6 REMOVING MIX FROM MACHINE

To remove the mix from the machine, refer to the following steps:

- A. If removing shake mix, pull the mix inlet regulator straight up and remove it from the hopper.
- B. Place the switch in the CLEAN position to rotate the auger. Allow the mix to agitate in freezing cylinder until the mix has become liquid, about 5 minutes.
- C. Drain the liquid mix by opening the spigot. A container should be placed under the spigot to collect the liquid mix.
- D. Place the switch in the OFF (middle) position.

### 3.7 CLEANING THE MACHINE

#### NOTE

*The frequency of cleaning the machine and machine parts must comply with local health regulations.*

After the mix has been removed from the machine, the machine must be cleaned. To clean the machine, refer to the following steps:

- A. Close the spigot and fill the hopper with 2 gallons (8 liters) of tap water.
- B. Place the switch in the CLEAN position. The auger will start to rotate.
- C. Allow the water to agitate for approximately 30 seconds.
- D. Open the spigot to drain the water. Remember to place a container under the spigot to catch the water. When the water has drained, place the switch in the OFF (middle) position. Allow the freezing cylinder to drain completely.
- E. Prepare sanitizing solution according to manufacturer's instructions to provide a 100 ppm strength solution. Mix the sanitizer in quantities of no less than 2 gallons of 90° to 110°F (32° to 43°C) water. Check the strength of the sanitizing solution. Use a chlorine test strip and color chart to make sure the solution has 100 ppm. Repeat steps A through D using the sanitizing solution.

### 3.8 DISASSEMBLY OF MACHINE PARTS

Inspection for worn or broken parts should be made each time the machine is disassembled. All worn or broken parts should be replaced to ensure safety to both the operator and the customer and to maintain good machine performance and a quality product. Frequency of cleaning must comply with the local health regulations.

To disassemble the machine, refer to the following steps:

 <b>CAUTION</b>
<b>Hazardous Moving Parts.</b> Revolving auger shaft can grab and cause injury. Place the switch in the OFF (middle) position before disassembling for cleaning or servicing.

- A. Remove hopper cover. Remove the mix inlet regulator from the hopper (if installed).
- B. Pull out the spigot pin by its ring (Refer to Figure 3-4).

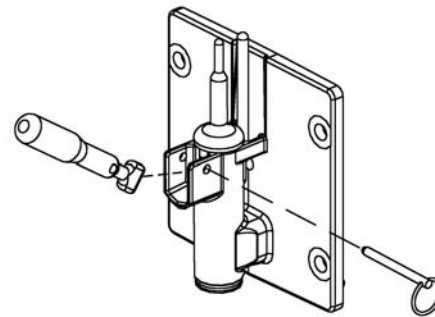

**Figure 3-4 Remove Spigot Pin**

- C. Remove the spigot handle.
- D. Remove front door by turning the circular knobs and then pulling door off the studs.

#### NOTE

*When removing front door, entire door and stator assembly will come out as well.*

- E. Remove torque rod from stator assembly.
- F. Remove quad ring from groove in front door.
- G. Remove stator bar. Remove o-ring and white bushing from stator bar.
- H. Remove auger support bushing.
- I. Turn the spigot body until the ice breaker bar can be removed. Remove breaker bar (Refer to Figure 3-5).



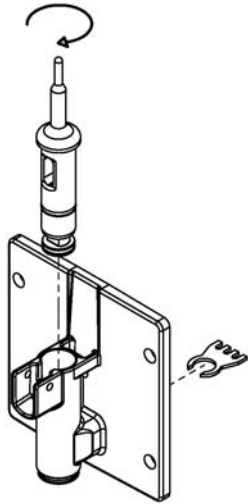

**Figure 3-5 Spigot and Ice Breaker Bar Removal**

- J. Remove spigot body from the front door.
- K. Remove o-rings (2) from the spigot by first wiping off the lubricant using a clean paper towel. Then squeeze the o-ring upward with a dry cloth. When a loop is formed, roll the o-ring out of the groove (Refer to Figure 3-6).
- L. Remove auger assembly from the freezing cylinder and remove auger blades.
- M. Remove rear seal and o-ring from auger.
- N. Remove drain tray, drip tray and drip tray grid.



**Figure 3-6 Removing O-Ring**

### 3.9 CLEANING AND SANITIZING THE MACHINE PARTS

Place all loose parts in a pan or container and take to the wash sink for cleaning. Local and state health codes dictate the procedure required. Some health codes require a four-sink process (pre-wash, wash, rinse, sanitize, and air-dry), while other codes require a three-sink process (without the pre-wash step). The following procedures are a general guideline only. Consult your local and state health codes for procedures required in your location.



**Figure 3-7 Cleaning Freezing Cylinder**

- A. Prepare Stera-Sheen or equivalent cleaner in 2 gallons of 90° to 110°F (32° to 43°C) water following manufacturers instructions.
- B. Prepare sanitizing solution according to manufacturer's instructions to provide a 100 ppm strength solution. Mix the sanitizer in quantities of no less than 2 gallons of 90° to 110°F (32° to 43°C) water. Check the strength of the sanitizing solution. Use a chlorine test strip and color chart to make sure the solution has 100 ppm.
- D. Place all parts in the cleaning solution and clean the parts with the provided brushes. Rinse all parts with clean 90° to 110°F (32° to 43°C) water. Place the parts in the sanitizing solution.
- E. Wash the hopper and freezing cylinder with the 90° to 110°F (32° to 43°C) cleaning solution and brushes provided (Refer to Figure 3-7).
- F. Clean the rear seal surfaces from the inside of the freezing cylinder with the 90° to 110°F (32° to 43°C) cleaning solution.

### 3.10 SANITIZE MACHINE

#### CAUTION

Do not allow sanitizer to remain in contact with stainless steel parts for prolonged periods. Prolonged contact of sanitizer with machine may cause corrosion of stainless steel parts.

- A. Use Stera-Sheen or equivalent sanitizing solution mixed according to manufacturer's instructions to provide 100 parts per million strength solution. Mix sanitizer in quantities of no less than 2 gallons (7.5 liters) of 90° to 110°F (32° to 43°C) water. Any sanitizer must be used only in accordance with the manufacturer's instructions.

- B. With the large brush provided, sanitize the rear of the freezing cylinder by dipping the brush in the sanitizing solution and brushing the rear of the cylinder.

### 3.11 ASSEMBLY OF MACHINE

To assemble the machine parts, refer to the following steps:

#### NOTE

*Petrol Gel sanitary lubricant or equivalent must be used when lubrication of parts is specified.*

#### NOTE

*The United States Department of Agriculture and the Food and Drug Administration require that lubricants used on food processing equipment be certified for this use. Use lubricants only in accordance with the manufacturer's instructions.*

- A. Assemble all o-rings onto the parts dry, without lubrication. Then apply a thin film of sanitary lubrication to the exposed surfaces of the o-rings. Also apply a thin film of sanitary lubricant to the inside and outside of the front auger support bushing, and to the inside and outside of stator support bushing.
- B. Assemble the rear seal onto the auger with the large end to the rear. Be sure the o-ring is in place before installing the rear seal (Refer to Figure 3-8).
- C. Put a small amount of spline lubricant on the hex end of the auger shaft. A small container of spline lubricant is shipped with the machine.

- D. Install the plastic auger blade onto the auger.
- E. Push the auger into the freezing cylinder and rotate it slowly until the auger engages the drive shaft.
- F. Insert the spigot body into the front door.

#### NOTE

*Press the o-rings against the spigot body when inserting it into the front door to prevent damage.*

- G. Turn the spigot body until the ice breaker bar can be inserted. Insert the breaker bar and rotate the spigot body 90°.
- H. Install the auger support bushing onto the front door so the beveled edge of the bushing is against the door.
- I. Install the white stator support bushing onto the rear of the stator bar and insert stator into spigot.
- J. Insert the torque rod. The rod should be placed through the hole in the stator bar.
- K. Install the front door onto the machine.

#### NOTE

*When installing the door onto the machine, the torque rod must be placed in the center of the metal torque actuator arm*

- L. Install the knobs on the machine studs.
- M. Look for the proper seal between the freezing cylinder, quad ring, and front door

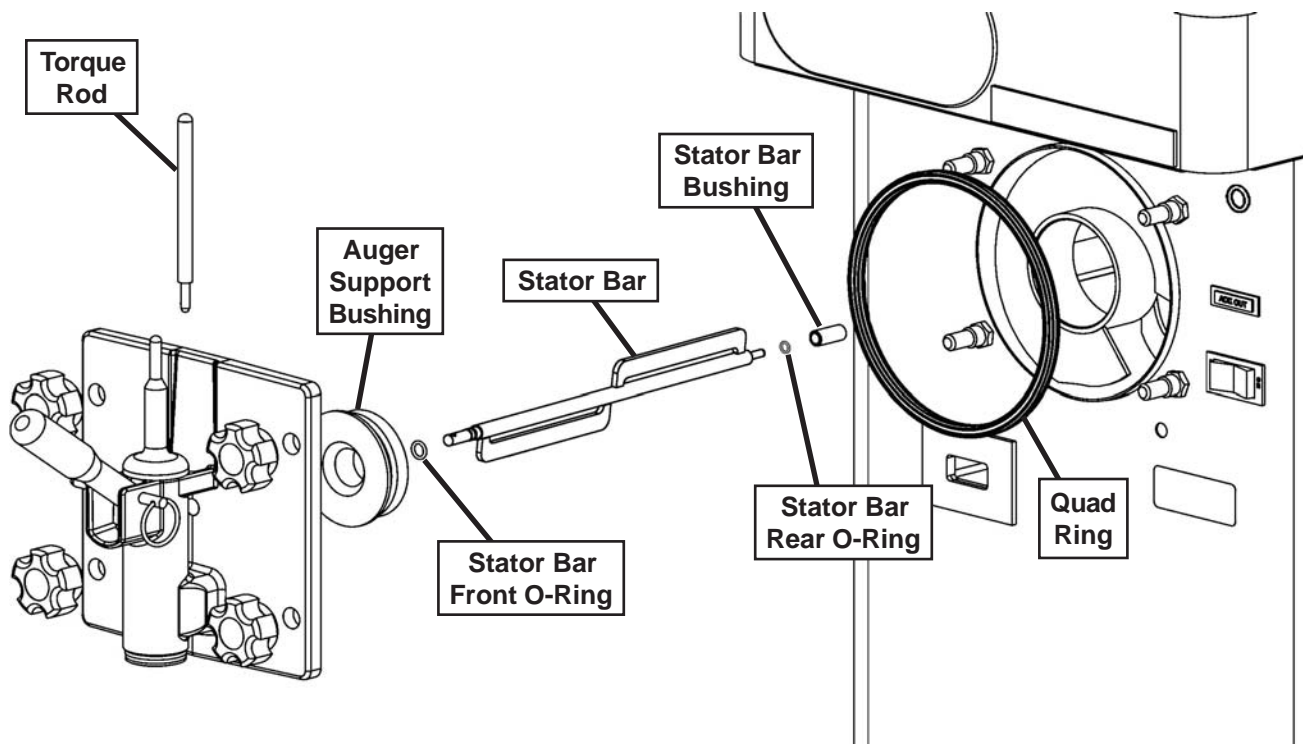

Figure 3-9 Door and Stator Assembly

## CAUTION

Do not place the mix inlet regulator into the hopper before installing the auger. Attempting to install the auger with the mix inlet regulator in place will damage the regulator.

- N. Insert the spigot handle so the hole lines up and insert the spigot pin.
- O. Install the mix inlet regulator into the hopper if using shake mix. If using slush mix, the mix inlet regulator is not required.
- P. Install the hopper cover, drain tray, drip tray, and drip tray grid.

### 3.12 ROUTINE CLEANING

To remove spilled or dried mix from the machine exterior, wash in the direction of the finish with warm soapy water and wipe dry. Do not use highly abrasive materials as they will mar the finish.

### 3.13 PREVENTIVE MAINTENANCE

Stoelting recommends that a maintenance schedule be followed to keep the machine clean and operating properly.

#### CLEANING AND SANITIZING INFORMATION

Special consideration is required when it comes to food safety and proper cleaning and sanitizing.

The following information has been compiled by Purdy Products Company, makers of Stera-Sheen Green Label Cleaner/Sanitizer and specifically covers issues for cleaning and sanitizing frozen dessert machines. This information is meant to supplement a comprehensive food safety program.

#### SOIL MATERIALS ASSOCIATED WITH FROZEN DESSERT MACHINES

**MILKFAT/BUTTERFAT** – As components of ice-cream/frozen custard mix, these soils will accumulate on the interior surfaces of the machine and its parts. Fats are difficult to remove and help attribute to milkstone build-up.

**MILKSTONE** – Is a white/gray film that forms on equipment and utensils that come in contact with dairy products. These films will accumulate slowly on surfaces because of ineffective cleaning, use of hard water, or both. Milkstone is usually a porous deposit, which will harbor microbial contaminants and eventually defy sanitizing efforts.

Once milkstone has formed, it is very difficult to remove. Without using the correct product and procedure, it is nearly impossible to remove a thick layer of milkstone. (NOTE: general-purpose cleaners DO NOT remove milkstone.) This can lead to high bacteria counts and a food safety dilemma.

**IT IS BEST TO CONTROL MILKSTONE ON A DAILY BASIS BEFORE IT CAN BECOME A SIGNIFICANT FOOD SAFETY PROBLEM.**

In addition to food safety, milkstone can cause premature wear to machine parts which can add to costs for replacement parts or possibly more expensive repairs if worn machine parts are not replaced once they have become excessively worn.

#### IMPORTANT DIFFERENCES BETWEEN CLEANING AND SANITIZING

##### CLEANING vs. SANITIZING

It is important to distinguish between cleaning and sanitizing. Although these terms may sound synonymous, they are not. BOTH are required for adequate food safety and proper machine maintenance.

##### CLEANING

- Is the removal of soil materials from a surface.
- Is a prerequisite for effective sanitizing.

##### NOTE

*An UNCLEAN surface will harbor bacteria that can defy sanitizing efforts.*

Bacteria can develop and resist sanitizing efforts within a layer of soil material (milkstone). Thorough cleaning procedures that involve milkstone removal are critical for operators of frozen dessert machines.

##### SANITIZING

- Kills bacteria.
- Can be effective on clean surfaces only.

##### NOTE

*Using a SANITIZER on an unclean surface will not guarantee a clean and safe frozen dessert machine.*

#### PROPER DAILY MAINTENANCE: THE ONLY WAY TO ASSURE FOOD SAFETY AND PRODUCT QUALITY

Proper daily maintenance can involve a wide variety of products and procedures. Overall, the products and procedures fall into three separate categories. (Please note that this is a brief overview intended for informational purposes only.)

1. **CLEANING** – This involves draining mix from the freezing cylinder and rinsing the machine with water. Next, a cleaner is run through the machine. Then, the machine is disassembled and removable parts are taken to the sink for cleaning.
2. **MILKSTONE REMOVAL** – Since almost all cleaners do not have the ability to remove milkstone, the use of a delimer becomes necessary. Although this procedure may not be needed on a daily basis, it will usually follow the cleaning procedure. It requires letting a delimer solution soak in the machine for an extended period of time. Individual parts are also soaked in a deliming solution for an extended period of time (more about delimers in Additional Information).

3. **SANITIZING** – After the machine has been cleaned and contains no milkstone, the machine is reassembled. Then a FDA-approved sanitizing solution is run through the machine to kill bacteria. The machine is then ready for food preparation.

As a recommended cleaner and sanitizer for your frozen dessert machine, STERA-SHEEN has proven to be one of the best daily maintenance products for:

- **CLEANING** – Thorough removal of all solids including butterfat and milk fat.
- **MILKSTONE REMOVAL** – Complete removal of milkstone.
- **SANITIZING** – FDA-approved no rinse sanitizer for food contact surfaces.

### ADDITIONAL INFORMATION

#### THE USE OF DELIMERS

A delimer is a strong acid that has the ability to dissolve milkstone. This type of chemical may become necessary once high levels of milkstone have developed. While these products are very effective for removing HIGH levels of milkstone, they are not ideal for two reasons:

1. **PRODUCT SAFETY** – Strong acids are dangerous chemicals and handling them requires safety
2. **MACHINE DAMAGE** – Strong acids will attack metal and rubber causing premature wear of parts. The use of a delimer needs to be closely monitored to avoid damage to machine surfaces and parts.

With proper daily use of STERA-SHEEN or its equivalent, there is no need for the use of a DELIMER.

#### DO NOT USE BLEACH

- **BLEACH HAS ABSOLUTELY NO CLEANING PROPERTIES.**
- **BLEACH IS CORROSIVE.** It can and will damage components of the machine causing premature wear and metal corrosion.

#### GENERAL PURPOSE CLEANERS

General purpose cleaners do not have the ability to remove milkstone. Milkstone will become a problem if not remedied with additional products and procedures.

#### THE USE OF CHLORINE TEST STRIPS

“Test strips” are used to determine concentrations of active chlorine in sanitizing solutions. To use the strips, tear off a small portion and submerge it into the sanitizing solution. Then, compare the color change to the color key on the side of the test strip dispenser to determine the approximate chlorine concentration.

The ideal concentration of chlorine needs to be 100 ppm (as stated by the FDA).

### NOTE

*Follow the directions on the container for proper concentration.*

There are two main factors that contribute to falling chlorine concentrations in a sanitizing solution.

1. **PRODUCT USE** – As the chlorine in the solution is being used, chlorine concentrations fall.
2. **TIME** – As time passes, small amounts of chlorine “evaporate” from the solution. (That is why you can smell it.)

Sanitizing solutions should not be allowed to fall below 100 ppm chlorine. New solutions should be mixed once old solutions become ineffective

#### B. DAILY

1. The exterior should be kept clean at all times to preserve the luster of the stainless steel. A mild alkaline cleaner is recommended. Use a soft cloth or sponge to apply the cleaner.

#### C. WEEKLY

1. Check o-rings and rear seal for excessive wear and replace if necessary.
2. Remove the drip tray by gently lifting up to disengage from the support and pulling out. Clean behind the drip tray and front of the machine with a soap solution.

#### D. QUARTERLY

##### Air Cooled

The air-cooled condenser is a copper tube and aluminum fin type. Condensing is totally dependent upon airflow. A plugged condenser filter, condenser, or restrictions in the louvered panel will restrict airflow. This will lower the capacity of the system and damage the compressor.

The condenser must be kept clean of dirt and grease. The F112 must have a minimum of 6” (15.2 cm) ventilation on the right and left sides of the unit for free flow of air. The E112 must have 3” (7.6 cm) ventilation. Make sure the machine is not pulling over 100° F (37° C) air from other equipment in the area.

The condenser and condenser filter require periodic cleaning. To clean, refer to the following procedures.

##### E112 Air Cooled Condenser Cleaning

- A. Unscrew the knob located on the underside of the machine towards the front (Fig. 3-10).
- B. Remove the filter bracket and remove the filter.
- C. Visually inspect the condenser filter for dirt.
- D. If the filter is dirty, vacuum or brush clean, rinse with clean water and allow to dry before replacing on the machine.

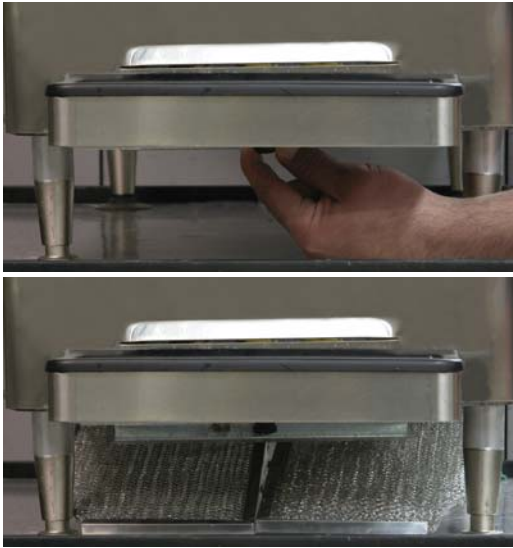

**Figure 3-10 E112 Condenser Filter Removal**

**NOTE**

*If the condenser is not kept clean, refrigeration efficiency will be lost.*

**F112 Air Cooled Condenser Cleaning**

- A. Remove the Phillips head screws from the bottom of the right side panel, and then slide the panel down and out.
- B. To remove the condenser filter, grasp the top and pull off. Visually inspect it for dirt. If the filter is dirty, shake or brush excess dirt off the filter and wash it in warm, soapy water. Once the filter is clean rinse thoroughly in warm, clear water and shake dry, taking care not to damage the filter in any way (Fig. 3-11).



**Figure 3-11 F112 Condenser Filter Removal**

- C. Visually inspect the condenser for dirt by shining a light through the coil from the back (inside) of the condenser.
- D. If the condenser is dirty, place a wet towel over the front (outside) of the condenser.
- E. Using a vacuum, carefully clean the condenser coil from the inside and outside of the machine. A stiff bristled brush may help in releasing debris from between the condenser coils.

**Water Cooled (F112 only)**

The water-cooled condenser is a tube and shell type. The condenser needs a cool, clean supply of water to properly cool the machine. Inlet and discharge lines must be 3/8" I.D. minimum. Make sure the machine is receiving an unrestricted supply of cold, clean water.

**E. SEMI-ANNUALLY**

- 1. Disconnect the machine from the power source.
- 2. Use a Burroughs Belt Tension Gauge to set the tension for the drive belt. Set the belt tension on the E112 to 5-15 lbs and on the F112 to 30-40 lbs.
- 3. Lubricate the condenser fan motor with S.A.E. 20 weight oil. Three to six drops are required.

**3.14 EXTENDED STORAGE**

Refer to the following steps for storage of the machine over any long period of shutdown time:

- A. Place the CLEAN-OFF-ON switch in the OFF (middle) position.
- B. Disconnect (unplug) from the electrical supply source.
- C. Clean all parts that come in contact with mix thoroughly with a warm water cleaning solution. Rinse in clean water and dry parts. Do not sanitize.

**NOTE**

*Do not let the cleaning solution stand in the hopper or in the freezing cylinder during the shutdown period.*

- D. Remove, disassemble and clean the front door, mix inlet regulator and auger parts.
- E. In a water cooled machine, disconnect the water lines and drain water. With a flathead screwdriver, hold the water valve open and use compressed air to clear the lines of any remaining water.



## SECTION 4 TROUBLESHOOTING

### 4.1 LIGHT INDICATORS

The machine has two lights that will alert the user if a problem occurs: an ADD MIX light and a Diagnostic Light.

The ADD MIX light will flash to alert the operator to a low mix condition. It does so by monitoring the mix level in the hopper. When the ADD MIX light is flashing, refill hopper immediately.

The Diagnostic Light will flash if an error occurs. Refer to the chart below for details.

Indication	On	One Blink	Two Blinks	Three Blinks
<b>Conditions</b>	Defrost Mode	Torque is not met after 20 minutes (22 minutes for shake)	Drive current is not sensed	Machine left in clean mode for over 20 minutes
<b>Self Correction</b>	N/A	N/A	The machine attempts to sense drive current with a 3 second pre-stir. If current is sensed, the machine will return to normal operation. If current is not sensed, the machine will wait 7 minutes and try to sense current with another 3 second pre-stir. After the third attempt, the compressor will run on timers.	N/A
<b>Operation</b>	Every 7 minutes the auger will run for 90 seconds.	Timers or until torque switch remains closed for 3 seconds.	Timers	Off
<b>Corrective Action</b>	N/A	Contact Service Technician	Contact Service Technician	Turn CLEAN-OFF-ON switch to OFF (middle) position then turn the switch to ON.

### 4.2 TROUBLESHOOTING

PROBLEM	POSSIBLE CAUSE	REMEDY
<b>Machine does not run.</b>	<ol style="list-style-type: none"> <li>1. Power to machine is off.</li> <li>2. Blown fuse or tripped circuit.</li> <li>3. Freeze-up (auger will not turn).</li> <li>4. High pressure cut-out tripped.</li> <li>5. Front door not in place.</li> </ol>	<ol style="list-style-type: none"> <li>1. Supply power to machine.</li> <li>2. Replace or reset.</li> <li>3. Turn CLEAN-OFF-ON switch to OFF (middle) position for 15 minutes, then restart.</li> <li>4. Wait until automatic reset for machine to start.</li> <li>5. Assemble front door in place.</li> </ol>
<b>Machine will not shut off.</b>	<ol style="list-style-type: none"> <li>1. Drive belt failure.</li> <li>2. Consistency temperature setting is too firm.</li> <li>3. Refrigeration problem.</li> </ol>	<ol style="list-style-type: none"> <li>1. Replace drive belt.</li> <li>2. Turn Consistency Adjustment knob counter-clockwise.</li> <li>3. Check system. (Call distributor for service)</li> </ol>
<b>Product is too firm.</b>	<ol style="list-style-type: none"> <li>1. Consistency temperature setting is too firm.</li> </ol>	<ol style="list-style-type: none"> <li>1. Turn Consistency Adjustment knob counter-clockwise.</li> </ol>

## 4.2 TROUBLESHOOTING - CONTINUED

PROBLEM	POSSIBLE CAUSE	REMEDY
<b>Product is too soft.</b>	<ol style="list-style-type: none"> <li>1. No vent space for free flow of cooling air.</li> <li>2. Air temperature entering condenser is above 100°F.</li> <li>3. Condenser is dirty.</li> <li>4. Consistency setting too soft.</li> <li>5. Stabilizers in mix are broken down.</li> <li>6. Auger is assembled incorrectly.</li> <li>7. Refrigeration problem.</li> </ol>	<ol style="list-style-type: none"> <li>1. A minimum of 6" of vent space required (E112 - 3"). (See Section 2)</li> <li>2. Change location or direct hot air away from machine.</li> <li>3. Clean. (See Section 3)</li> <li>4. Turn Consistency Adjustment knob clockwise.</li> <li>5. Remove mix, clean, sanitize and freeze down with fresh mix.</li> <li>6. Remove mix, clean, reassemble, sanitize and freeze down.</li> <li>7. Check system. (Call distributor for service)</li> </ol>
<b>Product does not dispense.</b>	<ol style="list-style-type: none"> <li>1. No mix in hopper.</li> <li>2. Mix inlet regulator tube is plugged.</li> <li>3. Drive motor overload tripped.</li> <li>4. Drive belt failure.</li> <li>5. Freeze-up (Auger will not turn).</li> </ol>	<ol style="list-style-type: none"> <li>1. Fill hopper with mix.</li> <li>2. Unplug, using small sanitized brush.</li> <li>3. Wait for automatic reset. (If condition continues, call distributor for service.)</li> <li>4. Replace drive belt.</li> <li>5. Turn CLEAN-OFF-ON switch to OFF (middle) position for 15 minutes, then restart.</li> </ol>
<b>Drive belt slipping or squealing.</b>	<ol style="list-style-type: none"> <li>1. Worn drive belt.</li> <li>2. Freeze-up (Auger will not turn).</li> <li>3. Not tensioned properly</li> </ol>	<ol style="list-style-type: none"> <li>1. Replace drive belt.</li> <li>2. Turn CLEAN-OFF-ON switch to OFF (middle) position for 15 minutes, then restart.</li> <li>3. Adjust belt tension</li> </ol>
<b>Low overrun.</b>	<ol style="list-style-type: none"> <li>1. Auger is assembled incorrectly.</li> <li>2. Mix inlet regulator missing.</li> <li>3. Mix inlet regulator o-ring missing.</li> <li>4. Mix inlet regulator air tube blocked.</li> <li>5. Product breakdown.</li> </ol>	<ol style="list-style-type: none"> <li>1. Remove mix, clean, sanitize, and freeze down with fresh mix.</li> <li>2. Replace mix inlet regulator.</li> <li>3. Replace mix inlet regulator o-ring.</li> <li>4. Clean with sanitized brush.</li> <li>5. Fill machine with fresh product.</li> </ol>
<b>Rear auger seal leaks.</b>	<ol style="list-style-type: none"> <li>1. Outside surface of rear auger seal is lubricated.</li> <li>2. Rear seal missing or damaged.</li> <li>3. Seal o-ring missing, damaged or installed incorrectly.</li> <li>4. Worn or scratched auger shaft.</li> </ol>	<ol style="list-style-type: none"> <li>1. Clean lubricant from outside of rear seal, lubricate inside of seal and reinstall.</li> <li>2. Check or replace.</li> <li>3. Check. or replace.</li> <li>4. Replace auger shaft.</li> </ol>
<b>Front door leaks.</b>	<ol style="list-style-type: none"> <li>1. Front door knobs are loose.</li> <li>2. Spigot parts are not lubricated.</li> <li>3. Chipped or worn spigot o-rings.</li> <li>4. O-rings or spigot installed wrong.</li> <li>5. Inner spigot hole in front door nicked or scratched.</li> </ol>	<ol style="list-style-type: none"> <li>1. Tighten knobs.</li> <li>2. See Section 3.</li> <li>3. Replace o-rings.</li> <li>4. Remove spigot and check o-ring.</li> <li>5. Replace front door.</li> </ol>



## SECTION 5 REPLACEMENT PARTS

### 5.1 DECALS AND LUBRICATION

Part	Description	Quantity	
		E112	F112
208135	Brush - 4" X 8" X 16" (Barrel)	1	1
208380	Brush - 1/4" X 3" X 14"	1	1
208401	Brush - 1" X 3" X 10"	1	1
324105	Decal - Caution Electrical Shock	1	1
324106	Decal - Caution Electrical Wiring Materials	1	1
324107	Decal - Caution Hazardous Moving Parts	1	1
324141	Decal - Caution Rotating Blades	1	1
324208	Decal - Attention Refrigerant Leak Check	1	1
324393	Decal - Stoelting Swirl Logo	1	1
324509	Decal - Cleaning Instructions	1	1
324548	Decal - Adequate Ventilation 6"		1
324566	Decal - Wired According To	1	1
324584	Decal - Adequate Ventilation 3"	1	
324686	Decal - Danger Automatic Start	1	1
324804	Decal - Domed Stoelting Swirl (Header Panel)	1	1
324852	Decal - Clean Condenser Filter	1	
324864	Decal - A&W Logo	-	-
324865	Decal - Standby Light	1	1
508048	Lubricant - Spline (2 oz Squeeze Tube)	1	1
508135	Petrol Gel - 4 oz Tube	1	1

## 5.2 AUGER SHAFT AND FACEPLATE PARTS

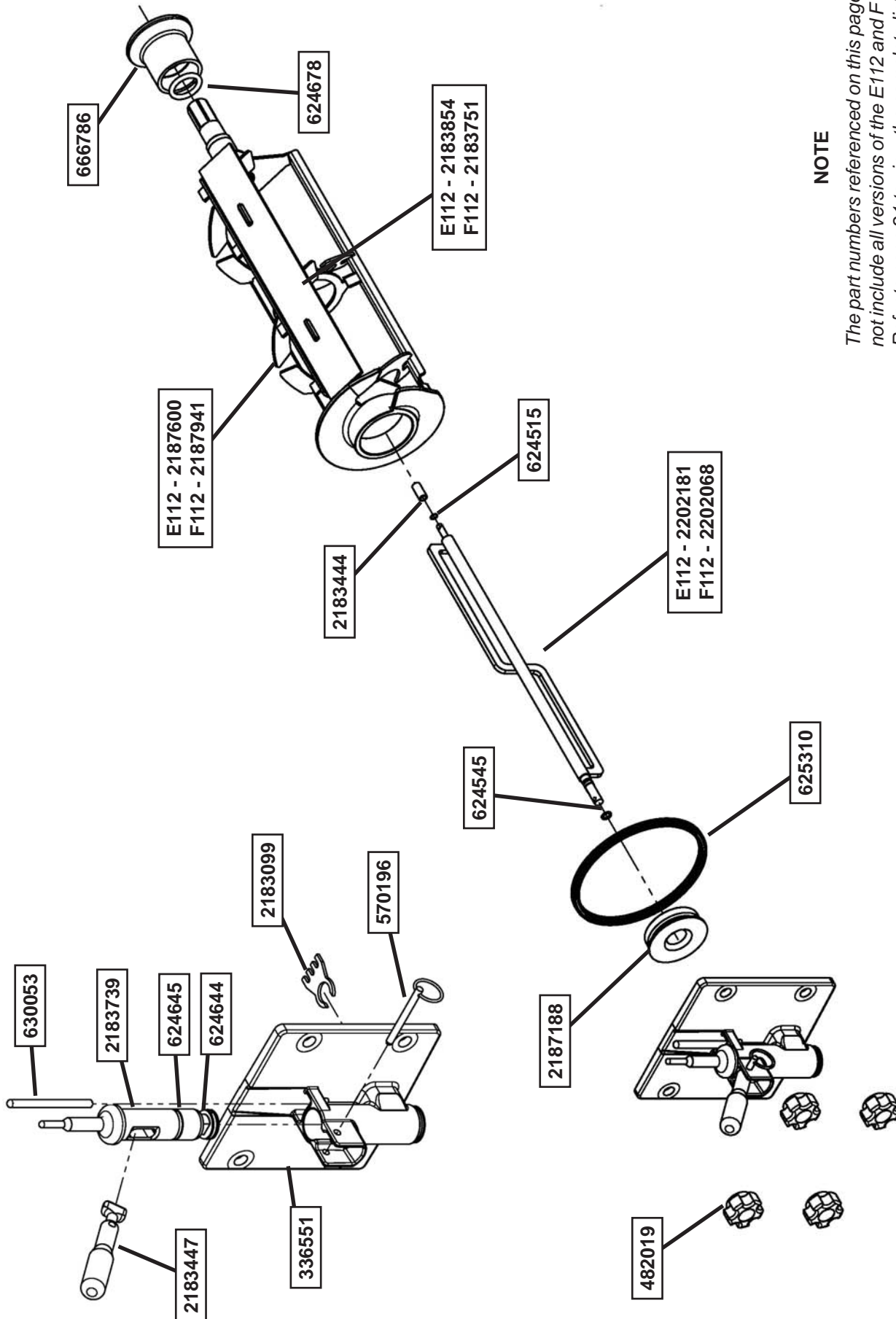

### NOTE

The part numbers referenced on this page do not include all versions of the E112 and F112. Refer to page 21 to view the complete listing.

5.2 AUGER SHAFT AND FACEPLATE PARTS - CONTINUED

Part	Description	Quantity	
		E112	F112
162165	Blade - Scraper (E112 Ser. #22768 - #23376)	2	
336546	Door - Front (E112 - Ser. #0 - #23494)	1	
336551	Door - Front (E112 - Ser. #23495 Plus) (F112 - All)	1	1
482019	Knob - Front Door (Black)	4	4
570196	Pin - Cotterless Clevis (Front Door)	1	1
624515-5	O-Ring - Stator Bar Rear (5 Pack)	1	1
624545-5	O-Ring - Stator Bar Front (5 Pack)	1	1
624644-5	O-Ring - Spigot Body (Bottom) (5 Pack)	1	1
624645-5	O-Ring - Spigot Body (Top) (5 Pack)	1	1
624678-5	O-Ring - Rear Seal - Black (5 Pack)	1	1
625310	Quad-Ring - Front Door - Black	1	1
630053	Rod - Torque Actuator	1	1
666786	Seal - Rear Auger - Black	1	1
2183099	Breaker Bar - Spigot Body	1	1
2183100	Blade - Scraper (E112 - Ser. #0 - #22767)	2	
2183444	Bushing - Stator Support (Rear)	1	1
2183446	Spigot Body (E112 - Ser. #0 - #23197)	1	1
2183447	Handle Only - Spigot	1	1
2183449	Bushing - Front Auger Support (F112 - Ser. #0 - #25280)		1
2183645	Rod Actuator - Spigot (E112 - Ser. #0 - #22767)	1	
2183739	Spigot Body (E112 - Ser. #23198 Plus) (F112 - All)	1	1
2183751	Blade - Scraper		1
2183854	Blade - Scraper (E112 - Ser. #23377 Plus)	1	
2187188	Bushing - Front Auger Support (E112 - All) (F112 - Ser. #25281 Plus)	1	1
2187225	Auger Shaft (F112 - Ser. #0 - #25280)		1
2187600	Auger Shaft	1	
2187941	Auger Shaft		1
2202068	Stator Bar		1
2202181	Stator Bar	1	

### 5.3 HOPPER PARTS

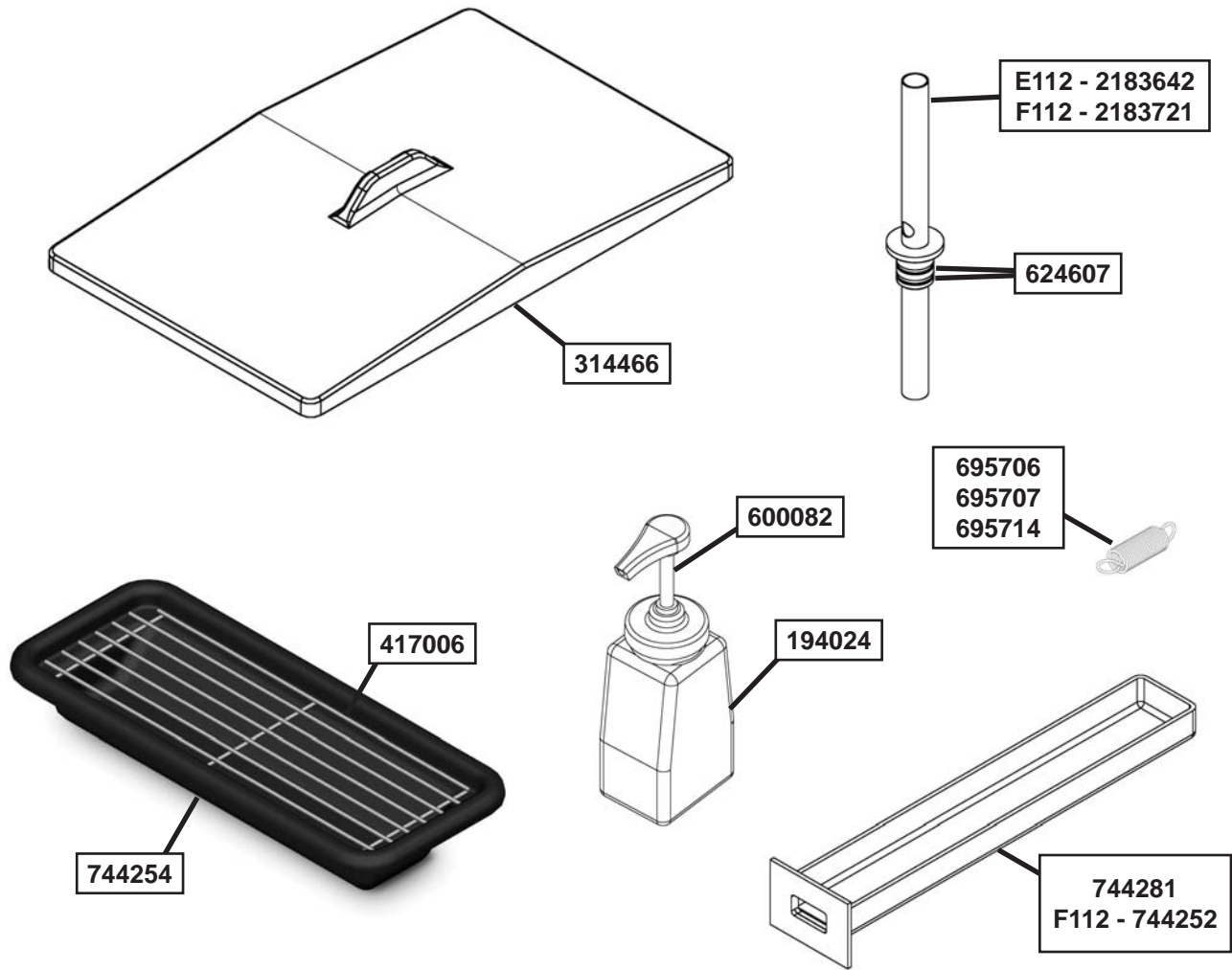

Part	Description	Quantity	
		E112	F112
194024	Bottle - Flavor (Plastic)	-	-
314466	Cover - Hopper (E112 - Non LJS) (F112 - Non Auto Fill)	1	1
417006	Grid - Drip Tray (Metal)	1	1
600082	Pump - Flavor (Plastic Bottle)	-	-
624607-5	O-Ring - Mix Inlet (5 Pack)	2	2
695706	Spring - Consistency Adjustment (Green)	1	
695707	Spring - Consistency Adjustment (Yellow)	1 (shake only)	1
695714	Spring - Consistency Adjustment (Red) (shake only)		1
744252	Tray - Drain (18 3/8" Long)		1
744254	Tray - Drip (E112 - Ser. #24587 Plus) (F112 - All)	1	1
744273	Tray - Drip (E112 - Ser. #0 - #24586)	1	
744281	Tray - Drain (Front) (12 3/4" Long)	1	1
744601	Tray - Drain (Rear)	1	
2177315	Cover - Hopper (E112 - LJS) (F112 - Auto Fill Kit)	-	-
2177316	Clip - Retaining (Mix Inlet) (Auto Fill Kit)		-
2177317	Mix Inlet Assembly (Auto Fill Kit)		-
2183642	Mix Inlet Assembly	1	
2183721	Mix Inlet Assembly		1
2187039	Rack - Flavor Bottle (F112)		-
2187041	Rack - Flavor Bottle (E112)	-	
2187918	Mix Inlet Assembly (LJS)		-
2187919	Clip - Retaining (Mix Inlet) (LJS)		-

## 5.4 AUTOFILL OPTIONS

The E112 and F112 machines can easily be configured to use an Autofill System. The Autofill System provides a constant supply of non-dairy mix to the machine.

### AUTOFILL KIT

An autofill kit is needed to use an Autofill System. The kit includes a solenoid, tubing, and a new hopper cover (the F112 also includes a transformer). See below for the Autofill Kit part numbers.

### AUTOFILL SYSTEMS

There are two Autofill Systems available: the Fill-O-Matic II and the Fill-O-Matic III. See below for details on the Autofill Systems.

#### Fill-O-Matic II

The Fill-O-Matic II is powered through an electrical outlet and pumps up to 60 gallons per hour.

#### Fill-O-Matic III

The Fill-O-Matic III is powered by gas and pumps up to 45 gallons per hour.



Fill-O-Matic II & Fill-O-Matic III

Fill-O-Matic II	
<b>Part Numbers</b>	Autofill System: 4177349 E112 Autofill Kit: 2183807 F112 Autofill Kit: 2187101
<b>Usage</b>	For use with non-potentially hazardous food substances; non-dairy
<b>Dimensions</b>	L 11-1/2" x W 11-1/2" x H 32-1/2"
<b>Electrical</b>	115VAC 60Hz 15A power cord provided
<b>Mix Storage</b>	15 gallon plastic tank
<b>Clean Process</b>	Removable strainer allows for easy cleaning
<b>Output</b>	Pumps up to 60 gallons per hour

Fill-O-Matic III	
<b>Part Numbers</b>	Autofill System: 4177370 E112 Autofill Kit: 2183807 F112 Autofill Kit: 2187101
<b>Usage</b>	For use with non-potentially hazardous food substances; non-dairy
<b>Dimensions</b>	L 11-1/2" x W 11-1/2" x H 27-1/2"
<b>Electrical</b>	No electrical connections required Powered by CO <sub>2</sub> , Nitrogen or compressed air
<b>Mix Storage</b>	15 gallon plastic tank
<b>Clean Process</b>	Clean-in-place by pumping solution through hoses
<b>Output</b>	Pumps up to 45 gallons per hour





**WARRANTY  
FROZEN UNCARBONATED BEVERAGE EQUIPMENT**

1. **Scope:**  
PW Stoelting, L.L.C. (“Stoelting”) warrants to the first user (the “Buyer”) that the evaporator assembly, compressors, drive motors, and speed reducers of Stoelting frozen uncarbonated beverage equipment will be free from defects in materials and workmanship under normal use and proper maintenance appearing within five (5) years, and that all other components of such equipment manufactured by Stoelting will be free from defects in material and workmanship under normal use and proper maintenance appearing within twelve (12) months after the date that such equipment is originally installed.
  
2. **Disclaimer of Other Warranties:**  

**THIS WARRANTY IS EXCLUSIVE; AND STOELTING, HEREBY DISCLAIMS ANY IMPLIED WARRANTY OF MERCHANTABILITY OR FITNESS FOR PARTICULAR PURPOSE.**
  
3. **Remedies:**  
Stoelting’s sole obligations, and Buyer’s sole remedies, for any breach of this warranty shall be the repair or (at Stoelting’s option) replacement of the affected component at Stoelting’s plant in Kiel, Wisconsin, or (again, at Stoelting’s option) refund of the purchase price of the affected equipment, and, during the first twelve (12) months of the warranty period, deinstallation/reinstallation of the affected component from/into the equipment. Those obligations/remedies are subject to the conditions that Buyer (a) signs and returns to Stoelting, upon installation, the Start-Up and Training Checklist for the affected equipment, (b) gives Stoelting prompt written notice of any claimed breach of warranty within the applicable warranty period, and (c) delivers the affected equipment to Stoelting or its designated service location, in its original packaging/crating, also within that period. Buyer shall bear the cost and risk of shipping to and from Stoelting’s plant or designated service location.
  
4. **Exclusions and Limitations:**  
This warranty does not extend to parts, sometimes called “wear parts”, which are generally expected to deteriorate and to require replacement as equipment is used, including as examples but not intended to be limited to o-rings, hoses, seals, and drive belts. All such parts are sold

**AS IS.**

Further, Stoelting shall not be responsible to provide any remedy under this warranty with respect to any component that fails by reason of negligence, abnormal use, misuse or abuse, use with parts or equipment not manufactured or supplied by Stoelting, or damage in transit.

**THE REMEDIES SET FORTH IN THIS WARRANTY SHALL BE THE SOLE LIABILITY STOELTING AND THE EXCLUSIVE REMEDY OF BUYER WITH RESPECT TO EQUIPMENT SUPPLIED BY STOELTING; AND IN NO EVENT SHALL STOELTING BE LIABLE FOR ANY INCIDENTAL OR CONSEQUENTIAL DAMAGES, WHETHER FOR BREACH OF WARRANTY OR OTHER CONTRACT BREACH, NEGLIGENCE OR OTHER TORT, OR ON ANY STRICT LIABILITY THEORY.**