



**Model E112-LJ / F112-LJ**  
**OPERATORS MANUAL**

Manual No. 513643

Feb. 2010



This manual provides basic information about the machine. Instructions and suggestions are given covering its operation and care.

The illustrations and specifications are not binding in detail. We reserve the right to make changes to the machine without notice, and without incurring any obligation to modify or provide new parts for machines built prior to date of change.

**DO NOT ATTEMPT** to operate the machine until instructions and safety precautions in this manual are read completely and are thoroughly understood. If problems develop or questions arise in connection with installation, operation, or servicing of the machine, contact Stoelting.



[stoeltingfoodservice.com](http://stoeltingfoodservice.com)

Stoelting Foodservice Equipment  
502 Highway 67  
Kiel, WI 53042-1600  
U.S.A.

Main Tel: 800.558.5807  
Fax: 920.894.7029

Customer Service: 888.429.5920  
Fax: 800.545.0662  
Email: [foodservice@stoelting.com](mailto:foodservice@stoelting.com)

© 2014 PW Stoelting, LLC

---

## ***A Few Words About Safety***

### **Safety Information**

**Read and understand the entire manual before operating or maintaining Stoelting equipment.**

This manual provides the operator with information for the safe operation and maintenance of Stoelting equipment. As with any machine, there are hazards associated with their operation. For this reason safety is emphasized throughout the manual. To highlight specific safety information, the following safety definitions are provided to assist the reader.

The purpose of safety symbols is to attract your attention to possible dangers. The safety symbols, and their explanations, deserve your careful attention and understanding. The safety warnings do not by themselves eliminate any danger. The instructions or warnings they give are not substitutes for proper accident prevention measures.

If you need to replace a part, use genuine Stoelting parts with the correct part number or an equivalent part. We strongly recommend that you do not use replacement parts of inferior quality.



### **Safety Alert Symbol:**

**This symbol** Indicates danger, warning or caution. Attention is required in order to avoid serious personal injury. The message that follows the symbol contains important information about safety.

### **Signal Word:**

Signal words are distinctive words used throughout this manual that alert the reader to the existence and relative degree of a hazard.



The signal word "WARNING" indicates a potentially hazardous situation, which, if not avoided, may result in death or serious injury and equipment/property damage.



The signal word "CAUTION" indicates a potentially hazardous situation, which, if not avoided, may result in minor or moderate injury and equipment/property damage.

### **CAUTION**

The signal word "CAUTION" not preceded by the safety alert symbol indicates a potentially hazardous situation, which, if not avoided, may result in equipment/property damage.

### **NOTE (or NOTICE)**

The signal word "NOTICE" indicates information or procedures that relate directly or indirectly to the safety of personnel or equipment/property.

# TABLE OF CONTENTS

<b>Section</b>	<b>Description</b>	<b>Page</b>
<b>1</b>	<b>Description and Specifications</b>	
1.1	Description .....	1
1.2	Specifications .....	2
<b>2</b>	<b>Installation Instructions</b>	
2.1	Safety Precautions .....	5
2.2	Shipment and Transit .....	5
2.3	Machine Installation .....	5
2.4	Auto Fill Pump Installation .....	6
<b>3</b>	<b>Initial Set-Up and Operation</b>	
3.1	Operator's Safety Precautions .....	7
3.2	Operating Controls and Indicators .....	7
3.3	Removing Mix From Machine .....	8
3.4	Disassembly of Machine Parts .....	8
3.5	Cleaning and Sanitizing the Machine Parts .....	9
3.6	Assembly of Machine .....	10
3.7	Sanitizing .....	11
3.8	Freeze Down and Operation .....	11
3.9	Mix Information .....	12
3.10	Routine Cleaning .....	12
3.11	Preventative Maintenance .....	12
3.12	Extended Storage .....	14
<b>4</b>	<b>Troubleshooting</b>	
4.1	Light Indicators .....	15
4.2	Troubleshooting .....	15
4.3	Troubleshooting - Auto Fill System .....	16
<b>5</b>	<b>Replacement Parts</b>	
5.1	Decals and Lubrication .....	17
5.2	Auger Shaft and Faceplate Parts .....	18
5.3	Hopper Parts .....	20
5.4	Auto Fill Parts .....	21



# SECTION 1 DESCRIPTION AND SPECIFICATIONS

## 1.1 DESCRIPTION

The Stoelting E112-LJ /F112-LJ counter machines are gravity fed. The machines are equipped with fully automatic controls to provide a uniform product. This manual is designed to help qualified service personnel and operators with the installation, operation and maintenance of the Stoelting E112-LJ/F112-LJ gravity machines.



Figure 1-1 Model F112-LJ



Figure 1-1 Model E112-LJ





1.2 SPECIFICATIONS - CONTINUED

	<b>Model E112</b>		<b>Model F112</b>	
<b>Dimensions</b>	<b>Machine</b>	<b>with crate</b>	<b>Machine</b>	<b>with crate</b>
width	15-1/4" (38,7 cm)	17-1/2" (44,5 cm)	17-1/4" (43,8 cm)	29" (73,7 cm)
height	30-1/2" (77,5 cm)	35" (88,9 cm)	33" (83,8 cm)	44" (111,8 cm)
depth	32" (81,3 cm)	36-1/2" (92,7 cm)	30-1/4" (76,8 cm)	39" (99,1 cm)
<b>Weight</b>	205 lbs (92,9 kg)	215 lbs (97,5 kg)	288 lbs (130,6 kg)	315 lbs (142,8 kg)
<b>Electrical</b>	<b>1 Phase, 115 VAC, 60Hz</b>		<b>1 Phase, 208-240 VAC, 60Hz</b>	
running amps	approximately 16A		approximately 10A	
connection type	NEMA5-20P power cord provided		NEMA6-15P power cord provided	
International Option	1 Phase, 220-240 VAC, 50Hz		1 Phase, 220-240 VAC, 50Hz	
<b>Compressor</b>	6,000 Btu/hr		8,600 Btu/hr	
<b>Drive Motor</b>	1/3 hp		3/4 hp	
<b>Air Flow</b>	Air cooled units require 3" (7,6 cm) air space on both sides or 4" (10,2 cm) air space in back for side-by-side installation		Air cooled units require 6" (15,24 cm) air space on both sides	
<b>Plumbing Fittings</b>	N/A		Water cooled units require 3/8" N.P.T. water and drain fittings.	
<b>Hopper Volume</b>	3.625 gallon (13,73 liters)		5.375 gallon (20,35 liters)	
<b>Freezing Cylinder Volume</b>	1.25 gallon (5 quart), 4,73 liters		2.125 gallon (8.5 quart), 8,04 liters	
<b>Production Capacity</b>	18 GPH (68,15 liters)		24 GPH (90,87 liters)	



## SECTION 2 INSTALLATION INSTRUCTIONS

### 2.1 SAFETY PRECAUTIONS

Do not attempt to operate the machine until the safety precautions and operating instructions in this manual are read completely and are thoroughly understood.

Take notice of all warning labels on the machine. The labels have been put there to help maintain a safe working environment. The labels have been designed to withstand washing and cleaning. All labels must remain legible for the life of the machine. Labels should be checked periodically to be sure they can be recognized as warning labels.

If danger, warning or caution labels are needed, indicate the part number, type of label, location of label, and quantity required along with your address and mail to:

**STOELTING**  
**ATTENTION: Customer Service**  
**502 Hwy. 67**  
**Kiel, Wisconsin 53042**

### 2.2 SHIPMENT AND TRANSIT

The machine has been assembled, operated and inspected at the factory. Upon arrival at the final destination, the entire machine must be checked for any damage which may have occurred during transit.

With the method of packaging used, the machine should arrive in excellent condition. **THE CARRIER IS RESPONSIBLE FOR ALL DAMAGE IN TRANSIT, WHETHER VISIBLE OR CONCEALED.** Do not pay the freight bill until the machine has been checked for damage. Have the carrier note any visible damage on the freight bill. If concealed damage and/or shortage is found later, advise the carrier within 10 days and request inspection. The customer must place claim for damages and/or shortages in shipment with the carrier. Stoelting cannot make any claims against the carrier.

### 2.3 MACHINE INSTALLATION

Installation of the machine involves moving the machine close to its permanent location, removing all crating, setting in place, assembling parts, and cleaning.

- A. Uncrate the machine.
- B. Determine the location of the machine. The location must be able to hold 350 lbs.
- C. Accurate leveling is necessary for correct drainage of machine barrel and to insure correct overrun. Place a bubble level on top of the machine at each corner to check for level condition. If adjustment is necessary, level the machine by turning the bottom part of each leg in or out.
- D. The F112-LJ has a base gasket that must be installed. Separate the gasket and install it with the seam to the back. Make sure the angled side of the gasket is facing up.



**Figure 2-2 Space and Ventilation Requirements**

- E. Correct ventilation is required. The E112-LJ requires 3" clearance on both sides. If the machine is placed side-by-side next to other equipment, there needs to be at least 4" clearance at the back of the machine. The air-cooled F112-LJ requires 6" clearance on both sides for proper air flow.

#### CAUTION

Failure to provide adequate ventilation will void warranty.

- F. Connect the drip tray bracket by loosening the two screws at the front of the machine. Install the bracket so that it rests on the nylon washer between the two metal washers. Tighten the screws.



**Figure 2-3 Drip Tray Bracket**

- G. Place the CLEAN-ON-OFF switch in the OFF position.

**WARNING**

Do not alter or deform electrical plug in any way. Altering the plug to fit into an outlet of different configuration may cause fire, risk of electrical shock, product damage and will void warranty.

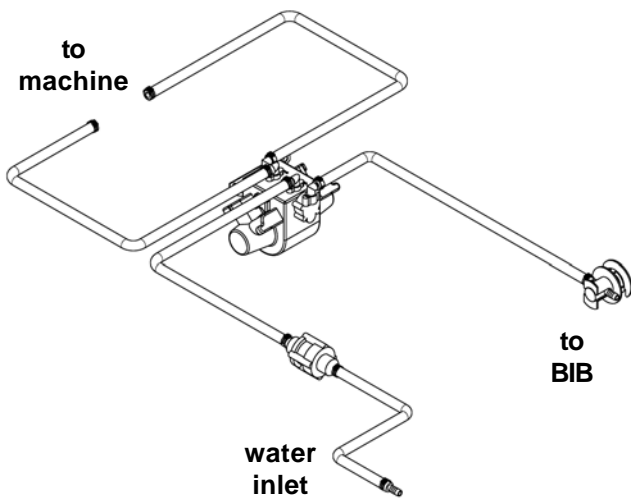
- H. Connect the power cord to the proper power supply. The plug on the E112 is designed for 115VAC / 20 amp duty and the plug on the F112 is designed for 208-240VAC / 15 amp duty. Check the nameplate on your machine for proper supply. The unit must be connected to a properly grounded receptacle. The electrical cord furnished as part of the machine has a three prong grounding type plug. The use of an extension cord is not recommended, if necessary use one with a size 12 gauge or heavier with ground wire. Do not use an adapter to get around grounding requirement.

**2.4 AUTO FILL PUMP INSTALLATION**

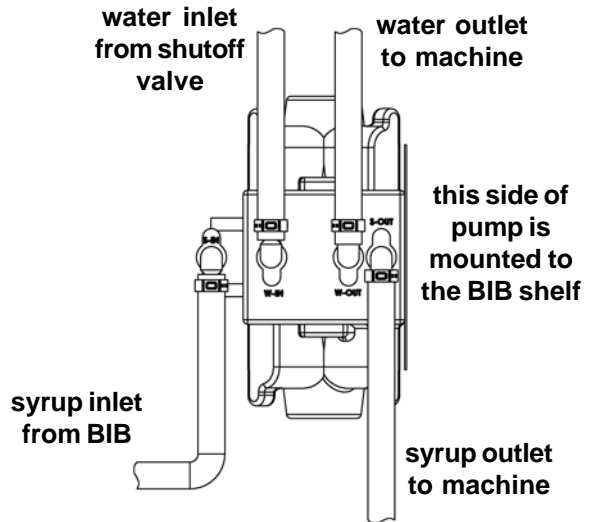
The auto fill pump is powered by water and has a fixed orifice that delivers water and syrup to the machine at an exact ratio. The auto fill kit is designed for use with Bag In Box (BIB) concentrated syrup.

Follow these instructions to properly install the brix pump

- A. Route the clear tubing with the BIB connector to the BIB. If there is excess tubing, trim it and reconnect it to the BIB connector.
- B. Route the water line tubing to the shutoff valve of the water supply. Trim excess tubing and connect it to the shutoff valve.
- C. Route the water line and syrup line tubing (3/8" braided tubing) from the pump to the machine.

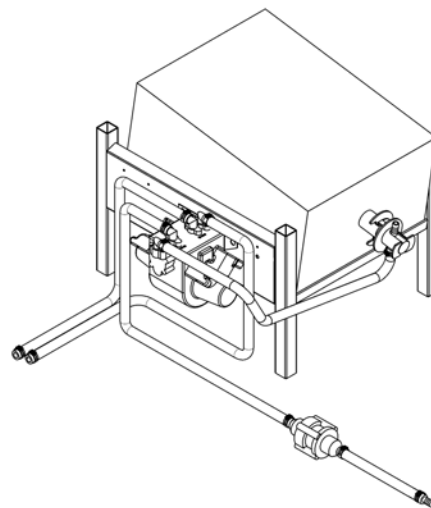


**Figure 2-4 Auto Fill Pump Tubing Layout**



**Figure 2-5 Top View of Pump**

- D. Route the water line tubing to the tube exiting the rear panel. Trim excess tubing and connect.
- E. Route the syrup line to the tubing connected to the adapter on the hopper cover. Trim excess tubing and connect.
- F. Check that the clear tubing coming out of the rear panel is connected to the plug in the hopper cover. If not, connect it using a clamp in the kit.
- G. Check that all tubing connections are properly clamped, fittings are tightened and the tubing is not kinked.



**Figure 2-6 Auto Fill Pump Kit**

## SECTION 3 INITIAL SET-UP AND OPERATION

### 3.1 OPERATOR'S SAFETY PRECAUTIONS

SAFE OPERATION IS NO ACCIDENT; observe these rules:

- A. Know the machine. Read and understand the Operating Instructions.
- B. Notice all warning labels on the machine.
- C. Wear proper clothing. Avoid loose fitting garments, and remove watches, rings or jewelry that could cause a serious accident.
- D. Maintain a clean work area. Avoid accidents by cleaning up the area and keeping it clean.
- E. Stay alert at all times. Know which switch, push button or control you are about to use and what effect it is going to have.
- F. Disconnect electrical cord for maintenance. Never attempt to repair or perform maintenance on the machine until the main electrical power has been disconnected.
- G. Do not operate under unsafe operating conditions. Never operate the machine if unusual or excessive noise or vibration occurs.

### 3.2 OPERATING CONTROLS AND INDICATORS

Before operating the machine, it is required that the operator know the function of each operating control. Refer

#### **WARNING**

High voltage will shock, burn or cause death. The OFF-ON switch must be placed in the OFF position prior to disassembling for cleaning or servicing. Do not operate machine with cabinet panels removed.

to Figure 3-1 for the location of the operating controls on the machine.

#### A. **Spigot Switch**

The spigot switch will automatically start the auger drive and refrigeration systems when the spigot is opened to dispense product. When the spigot is closed, the drive motor and compressor will remain on until the product in the freezing cylinder reaches the proper consistency..



**Figure 3-1 Controls**

**B. CLEAN-OFF-ON Switch**

The CLEAN-OFF-ON switch is used to supply power to the control circuit. When the switch is in the OFF (middle) position, power will not be supplied to the control board or refrigeration system. When the switch is in the ON position, the machine will operate in the freezing mode. When the switch is in the CLEAN position, all refrigeration will stop and the auger will start rotating.

**C. ADD MIX Light**

The ADD MIX light will flash to alert the operator to a low mix condition. It does so by monitoring the mix level in the hopper. If the ADD MIX light is flashing, check the auto fill system to determine the issue. Refer to the troubleshooting section for details

**D. Diagnostic Light**

The Diagnostic Light will remain lit for defrost mode. It will flash if an error occurs. The light will flash once if there is a compressor error. There will be two quick flashes if there is an auger error. And there will be three quick flashes if the machine is left in clean mode for more than 20 minutes. Refer to the troubleshooting section for details.

**E. Consistency Adjustment Screw**

The Consistency Adjustment Screw increases or decreases product consistency. A tension spring is connected to the screw and changes the amount of torque needed to complete a refrigeration cycle. Turn the knob clockwise to increase consistency or counterclockwise to decrease consistency.

**F. Front Door Safety Switch**

The front door safety switch prevents the auger from turning when the front door is removed. The switch is open when the door is not in place and closed when the door is properly installed.

**G. Hopper Probes**

The mix level in the hopper is controlled by two probes. When mix in the hopper gets below the long probe, the solenoid opens and the hopper fills. When the mix level reaches the short probe, the solenoid closes.

**3.3 REMOVING MIX FROM MACHINE**

To remove the mix from the machine, refer to the following steps:

- A. Wash, rinse, dry and sanitize hands before starting.
- B. Turn the water line lever to the Off position.
- C. Place the Clean/Off/On switch to Clean and drain the mix from the freezer into a utility bucket and turn off the machine. Discard mix into the second compartment of a 3-compartment sink.
- D. Fill the hopper with 2 gallons of clean, cold water using the clean white utility bucket.
- E. Place the Clean/Off/On switch to Clean. Run the machine in Clean mode for approximately 5 minutes. Continue to the next step while the machine is cleaning.
- F. Prepare Stera-Sheen Green Label Sanitizer according to manufacturer's instructions to provide a 100ppm strength solution. In the blue cleaner/sanitizer bucket, mix 1 packet of sanitizer and 2 gallons of cold water. Check the chlorine content with a test strip to ensure 100ppm strength.
- G. After 5 minutes, drain the water from the machine into the red utility bucket and discard the water.

**NOTE**


*If the water does not drain clear, repeat the steps.*

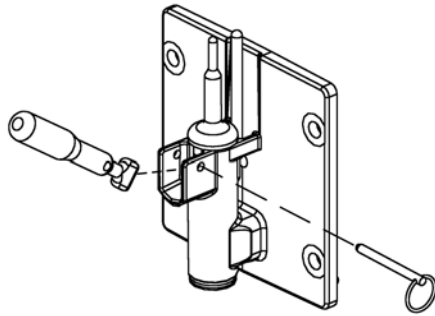
- H. Place the Clean/Off/On switch Off.
- I. Fill the hopper with the 2 gallons of sanitizer solution from the blue bucket.
- J. Place the Clean/Off/On switch to Clean. Run the machine in Clean mode for approximately 5 minutes.
- K. After 5 minutes, drain the sanitizer solution from the machine into the red utility bucket and discard the solution.

**3.4 DISASSEMBLY OF MACHINE PARTS**

Inspect for worn or broken parts each time the machine is disassembled. Replace any worn or broken parts to ensure safety to both the operator and the customer and to maintain good machine performance and a quality product. Frequency of cleaning must comply with the local health regulations.

To disassemble the machine, refer to the following steps:

 <b>CAUTION</b>
<p><b>Hazardous Moving Parts.</b> Revolving auger shaft can grab and cause injury. Place the switch in the OFF (middle) position before disassembling for cleaning or servicing.</p>



**Figure 3-2 Remove Spigot Pin**

- A. Pull out the spigot pin by its ring. Remove the spigot handle.

**NOTE**

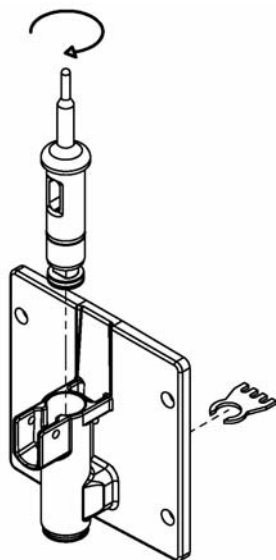
*Place all parts into the lemonade parts basket immediately after removing from the machine. Place small parts onto the small parts rod in the basket.*

- B. Remove front door by turning the circular knobs and then pulling door off the studs.

**NOTE**

*When removing front door, entire door and stator assembly will come out as well.*

- C. Remove the torque rod from the stator assembly.
- D. Remove the quad ring from the groove in front door.
- E. Remove the stator bar. Remove the small white bushing.



**Figure 3-3 Spigot and Ice Breaker Bar Removal**



**Figure 3-4 Removing O-Ring**

- F. Remove the o-rings at the front and back of the stator bar by first wiping off the lubricant using a clean paper towel. Then squeeze the o-ring upward with a dry cloth. When a loop is formed, roll the o-ring out of the groove.
- G. Remove the auger support bushing.
- H. Turn the spigot body until the ice breaker bar can be removed. Remove breaker bar.
- I. Remove the spigot body from the front door.
- J. Remove the o-rings (2) from the spigot.
- K. Remove the auger assembly from the freezing cylinder and remove the auger blade. Remove the rear seal and o-ring from the auger.
- L. Remove the drain tray, drip tray and drip tray grid.
- M. Remove the hopper cover and disconnect the auto fill adapter from the cover by pulling out the retaining clip.

**3.5 CLEANING AND SANITIZING THE MACHINE PARTS**

Place all loose parts in a pan or container and take to the wash sink for cleaning. Local and state health codes dictate the procedure required. Some health codes require a four-sink process (pre-wash, wash, rinse, sanitize, and air-dry), while other codes require a three-sink process (without the pre-wash step). The following procedures are a general guideline only. Consult your local and state health codes for procedures required in your location.

- A. Set up a 3-compartment sink with wash, rinse and sanitize compartments. Use only Stera Sheen Green Label or Kay-5 Green. Prepare sanitizer according to manufacturer's instructions to provide a 100ppm strength solution. Set aside a small amount of sanitizer
- B. Clean all parts using brushes provided.
- C. After cleaning, remove the parts and let air dry.





**Figure 3-5 Cleaning Freezing Cylinder**

- D. Sanitize the hopper and freezing cylinder with sanitizer. Be sure to clean the rear seal surfaces inside the freezing cylinder.
- E. Wipe down the outside of the machine and table with a yellow sanitized towel.

### 3.6 ASSEMBLY OF MACHINE

**CAUTION**

Do not allow sanitizer to remain in contact with stainless steel parts for prolonged periods. Prolonged contact of sanitizer with machine may cause corrosion of stainless steel parts.

To assemble the machine parts, refer to the following steps:

**NOTE**

*Petrol Gel sanitary lubricant or equivalent must be used when lubrication of parts is specified.*

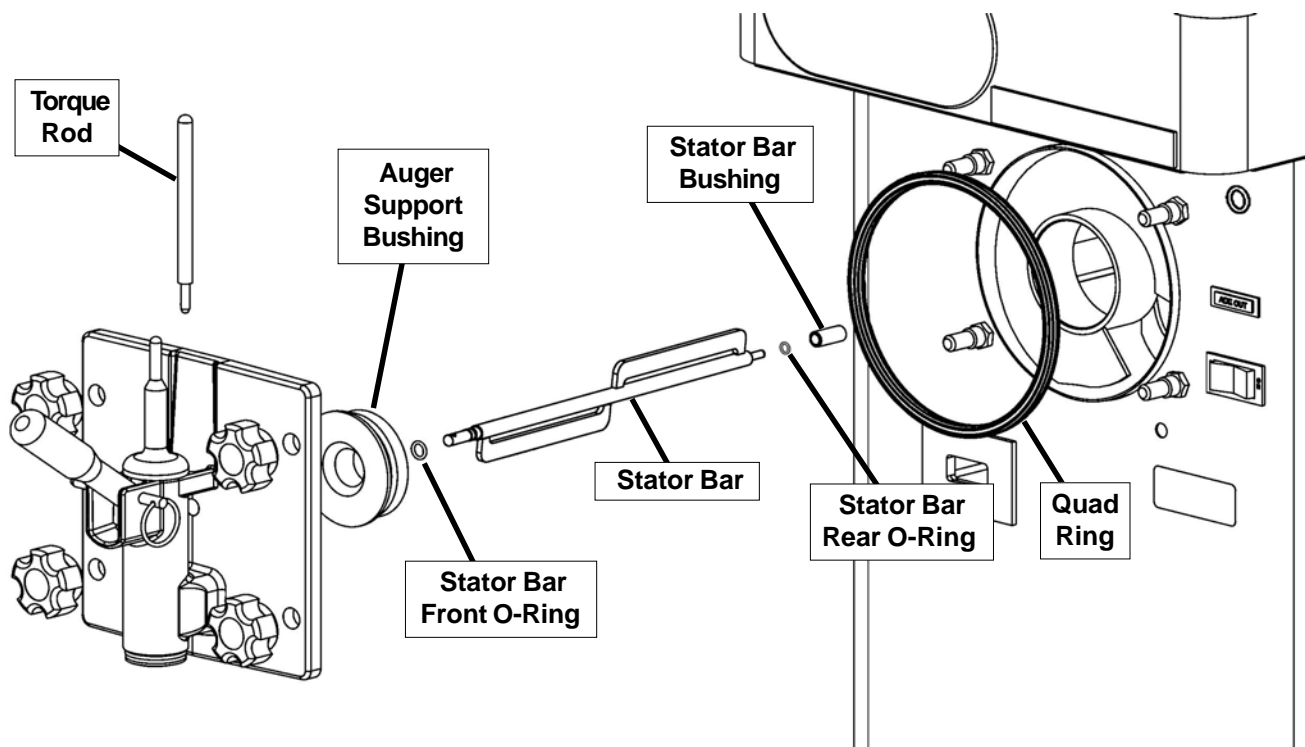
**NOTE**

*The United States Department of Agriculture and the Food and Drug Administration require that lubricants used on food processing equipment be certified for this use. Use lubricants only in accordance with the manufacturer's instructions.*

- A. Wash, rinse, dry and sanitize hands before starting.
- B. Place the rear seal o-ring onto the auger and apply a thin film of Petrol-Gel to the o-ring.
- C. Assemble the rear seal onto the auger with the large end of the seal to the rear. Lubricate the hex end of the auger with a small amount of spline lubricant.
- D. Install the plastic auger blade onto the auger. Push the auger into the freezing cylinder and rotate it slowly until the auger engages the drive shaft.
- E. Assemble the o-rings onto the spigot body and apply a thin film of Petrol-Gel onto the o-rings.
- F. Insert the spigot body into the front door.

**NOTE**

*When inserting the spigot body, press the o-rings against the spigot to prevent damage.*



**figure 3-6 Door and Stator Assembly**



- G. Turn the spigot body until the ice breaker bar can be inserted. Insert the ice breaker bar and rotate spigot body 90°.
- H. Apply Petrol-Gel to the inside and outside of the front auger support bushing. Install the bushing onto the front door so the beveled edge of the bushing is against the door.
- I. Install the large quad ring into the groove in the front door.
- J. Install the o-rings at the front and back of the stator bar. Apply a thin film of Petrol-Gel onto the o-rings. Install the small white bushing to the stator bar.
- K. Insert the stator bar into the front door and insert the torque rod through the hole in the stator bar.
- L. Install the front door onto the freezer. Install the knobs onto the studs.

**NOTE**

*When installing the front door, the torque rod must be placed in the center notch of the torque actuator arm.*

- M. Insert the spigot handle so the hole lines up and insert the spigot pin.
- N. Install the drain tray, drip tray and drip tray grid.

**3.7 SANITIZING**

Sanitizing must be done after the machine is cleaned and just before the hopper is filled with mix. Sanitizing the night before is not effective. However, you should always clean the machine and parts after each use.

The United States Department of Agriculture and the Food and Drug Administration require that all cleaning and sanitizing solutions used with food processing equipment be certified for this use.

When sanitizing the machine, refer to local sanitary regulations for applicable codes and recommended sanitizing products and procedures. The frequency of sanitizing must comply with local health regulations.

Mix sanitizer according to manufacturer’s instructions to provide a 100 parts per million (ppm) strength solution and check the solution with chlorine test strips. Mix sanitizer in quantities of no less than 2 gallons (7.5 liters) of 90° to 110°F (32° to 43°C) water. Allow sanitizer to contact the surfaces to be sanitized for 5 minutes. Any sanitizer must be used only in accordance with the manufacturer’s instructions.

In general, sanitizing may be conducted as follows:

- A. Prepare Stera-Sheen Green Label Sanitizer according to manufacturer’s instructions to provide a 100ppm strength solution. In the blue cleaner/sanitizer bucket, mix 1 packet of sanitizer and 2 gallons of cold water. Check the chlorine content with a test strip to ensure 100ppm strength.
- B. Pour the sanitizing solution into the hopper.
- C. Place the Clean/Off/On switch to Clean.
- D. Use a sanitized barrel brush to sanitize the hopper sides and hopper cover with the sanitizer solution in the hopper.
- E. After 5 minutes, drain the sanitizer solution from the machine into the red utility bucket and discard the solution. Leave a small amount of sanitizer solution in the freezing cylinder.
- F. Place the Clean/Off/On switch Off.
- G. Collect the remaining sanitizer in a clean cup and check the chlorine content with a test strip. If the chlorine content is less than 100ppm, repeat the sanitizing procedure. If the test strip does not read 100ppm after the second test, repeat the disassembly, cleaning and sanitizing procedures.
- H. Connect the auto fill adapter to the hopper cover with the retaining clip and place the hopper cover onto the hopper.
- I. Turn the water line lever to the On position.
- J. Turn the Clean/Off/On switch On. Open the spigot to drain out any remaining sanitizer into the red utility bucket. Close the spigot when mix begins coming out.

**3.8 FREEZE DOWN AND OPERATION**

This section covers the recommended operating procedures for the safe operation of the machine.

- A. After the freezing cylinder is filled, product will be ready to serve in 8 to 12 minutes.
- B. To dispense, pull the spigot handle down to open the spigot.

<b>CAUTION</b>
Do not allow sanitizer to remain in contact with stainless steel parts for prolonged periods. Prolonged contact of sanitizer with machine may cause corrosion of stainless steel parts.

- C. The machine is designed to dispense the product at a reasonable draw rate. If the machine is overdrawn, the result is a wet product or a product that will not dispense at all. If this should occur, allow the machine to run for approximately 30 seconds before dispensing additional product.
- D. Do not operate the machine when the ADD MIX light is on. Immediately check if the auto fill system is operating properly.

**NOTE**

*After 3 hours if the spigot is not opened, the machine will go into defrost mode. During this time, the diagnostic light will be lit and the auger will run for 90 seconds every 7 minutes. Defrost mode maintains consistency in the product and prevents large ice crystals from forming. To end defrost mode, turn the Clean/Off/On switch Off then back On. Defrost mode will also end if the spigot is opened.*

**3.9 MIX INFORMATION**

Mix can vary considerably from one manufacturer to another. Differences in the quantity and quality of ingredients have a direct bearing on the finished frozen product. A change in machine performance that cannot be explained by a technical problem may be related to the mix.

Proper product serving temperature varies from one manufacturer’s mix to another. Stackable slush mixes provide satisfactory product from 24° to 28°F (-4° to -2°C).

When checking the temperature, stir the thermometer in the frozen product to obtain an accurate reading.

**3.10 ROUTINE CLEANING**

To remove spilled or dried mix from the machine exterior, wash in the direction of the finish with warm soapy water and wipe dry. Do not use highly abrasive materials as they will mar the finish.

**3.11 PREVENTIVE MAINTENANCE**

Stoelting recommends that a maintenance schedule be followed to keep the machine clean and operating properly.

**B. DAILY**

- 1. The exterior should be kept clean at all times to preserve the luster of the stainless steel. A mild alkaline cleaner is recommended. Use a soft cloth or sponge to apply the cleaner.

**C. WEEKLY**

- 1. Check o-rings and rear seal for excessive wear and replace if necessary.
- 2. Remove the drip tray by gently lifting up to disengage from the support and pulling out. Clean behind the drip tray and front of the machine with a soap solution.

**D. QUARTERLY**

**Air Cooled**

The air-cooled condenser is a copper tube and aluminum fin type. Condensing is totally dependent upon airflow. A plugged condenser filter, condenser, or restrictions in the louvered panel will restrict airflow. This will lower the capacity of the system and damage the compressor.

The condenser must be kept clean of dirt and grease. The F112 must have a minimum of 6” (15.2 cm) of ventilation on the right and left sides of the unit for free flow of air. The E112 must have 3” (7.6 cm) of ventilation. Make sure the machine is not pulling over 100° F (37° C) air from other equipment in the area.

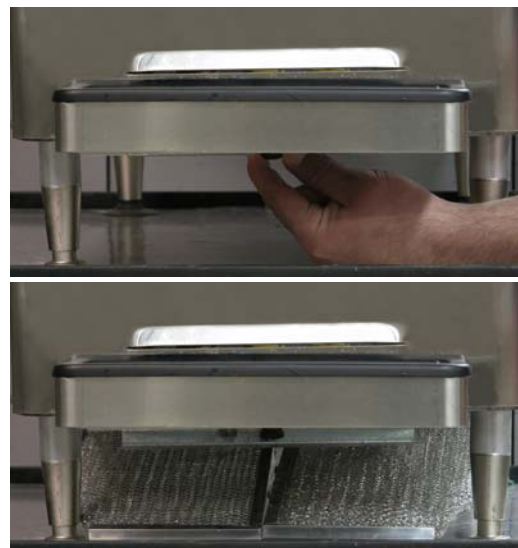
The condenser and condenser filter require periodic cleaning. To clean, refer to the following procedures.

**E112 Air Cooled Condenser Cleaning**

- A. Unscrew the knob located on the underside of the machine towards the front (Fig. 3-7).
- B. Remove the filter bracket and remove the filter.
- C. Visually inspect the condenser filter for dirt.
- D. If the filter is dirty, vacuum or brush clean, rinse with clean water and allow to dry before replacing on the machine.

**NOTE**

*If the condenser is not kept clean, refrigeration efficiency will be lost.*



**Figure 3-7 E112 Condenser Filter Removal**



**Figure 3-8 F112 Condenser Filter Removal**

### F112 Air Cooled Condenser Cleaning

- A. Remove the Phillips head screws from the bottom of the left side panel, and then slide the panel down and out.
- B. To remove the condenser filter, grasp the top and pull off. Visually inspect for dirt. If the filter is dirty, shake or brush excess dirt off the filter and wash in warm, soapy water. Once the filter is clean rinse thoroughly in warm, clear water and shake dry, taking care not to damage the filter in any way (Fig. 3-8).
- C. Visually inspect the condenser for dirt by shining a light through the coil from the back (inside) of the condenser.
- D. If the condenser is dirty, place a wet towel over the front (outside) of the condenser.
- E. Using a vacuum, carefully clean the condenser coil from the inside and outside of the machine. A stiff bristled brush may help in releasing debris from between the condenser coils.

### Water Cooled (F112 only)

The water-cooled condenser is a tube and shell type. The condenser needs a cool, clean supply of water to properly cool the machine, inlet and discharge lines must be 3/8" I.D. minimum. Make sure the machine is receiving an unrestricted supply of cold, clean water.

### E. SEMI-ANNUALLY

1. Disconnect the machine from the power source.
2. Check drive belt for proper tension. Push belt in with one finger, belt should deflect about 3/8".
3. Lubricate condenser fan motor with S.A.E. 20 weight oil. Three to six drops are required.

4. Sanitize the autofill system following the steps below:

### AUTO FILL SANITIZING

- A. If necessary, disassemble, clean and sanitize the machine.

### NOTE

*If the machine does not require cleaning and sanitizing, turn it off and dispense enough product so that the mix level in the hopper is below the long probe. If the mix level is above the long probe, the solenoid will not activate and the pump will not operate.*

- B. Prepare Stera-Sheen Green Label Sanitizer according to manufacturer's instructions to provide a 100ppm strength solution. In the blue cleaner/sanitizer bucket, mix 1 packet of sanitizer and 2 gallons of cold water. Check the chlorine content with a test strip to ensure 100ppm strength.
- C. Cut an adapter from an empty bag of syrup. Connect the adapter to the BIB connector of the syrup line. Put the BIB connector into the bucket of sanitizer.

### NOTE

*If you do not have an empty bag of syrup, remove the plug from the top of the BIB connector. Do not lose the plug; it is needed for proper operation of the BIB.*

- D. Hold the hopper cover over a bucket and set the machine to clean. The solenoid will activate and the brix pump will pump sanitizer into the bucket.

### NOTE

*The solenoid will only activate when there is not any liquid touching the longer mix probe in the hopper.*

- E. After all the sanitizer has run through the pump, turn the machine off.
- F. Disconnect the bag adapter from the BIB connector (or reinsert the plug into the connector). Connect the BIB connector to the syrup BIB.
- G. Set the machine to clean and hold the hopper cover over a bucket. This will flush the sanitizer out of the pump and tubing. When pure syrup comes out of the tubing, turn the machine off.
- H. The machine is now ready to operate. Place the hopper cover on the hopper and turn the machine on.

### 3.12 EXTENDED STORAGE

Refer to the following steps for storage of the machine over any long period of shutdown time:

- A. Follow the cleaning and sanitizing procedures for the machine and follow the semi-annual instructions to sanitize the auto fill system.
- B. Place the CLEAN-OFF-ON switch in the OFF (middle) position.
- C. Disconnect (unplug) from the electrical supply source.
- D. Clean thoroughly with a warm water detergent all parts that come in contact with the mix. Rinse in clean water and dry parts. Do not sanitize.

#### **NOTE**

*Do not let the cleaning solution stand in the hopper or in the freezing cylinder during the shutdown period.*

- E. Remove, disassemble and clean the front door, mix inlet regulator and auger parts.
- F. In a water cooled machine, disconnect water lines and drain water. With a flathead screwdriver, hold the water valve open and use compressed air to clear the lines of any remaining water.

## SECTION 4 TROUBLESHOOTING

### 4.1 LIGHT INDICATORS

The machine has two lights that will alert the user if a problem occurs: an ADD MIX light and a Diagnostic Light.

The ADD MIX light will flash to alert the operator to a low mix condition. It does so by monitoring the mix level in the hopper. When the ADD MIX light is flashing, refill hopper immediately.

The Diagnostic Light will flash if an error occurs. Refer to the chart below for details.

Indication	On	One Blink	Two Blinks	Three Blinks
<b>Conditions</b>	Defrost Mode	Torque is not met after 20 minutes	Drive current is not sensed	Machine left in clean mode for over 20 minutes
<b>Self Correction</b>	N/A	N/A	The machine attempts to sense drive current with a 3 second pre-stir. If current is sensed, the machine will return to normal operation. If current is not sensed, the machine will wait 7 minutes and try to sense current with another 3 second pre-stir. After the third attempt, the compressor will run on timers.	N/A
<b>Operation</b>	Every 7 minutes the auger will run for 90 seconds.	Timers or until torque switch remains closed for 3 seconds.	Timers	Off
<b>Corrective Action</b>	End Defrost Mode by turning Clean/Off/On switch OFF then turning it back ON. Opening the spigot will also end Defrost Mode.	Contact Service Technician	Contact Service Technician	Turn Clean/Off/On switch OFF then turn it back ON.

### 4.2 TROUBLESHOOTING

PROBLEM	POSSIBLE CAUSE	REMEDY
<b>Machine does not run.</b>	<ol style="list-style-type: none"> <li>1 Power to machine is off.</li> <li>2 Blown fuse or tripped circuit.</li> <li>3 Freeze-up (auger will not turn).</li> <li>4 Front door not in place.</li> </ol>	<ol style="list-style-type: none"> <li>1 Supply power to machine.</li> <li>2 Replace or reset.</li> <li>3 Turn Clean/Off/On switch Off for 15 minutes, then restart.</li> <li>4 Assemble front door in place.</li> </ol>
<b>Machine will not shut off.</b>	<ol style="list-style-type: none"> <li>1 Drive belt failure.</li> <li>2 Consistency temperature setting is too firm.</li> <li>3 Refrigeration problem.</li> </ol>	<ol style="list-style-type: none"> <li>1 Replace drive belt.</li> <li>2 Turn Consistency Adjustment knob counter-clockwise.</li> <li>3 Check system. (Call distributor for service)</li> </ol>
<b>Product is too firm.</b>	<ol style="list-style-type: none"> <li>1 Consistency temperature setting is too firm.</li> </ol>	<ol style="list-style-type: none"> <li>1 Turn Consistency Adjustment knob counter-clockwise.</li> </ol>

#### 4.2 TROUBLESHOOTING - CONTINUED

PROBLEM	POSSIBLE CAUSE	REMEDY
<b>Product is too thin.</b>	<ol style="list-style-type: none"> <li>1 No vent space for free flow of cooling air.</li> <li>2 Condenser is dirty.</li> <li>3 Consistency setting too soft.</li> <li>4 Auger is assembled incorrectly.</li> <li>5 Auto Fill Pump not operating.</li> <li>6 Refrigeration problem.</li> </ol>	<ol style="list-style-type: none"> <li>1 A minimum of 6" of air space on both sides (the E112 requires 3"). (See Section 2)</li> <li>2 Clean. (See Section 3)</li> <li>3 Turn Consistency Adjustment knob clockwise.</li> <li>4 Remove mix, clean, reassemble, sanitize and freeze down.</li> <li>5 See Auto Fill Troubleshooting section.</li> <li>6 Check system. (Call distributor for service)</li> </ol>
<b>Product does not dispense.</b>	<ol style="list-style-type: none"> <li>1 No mix in hopper.</li> <li>2 Drive motor overload tripped.</li> <li>3 Drive belt failure.</li> <li>4 Freeze-up (Auger will not turn).</li> </ol>	<ol style="list-style-type: none"> <li>1 See Auto Fill Troubleshooting section.</li> <li>2 Wait for automatic reset. (If condition continues, call distributor for service.)</li> <li>3 Replace drive belt.</li> <li>4 Turn Clean/Off/On switch Off for 15 minutes, then restart.</li> </ol>
<b>Drive belt slipping or squealing.</b>	<ol style="list-style-type: none"> <li>1 Worn drive belt.</li> <li>2 Freeze-up (Auger will not turn).</li> <li>3 Not tensioned properly.</li> </ol>	<ol style="list-style-type: none"> <li>1 Replace drive belt.</li> <li>2 Turn Clean/Off/On switch Off for 15 minutes, then restart.</li> <li>3 Adjust belt tension</li> </ol>
<b>Rear auger seal leaks.</b>	<ol style="list-style-type: none"> <li>1 Outside surface of rear auger seal is lubricated.</li> <li>2 Rear seal missing or damaged.</li> <li>3 Seal o-ring missing, damaged or installed incorrectly.</li> <li>4 Worn or scratched auger shaft.</li> </ol>	<ol style="list-style-type: none"> <li>1 Clean lubricant from outside of rear seal, lubricate inside of seal and reinstall.</li> <li>2 Check or replace.</li> <li>3 Check. or replace.</li> <li>4 Replace auger shaft.</li> </ol>
<b>Front door leaks.</b>	<ol style="list-style-type: none"> <li>1 Front door knobs are loose.</li> <li>2 Spigot parts are not lubricated.</li> <li>3 Chipped or worn spigot o-rings.</li> <li>4 O-rings or spigot installed wrong.</li> <li>5 Inner spigot hole in front door nicked or scratched.</li> </ol>	<ol style="list-style-type: none"> <li>1 Tighten knobs.</li> <li>2 See Section 3.</li> <li>3 Replace o-rings.</li> <li>4 Remove spigot and check o-ring.</li> <li>5 Replace front door.</li> </ol>

#### 4.3 TROUBLESHOOTING - AUTO FILL SYSTEM

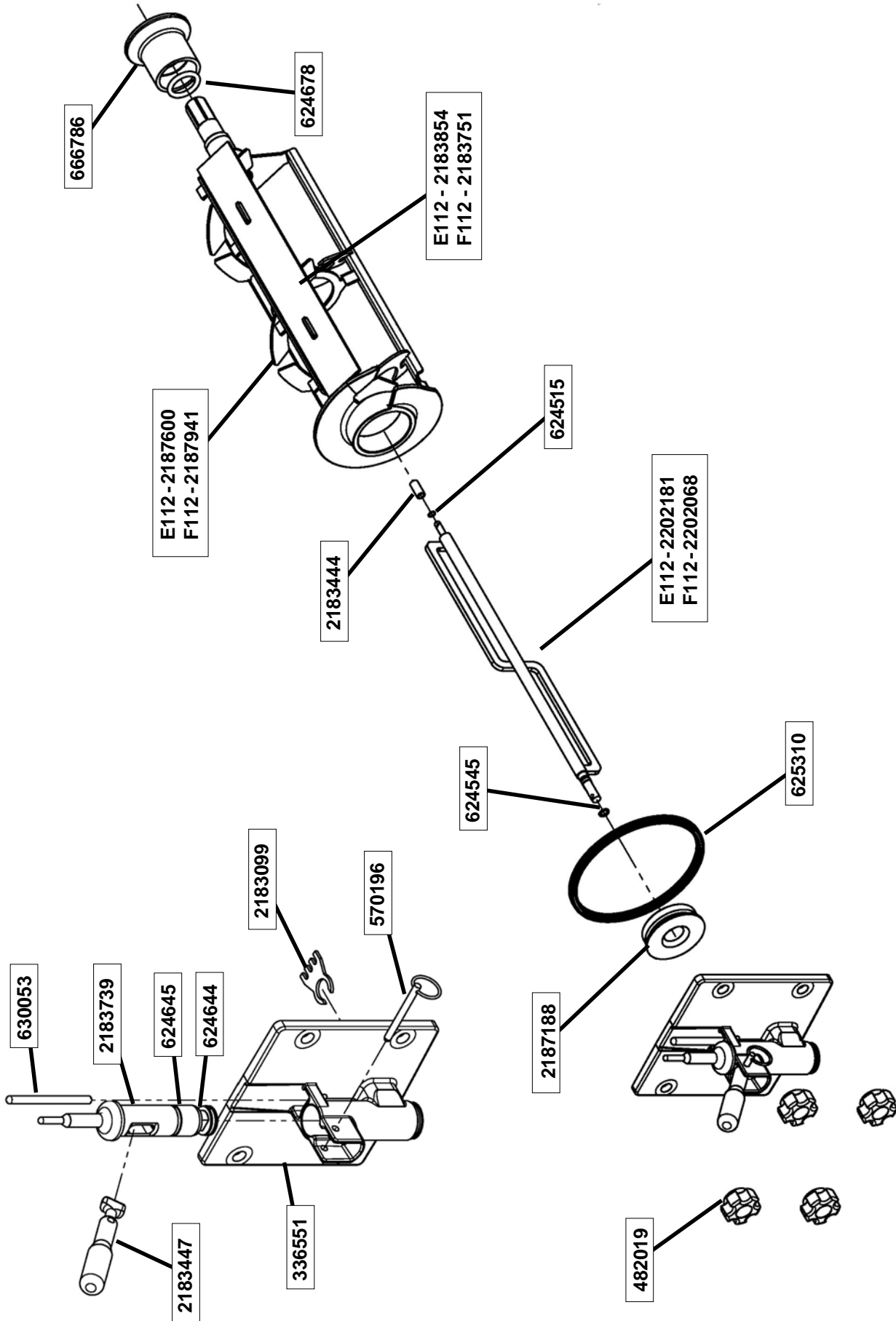
<b>Pump does not operate.</b>	<ol style="list-style-type: none"> <li>1 Low water pressure.</li> <li>2 Restriction or plugged auto fill system.</li> <li>3 Empty BIB</li> </ol>	<ol style="list-style-type: none"> <li>1 Verify that there is adequate water pressure at the inlet fitting (30-50 psi).</li> <li>2 Flush and sanitize the pump and tubing.</li> <li>3 Replace BIB</li> </ol>
<b>Syrup concentration incorrect</b>	<ol style="list-style-type: none"> <li>1 BIB connector is not connected to the BIB properly.</li> <li>2 Leak at the connections or in the tubing.</li> <li>3 Air in the BIB syrup container.</li> <li>4 Pump is clogged with debris or particulates.</li> </ol>	<ol style="list-style-type: none"> <li>1 Check connection and reconnect if necessary.</li> <li>2 Look for leaks at the connections and bubbles in the tubing. Tighten clamps and replace tubing if necessary.</li> <li>3 Remove the air from the BIB syrup container.</li> <li>4 Remove syrup valves and inspect for debris or improper closing that would interfere with operation.</li> </ol>

## SECTION 5 REPLACEMENT PARTS

### 5.1 DECALS AND LUBRICATION

Part	Description	Quantity	
		E112-LJ	F112-LJ
208135	Brush - 4" X 8" X 16" (Barrel)	1	1
208380	Brush - 1/4" X 3" X 14"	1	1
208401	Brush - 1" X 3" X 10"	1	1
236054	Cleaning Card - Auto Fill Pump Kit	1	1
324105	Decal - Caution Electrical Shock	1	1
324106	Decal - Caution Electrical Wiring Materials	1	1
324107	Decal - Caution Hazardous Moving Parts	1	1
324141	Decal - Caution Rotating Blades	1	1
324208	Decal - Attention Refrigerant Leak Check	1	1
324393	Decal - Stoelting Swirl Logo	1	1
324509	Decal - Cleaning Instructions	1	1
324548	Decal - Adequate Ventilation 6"		1
324566	Decal - Wired According To	1	1
324584	Decal - Adequate Ventilation 3"	1	
324686	Decal - Danger Automatic Start	1	1
324804	Decal - Domed Stoelting Swirl (Header Panel)	1	1
324852	Decal - Clean Condenser Filter	1	
324865	Decal - Standby Light	1	1
508048	Lubricant - Spline (2 oz Squeeze Tube)	1	1
508135	Petrol Gel - 4 oz Tube	1	1

## 5.2 AUGER SHAFT AND FACEPLATE PARTS

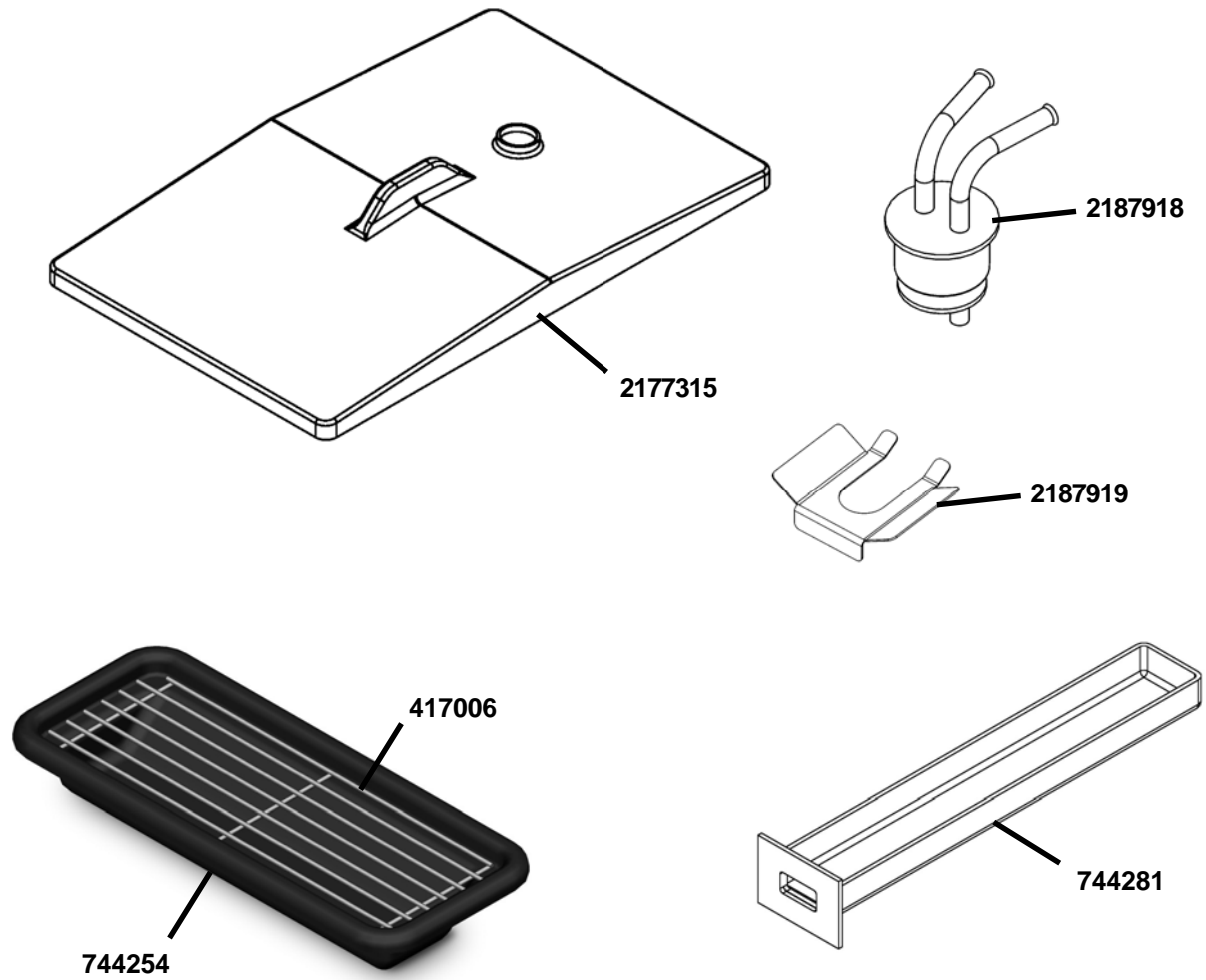




## 5.2 AUGER SHAFT AND FACEPLATE PARTS - CONTINUED

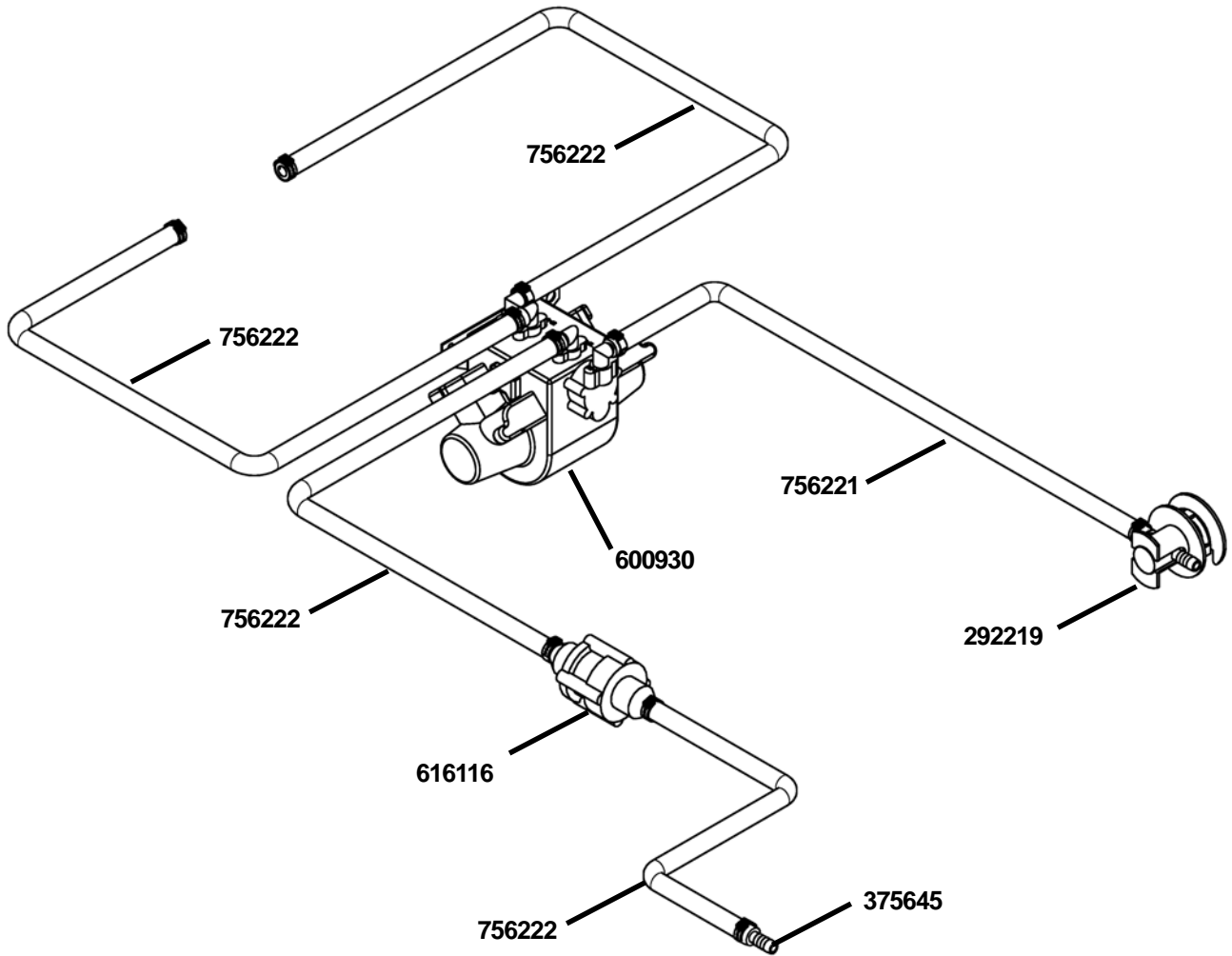
Part	Description	Quantity	
		E112-LJ	F112-LJ
336551	Door - Front	1	1
482019	Knob - Front Door (Black)	4	4
570196	Pin - Cotterless Clevis (Front Door)	1	1
624515-5	O-Ring - Stator Bar Rear (5 Pack)	1	1
624545-5	O-Ring - Stator Bar Front (5 Pack)	1	1
624644-5	O-Ring - Spigot Body (Bottom) (5 Pack)	1	1
624645-5	O-Ring - Spigot Body (Top) (5 Pack)	1	1
624678-5	O-Ring - Rear Seal - Black (5 Pack)	1	1
625310	Quad-Ring - Front Door - Black	1	1
630053	Rod - Torque Actuator	1	1
666786	Seal - Rear Auger - Black	1	1
2183099	Breaker Bar - Spigot Body	1	1
2183444	Bushing - Stator Support (Rear)	1	1
2183447	Handle Only - Spigot	1	1
2183739	Spigot Body	1	1
2183751	Blade - Scraper	1	1
2183854	Blade - Scraper	1	1
2187188	Bushing - Front Auger Support	1	1
2187600	Auger Shaft	1	1
2187941	Auger Shaft	1	1
2202068	Stator Bar	1	1
2202181	Stator Bar	1	1

### 5.3 HOPPER PARTS



Part	Description	Quantity	
		E112-LJ	F112-LJ
396244	Gasket - Freezer Base		1
417006	Grid - Drip Tray (Metal)	1	1
624607-5	O-Ring - Mix Inlet (5 Pack)	2	2
744254	Tray - Drip	1	1
744281	Tray - Drain	1	1
2177315	Cover - Hopper	1	1
2187918	Mix Inlet Assembly	1	1
2187919	Clip - Retaining (Mix Inlet)	1	1

## 5.4 AUTO FILL PARTS



Part	Description	Quantity
264100	Clamp - Oetiker Stepless	25
292219	Connector - Bag In Box	1
375645	Fitting - 3/8" x 3/8"	1
538463	Nut	2
600930	Pump - Brix	1
616116	Water Regulator	1
644359	Screw - 10-32 x 1/2"	2
739126	Tie Wrap - 15"	10
739127	Tie Wrap - 7"	2
756221	Tubing - 3/8" Clear	3'
756222	Tubing - 3/8" Braided	40'





## **LJS IceFlow WARRANTY F112-LJ, E112-LJ and Autofill Mix Brix Pump System**

**1. Scope:**

Stoelting LLC warrants to the first user (the "Buyer") that the evaporator assembly, compressor, drive motor and speed reducer (if applicable) of Stoelting F112-LJ, E112-LJ and Autofill mix brix pump equipment will be free from defects in materials and workmanship under normal use and proper maintenance appearing within five (5) years and that all other components of such equipment manufactured by Stoelting will be free from defects in material and workmanship under normal use and proper maintenance appearing within twenty-four (24) months after the date that such equipment is originally installed.

**2. Disclaimer of Other Warranties:**

**THIS WARRANTY IS EXCLUSIVE; AND STOELTING HEREBY DISCLAIMS ANY IMPLIED WARRANTY OF MERCHANTABILITY OR FITNESS FOR PARTICULAR PURPOSE.**

**3. Remedies:**

Stoelting's sole obligations, and Buyer's sole remedies, for any breach of this warranty shall be the repair or (at Stoelting's option) replacement of the affected component at Stoelting's plant in Kiel, Wisconsin, or (again, at Stoelting's option) refund of the purchase price of the affected equipment, and, during the first twenty-four (24) months (first twelve (12) months for Autofill mix brix pump equipment) of the warranty period, deinstallation/reinstallation of the affected component from/into the equipment. Those obligations/remedies are subject to the conditions that Buyer (a) signs and returns to Stoelting, upon installation, the Warranty Registration Card for the affected equipment, (b) gives Stoelting prompt written notice of any claimed breach of warranty within the applicable warranty period, and (c) delivers the affected equipment to Stoelting or its designated service location, in its original packaging/crating, also within that period. Buyer shall bear the cost and risk of shipping to and from Stoelting's plant or designated service location.

**4. Exclusions and Limitations:**

This warranty does not extend to parts, sometimes called "wear parts", which are generally expected to deteriorate and to require replacement as equipment is used, including as examples but not intended to be limited to o-rings, hoses, seals and drive belts. All such parts are sold

**AS IS.**

Further, Stoelting shall not be responsible to provide any remedy under this warranty with respect to any component that fails by reason of negligence, abnormal use, misuse or abuse, use with parts or equipment not manufactured or supplied by Stoelting, or damage in transit.

**THE REMEDIES SET FORTH IN THIS WARRANTY SHALL BE THE SOLE LIABILITY STOELTING AND THE EXCLUSIVE REMEDY OF BUYER WITH RESPECT TO EQUIPMENT SUPPLIED BY STOELTING; AND IN NO EVENT SHALL STOELTING BE LIABLE FOR ANY INCIDENTAL OR CONSEQUENTIAL DAMAGES, WHETHER FOR BREACH OF WARRANTY OR OTHER CONTRACT BREACH, NEGLIGENCE OR OTHER TORT, OR ON ANY STRICT LIABILITY THEORY.**