

STEAM-TECH *PLUS* ELECTRIC STEAM COOKER STP-6E

OWNER'S MANUAL



Form Number: S-2464

01/07

Printed in U.S.A.



35 Garvey Street • Everett • MA • 02149

Tel: (617) 387-4100 • Toll Free: (888) 698-3188

Fax: (617) 387-4456 • Outside MA Fax: (800) 227-2659

E-Mail: CUSTSERV@mfi.com • Website: www.mfi.com

TABLE OF CONTENTS

1. INTRODUCTION

- 1.1 To The Kitchen Manager1.1
- 1.2 Description.....1.1
- 1.3 Cooking Capacities.....1.1
- 1.4 Basic Functioning1.1
- 1.5 Service.....1.1

2. INSTALLATION

- 2.1 Setting In Place2.1
- 2.2 Service Connections.....2.1
 - 2.2.1 Water Connections2.1
 - 2.2.2 Electrical Connections2.1
- Figure 2.1 Service Connections2.1
- 2.3 Reversing The Doors.....2.2
- Figure 2.2 Domestic & Export Heater Wiring & Ratings2.2

3. INITIAL SYSTEMS INSPECTION

- 3.1 General.....3.1
- Figure 3.1 Controls & Indicators3.1
- 3.2 Warm Up3.1
- 3.3 Steam Demand.....3.1
- 3.4 Steam Mode3.1
- 3.5 Steam & Hold Mode3.1
- 3.6 Constant Steam.....3.1
- 3.7 Steam Suppression3.2
- 3.8 Shut Down3.2

4. OPERATION

- 4.1 Controls & Indicators4.1
- 4.2 Operating Procedures4.1
 - 4.2.1 Start-Up & Preheating4.1
 - 4.2.2 Cooking4.1
 - 4.2.3 Shut Down4.1
- Table 4.1 Controls & Indicators.....4.1
- Figure 4.1 Control Panel.....4.2
- Figure 4.2 Daily Cleaning/Parts List4.3
- 4.3 Daily Cleaning4.4
- 4.4 Prolonged Shut Down & Cleaning.....4.4

5. TROUBLE-SHOOTING

- 5.1 General.....5.1
- Trouble-Shooting Guide5.1
- 5.2 Water Level Control Board5.2
 - 5.2.1 Testing The Water Fill Relay.....5.3
 - 5.2.2 Testing The Low Water Relay.....5.3
- Figure 5.1 Water Level Control Board5.3

6. MAINTENANCE

- 6.1 General.....6.1
- 6.2 Daily Cleaning6.1
- 6.3 Preventive Maintenance6.1
- 6.4 Cleaning The Generator6.1
 - 6.4.1 Cleaning Instructions6.1
- Figure 6.1 Exterior Steel-Metal Cover Panel & Fasteners/Parts List.....6.2
- 6.5 Cleaning The Steam ventilation Ductwork.....6.3
- 6.6 Electrical Box Service Access6.3
- Figure 6.2 Electrical Panel Assembly/Parts List6.4
- Figure 6.3 Timer Settings & Terminal no.'s & Locations/ Relay Terminal Contact no.'s & Locations6.5
- Figure 6.4 Principles of Operation Schematic6.6
- Figure 6.5 Single Compartment System Wiring Diagram6.7
- Figure 6.6 Single Compartment System Wiring Diagram6.8
- 6.7 Control Panel Electrical Service Access.....6.9
- 6.8 Door Adjustment.....6.9
 - 6.8.1 Door Alignment.....6.9
- Figure 6.7 Control Panel Assembly/Parts List6.9
- 6.8.2 Door Latch Tension Adjustment.....6.10
- 6.8.3 Door Handle tension Adjustment.....6.11
- Figure 6.8 Door Latch & Magnet Sensor Assembly/ Parts List.....6.11
- Figure 6.9 Cooking Compartment Door Assembly/ Parts List.....6.12
- 6.9 Door Gasket Replacement6.13
- Figure 6.10 Single Electric Powered Steam Generator Assembly/Parts List6.13
- 6.10 Solenoid Fill Valve Strainer Screen Cleaning6.14
- 6.11 Blower Box Assembly/Parts List6.15
- Figure 6.12 Tempering Tank Assembly/Parts List...6.15
- Figure 6.13 Chassis Assembly/Parts List6.17
- Figure 6.14 tubing Routing/Parts List6.19

1. INTRODUCTION

1.1 TO THE KITCHEN MANAGER

1. Read this manual carefully and in its entirety. Contact Market Forge Ind., Inc. for clarification if necessary.
2. Protect your kitchen personnel from scalding and other serious injury by providing training programs to acquaint all equipment operators with the correct and safe methods of operation.
3. Operators must be made aware of the consequences of misuse. Steam producing equipment, no matter who the manufacturer is inherently dangerous when misused. The possibility of serious scalding always exists, the careless and/or untrained operator will be injured.
4. This equipment must be maintained accordingly to the guidelines in this manual (*see section 6, maintenance*). Lack of maintenance will lead to a potentially hazardous condition and possible liability. Operators should report any equipment malfunction immediately and steps must be taken to correct the problem before further use of the equipment is allowed.
5. Keep this manual for daily reference.

WARNING: IMPROPER INSTALLATION, ADJUSTMENTS, ALTERATION, SERVICE OR MAINTENANCE CAN CAUSE PROPERTY DAMAGE, INJURY OR DEATH. READ THE INSTALLATION, OPERATION AND MAINTENANCE INSTRUCTIONS THOROUGHLY BEFORE INSTALLING OR SERVICING THIS EQUIPMENT.

1.2 DESCRIPTION

The Steam-Tech Plus is a pressureless steam cooker consisting of two independently controlled cooking compartments in a single cabinet. Each compartment has its own independent control panel, consisting of a power switch, mode select switch, constant steam switch, timer (mechanical or electronic), steam demand indicator, and indicator lights for each of its functions. The Steam-Tech Plus is equipped with many unique features and functions. These features and functions will be discussed in greater detail in section 4 on page 4.1.

1.3 COOKING CAPACITIES

Each cooking compartment will accept:

- Three 12" x 20" x 2.5" Pans.

The inside dimensions of the cooking compartments are:

- 14.5" Wide x 10.75" High x 23" Deep, (368mm) W x (273mm) H x (584mm) D

1.4 BASIC FUNCTIONING

Each Steam-Tech Plus cooking compartment has its own independent steam generator. Each of its two cooking compartments may be operated either independently or simultaneously. Each compartment is equipped with identical controls. These controls allow it to be used in the "TIMED STEAM" mode, "CONSTANT STEAM" untimed mode, or the "STEAM & HOLD" mode.

The Steam-Tech Plus utilizes a unique STEAM DEMANDS feature. This feature allows the Steam-Tech Plus to operate at extremely high cooking efficiencies. The Steam Demand System creates only the amount of steam as will be absorbed by the food being cooked, no more and no less. No excess steam is created, therefore, nothing is lost down the drain.

To begin operation, the POWER switch is pressed into the ON position, illuminating the power light. This opens the water feed solenoid valves, to both the steam generator and tempering tank. Once the appropriate water levels have been reached the heating element is energized. When the water temperature

in the steam generator has reached 193°F the green READY light is illuminated indicating that the unit is now ready to make steam and all controls are functional.

Set the MODE SELECT switch to either STEAM or STEAM & HOLD. After selecting a mode the TIMER knob must be set to the desired cooking time for the generator to begin making steam.

In the STEAM mode the unit will create steam for the duration of the time you have set. Once the timer reaches the end of its cycle (*0 minutes*) the unit will stop making steam and the buzzer will sound. The buzzer is silenced by returning the timer knob to the OFF position. The generator will idle at 193°F.

In the STEAM & HOLD mode the unit will create steam for the duration of the time you have set. Once the timer reaches the end of its cycle (*0 minutes*) the unit will stop making steam and go into HOLD mode illuminating the amber hold light. When in the HOLD mode the auxiliary thermostatically controlled electric strip heater is activated. The strip heater is mounted onto the outside of the cooking compartment and will now act as a holding cabinet until you call for steam again. During this time the generator will idle at 193°F.

The CONSTANT STEAM button overrides the MODE SELECT switch and the TIMER. When the button is depressed, the green constant steam light is illuminated. In this mode the generator will create steam indefinitely as controlled by the steam demand system regardless of the MODE SELECT switch and TIMER setting, until the CONSTANT STEAM button is pressed again. While the constant steam button is depressed the timer may be used as an alarm only as it will have no effect on the creation of steam. To exit the constant steam mode the constant steam button must be pressed again. This will cause the green constant steam light to go off. The generator will now idle at 193°F ready to make steam.

All drainage is routed through the common tempering tank, which regulates the drain water temperature. This tank cools the drain water to 130°F before discharging it down the main drain line.

1.5 SERVICE

Required service both preventive and corrective is explained in section 7 of this manual. Should repairs be required, a network of authorized agencies is available to assist with prompt service. A current directory of authorized service agencies may be obtained by contacting our factory direct or going on our web site:

Market Forge Industries Inc.
35 Garvey Street
Everett, MA 02149
Tel: (888) 698-3188
www.mfii.com

The model and serial numbers must be referenced when corresponding with Market Forge. The data plate containing the serial number is located on the top of the unit. The model number is located either on the control panel or front of the unit.

NOTE: It is the owner/manager's responsibility to provide instruction to kitchen equipment operators. The instruction must include the safe operation of all equipment. Operators must report malfunctioning equipment immediately so the equipment can be taken out of service and repaired.

2. INSTALLATION

2.1 SETTING IN PLACE

The assembled Steam-Tech Plus Pressureless Steam Cooker is shipped bolted to a skid, with the cabinet feet shipped in a separate container. Steps required for assembly are as follows:

1. Remove the four bolts which secure the unit to the skid.
2. Install the feet into the threaded mounting locations on the bottom of the unit.
3. Mount the left and right pan support racks on the mounting brackets location inside each of the cooking compartments. **NOTE: The racks with the metal baffling mount on the right (steam inlet) side of the cooking compartment.**
4. If possible, a location should be selected under an exhaust hood which will remove small amounts of vapors emitted from the cooker during normal operation.
5. Level the unit after it is placed in its final location. This is accomplished by turning the bottom part of the adjustable feet. Using the cabinet top as a reference, obtain level adjustment left-to-right and front-to-back.
6. Remove all instructional materials from the cooking compartments and leave both doors ajar.

CAUTION:

- This application, when installed must be electrically grounded in accordance with local codes, or in the absence of local codes, with the National Electric Code, ANSI/NFPA70-Latest Edition, Canada CSA C22.1 Canadian Electrical Code Part 1 and or local codes.
- This unit is serviceable from the front. Do not install in such a manner that a service person cannot remove the front panel.
- Keep this manual for future reference.

2.2 SERVICE CONNECTIONS

All service connections are made at the bottom of the unit, in the 6 inch high space between the floor and the bottom of the cabinet. Please see figure 2.1 and table 2.1 for service connections, details and dimensions.

2.2.1 WATER CONNECTIONS

Before connecting the water to this unit, have water supply analyzed to make sure that hardness is no greater than 2.0 grains per gallon and pH level is within the range of 7.0–8.5. Water that fails to meet these standards should be treated by the installation of a water conditioner. **EQUIPMENT FAILURE CAUSED BY INADEQUATE WATER QUALITY IS NOT COVERED UNDER WARRANTY.**

CAUTION: PVC AND CPVC PIPE ARE NOT ACCEPTABLE MATERIALS FOR DRAINS.

Please see figure 2.1 and table 2.1 for service connections, details and dimensions.

2.2.2 ELECTRICAL CONNECTION

Note that this unit has more than one electrical service connection. Please see figure 2.1 and table 2.1 for service connections, details and dimensions.

CAUTION: USE COPPER WIRE ONLY FOR POWER SUPPLY CONNECTIONS.

ELECTRICAL CONNECTIONS AND SERVICE MUST BE MADE BY A LICENSED ELECTRICIAN.

SERVICE CONNECTIONS - Electrically Operated

EP	Power Supply - Use wire suitable for at least 90°C.		
	Volts	Phase	Amps
	208	1	86.6
	208	3	50.0
	240	1	75.0
	240	3	43.5
480	1	37.5	
	3	22.0	
EC	Electrical Connection - 1/2" VAC, 60 Hz, 1/2" conduit or equivalent. Current draw for 120V control circuitry is 6.5 amps. Use wire suitable for at least 90°C.		
CW	Cold Water - 1/2" NPT male to cold water supply manifold. Cold water supply line to have a maximum of 50 PSI (3.5 kg/cm ²) and a minimum of 25 PSI (1.8 kg/cm ²) water pressure.		
D	Drain - 1 1/2" O.D. pipe coupled to 1 1/2" O. D. tempering tank drain. Do not make solid connection to floor drain.		

TABLE 2.1 SERVICE CONNECTIONS

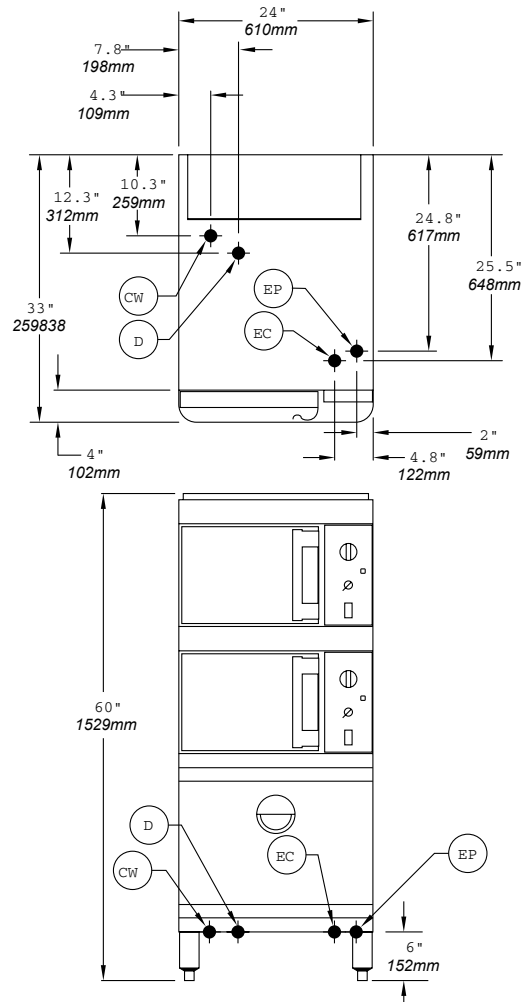

FIGURE 2.1 SERVICE CONNECTIONS

2. INSTALLATION

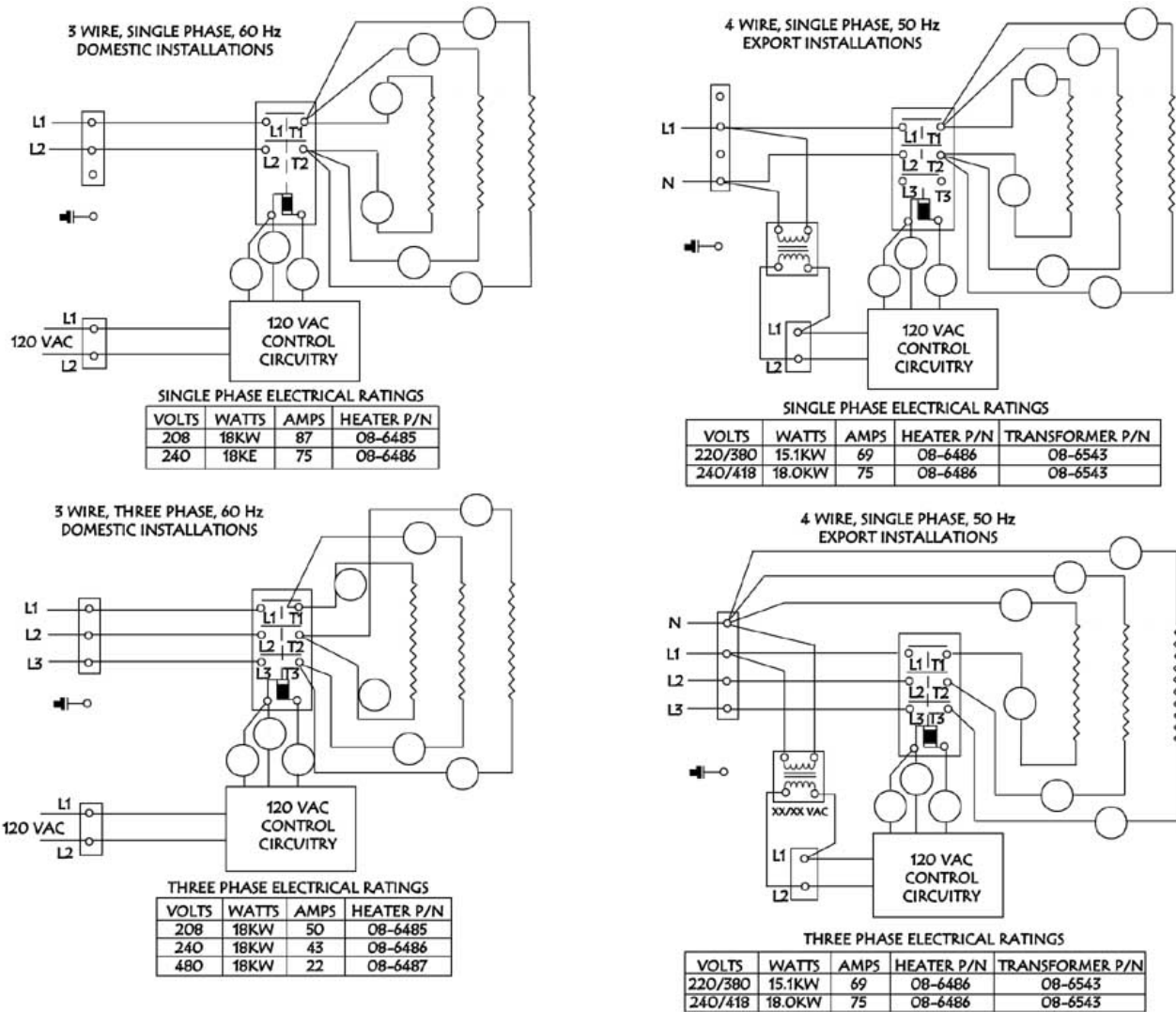

FIGURE 2.2 DOMESTIC & EXPORT HEATER WIRING & RATINGS

2.3 REVERSING THE DOORS

The Steam-Tech Plus Pressureless Steam Cooker has cooking compartment doors which are reversible, for your convenience. For door assembly illustration and table, refer to page 6.12.

NOTE: This procedure is identical for both the upper and lower cooking compartments doors.

1. Remove the left large side panel by removing the screw from the center of the bottom edge of the panel. Gripping one of the louvers, slide the panel upwards until the bottom edge of the panel is free to swing out slightly away from the unit. Slide the panel down until its top edge is clear of the top cap of the unit.
2. Open cooking compartment door.
3. Remove the two 5/16" bolts that attach the top hinge to the front of the unit.
4. Slide the door upwards off the bottom hinge.
5. Remove the two 5/16" bolts that attach the bottom hinge to the front of the unit. NOTE: The top hinge is slightly larger than the bottom hinge.
6. Remove the 4 black plastic hole plugs from the front unit. Push the black hole plugs into the now vacant left upper and lower hinge mounting holes.
7. Reinstall the top (*larger*) hinge and bolts into the right lower hinge mounting holes. Rotate the hinge 180° for installation, so that the pin which the door rides on is now facing up.
8. Remove the door latch assembly from the face of the unit. The two door latch mounting nuts are located behind the face of the unit and must be accessed by removing the large side panels.
9. Remove the two white hole plugs from the left door latch mounting holes and insert them into the right door latch mounting holes (*where the door latch assembly was originally mounted*).
10. Rotate the door latch assembly 180° and install into the

2. INSTALLATION

left door latch mounting holes.

11. To adjust the tension of the door latch tighten both nuts down until the springs are fully compresses then back each nut off 1/2 turn.
12. Replace large side panel by placing the panel against the side of the unit. Be sure that the top edge of the side panel slides under the top cap of the unit. Slide the panel upwards until it stops. Then, while pushing the panel in towards the unit slide it down into position. Replace screw.
13. Rotate the door 180° for mounting.
14. Slide the remaining (*small*) hinge into the top door bearing.
15. Slide the door and hinge assembly down onto the hinge which you have already mounted to the front of the unit. Use the two 5/16" bolts to mount the top hinge into the right upper hinge mounting holes. **DO NOT COMPLETELY TIGHTEN THE HINGE MOUNTING BOLTS YET.** These are used later for door adjustment.
16. Door adjustment is covered in section 6.8 on page 6.9.

3. INITIAL SYSTEMS INSPECTION

3.1 GENERAL

This section contains information for you to test and familiarize yourself with the operation of the Steam-Tech Plus.

After the unit is completely assembled all packing materials removes and all service connections are made, all systems must be gives a thorough check out before being put into operation. Be sure that the cooking compartments are empty and all pan support racks are in place. Confirm that all service connections are on. Select a cooking compartment to test. Close the cooking compartment door and turn the timer knob to the OFF position.

Illustration of the positions for the controls and indicators.

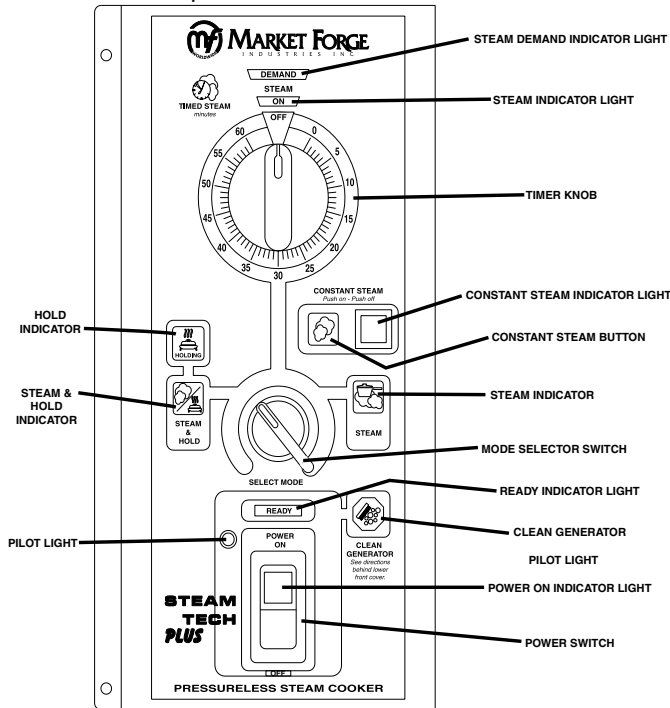

FIGURE 3.1 CONTROLS & INDICATORS

Note that your unit may come equipped with an independent POWER ON indicator located to the left of the power switch.

NOTE: REPEAT STEPS IN SECTION 3.2 THROUGH 3.7 FOR BOTH THE UPPER & LOWER COOKING COMPARTMENTS TO INSURE PROPER FUNCTIONING OF THE ENTIRE UNIT.

3.2 WARM UP

Push the POWER switch into ON position. The power light will come on immediately, along with the fan motor. You will hear water entering the unit through the solenoid valves filling both the steam generator and the tempering tank.

Once the water levels in the steam generator and tempering tank have reached the appropriate level the solenoid valves will close and the heater will energize. After a short time (approximately 5 minutes, depending on heater voltage), the green READY light will come on, indicating that the unit is ready to make steam.

3.3 STEAM DEMAND

Due to the unique nature of this design, it is important to understand what the STEAM DEMAND system does. The STEAM

DEMAND system is the means by which the Steam-Tech Plus monitors and creates steam. This system uses very sensitive sensors to monitor the minute steam fluctuations inside the cooking compartment. These fluctuations are an indicator of how much steam energy the food inside the cooking compartment is using. The sensors control the heater, insuring that steam is creates only as fast as it will be accepted by the food inside the cooking compartment, no more no less.

The system can be monitored by observing the red STEAM DEMAND indicator, located at the top of the control panel. The STEAM DEMAND indicator will light up red only when steam is called for and will cycle on an off throughout the cooking cycle.

3.4 STEAM MODE

Turn the MODE SELECT switch to the STEAM mode. Set the TIMER knob to 10 minutes. Immediately, the STEAM ON window, located near the top of the control panel, should light up green. At the same time, the STEAM DEMAND window should light up red. After a short time, the red STEAM DEMAND light will begin to cycle on and off, while the green STEAM ON light stays on continuously.

When the timer reaches 0 minutes, the buzzer will sound and both the STEAM ON and the STEAM DEMAND light will turn off. The buzzer is silenced by returning the TIMER knob to the OFF position. The green READY light will stay illuminated.

3.5 STEAM & HOLD MODE

Turn the MODE SELECT switch to the STEAM & HOLD mode. Set the TIMER knob to 10 minutes, immediately the STEAM ON window located near the top of the control panel, should light up green. At the same time, the STEAM DEMAND window should light up red. After a short time, the red STEAM DEMAND light will begin to cycle on and off, while the green STEAM ON light stays on continuously.

When the timer reached 0 minutes, the buzzer will sound and both the STEAM ON and the STEAM DEMAND lights will turn off. The buzzer is silenced by returning the TIMER knob to the OFF position. The green READY light will stay illuminated.

While the HOLD light is on, the cooking compartment will function as a holding cabinet, maintaining a safe food holding temperature of approximately 160°F indefinitely. Each of the cooking compartments has its own independent temperature gauge. The cooking compartment temperature gauges are mounted on the right hand side of the steam vent hoods, directly above the control panel for each of the cooking compartments.

3.6 CONSTANT STEAM MODE

The CONSTANT STEAM button overrides all other cooking mode. When the CONSTANT STEAM button is depressed, the CONSTANT STEAM window, located next to the CONSTANT STEAM button will light up green.

Immediately the STEAM ON window, located near the top of the control panel, should light up green. At the same time, the STEAM DEMAND window should light up red. After a short time the red STEAM DEMAND light will begin to cycle on and off, while the green STEAM ON light remains illuminated continuously.

NOTE: Even in the constant steam mode the heater will only create as much steam as will be accepted by the food inside the cooking compartment. No matter what mode has been selected the red STEAM DEMAND indicator will cycle on and off.

3. INITIAL SYSTEMS INSPECTION

CAUTION: THE TIMER IS USEFUL ONLY AS AN ALARM WHEN IN THE CONSTANT STEAM MODE. THE TIMER WILL COUNT DOWN, BUT IT WILL HAVE NO EFFECT ON THE CONTINUOUS GENERATION OF STEAM, AS IT WILL BE OVERRIDDEN BY THE CONSTANT STEAM BUTTON.

3.7 STEAM SUPPRESSION

The proper operation of the steam suppression system is evidenced by the lack of steam billowing out of the cooking cavity when the door is opened. While the generator is creating steam, open the door to the cooking compartment. As soon as the door is opened, a solenoid valve will open sending water to a spray nozzle inside the steam generator. You should hear the spray for approximately 3 to 4 seconds. At the same time, both the STEAM ON and STEAM DEMAND lights will turn off. The green READY light will stay on.

Also, when the door is opened, any residual steam will be drawn up into the steam vent hood. The steam vent hoods are located above each cooking compartment.

When the door is closed the STEAM ON and STEAM DEMAND windows will light up again. At the same time, a bubbling sound will be heard as the cool air is evacuated from the cooking compartment and replaced with a fresh steam from the generator. The unit will continue to cycle normally, as it was before the door

was opened.

NOTE: Repeat steps in section 3.2 through section 3.7 for both the upper and lower cooking compartments to insure proper functioning of the entire unit before proceeding to the next section (shutdown).

3.8 SHUT DOWN

No special procedure is necessary for shutting the unit down. Simply press the POWER switch into the OFF position. All indicator lights on the control panel will go out and the generator for the cooking compartment will drain. The tempering tank will not drain until both POWER switches are in the OFF position.

CAUTION: WHEN THE UNIT IS NOT IN USE, LEAVE BOTH COOKING COMPARTMENT DOORS SLIGHTLY AJAR TO EXTEND THE LIFE OF THE DOOR GASKETS.

Please note that the TIMER should be in the OFF position and the CONSTANT STEAM should be disengaged upon restarting the unit to avoid any unintentional generation of steam on start up.

NOTE: As a final test of the unit before use in cooking food, both generator should be shut down allowing both the generator and tempering tank to completely drain.

4. OPERATION

4.1 CONTROLS AND INDICATORS

The controls and indicators used to operate that Steam-Tech Plus pressureless steam cooker are listed and described in table 4.1 on this page. Their locations are called out in Figure 4.1 on page 4.2.

4.2 OPERATING PROCEDURES

This section includes general instructions for daily operation of the Steam-Tech Plus. You should review section 3.1 through 3.8 of this manual if you are unfamiliar with the functions of the unit. If you require more detailed technical information contact our factory to find your Market Forge Authorized Service Agency or go to our web site www.mfii.com and look under service.

4.2.1 STAR-UP AND PREHEATING

The Steam-Tech Plus pressureless steam cooker requires no start-up procedure. Simply press the POWER switch into the ON position. The tempering tank and selected cooking compartment's steam generator will fill with water, once full, the heater will automatically preheat the water in the generator to 193°F. This will take approximately 5 minutes. When the generator is ready to create steam the green READY light will come on.

4.2.2 COOKING

NOTE: *The green READY light must be on before any controls become operational.*

- Slide pans of food into the cooking compartment on the pan support racks, or place smaller portions of food in containers onto the perforated a-la-cart tray.
- Firmly close cooking compartment door.
- Select a cooking cycle, either timed or untimed.
- For timed cooking, set the MODE SELECT switch to the desired cooking mode and set the TIMER to the desired cook time.
- At the end of a timed cook cycle (*when the timer has timed out to "0"*), return the TIMER knob to the OFF position to either silence the buzzer (*when using the STEAM mode*), or Exit the HOLD function (*when using the STEAM & HOLD mode*).
- For untimed cooking, press the CONSTANT STEAM button to override the TIMER and create continuous untimed steam.
- When using the untimed cooking cycle, and you have determined that the food in the cooking compartment is done, press the CONSTANT STEAM button again to exit the CONSTANT STEAM mode.
- In any cooking cycle or mode, the STEAM DEMAND light will come on and off. This indicates the automatic creation of steam as it is called for by the food being cooked.

CONDENSATE WARNING:

Normal steam cooking conditions will create some condensate due to temperature differences between the steam and the objects/surfaces in contact. When an excessive volume of condensate appears in the cooking compartment, the steam generator water level control should be checked for possible malfunction and the need for maintenance. Continued use of the equipment without maintenance will create a potential for scalding.

4.2.3 SHUT DOWN

No special procedure is necessary for shutting the unit down. Simply press the POWER switch into the OFF position. All indicator lights on the control panel will go out and the generator for the cooking compartment will drain. The tempering tank will not drain until both POWER switches are in the OFF position.

When a cooking compartment is not in use be sure to leave its door slightly ajar to extend the life of the cooking compartment door gasket. When the unit is completely shut down both cooking compartment doors should be left ajar.

TABLE 4.1 CONTROLS AND INDICATORS

Power Switch	Located at the bottom of the control panel. Pressing this switch into the on position will supply power to unit and activate the corresponding system. Pressing this switch into off position will cut off power to the corresponding system and shut down the unit.
Power Indicator	Located in the body of the power switch. Lights up red when the power switch is pressed into the on position.
Ready Light	Located above the power switch. Lights up green when the corresponding generator has warmed up indicating that it is ready to create steam.
Mode Selector Switch	Located in the center of the control panel, just above the ready light. Turn the switch to the right to select the steam mode. Turn the switch to the left to select the steam and hold mode.
Timer Knob	Located near the top of the control panel. Turn the timer knob clockwise to set the cook time.
Steam On Indicator	Located near the top of the control panel. Lights up green when any cooking mode is active.
Steam Demand Indicator	Located above the steam on indicator. Lights up red as the product you are cooking calls for steam. It will cycle on and off at varying rates depending on the quantity and product being cooked.
Hold Indicator	Located near the center of the control panel on the left side. Lights up amber when the unit is in the hold mode.
Temperature Gauge	Located on the right side of each of the steam hoods, above the control panel. They are used to monitor the internal temperature of the cooking compartments during the hold mode.
Constant Steam Switch	Located near the center of the control panel on the right side. Press the button once to engage it and enter the constant steam mode. Press it again to disengage it and exit constant steam mode.
Constant Steam Indicator	Located next to the constant steam button. Lights up green whenever the unit is in the constant steam mode.
Clean Generator Warning Indicator	Located in the lower right side of the control panel. This will light up red when the generator needs to be delimed.

4. OPERATION

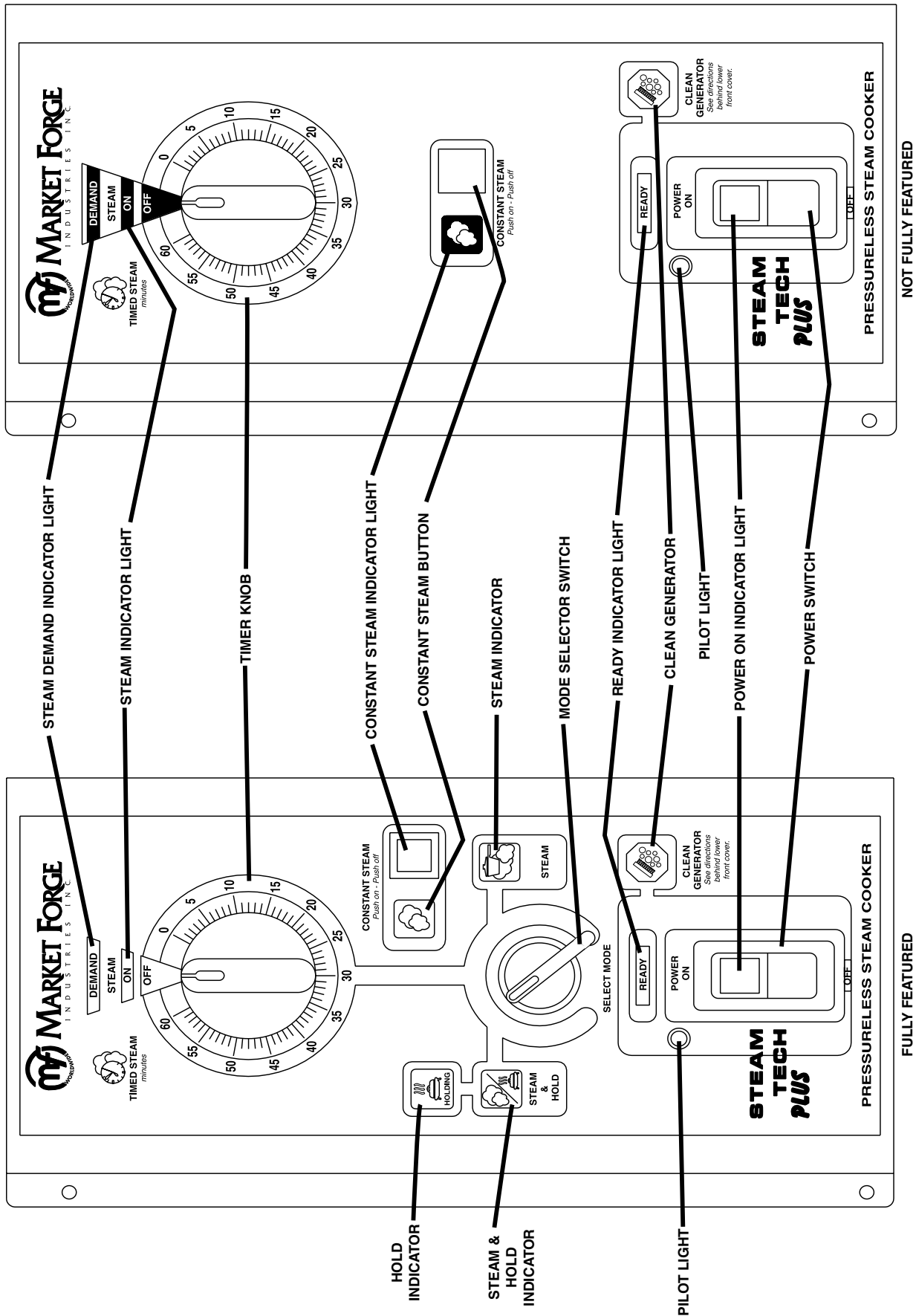

FIGURE 4.1 CONTROL PANEL

4. OPERATION

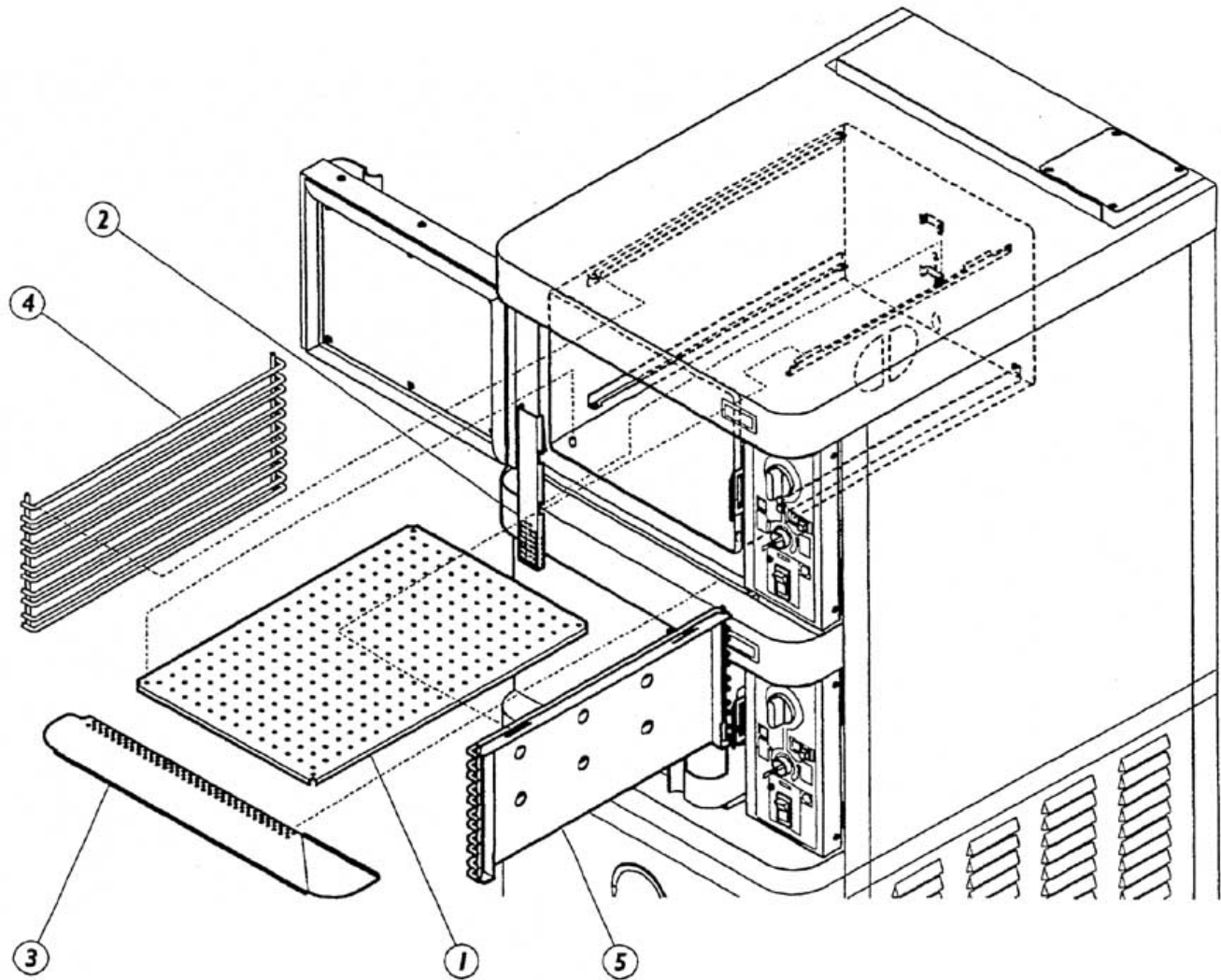

FIGURE 4.2 DAILY CLEANING (SINGLE COOKING COMPARTMENT SHOWN)

ITEM NO.	DESCRIPTION	UPPER COMPARTMENT QTY.	LOWER COMPARTMENT QTY.	PART NO.
1	A-LA-CARTE TRAY	1	1	E91-5782
2	COOKING COMPARTMENT DRAIN SCREEN	1	1	E91-5718
3	DRIP/SPILL TROUGH SCREEN	1	1	E91-5769
4	LEFT PAN SLIDE	1	1	E91-5700
5	RIGHT PAN SLIDE	1	1	E91-5698

4. OPERATION

4.3 DAILY CLEANING

After each period of daily operation (*more frequently as required to maintain cleanliness*) the cooker should be thoroughly cleaned completing the following steps:

1. Remove the left and right side pan support racks by lifting them up off their mounting brackets.
2. Remove the a-la-carte tray from the floor of the cooking compartment by lifting the front of the tray off the mounting pins and sliding it forward.
3. Remove the drain screen from the rear wall of the cooking cavity by sliding it up off its mounting tabs.
4. Wash cooking compartment interior using detergent and water. Rinse and dry thoroughly.
5. Remove upper and lower drip/spill trough screens. Lift the left side of the screen up and swing it out away from the face of the unit until it is free to slide out from under the control panel housing.
6. Wash all removed pieces with a detergent, using a brush and rinse. These pieces can also be sent through a commercial automatic dishwasher. Set these pieces aside for reassembly.
7. Replace the drip/spill trough screens by sliding the right side of the screens under the control panel housing. Then swing the left hand side of the screen in towards the face of the unit until the screen is free to drop down into position.
8. Replace drain screen onto rear wall of cooking compart-

ment by sliding it down onto its mounting tabs.

9. Replace a-la-carte tray by sliding it back until it drops down onto its mounting pins.
10. Replace pan supports into cooking cavity by hanging them on their mounting brackets. Be sure to hang the support with the metal baffling on it on the right side (steam inlet opening) side of the cooking cavity.

4.4 PROLONGED SHUT DOWN AND CLEANING

1. Press both POWER switches OFF, the steam generator and tempering tank will automatically drain.
2. Clean the cooking compartment as described in section 4.3.
3. The steam generator must be rinsed and drained, refer to section 6.4 on page 6.1 for complete instructions.

CAUTION:

- Disconnect the power supply to the steam generators before servicing.
- Contact the factory for authorized service agency or go to our web site www.mfii.com under service for maintenance or repairs.
- Keep this manual for daily reference.

5. TROUBLE-SHOOTING

5.1 GENERAL

The information in this section is intended to assist the operator, maintenance and the service personnel in locating the source of problems which may occur with the cooker. Before following any of the procedures given in this section the operator/maintenance person should be thoroughly familiar with the "Operation" section of this manual.

If the problem cannot be readily corrected without the use of tools, the operator/maintenance person should contact the factory for authorized service agency or go to our web site www.mfii.com under service for maintenance or repairs.

POSSIBLE CAUSE	REMEDY
POWER LIGHT DOES NOT COME ON WHEN POWER SWITCH IS PRESSED TO ON.	
<ol style="list-style-type: none"> No. 120v power to unit. Fuse blown. Faulty POWER switch. 	<ol style="list-style-type: none"> Be sure 120v power supply is on. Replace fuse. Check/replace POWER switch.
WATER ENTERS THE GENERATOR AND/OR TEMPERING TANK VERY SLOWLY.	
<ol style="list-style-type: none"> Dirty strainer screen in the water fill solenoid valve. Dirty or lime accumulation on seat of water fill solenoid valve. 	<ol style="list-style-type: none"> Clean/replace strainer screen. Clean valve seat.
STEAM GENERATOR WILL NOT FILL.	
<ol style="list-style-type: none"> Faulty generator fill solenoid valve. Faulty generator drain solenoid valve. 	<ol style="list-style-type: none"> If 120v is verified at the solenoid coil, but the valve fails to open, replace solenoid. If 120v is verified at the solenoid coil, but the valve fails to close, replace solenoid.
TEMPERING TANK WILL NOT FILL.	
<ol style="list-style-type: none"> Fuse blown. Faulty tempering tank fill/cool solenoid valve. Faulty tempering tank drain solenoid valve. 	<ol style="list-style-type: none"> Replace fuse. If 120v is verified at the solenoid coil, but the valve fails to open, replace solenoid. If 120v is verified at the solenoid coil, but the valve fails to close, replace solenoid.
HEATER WILL NOT ENERGIZE.	
<ol style="list-style-type: none"> Faulty generator water level controls. Heater thermal fusible link blown. 208/240/480 power supply is not connected or not turned on. 	<ol style="list-style-type: none"> See section 5.2 on page 5.2. Replace thermal fusible link. Check to be sure 208/240/480 power is connected and on.
READY LIGHT WILL NOT COME ON.	
<ol style="list-style-type: none"> Faulty 190°F generator thermostat. 	<ol style="list-style-type: none"> Check/replace thermostat.
GENERATOR WILL NOT CREATE STEAM (STEAM ON LIGHT DOES NOT COME ON).	
<ol style="list-style-type: none"> 208/240/480 power supply is not connected or not turned on. Cooking compartment door is ajar. Cooking compartment door out of alignment. Faulty door magnet or magnetic reed switch. Faulty circuit breaker. Faulty heater relay. Faulty pressure switch. Faulty control panel TIMER. Faulty MODE SELECT switch. Faulty CONSTANT STEAM button. 	<ol style="list-style-type: none"> Check to be sure 208/240/480 power is connected and on. Check to be sure that the cooking compartment door is closed and latched. Check to be sure cooking compartment door is properly aligned. Check magnet and reed switch. Replace if needed. Check circuit breaker at your 208/240/480 volt service connection. Reset if necessary. Check/replace heater relay if necessary. Check/replace pressure switch if necessary. Check/replace control panel TIMER if necessary. Check/replace MODE SELECT switch if necessary. Check/replace CONSTANT STEAM button if necessary.

5. TROUBLE-SHOOTING

GENERATOR CONTINUOUSLY CREATES STEAM (STEAM DEMAND LIGHT IS ALWAYS ON)	
<ol style="list-style-type: none"> 1. Cooking compartment door out of alignment. 2. Cooking compartment door gasket leaky. 3. Pressure switch disconnected. 4. Faulty pressure switch (contacts fail to close), 5. Leaky cooking compartment drain line. 6. Steam trap failed to open.* 7. Loss of water seal due to low water or no water in tempering tank.* 	<ol style="list-style-type: none"> 1. Check alignment of door. Realign if necessary. 2. Check/replace door gasket. 3. Check to be sure all pressure switch connections are made. 4. Check/replace pressure switch. 5. Check to be sure cooking compartment drain line is sealed. Replace if necessary. 6. Check/replace steam trap. 7. See "Tempering tank will not fill" on previous page.
STEAM SUPPRESSION NOT FUNCTIONING (EXCESS STEAM COMES OUT OF THE COOKING COMPARTMENT WHEN THE DOOR IS OPEN).	
<ol style="list-style-type: none"> 1. Dirty strainer screen in the spray nozzle solenoid valve. 2. Dirty or lime accumulation in the generator spray nozzle. 3. Faulty timer which controls spray nozzle water solenoid valve. 4. Misaligned ventilation ductwork. 5. Blower not running. 6. Faulty wiring. 	<ol style="list-style-type: none"> 1. Clean or replace strainer screen. 2. Clean generator spray nozzle. 3. Check to be sure that timer is set properly and works. If it doesn't work, replace it. 4. Check ductwork and realign where necessary. 5. Check/replace fuse and be sure that the blower motor works. If not replace blower. 6. Check wiring.
GENERATOR CONTINUES TO CREATE STEAM WHEN THE COOKING COMPARTMENT DOOR IS OPEN.	
<ol style="list-style-type: none"> 1. Faulty magnet reed switch (<i>contacts failed to close</i>). 2. Faulty wiring. 	<ol style="list-style-type: none"> 1. Check magnetic reed switch. Replace if necessary. 2. Check wiring.
TEMPERING TANK DRAIN WATER TEMPERATURE TOO HIGH.	
<ol style="list-style-type: none"> 1. Faulty 130°F thermostat in the tempering tank. 2. Faulty tempering tank/fill cool solenoid valve. 3. Faulty wiring. 	<ol style="list-style-type: none"> 1. Check thermostat, replace if necessary. 2. If 120v is verified at the solenoid coil, but the valve fails to open, replace solenoid. 3. Check wiring.
GENERATOR DOESN'T DRAIN WHEN THE POWER SWITCH IS PRESSED INTO OFF POSITION.	
<ol style="list-style-type: none"> 1. Clogged or kinked generator drain line. 2. Clogged generator drain hole. 3. Faulty generator solenoid drain valve. 	<ol style="list-style-type: none"> 1. Check to be sure that the generator drain line is not kinked and is free of debris. 2. Check to be sure the generator drain hole is free of debris. 3. Rebuild or replace generator solenoid drain valve.
TEMPERING TANK DOESN'T DRAIN WHEN BOTH POWER SWITCHES ARE IN OFF POSITION.	
<ol style="list-style-type: none"> 1. Clogged tempering tank drain line. 2. Clogged tempering tank drain hole. 3. Faulty tempering tank solenoid drain valve. 	<ol style="list-style-type: none"> 1. Clean or replace tempering tank drain line. 2. Check to be sure that the tempering tank drain hole is free of debris. 3. Rebuild or replace tempering tank solenoid drain valve.
CLEAN GENERATOR LIGHT STAYS ON AFTER IT HAS BEEN CLEANED (DELIMED) AND RINSED.	
<ol style="list-style-type: none"> 1. Faulty or incorrectly set CLEAN GENERATOR timer. 2. Faulty CLEAN GENERATOR relay. 3. Faulty wiring. 	<ol style="list-style-type: none"> 1. Check to be sure timer is set correctly. Replace if necessary. 2. Check/replace if necessary. 3. Check wiring.

5.2 WATER LEVEL CONTROL BOARD

The dual function water level controller is two controls on one board. One controller maintains correct water level in the boiler, and the other is low water safety cutoff.

The following trouble-shooting procedure will only determine if the water level control board is working properly, it will not determine why the board has failed.

This procedure exposes you to a shock hazard and must be performed only by a qualified service agent.

NOTE: Improperly connected or malfunctioning water level controller may damage the steam generator due to low water, or create a scalding hazard to the operator due to hot water overflow condition.

TOOLS REQUIRED:

- A digital or analog volt meter capable of reading 120 volts A. C.
- Jumper wire with alligator clips.

5. TROUBLE-SHOOTING

PROCEDURE:

1. Turn off all power to the unit.
2. Select the controller to be tested. Inside the electrical panel the water level control for the top cooking compartment is at the top of the electrical panel and wires to the controller will have an "A" after the wire numbers. The controller for the electrical panel and its wires will have a "B" suffix. In this test procedure, reference to the wire "A" or "B" suffix will be omitted. Refer below to Figure 5.1 for relay locations and terminal identification.
3. Remove the wires #40, 41 and 42 from the terminal connectors "G", "H" and "LLOC". **WARNING: WHEN YOU TURN THE POWER ON, THERE ARE TERMINALS THAT CARRY 120V. PROTECT THE ENDS OF THESE DISCONNECTED WIRES TO PREVENT SHORTING TO HOT LEADS.**
4. Turn power ON. Using the voltmeter, check that power being supplied to terminals L1 and L2 is 120v plus 10% minus 15%.

2. Connect the jumper to terminals "G" and "H". After a delay of 4-5 seconds, the relay should switch and the LED will go OFF. Using the voltmeter touching the probes to terminals L2 and N. O. of the water fill relay should show no voltage. Touching the probes L2 and N. C. should show 120v.
3. Disconnect the jumper.

5.2.2 TESTING THE LOW WATER RELAY

5.2.1 TESTING THE WATER FILL RELAY

1. When the power is turned on, the LED (light emitting diode) next to the water fill relay should be on. Using the voltmeter touching the probes to terminals L2 and N. O. next to the water fill relay should show 120v. Touching the probes to L2 and N. C. should show no voltage.

1. With the power on, the LED next to the low water relay should be off. Using the voltmeter touch probes to the L2 and N. O. terminals next to this relay, there should be no voltage. Touching the probes to terminals L2 and N. C. should show 120v.
2. Connect the jumper to terminals "G" and "LLOC". The LED next to the low water relay should turn on immediately.
3. Touch the voltmeter probes to terminals L2 and N. O. next to the low water relay there should be 120v. Touch the probes to terminals L2 and N. C. there should be no voltage.
4. Remove the jumper and turn off power. Reconnect the disconnected wires; wire #41 to terminals "G", wire #42 to terminal "LLOC", and wire #43 to terminal N. C. of the water fill relay.

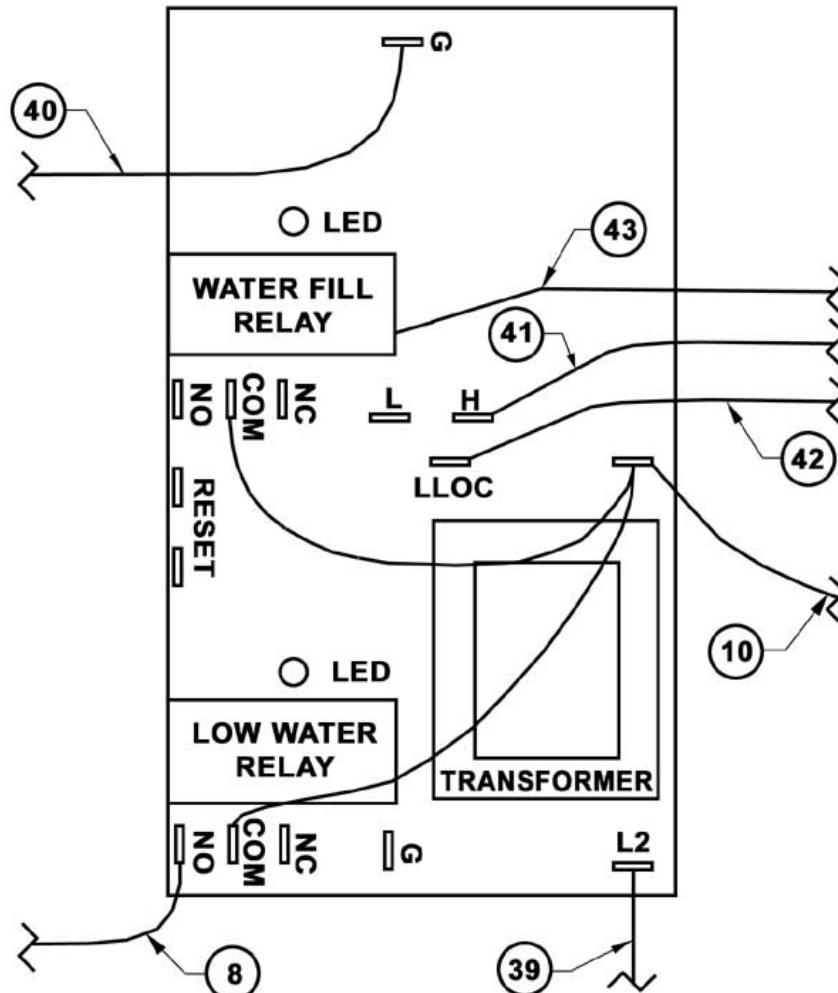

FIGURE 5.1 WATER LEVEL CONTROL BOARD

6. MAINTENANCE

6.1 GENERAL

This section contains both preventive and corrective maintenance information. Preventive maintenance may be performed by maintenance personnel at the establishment in which to cooker is installed. It is recommended that user personnel never attempt to make repairs or replacements to the equipment. Assistance in service methods, contact the factory for authorized service agency or go to our web site www.mfii.com under service for maintenance or repairs.

6.2 DAILY CLEANING

After each period of daily operation (*more frequently as required to maintain cleanliness*) the cooker should be thoroughly cleaned by completing the following steps:

1. Remove the left and right side pan support racks by lifting them up off their mounting brackets.
2. Remove the a-la-carte tray from the floor of the cooking compartment by lifting the front of the tray off the mounting pins and sliding it forward.
3. Wash cooking compartment interior using detergent and water. Rinse and dry thoroughly.
4. Remove upper and lower drip/spill trough screens. Lift the left side of the screen up and swing it out away from the face of the unit until it is free to slide out from under the control panel housing.
5. Wash all removed pieces with a detergent, using a brush and rinse. These pieces can also be sent through a commercial automatic dishwasher. Set these pieces aside for reassembly.
6. Replace the drip/spill trough screens by sliding the right side of the screens under the control panel housing. Then swing the left hand side of the screen in towards the face of the unit until the screen is free to drop down into position.
7. Replace drain screen onto rear wall of cooking compartment by sliding it down onto its mounting tabs.
8. Replace a-la-carte tray by sliding it back until it drops down onto its mounting pins.
9. Replace pan supports into cooking cavity by hanging them on their mounting brackets. Be sure to hang the support with the metal baffling on it on the right side (*steam inlet opening*) side of the cooking cavity.

6.3 PREVENTIVE MAINTENANCE

A good preventive maintenance program begins with the daily cleaning procedure described above. Additional preventive maintenance operations are presented in this section. In establishments which employ full-time maintenance personnel, the task described can be assigned to them. For other installation, tasks requiring mechanical or electrical experience must be performed by an authorized service agent.

CAUTION: UNDER NO CIRCUMSTANCES SHOULD HARDWARE (OR PARTS) BE REPLACED WITH DIFFERENT SIZE OR TYPE OTHER THAN AS SPECIFIED IN THE PARTS LIST. THE HARDWARE USED IN THE COOKER HAS BEEN SELECTED OR DESIGNED SPECIFICALLY FOR ITS APPLICATION AND THE USE OF OTHER HARDWARE MAY DAMAGE THE EQUIPMENT, PRESENT A SAFETY HAZARD AND WILL VOID ANY WARRANTY.

The following sections set forth minimum preventive maintenance procedures which must be completed periodically to assure continued trouble free operation.

6.4 CLEANING THE GENERATOR

The Steam-Tech Plus has an automatic indicator light which tells you when the steam generator needs to be cleaned. When the CLEAN GENERATOR light comes on the generator remains fully functional until it is shut down. This will allow you to continue to use the unit for the remainder of the day until you shut down. The next time the unit is turned on the generator will fill and preheat to 190°F., but it will not create steam. The CLEAN GENERATOR light will remain illuminated. The steam generator must be cleaned before it will create steam again.

6.4.1 CLEANING INSTRUCTIONS

These cleaning instructions can also be found printed on the sticker, on the top of the electrical box inside the unit. In order to perform this procedure, you will need "**TOTAL CONCEPT de-liming solution**" (*Market Forge Part Number 20-0307*) To order this part please contact our factory at (888) 698-3188 or our Parts Department at (888) 259-7076.

1. Leave the POWER switch on and wait for the green READY light.
2. Remove the right pan support rack from inside the cooking compartment to reveal the side wall opening.
CAUTION: THE STEAM GENERATORS AND PIPE FITTINGS REACH 190°F DURING THE PREHEAT CYCLE. USE CAUTION AND WEAR PROTECTIVE HAND GLOVES. DO NOT TRY TO REACH INTO THE OPEN SIDE WALL PORT! THIS OPENING IS DIRECTLY CONNECTED TO THE STEAM GENERATOR.
3. Pour 1/2 gallon of the TOTAL CONCEPT directly into the open side wall port. This will immerse the heater and water level probes in de-liming solution. **CAUTION:** READ DIRECTIONS AND INFORMATION ON THE TOTAL CONCEPT CONTAINER BEFORE USING.
4. Wait 2 hours for the solution to work. (Other de-liming solutions may take much longer)
5. Make sure the cooking compartment door is unlatched and slightly ajar, then press the RINSE AND DRAIN button for the generator being cleaned.

This will start the draining and spray rinsing of the generator. The rinse and drain cycle will run for approximately 3 minutes. At the end of the cycle the generator will automatically refill and warm up. It is not necessary to rinse and drain more than once. The rinsing spray inside the generator will remove all traces of the de-liming solution.

NOTE: When the steam generator is clean the CLEAN GENERATOR light will go off as soon as the green READY light comes on.

CAUTION: IF, AFTER CLEANING THE GENERATOR AND THE CLEAN GENERATOR LIGHT IS STILL ON AFTER WARMING UP (WHEN THE READY LIGHT COMES ON), THERE MAY BE AN ELECTRICAL PROBLEM. SEE SECTION 5.4 AND/OR CONSULT WITH QUALIFIED SERVICE PERSONNEL FOR TEST AND REPAIR.

6. MAINTENANCE

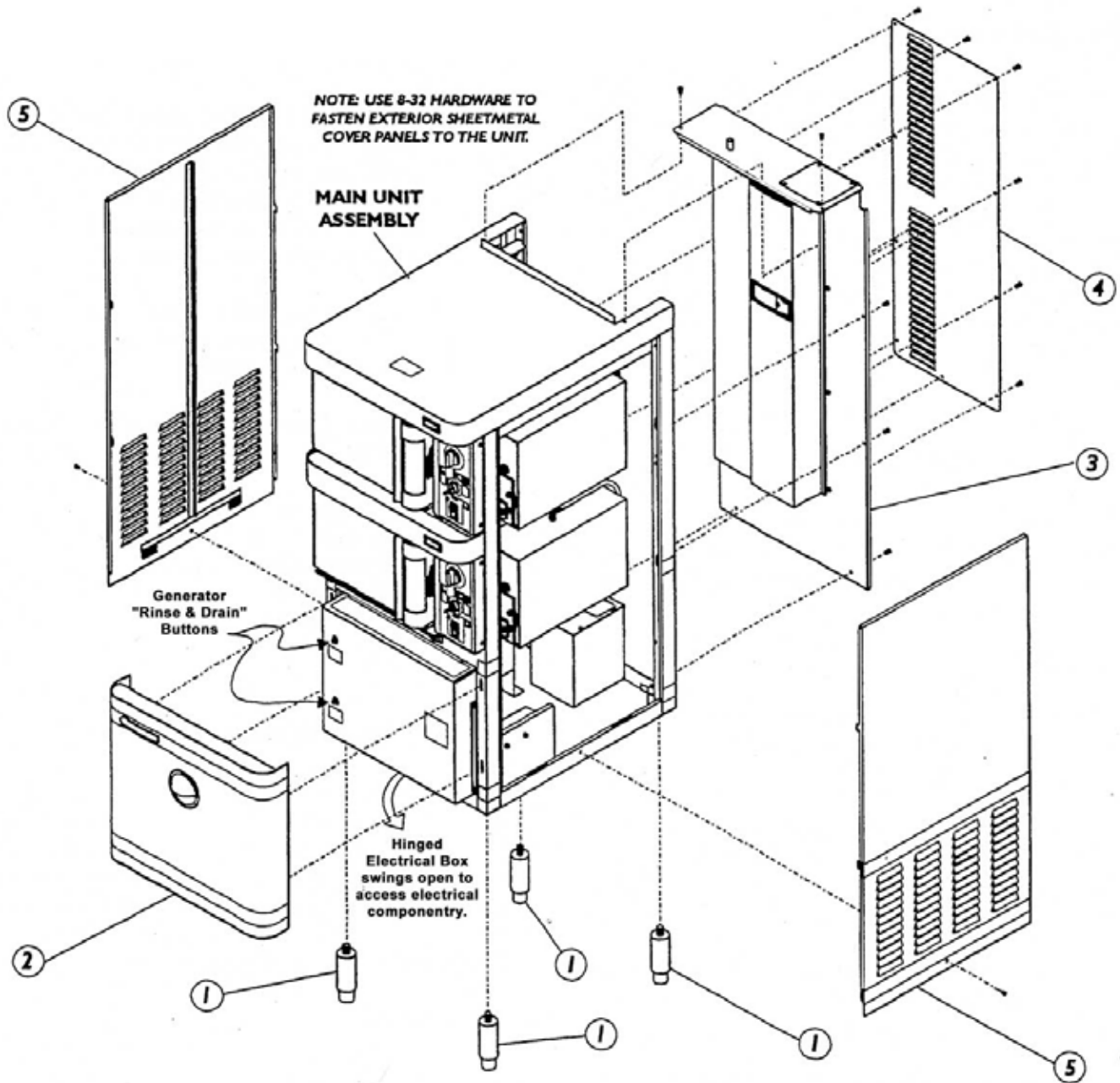

FIGURE 6.1 EXTERIOR STEEL-METAL COVER PANEL AND FASTENERS

ITEM NO.	DESCRIPTION	QTY.	PART NO.
1	LEG, BLACK, ADJUSTABLE	4	E10-0631
2	FRONT COVER PANEL ASSEMBLY	1	E91-5767
3	REAR COVER PANEL ASSEMBLY	1	E91-5789
4	REMOVABLE VENT HATCH	1	E91-5777
5	SIDE COVER PANEL ASSEMBLY	2	E91-5778
FASTENERS 8-32 SLOTTED TRUSS HEAD MACHINE SCREW, 3/8" LONG, STAINLESS STEEL		22	E08-3492

6. MAINTENANCE

6.5 CLEANING THE STEAM VENTILATION DUCTWORK

The Steam-Tech Plus ventilation ductwork system is made up of a series of horizontal and vertical ducts. This series of ductwork must be cleaned periodically in order to maintain cleanliness. Frequency will vary according to use. The recommended procedure for cleaning of the steam ventilation ductwork is contained in this section.

NOTE: In order to perform this procedure, you must gain access to the rear of the unit.

1. Disconnect the 208/240/480 volt power supply.
2. Disconnect the 120v power supply.
3. Slide the unit out away from the wall (*you may need to disconnect the water inlet line*).
4. Remove the 11 screws which hold the louvered vent access hatch onto the rear panel of the unit. (*Refer to Figure 6.1 on page 6.2.*)
5. Using detergent and a damp cloth, wipe clean the inside of both the upper and lower horizontal intake ducts, located just above the cooking compartments. The very front of these ducts may be accessed more easily from the front of the unit.
6. Using detergent and a damp cloth wipe clean the inside of both the vertical intake and exhaust ducts. These ducts are mounted onto the inside of the rear panel of the unit.
CAUTION: WHEN CLEANING THE VERTICAL EXHAUST DUCT BE VERY CAREFUL NOT TO DAMAGE THE BLOWER WHICH IS LOCATED AT THE BOTTOM OF THE DUCT. LOOKING AT THE UNIT FROM THE REAR, THE VERTICAL EXHAUST DUCT IS THE ONE ON THE RIGHT.

7. Using detergent and a damp cloth, wipe clean the inside of the vent access hatch.
8. Reinstall vent access hatch onto the rear of the unit.
9. Using detergent and a damp cloth, wipe clean the inside of the upper and lower steam vent hoods located on the front of the unit, just above each of the cooking compartments.
10. Reconnect 120v power supply.
11. Reconnect 208/240/480 volt power supply.
12. Slide the unit back into place. **NOTE:** You may need to relevel the unit, as described in step 5 of section 2.1.
13. If you have disconnected the water inlet line, reconnect it now.

6.6 ELECTRICAL BOX SERVICE ACCESS

The steam-Tech Plus electrical box is located behind the lower front panel of the unit. Most major electrical components is mounted onto the inside of the electrical box.

CAUTION: BE SURE TO DISCONNECT BOTH POWER SUPPLIES FROM THE UNIT BEFORE SERVICING ANY ELECTRICAL COMPONENTS.

To gain access to the electrical box, the lower cover panel must be removed from the front of the unit. Prior to removing this panel the lower drip/spill trough screen must be removed. Gripping the round handle, slide the panel upwards until it stops and pull it out away from the unit. This will reveal the hinged electrical box. Unscrew the captive screw latch which is located on the left side of the electrical box and swing the electrical box open to access the electrical components for service.

6. MAINTENANCE

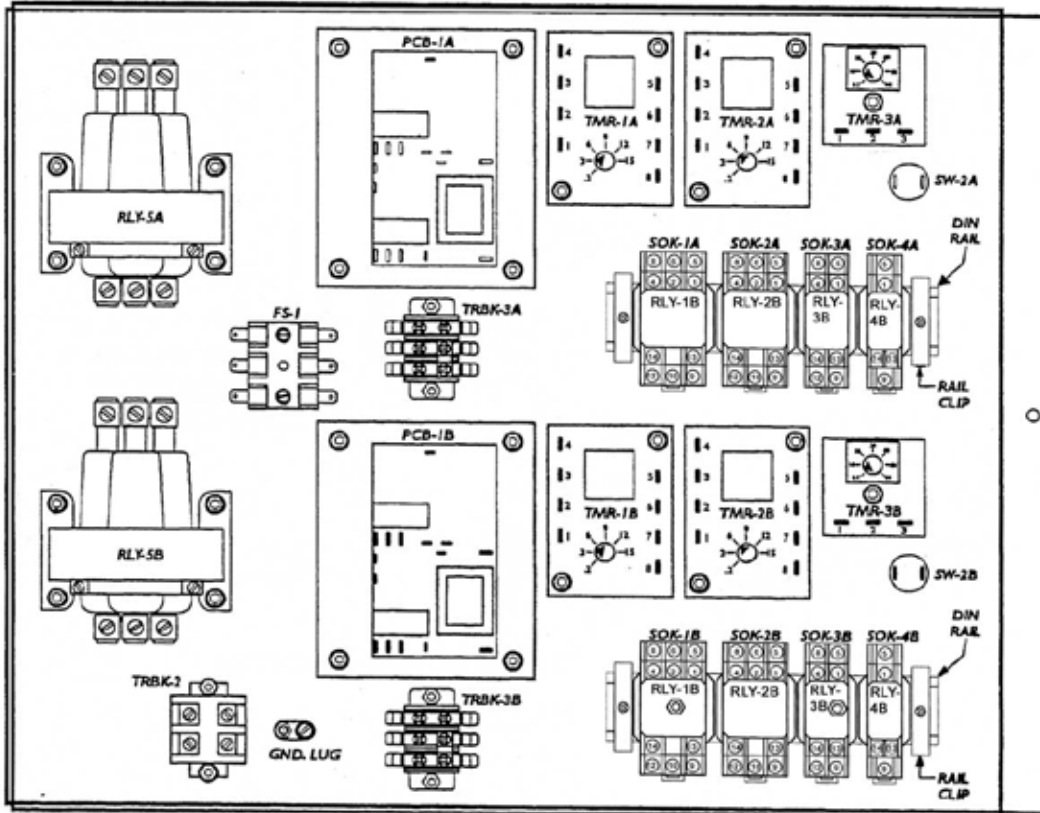
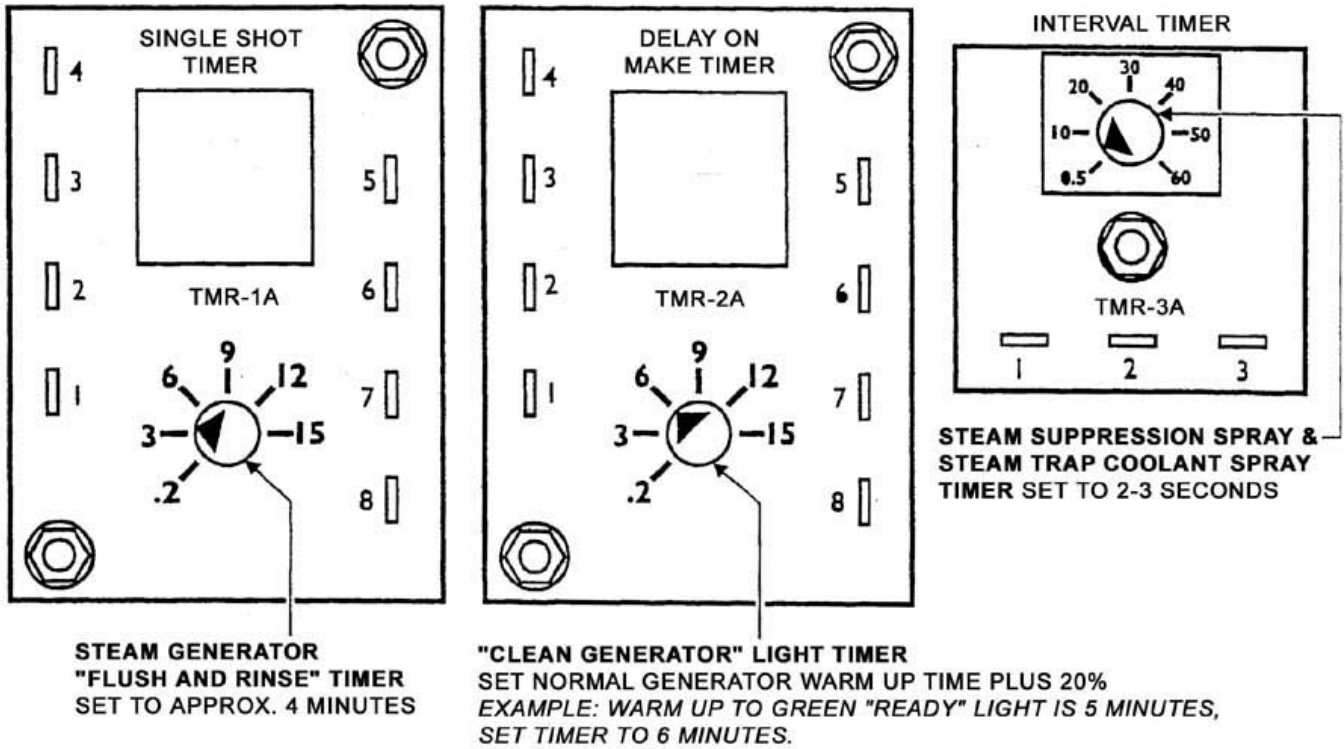

FIGURE 6.2 ELECTRICAL PANEL ASSEMBLY

ITEM NO.	DESCRIPTION	QTY.	PART NO.
DINRAIL	RELAY MOUNTING RAIL	2	08-6515
FS-1	FUSE LOCK	1	08-6520
GND. LUG	GROUNDING JUG	1	10-5220
PCB-1	WATER LEVEL CONTROL	2	08-6328
RAIL CLIP	DIN RAIN RETAINER CLIPS	4	08-6516
RYL-1	RELAY 3PDT	2	08-6509
RYL-2	RELAY DPDT MAGNETIC LATCH	2	08-6510
RYL-3	RELAY DPDT	2	08-6508
RYL-4	RELAY SPDT	2	10-9174
RYL-5	MERCURY SWITCH 1 PHASE	2	08-6534
RYL-5	MERCURY SWITCH 3 PHASE	2	08-6513
SOK-1&2	RELAY SOCKET	4	08-6512
SOK-3	RELAY SOCKET	2	08-6511
SOK-4	RELAY SOCKET	2	10-9175
SOK-2	PUSHBOTTON	2	08-6517
TMR-1	TIMER SINGLE SHOT	2	08-6504
TMR-2	TIMER DELAY ON MAKE	2	08-6505
TMR-3	TIMER INTERNAL	2	08-6506
TRBK-2	TERMINAL BLOCK	1	08-6519
TRBK-3	TERMINAL BLOCK	2	08-6518

6. MAINTENANCE



TIMER SETTINGS AND TERMINAL NUMBERS & LOCATIONS

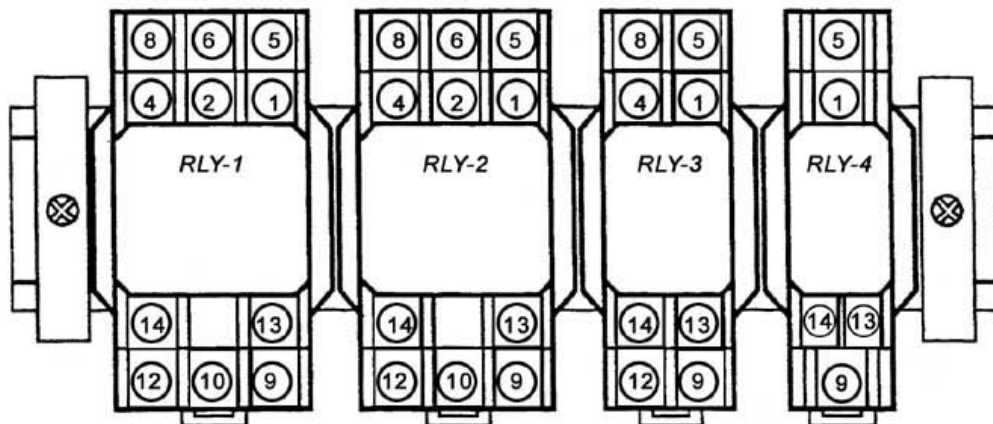

RELAY TERMINAL CONTACT NUMBERS & LOCATIONS

FIGURE 6.3

6. MAINTENANCE

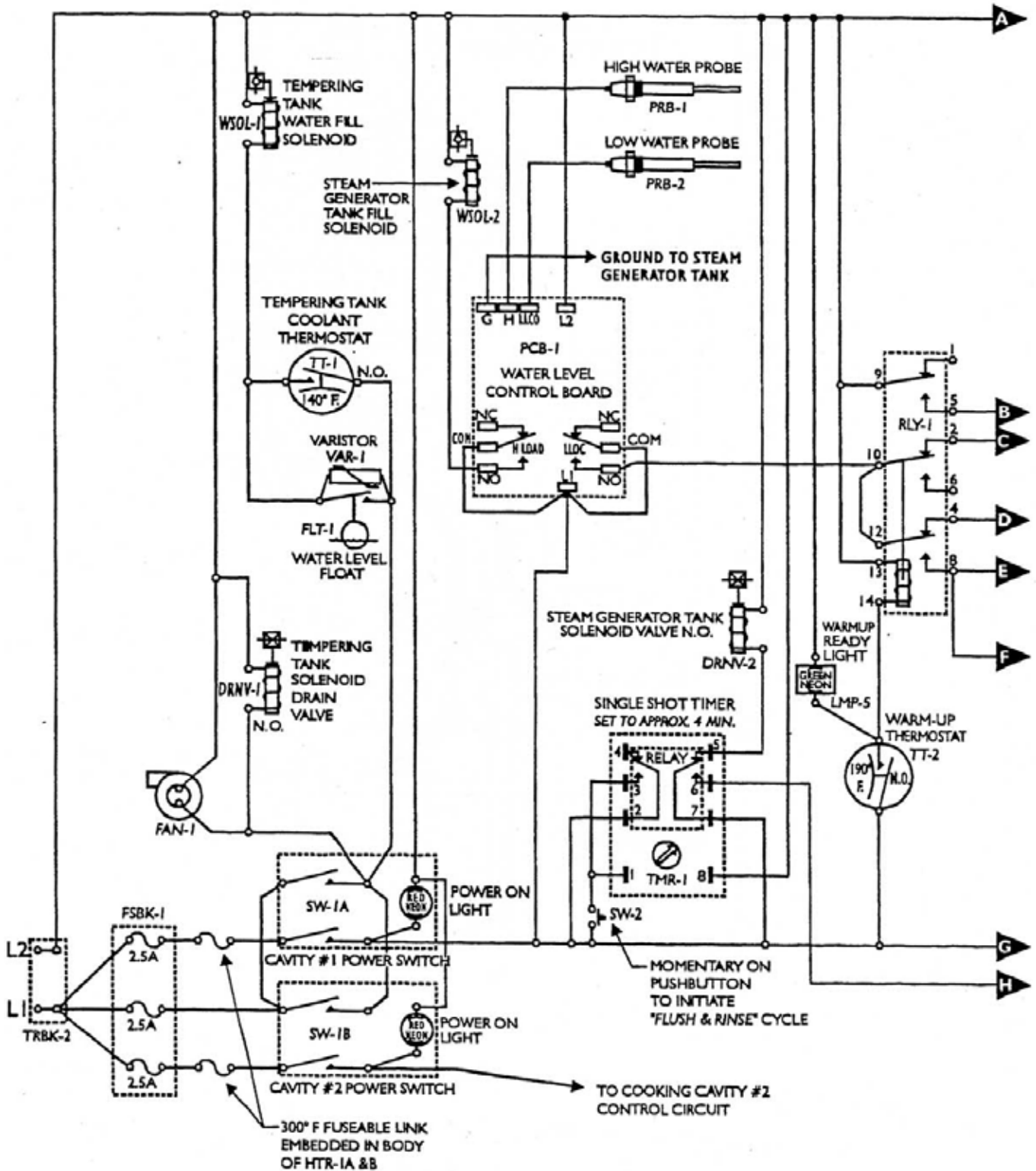

FIGURE 6.5 SINGLE COMPARTMENT SYSTEM WIRING DIAGRAM

6. MAINTENANCE

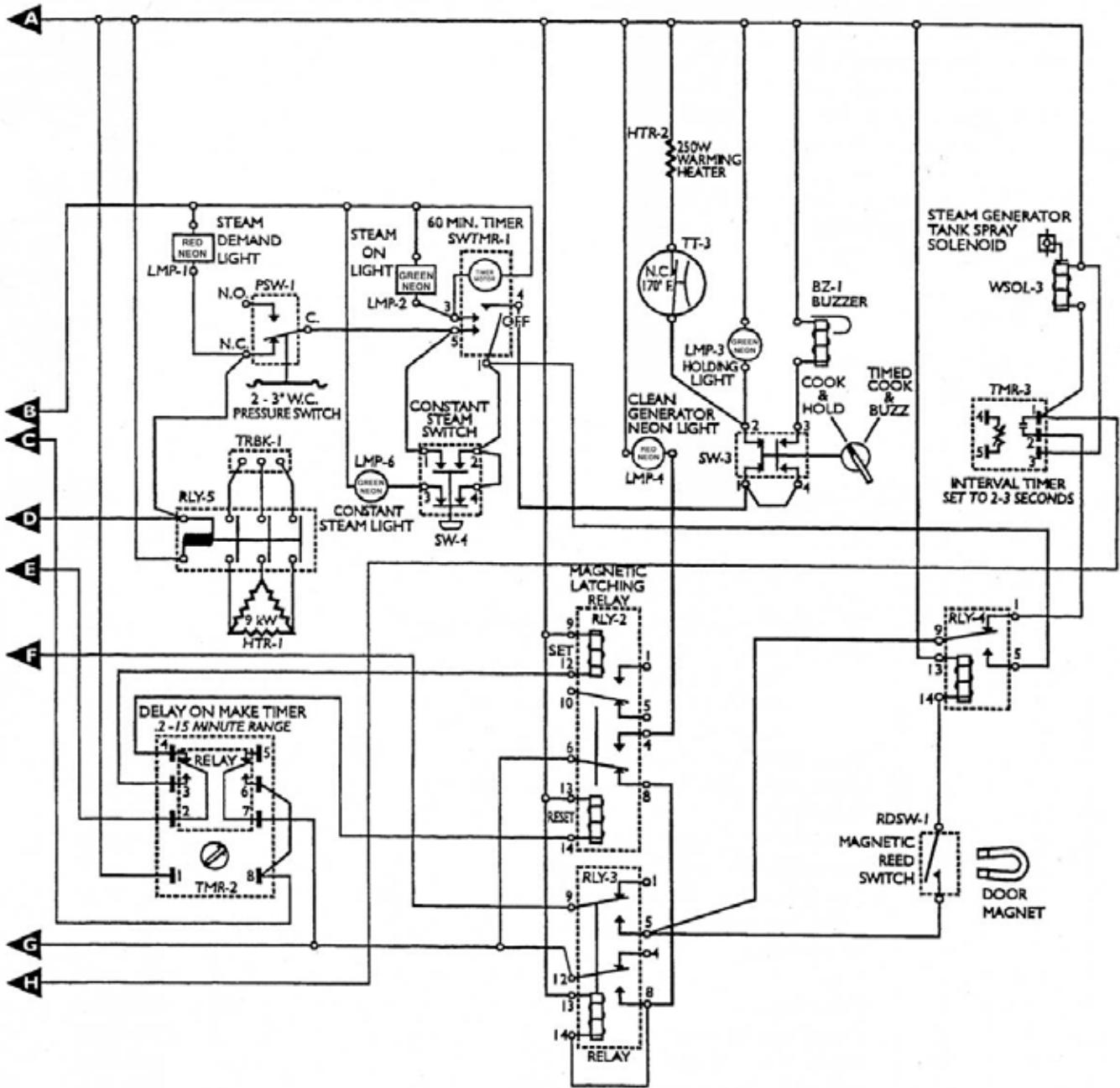

FIGURE 6.6 SINGLE COMPARTMENT SYSTEM WIRING DIAGRAM

6. MAINTENANCE

6.7 CONTROL PANEL ELECTRICAL SERVICE ACCESS

The control panel assembly is mounted onto the front of the unit. It houses all of the controls and indicators which are used to operate the cooker. In order to service any of the control panel electrical components the control panel assembly must be removed from the front of the unit.

CAUTION: BE SURE TO DISCONNECT BOTH POWER SUPPLIES FROM THE UNIT BEFORE SERVICING ANY ELECTRICAL COMPONENTS.

1. Remove the 4 screws that fasten the control panel assembly onto the front of the unit.
2. Gently move the control panel assembly out away from the unit. **NOTE:** Only move the control panel assembly out as far as is necessary to access the rear of the assembly. PULLING OUT THE CONTROL PANEL TOO FAR CAN CAUSE DAMAGE BY PUTTING UNNECESSARY STRAIN ON WIRES AND CONNECTIONS.
3. Separate the control panel housing and indicator light mounting brackets by removing the 4 nuts which hold them together. Be careful not to lose the 1/4-20 nuts which are used as spacers (1-per stud). This will allow total access to all controls and indicators for service, repair, or replacement. See Figure 6.3 on page 6.1.

6.8 DOOR ADJUSTMENT

The cooking compartment door alignment, door tension and latch tension are pre-adjusted at the factory during assembly.

During normal usage, these should not need any attention.

Note that when the cooking compartment doors are reversed, as described in section 2.3, the doors will need to be aligned and the door latch tension will need to be adjusted (*the door handle will not need adjustment when the door is reversed*).

6.8.1 DOOR ALIGNMENT

The cooking compartment doors are pre-aligned at the factory during assembly, and should not need adjusting unless they are reversed. Should the doors need realignment, the procedure is as follows:

1. Open the cooking compartment door.
2. Loosen all 4 bolts (2-per hinge) which mount the upper and lower hinge brackets to the face of the unit using a 5/16" wrench. DO NOT REMOVE THE BOLTS.
3. Begin to retighten the 4 bolts so that they are snug against the face of the unit. DO NOT COMPLETELY TIGHTEN THE BOLTS.
4. Slowly ease the cooking compartment door closed until it is latched.
5. The cooking compartment door can now be raised, lowered, and/or rotates into position by bumping it with the palm of your hand or a small rubber mallet.
6. First check the alignment at the front of the door by making sure that the striker in the door is centered with the latch mechanism on the front of the door.

ITEM NO.	DESCRIPTION	FIGURE 6.7 CONTROL PANEL ASSEMBLY	QTY.	PART NO.
1	BUZZER		1	E10-6682
2	"CLEAN GENERATOR" INDICATOR LIGHT - ROUND NEON RED		1	E08-6530
3	"CONSTANT STEAM" BUTTON		1	E08-6526
4	"CONSTANT STEAM" INDICATOR LIGHT - ROUND NEON GREEN		1	E08-6529
5	CONTROL PANEL HOUSING ASSEMBLY		1	E91-5743
6	CONTROL PANEL LIGHT MOUNTING BRACKET		1	E91-5688
7	"HOLD" INDICATOR LIGHT - ROUND NEON AMBER		1	E08-6531
8	"MODE SELECT" SWITCH ASSEMBLY		1	E08-6525
9	"POWER ON" INDICATOR LIGHT		1	E08-6523
10	"POWER ON" INDICATOR LIGHT TINNERMAN RETAINER CLIP		1	E08-6523
11	POWER SWITCH		1	E08-6524
12	"READY" INDICATOR LIGHT - RECTANGULAR NEON GREEN		1	E08-6527
13	ROUND INDICATOR LIGHT RETAINER CLIP		3	E08-6527
14	"STEAM DEMAND" INDICATOR LIGHT - RECTANGULAR NEON RED		1	E08-6528
15	"STEAM ON" INDICATOR LIGHT - RECTANGULAR NEON GREEN		1	E08-6527
16	TERMINAL BLOCK		1	E08-6518
17	TIMER		1	E10-6291
18	TIMER KNOB		1	E08-3826
19	TIMER MOUNTING NUT		1	E10-6291
20	1/4-20 HEX NUT - ZINC PLATED		4	E08-3844
21	6-32 NUT WITH NYLON INSERT - ZINC PLATED		2	E08-3838
22	6-32 SLOTTED PAN HEAD MACHINE SCREW - ZINC PLATED 1/2" LONG		2	E08-3438
23	8-32 NUT WITH NYLON INSERT - ZINC PLATED		4	E08-3839

6. MAINTENANCE

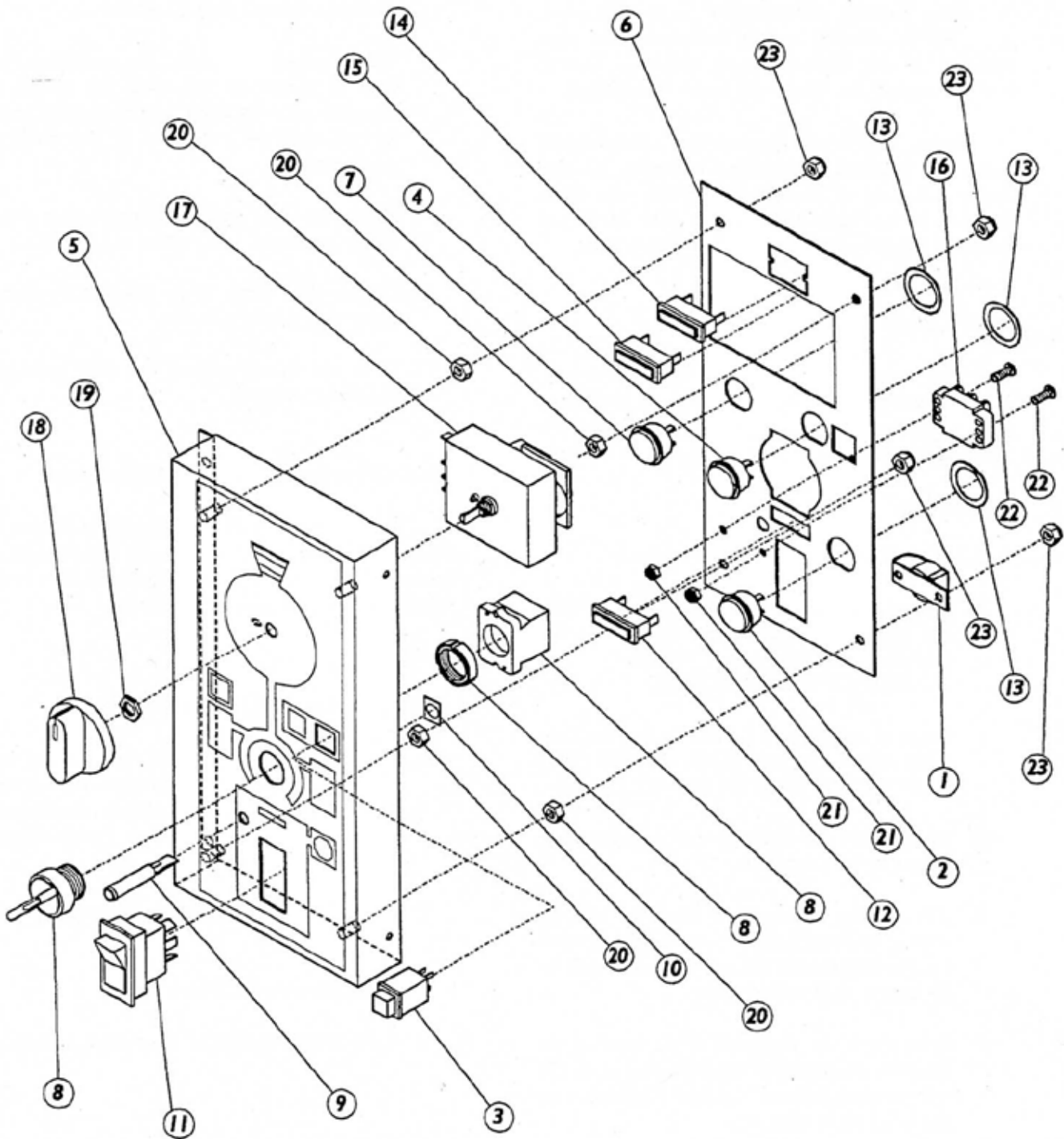

FIGURE 6.7 CONTROL PANEL ASSEMBLY

7. Square the door to the unit by raising or lowering the hinge side of the door keeping the latch centered with the striker.
8. Visually inspect the door. Be sure that the door is square to the unit the striker is centered with the latch and the gasket is in contact with the entire lip of the cooking compartment.
9. Gently open the cooking compartment door taking care not to move it out of position.
10. Tighten all 4 door hinge bracket mounting bolts, using a

5/16" wrench.

11. Close and visually inspect the door again as described in step 8.

6.8.2 DOOR LATCH TENSION ADJUSTMENT

The cooking compartment door latch tension is preset at the factory and should not need adjusting unless the doors are reversed. Should the latch need adjusting the procedure is as follows:

1. Open the cooking compartment door.
2. If latch is mounted on the right side of the cooking compart-

6. MAINTENANCE

ment, remove the corresponding control panel. If latch is mounted on the left side, remove left side panel.

3. Tighten both nuts down until the springs are fully compressed.
4. Back each nut off 1/2 turn.
5. Remount the control panel or left side panel.

6.8.3 DOOR HANDLE TENSION ADJUSTMENT

The cooking compartment door handle tension is preset at the factory and should not need adjusting unless the doors are reversed. Should the door handle need adjusting the procedure is as follows:

1. Open the cooking compartment door.

2. Remove the 6 screws, 3 from top edge and 3 from bottom edge of door.
3. Remove the door gasket, door gasket mounting plate and door insert from the door. Do not disassemble these three components, remove them as an assembly.
4. Tighten both nuts down until the springs are fully compressed.
5. Back each nut off 5 turns.
6. Replace the door gasket, mounting plate and insert assembly.
7. Remount the large side panel.

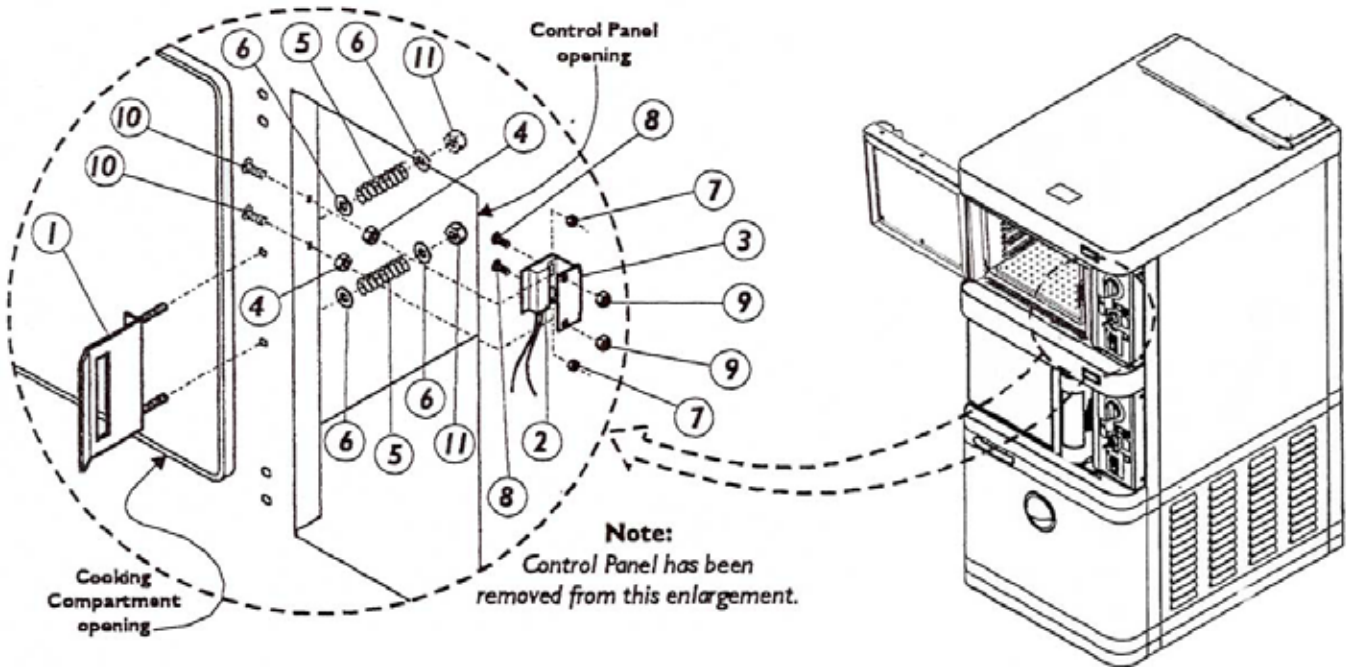

FIGURE 6.8 DOOR LATCH AND MAGNET SENSOR ASSEMBLY

ITEM NO.	FIGURE 6.8 DOOR LATCH AND MAGNET SENSOR ASSEMBLY DESCRIPTION	QTY.	PART NO.
1	DOOR LATCH	1	E91-5746
2	DOOR SENSOR (MAGNETIC REED SWITCH)	1	E08-6308
3	DOOR SENSOR MOUNTING BRACKET	1	E91-5697
4	DOOR SENSOR SPACER (6-32 HEX. NUT, ZINC PLATED)	2	E10-2331
5	SPRING	2	E08-4600
6	WASHER, NYLON	4	E10-0100
7	4-40 HEX. NUT, WITH NYLON INSERT, ZINC PLATED	2	E08-3845
8	4-40 SLOTTED PAN HEAD MACHINE SCREW, ZINC PLATED, 3/8" LONG	2	E08-3496
9	6-32 HEX. NUT, WITH NYLON INSERT, ZINC PLATED	2	E08-3838
10	6-32 SLOTTED PAN HEAD MACHINE SCREW, ZINC PLATED, 1/2" LONG	2	E08-3484
11	10-32 NUT, WITH NYLON INSERT, ZINC PLATED	2	E08-3841

6. MAINTENANCE

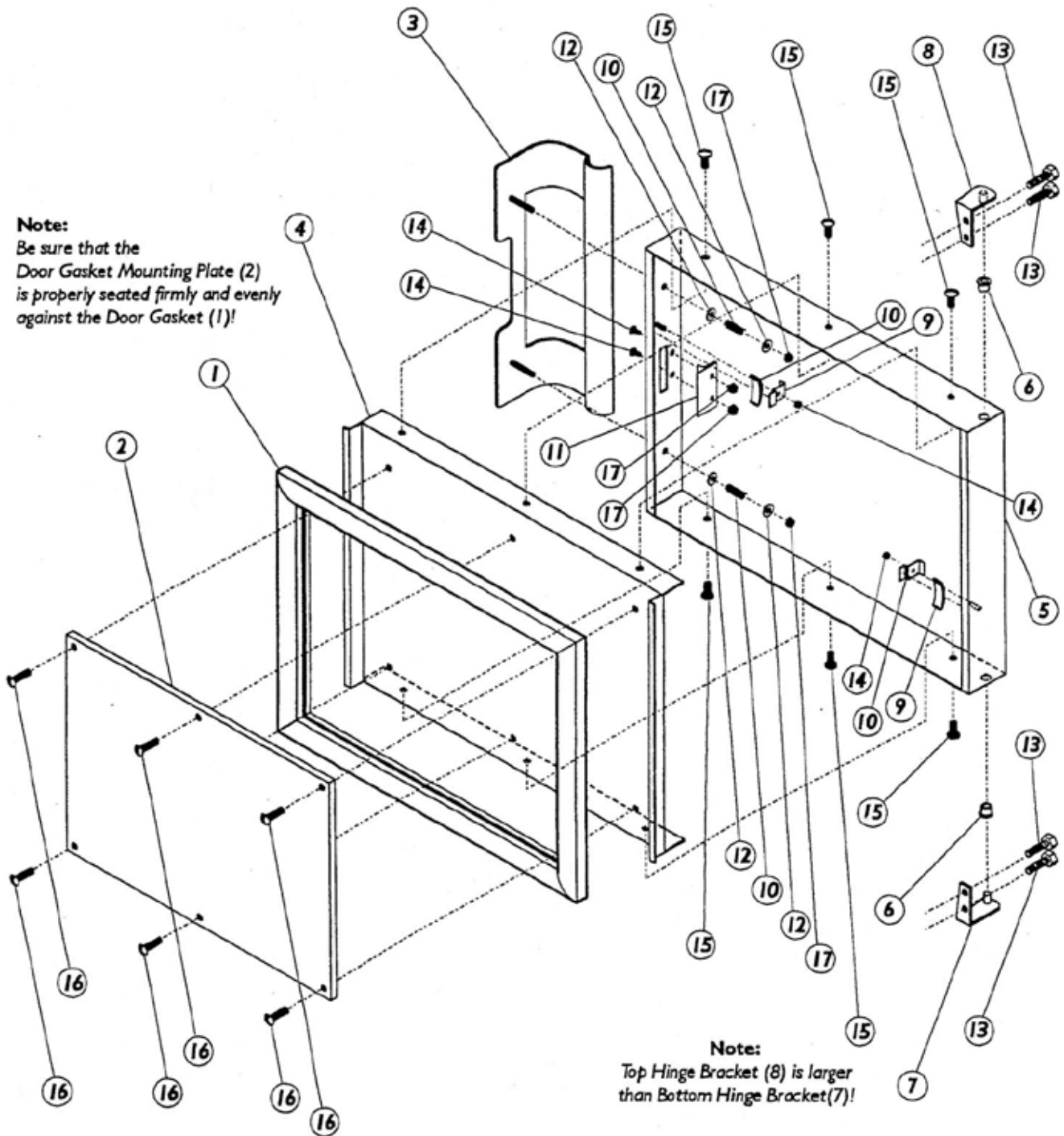

FIGURE 6.9 COOKING COMPARTMENT DOOR ASSEMBLY

6. MAINTENANCE

ITEM NO.	FIGURE 6.9 COOKING COMPARTMENT DOOR ASSEMBLY DESCRIPTION	QTY.	PART NO.
1	DOOR GASKET	1	E91-5286
2	DOOR GASKET MOUNTING PLATE	1	E91-5731
3	DOOR HANDLE	1	E91-5745
4	DOOR INSERT	1	E91-5766
5	DOOR SHELL	1	E91-5729
6	HINGE BEARING, NYLON	2	E08-2702
7	HINGE BRACKET, BOTTOM (SMALLER)	1	E91-5436
8	HINGE BRACKET, TOP (LARGER)	1	E91-5437
9	MAGNET	2	E08-5027
10	MAGNET RETAINER BRACKET	2	E91-5901
11	SPRING	2	E08-4600
12	STRIKER, CAST	1	E09-1608
13	WASHER, NYLON	4	E10-0100
14	6-32 NUT WITH NYLON INSERT, ZINC PLATED	2	E08-3838
15	10-32 HEX HEAD MACHINE SCREW, 7/8" LONG, STAINLESS STEEL	4	E08-3488
16	10-32 PHILLIPS FLAT MACHINE SCREW, 1/2" LONG, STAINLESS STEEL	2	E08-3486
17	10-32 SLOTTED TRUSS HEAD MACHINE SCREW, 1/2" LONG, STAINLESS STEEL	6	E10-1764
18	10-32 SLOTTED TRUSS HEAD MACHINE SCREW, 3/4" LONG, STAINLESS STEEL	6	E10-1765
19	10-32 NUT WITH NYLON INSERT, ZINC PLATED	4	E08-3841

6.9 DOOR GASKET REPLACEMENT

The cooking compartment door gaskets are made of a silicone type rubber material, which is very durable, but is subject to wear during normal daily operation. This gasket may start to leak which will cause the steamer to malfunction. Should the gasket begin to leak, it should be replaced as follows:

1. Open the cooking compartment door.
2. Remove the 6 screws from the door gasket mounting plate on the inside of the door.

3. Remove the door gasket mounting plate and the door gasket.
4. Install new door gasket (*Market Forge Part Number 91-5286*) into the door.
5. Refasten the door gasket mounting plate to the inside of the door using the 6 screws.

NOTE: Remember that the lip on the door gasket mounting plate must fit into the channel on the inside edge of the gasket for a proper seal.

ITEM NO.	FIGURE 6.10 SINGLE ELECTRIC POWERED STEAM GENERATOR ASSEMBLY DESCRIPTION	QTY.	PART NO.
1	ELECTRIC SEAM GENERATOR TANK	1	E91-5727
2	ELBOW, 1/8" mNPT TO 1/4" HOSE BARB, BRASS	1	E08-5063
3	ELBOW, 1/8" FNPT TO 1/4" HOSE BARB, BRASS	1	E08-5004
4	GASKET, OBRROUND	2	E91-5717
5	HEATER: 208V	1	E08-6485
	HEATER: 240V		E08-6486
	HEATER: 480V		E08-6487
6	HEATER GASKET	1	E91-8660
7	HEATER MOUNTING PLATE	1	E91-5721
8	SPRAY NOZZLE	1	E08-5017
9	THERMAL FUSIBLE LINK	1	E91-6693
10	THERMOSTAT, N.O., 193°F	1	E10-8105
11	WATER LEVEL PROBE	2	E08-6338
12	1/4-20 NUT WITH NYLON INSERT, STAINLESS STEEL	14	E08-3850
13	1/4" WASHER, STAINLESS STEEL	14	E08-4011

6. MAINTENANCE

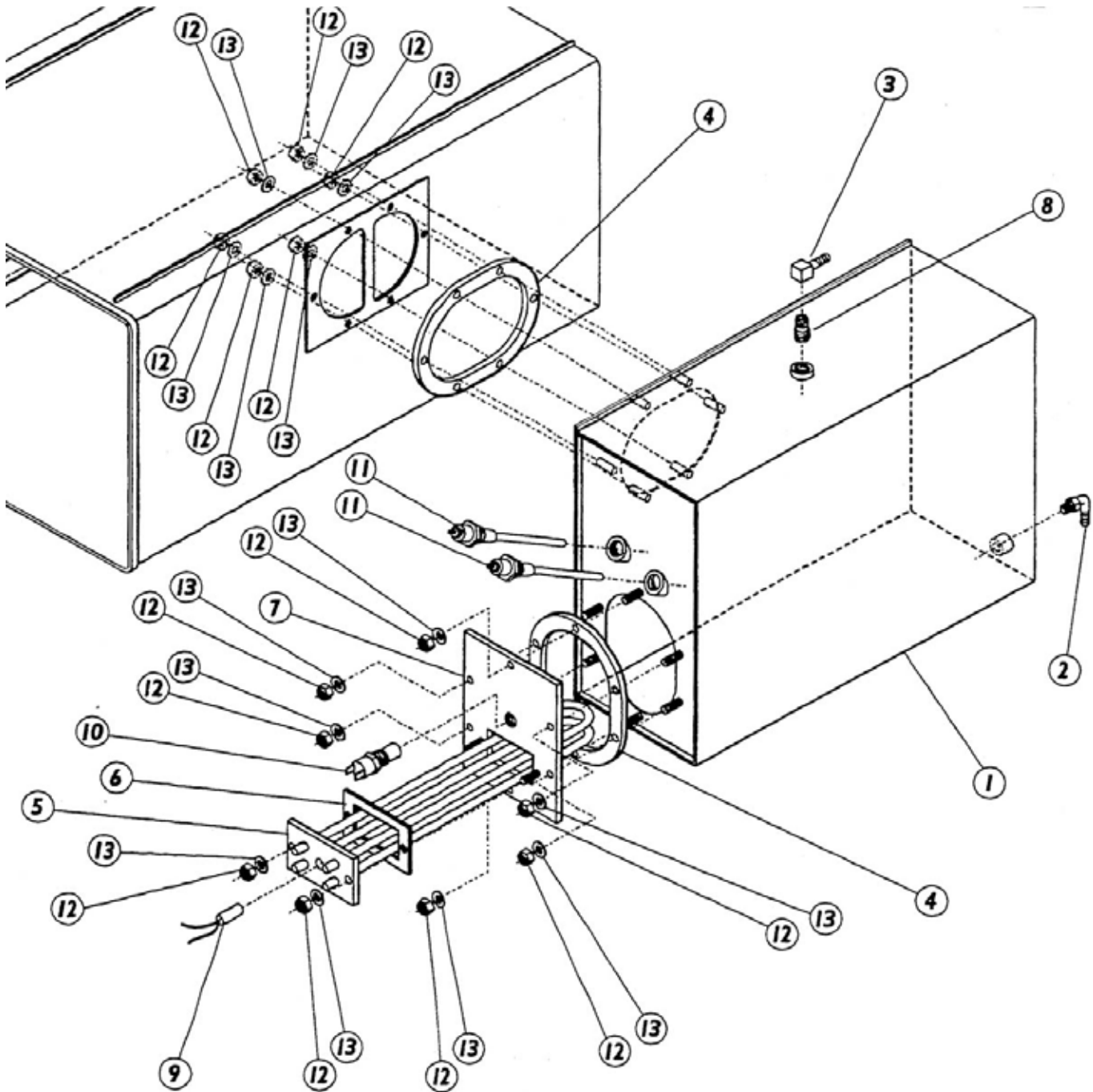

FIGURE 6.10 SINGLE ELECTRIC POWERED STEAM GENERATOR ASSEMBLY

6.10 SOLENOID FILL VALVE STRAINER SCREEN CLEANING

The solenoid fill valves contain a built in strainer screen inside the valve body. This screen must be removed and cleaned periodically (depending on usage and water quality) to remove any debris or line build-up which will accumulate during normal operation. The procedure is as follows:

1. Remove the left large side panel by removing the screw from the center of the bottom edge of the panel. Gripping one of the louvers, slide the panel upwards until the bottom edge of the panel is free to swing away from the unit. Slide the panel down until its top edge is clear of the top cap of the unit.
2. Unscrew screen plug from valve and remove screen.
3. Clean screen and reassemble screen and screen plug into valve body.
4. Replace large side panel by placing the panel against the side of the unit. Be sure that the top edge of the side panel slides under the top cap of the unit. Slide the panel upwards until it stops. Then while pushing the panel towards the unit, slide it down into position. Replace screw.

6. MAINTENANCE

ITEM NO.	DESCRIPTION	FIGURE 6.11 BLOWER BOX ASSEMBLY	QTY.	PART NO.
1	BLOWER		1	E08-7501
2	BLOWER BOX		1	E91-5737
3	BLOWER MOUNTING FLANGE		1	E08-7501
4	BLOWER MOUNTING PLATE		1	E91-5738
5	8-32 HEX NUT, STAINLESS STEEL, WITH NYLON INSERT		3	E10-2396
6	#8 FLAT WASHER, STAINLESS STEEL		3	E10-2408
7	10-32 SLOTTED TRUSS HEAD MACHINE SCREW, STAINLESS STEEL, 1/2" LONG		4	E10-1764

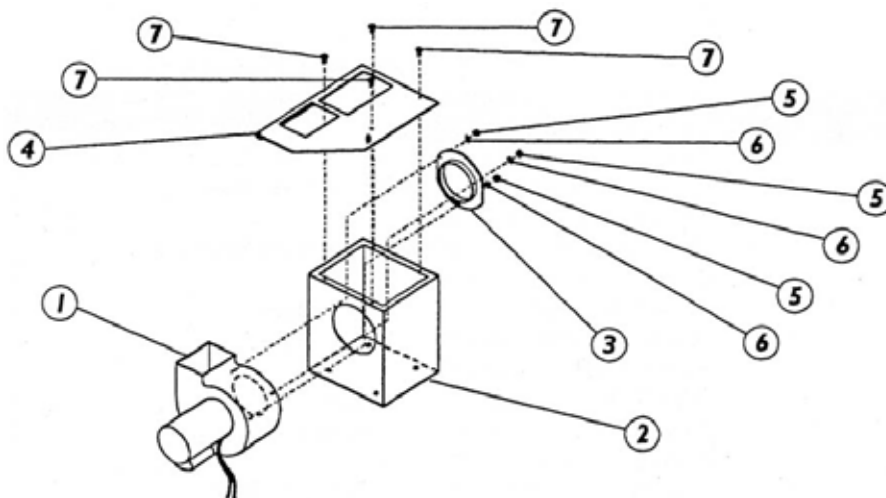

FIGURE 6.11 BLOWER BOX ASSEMBLY

ITEM NO.	DESCRIPTION	FIGURE 6.12 TEMPERING TANK ASSEMBLY	QTY.	PART NO.
1	ADAPTER FITTING, 1/2" mNPT TO 3/4" HOSE BARB, BRASS		3	E08-5029
2	BRANCH TEE, 1/8" mNPT TO 1/4" HOSE BARB, BRASS		4	E08-5009
3	CROSS FITTING, 1/2" NPT, BRASS		2	E08-5011
4	DRAIN VALVE, N.O. (NOTE ORIENTATION WHEN INSTALLING)		3	E08-5021
5	ELBOW UNION, 1/2" NPT, BRASS		1	E09-4844
6	ELBOW, 1/4" mNPT TO 1/4" HOSE BARB, BRASS		5	E08-5005
7	ELBOW, 1/8" mNPT TO 1/4" HOSE BARB, BRASS		1	E08-5063
8	FLEXIBLE DRAIN TUBING, 3/4" I.D., 2.5" LONG		1	E08-5013
9	FLEXIBLE DRAIN TUBING, 3/4" I.D., 4" LONG		1	E08-5013
10	FLOAT SWITCH, N.C. (NOTE ORIENTATION WHEN INSTALLING)		1	E08-5023
11	HOSE CLAMPS FOR 1" O.D. TUBING		6	E08-5014
12	PIPE STUD, 1/2" mNPT TO 1/8" fNPT, BRASS		2	E08-5008
13	REDUCER, 1/2" mNPT, THREADED ONE END, BRASS		2	E08-5007
14	SPRAY NOZZLE, SOLID JET, BRASS		2	E08-5010
15	STEAM TRAP VALVE		2	E08-5012
16	3/4" BEAD x 1/2" MALE NPT, 90° ELBOW, BRASS		3	E08-5029
17	TEMPERING TANK WELDMENT		1	E91-7552
18	THERMOSTAT, N.O., 130°F		1	E08-6514
19	WATER INLET VALVE, N.C. (NOTE ORIENTATION WHEN INSTALLING)		5	E08-4821
20	WATER SUPPLY MANIFOLD		1	E91-5676
21	10-32 NYLOC NUT, ZINC PLATED		3	E08-3841
22	#10 WASHER, ZINC PLATED		3	E08-4010

6. MAINTENANCE

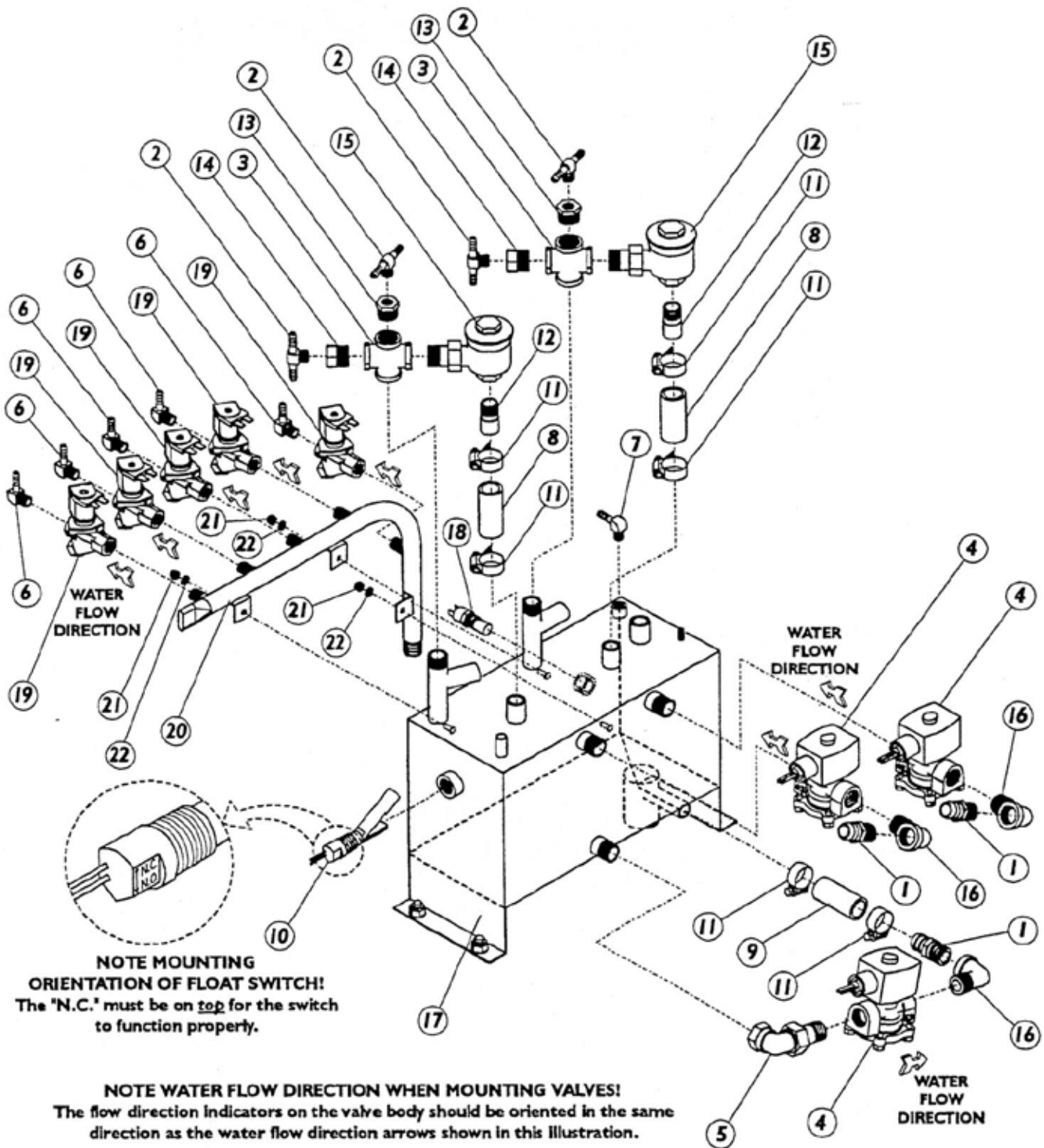

FIGURE 6.12 TEMPERING TANK ASSEMBLY

6. MAINTENANCE

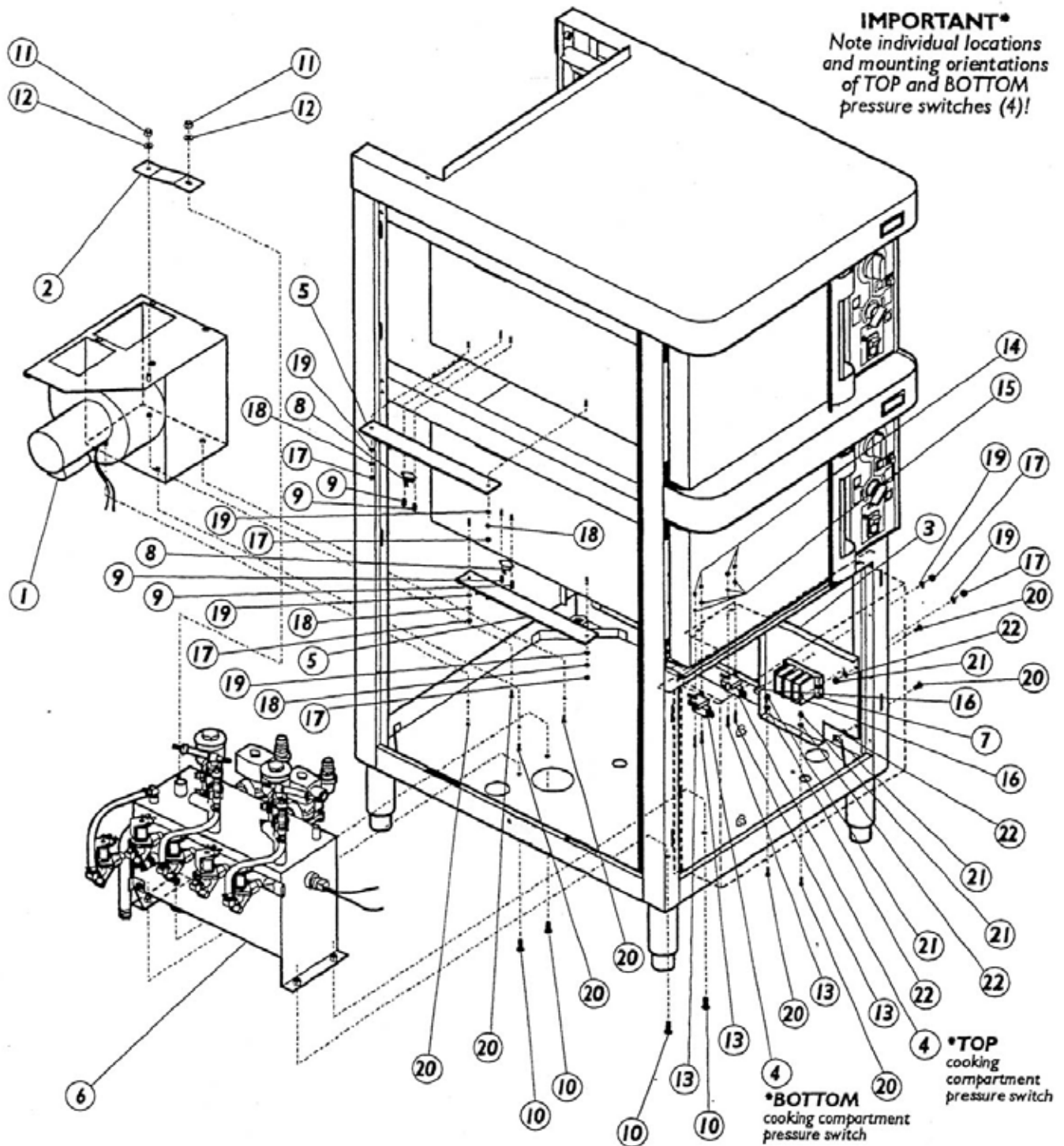

FIGURE 6.13 CHASSIS ASSEMBLY

6. MAINTENANCE

ITEM NO.	DESCRIPTION	FIGURE 6.13 CHASSIS ASSEMBLY	QTY.	PART NO.
1	BLOWER BOX ASSEMBLY		1	SEE FIG 6.12
2	BLOWER BOX SUPPORT BRACKET		1	E91-5739
3	ELECTRIC POWER BRACKET		1	E91-5740
4	PRESSURE SWITCH*		2	E08-6502
5	STRIP HEATER		2	E08-3503
6	TEMPERING TANK ASSEMBLY		1	SEE FIG 6.11
7	TERMINAL BLOCK, PART 1 (QUANTITY 2)		1	E10-5503
	TERMINAL BLOCK, PART 2 (QUANTITY 4)			E10-5070
8	THERMOSTAT, SURFACE MOUNT, N.O., CLOSE AT 170°F		2	E09-6428
9	THREADED STAND-OFF, 6-332 HEX, 1/2" LONG, ZINC PLATED		4	E08-3498
10	1/4-20 HEX HEAD MACHINE SCREW, 7/8" LONG, ZINC PLATED		4	E08-3491
11	1/4-20 NYLOC HEX NUT, ZINC PLATED		2	E08-3842
12	1/4" FLAT WASHER, ZINC PLATED		2	E08-4012
13	4-40 SLOTTED PAN HEAD MACHINE SCREW, 5/8" LONG, ZINC PLATED		4	E08-3497
14	4-40 NYLOC HEX NUT, ZINC PLATED		4	E08-3845
15	#4 FLAT WASHER, ZINC PLATED		4	E10-2524
16	8-32 SLOTTED PAN HEAD MACHINE SCREW, 5/8" LONG, ZINC PLATED		2	E10-1747
17	8-32 NYLOC HEX NUT, ZINC PLATED		6	E08-3840
18	#8 FLAT WASHER, ZINC PLATED E08-4008		6	E08-4009
19	#8 FLAT WASHER, ZINC PLATED		6	E08-4008
20	10-32 SLOTTED PAN HEAD MACHINE SCREW, 1/2" LONG, ZINC PLATED		8	E08-3485
21	10-32 NYLOC HEX NUT, ZINC PLATED		4	E08-3841
22	#8 FLAT WASHER, ZINC PLATED		4	E08-4008

***IMPORTANT:** NOTE THE INDIVIDUAL LOCATIONS OF EACH PRESSURE SWITCH! (SEE FIG. 6.13 ON PAGE 6.17)

- The pressure switch that controls the **BOTTOM** cooking compartment system is on the **LEFT**, as viewed from the front of the unit.
- The pressure switch that controls the **TOP** cooking compartment system is on the **RIGHT**, as viewed from the front of the unit.

6. MAINTENANCE

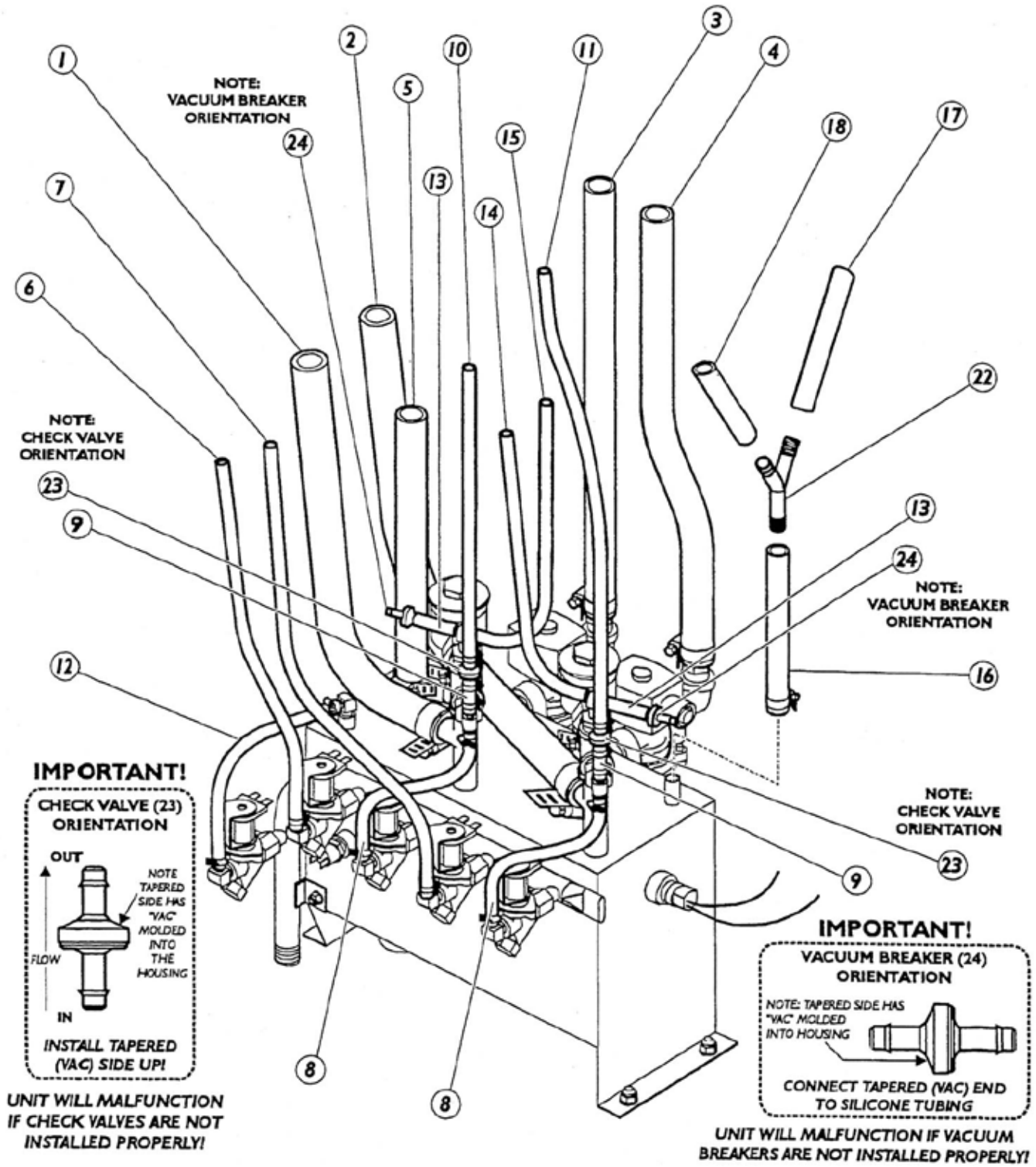

FIGURE 6.14 TUBING ROUTING

6. MAINTENANCE

ITEM NO.	DESCRIPTION	LENGTH	QTY.	PART NO.
FIGURE 6.14 TUBING ROUTING				
NORPRENE TUBING, BLACK, 3/4" I.D., 1/8" WALL (CLAMP ALL CONNECTIONS)				
1	TOP COOKING COMPARTMENT DRAIN	35"	1	E08-5013
2	BOTTOM COOKING COMPARTMENT DRAIN	25.5"	1	E08-5013
3	TOP GENERATOR DRAIN	35"	1	E08-5013
4	BOTTOM GENERATOR DRAIN	21"	1	E08-5013
5	VENT CONNECTION	48"	1	E08-5013
TYGON TUBING, CLEAR, BRAIDED REINFORCED, FOOD GRADE, 1/4" I.D. (CLAMP ALL CONNECTIONS)				
6	TOP GENERATOR FILL	35"	1	E08-5006
7	BOTTOM GENERATOR FILL	21"	1	E08-5006
8	SOLENOID VALVE TO "T" FITTING (FOR SPRAY NOZZLE)	7"	2	E08-5006
9	"T" FITTING TO CHECK VALVE (FOR GENERATOR SPRAY NOZZLE)	1.5"	2	E08-5006
10	TOP GENERATOR CHECK VALVE TO TOP GENERATOR SPRAY NOZZLE	60"	1	E08-5006
11	BOTTOM GENERATOR CHECK VALVE TO BOTTOM GENERATOR SPRAY NOZZLE	50.2"	1	E08-5006
12	TEMPERING TANK FILL SOLENOID VALVE TO TEMPERING TANK	8.5"	1	E08-5006
SILICONE TUBING, CLEAR, 3/16" I.D., 0.06 WALL (CLAMP ONLY AT PRESSURE SWITCH CONNECTIONS)				
13	"T" FITTING TO VACUUM BREAK	1.5"	2	E08-5019
14	"T" FITTING TO BOTTOM COMPARTMENT (LEFT) PRESSURE SWITCH*	6.5"	1	E08-5019
15	"T" FITTING TO TOP COMPARTMENT (RIGHT) PRESSURE SWITCH*	9"	1	E08-5019
PVC TUBING, CLEAR, 1/2" I.D., 1/8" WALL (CLAMP ALL CONNECTIONS, EXCEPT AT "Y" FITTING)				
16	TEMPERING TANK TO "Y" FITTING	5"	1	E08-5024
17	"Y" FITTING TO TOP DRIP TROUGH	29"	1	E08-5024
18	"Y" FITTING TO BOTTOM DRIP TROUGH	15"	1	E08-5024
CLAMPS				
19	1" HOSE CLAMPS, NORPRENE AND PVC CONNECTIONS, AS STATED ABOVE		13	E08-5014
20	1/2" HOSE CLAMPS, ALL BRAIDED TYGON CONNECTIONS		18	E08-1206
21	PLASTIC HOSE CLAMPS, SILICONE TUBING TO PRESSURE SWITCH CONNECTIONS		2	E08-5020
HARDWARE AND COMPONENTS				
22	"Y" FITTING, 1/2" HOSE BRABS		1	E08-5025
23	CHECK VALVE, 1/4" HOSE BARBS, NOT ORIENTATION		2	E08-6538
24	VACUUM BREAKER, 1/4" HOSE BARBS, NOTE ORIENTATION		2	E08-6538

***IMPORTANT:** NOTE THE INDIVIDUAL LOCATIONS OF EACH PRESSURE SWITCH! (SEE FIG. 6.13 ON PAGE 6.17)

- The pressure switch that controls the **BOTTOM** cooking compartment system is on the **LEFT**, as viewed from the front of the unit.
- The pressure switch that controls the **TOP** cooking compartment system is on the **RIGHT**, as viewed from the front of the unit.