

# Technical Manual and Replacement Parts List

---

## Mobile Freezer



**MODEL: SKEFT34-IL 115V**

**SILVER KING REFRIGERATION INC.**

1600 Xenium Lane North, Minneapolis, MN 55441-3787  
Phone (800) 328-3329 / (763) 923-2441

**SILVER KING**®



## TECHNICAL MANUAL SILVER KING MOBILE FREEZER MODELS SKFFT34-IL

Thank you for purchasing Silver King food service equipment. Our goal is to provide our customers with the most reliable equipment in the industry today. Please read this manual and the accompanying warranty information before operating your new Silver King unit.

### UNCRATE AND INSPECT FOR DAMAGE

Upon delivery of your new Silver King unit, uncrate at once to inspect for possible freight damage following the instructions printed on the exterior of the container. Report any damages to the carrier responsible for transportation and promptly present a written claim for any evidence of mishandling. Be sure to save all packaging materials if a claim is to be filed.

### PRECAUTIONS BEFORE USING THIS PRODUCT

- This appliance is not intended for use by persons (including children) with reduced physical, sensory or mental capabilities, or lack of experience and knowledge, unless they have been given supervision or instruction concerning use of the appliance by a person responsible for their safety.

- Use caution when cleaning the condenser, the fins are very sharp.
- For units with a dual hertz rating, no adjustments are required for normal operation.

- If the supply cord is damaged, it must be replaced by the manufacturer, its service agent or similarly qualified persons in order to avoid a hazard.

- This refrigeration unit is not intended to be used at altitudes higher than 2000 meters.

- Do not store explosive substances such as aerosol cans with a flammable propellant in this appliance.

- Use caution when moving, installing, maintaining and using this refrigeration device to avoid either damaging the refrigerant tubing or increasing the risk of a leak.

- All component parts must be replaced with like components and all servicing must be done by factory authorized service personnel, so as to minimize the risk of possible ignition due to incorrect parts or improper service.

### FOR HYDROCARBON UNITS ONLY (R290)

**Danger** – Risk of fire or explosion. Flammable refrigerant used. To be repaired only by trained service personnel. Do not puncture refrigeration tubing.

**Danger** – Risk of fire or explosion. Flammable refrigerant used. Do not use mechanical devices to defrost refrigerator/freezer. Do not puncture refrigeration tubing.

**Caution** – Risk of fire or explosion. Flammable refrigerant used. Consult repair manual/owner's guide before attempting to service this product. All safety precautions must be followed.

**Caution** – Risk of fire or explosion. To be repaired only by trained service personnel. Use only Silver King approved replacement parts. Flammable refrigerant used.

**Caution** – Risk of fire or explosion. Dispose of properly in accordance with federal or local regulations. Flammable refrigerant used.



**WARNING:** This product can expose you to chemicals including lead, which are known to the State of California to cause cancer, birth defects, or other reproductive harm.

## **INSTALLATION**

The stainless steel exterior of the cabinet has been protected by a plastic covering during manufacturing and shipping. The covering can be readily stripped from the unit before installation. After removing the covering, wash the interior and exterior surfaces using a warm, mild soapy water solution and a sponge or cloth, rinse with clean water and dry thoroughly.

### **Casters**

The unit comes with the Casters installed. Check to make sure that the Casters are tightly fastened to the cabinet base to prevent damage to the base.

### **Location**

When locating the freezer, convenience and accessibility are important considerations, but the following factors must be observed:

- The unit must be level.
- Allow at least 6 inches of space at both ends to allow for proper air flow through the louvered panels. The space above the unit should be open to allow access to the product.
- Avoid placing the freezer next to ovens, heating elements or hot air sources that would affect the performance of the unit.

### **Electrical Connections**

Be sure to check the data plate, located on the liner of the cabinet, for required voltage prior to connecting the unit to power. The specifications on the data plate supersede any future discussion.

Your Silver King freezer is equipped with an eight (8) foot power cord. Any attempt to modify the plug will void the warranty, terminate the manufacturers responsibility, and could result in serious injury.

If the supply cord is damaged, it must be replaced by the manufacturer, its service agent or similarly qualified persons in order to avoid a hazard.”

The circuit must be protected with a 15 or 20 ampere fuse or breaker. The unit must be isolated on a circuit and not plugged into an extension cord.

### **Energy Rating**

Your Silver King refrigerator has a class 4 energy rating. The refrigerator was tested at an ambient temperature of 30°C (86°F) at 55% relative humidity.

**OPERATION**

**Initial Start Up**

After satisfying the installation requirements, the freezer is ready to operate. The unit will start when the power cord is connected to a live electrical receptacle. If the Compressor and Condenser Fan are not running when the unit is initially connected to power, check to make sure that the Temperature Control is not set to the 'off' position. Allow the unit to run a minimum of two (2) hours before loading it with product.

**Temperature Control**

The Temperature Control is located on the front panel of the cabinet and is factory set to maintain an average cabinet temperature of approximately 0 Degrees Fahrenheit for 115Volt units or -17 Celsius for 230 Volt units. To obtain colder temperatures, press and hold the set button until the set point value flashes. Use the up or down arrow buttons to change the value and then press the set button again. Allow the unit a minimum of one hour to respond to a control setting adjustment.

**Defrost**

The SKFMW freezer is a manual defrost unit. The unit should be defrosted whenever the walls accumulate a frost bank that is 1/2 inch thick. To defrost the unit, first remove the product and the covers from the unit then disconnect the power cord from the electrical receptacle. After the frost has melted or come loose from the cabinet walls, wipe out the cabinet interior with a sponge or position the unit over a floor drain and remove the drain plug allowing the condensate to drain out of the cabinet and into the floor drain. Do not attempt to scrape or chisel off the frost as you could do irreparable damage to the cabinet.

**MAINTENANCE**

Preventative maintenance is minimal although these few steps are very important to continued operation and maximizing the life of the appliance.

**Cabinet Surfaces**

The interior and exterior surfaces are stainless steel and should be cleaned periodically with a solution of warm water and a mild soap, rinsed with clean water and wiped dry. A good stainless steel cleaner can also be used. Should a surface become stained or discolored, do not attempt to clean with an abrasive cleaner or scouring pad. Use a soft cleaner and rub with the grain of the metal to avoid scratching the surface. Always rinse and dry afterwards. Do not use chlorinated cleaners on the stainless steel.

**Condenser**

Periodically, dust accumulated on the Condenser should be removed. First, disconnect the unit from the power supply. Remove the service panel to expose the Condenser. Remove the accumulated dust by vacuuming or blowing air through the coil. This procedure will save on Compressor running time (electrical costs) and also extend the life of the Compressor.

**WARNING: The condenser fins are very sharp, use caution when cleaning the condenser.**

**Casters**

Retighten the Casters to the base of the unit regularly to prevent damage to the base of the cabinet.

**Lids.** The exterior should be cleaned periodically. Wipe clean only with a solution of warm water and mild soap, and then wipe dry. Do not submerge or soak lids as this can cause deterioration

MODEL \_\_\_\_\_ SERIAL NO. \_\_\_\_\_ DATE INSTALLED \_\_\_\_\_

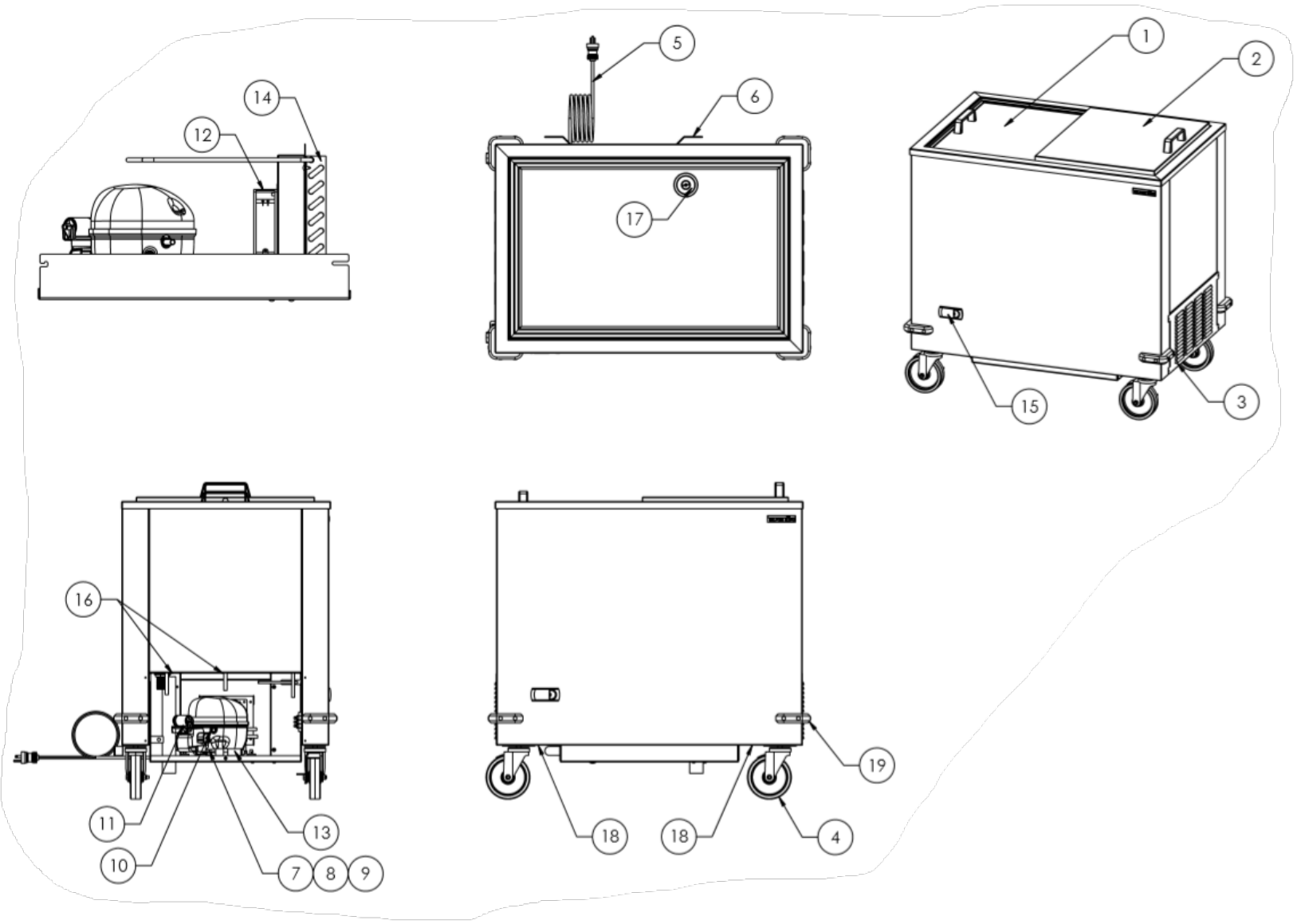

# REPLACEMENT PARTS LIST – SKEFT34-IL

ITEM NO	PART DESCRIPTION	PART NO
1	BOTTOM COVER INSULATED (SKEFT34 ONLY)	36210
2	TOP COVER INSULATED (SKEFT34 ONLY)	36214
3	END PANEL LOUVERED	35920
4	KIT 2" CASTER	10314-25
	KIT 4" CASTER	10314-79
	KIT 6" CASTER	10314-75
5	POWER CORD 115V	36144
6	CORD WRAP	37173
7	GROMMET COMPRESSOR MOUNT	20481
8	WASHER COMPRESSOR MOUNT	22401
9	CLIP HAIRPIN COMPRESSOR MOUNT	98106
10	KIT COMPRESSOR 115V/60HZ R290 (W/DRIER AND ELECTRICALS)	11700-14
11	KIT COMPRESSOR ELECTRICAL 115V (RELAY/OVERLOAD/CAPACITOR)	11701-14
12	FAN MOTOR CONDENSER 115V-230V	39577
13	DRIER	22677
14	CONDENSER COIL	39266
15	TEMPERATURE CONTROL - ELECTRONIC 115V (PROGRAMMED) BLUE LED	45705
	TEMPERATURE CONTROL - ELECTRONIC 115V (PROGRAMMED) GREEN LED	46648
16	TEMPERATURE PROBE	38822
17	STOPPER DRAIN	99649
18	GUARD BOTTOM (SKEFT34 LH/RH)	39900
19	BUMPER CORNER (OPTIONAL)	99469

FORM 45786 REV B

WHEN ORDERING REPLACEMENT PARTS, PLEASE PROVIDE MODEL AND SERIAL NUMBERS.

# WIRING DIAGRAM

39908 REV B

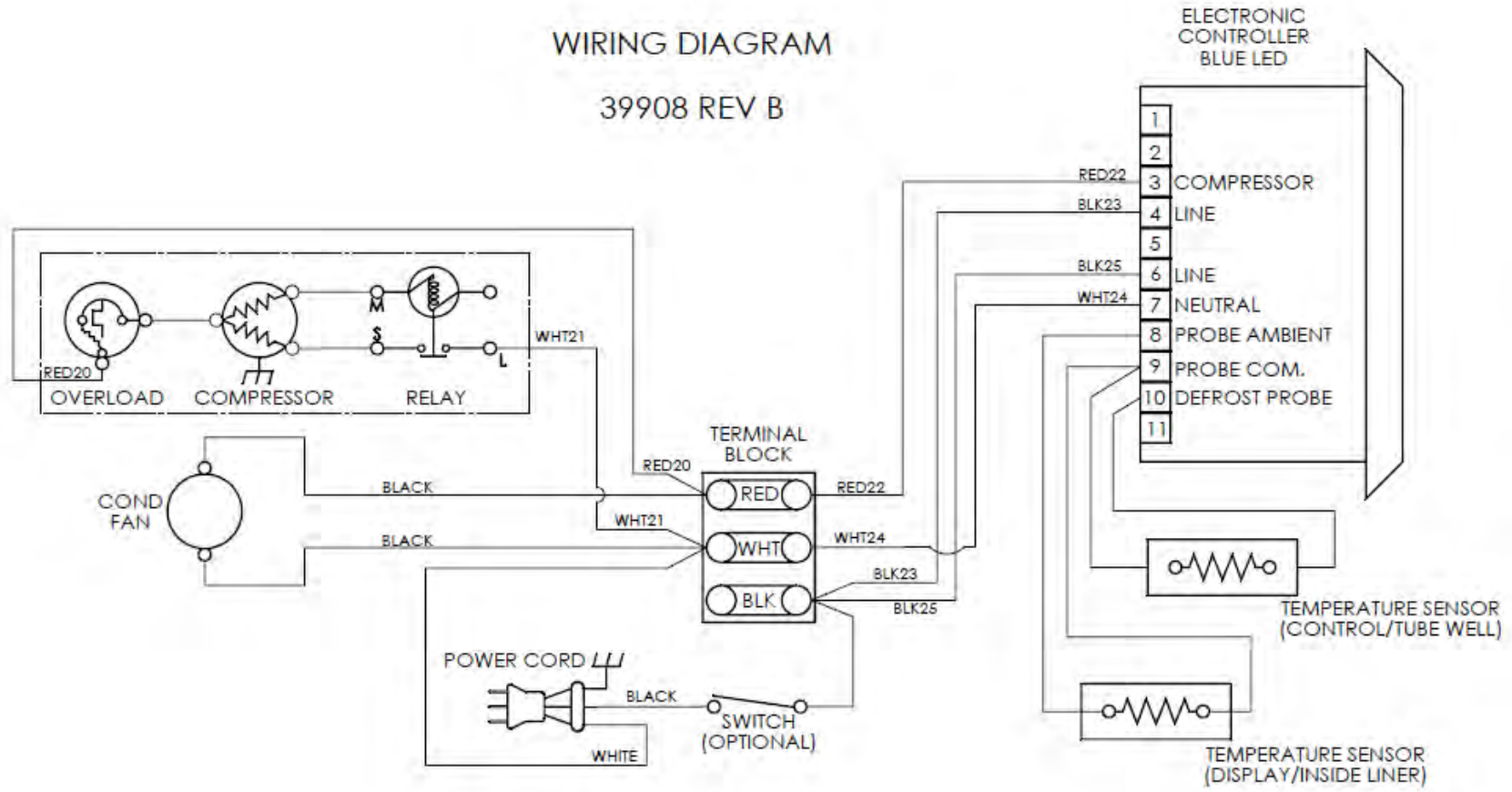

## TERMS AND CONDITIONS

### LIMITED WARRANTY

Silver King warrants to the original purchaser of Silver King refrigerated Equipment (as defined below), that the Equipment shall be free from defects in material and workmanship under normal use and service as outlined in the Technical Manual. This limited warranty shall apply for a period of time not to exceed the earlier of the following: one (1) year from the date of original purchase of the Equipment or 18 months from date of production of the Equipment. Equipment includes General Market Refrigeration units and excludes all Dispensing and Custom Holding Refrigeration or extended agreements whose written terms are conditional at time of sale or contract. All warranties are subject to specific limitations outlined below.

This limited Equipment warranty does not apply to:

- Repair or replacement required as a result of carelessness or neglect.
- Improper installation, incorrect voltage supply, modifying, tampering with or altering components and/or Equipment.
- Failure to perform proper maintenance. Equipment damaged in transit, by fire, flood or an act of God is not covered.
- Unit is compromised by adding excess weight or adhering non-approved components to the frame.
- Combining the equipment with hardware, fixtures, accessories or other equipment not provided by Silver King.
- Misuse of the Equipment or use of the Equipment not in accordance with the Technical Manual.
- Warranty excludes consumables or replacement components such as shelving, trays, gaskets, etc.
- Warranty excludes interior liner or exterior shell.

The limited Equipment warranty does not include freight, handling, installation, labor (following the one (1) year labor warranty period) or other incidental or consequential costs including product and/or economic loss. This limited Equipment warranty is in lieu of all other warranties, express or implied, are hereby disclaimed and excluded including those of merchantability, and fitness for a particular purpose. This limited Equipment warranty is non-transferable. Specific provisions of this limited Equipment warranty are as follows:

### 90 DAY REPLACEMENT PARTS WARRANTY

Silver King warrants to the original Equipment purchaser that a replacement OEM part thereof will be free of defects in material and workmanship, under normal use and service, for a period of 90 days from the date of original purchase of such replacement OEM part subject to all terms and conditions herein.

### Three (3) Year Drawer Slide Warranty

Silver King warrants to the original Equipment purchaser for a period of time not to exceed the earlier of the following: three (3) years from the date of original purchase of the Equipment or three (3) years and six (6) months from the date of shipment from the factory of the equipment, that it will replace the drawer slides with one of similar design and capacity, exclusive of delivery and installation charges, if it is found in Silver King's review to be inefficient or inoperative due to defects in material or factory workmanship.

### FIVE (5) YEAR COMPRESSOR WARRANTY

Silver King warrants to the original Equipment purchaser for a period of time not to exceed the following: five (5) years from the date of original purchase of the Equipment or five (5) years and six (6) months from the date of shipment from the factory of the Equipment, that it will replace the compressor with one of similar design and capacity, exclusive of delivery and installation charges, if it is found subject to Silver King's review to be inefficient or inoperative due to defects in material or factory workmanship. It is the original purchaser's responsibility to return the serial plate of the defective compressor, or at Silver King's option the complete compressor, to the factory. Failure to do so will void this limited compressor warranty. This limited compressor warranty shall be limited to parts only after the LIMITED WARRANTY period applicable to the Equipment has expired.

This limited Equipment warranty is limited to repairing or replacing any parts that, at Silver King's discretion, are deemed to be defective within the time period covered by this warranty. The 90 day parts warranty covers standard

freight and handling charges. Special handling charges or expedited means for transport are excluded from reimbursement. Use of non-OEM parts may, at Silver King's discretion, void this warranty. If approved, warranty credit for non-OEM parts will be issued at the OEM cost. Replacement parts sold separately are warranted for 90-days from date of purchase.

### ADDITIONAL WARRANTY GUIDELINES:

A factory issued Service Authorization Number must be obtained prior to work being performed under the one (1) year labor warranty. Contact your supplier or Silver King. Claims submitted without a Service Authorization Number will be paid at Silver King's discretion. The labor warranty includes standard straight time labor charges in accordance with Silver King's Labor Warranty Guidelines and reasonable travel time, as determined as determined in the Silver King time – rate guide.

Silver King, at its discretion, may request photos during or prior to service being dispatched to validate a technical issue. Failure to comply with the request may result in the cost of service being the responsibility of the service requestor or site.

The limited labor warranty does not cover original installation, startup, normal adjustments or maintenance. Normal adjustments and maintenance include, but are not limited to; temperature control adjustments, temperature indicator calibrations, coil and filter cleaning, or condensate drain cleaning.

A second service call for a related failure is not covered.

Use of refrigerants other than specified on the Equipment serial plate voids the warranty. All claims must include; model and serial number of equipment, date of purchase, date of failure, and a copy of the service invoice detailing the defect and service performed. No claim will be processed without this information. All claims must be filed within 30 days from date of service.

### PRODUCT ORDERING INFORMATION

Call us toll free at 1-800-328-3329 or 1-763-923-2441 Fax us at 1-763-553-1209

Visit [www.silverking.com](http://www.silverking.com) for stocking distributor, equipment specs and current price list for your area.

### SERVICE / PARTS ORDERING INFORMATION

Call us toll free at 1-800-328-3329, prompt 1 or 2

### TERMS AND CONDITIONS

- This price list and conditions are effective January 1, 2019 and supersedes all previous pricelists.
  - LIMITED WARRANTY period may vary from customer to customer and is contract specific.
  - All prices reflect payment in U.S. Dollars.
  - Prices do not include any freight, duty, or taxes.
  - Pricing subject to change without notice.
  - No returns are accepted without prior written approval from the factory. An RMA (Returned Merchandise Authorization) form must be completed and then approved by Silver King. Please contact Silver King for details. Restocking fee will apply.
  - All electrical equipment is single phase.
  - Prices, designs, and specifications are subject to change without notice.
  - Payments via credit card are subject to a 3% surcharge.
- Silver King  
1600 Xenium Lane, Plymouth, MN 55441-3706  
[www.silverking.com](http://www.silverking.com) • 1-800-328-3329

© Silver King 2019 Prices Subject To Change

