

OPERATOR'S MANUAL



Model C709 and C717 Blade Style Beater Heat Treatment Soft Serve Freezers

Original Operating Instructions

083129-M

**9/30/14 (Original Publication)
(Updated 11/8/2019)**

Section 1: To the Installer

Installer Safety	1-1
Site Preparation	1-1
Air-Cooled Machines	1-2
Water Connections	1-2
Electrical Connections	1-2
Beater Rotation	1-3
Refrigerant	1-3

Section 2: To the Operator

Section 3: Safety

Section 4: Operator Parts Identification

Model C709	4-1
Model C717	4-3
Model C709 Single-Spout Door and Beater Assembly	4-5
Model C717 Three-Spout Door and Beater Assembly	4-6
Feed Tube Assembly	4-7
Accessories	4-8
Brushes	4-9

Section 5: User Interface

Symbol Definitions	5-2
Feed Tube Assembly	5-4
Operating Screen Descriptions	5-4
Freezer Locks	5-7
Manager's Menu	5-9
Fault Description	5-13
System Information	5-16

Table of Contents

Section 6: Operating Procedures

Freezing Cylinder Assembly	6-1
Freezer Door Assembly	6-3
Feed Tube Assembly	6-6
Install Drip Pans and Splash Shield	6-7
Sanitizing	6-7
Priming	6-9
Daily Closing Procedures	6-9
Daily Opening Procedures	6-11
Setting Up	6-11
Manual Brush-Cleaning	6-12
Draining Product from the Freezing Cylinder	6-12
Rinsing	6-12
Hopper Cleaning	6-13
Disassembly	6-13
Brush-Cleaning	6-14

Section 7: Operator's Checklist

During Brush-Cleaning and Sanitizing	7-1
Troubleshooting Bacterial Count	7-1
Regular Maintenance Checks	7-1
Winter Storage	7-2

Section 8: Troubleshooting Guide

Section 9: Parts Replacement Schedule

Section 10: Limited Warranty on Equipment

Section 11: Limited Warranty on Parts

The following information has been included in the manual as safety and regulatory guidelines. For complete installation instructions, please see the Installation Checklist.

Installer Safety



IMPORTANT! In all areas of the world, machines should be installed in accordance with existing local codes. Please contact your local authorities if you have any questions.

Care should be taken to ensure that all basic safety practices are followed during the installation and servicing activities related to the installation and service of Taylor® machines.

- Only Taylor service personnel should perform installation, maintenance, and repairs on Taylor machines.
- Authorized service personnel should consult OSHA Standard 29CFR1910.147 or the applicable code of the local area for the industry standards on lockout/tagout procedures before beginning any installation or repairs.
- Authorized service personnel must ensure that the proper personal protective equipment (PPE) is available and worn when required during installation and service.
- Authorized service personnel must remove all metal jewelry, rings, and watches before working on electrical equipment.

Note: All repairs must be performed by an authorized Taylor service technician.



DANGER! The main power supply(s) to the machine must be disconnected prior to performing any installation, maintenance, or repairs. Failure to follow this instruction may result in personal injury or death from electrical shock or hazardous moving parts, as well as poor performance or damage to the machine.



WARNING! This machine has many sharp edges that can cause severe injuries.

Site Preparation

Review the area where the machine will be installed. Make sure that all possible hazards to the installer, user, and the machine have been addressed.

For Indoor Use Only: This machine is designed to operate indoors, under normal ambient temperatures of 70°F to 75°F (21°C to 24°C). The machine has successfully performed in high ambient temperatures of 104°F (40°C) at reduced capacities.



WARNING! This machine must **NOT** be installed in an area where a water jet or hose can be used. **NEVER** use a water jet or hose to rinse or clean the machine. Failure to follow this instruction may result in electrocution.



WARNING! Only install this machine in a location where its use and maintenance is restricted to trained personnel. Failure to comply may result in personal injury.



CAUTION! This machine must be installed on a level surface to avoid the hazard of tipping. Extreme care should be taken in moving this machine for any reason. Two or more persons are required to safely move this machine. Failure to comply may result in personal injury or damage to the machine.

The authorized installer should inspect the machine and promptly report any damage to the local authorized Taylor distributor.

This machine is made using USA sizes of hardware. All metric conversions are approximate and vary in size.

Air-Cooled Machines

Do not obstruct machine's air intake and discharge openings.

1 C709: A minimum of 6 in. (152 mm) air space is required on both sides and 0.0 in. on the rear of the machine.

C717: A minimum of 3 in. (76 mm) air space is required around all sides of the machine. Install the deflector provided to prevent recirculation of warm air. This will allow for adequate air flow across the condenser.

Failure to allow adequate clearance can reduce the refrigeration capacity of the machine and possibly cause permanent damage to the compressor.

Water Connections

(Water-Cooled Machines Only)

An adequate cold water supply must be provided with a hand shutoff valve. On the underside of the base pan or on the right side of the machine, two 3/8 in. IPS water connections for inlet and outlet are provided for easy hookup. Half-inch inside diameter water lines should be connected to the machine. (Flexible lines are recommended, if local codes permit.) Depending on local water conditions, it may be advisable to install a water strainer to prevent foreign substances from clogging the machine's automatic water valve. There will be only one water **in** and one water **out** connection. **Do not** install a hand shutoff valve on the water **out** line! Water should always flow in this order: first, through the automatic water valve; second, through the condenser; and third, through the outlet fitting to an **open trap drain**.



IMPORTANT! A backflow prevention device is required on the incoming water connection side. Please see the applicable national, state, and local codes for determining the proper configuration.

Electrical Connections



IMPORTANT! In the United States, this machine is intended to be installed in accordance with the National Electrical Code (NEC), ANSI/NFPA 701987.

The purpose of the NEC code is the practical safeguarding of persons and property from hazards arising from the use of electricity. This code contains provisions considered necessary for safety.

In all other areas of the world, the machine should be installed in accordance with the existing local codes. Please contact your local authorities if you have any questions.

Each machine requires one power supply for each data label on the machine. Check the data label(s) on the machine for branch circuit overcurrent protection or fuse, circuit ampacity, and other electrical specifications.

See the wiring diagram provided inside the electrical box for proper power connections.



ALWAYS FOLLOW LOCAL HEALTH CODES.



WARNING! This machine must be properly grounded. Failure to do so can result in severe personal injury from electrical shock.



IMPORTANT! An equipotential grounding lug is provided with this machine. Some countries require the grounding lug to be properly attached to the rear of the frame by the authorized installer. The installation location is marked by the equipotential bonding symbol (5021 of IEC 60417-1) on both the removable panel and the machine's frame.

**IMPORTANT!**

- *Stationary machines which are not equipped with a power cord and a plug or another device to disconnect the machine from the power source must have an all-pole disconnecting device with a contact gap of at least 0.125 in. (3 mm) in the external installation.*
- *Machines that are permanently connected to fixed wiring and for which leakage currents may exceed 10 mA, particularly when disconnected or not used for long periods, or during initial installation, shall have protective devices to protect against the leakage of current, such as a GFI, installed by authorized personnel to local codes.*
- *Supply cords used with this machine shall be oil-resistant, sheathed flexible cable not lighter than ordinary polychloroprene or other equivalent synthetic elastomer-sheathed cord (code designation 60245 IEC 57) installed with the proper cord anchorage to relieve conductors from strain, including twisting, at the terminals and protect the insulation of the conductors from abrasion.*

If the supply cord is damaged, it must be replaced by a Taylor service technician to avoid a hazard.

Beater Rotation

NOTICE! Beater rotation must be clockwise as viewed looking into the freezing cylinder.

To correct the rotation on a three-phase machine, interchange any two incoming power supply lines at the freezer main terminal block only. To correct rotation on a single-phase machine, exchange leads inside the beater motor. (Follow the diagram printed on the motor.)

Electrical connections are made directly to the terminal block provided in the main control box, located behind the service panel.

It is recommended that beater rotation adjustment be performed by an authorized Taylor service technician.

Refrigerant

CAUTION! This machine contains fluorinated greenhouse gases (F-Gas) to provide refrigeration using a hermetically sealed circuit or within foam insulation. This machine's type of gas, quantity, Global Warming Potential (GWP), and CO₂ tonnes equivalent information is recorded on the machine's data label. The refrigerant used is generally considered nontoxic and nonflammable. However any gas under pressure is potentially hazardous and must be handled with caution.

NEVER fill any refrigerant cylinder completely with liquid. Filling the cylinder to approximately 80% will allow for normal expansion.



CAUTION! Use only approved refrigerant listed on the machine's data label or authorized through a manufacturer's technical bulletin. The use of any other refrigerant may expose users and operators to unexpected safety hazards.



WARNING! Refrigerant liquid sprayed onto the skin may cause serious damage to tissue. Keep eyes and skin protected. If refrigerant burns should occur, flush the area immediately with cold water. If burns are severe, apply ice packs and contact a physician immediately.



NOTICE! Taylor reminds technicians to be aware of and in compliance with local government laws regarding refrigerant recovery, recycling, and reclaiming systems. For information regarding applicable local laws, please contact your local authorized Taylor distributor.



IMPORTANT! *Refrigerants and their associated lubricants may be extremely moisture absorbent. When opening a refrigeration system, the maximum time the system is open must not exceed 15 minutes. Cap all open tubing to prevent humid air or water from being absorbed by the oil.*

Your machine has been carefully engineered and manufactured to give you dependable operation. When properly operated and cared for, it will produce a consistent, quality product. Like all mechanical products, cleaning and maintenance will be required. A minimum amount of care and attention is necessary if the operating procedures outlined in this manual are followed closely.



IMPORTANT! This manual should be read before operating or performing any maintenance on the machine.

Your Taylor machine will **NOT** compensate for and/or correct any errors made during setup or filling operations. Thus, the initial assembly, setup, and priming procedures are of extreme importance. It is strongly recommended that all personnel responsible for the machine's operation, including assembly and disassembly, go through these procedures together to be properly trained and to make sure that all personnel understand their role in using and maintaining the machine.

If you require technical assistance, please contact your local authorized Taylor distributor.

Note: Your Taylor warranty is valid only if parts are authorized Taylor parts purchased from a local authorized Taylor distributor, and only if all required service work is provided by an authorized Taylor service technician. Taylor Company reserves the right to deny warranty claims on machines or parts if Taylor-unapproved parts or incorrect refrigerant were installed in the machine, system modifications were performed beyond factory recommendations, or it is determined that the failure was caused by abuse, misuse, neglect, or failure to follow all operating instructions. For full details of your Taylor warranty, please see the Limited Warranty section in this manual.



IMPORTANT! If the crossed-out wheeled bin symbol is affixed to this machine, it signifies that this machine is compliant with the EU directives as well as other similar end-of-life legislation in effect after August 13, 2005. Therefore, it must be collected separately after its use is completed and cannot be disposed as unsorted municipal waste.

The user is responsible for delivering the machine to the appropriate collection facility, as specified by your local code.

For additional information regarding applicable local disposal laws, please contact the municipal waste facility and/or local authorized Taylor distributor.

Compressor Warranty Disclaimer

The refrigeration compressor(s) on this machine are warranted for the term stated in the Limited Warranty section in this manual. However, due to the Montreal Protocol and the U.S. Clean Air Act Amendments of 1990, many new refrigerants are being tested and developed, thus seeking their way into the service industry. Some of these new refrigerants are being advertised as drop-in replacements for numerous applications. It should be noted that in the event of ordinary service to this machine's refrigeration system, **only the refrigerant specified on the affixed data label should be used.** The unauthorized use of alternate refrigerants will void your Taylor compressor warranty. It is the machine owner's responsibility to make this fact known to any technician he/she employs.

It should also be noted that Taylor does not warrant the refrigerant used in its machines. For example, if the refrigerant is lost during the course of ordinary service to this machine, Taylor has no obligation to either supply or provide replacement refrigerant either at billable or unbillable terms. Taylor will recommend a suitable replacement if the original refrigerant is banned, obsoleted, or no longer available during the 5-year Taylor warranty of the compressor.

From time-to-time Taylor may test new refrigerant alternates. Should a new refrigerant alternate prove, through Taylor's testing, that it would be accepted as a drop-in replacement for this machine, then the disclaimer in this "Compressor Warranty Disclaimer" section will not apply to the use of the alternate refrigerant approved by Taylor.

To find out the current status of an alternate refrigerant as it relates to your compressor warranty, call Taylor or your local authorized Taylor distributor. Be prepared to provide the model/serial number of the machine in question.

Note: *Continuing research results in steady improvements; therefore, information in this Operator Manual is subject to change without notice.*

For Units Equipped with Taylor's Remote Monitoring System

FCC / IC ID Label Placement:

- This hardware installation package includes a label that must be placed on the unit immediately after the installation of the IoT hardware device has been completed.
- The label indicates the FCC ID and Industry Canada ID for the wireless communication device. The label must be placed on the outside surface of the machine, in a manner that is visible and unobstructed.
- It is recommended that this label be placed directly adjacent to the product nameplate of this device.

FCC Compliance Statement:

- This equipment has been tested and found to comply with the limits for a Class A digital device, pursuant to part 15 of the FCC Rules.
- These limits are designed to provide reasonable protection against harmful interference when the equipment is operated in a commercial environment.
- This equipment generates, uses, and can radiate radio frequency energy, and if not installed and used in accordance with the instruction manual, may cause harmful interference to radio communications.
- Operation of this equipment in a residential area is likely to cause harmful interference, in which case the user will be required to correct the interference at his own expense.

Industry Canada Statement:

- This device complies with Industry Canada license-exempt RSS standard(s).
- Operation is subject to the following two conditions:
 - a. This device may not cause interference.
 - b. This device must accept any interference, including interference that may cause undesired operation of this device.

We at Taylor Company are concerned about the safety of the operator at all times when they are coming in contact with the machine and its parts. Taylor makes every effort to design and manufacture built-in safety features to protect both operators and service technicians.

Installing and servicing refrigeration equipment can be hazardous due to system pressure and electrical components. Only trained and qualified service personnel should install, repair, or service refrigeration equipment. When working on refrigeration equipment, observe precautions noted in the literature, tags, and labels attached to the machine, and other safety precautions that may apply. Follow all safety code requirements. Wear safety glasses and work gloves.



DANGER! Failure to adhere to the following safety precautions may result in severe personal injury or death. Failure to comply with these warnings may also damage the machine and/or its components. Such damage may require component replacement and service repair expenses.



NOTICE! DO NOT operate this machine without reading this entire manual first. Failure to follow all of these operating instructions may result in damage to the machine, poor performance, health hazards, or personal injury.



IMPORTANT! *This machine is to be used only by trained personnel. It is not intended for use by children or people with reduced physical, sensory, or mental capabilities or lack of experience and knowledge. Where limited machine operation is allowed for public use, such as a self-serve application, supervision or instruction concerning the use of the machine by a person responsible for their safety is required. Children should be supervised to ensure that they do not play with the machine.*



WARNING! Avoid injury.

- **DO NOT** operate the machine unless it is properly grounded.
- **DO NOT** operate the machine with fuses larger than specified on the machine's data label.
- All repairs should be performed by an authorized Taylor service technician.
- The main power supplies to the machine must be disconnected prior to performing installation, repairs, or maintenance.
- Machines that are permanently connected to fixed wiring and for which leakage currents may exceed 10 mA, particularly when disconnected or not used for long periods, or during initial installation, shall have protective devices to protect against the leakage of current, such as a GFI, installed by the authorized personnel to local codes.
- Stationary machines that are not equipped with a power cord and a plug or another device to disconnect the appliance from the power source must have an all-pole disconnecting device with a contact gap of at least 0.125 in. (3 mm) in the external installation.
- Supply cords used with this machine shall be oil-resistant, sheathed flexible cable not lighter than ordinary polychloroprene or other equivalent synthetic elastomer-sheathed cord (code designation 60245 IEC 57) installed with the proper cord anchorage to relieve conductors from strain, including twisting, at the terminals and protect the insulation of the conductors from abrasion.
- If the supply cord is damaged, it must be replaced by a Taylor service technician to avoid a hazard.

Failure to follow these instructions may result in electrocution. Contact your local authorized Taylor distributor for service.



WARNING! DO NOT use a water jet to clean or rinse the machine. Failure to follow these instructions may result in serious electrical shock.



WARNING! Avoid injury.

- **DO NOT** allow untrained personnel to operate this machine.
- **DO NOT** operate the machine unless all service panels and access doors are fastened with screws.
- **DO NOT** remove any internal operating parts (including, but not limited to the freezer door, beater, or scraper blades) unless all control switches are in the OFF position.

Failure to follow these instructions may result in severe personal injury, especially to fingers or hands, from hazardous moving parts.



WARNING! This machine has many sharp edges that can cause severe injuries.

- **DO NOT** put objects or fingers near the shaver or the pitcher blades.
- **USE EXTREME CAUTION** when removing blades that are very sharp.

Failure to follow this instruction may result in contaminated product or personal injury from blade contact.



CAUTION! This machine must be placed on a level surface. Extreme care should be taken when moving for any reason. Two or more persons are required to safely move this machine. Failure to comply may result in personal injury or damage to the machine.



IMPORTANT! Access to the service area of the machine is restricted to persons having knowledge and practical experience with the machine, in particular as far as safety and hygiene are concerned.



NOTICE! Cleaning and sanitizing schedules are governed by your federal, state, or local regulatory agencies and must be followed accordingly. Please refer to the cleaning section of this manual for the proper procedure to clean this machine.



CAUTION! This machine is equipped with a refrigerated cabinet designed to maintain product temperature at or below 41°F (5°C). Before replenishing the mix supply, the product must be refrigerated at or below 41°F (5°C). Failure to follow this instruction may result in health hazards and poor freezer performance.

DO NOT run the machine without product. Failure to follow this instruction can result in damage to the machine.

DO NOT obstruct air intake and discharge openings. A minimum of 3 in. (76 mm) air clearance on both sides of the machine is required. It is recommended to place the rear of the machine against the wall to prevent the recirculation of warm air. Failure to follow this instruction may cause poor freezer performance and damage to the machine.

For Indoor Use Only: This machine is designed to operate indoors, under normal ambient temperatures of 70°F to 75°F (21°C to 24°C). The machine has successfully performed in high ambient temperatures of up to 104°F (40°C) at reduced capacities.

Noise Level: Airborne noise emission does not exceed 78 dB(A) when measured at a distance of 39 in. (1.0 m) from the surface of the machine and at a height of 62 in. (1.6 m) from the floor.

C709: A minimum of 6 in. (152 mm) air space is required on both sides and 0.0 in. on the rear.

C717: A minimum of 3 in. (76 mm) air space is required around all sides. Install the deflector provided to prevent recirculation of warm air.

Model C709

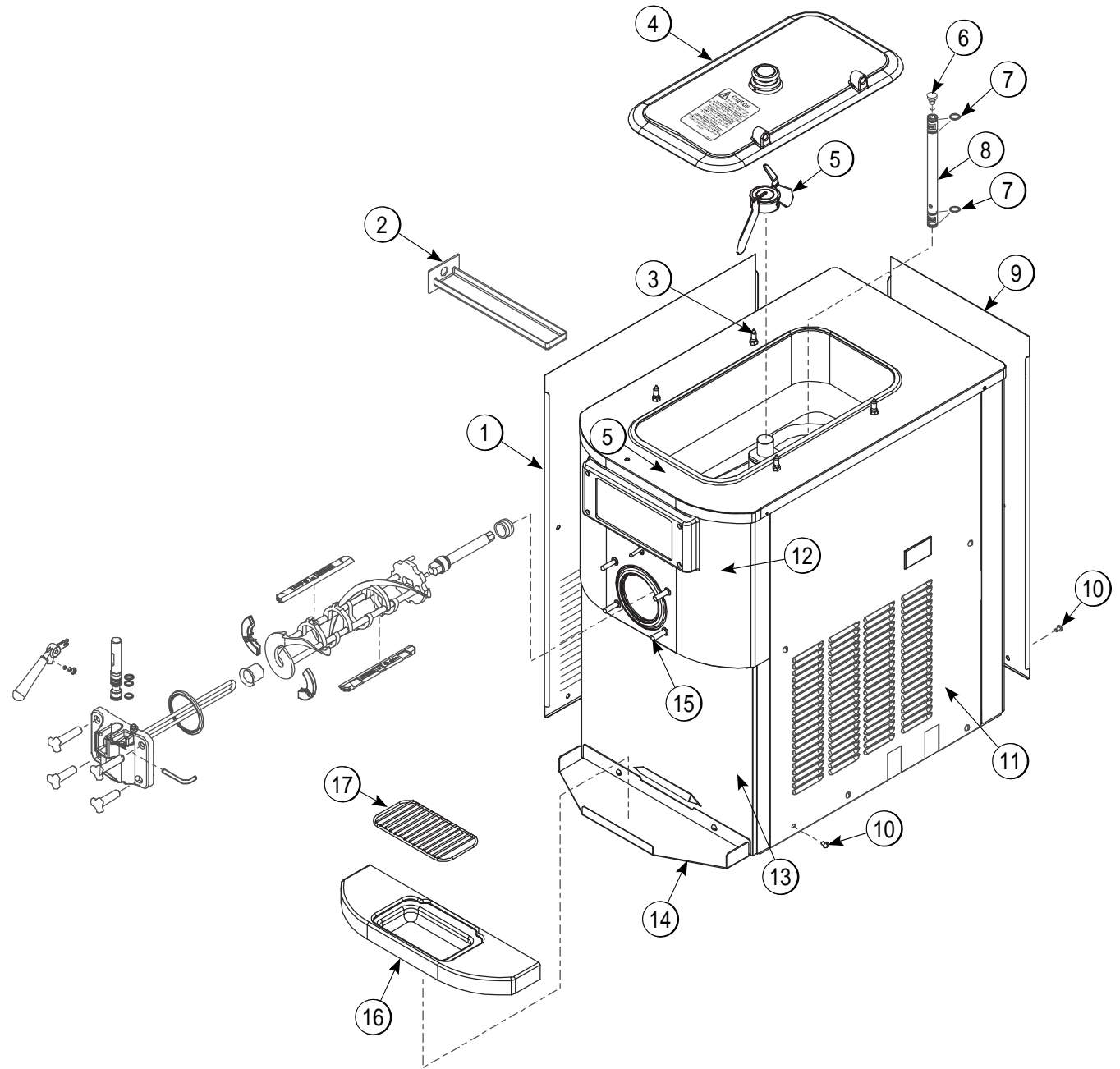

4

Figure 4-1

OPERATOR PARTS IDENTIFICATION

Model C709 Exploded View Parts Identification

Item	Description	Part No.
1	Panel-Side-Left	056963-SP1
2	Pan-Drip 11-5/8 Long	027503
3	Pin-Retaining-Hopper CVR	043934
4	Kit A.-Cover-Hopper	X65368
5	Blade A.-Agitator	X56591
6	Orifice	022465-100
7	O-ring-.643 OD x .077W	018572
8	Tube A.-Feed-SS-5/32 Hole	X29429-2
9	Panel-Rear	083017-SP1

Item	Description	Part No.
10	Screw-1/4-20x3/8 RHM-SS	011694
11	Panel-Side-Right	058932
12	Panel A.-Front-Upper	X59423
13	Panel A.-Front-Lower	X81480
14	Shelf-Tray-Drip	056076
15	Stud-Nose Cone	055987
16	Tray-Drip	056858
17	Shield-Splash	049203

Model C717

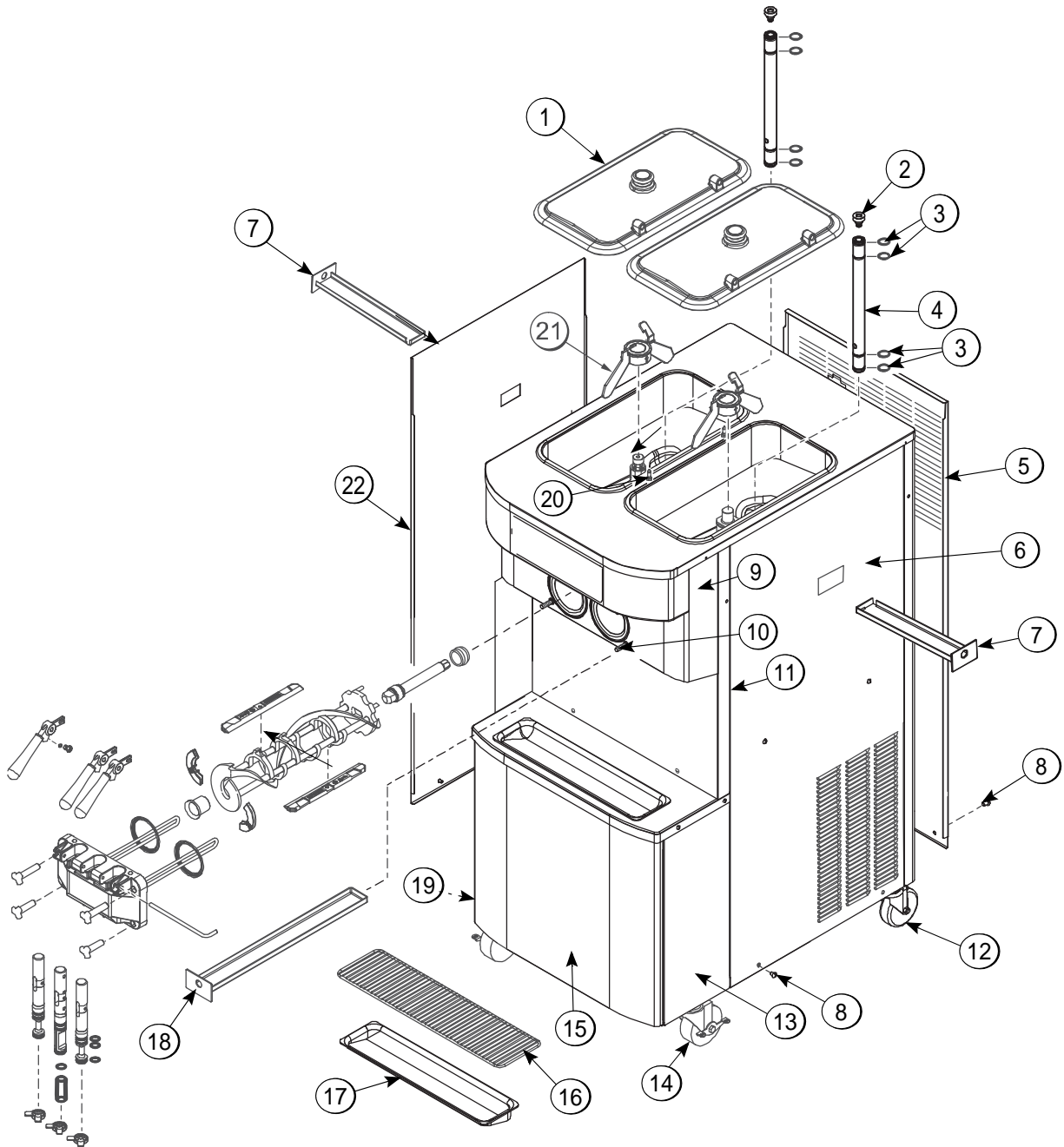

4

Figure 4-2

OPERATOR PARTS IDENTIFICATION

Model C717 Exploded View Parts Identification

Item	Description	Part No.
1	Kit A.-Cover-Hopper	X67061
2	Orifice	022465-100
3	O-ring-.643 OD x .077 Wide	018572
4	Tube A.-Feed-SS-5/32 Hole	X29429-2
5	Panel-Rear	059917
6	Panel-Side-Right	062161
7	Pan-Drip 12-1/2 Long	059736
8	Screw-1/4-20 x 3/8 RHM-SS	011694
9	Panel A.-Front(Upper)	X59836
10	Stud-Nose Cone	055987
11	Panel A.-Front(Middle)	X63879
12	Caster-4" SWV 3/4-10 STM	044106

Item	Description	Part No.
13	Panel-Corner-Frnt-Right	063087
14	Caster-4" SWV 3/4-10 Stem w/Brake	046437
15	Panel A.-Front Lower	X59854-SER
16	Shield-Splash-Wire-19-3/4	033813
17	Tray-Drip-19-5/8 L x 4-7/8	033812
18	Pan-Drip 19-1/2 Long	035034
19	Panel-Corner-Frnt-Left	063088
20	Pin-Retaining-Hopper CVR	043934
21	Blade A.-Agitator	X56591
22	Panel-Side-Left	062160

4

Model C709 Single-Spout Door and Beater Assembly

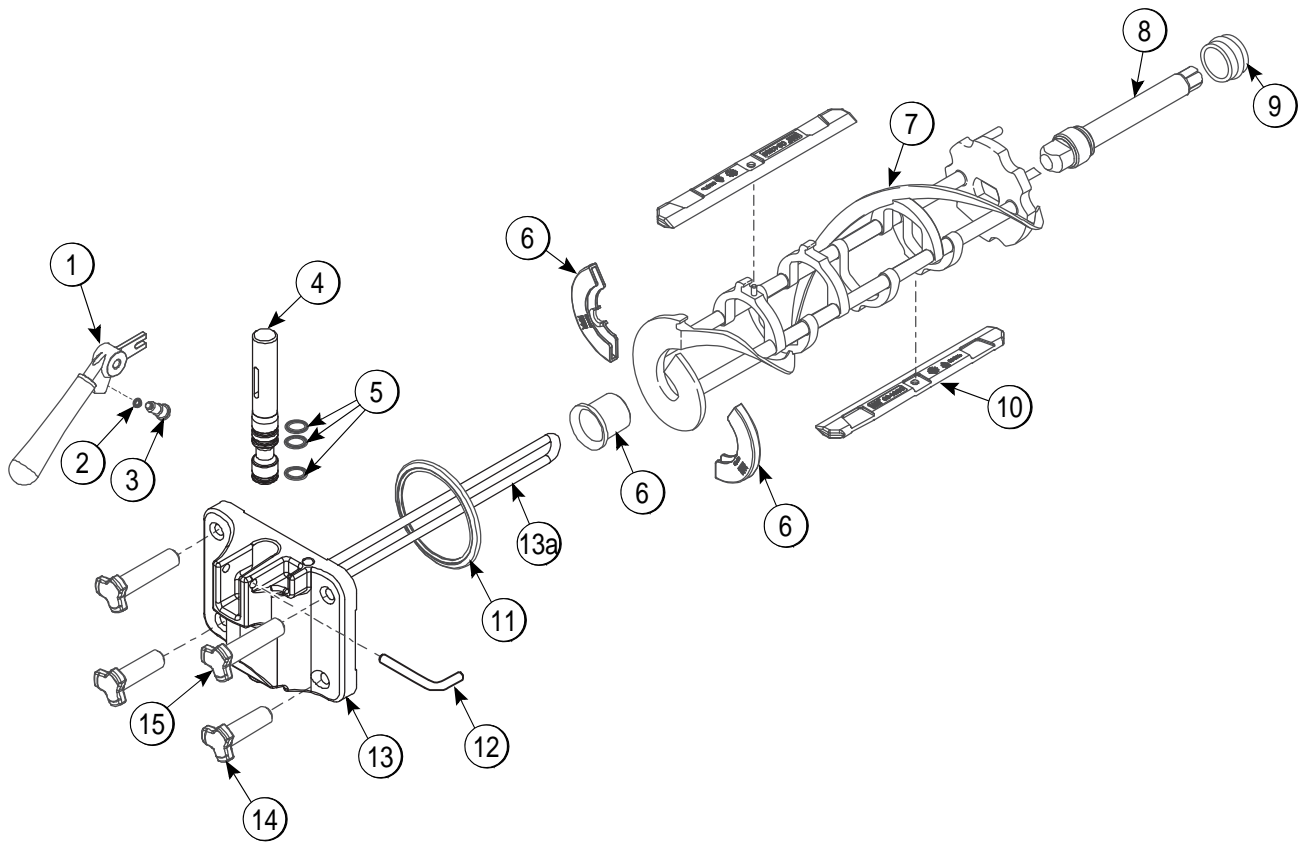

4

Figure 4-3

Item	Description	Part No.
1	Handle A.-Draw-Push	X82875
2	O-ring-1/4 OD x .070W 50	015872
3	Screw-Adjustment-5/16-24	056332-SP
4	Valve A.-Draw	X55820
5	O-ring-7/8 OD x .103W	014402
6	Kit A.-Beater-Front Shoes-Bearing	X50350
7	Beater A.-3.4QT-1 Pin	X46231
8	Shaft-Beater	056078
9	Seal-Drive Shaft	032560

Item	Description	Part No.
10	Blade-Scraper-Plastic	046235
11	Gasket-Door HT 4"-Double	048926
12	Pin-Handle-SS	055819
13	Door A.-w/Baffle	X57332-SER
13a	Baffle A.-Long 4 IN w/Rad	X50882
14	Nut-Stud-Black 2.563	058764
15	Nut-Stud-Black 3.250	058765

Model C717 Three-Spout Door and Beater Assembly

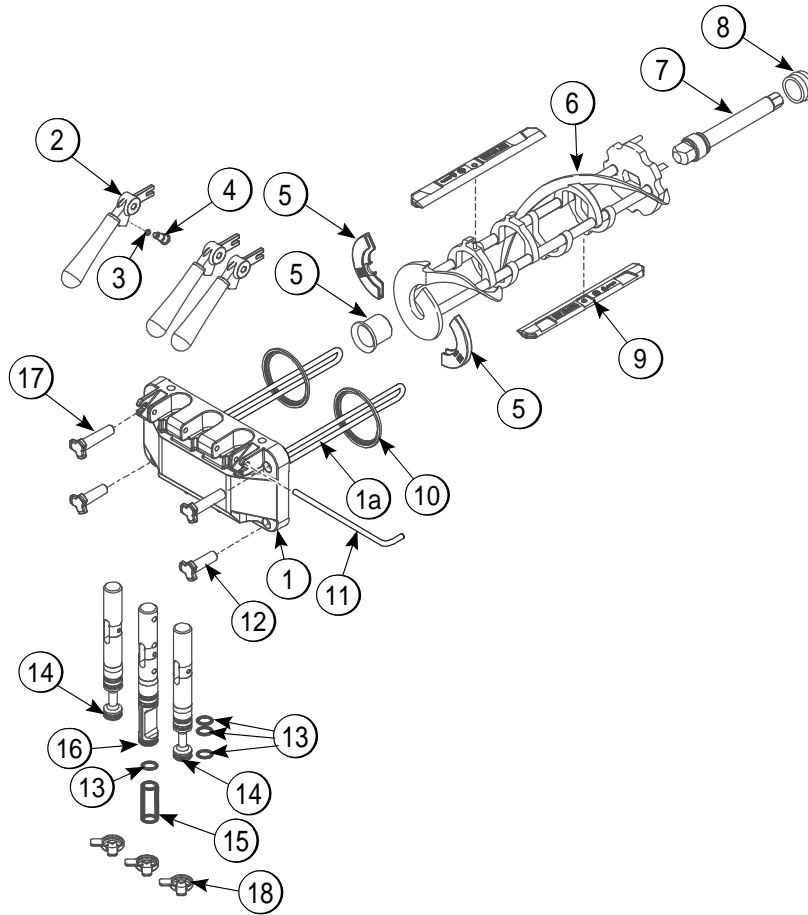
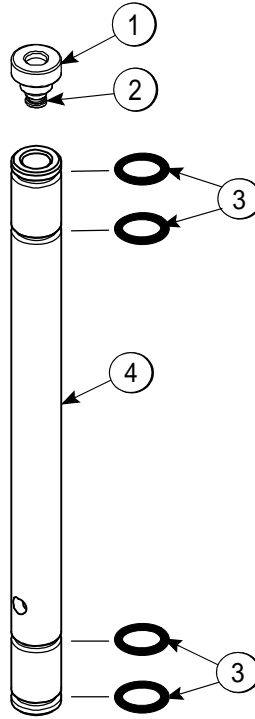

Figure 4-4

Item	Description	Part No.
1	Door A.-*LG BAF*W/O PRG*	X59923-SER
1a	Baffle A.-Long 4 IN W/RAD	X50882
2	Handle A.-Draw-Push	X82875
3	O-ring-1/4 OD x .070W 50	015872
4	Screw-Adjustment-5/16-24	056332-SP
5	Kit A.-Beater-Front Shoes-Bearing	X50350
6	Beater A.-3.4QT-1 Pin	X46231
7	Shaft-Beater	032564
8	Seal-Drive Shaft	032560
9	Blade-Scraper-Plastic	084350

Item	Description	Part No.
10	Gasket-Door HT 4"-Double	048926
11	Pin-Handle-Twin	059894
12	Nut-Stud Black 2.563 Short	058764
13	O-ring-7/8 OD x .103W	014402
14	Valve A.-Draw-Left & RT	X59888
15	Seal-Draw Valve	034698
16	Valve A.-Draw-Center	X59890
17	Nut-Stud Black 3.250 Long	058765
18	Cap-Design 1.010" ID 6 PT	014218

Feed Tube Assembly



4

Figure 4-5

Item	Description	Part No.
1	Orifice	022465-100
2	O-ring-3/8 OD x .070W	016137

Item	Description	Part No.
3	O-ring-.643 OD x .077W	018572
4	Tube A.-Feed-SS-5/32 Hole	X29429-2

Accessories

4

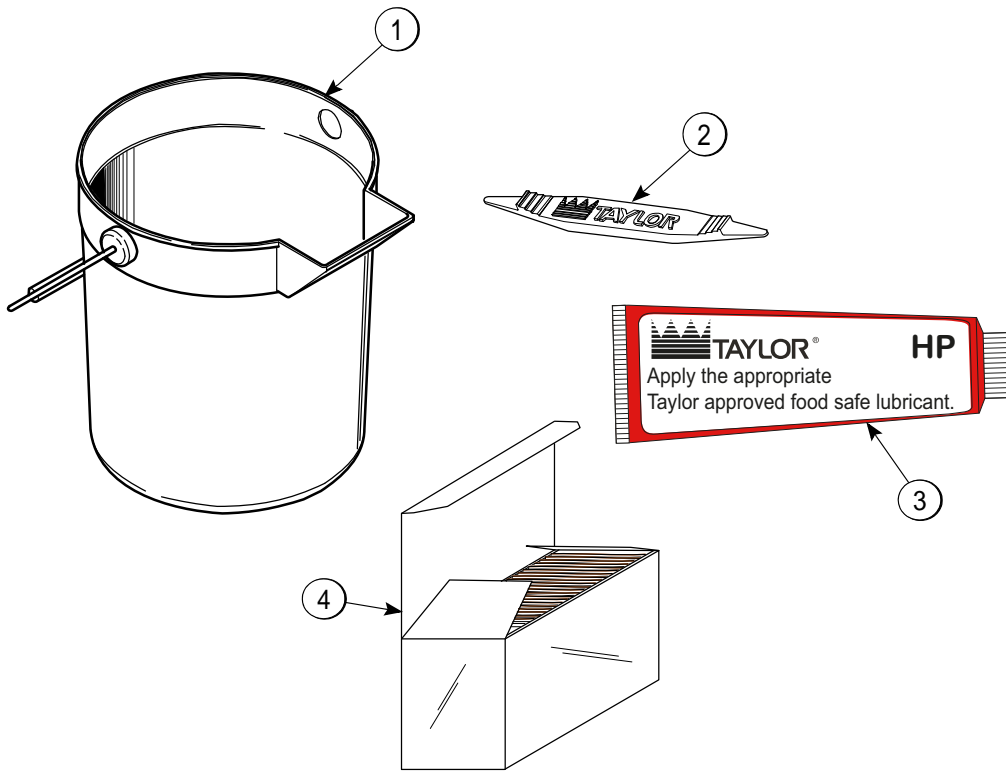

Figure 4-6

Item	Description	Part No.
1	Pail-10 QT.	013163
2	Tool-O-ring Removal Freezer	048260-WHT
3	Lubricant-Taylor HI PERF	048232
*4	Sanitizer-Stera Sheen - Green	See Note

Item	Description	Part No.
**	Kit A.-Tune Up-1 Spout (C709)	X49463-92B
**	Kit A.-Tune Up-3 Spout (C717)	X49463-79B

***Note:** A sample container of sanitizer is sent with the machine. For reorders, order Stera-Sheen® part no. 055492 (100 2 oz. packs) or Kay-5® part no. 041082 (200 packs).

**Not Shown

Brushes

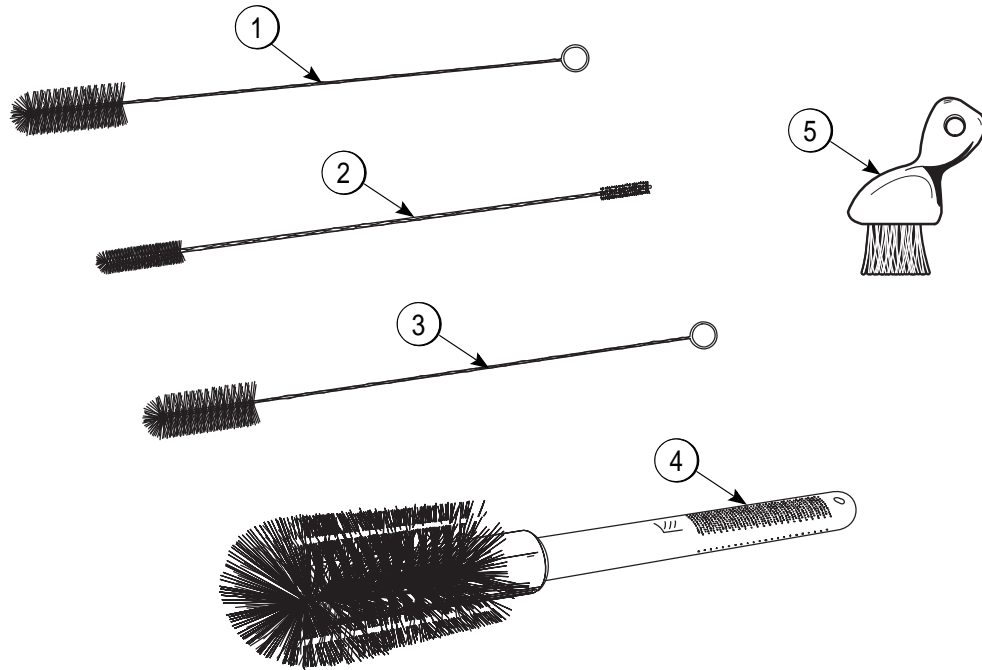

4

Figure 4-7

Item	Description	Part No.
1	Brush-Rear BRG 1" D x 2" L	013071
2	Brush-Double Ended	013072
3	Brush-Draw Valve 1"OD x 2	013073

Item	Description	Part No.
4	Brush-Mix Pump Body 3" x 7"	023316
5	Brush-End-Door-Spout-SS	039719

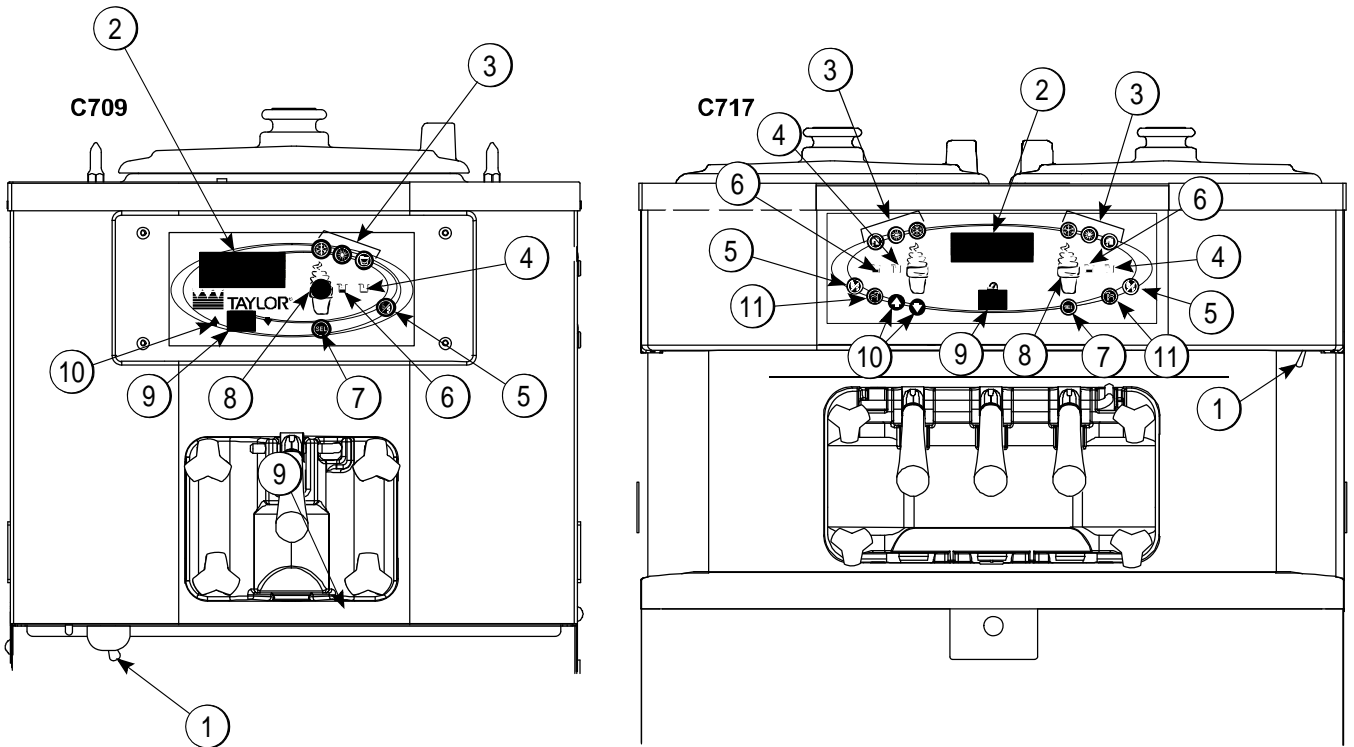

Figure 5-1

Item	Description
1	Power Switch
2	Vacuum Fluorescent Display
3	Keypads
4	Mix Out Indicator
5	Standby Key
6	Mix Low Indicator
7	Select Key
8	Menu Key
9	Brush Clean Counter
10	Arrow Keys
11	Topping Heater Key

Symbol Definitions

To better communicate in the international arena, symbols have replaced words on many of our operator switches, function, and fault indicators. Your Taylor machine is designed with these international symbols.

The following chart identifies the symbol definitions used on the machine.



= Select



= Up Arrow



=Down Arrow



= Auto



= Heat Cycle



= WASH (Model C709)



= Wash (Model C717)



= Mix Low



=Mix Out



=Menu Display



=Standby

Power Switch

When placed in the ON position, the power switch allows control panel operation.

Fluorescent Display

The fluorescent display is on the front control panel. During normal operation the display is blank. The display is used to show menu options and notifies the operator if a fault is detected. On international models, the display will indicate the temperature of the mix in the hopper.

Indicator Lights

Mix Low—When the Mix Low key  is illuminated, the mix hopper has a low supply of mix and should be refilled as soon as possible.



Mix Out—When the Mix Out  key is illuminated, the mix hopper has been almost completely exhausted and has an insufficient supply of mix to operate the machine. At this time, the Auto mode is locked out and the machine will be placed in the Standby mode. To restart the machine, add mix to the mix hopper and press

the Auto key . The machine will automatically begin operation.

Heat Mode—When the Heat mode key  is illuminated, the freezer is in the process of a Heat cycle. If enabled, the Heat key can be pressed to start a Heat cycle. If disabled, the Heat key is inoperable. By default, the Heat key is enabled.

Brush-Clean Counter—When the Brush-Clean Counter display has counted down to “1”, the machine must be disassembled and brush-cleaned within 24 hours.

Wash Key

The Wash key  (Model C709) or  (Model C717) will illuminate when it is pressed. This indicates beater motor operation. Standby or Auto modes must be canceled first to activate the Wash mode.

Auto Key

The Auto key  will illuminate when it is pressed. This indicates that the machine has been activated. In the Auto mode, Wash or Standby functions are automatically canceled.

Note: *An indicating light will illuminate and an audible tone will sound whenever a mode of operation has been selected. To cancel any function, press the key again. The light and the mode of operation will shut off.*

Standby Key

The standby feature maintains product temperature below 40°F (4.4°C) in both the hopper and the freezing cylinder. This feature is useful during long “no sale” periods to prevent overbeating and product breakdown.

If enabled, the Standby key  can be pressed to place the machine in the Standby mode. If disabled, the Standby key is inoperable.

Using sanitized hands, remove the air orifice. Place the end of the feed tube without the mix delivery hole in its side into the mix inlet hole. (See “Feed Tube Assembly” on page 5-4.)

Important! *When the feed tube is in the Standby position, make sure the level of mix in the hopper is below the mix delivery hole in the feed tube. Failure to follow this instruction may result in lower product quality when normal operation is resumed.*



When standby is selected, the Standby key  illuminates, indicating the standby feature has been activated. In the Standby mode, Wash and Auto functions are automatically canceled.

To resume normal operation, press the Auto key . When the machine cycles off, the product in the freezing cylinder will be at serving viscosity. Using sanitized hands, invert the feed tube so the end with the mix delivery hole in its side is installed in the mix inlet hole. Install the air orifice. (See “Feed Tube Assembly” on page 5-4.)

Reset Mechanism



The C709 machine's RESET button is in the service panel on the left side of the machine. The C717 machine's RESET buttons are in the rear panel of the machine.

RESET button(s) protect the beater motor(s) from overloading. Should an overload occur, the reset mechanism will trip. To properly reset the machine, place the power switch in the OFF position. Press the RESET button firmly. Turn the power switch to the ON position.

Press the Wash key  /  and observe the machine's performance.



DANGER! DO NOT use metal objects to press the RESET button. Failure to comply may result in severe personal injury or death.

If the beater motor is turning properly, press the Wash key  /  to cancel the cycle. Press the Auto key

 to resume normal operation. If the machine shuts down again, contact your a Taylor service technician.

Adjustable Draw Handle

These machines feature an adjustable draw handle(s) to provide the best portion control, giving a consistent quality to your product and controlling costs. The draw handle(s) should be adjusted to provide a flow rate of 5 oz. to 7-1/2 oz. (142 g to 213 g) of product by weight per 10 seconds. To **increase** the flow rate, turn the screw **clockwise**. To **decrease** the flow rate, turn the screw **counterclockwise**.

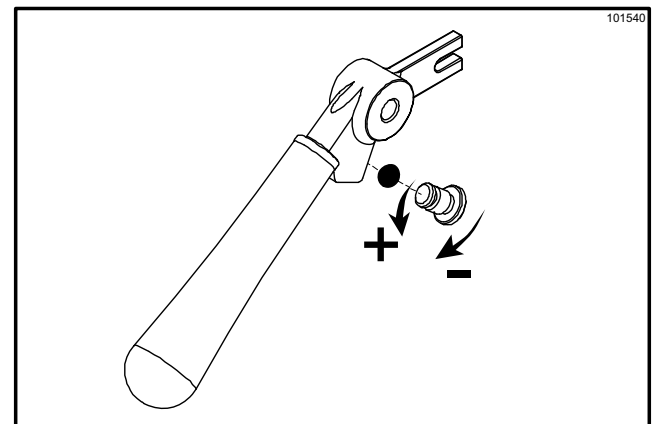

Figure 5-2

Feed Tube Assembly

The feed tube assembly serves two purposes. One end of the feed tube is equipped with a mix delivery hole in its side, and the other end does not.

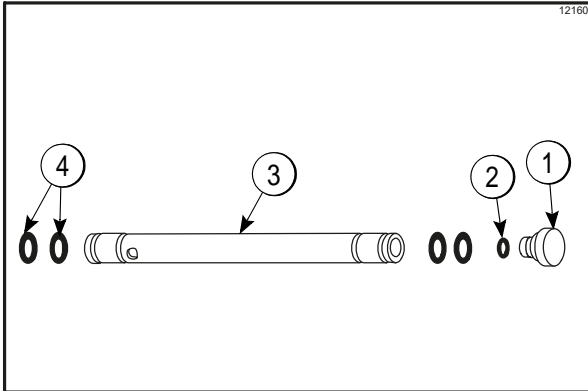

Figure 5-3

Item	Description	Part No.
1	Orifice	022465-100
2	O-ring-3/8 OD X .070 W	016137
3	Tube A.-Feed-SS 5/32 Hole	X29429-2
4	O-ring-.643 OD X .077 W	018572

1. Normal Operation

During normal operation, the end of the feed tube with the mix delivery hole is placed into the mix inlet hole. Every time the draw handle is raised, new mix and air from the hopper flow into the freezing cylinder. This keeps the freezing cylinder properly loaded and maintains overrun.

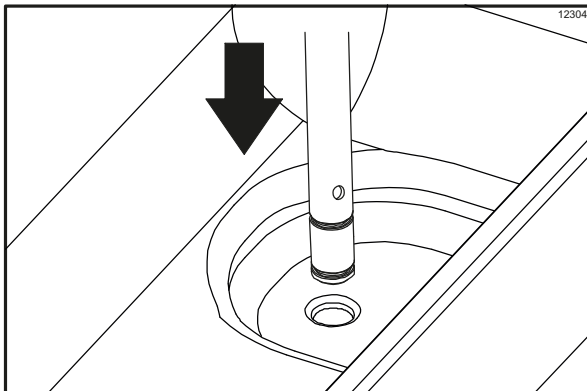

Figure 5-4

2. Long “No Sale” Periods

During long “no sale” periods, the machine can be placed into the Standby mode. This maintains product temperatures below 40°F (4.4°C) in both the hopper and the freezing cylinder and helps prevent overheating and product breakdown.

To place the machine in the Standby mode, press the Standby key. Using sanitized hands, remove the air orifice. Lubricate the O-rings located on the end of the feed tube without the mix delivery hole in its side. Place that end of the tube into the mix inlet hole. This will prevent mix from entering the freezing cylinder.

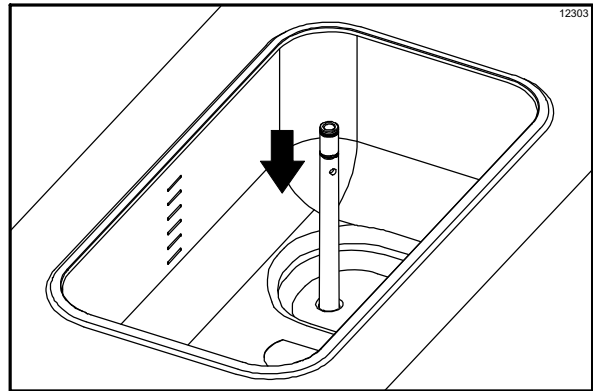

Figure 5-5

Important! When the feed tube is in the standby position, make sure the level of mix in the hopper is below the mix delivery hole in the feed tube. Failure to follow this instruction may result in lower product quality when normal operation is resumed.

Note: The air orifice is used to meter a certain amount of air into the freezing cylinder. The air orifice maintains overrun and allows enough mix to enter the freezing cylinder after a draw.

Operating Screen Descriptions

The fluorescent display in the center of the control panel is normally blank during the daily operation of the machine. The display is activated when the SEL key or the Manager's Menu is selected. The display screen will also alert the operator of specific faults detected by the control.

Note: The displays illustrated in this section are those seen on Model C709. The Model C717 displays may vary slightly.

Power-Up Memory (Initializing)

The brush-clean counter should display “00” during the initializing sequence.

When the machine is powered, the control system will initialize to perform a system check. The screen will display INITIALIZING. There are four types of data the system will check: LANGUAGE, SYSTEM DATA, CONFIG DATA, and LOCKOUT DATA.

Language Data Check

The UVC control supports multiple languages by storing language records in battery-backed memory. After power-up or a reset, a data check is performed to validate language records are present and not corrupted. If the check is successful, initialization continues. Otherwise, the operator is prompted to select a language. While the check is being performed, the following screen is displayed:

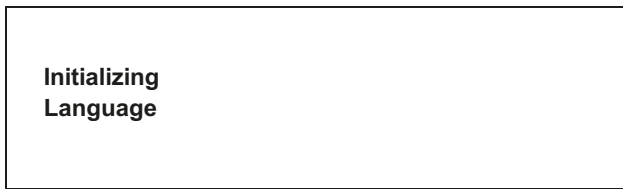

Note: *If there is a language initialization fault, the machine will prompt the operator to select a language prior to beginning the initializing sequence. Once a language has been selected, the machine will store the language selection. If the machine is powered down, the machine should not ask for a language selection again unless another language initialization fault occurs. English is the default language.*

System Data Check

System data is protected separately from the rest of the data in the machine’s memory. System data includes settings that change frequently, such as the machine mode (e.g., Auto, Wash), lockout status, serving counters, and fault codes. While system data is being checked, the following screen is displayed:



If the system data is corrupted, the machine is set to the Off mode, the serving counters are set to zero, and the faults are cleared. A “SYSTEM CRC ERR” fault is displayed on the screen. The operator must push the SEL key to acknowledge the fault.

Configuration Data Check

Configuration data is protected separately from the rest of the data in the machine’s memory. Configuration data is information programmed through the operator and service menus. While configuration data is being checked, the following screen is displayed:



If Configuration data is corrupted, all operator and service settings are reset to factory defaults. A CONFIG CRC ERR fault is displayed on the screen. The machine will continue to operate in its previous mode, but with factory default settings.

Lockout Data Check

Lockout data is protected separately from the rest of the data in the machine’s memory. While the lockout data is being checked, the following screen is displayed:

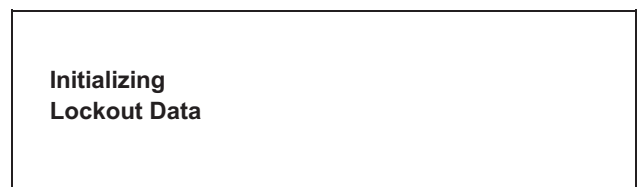

If lockout data is corrupted, all the lockout history is cleared and a LOCKOUT CRC ERR fault is displayed on the screen.

After the memory has been tested, the Safety Timeout screen will be displayed.

Heat Cycle Data Check

Heat cycle data is checked separately from the rest of the data in the machine's memory. Each Heat cycle data record is checked individually when the HEAT CYCLE DATA menu option is accessed. (For additional information, see "Heat Cycle Summary" on page 5-15.)

At the start of a Heat cycle, a Heat cycle data record is cleared, and data for the Heat cycle is written to it. The most current Heat cycle data is displayed as the first Heat cycle record in the HEAT CYCLE DATA menu option.

Once the machine has initialized, the number of days until brush-cleaning is required is indicated on the screen. The SAFETY TIMEOUT screen will be displayed with the alarm on for 60 seconds, or until any control key is pressed.

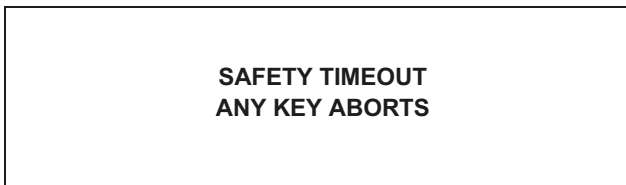

5

Power Switch OFF

After the safety timeout has been completed and the power switch is OFF, the following screen is displayed:

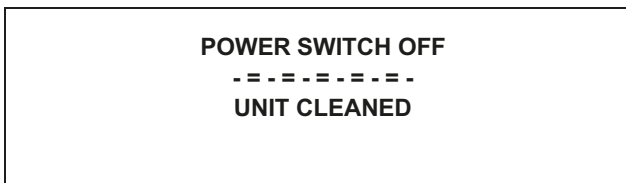

Power Switch ON

When the power switch is placed in the ON position, the control panel press keys become operative. The fluorescent display will be either blank or indicate that the machine has been cleaned.

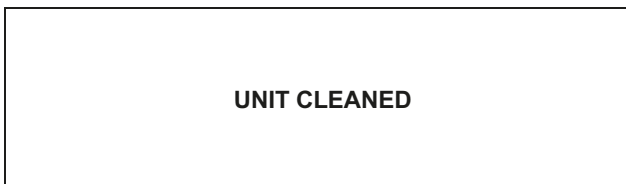

International Models Only

Some international models will continuously display the temperature of the mix hopper when the power switch is in the ON position.

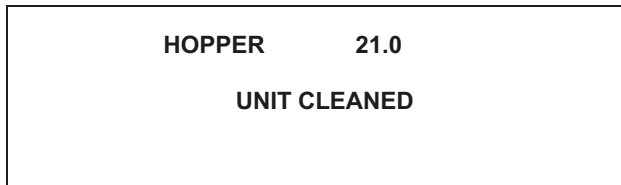

If the control is set for international configuration, the following screen will appear when the Heat key is pressed:



Use the Up or Down arrow key to move the cursor to "Yes." Press the SEL key to immediately start a Heat cycle.

Note: *The machine must be in Auto or Standby mode and have sufficient mix in the hopper before the machine can successfully enter the Heat mode of operation.*

Heat Cycle

The Heat key on the control panel is illuminated throughout the Heat Treatment cycle. Two warning messages will be displayed on the screen. DO NOT DRAW will be displayed when the mix temperature is below 130°F (54.4°C).



When the temperature of the mix is above 130°F (54.4°C), the screen will display a message indicating that HOT PRODUCT is in the machine.





WARNING! DO NOT attempt to draw product or disassemble the machine during the Heat Treatment Cycle (if equipped). The product is hot and under extreme pressure. Severe burns from hot product may result if this instruction is not followed.

In the Heat cycle, the mix temperature in the hopper and freezing cylinder must be raised to 151°F (66.1°C) within 90 minutes.

When the heating phase is complete, the machine goes into the holding phase of the cycle. The holding phase will keep the temperature above 151°F (66.1°C) for a minimum of 35 minutes.

The final phase of the Heat Treatment cycle is the cooling phase. The machine must cool the mix below 41°F (5°C) within 120 minutes.

When the entire Heat cycle has been completed, the Heat key will no longer be illuminated. The machine will enter the Standby mode (Standby key illuminates). The machine can be placed in Auto or left in Standby.

To comply with health codes, Heat Treatment system machines must complete a Heat Treatment cycle daily and must be disassembled and brush-cleaned according to the frequency specified by your federal, state, or local regulatory agencies. Please consult your governing food code to determine the maximum number of days allowed between brush-clean cycles.

Brush-cleaning is the normal disassembly and cleaning procedure found in this Operator's Manual. Failure to follow these guidelines will cause the control to lock the machine out of the Auto mode.

If the Heat Treatment cycle fails, the screen will display a failure message and return the machine to the Standby mode.

Always comply with local guidelines for the maximum number of days allowed between brush-clean cycles.

Freezer Locks

There are two types of machine lock conditions that can occur: hard lock or soft lock. A hard lock requires the machine to be disassembled and brush-cleaned. A soft lock can be corrected by either disassembling and brush-cleaning the machine or by starting another Heat Treatment cycle.

Hard Lock

There are two causes of a hard lock failure. The machine will hard lock if either the Brush-Clean Timer has elapsed or a thermistor failure (freezing cylinder or hopper) occurred during a Heat cycle.

- The following screen will be displayed if a Brush Clean Cycle Time has occurred:

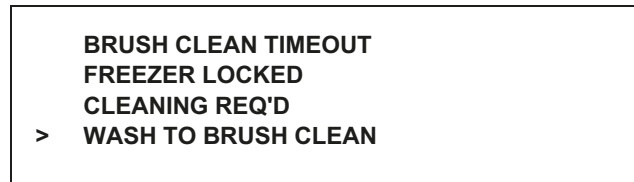

Pressing the SEL key will display the following screen:

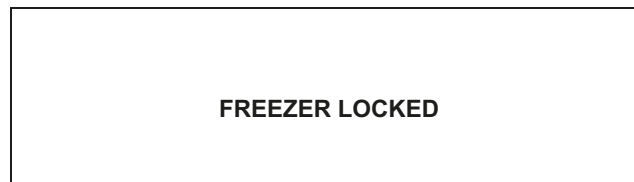

- The following screen will display if there has been a thermistor failure (freezing cylinder or hopper) during the Heat Treatment process:

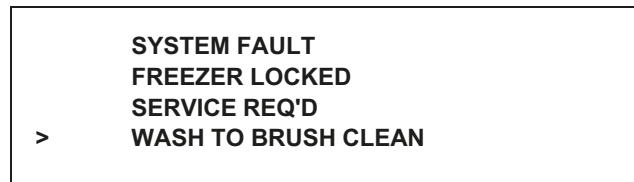

Pressing the SEL key will indicate which thermistor caused the hard lock.

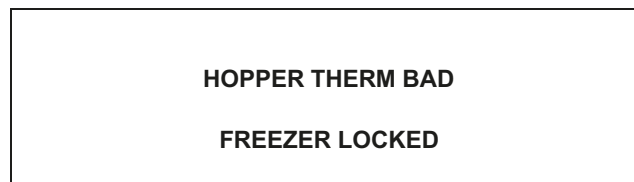

If the machine has hard locked and an attempt is made to enter Auto mode, the machine will enter the Standby mode and display the following message:

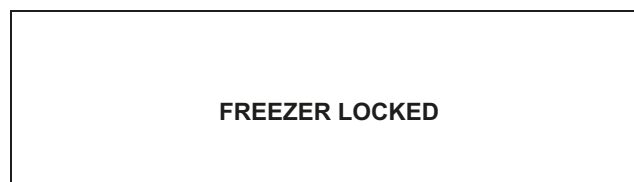

To restore the message that identified the reason for the hard lock, turn the power switch off for 5 seconds and then return the power switch to the ON position. The original message with the reason for the hard lock will be displayed.

The FREEZER LOCKED message will remain on the display until the brush-clean requirements are fulfilled. The machine must be disassembled in order to activate the 5-minute timer on the display screen. Once the timer counts down to zero, the lockout is cleared.

Soft Lock

If a Heat Treatment cycle has not been initiated within the last 24 hours, a soft lock failure will occur. A soft lock allows the operator to correct the cause of the soft lock. The operator has the option of either starting another Heat cycle or brush-cleaning the machine. When a soft lock occurs, the machine will go into the Standby mode. The following message is displayed on the screen. The reason for the soft lock is indicated on the third line.

5

```

NO HEAT CYCLE START
REASON
> HEAT FOR HEAT CYCLE
WASH TO BRUSH CLEAN
    
```

If the reason for the soft lock has been corrected, selecting HEAT CYCLE initiates a Heat cycle immediately. Selecting BRUSH CLEAN when the previous message is displayed will hard lock the machine, and brush-cleaning will be necessary.

Following are the variable messages for soft lock failures that appear on the third line of the screen.

Table 5-1

Power Switch Off	Power switch was in the OFF position.
Mix Out Present	There was a Mix Out condition present.
Auto Or Standby Off	The machine was not in the Auto or Standby mode.
No Heat Cycle Tried	A Heat Treatment cycle was not attempted in the last 24 hours. (AUTO HEAT TIME was advanced or a power loss was experienced at the time the cycle was to occur.)

If the following screen appears, a soft lock has occurred during the Heat Treatment cycle:

```

HEAT TREAT FAILURE
FREEZER LOCKED
> HEAT FOR HEAT CYCLE
WASH TO BRUSH CLEAN
    
```

A soft lock can also occur anytime during operation when the hopper or freezing cylinder temperature rises above 59°F (15°C), the temperature rises and remains above 45°F (7°C) for more than 1 hour, or the temperature rises and remains above 41°F (5°C) for more than 4 hours.

If a PRODUCT OVER TEMPERATURE condition occurs during operation, the following screen will appear:

```

PRODUCT OVER TEMP
> HEAT FOR HEAT CYCLE
WASH TO BRUSH CLEAN
    
```

When one of these messages appears, automatic machine operation cannot take place until the machine is disassembled and brush-cleaned or has completed a Heat Treatment cycle.

Once the machine is unlocked by starting a Heat Treatment cycle, the Heat key will illuminate and the following message will be displayed on the screen:

```

DO NOT DRAW
    
```

If BRUSH CLEAN is selected to clear the lockout by brush-cleaning the machine, the FREEZER LOCKED message will remain on the display until the brush-clean requirements are fulfilled. The machine must be disassembled in order to activate the 5-minute timer on the display screen. Once the timer counts down to zero, the lockout is cleared.

```

FREEZER LOCKED
    
```

To restore the message that identified the reason for the soft lock, turn the power switch off for 5 seconds and then return the power switch to the ON position. The original message with the reason for the soft lock will be displayed:

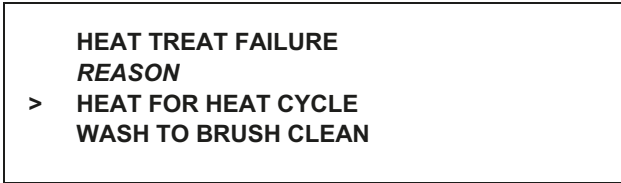

Note: A record of Heat Cycle Data and Lock Out History can be found in the Manager's Menu.

Manager's Menu

The Manager's Menu is used to enter the operator function displays. To access the Manager's Menu, press the center of the Cone key on the control panel. The arrow keys, SEL key, and Cone key will be lit when the ACCESS CODE screen is displayed.

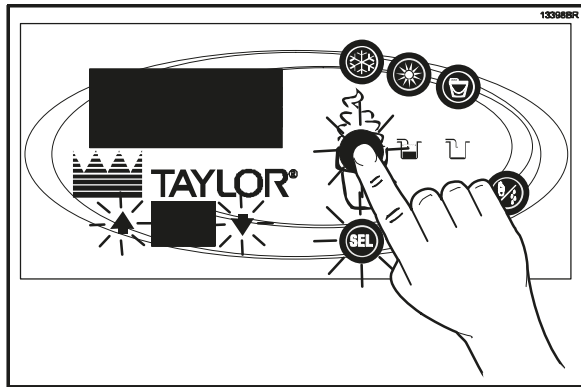

Figure 5-6

In the Manager's Menu program, the arrow keys and the SEL key will function as menu keys.

- **Up arrow**—increases the value above the cursor and is used to scroll upward in text displays.
- **Down arrow**—decreases the value above the cursor and is used to scroll downward in text displays.
- **SEL**—advances the cursor position to the right and is used to select menu options.

There is a 2-minute timeout in effect during the Manager's Menu. While in the Manager's Menu, if no activity occurs within a 2-minute period, the display will exit to the Main Menu. There is one exception to this timeout, and that is the Current Conditions Display.

Note: The machine will continue operation in the mode it was in when the Manager's Menu was selected. However, the control keys will not be lit and are nonfunctional when the Manager's Menu is displayed. The control keys are functional in the Manager's Menu when the Current Conditions screen is displayed. (See "Current Conditions" on page 5-16.)

Entering Access Code

With the ENTER ACCESS CODE screen on the display, use the SEL key to set the first code number in the cursor position. When the correct number is selected, press the SEL key to move the cursor to the next number position.

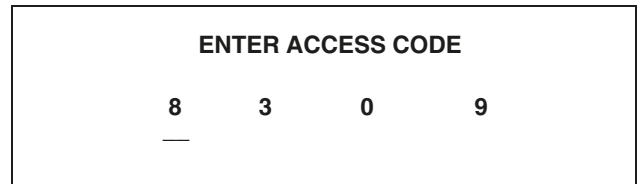

5

Continue to enter the proper access code numbers (8309) until all four numbers are displayed, then press the SEL key. The Manager's Menu list will display on the screen when the correct access code is entered.

If an incorrect number is entered for the access code, the display will exit the Manager's Menu program when the SEL key is pressed.

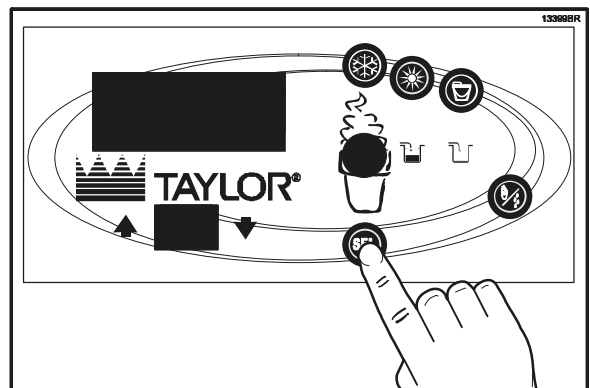

Figure 5-7

Manager Menu Options

Press the arrow keys to move up or down through the Manager's Menu. Select a menu option by pressing the SEL key. Exit the menu program by selecting EXIT FROM MENU, or press the Cone key.

The following menu options are listed in the Manager's Menu.

- EXIT FROM MENU
- SERVINGS COUNTER
- SET CLOCK
- AUTO HEAT TIME
- AUTO START TIME
- AUTO STANDBY TIME
- AGITATOR OPERATION
- MIX LEVEL AUDIBLE
- FAULT DESCRIPTION
- FAULT HISTORY
- LOCKOUT HISTORY
- HEAT CYCLE SUMMARY
- HEAT CYCLE DATA
- SYSTEM INFORMATION
- CURRENT CONDITIONS
- ENABLE WIFI

5

Exit From Menu

Selecting EXIT FROM MENU will exit the Manager's Menu and return the control panel keys to normal operation.

Servings Counter

The SERVINGS COUNTER screen is used to check or reset the number of servings dispensed from the machine. The servings counter will automatically reset to zero when the machine is brush-cleaned.

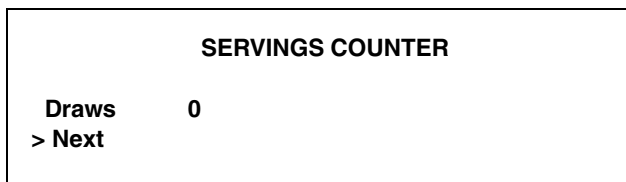

Reset the servings counter by pressing the SEL key to advance to the next screen. Press the Up arrow key to move the arrow (>) to **Yes** and press the SEL key. The servings counter will reset to zero and exit back to the Manager's Menu.



Set Clock

The SET CLOCK option allows the manager to adjust the control clock date and time. The date and time may only be changed after the freezer has been manually cleaned but before it has been placed in the Auto or Standby mode. The following message will be displayed if the SET CLOCK option is selected when the machine is not in a brush-clean state:

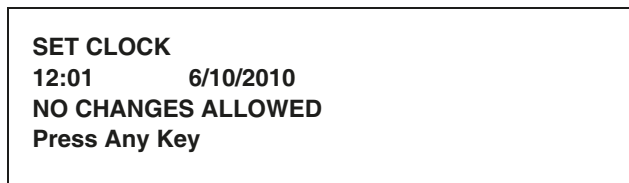

To change the date or time, select the SET CLOCK option in the menu. Press the Up arrow key to advance the arrow from Exit to Change, then press the SEL key to select the Change option.

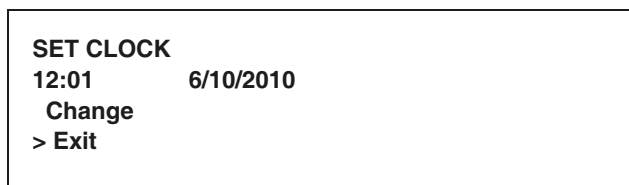

Change the time by pressing the Up arrow with the cursor under the hour position. Move the cursor to the minutes position by pressing the SEL key. Once the correct minutes are entered, press the SEL key to advance the cursor to the month.

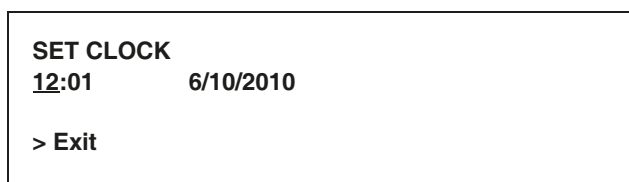

Enter the correct month, day, and year. Press the SEL key to advance to the DAYLIGHT SAVING TIME (DST) screen.

**DAYLIGHT SAVING TIME
ENABLED**

> **Enable**
Disable

Pressing the Up or Down arrow keys will move the arrow to “Enable” or “Disable.” Pressing the SEL key next to “Disable” selects that option and returns to the Manager Menu. Pressing the SEL key next to “Enable” selects that option and displays the second screen.

MAR Second Sunday
NOV First Sunday
Change
> **Exit**

If the correct Sunday for the time change is not displayed, then “Change” should be selected. Pressing the SEL key with the arrow next to “Change” displays the third screen. Press the Up or Down arrow key to move the arrow to the appropriate month for the start of Daylight Saving Time (DST).

DST START MONTH

> **MAR**
APR
MAY

Pressing the SEL key with the arrow next to the appropriate month will display the following screen:

DST START WEEK

> **Second Sunday**
Third Sunday
Fourth Sunday

Pressing the Up or Down arrow key will move the arrow to the appropriate week for the start of DST. Pressing the SEL key next to the appropriate week will display the following screen. Press the Up or Down arrow key to move the arrow to the appropriate month for the end of DST.

DST END MONTH

> **NOV**
DEC

Pressing the SEL key next to the appropriate month will display the following screen. Press the Up or Down arrow key to move the arrow to the appropriate week for the end of DST.

DST END WEEK

> **First Sunday**
Second Sunday
Third Sunday

Pressing the SEL key with the arrow by the appropriate week will select that setting and return to the Manager Menu.

Auto Heat Time

The AUTO HEAT TIME screen allows the manager to set the time of day in which the Heat Treatment cycle will start.

AUTO HEAT TIME
00:00

Change
> **Exit**

To set the AUTO HEAT TIME, press the Up arrow key to move the arrow to “Change.” Press the SEL key. The screen will display the time with the cursor under the hour position.

AUTO HEAT TIME
00:00

Press the arrow keys to increase or decrease the hour to the desired setting. Move the cursor to the minutes position by pressing the SEL key. Adjust the setting for minutes. Press the SEL key to save the setting and return to the AUTO HEAT TIME screen. Press the SEL key to exit the screen and return to the Manger’s Menu.

Auto Start Time

The AUTO START TIME option allows the manager to set the time of day at which the machine automatically enters the Auto mode from the Standby mode. The machine must be in the Standby mode without a freezer lock condition in order to Auto start at the programmable time. The AUTO START TIME can also be disabled and require starting the Auto mode manually.

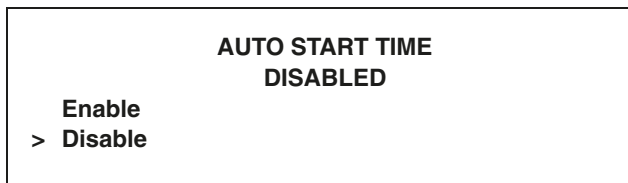

Enable the AUTO START TIME by pressing the Up arrow key to move the arrow up to "Enable." Press the SEL key to advance to the next screen.

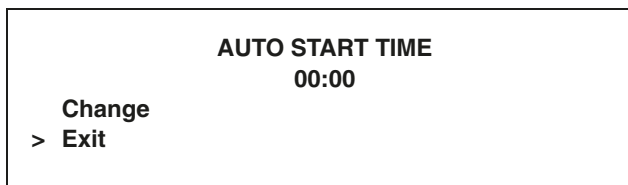

Program the AUTO START TIME by pressing the Up arrow key to move the arrow to "Change." Press the SEL key to advance to the next screen.

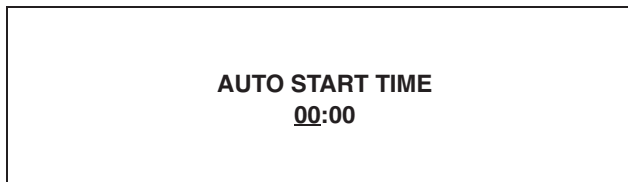

Use the arrow keys to program the AUTO START TIME by increasing or decreasing the hour setting above the cursor. Press the SEL key to advance the cursor and program the minutes setting. Press the SEL key to return to the previous screen with the new time setting displayed. Press the SEL key to exit the screen and return to the Menu.

Auto Standby Time

The AUTO STANDBY TIME option allows the manager to set the time of day at which the machine automatically enters the Standby mode from the Auto mode. This allows power saving during slow sales. By default, this feature is disabled.

Enable the AUTO STANDBY TIME by pressing the Up arrow key to move the arrow up to "Enable." Press the SEL key to advance to the next screen.



Program the AUTO STANDBY TIME by pressing the Up arrow key to move the arrow to "Change." Press the SEL key to advance to the next screen.

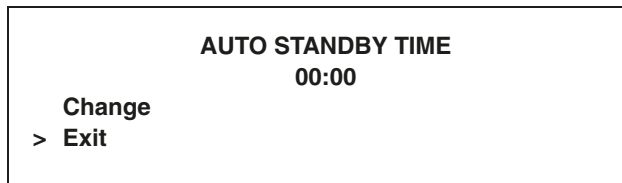

Use the arrow keys to program the AUTO STANDBY TIME by increasing or decreasing the hour setting above the cursor. Press the SEL key to advance the cursor and program the minutes setting. Press the SEL key to return to the previous screen with the new time setting displayed. Press the SEL key to exit the screen and return to the Menu.

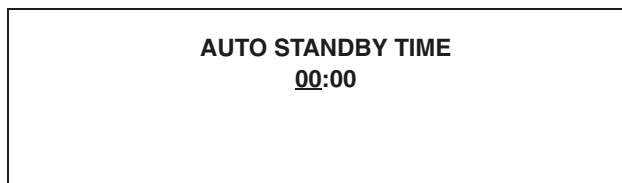

Agitator Operation

The AGITATOR OPERATION option allows the manager to select either continuous or intermittent agitator operation.

Agitator operation may be set to operate in the standard mode or "with Hopper Refrig." In the standard mode, the agitator operates during Auto, Standby, and Heat Treat. In the "with Hopper Refrig" mode, it runs only when the hopper is refrigerating and during the heat, hold, and soak phases of a Heat cycle, and the cool phase of a Heat cycle if the hopper is refrigerating. The default is "standard" operation.

```

AGITATOR OPERATION
> Standard operation
  with Hopper Refrig
  Exit
    
```

Use the arrow keys to move to the desired operation and press the SEL key to accept the selection.

Mix Level Audible

The MIX LEVEL AUDIBLE option, when enabled, will alert the operator with an audible tone when there is Mix Low or Mix Out condition. The following screen is displayed upon selecting this option:

```

MIX LEVEL AUDIBLE
      ENABLED
> Enable
  Disable
    
```

Disable the audible tone feature by pressing the Down arrow key to move the arrow to "Disable." Press the SEL key to save the new setting and return to the Menu. The control panel icons for Mix Low and Mix Out will illuminate as the mix level drops in the hopper, but the audible tone will be disabled.

Fault Description

The FAULT DESCRIPTION screen will indicate a fault with the freezer and where the fault occurred. When no faults are detected, the following screen will be displayed:

```

FAULT DESCRIPTION
NO FAULT FOUND
    
```

Press the SEL key to display the next fault found, or return to the Manager Menu if no other faults exist. Pressing the SEL key anytime faults are displayed will clear the faults, if corrected, upon returning to the Manager Menu screen.

Listed below are the variable messages which will appear, along with an explanation for the corrective action.

NO FAULT FOUND—There was no fault found in the freezer. Nothing will appear on the screen after this variable message appears.

BEATER OVERLOAD—Place the power switch in the OFF position. Wait 5 minutes for the machine to cool. Press the beater RESET button firmly. Place the power switch in the ON position and restart in Auto.

COMPRESSOR HPCO—Place the power switch in the OFF position. Wait 5 minutes for the machine to cool. Place the power switch in the ON position and restart in Auto.

HOPPER THERMISTOR FAIL*—Place the power switch in the OFF position. Call the service technician.

BARREL THERMISTOR FAIL*—Place the power switch in the OFF position. Call the service technician.

**Note: Three codes have been set up to assist in diagnosing bad thermistor probes. If a probe has shorted (resistance less than 1 ohm), "SHRT" will display for its respective machine location. If the probe is open (resistance above 1 megohm), "OPEN" will display. If the actual probe environment exceeds 200°F (93°C), the respective screen display location will read "OVER," indicating the temperature is out of range.*

COMP ON TOO LONG—The compressor run time exceeded the 11-minute timer.

Fault History

The FAULT HISTORY will display up to 100 faults that have occurred. The most recent fault is displayed on screen 1. The date, time, and fault description is displayed on each screen.

```

          FAULT HISTORY           1
          00/00/00                00:00
REASON
> Exit
    
```

Lockout History

The LOCKOUT HISTORY screen displays a history of the last 100 soft locks, hard locks, brush-clean dates, and aborted Heat cycles. Page numbers are indicated in the upper right-hand corner. Page 1 always contains the most recent failure.

LOCKOUT HISTORY	1
00/00/00	00:00
REASON	
> Exit	

The second line of the screen displays the date and time a failure occurs. The third line indicates the reason for a failure and when a successful brush-cleaning has occurred. Some failures occur with multiple reasons. When this occurs, a page will be generated for each reason.

Use the arrow keys to move forward or backward to view each screen. Listed below are the variable messages that may appear:

5 Faults - Entering Heat Treatment Cycle

POWER SWITCH OFF—The power switch is OFF.

AUTO OR STBY OFF—The control was not in the Auto or Standby mode.

MIX OUT FAILURE—A Mix Out condition was present.

NO HEAT CYCLE TRIED—The Auto Heat Time was set to attempt a Heat cycle more than 24 hours after the last successful Heat cycle.

Faults in Heat Mode

HEAT MODE FAILURE—The maximum allowable heat mode time exceeded 90 minutes.

COOL MODE FAILURE—The maximum allowable cool mode time exceeded 90 minutes for UVC3 machines or 120 minutes for UVC4 machines.

TOTAL TIME FAILURE—The maximum allowable total Heat Treatment time exceeded 4 hours.

BRUSH CLEAN TIMEOUT—The total days in operation exceeded the brush-clean cycle setting.

POWER SWITCH OFF—The power switch was turned off during the Heat cycle.

POWER FAIL IN H/C—A power failure occurred during the Heat Treatment cycle.

MIX LOW FAILURE—The mix level in the hopper is too low for a successful Heat cycle.

BEATER OVL D H/C—The overload tripped for the beater motor.

BRL THERM FAIL—The thermistor sensor for the freezing cylinder failed.

HOPPER THERM FAIL—The thermistor sensor for the hopper failed.

HPCO H/C—The high-pressure switch opened during the Heat Treatment cycle.

Faults in Auto Mode

(L/R) HPR>41F (5C) AFTER 4 HR—The mix temperature in the hopper was above 41°F (5°C) for more than 4 hours.

(L/R) BRL>41F (5C) AFTER 4 HR—The mix temperature in the freezing cylinder (barrel) was above 41°F (5°C) for more than 4 hours.

(L/R) HPR>41F (5C) AFTER PF—The mix temperature in the hopper was above 41°F (5°C) more than 4 hours following a power failure.

(L/R) BRL>41F (5C) AFTER PF—The mix temperature in the freezing cylinder (barrel) was above 41°F (5°C) more than 4 hours following a power failure.

(L/R) HPR>45F (7C) AFTER 1 HR—The mix temperature in the left or right hopper was above 45°F (7°C) for more than 1 hour.

(L/R) BRL>45F (7C) AFTER 1 HR—The mix temperature in the left or right freezing cylinder (barrel) was above 45°F (7°C) for more than 1 hour.

(L/R) HPR>59F (15C)—The mix temperature in the hopper exceeded 59°F (15°C).

(L/R) BRL>59F (15C)—The mix temperature in the freezing cylinder (barrel) exceeded 59°F (15°C).

(L/R) TOO COLD—The mix temperature in the freezing cylinder (barrel) has dropped below 10°F (-12°C).

Heat Cycle Summary

The HEAT CYCLE SUMMARY screen displays the hours since the last Heat cycle, the hours since the product temperature was above 150°F (65.6°C), and the number of Heat cycles completed since the last brush-clean date.

HEAT CYCLE SUMMARY	
HRS SINCE HC	0
HRS SINCE 150	0
HC SINCE BC	0

Heat Cycle Data

The HEAT CYCLE DATA screen contains a record of up to 366 Heat Treatment cycles. The most recent Heat cycle data will be shown first.

Each Heat cycle record has three screens. The first screen displays the month and day of the Heat cycle, the start time and end time, and the fault description. The bottom line displays the record number and indicates if a power failure occurred during the Heat cycle (POWER FAILURE IN HC).

HEAT TREAT CYCLE			
01/01	02:00	05:14	
NO FAULT FOUND			
			1

Press the Up arrow key to advance forward through the data pages. Press the Down arrow key to reverse the page direction.

Hopper and barrel temperature records for each side of the freezer are displayed in the second and third screens. The second screen shows the left side (L) of the freezer.

The third screen shows the right side (R) of the freezer.

The top line of these screens shows the hopper (H) and barrel (B) temperatures recorded at the end of the Heat Treatment cycle and indicates the side (L or R) of the freezer.

The remaining lines indicate the following.

HEAT = Total time for the hopper (h) and barrel (b) to reach 150.9°F (66.1°C).

OVER = Total time the hopper (h) and barrel (b) temperature was above 150°F (65.6°C).

COOL = Total time the hopper (h) and barrel (b) temperature was above 41°F (5°C) during the cool phase.

PEAK = Highest temperature reading for the hopper (h) and barrel (b) during the Heat Treatment cycle.

H: 40.9	B:26.3	L
HEAT	OVER	COOL
1:12	0:49 h	1:19
0:46	1:11 b	0:15
		PEAK
		161.0
		169.7

H: 38.0	B:23.7	R
HEAT	OVER	COOL
1:09	0:52 h	1:11
0:66	1:00 b	0:11
		PEAK
		161.2
		169.9

The heat time indicates the amount of time taken in each zone to reach 150.9°F (66.1°C). Each zone must remain above 150°F (65.6°C) for a minimum of 35 minutes.

Press the Up arrow key to advance to the next page or the Down arrow key to view the previous page. A Heat Cycle Failure message will display on the first screen if a failure occurred.

Note: Listed below are variable failure code messages that could appear on line 2.

Table 5-2

Code	Failure Message
HT	HEAT TIME FAILURE Mix temperature did not rise above 151°F (66.1°C) in less than 90 minutes.
CL	COOL MODE FAILURE Mix temperature in the hopper and freezing cylinder did not fall below 41°F (5°C) in less than 90 minutes for UVC3 machines or 120 minutes for UVC4 machines.
TT	TOTAL TIME FAILURE The Heat Treatment cycle must be completed in no more than 4 hours.
ML	MIX LOW FAILURE The heat phase or cool phase time was exceeded and a Mix Low condition was present.
MO	MIX OUT FAILURE A Mix Out condition was detected at the start of or during the Heat cycle.

Code	Failure Message
BO	BEATER OLVD IN HC A beater overload occurred during the Heat cycle.
PF	POWER FAILURE IN HC A power failure caused the heat phase, cool phase, or Total Cycle Time to exceed the maximum allowed time. If a power failure occurs but the Heat Treatment cycle does not fail, an asterisk (*) will appear on the third line of the display.
OP	OPERATOR INTERRUPT Indicates the Heat cycle was aborted in the OPERATOR INTERRUPT option in the Service Menu.
PS	POWER SWITCH OFF The power switch was placed in the OFF position during the Heat cycle.
TH	THERMISTOR FAILURE A thermistor probe has failed.
PD	PRODUCT DOOR OFF A product door is not in place or is loose.

System Information

The SYSTEM INFORMATION is displayed on four separate screens. The first screen contains the control and software version installed in the machine.

```

SOFTWARE VERSION
C709 CONTROL UVC4
VERSION X.XX
> Next
    
```

Press the SEL key to advance to the next system information screen containing the software language version.

```

Language
V5.01 English

> Next
    
```

Press the SEL key to advance to the next screen.

```

Bootloader
V1.13.000

> Next
    
```

Press the SEL key to advance to the system information screen containing the model bill of material and machine serial number. Pressing the SEL key again will return to the Menu list.

```

B.O.M. C700000000
S/N M0000000
Othr= 00000
> Next
    
```

Current Conditions

The Current Conditions screen provides the viscosity readings for the product when the machine is running, as well as hopper and freezing cylinder temperatures for the machine.

```

VISC 0.0
HOPPER 41.0
BARREL 41.0
    
```

Current Conditions is the only Menu screen that will return the control panel keys to normal operation. The Menu keys will not be lit when this option is selected but the panel press keys are fully functional. Exit the Current Conditions screen and return to the Menu by pressing the SEL key.

ENABLE WIFI

The ENABLE WIFI screen provides the ability to enable/disable the WIFI gateway (if the machine has the optional WIFI equipment).

Press the Up or Down arrow key to move the arrow to the appropriate selection.

Pressing the SEL key with the arrow by the appropriate selection will select that setting and return to the Manager Menu.

Once enabled, the gateway will start broadcasting its access point. This will broadcast until the machine is paired with an Internet connection, or after a 10-minute time-out.

The C709 machine stores mix in a hopper. It has a 3.4 qt. (3.2 L) freezing cylinder with a single-spout door.

The C717 machine stores mix in two hoppers. It has two 3.4 qt. (3.2 L) capacity freezing cylinders with a three-spout door.

We begin our instructions at the point when we enter the store in the morning and find the parts disassembled and laid out to air-dry from the previous night's cleaning.

The opening procedures in this section will show you how to assemble the parts into the machine, sanitize them, and prime the machine with **fresh** mix in preparation to serve your first portion.

If you are disassembling the machine for the first time or need information to get to this starting point in our instructions, turn to "Disassembly" on page 6-13, and start there.

Freezing Cylinder Assembly

Note: When lubricating parts, use an approved food grade lubricant (example: Taylor Lube HP).



WARNING! Make sure the power switch is in the OFF position! Failure to follow this instruction may result in severe personal injury to fingers or hands from hazardous moving parts.

The Model C709 has been selected to illustrate the step-by-step operating procedures. Duplicate the procedures, as directed, for the second freezing cylinder on the Model C717.

1. Lubricate the groove on the beater driveshaft.

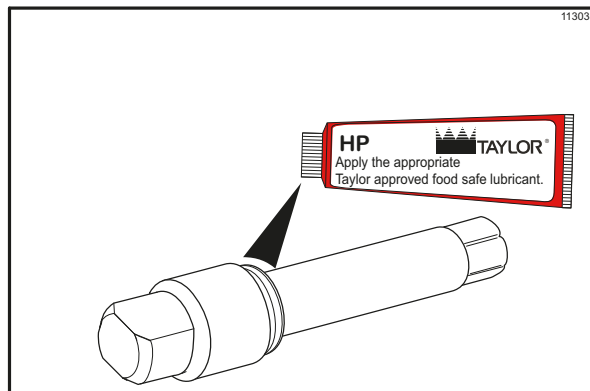

Figure 6-1

2. Slide the beater driveshaft seal over the small end of the beater driveshaft and engage into the groove on the shaft.

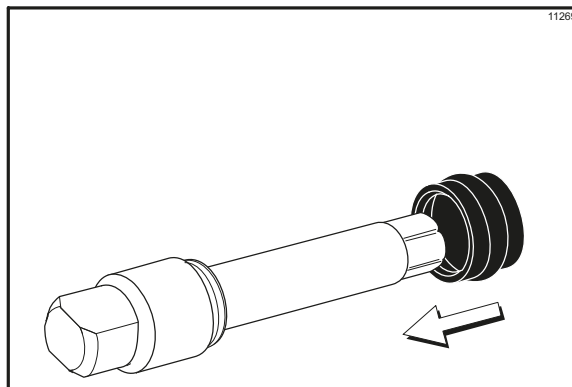

Figure 6-2

Note: To make sure mix does not leak out of the back of the freezing cylinder, the middle section of the driveshaft seal should be convex or extending out from the seal. If the middle section of the seal is concave or extending into the middle of the seal, turn the seal inside out.

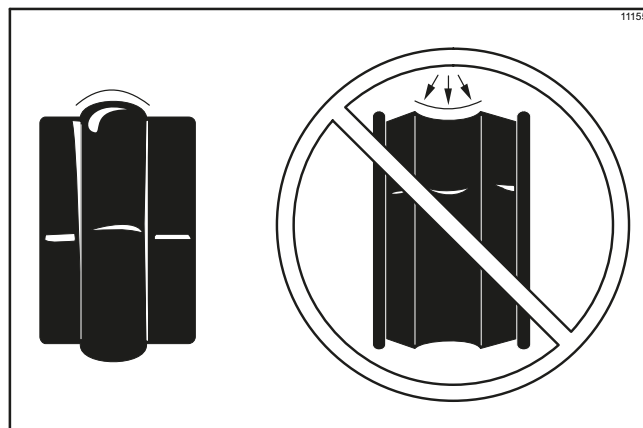

Figure 6-3

OPERATING PROCEDURES

3. Heavily lubricate the inside portion of the driveshaft seal and also lubricate the flat end of the seal that comes in contact with the rear shell bearing. (See Figure 6-4.)

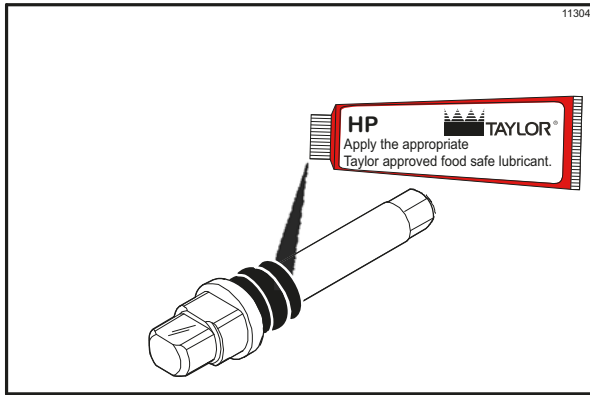

Figure 6-4

4. Apply an even coat of lubricant to the shaft. **Do not** lubricate the hex end. (See Figure 6-5.)

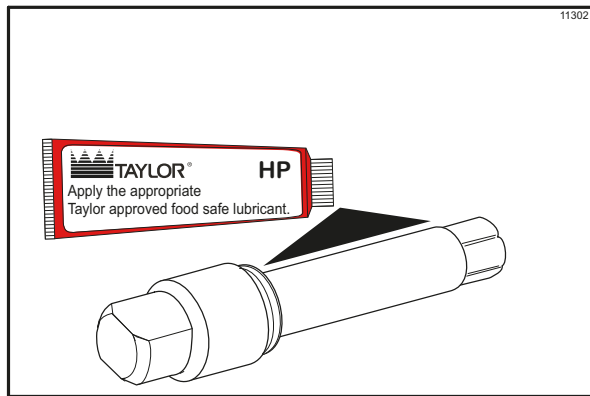

Figure 6-5

5. Insert the beater driveshaft through the rear shell bearing in the freezing cylinder and engage the hex end firmly in the drive coupling.

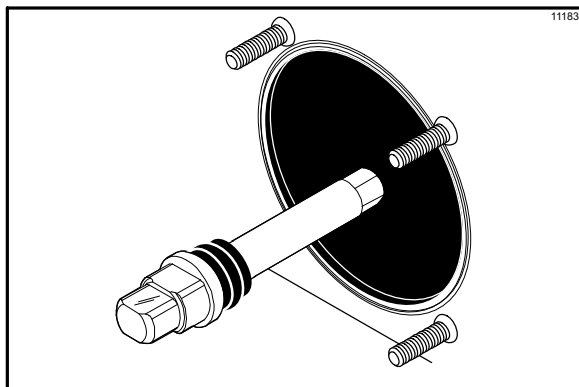

Figure 6-6

Note: After inserting the driveshaft into the freezing cylinder, use a single-service paper towel to remove any excess lubricant that was displaced from the driveshaft seal when it was installed onto the rear shell bearing.



WARNING! Use extreme caution when handling the beater assembly. The scraper blades are very sharp and may cause injury.

6. Before installing the beater assembly, look down the length of the parallel bars of the beater to make sure the bars are straight with one another. If they are not straight, the beater is bent and must be replaced. Check the scraper blades for any signs of wear or damage. If a scraper blade is nicked or worn, replace both blades.

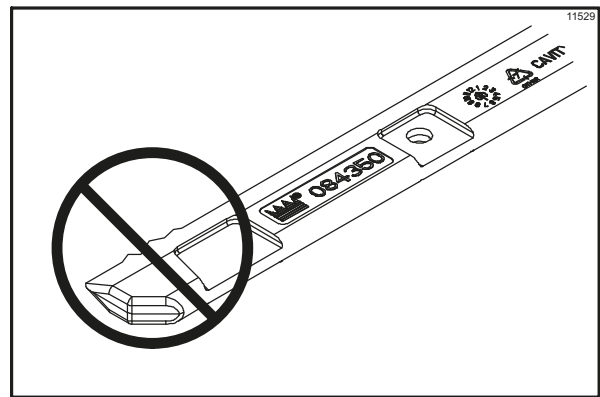

Figure 6-7

7. If the blades are in good condition, place the rear scraper blade over the rear holding pin on the beater. To prevent damage, make sure the hole on the scraper blade fits securely over the pin. (See Figure 6-8.)

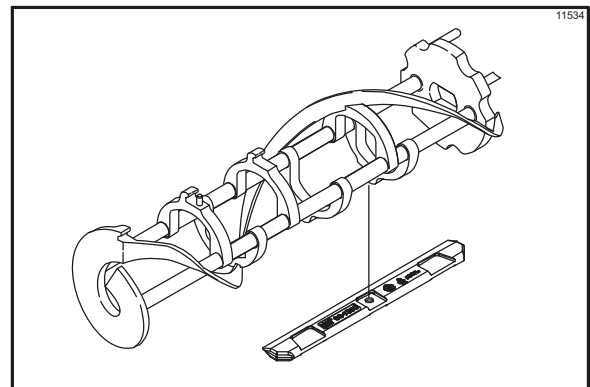

Figure 6-8

Note: *Scraper blades should be replaced every 3 months.*

8. Holding the rear blade on the beater, slide it into the freezing cylinder halfway. Install the front scraper blade over the front holding pin. (See Figure 6-8.)

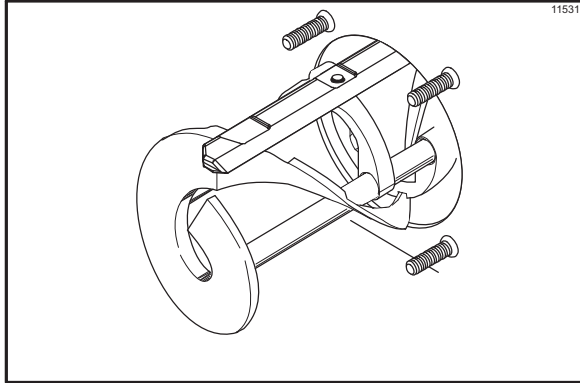

Figure 6-9

9. Before installing the beater shoes, check the shoes for any nicks, cracks, or signs of wear. If any defects are present, replace the beater shoes.
10. If the beater shoes are in good condition, install the beater shoes. (See Figure 6-10.)

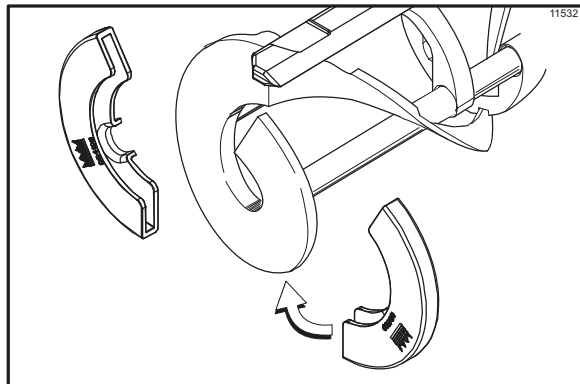

Figure 6-10

11. Slide the beater assembly the rest of the way into the freezing cylinder.

Make sure the beater assembly is in position over the driveshaft by turning the beater slightly until the beater is properly seated. When in position, the beater will not protrude beyond the front of the freezing cylinder. (See Figure 6-11.)

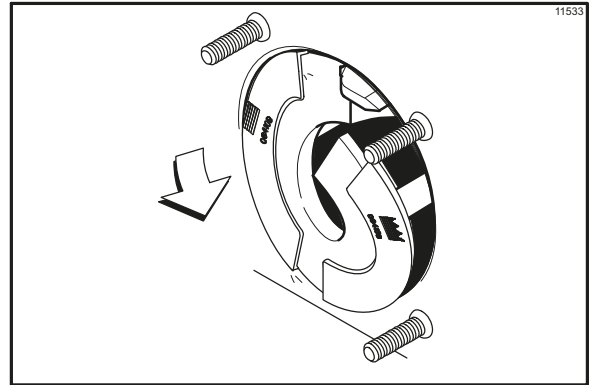

Figure 6-11

12. Repeat steps 1 through 11 for the other side of the C717.

Freezer Door Assembly

The assembly of the C709 freezer door is different from the C717 freezer door. Please follow the appropriate instructions for your machine.

Model C709 Freezer Door Assembly

1. Before assembling the freezer door, check the following for any nicks, cracks, or signs of wear: the door bearing, door gasket, draw valve, O-rings, and all sides of the door assembly, including the inside of the draw valve bore. Replace any damaged parts.
2. If the parts are in good condition, place the door gasket into the groove on the back of the freezer door. Slide the front bearing over the baffle rod so the flanged edge is against the door. **Do not** lubricate the gasket or bearing.

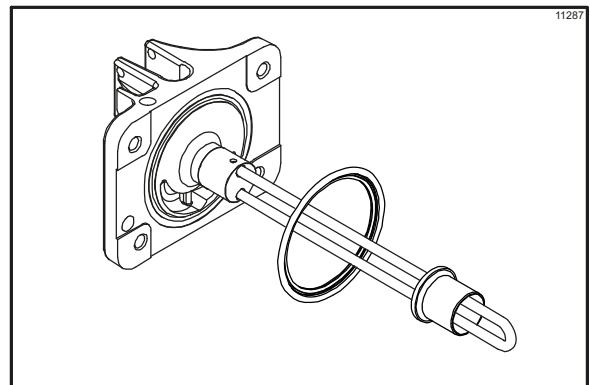

Figure 6-12

OPERATING PROCEDURES

- Slide the three O-rings into the grooves on the draw valve and lubricate.

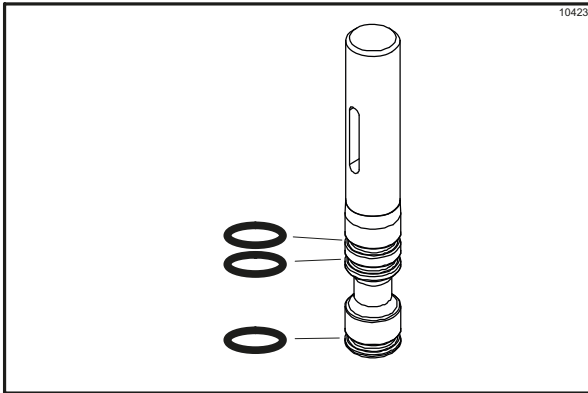

Figure 6-13

- Lightly lubricate the inside of the top of the freezer door valve cavity.

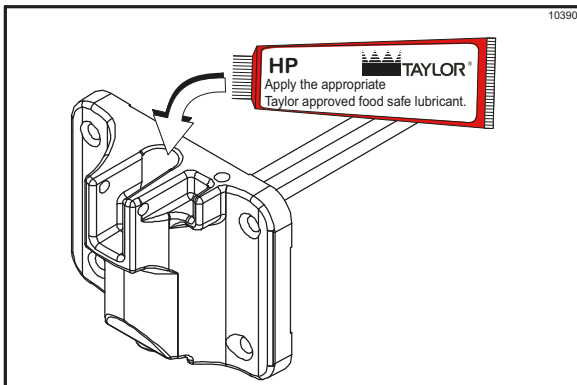

Figure 6-14

- Insert the draw valve from the top, with the draw handle slot facing forward.

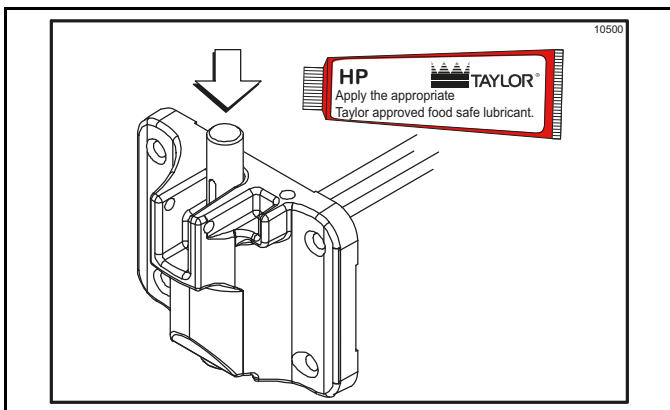

Figure 6-15

- Insert the baffle rod through the beater in the freezing cylinder. With the door seated on the freezer studs, install the handscrews with the longer ones on top. Tighten equally in a crisscross pattern to make sure the door is secured.

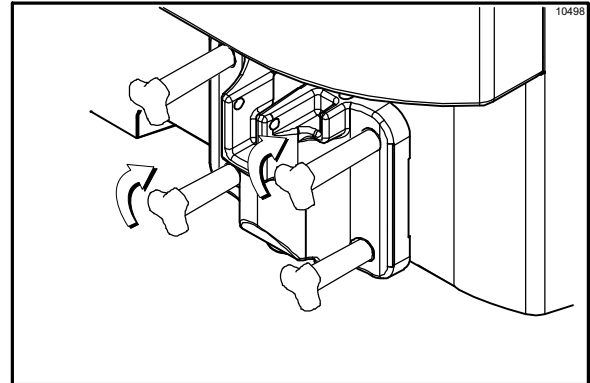

Figure 6-16

- Position the draw handle with the adjustment screw facing down. Slide the fork of the draw handle into the slot of the draw valve. Secure with the pivot pin.

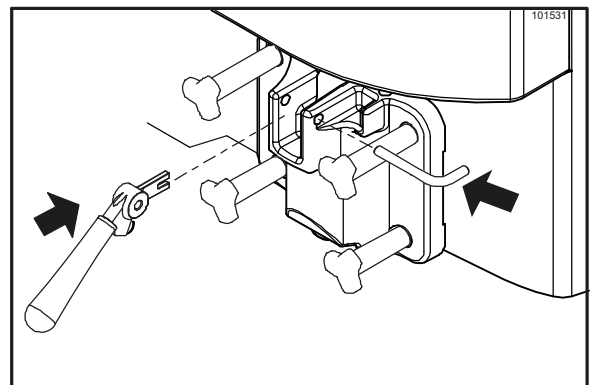

Figure 6-17

Note: The C709 features an adjustable draw handle to provide portion control, giving a better, consistent quality to your product and controlling costs.

The draw handle should be adjusted to provide a flow rate of 5 oz. to 7-1/2 oz. (142 g to 213 g) of product by weight per 10 seconds. To **increase** the flow rate, turn the adjustment screw **clockwise**. Turn the adjustment screw **counterclockwise** to **decrease** the flow rate.

Model C717 Freezer Door Assembly

The assembly of the C717 freezer door is different from the C709 freezer door. Please follow the appropriate instructions for your machine.

1. Before assembling the freezer door, check the following for any nicks, cracks, or signs of wear: the door bearings, door gaskets, draw valves, O-rings, and all sides of the door assembly, including the inside of the draw valve bores. Replace any damaged parts.
2. Place the door gaskets into the grooves on the back of the freezer door.

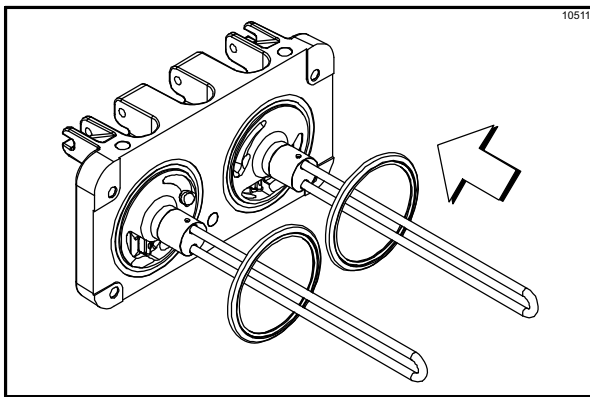

Figure 6-18

3. Slide the front bearings over the baffle rods. The flanged edges should be against the door. **Do not** lubricate the gaskets or bearings.

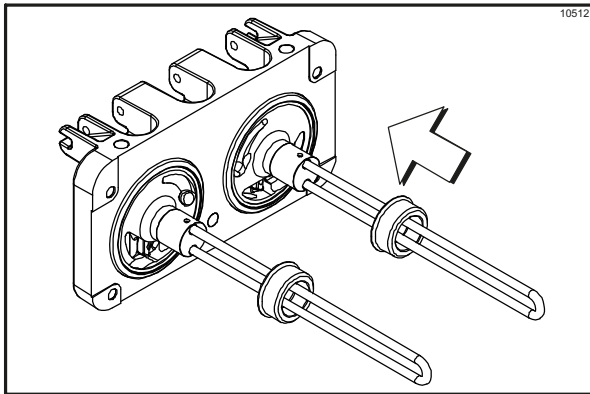

Figure 6-19

4. Insert the baffle rods through the beaters in the freezing cylinders. With the door seated on the freezer studs, install the handscrews with the longer ones on top. Tighten equally in a crisscross pattern to make sure the door is secured.

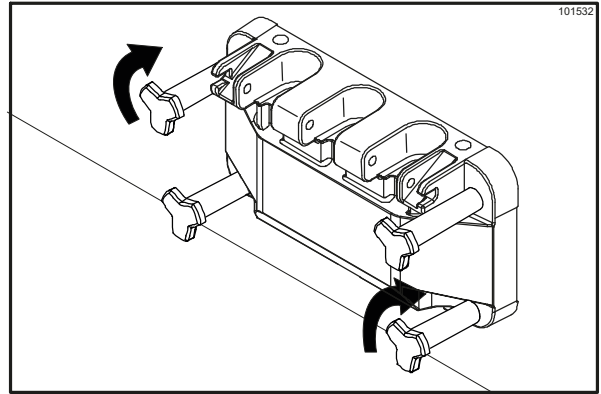

Figure 6-20

5. Slide the three O-rings into the grooves of each standard draw valve. Slide the H-ring and O-ring into the grooves of the center draw valve. Lubricate the H-ring and O-rings.

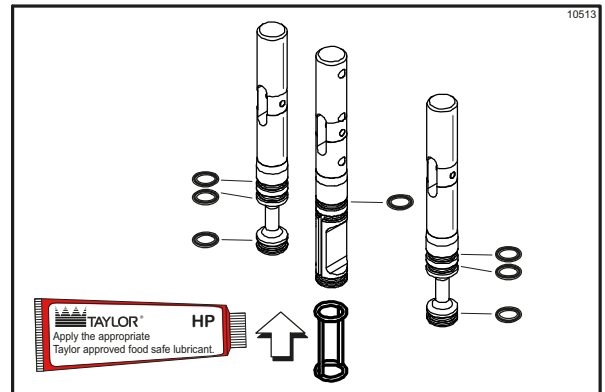

Figure 6-21

6. Lubricate the inside of the freezer door spouts, top and bottom.

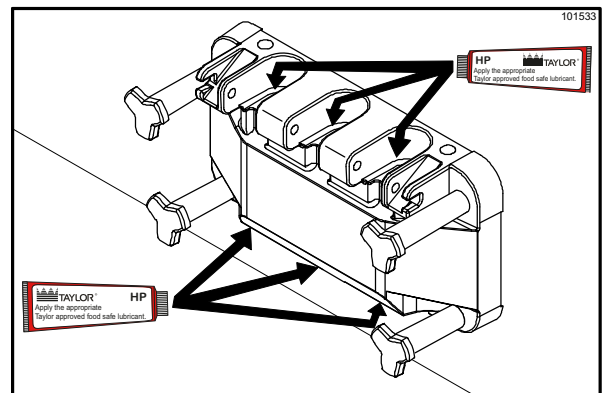

Figure 6-22

OPERATING PROCEDURES

7. Insert the draw valves from the bottom until the slot in each draw valve comes into view.

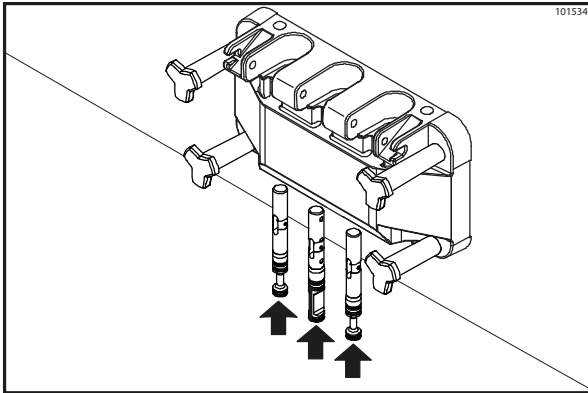

Figure 6-23

8. Position each draw handle with the adjustment screw facing down. Slide the fork of each draw handle into the slot of each draw valve, starting from the right.
9. Slide the pivot pin through the draw handles as the handles are inserted into the draw valves.

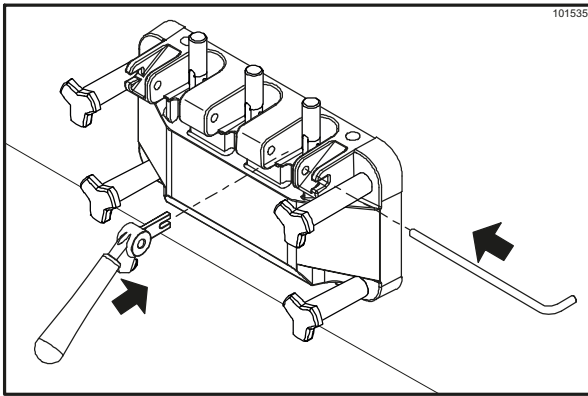

Figure 6-24

Note: This freezer features adjustable draw handles to provide portion control, giving a better consistent quality to your product and controlling costs. The draw handles should be adjusted to provide a flow rate of 5 oz. to 7-1/2 oz. (142 g to 213 g) of product by weight per 10 seconds.

To **increase** the flow rate, turn the adjustment screw **clockwise**. To **decrease** the flow rate, turn the adjustment screw **counterclockwise**.

10. Snap the design caps over the bottom of the door spouts.

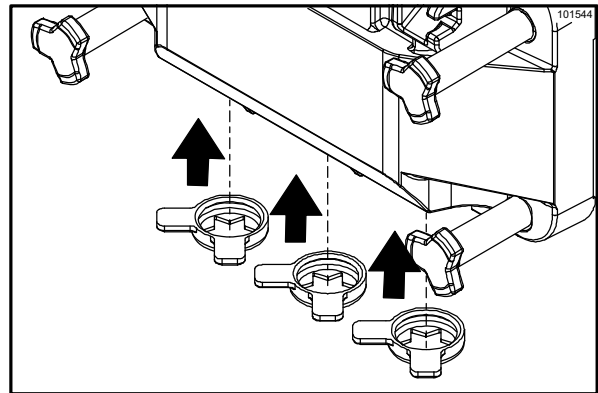

Figure 6-25

Feed Tube Assembly

1. Slide two O-rings on one end of the feed tube. Slide two O-rings on the other end of the feed tube.

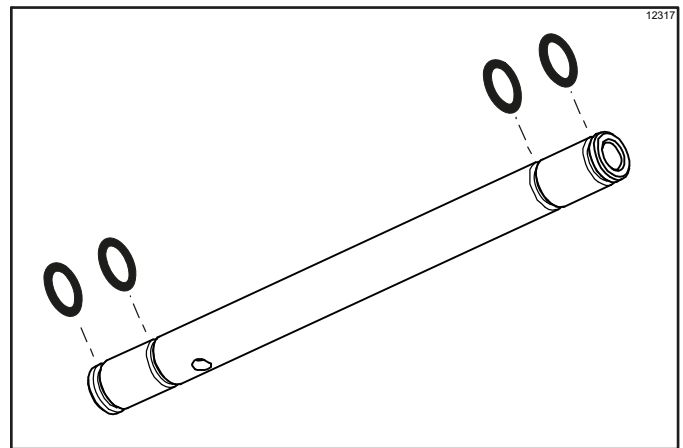

Figure 6-26

2. Slide the small O-ring into the groove of the air orifice. Do not lubricate the O-ring.

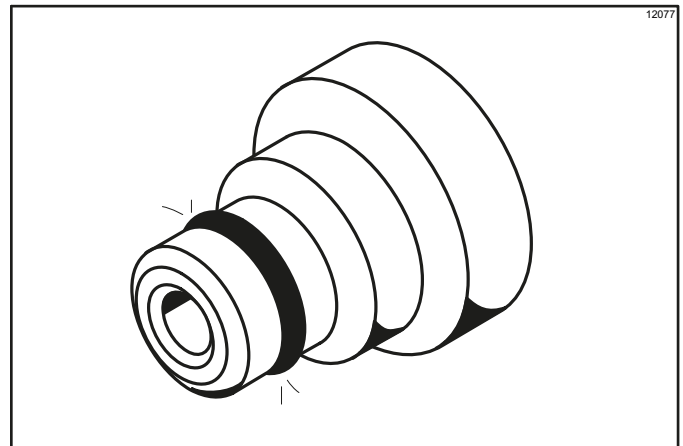

Figure 6-27

Note: Make sure the hole in the air orifice is clean and is not clogged. If the hole in the air orifice should become clogged, use soap and hot water to clear the hole. **Do not** enlarge the hole in the air orifice.

3. Install the air orifice into the hole in the top of the feed tube (end without the mix delivery hole on the side).

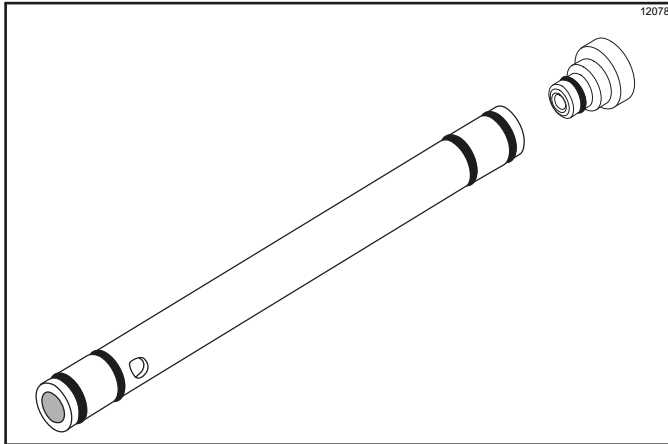

Figure 6-28

4. Lay the feed tube (with the air orifice installed) and the agitator in the bottom of the mix hopper for sanitizing.

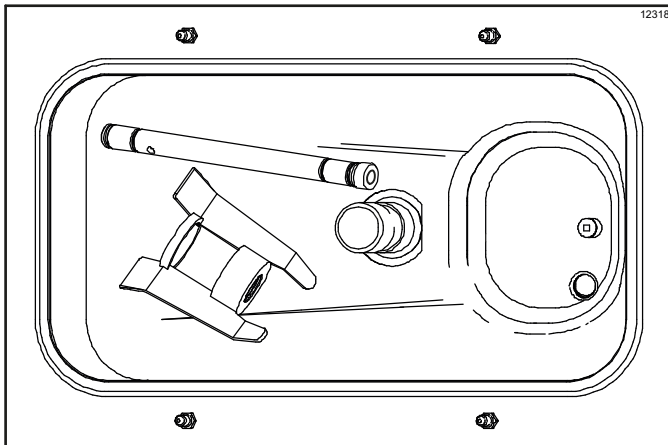

Figure 6-29

5. Repeat steps 1 through 4 for the other side of the C717.

Install Drip Pans and Splash Shield

1. **Model C709:** Slide the drip pan into the hole in the left panel.

Model C717: Slide the long drip pan into the hole in the front panel. Slide the other two drip pans into the holes in the side panels. (See Figure 6-30.)

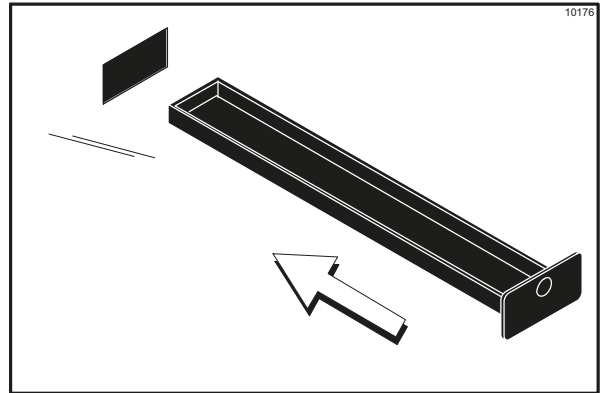

Figure 6-30

2. Install the front drip tray and splash shield under the door spout(s). (See Figure 6-31.)

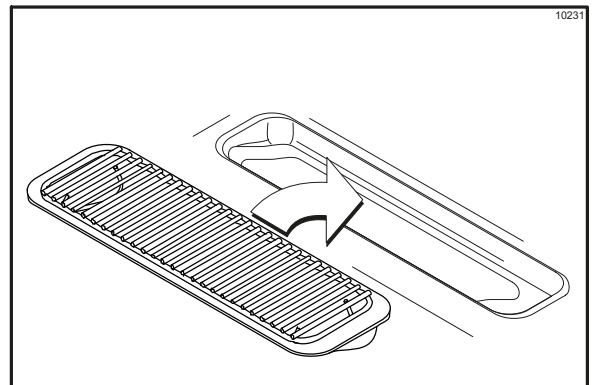

Figure 6-31

Sanitizing

1. Prepare a 2-1/2 gal. (9.5 L) pail of a Taylor-approved cleaning/sanitizing solution with an active chlorine concentrate of 100 PPM–200 PPM (examples: 2 gal. [7.6 L] of Stera-Sheen® or 2-1/2 gal. [9.5 L] of Kay-5®).

Important! Use warm water and follow the cleaning/sanitizing solution manufacturer's specifications.

OPERATING PROCEDURES

2. Pour the sanitizing solution over all the parts in the bottom of the mix hopper and allow it to flow into the freezing cylinder.

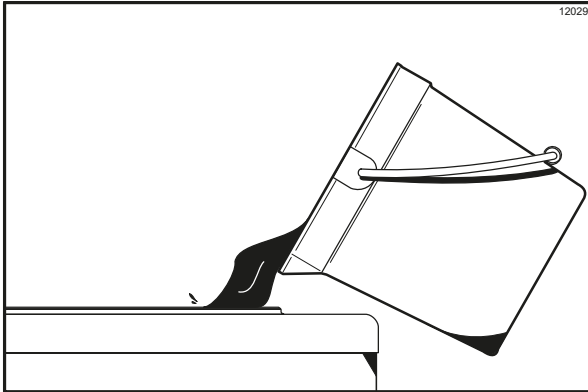

Figure 6-32

Note: You have just sanitized the mix hopper and parts; therefore, make sure your hands are clean and sanitized before going on in these instructions.

3. While the solution is flowing into the freezing cylinder, take particular care to brush-clean the mix-level sensing probe on the bottom of the hopper, mix hopper, mix inlet hole, and feed tube.

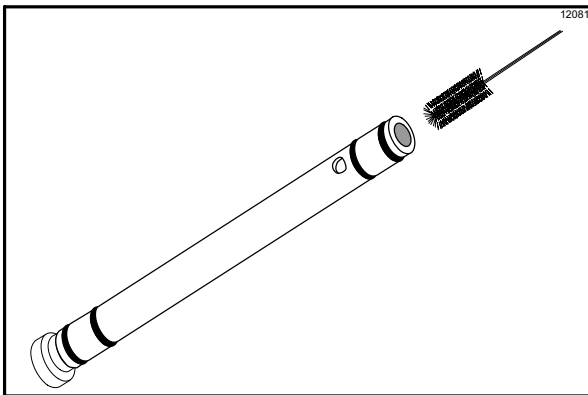



Figure 6-33

4. Place the power switch in the ON position.

5. Press the Wash key  and allow the sanitizing solution in the freezing cylinder to agitate for 5 minutes.
6. With a pail beneath the door spout(s), open and close the draw valve six times. Then open the draw valve and draw off the sanitizing solution.

7. Press the Wash key  and close the draw valve.

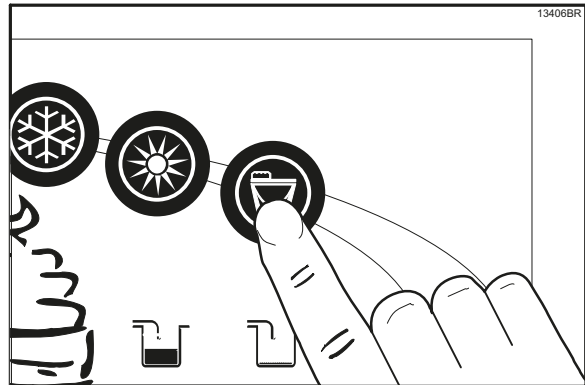

Figure 6-34

Important! The machine must **not** be placed in **Auto mode until all sanitizing solution has been removed** from the freezing cylinder and proper priming procedures have been completed. Failure to follow this instruction may result in damage to the freezing cylinder.

Note: Make sure your hands are clean and sanitized before continuing these instructions.

Note: Make sure the hole in the air orifice is clean and is not clogged. If the hole in the air orifice should become clogged, use soap and hot water to clear the hole. **Do not enlarge the hole in the air orifice.**

8. Lubricate the mix feed tube O-rings located on the end of the tube with the mix delivery hole on the side. **Do not** lubricate the O-ring on the air orifice.
9. Stand the feed tube in the corner of the mix hopper and place the agitator on the agitator housing.

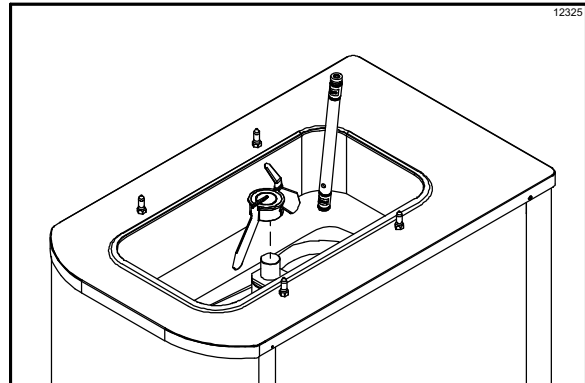

Figure 6-35

- Return to the machine with a small amount of sanitizing solution. Dip the door spout brush into the sanitizing solution and brush-clean the door spout and bottom of the draw valve.

Note: To ensure sanitary conditions are maintained, brush-clean each item for a total of 60 seconds, repeatedly dipping the brush in sanitizing solution.

- Repeat steps 1 through 10 for the other side of the C717.

Priming

Note: Use only **fresh** mix when priming the freezer.

- With a pail beneath the door spout(s), open the draw valve. Pour 2-1/2 gal. (9.5 L) of **fresh** mix into the mix hopper and allow it to flow into the freezing cylinder. This will force out any remaining sanitizing solution. When full-strength mix is flowing from the door spout, close the draw valve.

Important! Failure to remove all sanitizing solution may result in damage to the freezing cylinder.

- When mix stops bubbling down into the freezing cylinder, install the mix feed tube (end with the mix delivery hole in its side) in the mix inlet hole in the mix hopper.

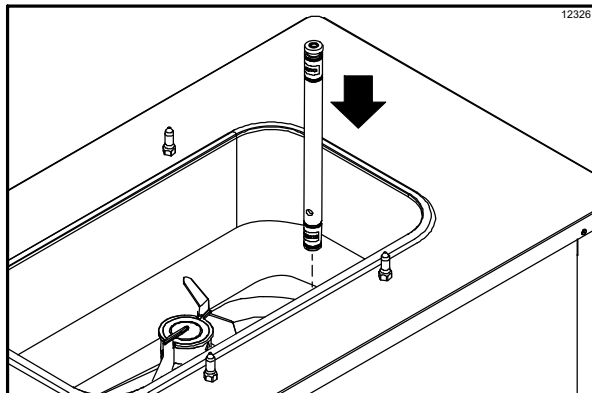



Figure 6-36

- Select the Auto key .
- Fill the hopper with **fresh** mix and place the mix hopper cover in position.
- Repeat steps 1 through 4 for the other side of the C717.

Daily Closing Procedures



Important! This procedure must be performed once daily.

The function of the Heat Treatment cycle is to destroy bacteria by raising the temperature of the mix in the freezing cylinder and hopper to a specified temperature for a specified period of time, and then bringing the temperature back down low enough to retard spoilage.

The Heat Treatment cycle will start at the time designated in the Auto Heat time.

Important! The level of mix in the mix hopper(s) must be up to the fill line on the agitator paddle(s). (The MIX LOW light must not be on.)

Note: If the BRUSH CLEAN COUNTER display has counted down to one day, do not add mix. The machine must be disassembled and brush-cleaned within 24 hours.

The machine must be in the Auto mode (Auto key  illuminated) or in the Standby mode (Standby key  illuminated) before the Heat cycle may be started.

- Remove the hopper cover(s), drip pan(s), front drip tray, and splash shield. Take them to the three-compartment sink for cleaning and sanitizing.

Important! Make sure your hands are clean and sanitized before performing these next steps.

- Remove the air orifice(s), the feed tube(s), and the agitator(s) from the mix hopper(s). Take these parts to the sink for cleaning and sanitizing.
- Rinse the parts in cool, clean water.
- Prepare a small amount of a Taylor-approved cleaning/sanitizing solution with an active chlorine concentrate of 100 PPM to 200 PPM.

Important! Use warm water and follow the cleaning/sanitizing solution manufacturer's specifications.

- Brush-clean the parts in this solution.
- Place the front drip tray, splash shield, and air orifice(s) on a clean, dry surface to air-dry overnight or until the Heating cycle is complete.

OPERATING PROCEDURES

- Prepare a small amount of a Taylor-approved cleaning/sanitizing solution with an active chlorine concentrate of 100 PPM to 200 PPM.

Important! Use warm water and follow the cleaning/sanitizing solution manufacturer's specifications.

- Sanitize the drip pan(s), feed tube(s), agitator(s), and hopper cover(s).
- Install the agitator(s) back onto the agitator drive shaft housing(s).

Important! Make sure the agitator(s) are installed and the switch is in the Auto or Standby mode, or the machine will not have a successful Heat cycle.

- Install the end of the feed tube(s) without the mix delivery hole in its side into the mix inlet hole(s). This will close the hole in the feed tube(s), preventing the mix in the hopper(s) from entering the freezing cylinder(s) during the heating and standby process.

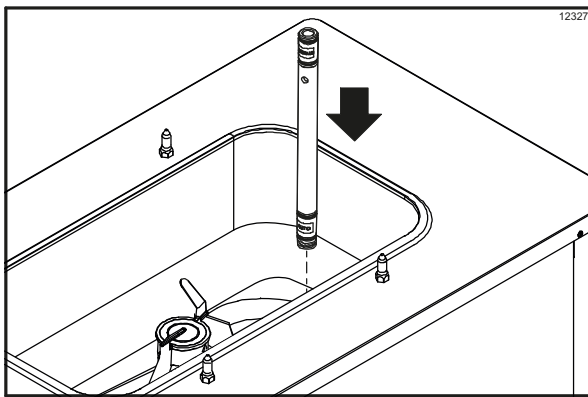

Figure 6-37

- Install the hopper cover(s) and the drip pans.
- Return to the machine with a small amount of cleaning/sanitizing solution. Dip the door spout brush into the solution and brush-clean the door spout(s) and the bottom of the draw valve(s).

Note: To ensure sanitary conditions are maintained, brush each item for 60 seconds, repeatedly dipping the brush in cleaning solution.

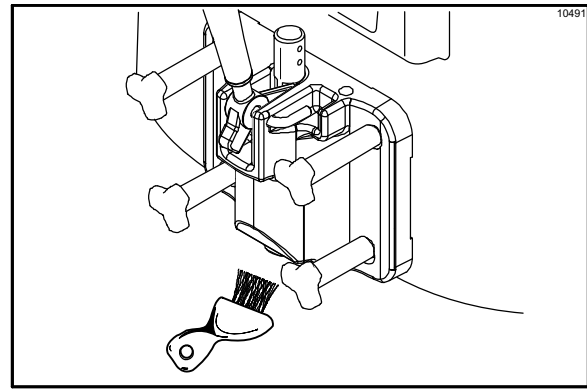



Figure 6-38



- Using a clean, sanitized towel, wipe down the freezer door, front panel, the area around the bottom of the freezer door, and any other areas with a buildup of either moisture or food substance.

The Heat cycle will start when the clock on the machine reaches the AUTO HEAT TIME set in the Manager's Menu.

There are 3 phases of the Heat cycle: heating, holding, and cooling. Each phase has a time limit. If any one of the three phases fails to reach the proper temperatures within the time limit, the cycle will automatically abort and return to the Standby mode.

A failure message will appear on the fluorescent display to inform the operator that the machine did not successfully complete the Heat Treatment cycle. The product may not be safe to serve. The machine will be locked out (soft lock) of the Auto mode. The operator will be given the option of selecting the

Heat key  which will begin a new Heat cycle or

selecting the Wash key  /  which will place the machine into the Off mode to allow a brush-clean of the machine.

Note: Once the Heat cycle has started, it cannot be interrupted. The Heat cycle will take a maximum of 6 hours to complete with full hoppers.

Important! Do not attempt to draw product or disassemble the machine during the Heat cycle. The product is hot and under extreme pressure.

When the Heating cycle is complete, the control will return to the Standby mode. The Standby key(s)

 will illuminate.

Daily Opening Procedures

Before performing the opening procedures, check the display panel for error messages. Normally, the display is blank, unless an operational fault has occurred. If a fault has been detected, investigate the cause and follow the instructions on the display before proceeding with the opening procedures. See "Faults" on page 5-13.

Setting Up

Note: Make sure your hands are clean and sanitized before performing these steps.

1. Prepare a small amount of a Taylor-approved cleaning/sanitizing solution with an active chlorine concentrate of 100 PPM to 200 PPM.

Important! Use warm water and follow the cleaning/sanitizing solution manufacturer's specifications.

2. Sanitize the air orifice(s), front drip tray, and splash shield in this solution.
3. Return to the machine with a small amount of sanitizing solution. Dip the door spout brush into the sanitizing solution and brush-clean the door spout(s) and bottom of the draw valve(s).

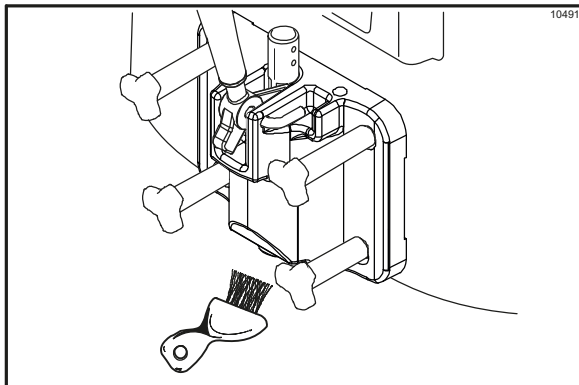



Figure 6-39

Note: To ensure sanitary conditions are maintained, brush-clean each item for 60 seconds, repeatedly dipping the brush in sanitizing solution.

4. Using a clean, sanitized towel, wipe down the freezer door, front panel, the area around the bottom of the freezer door, and any other areas with a buildup of either moisture or food substance. Install the front drip tray and the splash shield.

5. When ready to resume normal operation, press the

Auto key . When the machine cycles off, the product in the freezing cylinder will be at serving viscosity.

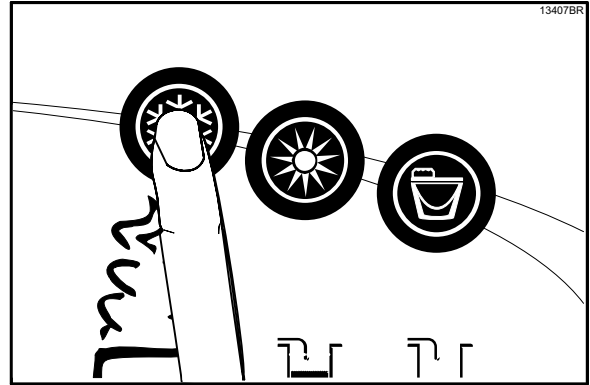

Figure 6-40

6. Lift the hopper cover(s). Invert the feed tube(s) so the end with the mix delivery hole in its side is installed in the mix inlet hole(s). Install the air orifice(s).

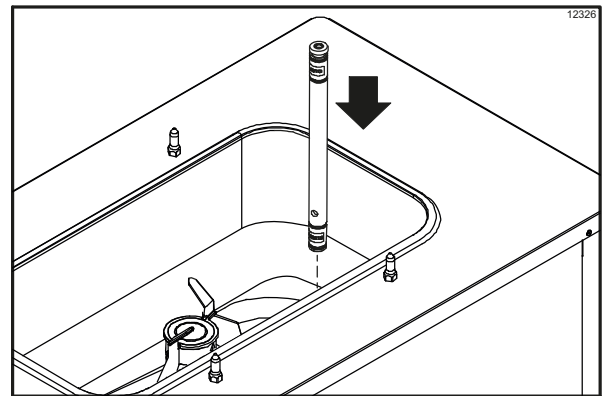

Figure 6-41

The control has a feature in the Manager's Menu to enable or disable the AUTO START feature. When AUTO START is enabled, the machine will automatically exit the Standby mode and start the machine in the Auto mode at a designated time each day.

Note: This procedure should be performed 15 minutes before serving product.

Manual Brush-Cleaning

These procedures must be completed according to the frequency specified by your federal, state, or local regulatory agencies. Please consult your governing food code to determine the maximum number of days allowed between brush-clean cycles.



ALWAYS FOLLOW LOCAL HEALTH CODES.

To disassemble and brush-clean the machine, the following items will be needed.

- Two cleaning and sanitizing pails
- Sanitizer/Cleaner
- Cleaning brushes (provided with machine)
- Single-service towels

Draining Product from the Freezing Cylinder

1. Press the Auto key  , canceling the compressor and beater motor operation.
2. Remove the hopper cover, agitator paddle, and feed tube. Take these parts to the sink for cleaning.
3. With a pail beneath the door spout(s), press the

Wash key  /  and open the draw valve.

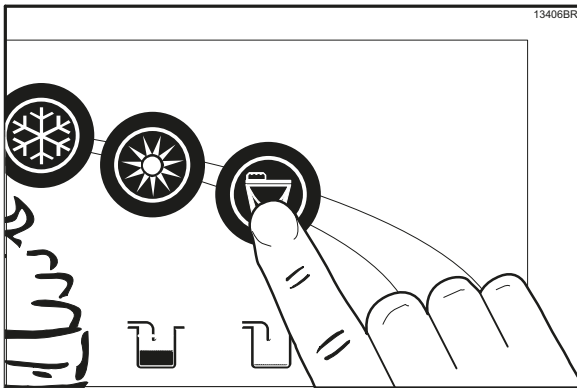

Figure 6-42

Drain the product from the freezing cylinder and mix hopper and properly dispose of the mix.

4. When the flow of product stops, press the Wash key



, canceling the Wash mode. Close the draw valve.

5. Repeat steps 1 through 4 for the other side of the C717.

Rinsing

1. Pour 2 gal. (7.6 L) of cool, clean water into the mix hopper. With the white hopper brush, scrub the mix hopper, mix-level sensing probes, and the outside of the agitator driveshaft housing. Using the double-ended brush, brush-clean the mix inlet hole.

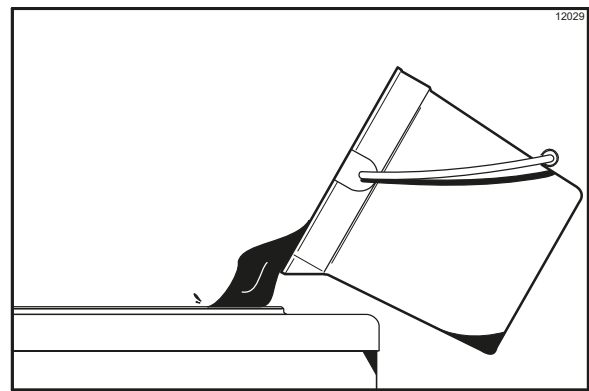

Figure 6-43

Note: Do not brush-clean the mix inlet hole while the machine is in the Wash mode.

2. With a pail beneath the door spout(s), press the

Wash key  /  .

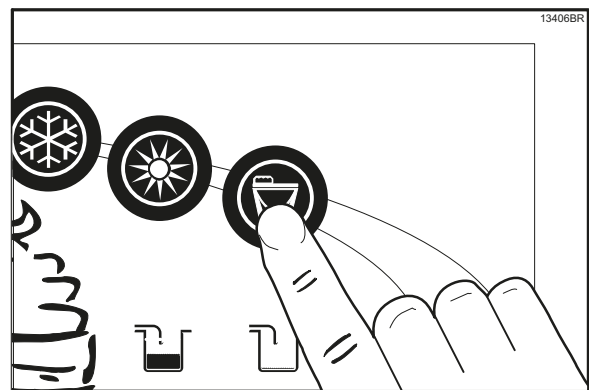



Figure 6-44

- Open the draw valve on the freezer door. Drain all the rinse water from the door spout. Close the draw

valve, and press the Wash key,  /  canceling the Wash mode.

- Repeat this procedure using clean, warm water, until the water being discharged is clear.
- Repeat steps 1 through 4** for the other side of the C717.



Hopper Cleaning



- Prepare a 2-1/2 gal. (9.5 L) pail of a Taylor-approved cleaning/sanitizing solution with an active chlorine concentrate of 100 PPM to 200 PPM.

Important! Use warm water and follow the cleaning/sanitizing solution manufacturer's specifications.

- Pour the solution into the hopper and allow it to flow into the freezing cylinder.
- Using the white hopper brush, clean the mix hopper, mix-level sensing probes, and the outside of the agitator driveshaft housing. Using the double-ended brush, clean the mix inlet hole.

Note: Do not brush-clean the mix inlet hole while the machine is in the Wash mode.

- Press the Wash key  /  . The cleaning solution in the freezing cylinder will contact all areas of the freezing cylinder.
- Place an empty pail beneath the door spout(s).
- Open the draw valve on the freezer door and draw off all the solution.
- Once the cleaning solution stops flowing from the door spout, close the draw valve and press the

Wash key  /  , canceling the Wash mode.

- Repeat steps 1 through 7** for the other side of the C717.

Disassembly

Note: Failure to remove the parts specified below for brush-cleaning and lubrication will result in damage to the machine. These parts must be removed within the maximum number of days allowed between brush-clean cycles, or the machine will hard lock and will not operate.



WARNING! Make sure the power switch is in the OFF position! Failure to follow this instruction may result in severe personal injury to fingers or hands from hazardous moving parts.

- Remove the handscrews, freezer door, beater, scraper blades, and driveshaft with driveshaft seal from the freezing cylinder.
- Remove the scraper blades.
- Remove the driveshaft seal from the driveshaft.
- Remove the freezer door gasket(s), front bearing(s), pivot pin(s), draw handle(s), and draw valve(s). Remove the three O-rings from the draw valve(s).
- Model C717:** Remove the design caps.
- Remove the front drip tray and splash shield.
- Remove all drip pans and take them to the sink for cleaning.

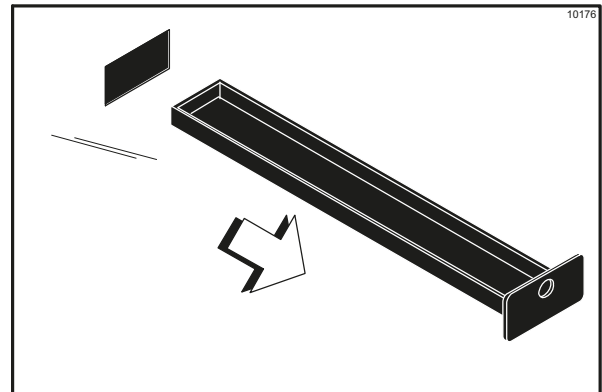

Figure 6-45

Note: If the drip pans are filled with an excessive amount of mix, the driveshaft seal(s) or O-ring(s) should be replaced or properly lubricated.

- Repeat steps 1 through 7** for the other side of the C717.

Brush-Cleaning

1. Prepare a sink of Taylor-approved cleaning/sanitizing solution with an active chlorine concentrate of 100 PPM to 200 PPM.

Important! Use warm water and follow the cleaning/sanitizing solution manufacturer's specifications. Make sure all brushes provided with the machine are available for brush cleaning.

2. Remove all O-rings.
3. Thoroughly brush-clean all disassembled parts in the cleaning solution, making sure all lubricant and mix film is removed. Make sure to brush all surfaces and holes, especially the draw valve hole in the freezer door.
4. Rinse all parts with clean, warm water. Place the parts on a clean, dry surface to air-dry overnight.

5. Return to the machine with a small amount of cleaning solution. Using the black brush, clean the rear shell bearing at the back of the freezing cylinder.

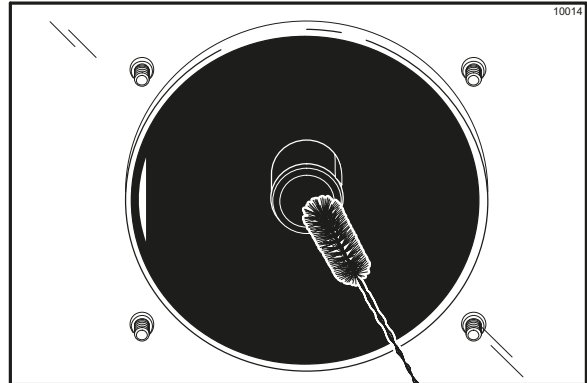

Figure 6-46

6. Repeat steps 1 through 5 for the other side of the C717.
7. Wipe all exterior surfaces of the machine with a clean, sanitized towel.

During Brush-Cleaning and Sanitizing



ALWAYS FOLLOW LOCAL HEALTH CODES.



NOTICE! Cleaning and sanitizing schedules are governed by your federal, state, or local regulatory agencies and must be followed accordingly. Please refer to the cleaning section of this manual for the proper procedure to clean this machine.

Please consult your governing food code to determine the maximum number of days allowed between brush-clean cycles.

The following checkpoints should be stressed during the cleaning and sanitizing operations.

Troubleshooting Bacterial Count

- Thoroughly clean and sanitize the machine regularly, including complete disassembly and brush-cleaning.
- Use all brushes supplied for thorough cleaning. The brushes are specially designed to reach all mix passageways.
- Use the white bristle brush to clean the mix inlet hole, which extends from the mix hopper down to the rear of the freezing cylinder.
- Use the black bristle brush to thoroughly clean the rear shell bearing located at the rear of the freezing cylinder. Use a generous amount of cleaning solution on the brush.
- Properly prepare the cleaning and sanitizing solutions. Read and follow the label directions carefully. Too **strong** of a solution may damage the parts, and too **weak** of a solution will not do an adequate job of cleaning or sanitizing.
- The temperature of the mix in the mix hopper and walk-in cooler should be below 40°F (4.4°C).

Regular Maintenance Checks

- Replace scraper blades that are nicked or damaged. Before installing the beater assembly, make sure the scraper blades are properly attached to the beater assembly.
- Check the rear shell bearing for signs of wear (excessive mix leakage in rear drip pan) and make sure it is properly cleaned.
- Using a screwdriver and cloth towel, clean the rear shell bearing and the female hex drive socket of lubricant and mix deposits.
- Dispose of O-rings and seals if they are worn, torn, or fit too loosely, and replace them with new ones.
- Follow all lubricating procedures as outlined in the "Assembly" section on page 6-1.



WARNING! Always disconnect electrical power prior to cleaning the condenser. Failure to follow this instruction may result in electrocution.

- If your machine is air-cooled or equipped with an auxiliary refrigeration system, check the condensers for dirt and lint accumulation. Dirty condensers will reduce the efficiency and capacity of the machine. Condensers should be cleaned at least once a month with a soft brush. **Never** use screwdrivers or other metal probes to clean between the fins.
- If your machine is water-cooled, check the water lines for kinks or leaks. Kinks can occur when the machine is moved back and forth for cleaning or maintenance purposes. Deteriorated or cracked water lines should only be replaced by an authorized Taylor service technician.

Winter Storage

If the place of business is to be closed during the winter months or for any extended period of time, it is important to protect the machine by following certain precautions, particularly if the building is subject to freezing conditions.

Disconnect the machine from the main power source to prevent possible electrical damage.

On water-cooled machines, disconnect the water supply. Relieve pressure on the spring in the water valve. Use air pressure on the outlet side to blow out any water remaining in the condenser.

Important! *Failure to follow this procedure may cause severe and costly damage to the machine.*

Your local Taylor distributor can perform this winter storage service for you.

Wrap detachable parts of the machine including but not limited to the beater, blades, driveshaft, and freezer door, and place those parts in a protected dry place. Rubber trim parts and gaskets can be protected by wrapping them with moisture-proof paper. Before such storage, all parts should be thoroughly cleaned of dried mix or lubrication, which can attract mice and other vermin.

It is recommended that a Taylor service technician perform winter storage draining to make sure all water has been removed. This will guard against freezing and rupturing of the components.

Table 8-1

Problem	Probable Cause	Remedy	Page Ref.
<p>1. Soft lock message appears on display.</p>	<p>a. More than 24 hours since the last Heat cycle.</p>	<p>a. The freezer must go through a Heat cycle every 24 hours. The freezer must now be disassembled and brush-cleaned or placed in a Heat cycle.</p>	<p>5-8</p>
	<p>b. The power switch is in the OFF position.</p>	<p>b. The power switch must be in the ON position. The freezer must now be disassembled and brush-cleaned or placed in a Heat cycle.</p>	<p>5-9</p>
	<p>c. The machine was not in the Auto or Standby mode when the Heat cycle was programmed to start.</p>	<p>c. The freezer must be in the Auto or Standby mode. The freezer must now be disassembled and brush-cleaned or placed in a Heat cycle.</p>	<p>5-9</p>
	<p>d. Mix Out condition.</p>	<p>d. Level of mix in hopper must be up to the fill line on the agitator paddle. The freezer must now be disassembled and brush-cleaned or placed in a Heat cycle.</p>	<p>5-9</p>
	<p>e. The agitator is not installed.</p>	<p>e. The agitator must be cleaned and installed before starting the Heat cycle. The freezer must now be disassembled and brush-cleaned or placed in a Heat cycle.</p>	<p>6-9</p>
	<p>f. There was a power failure.</p>	<p>f. Check fault messages and product temperature. Disassemble and brush-clean or initiate a Heat Treatment cycle.</p>	<p>5-14</p>
<p>2. Hard lock message appears on display.</p>	<p>a. Brush-clean interval was exceeded.</p>	<p>a. The freezer must be disassembled and brush-cleaned within 24 hours when the counter indicates one day remaining.</p>	<p>5-7</p>
	<p>b. A barrel or hopper thermistor is faulty.</p>	<p>b. Call a Taylor service technician.</p>	<p>---</p>

TROUBLESHOOTING GUIDE

Problem	Probable Cause	Remedy	Page Ref.
3. No product is being dispensed.	a. Low on mix. The MIX OUT light is on.	a. Add mix to the mix hopper. Return to Auto mode.	5-2
	b. The power switch is in the OFF position.	c. Place the power switch to ON and select Auto mode.	6-11
	c. The circuit breaker is off or the fuse is blown.	d. Turn the breaker on or replace the fuse.	---
	d. Beater motor is out on reset, BEATER OVERLOAD message displayed.	e. Turn the machine off. Press the RESET button. Restart the machine in Auto mode.	---
	e. Machine is not in Auto mode.	f. Select Auto mode and allow machine to cycle off before drawing product.	6-11
	f. Feed tube not properly installed.	g. Make sure the feed tube is properly installed.	6-11
	g. Freeze-up in mix inlet hole.	h. Call a Taylor service technician.	---
	h. The beater is rotating counterclockwise when observed from the operator end.	i. Contact a Taylor service technician to correct rotation.	1-3
	4. The product is too soft.	a. Draw rate is set too fast.	a. Adjust draw rate of 5 oz. to 7 1/2 oz. (142 g to 213 g) of product by weight in 10 seconds.
b. Not enough airspace around machine. (Air-cooled machines).		b. Allow for adequate airflow across the condenser.	1-2
c. Worn scraper blades.		c. Replace regularly.	9-1
d. Dirty condenser (A/C).		d. Clean monthly.	7-1
e. Mix is out of date.		e. Use only fresh mix.	---
f. Loss of water (W/C).		f. Locate cause of water loss and correct.	7-2
g. Viscosity needs adjustment.		g. Contact a Taylor service technician.	---
5. The product is too thick.	a. Freezing cylinder not primed correctly.	a. Drain the freezing cylinder and reprime the machine.	6-9
	b. The viscosity control is set too cold.	b. Call a Taylor service technician.	---
	c. Freeze-up in mix inlet hole.	c. Call a Taylor service technician.	---
6. The mix in the hopper is too warm.	a. Hopper cover is not in position.	a. Clean and sanitize the hopper cover and place in position.	6-9
	b. The agitator is not installed.	b. Clean and sanitize the agitator and install.	6-11
	c. The hopper temperature is out of adjustment.	c. Call a Taylor service technician.	---
7. The mix in the hopper is too cold.	a. The hopper temperature is out of adjustment.	a. Call a Taylor service technician.	---
8. Mix Low and Mix Out probes are not functioning.	a. Milkstone buildup in the hopper.	a. Clean hopper(s) thoroughly.	6-13
9. Product is collecting on top of the freezer door.	a. The top O-ring on the draw valve is improperly lubricated or worn.	a. Lubricate properly or replace the O-ring.	6-5

Problem	Probable Cause	Remedy	Page Ref.
10. Excessive mix leakage from door spout.	a. Missing or worn draw valve O-rings.	a. Install or replace regularly.	6-5
	b. Inadequate lubrication of draw valve O-rings.	b. Lubricate properly.	6-5
	c. Wrong type of lubricant is being used (example: petroleum-based lubricant).	c. Use the proper lubricant (example: Taylor Lube HP).	4-8
11. Excessive mix leakage into the rear drip pan.	a. Missing or worn seal on driveshaft.	a. Install or replace regularly.	6-1
	b. The driveshaft seal is installed inside out.	b. Install correctly.	6-1
	c. Improper lubrication of driveshaft and/or seal.	c. Lubricate properly.	6-2
	d. The driveshaft and beater assembly worked forward.	d. Call a Taylor service technician.	---
	e. Worn rear shell bearing.	e. Call a Taylor service technician.	---
	f. Gearbox out of alignment.	f. Call a Taylor service technician.	---
12. The driveshaft is stuck in the drive coupling.	a. Mix and lubricant collected in drive coupling.	a. Brush-clean the rear shell bearing area regularly.	7-1
	b. Rounded corners of driveshaft, drive coupling, or both.	b. Call a Taylor service technician.	---
	c. Gearbox is out of alignment.	c. Call a Taylor service technician.	---
13. The freezing cylinder walls are scored.	a. Missing or worn front bearing and beater shoes.	a. Install or replace the front bearing and beater shoes	6-3
	b. Scraper blades are damaged.	b. Replace scraper blades.	6-3
	c. Machine was placed in Auto mode before all sanitizing solution was removed from freezing cylinder.	c. Place machine in Auto mode only after priming is complete and all sanitizing solution is removed.	6-9
	d. The baffle rod on the freezer door is broken.	d. Replace freezer door.	6-3
	e. Beater assembly is bent.	e. Replace beater assembly.	6-1
	f. Gearbox is out of alignment.	f. Call a Taylor service technician.	---
14. The product makes a popping sound when drawn.	a. Draw rate is set too fast.	a. Adjust draw rate of 5 oz. to 7 1/2 oz. (142 g to 213 g) of product by weight in 10 seconds.	6-6
	b. Freezing cylinder not primed correctly.	b. Drain the freezing cylinder and reprime the machine.	6-9
15. No control panel functions with power switch in ON position.	a. Machine is unplugged.	a. Plug into wall receptacle.	---
	b. Circuit breaker off or blown fuse.	b. Turn the breaker on or replace the fuse.	---
16. No freezer operation after pressing the AUTO key.	a. Machine is unplugged.	a. Plug into wall receptacle.	---
	b. The circuit breaker is off or the fuse is blown.	b. Turn the breaker on or replace the fuse.	---
	c. The beater motor is out on reset.	c. Reset the machine.	5-3
17. Too much pressure in the freezing cylinder.	a. Inadequate level of mix in the mix hopper.	a. Fill the mix hopper with mix.	6-11
	b. The mix inlet hole is frozen up.	b. The mix hopper temperature needs adjustment. Call a Taylor service technician.	---

Table 9-1

Part Description	Every 3 Months	Every 6 Months	Annually
Scrapers Blades	X		
Driveshaft Seal	X		
Freezer Door Gasket	X		
Front Bearing	X		
Draw Valve O-ring	X		
Mix Feed Tube O-ring	X		
Air Orifice O-ring	X		
White Bristle Brush, 3" x 7"			
White Bristle Brush, 1" x 2"		Inspect and replace if necessary.	Minimum
White Bristle Brush, 1" x 2"		Inspect and replace if necessary.	Minimum
Black Bristle Brush, 1" x 2"		Inspect and replace if necessary.	Minimum
Double-Ended Brush		Inspect and replace if necessary.	Minimum
Yellow Bristle Brush		Inspect and replace if necessary.	Minimum

TAYLOR COMPANY LIMITED WARRANTY ON FREEZERS

Taylor Company is pleased to provide this limited warranty on new Taylor-branded freezer equipment available from Taylor to the market generally (the "Product") to the original purchaser only.

LIMITED WARRANTY

Taylor warrants the Product against failure due to defect in materials or workmanship under normal use and service as follows. All warranty periods begin on the date of original Product installation. If a part fails due to defect during the applicable warranty period, Taylor, through an authorized Taylor distributor or service agency, will provide a new or remanufactured part, at Taylor's option, to replace the failed defective part at no charge for the part. Except as otherwise stated herein, these are Taylor's exclusive obligations under this limited warranty for a Product failure. This limited warranty is subject to all provisions, conditions, limitations, and exclusions listed below and on the reverse (if any) of this document.

Table 10-1

Product	Part	Limited Warranty Period
Soft Serve	Insulated shell assembly	Five (5) years
Frozen Yogurt	Refrigeration compressor (except service valve)	Five (5) years
Shakes	Beater motors	Two (2) years
Smoothies	Beater drive gear	Two (2) years
Frozen Beverage	Printed circuit boards and Softech controls beginning with serial number H8024200	Two (2) years
Batch Desserts	Parts not otherwise listed in this table or excluded below	One (1) years

LIMITED WARRANTY CONDITIONS

1. If the date of original installation of the Product cannot be verified, then the limited warranty period begins ninety (90) days from the date of Product manufacture (as indicated by the Product serial number). Proof of purchase may be required at time of service.
2. This limited warranty is valid only if the Product is installed and all required service work on the Product is performed by an authorized Taylor distributor or service agency, and only if genuine, new Taylor parts are used.
3. Installation, use, care, and maintenance must be normal and in accordance with all instructions contained in the Taylor Operator's Manual.
4. Defective parts must be returned to the authorized Taylor distributor or service agency for credit.
5. The use of any refrigerant other than that specified on the Product's data label will void this limited warranty.

LIMITED WARRANTY ON EQUIPMENT

LIMITED WARRANTY EXCEPTIONS

This limited warranty does **not** cover:

1. Labor or other costs incurred for diagnosing, repairing, removing, installing, shipping, servicing, or handling of defective parts, replacement parts, or new Products.
2. Normal maintenance, cleaning, and lubrication as outlined in the Taylor Operator's Manual, including cleaning of condensers.
3. Replacement of wear items designated as Class "000" parts in the Taylor Operator's Manual.
4. External hoses, electrical power supplies, and machine grounding.
5. Parts not supplied or designated by Taylor, or damages resulting from their use.
6. Return trips or waiting time required because a service technician is prevented from beginning warranty service work promptly upon arrival.
7. Failure, damage, or repairs due to faulty installation, misapplication, abuse, no or improper servicing, unauthorized alteration, or improper operation or use as indicated in the Taylor Operator's Manual, including but not limited to the failure to use proper assembly and cleaning techniques, tools, or approved cleaning supplies.
8. Failure, damage, or repairs due to theft, vandalism, wind, rain, flood, high water, water, lightning, earthquake, or any other natural disaster, fire, corrosive environments, insect or rodent infestation, or other casualty, accident, or condition beyond the reasonable control of Taylor; operation above or below the electrical, or water supply specification of the Product; or components repaired or altered in any way so as, in the judgment of the Manufacturer, to adversely affect performance, or normal wear or deterioration.
9. Any Product purchased over the Internet.
10. Failure to start due to voltage conditions, blown fuses, open circuit breakers, or damages due to the inadequacy or interruption of electrical service.
11. Electricity or fuel costs, or increases in electricity or fuel costs from any reason whatsoever.
12. Damages resulting from the use of any refrigerant other than that specified on the Product's data label will void this limited warranty.
13. Any cost to replace, refill, or dispose of refrigerant, including the cost of refrigerant.
14. **ANY SPECIAL, INDIRECT, OR CONSEQUENTIAL PROPERTY OR COMMERCIAL DAMAGE OF ANY NATURE WHATSOEVER.** Some jurisdictions do not allow the exclusion of incidental or consequential damages, so this limitation may not apply to you.

This limited warranty gives you specific legal rights, and you may also have other rights which vary from jurisdiction to jurisdiction.

LIMITATION OF WARRANTY

THIS LIMITED WARRANTY IS EXCLUSIVE AND IS IN LIEU OF ALL OTHER WARRANTIES, CONDITIONS, AND/OR REMEDIES UNDER THE LAW, INCLUDING ANY IMPLIED WARRANTIES OR CONDITIONS OF MERCHANTABILITY OR FITNESS FOR A PARTICULAR PURPOSE. THE ORIGINAL OWNER'S SOLE REMEDY WITH RESPECT TO ANY PRODUCTS SHALL BE REPAIR OR REPLACEMENT OF DEFECTIVE COMPONENTS UNDER THE TERMS OF THIS LIMITED WARRANTY. ALL RIGHTS TO CONSEQUENTIAL OR INCIDENTAL DAMAGES (INCLUDING CLAIMS FOR LOST SALES, LOST PROFITS, PRODUCT LOSS, PROPERTY DAMAGES, OR SERVICE EXPENSES) ARE EXPRESSLY EXCLUDED. THE EXPRESS WARRANTIES MADE IN THIS LIMITED WARRANTY MAY NOT BE ALTERED, ENLARGED, OR CHANGED BY ANY DISTRIBUTOR, DEALER, OR OTHER PERSON, WHATSOEVER.

LEGAL REMEDIES

The owner **must** notify Taylor in writing, by certified or registered letter to the following address, of any defect or complaint with the Product, stating the defect or complaint and a specific request for repair, replacement, or other correction of the Product under warranty, mailed at least thirty (30) days before pursuing any legal rights or remedies.

Taylor Company
750 N. Blackhawk Blvd.
Rockton, IL 61072, U.S.A.

TAYLOR COMPANY LIMITED WARRANTY ON TAYLOR GENUINE PARTS

Taylor Company is pleased to provide this limited warranty on new Taylor genuine replacement components and parts available from Taylor to the market generally (the "Parts") to the original purchaser only.

LIMITED WARRANTY

Taylor warrants the Parts against failure due to defect in materials or workmanship under normal use and service as follows. All warranty periods begin on the date of original installation of the Part in the Taylor unit. If a Part fails due to defect during the applicable warranty period, Taylor, through an authorized Taylor distributor or service agency, will provide a new or remanufactured Part, at Taylor's option, to replace the failed defective Part at no charge for the Part. Except as otherwise stated herein, these are Taylor's exclusive obligations under this limited warranty for a Part failure. This limited warranty is subject to all provisions, conditions, limitations, and exclusions listed below and on the reverse (if any) of this document.

Table 11-1

Parts Warranty Class Code Or Part	Limited Warranty Period
Class 103 Parts ¹	Three (3) Months
Class 212 Parts ²	Twelve (12) Months
Class 512 Parts	Twelve (12) Months
Class 000 Parts	No Warranty

LIMITED WARRANTY CONDITIONS

1. If the date of original installation of the Part cannot be otherwise verified, proof of purchase may be required at time of service.
2. This limited warranty is valid only if the Part is installed and all required service work in connection with the Part is performed by an authorized Taylor distributor or service agency.
3. The limited warranty applies only to Parts remaining in use by their original owner at their original installation location in the unit of original installation.
4. Installation, use, care, and maintenance must be normal and in accordance with all instructions contained in the Taylor Operator's Manual.
5. Defective Parts must be returned to the authorized Taylor distributor or service agency for credit.
6. This warranty is not intended to shorten the length of any warranty coverage provided pursuant to a separate Taylor Limited Warranty on freezer or grill equipment.
7. The use of any refrigerant other than that specified for the unit in which the Part is installed will void this limited warranty.

^{1, 2} Except that Taylor Part #032129SER2 (Compressor-Air-230V SERV) and Taylor Part #075506SER1 (Compressor-Air-115V 60HZ) shall have a limited warranty period of twelve (12) months when used in Taylor freezer equipment and a limited warranty period of two (2) years when used in Taylor grill equipment.

LIMITED WARRANTY ON PARTS

LIMITED WARRANTY EXCEPTIONS

This limited warranty does **not** cover:

1. Labor or other costs incurred for diagnosing, repairing, removing, installing, shipping, servicing, or handling of defective Parts, replacement Parts, or new Parts.
2. Normal maintenance, cleaning, and lubrication as outlined in the Taylor Operator's Manual, including cleaning of condensers or carbon and grease buildup.
3. Required service, whether cleaning or general repairs, to return the cooking surface assemblies, including the upper platen and lower plate, to an operational condition to achieve proper cooking or allow proper assembly of release sheets and clips as a result of grease buildup on the cooking surfaces, including but not limited to the platen and plate, sides of the shroud, or top of the shroud.
4. Replacement of cooking surfaces, including the upper platen and lower plate, due to pitting or corrosion (or in the case of the upper platen, due to loss of plating) as a result of damage due to the impact of spatulas or other small wares used during the cooking process or as a result of the use of cleaners, cleaning materials, or cleaning processes not approved for use by Taylor.
5. Replacement of wear items designated as Class "000" Parts in the Taylor Operator's Manual, as well as any release sheets and clips for the Product's upper platen assembly.
6. External hoses, electrical power supplies, and machine grounding.
7. Parts not supplied or designated by Taylor, or damages resulting from their use.
8. Return trips or waiting time required because a service technician is prevented from beginning warranty service work promptly upon arrival.
9. Failure, damage, or repairs due to faulty installation, misapplication, abuse, no or improper servicing, unauthorized alteration, or improper operation or use as indicated in the Taylor Operator's Manual, including but not limited to the failure to use proper assembly and cleaning techniques, tools, or approved cleaning supplies.
10. Failure, damage, or repairs due to theft, vandalism, wind, rain, flood, high water, water, lightning, earthquake, or any other natural disaster, fire, corrosive environments, insect or rodent infestation, or other casualty, accident or condition beyond the reasonable control of Taylor; operation above or below the gas, electrical, or water supply specification of the unit in which a part is installed; or Parts or the units in which they are installed, repaired, or altered in any way so as, in the judgment of Taylor, to adversely affect performance, or normal wear or deterioration.
11. Any Part purchased over the Internet.
12. Failure to start due to voltage conditions, blown fuses, open circuit breakers, or damages due to the inadequacy or interruption of electrical service.
13. Electricity, gas, or other fuel costs, or increases in electricity or fuel costs from any reason whatsoever.
14. Damages resulting from the use of any refrigerant other than that specified for the unit in which the Part is installed will void this limited warranty.
15. Any cost to replace, refill, or dispose of refrigerant, including the cost of refrigerant.
16. **ANY SPECIAL, INDIRECT, OR CONSEQUENTIAL PROPERTY OR COMMERCIAL DAMAGE OF ANY NATURE WHATSOEVER.** Some jurisdictions do not allow the exclusion of incidental or consequential damages, so this limitation may not apply to you.

This limited warranty gives you specific legal rights, and you may also have other rights which vary from jurisdiction to jurisdiction.

LIMITATION OF WARRANTY

THIS LIMITED WARRANTY IS EXCLUSIVE AND IS IN LIEU OF ALL OTHER WARRANTIES, CONDITIONS, AND/OR REMEDIES UNDER THE LAW, INCLUDING ANY IMPLIED WARRANTIES OR CONDITIONS OF MERCHANTABILITY OR FITNESS FOR A PARTICULAR PURPOSE. THE ORIGINAL OWNER'S SOLE REMEDY WITH RESPECT TO ANY PRODUCTS SHALL BE REPAIR OR REPLACEMENT OF DEFECTIVE PARTS UNDER THE TERMS OF THIS LIMITED WARRANTY. ALL RIGHTS TO CONSEQUENTIAL OR INCIDENTAL DAMAGES (INCLUDING CLAIMS FOR LOST SALES, LOST PROFITS, PRODUCT LOSS, PROPERTY DAMAGES, OR SERVICE EXPENSES) ARE EXPRESSLY EXCLUDED. THE EXPRESS WARRANTIES MADE IN THIS LIMITED WARRANTY MAY NOT BE ALTERED, ENLARGED, OR CHANGED BY ANY DISTRIBUTOR, DEALER, OR OTHER PERSON, WHATSOEVER.

LEGAL REMEDIES

The owner **must** notify Taylor in writing, by certified or registered letter to the following address, of any defect or complaint with the Part, stating the defect or complaint and a specific request for repair, replacement, or other correction of the Part under warranty, mailed at least thirty (30) days before pursuing any legal rights or remedies.

Taylor Company
750 N. Blackhawk Blvd.
Rockton, IL 61072, U.S.A.

