

TURBOCHEF™

OWNER'S MANUAL

BULLET



TABLE OF CONTENTS

- 1. REVISION HISTORY 7
- 2. IMPORTANT SAFETY INSTRUCTIONS 8
 - 2.1 General Safety Information 8
 - 2.2 Reducing Fire Risk 9
 - 2.3 Grounding Instructions 9
 - 2.4 Power Cord Replacement 9
 - 2.5 Excessive Microwave Energy Precautions 10
 - 2.6 RF Interference Considerations 10
 - 2.7 Protective Earth (Ground) Symbol 10
 - 2.8 Equipotential Bonding Symbol 10
- 3. SPECIFICATIONS 11
 - 3.1 Theory of Operation 11
 - 3.2 Features 11
 - 3.3 Dimensions 11
 - 3.4 Certifications 12
 - 3.5 Oven Construction 12
 - 3.6 Electrical Specifications 12
- 4. INSTALLATION 13
 - 4.1 Unpacking Instructions 13
 - 4.2 Oven Installation 13
 - 4.1 Oven Restraint Kit 14
 - 4.2 Installation Near Open Heat Source 14
 - 4.3 ChefComm One Touch 14
 - 4.4 Open Kitchen 14
 - 4.5 ConnectWare 15
 - 4.6 Voltage Selection 15
 - 4.7 Ventilation 15

- 5. CLEANING 16
 - 5.1 Daily Maintenance 16
 - 5.2 Supplies and Equipment 16
 - 5.3 Quarterly Maintenance 19
 - 5.4 Supplies and Equipment 19
- 6. ONETOUCH CONTROLLER OPERATION 21
 - 6.1 Recipe Mode 22
 - 6.2 Manual Cook Mode 24
 - 6.3 Settings Mode 24
 - 6.3.1 Oven Settings 25
 - 6.4 Edit Mode 26
 - 6.4.1 Creating a Group 26
 - 6.4.2 Editing a Group 27
 - 6.4.3 Creating a Recipe 27
 - 6.4.4 Adding a Recipe to a Group 28
 - 6.4.5 Editing a Recipe 29
 - 6.5 Load Menu from USB 29
- 7. LEGACY CONTROLLER OPERATION 30
 - 7.1 Oven Controls: Legacy 30
 - 7.2 Menu Cook Mode 31
 - 7.3 Manual Cook Mode 33
 - 7.4 Info Mode 34
 - 7.4.1 Information Screen 34
 - 7.4.2 Counters Screen 34
 - 7.4.3 Options Screen 35
 - 7.5 Settings Screen 36
 - 7.5.1 Temperature (F/C) 36
 - 7.5.2 Language 36

- 7.5.3 Wi-Fi/Network..... 36
- 7.5.4 Sound Volume 36
- 7.5.5 Set Date..... 36
- 7.5.6 Set Time..... 36
- 7.5.7 Auto On 37
- 7.5.8 Auto Off..... 37
- 7.6 Edit Mode..... 37
 - 7.6.1 Edit Set Temperature..... 37
 - 7.6.2 Edit Bottom Temperature Offset 38
 - 7.6.3 Name a Group..... 38
 - 7.6.4 Delete a Group 39
 - 7.6.5 Move a Group..... 39
- 7.7 Edit Item Settings..... 39
 - 7.7.1 Name an Item 41
 - 7.7.2 Change Group..... 41
 - 7.7.3 Move an Item 41
 - 7.7.4 Delete an Item..... 42
- 7.8 Load Menu from USB 42
- 7.9 Save Menu to USB 43
- 8. TROUBLESHOOTING 44
- 9. NORTH AMERICA LIMITED WARRANTY..... 47
 - 9.1 Limited Warranty 47
 - 9.2 Disclaimer..... 47
 - 9.3 Warranty Exclusions..... 47
 - 9.4 Warranty Service, Exclusive Remedy 48
 - 9.5 Warranty Claims..... 49
 - 9.6 Disclaimer of Damages..... 49
 - 9.7 Customer Indemnity..... 49

- 9.8 Territory..... 49
- 9.9 Governing Law, Entire Warranty 49
- 9.10 Charges for Non-Warranty Service or Rejection of Service Visit 50
- 10. INTERNATIONAL LIMITED WARRANTY 51
 - 10.1 Limited Warranty 51
 - 10.2 Disclaimer 51
 - 10.3 The TurboChef Global Warranty System..... 51
 - 10.4 Warranty Service 52

For further information, call

800.90TURBO

or

+1 214.379.6000

1. REVISION HISTORY

Revision	Revision Date	By	Revision Description
A	13-Jan-26	BA	<ul style="list-style-type: none">• New template, updated version ENC-1637 Rev J• Editorial revisions and formatting updates for clarity and consistency, no technical content changed

2. IMPORTANT SAFETY INSTRUCTIONS

⚠ WARNING: When operating this oven, strictly adhere to the following safety precautions to reduce the risk of burns, electric shock, fire, injury, damage to the oven or property near the oven, or possible exposure to excessive microwave energy.

2.1 General Safety Information

- ✓ Read all instructions before using this appliance.
- ✓ Read and follow the specific [Excessive Microwave Energy Precautions](#) section.
- ✓ This appliance must be grounded. Connect only to a properly grounded outlet. Refer to the [Grounding Instructions](#) section.
- ✓ Install or locate this appliance only in accordance with the installation instructions provided.
- ✓ This appliance should be serviced by qualified service personnel only. Contact the nearest authorized service facility for examination, repair, or adjustment.
- ✓ Keep the cord away from heated surfaces.
- ✓ Liquids, such as water, coffee, or tea can be overheated beyond the boiling point without appearing to be boiling. Visible bubbling or boiling when the container is removed from the microwave oven is not always present. This could result in very hot liquid suddenly boiling over when the container is disturbed or a utensil is inserted into the liquid.
⚠ WARNING: The contents of feeding bottles and baby food jars must be stirred or shaken and the temperature checked before consumption, to avoid burns (IEC 60335-2-90).
- ✓ Use this appliance only for its intended uses as described in this manual.
- ✓ Only use utensils that are suitable for use in microwave ovens (IEC 60335-2-90).
- ✓ This appliance is not to be used by children or persons with reduced physical, sensory or mental capabilities, or lack of experience and knowledge, unless they have been given supervision or instruction.

DO NOT perform the following:

- ✗ Use corrosive chemicals or vapors in this appliance; it is not designed for industrial/laboratory use.
- ✗ Do not heat liquids or other foods in sealed containers (e.g., jars, whole eggs, etc.) since they are liable to explode.
CAUTION: Failure to maintain the oven in a clean condition could lead to deterioration of the surface that could adversely affect the life of the appliance and possibly result in hazardous situation.
- ✗ Allow children to use this appliance.
- ✗ Operate this appliance if it has a damaged cord or plug, is not working properly, or has been damaged or dropped. Refer to the [Power Cord Replacement](#) section.

- ✘ Cover or block any openings on this appliance.
- ✘ Store this appliance outdoors.
- ✘ Use this product near water (e.g., a kitchen sink, a wet basement, or a swimming pool).
- ✘ Immerse the cord or plug in water.
- ✘ Let the cord hang over the edge of a table or counter.
- ✘ Use a water jet for cleaning. Refer to the [Cleaning](#) section for proper cleaning procedures.
- ✘ Use this product without the bottom jet plate installed. The oven will not cook properly and damage to the oven may occur.

2.2 Reducing Fire Risk

- ✓ Remove wire twist-ties from paper or plastic bags used to facilitate cooking in the oven.
- ✓ If materials inside the oven ignite, keep the oven door closed, turn the oven off, and disconnect the power cord or shut off power at the fuse or circuit breaker panel.
- ✓ If smoke is observed, switch off or unplug the oven. Keep the door closed to stifle any flames.

2.3 Grounding Instructions

This appliance must be grounded. In the event of an electrical short circuit, grounding reduces the risk of electric shock by providing an escape wire for the electric current. This oven is equipped with a cord that has a grounding wire with a grounding plug, which must be plugged into an outlet that is properly installed and grounded. Consult a qualified electrician or serviceman if uncertain about the ability to follow grounding instructions or if in doubt as to whether the appliance is properly grounded.

⚠ WARNING: Improper grounding can result in risk of electric shock.

- Do not use an extension cord. If the power cord is too short, have a qualified electrician or serviceman install an outlet near the appliance.

2.4 Power Cord Replacement

If the power cord is damaged, it must be replaced by the manufacturer, its service agent, or a similarly qualified person.

⚠ WARNING: If the oven is unplugged during service or maintenance, the user must be able to always access and see the plug to ensure that the oven remains unplugged. The plug must remain near the oven and cannot be placed behind another appliance or in another room.

2.5 Excessive Microwave Energy Precautions

- Do not attempt to operate this oven with the door open since open-door operation can result in harmful exposure to microwave energy. It is important not to defeat or tamper with the safety interlocks.
- Do not place any object between the oven front face and the door or allow soil or cleaner residue to accumulate on sealing surfaces.
- Do not operate the oven if it is damaged. It is particularly important that the oven door close properly and that there is no damage to the: (1) Door (bent), (2) hinges and latches (broken or loosened), (3) door seals and sealing surfaces.
- The oven should not be adjusted or repaired by anyone except properly qualified service personnel.

2.6 RF Interference Considerations

This oven generates radio frequency signals. This device has been tested and was determined to be in compliance with applicable portions of FCC part 18 requirements and to the protection requirements of Council Directive 89/336/EEC on the approximation of the laws of the Member States relating to electromagnetic compatibility at the time of manufacture. However, some equipment with sensitivity to signals below these limits may experience interference. If your equipment experiences interference:

- ✓ Increase the physical separation between this oven and the sensitive equipment.
- ✓ If the sensitive device can be grounded, do so following accepted grounding practices.
- ✓ If battery-powered microphones are being affected, ensure that the batteries are fully charged.
- ✓ Keep sensitive equipment on separate electrical circuits if possible.
- ✓ Route intercom wires, microphone wires, speaker cables, etc., away from the oven.

2.7 Protective Earth (Ground) Symbol



This symbol identifies the terminal which is intended for connecting an external conductor for protection against electric shock in case of a fault, or the terminal of a protective earth (ground) electrode.

2.8 Equipotential Bonding Symbol



This symbol identifies the terminals which, when connected together, bring the various parts of an equipment or of a system to the same potential, not necessarily being the earth (ground) potential, e.g. for local bonding.

3. SPECIFICATIONS

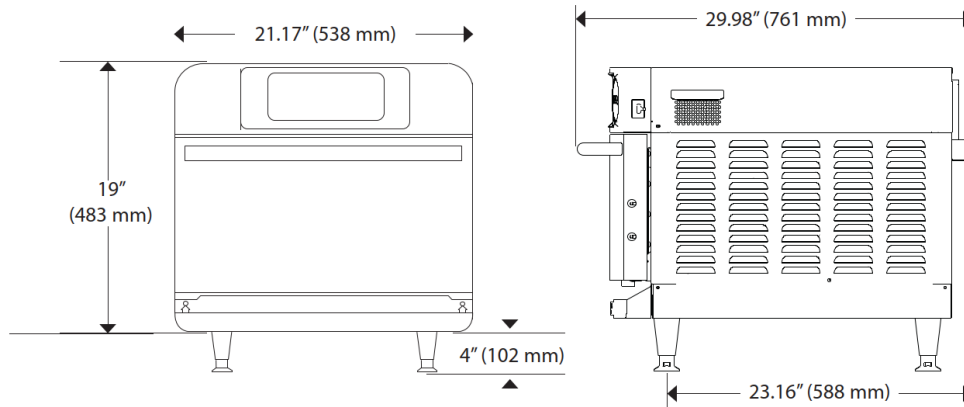

Figure 3-1: Bullet Oven Dimensions

3.1 Theory of Operation

The TurboChef Bullet oven uses radiant heat, high-speed air impingement, and a side-launched microwave to cook food rapidly without compromising quality. Performance and menu versatility are maximized by flexible top- and bottom-temperature settings and the ability to adjust microwave and airtime for each recipe. This manual includes instructions for installing, cleaning, and operating the oven. If you have questions that are not addressed in this manual, contact [Customer Support](#) or your authorized distributor.

3.2 Features

- Capacitive touch screen with industrial-grade tempered glass cover
- Manual mode for on-the-fly cooking
- Localized translations
- Enhanced data logging for troubleshooting and identifying what products are being cooked and when.
- New menu editing tools and USB
- Wi-Fi/Open Kitchen™ ready

3.3 Dimensions

Oven Dimensions	
Height - Single Oven	with legs: 23" (584 mm)
	without legs: 19" (483 mm)
Height - Stacked Ovens	lower oven with legs: 42" (1067 mm)
	lower oven without legs: 38" (965 mm)
Width	21.17" (538 mm)
Depth	footprint: 27.51" (699 mm)
	door closed: 29.98" (761 mm)
	door open: 36.47" (926 mm)
Weight	185 lb. (84 kg)
Cook Cavity Dimensions	
Height	6.0" (152 mm)
Width	15.5" (394 mm)
Depth	14.5" (368 mm)

SPECIFICATIONS

Volume	0.78 ft ³ (22.1 liters)
Clearances	
Top:	5" (127 mm)
Sides:	2" (51 mm)

3.4 Certifications

cULus, UL EPH, TÜV, CE, FDA



3.5 Oven Construction

- Exterior
 - Stainless steel front, top, and sides
 - Stainless steel removable grease collection pan
 - Cool-to-touch exterior; all surfaces below 131 °F (55 °C)
 - Ergonomic door handle
 - 7-inch capacitive touch screen with tempered glass cover
- Interior
 - 201 stainless steel
 - Fully welded and insulated cook chamber
 - Removable rack and lower jet plate

3.6 Electrical Specifications

TurboChef recommends a Type D circuit breaker for all installations outside the United States.

Single Phase (6200 watts)

US/Canada: 208/240 VAC*, 60 Hz, 30 A

Europe/Asia (UK): 230 VAC, 50 Hz, 30 A

Brazil (BK): 220 VAC, 60 Hz, 30 A

Latin America (LA): 220 VAC, 60 Hz, 30 A

Japan (JK): 200 VAC, 50 or 60 Hz, 30 A

Multiphase (6200 watts)

Europe/Asia Wye (EW): 400 VAC, 50 Hz, 16 A

Europe/Asia Delta (ED): 230 VAC, 50 Hz, 30 A

Japan Delta (JD): 200 VAC, 50 or 60 Hz, 30 A

Korea/Middle East Wye (KW): 400 VAC, 60 Hz, 16 A

Korea/Middle East Delta (SD): 230 VAC, 60 Hz, 30 A

* US/Canada models include a voltage sensor that detects 208 or 240 VAC but does not compensate for lack-of or over-voltage installations.

4. INSTALLATION

Install or locate this appliance only in accordance with the instructions below.

⚠ WARNINGS:

- The oven weighs approximately 185 lb (84 kg). Never lift with fewer than two people.
- Never lift the oven by the door handle. Doing so will cause the door to misalign, resulting in a non-warranty service call.
- The oven must be correctly placed on a food station at all times. TurboChef will not accept a fallen oven as a warrantable claim and is not responsible for any injuries that may occur.
- This oven is not intended for built-in installation, such as installing the oven within any structure that encircles it on five or more sides. Ensure there is at least 2" (51 mm) of clearance on all sides and 5" (127 mm) of clearance on the top.
- This oven should not be stacked without proper hardware. Contact TurboChef for more information.
- Never stack ovens more than two high

4.1 Unpacking Instructions

1. Remove the oven from its packaging.
2. Before discarding, check the packaging thoroughly for accessories and literature.
Note: Keeping the packaging is recommended in case the oven may be shipped to another location.
3. Check the cook cavity thoroughly for packaging, accessories, and literature.
4. Discard any packaging in the cook cavity.

4.2 Oven Installation

1. Prepare a surface capable of supporting 190 lb (86 kg) or 380 lb (172 kg) if stacking.
2. The surface must be 27.45" (697 mm) deep.

If	Then
Installing onto an oven cart <i>Note: For details, contact Customer Support.</i>	<ol style="list-style-type: none"> 1. Ensure the oven cart casters are locked. 2. Ensure the oven legs are removed. 3. Drilling additional holes in the counter surface/cart for stability is required if the existing holes in the cart/surface do not align with the leg holes of the oven. 4. Position one or more people at the front and back of the oven. 5. Place your hands under the oven and lift. 6. Place the oven on the prepared surface, ensuring no edges are hanging off the sides.

INSTALLATION

If	Then
Stacking two ovens	<ol style="list-style-type: none"> 1. Refer to the Dimensions section. 2. Install the stacking bracket (part number ENC-3001) to the lower oven. 3. Place the upper oven on top of the lower oven. 4. Secure the bracket to the top oven.

3. Ensure the oven rack is properly installed to each oven (attached to the bottom jet plate).
4. Plug in the oven.

Note: The oven is primarily serviced through its sides and top. Shelving installed directly over the unit may delay servicing. The owner will be responsible for paying service costs for additional time spent accessing the oven.

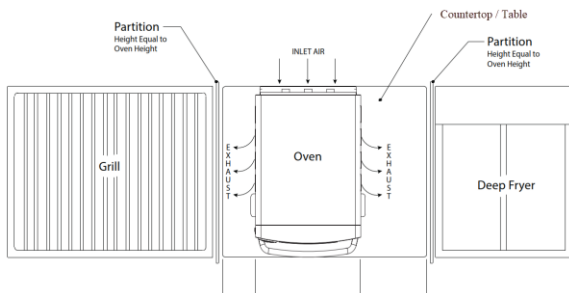

Figure 4-1: Installation Near Open Heat Source

4.1 Oven Restraint Kit

Part Number: TC3-0242

⚠ WARNING: The Oven Restraint Kit will not prevent the oven from falling off a countertop if the oven is pulled off or allowed to slide off the edge. Installation instructions are included with the kit.

4.2 Installation Near Open Heat Source

When placing a TurboChef oven near an open heat source (see [Figure 4-1](#)), verify that the oven is located with a minimum of 5" (127 mm) of clearance above and a

minimum of 2" (51 mm) on each side.

Note: The height of the divider must be greater than or equal to the height of the oven.

If	Then
The oven is being placed near a grill or stove	A divider must exist between the oven and the open heat source, with a minimum of 6" (152 mm) between the oven and the divider.
The oven is being placed near a fryer	A divider must exist between the oven and fryer, with a minimum of 12" (305 mm) between the oven and the divider.

4.3 ChefComm One Touch

Part Number: [CON-7006](#)

ChefComm OneTouch lets you easily create menu settings on a computer and upload them to an oven via USB. For more information, contact [Customer Support](#).

4.4 Open Kitchen

Open Kitchen® from Powerhouse Dynamics, a Middleby company, is an Internet of Things (IoT) solution used by foodservice operators to connect and monitor HVAC, refrigeration, and foodservice cooking equipment across any brand. This level of connectivity provides access to real-time data on food prep and storage, tracks and manages energy use on HVAC equipment, provides visibility into key performance indicators, and empowers chefs to remotely distribute recipe updates to cooking equipment, which is a big asset for chains and multi-location restaurants. Open Kitchen connectivity is now available as a bundled option with your newly purchased TurboChef equipment.

4.5 ConnectWare

ConnectWare® is a versatile, plug-and-play communications module that enables equipment in restaurants, retailers, and other facilities to connect to the Cloud. Powerhouse Dynamics developed ConnectWare to shift the burden and cost of communications support from OEMs and to provide a consistent yet flexible method that enables their equipment to communicate. ConnectWare plugs into a factory-installed ConnectWare Dock; no installation required. **ConnectWare supports multiple communications protocols:**

- Wi-Fi (includes the highly secure Microsoft Azure Sphere® chipset)
- Ethernet version also available
- Plug-n-play across protocols, making it “future proof”

4.6 Voltage Selection

For North American oven models, the oven detects either 208 or 240 VAC. If the incoming voltage at the store differs from the factory-preset voltage, the operator must select either **208** or **240**. The correct voltage will be highlighted on the screen, indicating which option to choose.

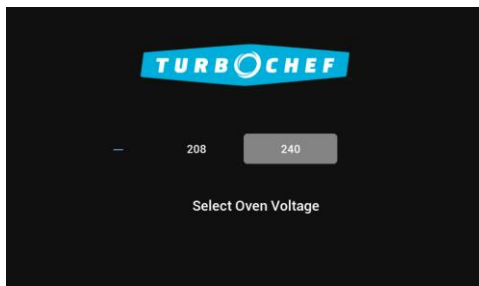

4.7 Ventilation

The TurboChef Bullet oven has been approved by Underwriters’ Laboratory for ventless operation (UL KNLZ listing) for all food items except for foods classified as “fatty raw proteins.” These foods include bone-in, skin-on chicken, raw hamburger meat, raw bacon, raw sausage, steaks, and similar items. If cooking these types of foods, consult local HVAC codes and authorities to ensure compliance with ventilation requirements. To maintain compliance with all health, building, and fire codes, you must keep the area around your oven clean and sanitary at all times.

Note: The manufacturer is not responsible for damages or injuries caused by installations that do not follow the listed instructions and codes. Failing to follow these instructions may result in a temporary cease-and-desist order from the local health department until environmental concerns are resolved.

5. CLEANING

5.1 Daily Maintenance

Follow the steps below when cleaning your oven. Use only TurboChef®-approved cleaning chemicals. Failing to follow these procedures or using other cleaning products may damage essential oven components, resulting in a non-warranty service call.

1. Cool the Oven.

⚠ WARNING: The oven operates at approximately 500 °F (260 °C) and may cause injury if not allowed to cool properly.

- a. Turn off the oven by touching the **Off** icon.
- b. Partially open the oven door and allow the oven to cool for approximately 30 minutes.
- c. Do not proceed to step 2 until the oven displays **ready to clean**.

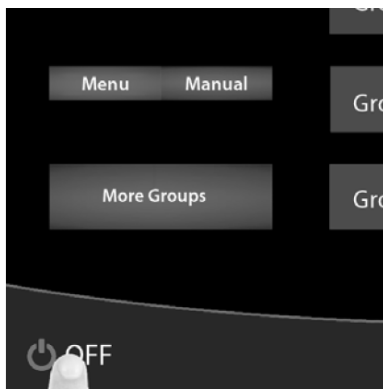

2. Clean the baking stone.

- a. Remove the baking stone and gently dry scrub with a nylon scrub pad to remove food particles.
CAUTION: Scrubbing too vigorously can cause the baking stone to crack and break.

5.2 Supplies and Equipment

TurboChef®-approved oven cleaner; nylon scrub pad; clean, damp, and dry towels; disposable gloves; protective eyewear; dust mask (optional).

- b. Do not immerse the baking stone in water. If immersed, allow it to air-dry completely before use to avoid cracking.

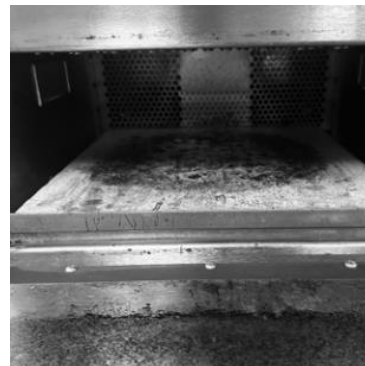

3. Clean the jet plate.

- a. Lift the front of the jet plate.
- b. Pull the jet plate forward and remove it from the oven.
- c. Wash, rinse, sanitize, and dry the jet plate.
- d. Do not clean the jet plate with a wire brush.



4. Clean the cavity filter (if present).
 - a. The cavity filter must remain installed during oven operation and should be cleaned regularly or replaced if damaged.
 - b. Lift the tab to detach the cavity filter from the rear cavity wall, then pull the filter toward you.
 - c. Rinse the filter with hot water.
 - d. Allow the filter to dry completely.
 - e. Do not scrub or pull apart the mesh in the filter frame.



5. Clean the back air filter.
 - a. The air filter must remain installed during oven operation and should be cleaned regularly or replaced if damaged.
 - b. Remove the air filter from the back of the oven and rinse with hot water.
 - c. Allow the air filter to dry completely.



6. Remove large food particles.
 - a. Lift the heating element to access the area beneath it.
 - b. Use a food vacuum or a damp towel to remove large particles from the oven cavity.

Note: Do not attempt to clean the heating element.



7. Clean the oven cavity.
 - a. Do not spray oven cleaner into cavity openings.
 - b. Apply oven cleaner to a towel or nylon scrub pad and clean the top, sides, and bottom of the cavity.
 - c. Do not apply excessive pressure to the waveguide covers (A), located on each side of the cavity.

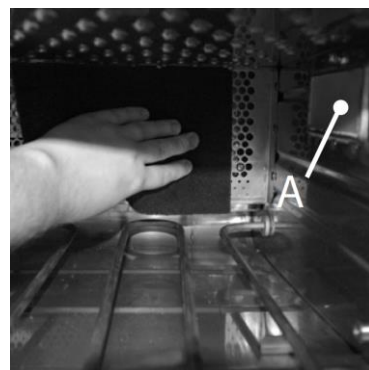

- d. For stubborn stains, lightly spray oven cleaner on the stain and allow the cleaner to penetrate for five minutes, then wipe clean.
- e. Do not use a hose or water jet for cleaning.

- 8. Wipe down the oven cavity.
 - a. Wipe down the oven cavity with a damp towel.
 - b. Dry the oven cavity with a dry towel.



- c. Close the oven door.
 - d. Reinstall the filter or replace it with a new one if the mesh is damaged, loose, or deteriorated.

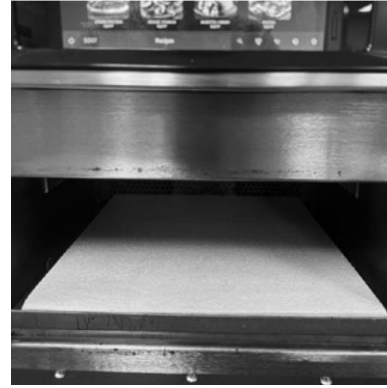

- 9. Clean and dry the oven door.
 - a. Clean all door surfaces using oven cleaner and a nylon scrub pad.
 - b. Wipe the oven door with a damp towel.
 - c. Dry with a dry towel.



- 11. Clean the oven exterior.
 - a. Wipe the oven exterior with a damp towel.
 - b. Remove the panel beneath the door, remove any food particles, and wipe it clean.
 - c. Reinstall the crumb tray beneath the door.
 - d. Do not spray chemicals into openings such as side louvers or the rear vent housing.
 - e. The oven is ready for operation.



- 10. Reinstall components.
 - a. Reinstall the cavity filter (if present), aligning the top-left post with the top-left hole in the rear cavity wall.
 - b. Reinstall the jet plate and baking stone.

Note: Do not operate the oven without the bottom jet plate installed. Doing so may damage the oven.

5.3 Quarterly Maintenance

To ensure optimal oven performance, complete the following cleaning steps quarterly, or more frequently as required.

1. Complete the [Daily Maintenance Instructions](#).

CAUTION: Make sure the oven is off before proceeding.

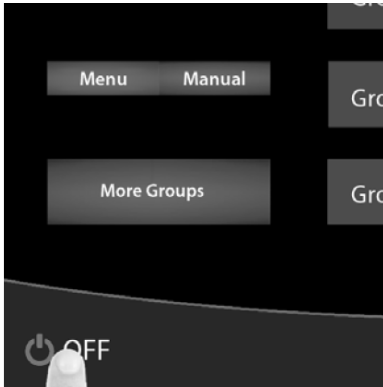

2. Remove the air filter.

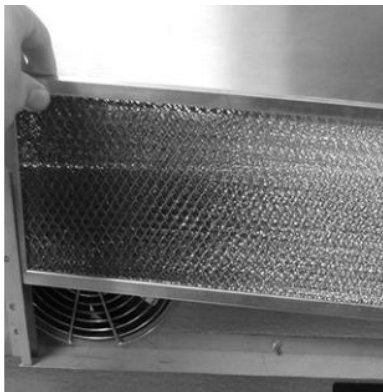

5.4 Supplies and Equipment

Required: Phillips screwdriver, clean towels, and rubber gloves for handling the catalytic converter. Recommended: dust mask, vacuum, brush, or paintbrush.

3. Clean the cooling fans and finger guards.

Note: A bristle or paintbrush and a vacuum are recommended for collecting debris.



4. Clean the louvers on both side panels.

Note: A bristle or paintbrush and a vacuum are recommended for collecting debris.

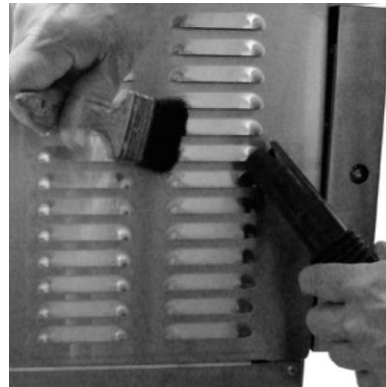

- 5. Using a Phillips screwdriver, remove the screws from the rear vent catalyst housing, supporting the cover with your hand.



- 6. Remove the cover slowly to keep the catalytic converter in place.
Note: The catalytic converter is accordion style and will pop out when the cover is removed.

CAUTION: Do not attempt to clean the catalytic converter or spray chemicals in this area.



- 7. Reattach the outer cover, making sure the vent holes are at the bottom.

CAUTION: Installing the outer cover upside down may cause excessive grease buildup and/or steam when the oven door is opened.



- 8. Wipe down the back panel with a clean, damp towel.



- 9. Reinstall the air filter.
- 10. The oven is ready to turn on.



6. ONETOUCH CONTROLLER OPERATION

Note: Display options vary depending on which features are enabled.

1. Power Icon

Tap to start preheating. By default, the oven warms up to the lowest preset temperature.

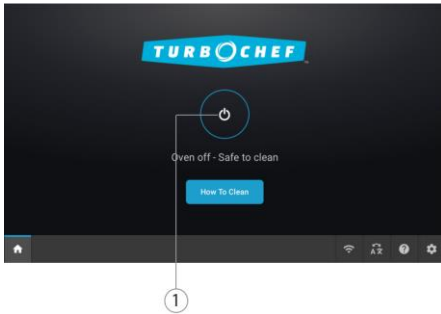

2. Group Select

Select a group, and the oven will preheat to its set temperature. The set temperature will be displayed near the group name. If **All Recipes** is selected, the oven will preheat to the lowest recipe temperature in the menu.

3. Off Icon

Touch to turn the oven off (cool down).

4. Temperature Icon

While the oven preheats, touch to view the progress. When the oven is at temperature (idle), this button is inactive but still displays the oven temperature for informational purposes.

5. Recipe Mode

When in Manual Cook Mode or Preheat Progress, touch **Recipes** to return to Recipe Cook Mode. If the oven is preheating, you cannot select recipes until the set temperature is reached.

6. Manual Cook Mode

Touch to enter Manual Cook Mode.

7. Wi-Fi Network/Network Settings

If the oven is connected to Open Kitchen™ via Wi-Fi or Ethernet, connection status information will be visible here.

8. Settings Mode (gear icon)

Touch to access Settings Mode. A pass code (9 4 2 8) is required.

9. Edit Mode (pencil icon)

The Edit icon will only be displayed when [Edit Mode](#) is enabled. Touching this icon lets you edit menu items.

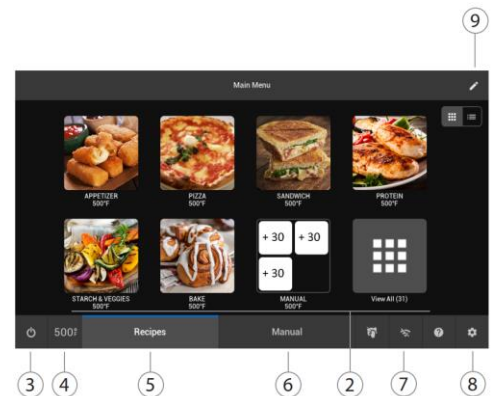

10. Preheat Progress

Indicates preheat progress; touch the temperature icon (4) to view.

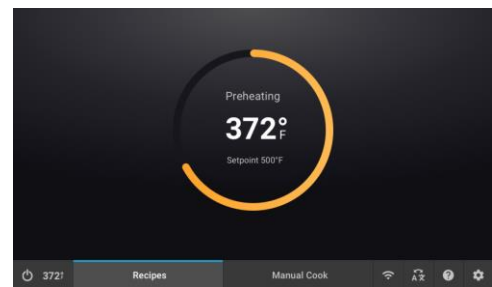

6.1 Recipe Mode

The oven is preprogrammed with recipe settings at the time of manufacture and is ready to operate out of the box. New menu settings can be loaded via USB (see [Load Menu from USB](#)) or programmed manually. If settings are missing, the oven will operate only in manual mode. This oven uses impingement and microwave technology to cook food faster than traditional methods. Air enters the cavity from the top and bottom using a single fan. To ensure uniform cooking, the oven must be operated only with the bottom jet plate in place. While the bottom jet plate is removable for cleaning, it cannot be removed during cooking. Without the bottom jet plate, the oven will not deliver proper cooking performance to the top or bottom of the food, and damage to the oven may occur. The sequence of the steps below may vary, and some may not apply.

1. Touch the power icon to begin preheat.
2. Select a group to select a set temperature.

Note: The OneTouch controller allows temperature to be set per recipe and then groups recipes by temperature. If multiple groups contain the same set temperature, then select any one of them to preheat. Until a group is selected, the oven will preheat to the lowest set temperature in the menu.

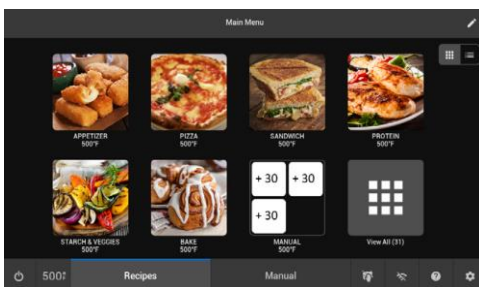

3. Allow the unit to preheat.

Note: After the oven warms up, it will “soak” for an additional eight minutes. “Soaking” ensures that the cavity surfaces absorb enough heat to prevent affecting cooking. While the oven preheats, tap the “Recipes” button to view recipes or select a new group.

4. Place food in the oven and select a recipe

CAUTIONS:

- Inside of oven and oven door are hot!
- Opening the oven door while the cook timer is counting down may reduce the service life of critical oven components

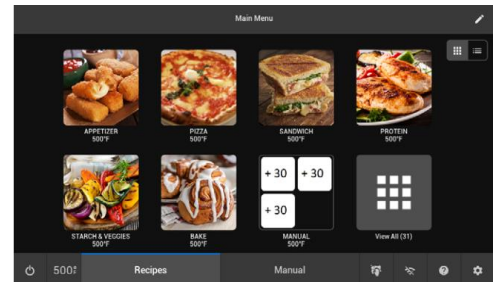

Notes:

- To immediately stop a cook cycle, touch the red X.
- If the oven door is opened during a cook cycle, the cycle will pause until the door is closed.

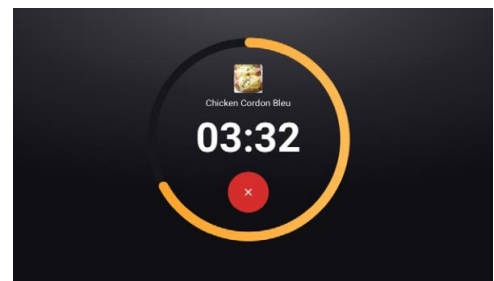

- 5. Review for cooking alerts

Note: Some recipes may include alerts that require action while cooking.

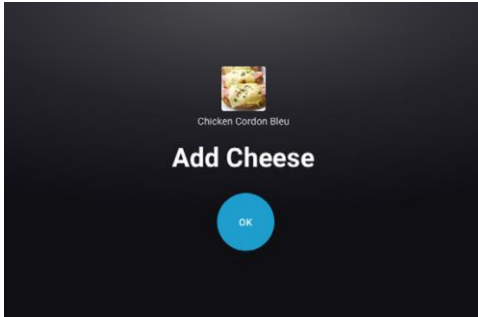

- 6. Check/remove food from oven

CAUTION: The inside of the oven and the door are hot!

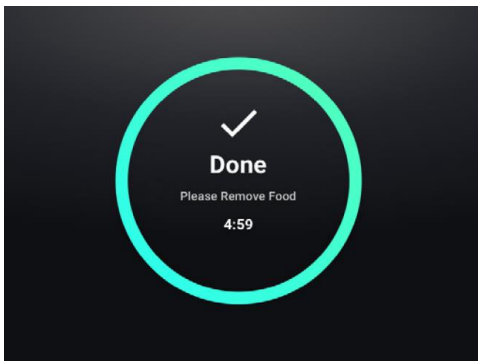

- 7. Cooling down

Note: When finished cooking for the day, touch the power button (in the bottom-left corner) to begin cooling.



6.2 Manual Cook Mode

Manual Cook Mode allows cooking “on the fly,” whereas Recipe Mode allows cooking from preset cook settings. To access Manual Mode, touch **Manual** when the oven is preheating or idling in the Recipe Mode.

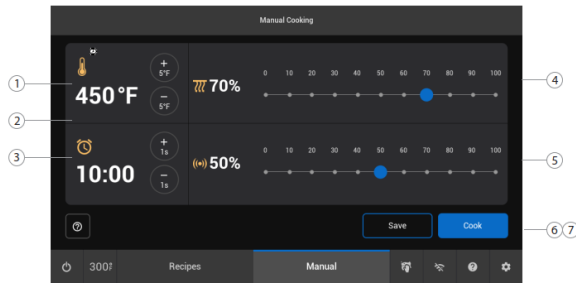

1. **Set Temperature**

Temperature can be set by touching or holding down the +5° or -5 ° buttons.

2. **Bottom Temperature Offset**

The bottom temperature offset allows the bottom heater to deliver heat, yielding different browning results. The allowable range is (-35) to +75 in either °F or °C.

3. **Time**

Time can be set by touching or holding down the +1 or -1 buttons.

4. **% Air**

% Air determines the airflow rate. The more air, the more the product will brown or crisp. % Air can be set from 0% to 100% in 10% increments.

Note: The Bullet oven does not have independently controlled top and bottom air.

5. **% Microwave**

% Microwave determines the microwave power, which can be set from 0-100% in 10% increments. For example, 50% means the microwave system will remain on for five continuous seconds for every ten seconds during the cook cycle.

6. **Save to Menu**

If you want to save a manual mode setting as a recipe, touch **Save**.

7. **Cook**

Touch to cook.

Note: The oven may require additional warm-up time before cooking.

6.3 Settings Mode

To access Settings Mode, touch the Settings icon and enter the passcode 9 4 2 8. From the Settings Mode, access:

Note: Additional settings are available for technician or production test logins.

- Data Plate
- Data Log
- Oven Settings
- Fault Counts
- Fault History
- Service Settings
- Network

6.3.1 Oven Settings

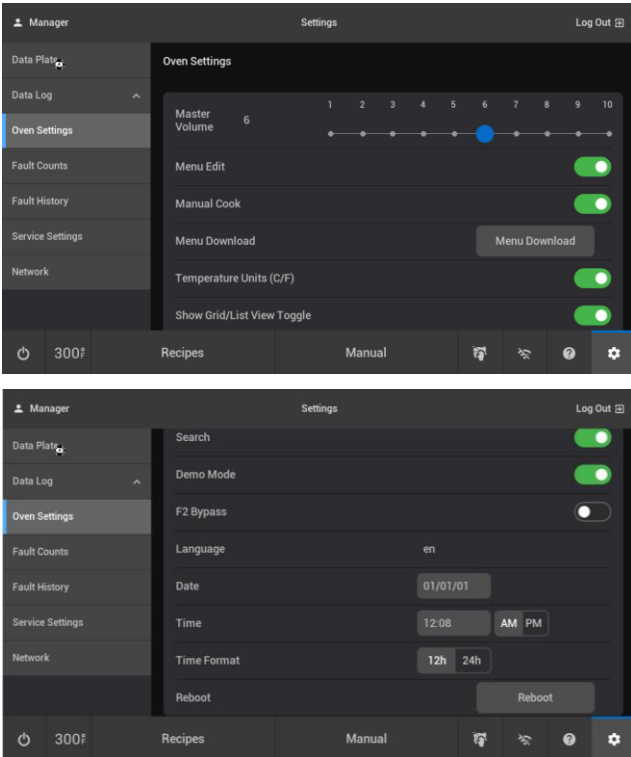

- **Master Volume**
Set the volume from 1 to 10.
- **Menu Edit**
Enable or disable the button that allows the operator to edit recipe settings.
- **[Manual Cook](#)**
Enable access to Manual Cooking mode.
- **[Menu Download](#)**
When the oven is off or cooling, insert the USB and select **Save to USB**. Refer to the [Load Menu from USB](#) section to load from a USB.
- **Temperature Units (C/F)**
The temperature measurement setting is configured at the factory. Touch to change the temperature measurement settings.

- **Show Grid/List View Toggle**
Enable or disable the button that lets the operator toggle between icon/tile and list views on the Group and Recipe screens.
- **Search**
Allows for a quick recipe search.
- **Demo Mode**
Demo Mode lets you demonstrate the oven's cooking capabilities without turning on the heaters or microwave system. Demo Mode must be disabled during regular operation.
- **F2 Bypass**
The F2 alarm signals that the oven temperature is too low. When F2 Bypass is enabled, the oven will not stop a cook cycle if an F2 alarm occurs, but will still log the fault. When F2 Bypass is disabled, the oven operates normally, meaning that if an F2 alarm happens during a cook cycle, the oven will stop the cook cycle.
- **Language**
The default language is English. To change to another language, touch **Language: English** and then touch the preferred language and touch **ENTER**. The available languages are:
 - French
 - German
 - Polish
 - Portuguese
 - Russian
 - Spanish
 The available languages may also be:
 - Chinese
 - Korean
 - Japanese

- **Date/Time/Time Format**

The final three options allow the user to set the date, time, and time format. If the oven is connected to the internet, the date and time will synchronize with an online world clock.

- **Reboot**

Restarts the controller/equipment.

- **Network**

If the oven is connected to a ConnectWare module or via Ethernet, connection status information will be displayed here. Wi-Fi credentials (if applicable) can also be entered or changed.

6.4 Edit Mode

1. To enable Edit Mode, touch the Settings icon.
2. Touch **Login** to access the **Operation Settings** screen.
3. When prompted, enter passcode 9 4 2 8 and then touch **Enter**.
4. Set the **Editing** toggle to the on position. The Editing icon appears in the top-right corner of the screen when in menu mode. The operator can create, delete, move, or edit a group or item.

6.4.1 Creating a Group

Note: Cancel this process at any time by touching the X in the top-right corner.

1. From the group select screen, touch the **Edit** button in the top-right corner of the screen. If the edit button is not present, verify it is enabled in the [Settings menu](#).

2. Touch the **+Group** button.



3. Enter the group name.
4. Touch the blue arrow button to continue.

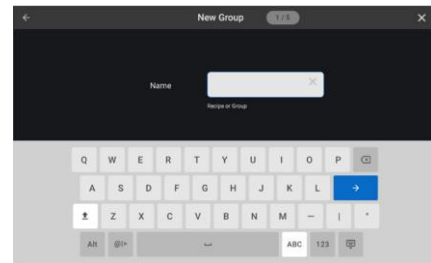

5. Select an image and touch the blue **Save** button.

*Note: If you have a USB drive with image files inside a folder named **Images**, insert it from this screen and select **USB** to assign the image.*

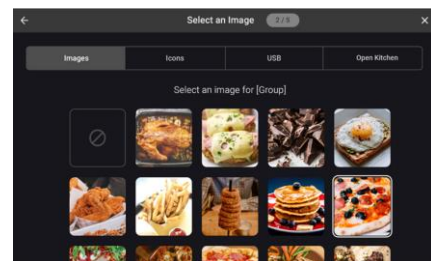

6. Enter the idle offset temperature.
 7. Touch the blue arrow button to continue.
- Note: The offset temperature varies by recipe; it allows the bottom heater to deliver precise heat to achieve different browning results. For optimal performance, the idle setting should match the typical offset values in the recipes assigned to this group.*

8. Add recipes (or subgroups) to the group by selecting/deselecting each recipe.
9. Touch **Next**.

Note: The set temperature in the first recipe sets the group temperature. Recipes developed at a different set temperature will not be available after selecting the first recipe.

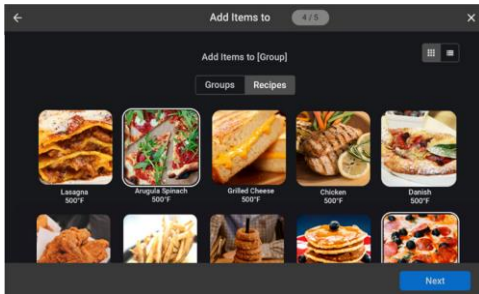

10. Drag the recipe icons to sort.
11. Touch **Save** once complete.

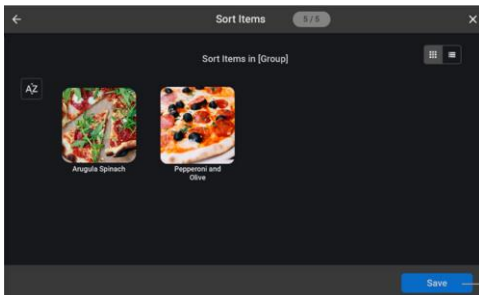

6.4.2 Editing a Group

Note: Cancel this process at any time by touching the X in the top-right corner.

1. From the group select screen, touch the **Edit** button in the top-right corner of the screen. If the edit button is not present, verify it is enabled in the [Settings menu](#).
2. Touch the pencil icon button to edit the desired group.

3. Select an option.

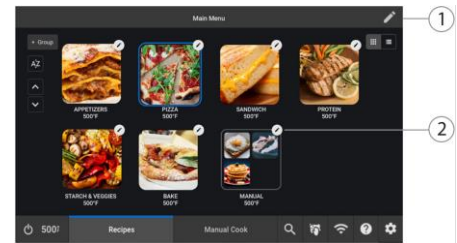

4. Edit one of the following:
 - **Group Name**
 - **Edit Recipes**
 - **Idle Offset Temperature**
 - **Image**
 - **Remove**
 - **Remove Group**

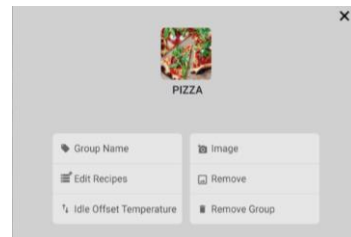

6.4.3 Creating a Recipe

Note: Cancel this process at any time by touching the X in the top-right corner.

1. From the group select screen, touch the **Edit** button in the top-right corner of the screen. If the edit button is not present, verify it is enabled in the [Settings menu](#).
*Note: To create a recipe without selecting a group, select **all** recipes.*
2. Touch the **+Recipe** button.

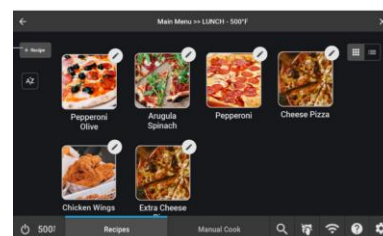

3. Select **New**.
4. Enter the recipe name.
5. Touch the blue arrow button to continue.
Enter the search keywords.
6. Touch the blue arrow button to continue.
7. Select an image and touch **Next**.

*Note: If you have a USB drive containing image files in a folder called **Images**, insert it from this screen and select **USB** to assign the image.*

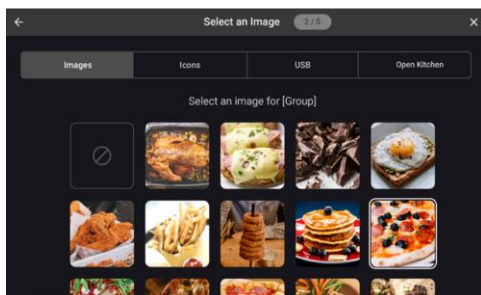

8. Enter the recipe temperature.
9. Touch the blue arrow button to continue.
Note: This option only appears if you select the Create Recipe feature on the All Recipes screen. Otherwise, the recipe's temperature is inherited from the group where the +Recipe was chosen.
10. To add cook settings, complete the following:
 - a. Touch the **+** button to add a stage.
 - b. Touch the stage to reorder it or to edit the cook settings, including:
 - Cook time per stage
 - Percent air per stage
 - Percent microwave per stage
 - c. Touch the trash can to delete a stage.
 - d. Touch the note bubble to add a cooking note that will appear in the cook cycle between stages.
 - e. Touch the left or right arrows to rearrange stages.

- f. Touch **Cook** to perform a test cook.
- g. Touch **Save** to continue.
- h. Touch the back arrow to return to the previous step.

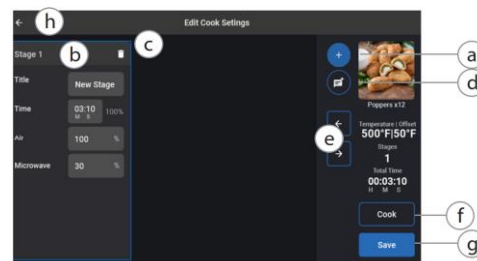

11. Select which group(s) the recipe will be added.
12. Touch **Next** (or **Skip** if no groups are selected).

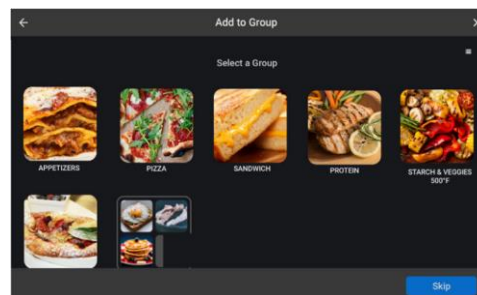

6.4.4 Adding a Recipe to a Group

Note: Cancel this process at any time by touching the X in the top-right corner.

1. From the group select screen, select a group to add or create a recipe.
*Note: To create a recipe without selecting a group, select the **all recipes** button.*
2. Touch the Edit button in the top-right corner of the screen.
3. If the edit button is not present, verify it is enabled in the [Settings menu](#).
4. Touch the **+Recipe** button.
5. Select **Existing**.

6. Select a recipe (or recipes) to add to the group.
Note: Only recipes with set temperatures that match the group's set temperature are selectable.
7. Touch **Next**.
8. Sort recipes within the group by holding and dragging items into place.
9. Touch **A/Z** to organize them alphabetically.
10. Touch **Save** once complete.

6.4.5 Editing a Recipe

Note: Cancel this process at any time by touching the X in the top-right corner.

1. From the group select screen, touch the **Edit** button in the top-right corner of the screen. If the edit button is not present, verify it is enabled in the [Settings menu](#).

*Note: To edit a recipe without selecting a group, select the **all recipes** button.*

2. Touch the Edit icon for the group being modified.

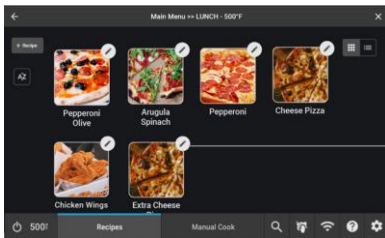

3. Select an option:
 - a. Edit the recipe name and/or keywords for the search option.
 - b. Change the recipe image/icon.
 - c. Edit the recipe temperature.

Note: Changing the temperature will cause the recipe to lose its current group associations.

- d. Edit the recipe offset temperature.
- e. Edit the cook settings.
- f. Copy the recipe to a new group or groups.
- g. Move the recipe to a new group or groups.
- h. Remove/delete the recipe.

6.5 Load Menu from USB

When loading from a USB, the recipe file and images/icons must be compressed into a TGZ file. If saving the menu from the oven (see below), the oven will create the TGZ file in a format that can be easily loaded into other ovens. ChefComm OneTouch also creates TGZ files for recipe updates.

TGZ menu files are not backward compatible with the legacy controller.

When the oven is off or cooling down, insert the USB (see below).

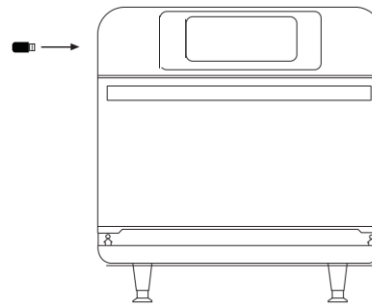

The oven will automatically detect the device. Select **Update** to proceed or **Cancel**. The update will take several seconds, after which the controller will reboot one or two times. After the controller reboots, wait 10 seconds and then remove the USB drive.

Note: The process is identical for updating oven firmware. Do not update firmware unless instructed by the factory.

7. LEGACY CONTROLLER OPERATION

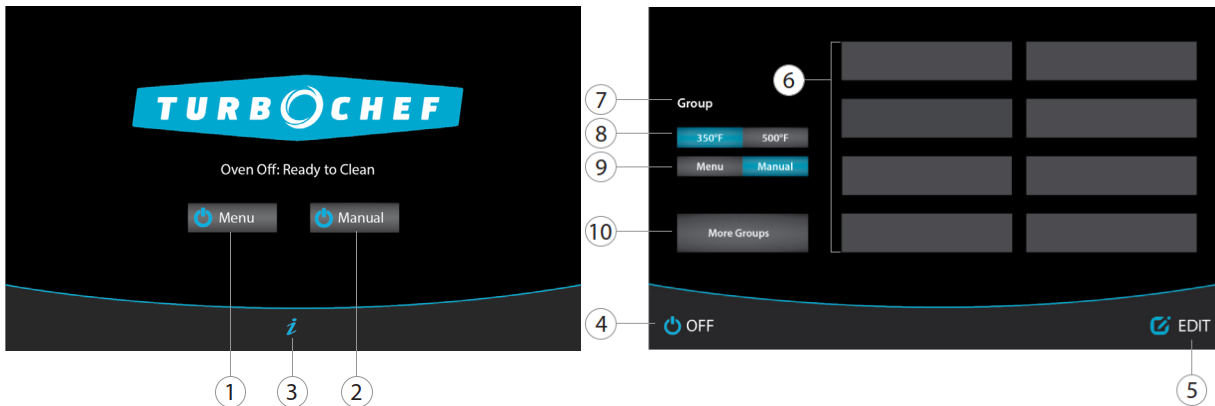

Note: Display options vary depending on which features are enabled.

7.1 Oven Controls: Legacy

1. [Menu Cook Mode](#)

Touch to turn on the oven and to cook in the menu cook mode.

Note: If Manual Mode is disabled, a temperature icon will be shown instead of the menu icon.

2. [Manual Cook Mode](#)

Touch to turn on the oven and cook in manual cook mode. The Manual icon is only present if enabled.

3. [Info Mode \(i icon\)](#)

Touch to access Info Mode. The i icon is only displayed when the oven is off, warming up, cooling down, or in edit mode.

4. **Off Icon**

Touch to turn the oven off (cool down).

5. **Edit Mode**

The Edit icon will only be displayed when Edit Mode is enabled. Touching this icon lets you edit menu items.

6. **Groups/Items (1-8 and 9-16)**

The oven contains 16 food groups divided into 2 groups of 8. Each food group contains 16 items divided into 2 groups of 8.

7. **Group Name**

When viewing items, the group name indicates which group is being displayed.

8. **Set Temperature Toggle**

The set temperature toggle appears only when two different set temperatures are selected. Touch the toggle to view groups from the other set temperature.

9. **Menu/Manual Toggle**

The Menu/Manual toggle appears only when manual cooking is enabled and lets you switch between menu and manual modes.

10. **More/Previous Groups or Items**

This icon will only be displayed when using one set temperature. To view additional groups or items, touch **More Groups** or **More Items**. Or, if on screen two, touch **Previous Groups** or **Previous Items**.

7.2 Menu Cook Mode

The oven is preprogrammed with recipe settings at the time of manufacture and is ready to operate out of the box. New menu settings can be loaded via USB or programmed manually. If settings are missing, the oven will operate only in manual mode. This oven uses impingement and microwave to cook food faster than traditional cooking methods. Air enters the cavity from the top and bottom using a single fan. Because of this design and to ensure uniform cooking, the oven must be operated only with the bottom jet plate in place. While the bottom jet plate is removable for cleaning, it is not removable for cooking. Without the bottom jet plate in place, the oven will not deliver the proper cooking performance to either the top or bottom of the food item. Additionally, oven damage may result. The sequence of the steps below may vary, and some may not apply.

1. Touch **Menu** or the oven set temperature Icon to turn on the oven.

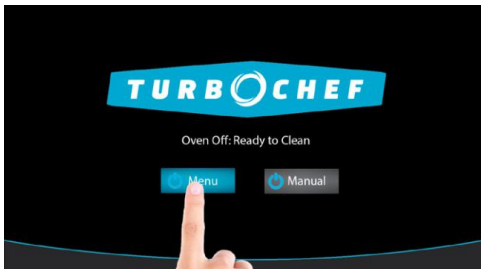

2. Select the cook temperature.

Notes:

- If the temperatures are the same, or if Manual Mode is disabled, this screen will be skipped.

- When the oven finishes warming up, it will soak for an additional eight minutes. This allows the cavity surfaces to absorb enough heat so that cooking won't be affected.

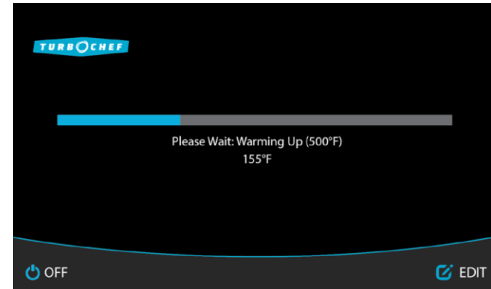

3. Place food in the oven.

⚠ WARNING: The inside of the oven and the oven door are hot!

4. Select a **Group**.

Note: Touch More Groups to view additional groups.



5. Select an **Item**.

Note: Touch More Items to view additional items.



6. Check/remove food from oven.

⚠ WARNING: Dish/inside of oven and door are hot!

CAUTION: Touch STOP before opening the door during a cook cycle. Opening the oven door while the cook timer is counting down could reduce the service life of critical oven components.

Notes:

- To immediately terminate a cook cycle, touch **STOP**.
- If the oven door is opened during a cook cycle, the cycle will pause until the door is closed. Touch **YES** to resume.

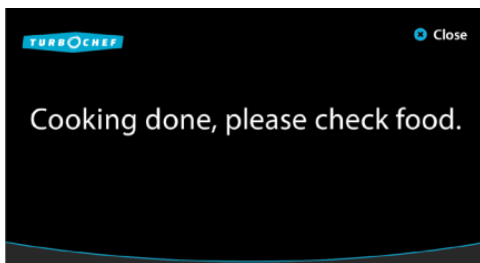
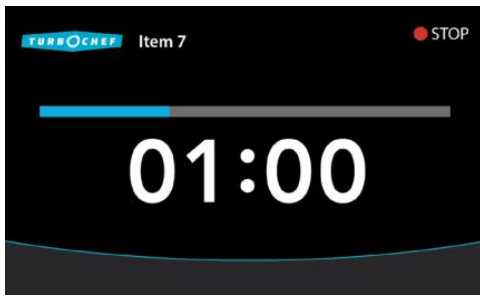

7. To cook an item longer than its original cook time, touch one of the icons on the screen:

Note: This option must be enabled to cook an item beyond its original cook time.

- Touch **Cook More** if the inside of the food item requires cooking.
- Touch **Brown More** if the outside of the food item requires browning or crisping.

- Touch **Cook & Brown More** if both the inside and outside of the food item require cooking. Selecting one of these options will cook the item for 20% of the last selected cook time. The minimum cook time is the shorter of 15 seconds and the original cook cycle. The maximum cook time is one minute. The oven will cook at the settings listed below:
- Cook More: 10% air, 100% microwave
- Brown More: 100% air, 0% microwave
- Cook & Brown More: 100% air, 100% microwave

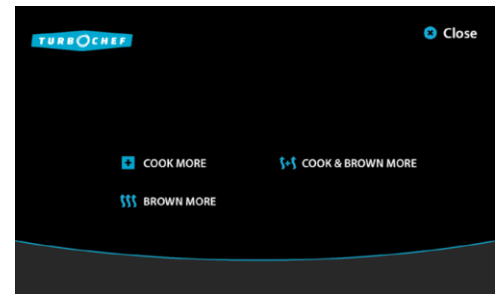

8. When finished cooking for the day, touch **OFF** to turn the oven off and begin cooling down.



7.3 Manual Cook Mode

Manual Cook Mode allows cooking on the fly, whereas [Menu Cook Mode](#) allows cooking from preset cook settings. To access Manual Mode, touch the Manual icon when the oven is off or cooling down, or touch the Menu/Manual toggle on the Menu Mode screen.

*Note: If the **Manual** icon is not present.*

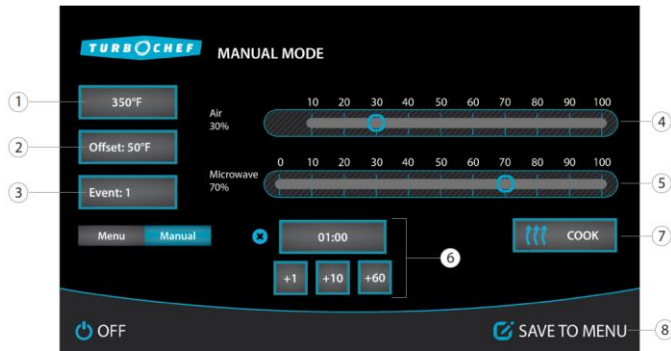

1. **Set Temperature**

Touch to change the set temperature. The temperature range is 300–600 °F (149–316 °C).

2. **Bottom Temperature Offset**

The bottom temperature offset allows the bottom IR element to provide additional heat, resulting in deeper browning. The allowable range of additional bottom heat is 0-75 in either °F or °C.

3. **Events**

Manual Mode can store six unique cook settings, called events. Touch **Events** to view settings for events 1 through 6.

4. **% Air**

% Air determines the airflow rate. The more air, the more the product will brown or crisp. % Air can be set from 10-100% in 10% increments.

5. **% Microwave**

% Microwave determines the microwave power, which can be set from 0-100% in 10% increments. For example, 50% means the microwave system will remain on for five continuous seconds for every ten seconds during the cook cycle.

6. **Time**

Time can be set from 0 to 99 minutes. There are four time icons: the first lets the operator enter the time manually, while the others let the operator add time in 1-, 10-, or 60-second increments. Additionally, an X icon resets the cook time to 00:00.

7. **Cook**

Touch to cook.

Note: The oven may require additional warm-up time before cooking.

8. **Save to Menu**

If you want to save a manual mode setting into the oven menu, touch **Save to Menu**. All six events will be combined into a single menu recipe item, and the cook times for each event will be summed and divided into a single cook cycle.

a. Edit settings as needed by touching the setting you want to change. From this screen, the following settings are editable:

Note: For additional instructions for editing settings, see the [Info Mode](#).

- % Time
- % Air
- % Microwave
- Time
- Recipe Name

b. Touch **SAVE**.

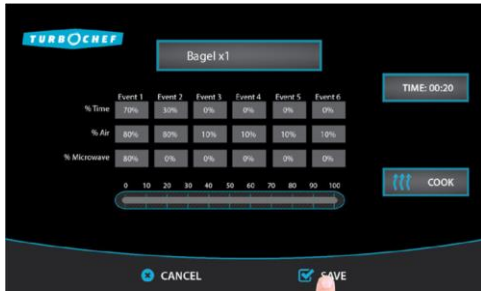

c. Select a group to select a location for the new menu item.

Note: To cancel, touch CANCEL.

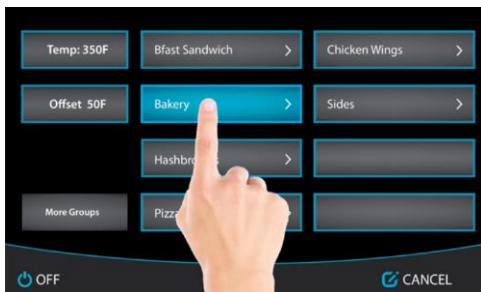

d. Select an item to overwrite.

Note: To cancel, touch CANCEL.

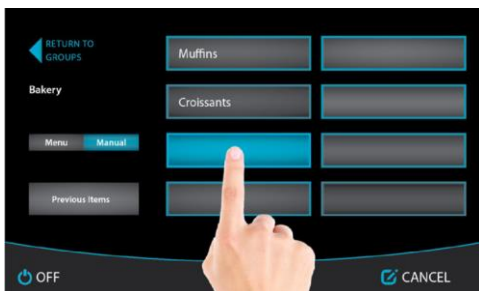

7.4 Info Mode

To access **INFO MODE** screen, touch the **i** icon when the oven is off, cooling down, or in manual mode.

7.4.1 Information Screen

- Serial Number
- Menu Version
- Sage Firmware
- Phoenix Firmware
- Service Number
- Measured VAC (incoming voltage)
- VAC
- **Tutorials:** View information on installing, operating, and maintaining the oven.

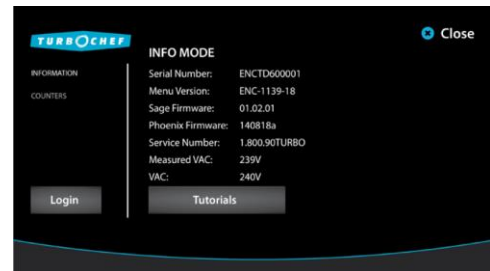

7.4.2 Counters Screen

- Cook Counter
- Total Cook Time
- Magnetron Time
- Total Time (oven on)
- **Power Cycles Count:** The number of times the oven has cycled through power

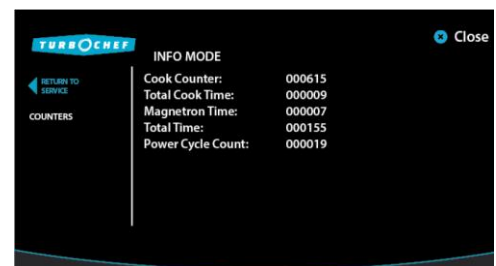

7.4.3 Options Screen

1. From **INFO MODE** or **COUNTERS** screen, touch **Login** to access the **OPTIONS** screen.
2. When prompted, enter the password 9 4 2 8.
3. Touch **ENTER**.

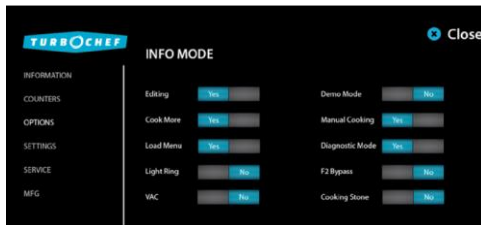

From the options screen, enable/disable:

- **Editing**
Edit Mode allows the operator to adjust menu settings, rename food groups and items, and change cooking temperatures. The Edit icon appears at the bottom of the screen when set to **Yes**.
- **Cook More**
Cook More controls whether the three **cook more** options appear when a cook cycle is done. This option must be enabled to cook an item beyond its original cook time.
- **Load Menu**
The load menu option enables or disables USB detection, allowing the operator to upload or download new menu settings from a USB device. Setting **Load Menu** to **No** prevents the operator from loading a menu.
- **Light Ring**
The light ring provides visual cues on oven operation and remaining cook time.
- **VAC**
The default is set to **Yes** so that the incoming voltage is displayed on the **INFO** screen.

- **Demo Mode**
Demo Mode is a feature that showcases the oven's cooking functions without activating the heaters or microwave system. Demo Mode must be set to **No** during normal operation.
- **Manual Cooking**
When Manual Cooking is set to **Yes**, the operator can cook items on the fly.
- **Diagnostic Mode**
Diagnostic Mode allows the operator to view and test oven components. This mode should be used only by qualified service technicians, unless otherwise instructed by TurboChef.
- **F2 Bypass**
The F2 alarm indicates that the oven temperature is too low. Selecting **Yes** means the oven will not stop the cooking cycle when an F2 alarm happens. The oven will still log the fault. **No** means the oven will stop the cooking cycle when an F2 alarm occurs.
- **Cooking Stone**
The Stone option should be set to:
 - **Yes**, if a baking stone is being used
Note: Selecting Yes increases the temperature of the oven's bottom half for optimal cooking results when using a stone. Changing this setting is not recommended, except for cook-setting developers, as it can adversely affect cook results.
 - **No**, if only a wire rack is being used

7.5 Settings Screen

1. From the **INFORMATION** or **COUNTERS** screen, touch **Login** to access the **Settings** screen.
2. When prompted, enter the password 9 4 2 8
3. Touch **ENTER**.

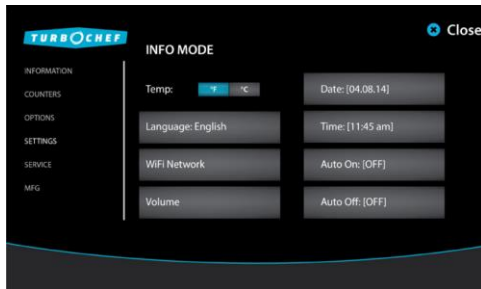

7.5.1 Temperature (F/C)

The temperature measurement setting is configured at the factory. Touch **°F** or **°C** to change the temperature measurement settings.

7.5.2 Language

The default language is English. To change to another language, touch **Language: English** and then touch the preferred language and touch **ENTER**. The available languages are:

- French
- German
- Polish
- Portuguese
- Russian
- Spanish

The available languages may also be:

- Chinese
- Korean
- Japanese

7.5.3 Wi-Fi/Network

If the oven is connected via Wi-Fi or Ethernet, connection status information will be displayed here. Wi-Fi credentials (if applicable) can also be entered or changed.

7.5.4 Sound Volume

Touch **Volume**, then use the plus or minus icons or the slider to increase or decrease the oven sound.

7.5.5 Set Date

Accurate timing is crucial for the auto-on and auto-off functions. It also ensures the precision of diagnostic and fault-condition reports.

Note: The oven may not retain the date if left unplugged for more than several hours.

1. To set the date, touch **Date**.
2. Enter the date in the following format - <MM/DD/YY>.
3. Touch **ENTER** to save the changes.

7.5.6 Set Time

Accurate timing is crucial for the auto-on and auto-off functions. It also ensures the precision of diagnostic and fault-condition reports.

Notes:

- *The oven might not retain the date if it's left unplugged for more than a few hours.*
- *The clock will not automatically adjust for Daylight Saving Time.*

1. To set the time, touch **Time**.
2. Enter the time in 24-hour format (8:30 p.m. = 20:30).
3. Touch **ENTER** to save the changes.

Note: The user interface will automatically convert the time to 12-hour format.

7.5.7 Auto On

Auto On is a feature that automatically turns on the oven at a specified time.

1. To set auto-on, ensure the time of day is accurate (adjacent and above).
2. Toggle the switch to the **Yes** position to enable.
3. Select the temperature.
4. Enter the time in 24-hour format.
5. Touch **SAVE** once complete.

Note: The time will automatically convert to 12-hour format when saved.



7.5.8 Auto Off

Auto off is a feature that automatically turns the oven off at a specified time.

1. To set auto-off time, ensure the time of day is accurate.
2. Toggle the **Yes/No** icon to the **No** position to enable.
3. Enter the time in 24-hour format.
4. Touch **SAVE** once complete.

Note: The time will automatically convert to 12-hour format when saved.

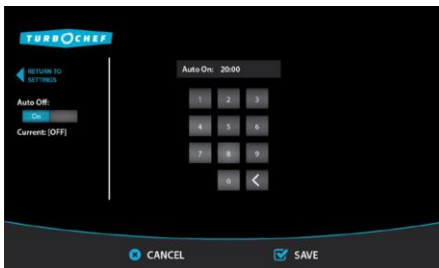

7.6 Edit Mode

Touch **Edit** to open the Edit screen. From this screen, the following options can be adjusted:

Note: If Edit is not an option, refer to the [Options Screen](#) section.

- [Edit Set Temperature](#)
- [Edit Bottom Temperature Offset](#)
- [Name a Group](#)
- [Delete a Group](#)
- [Move a Group](#)
- [Edit Item Settings](#)

7.6.1 Edit Set Temperature

Avoid adjusting the menu-set temperature to compensate for over- or undercooking. If the recipe settings do not produce the desired results, contact your menu developer, authorized distributor, or [Customer Support](#).

1. Touch **EDIT**.

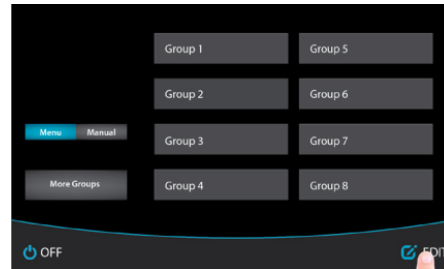

2. Touch the current set temperature.

Note: The set temperature will apply only to the groups adjacent to it. Be sure to check the temperature for groups 1-8 and for groups 9-16.



3. Enter the new set temperature. The temperature range is 300–600 °F (149–316 °C)

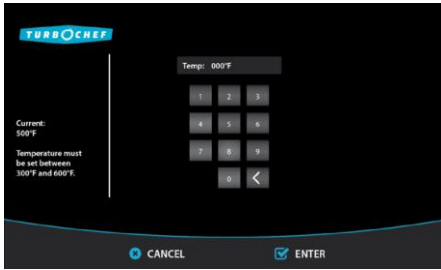

4. Touch **ENTER** to save the change.

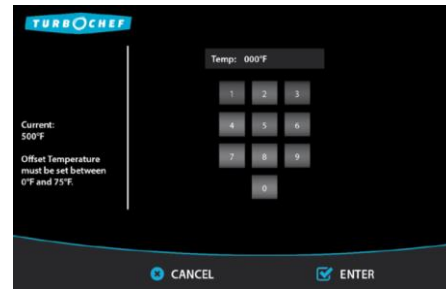

4. Touch **ENTER** to confirm the change

7.6.2 Edit Bottom Temperature Offset

The bottom temperature offset enables the bottom IR element to provide additional heat, resulting in deeper browning.

1. Touch **EDIT**.
2. Touch the current offset temperature or toggle at the bottom-left of the screen to switch between the two set temperatures if using two set temperatures.



7.6.3 Name a Group

1. Touch **EDIT**.
2. Select a group.



3. Select **Name Group**.

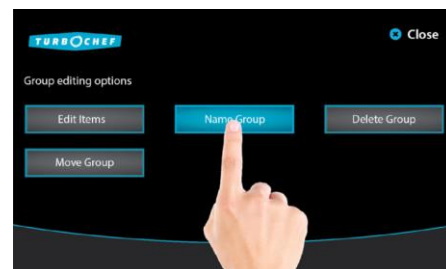

3. Enter the new offset temperature using the number keypad, ensuring it is between 0 and 75 in °F or °C.

Note: The temperature offset range is greater in °C.

4. Using the keypad, enter the new group name.
5. Touch **ENTER** to save the changes.



BULLET

6. Touch the 123 icon to access numbers and symbols.
7. Touch the arrow icon to change case between:
 - Uppercase
 - Lowercase
 - Caps lock

7.6.4 Delete a Group

1. Touch **EDIT**.
2. Touch the group to delete.



3. To delete a group, touch **Delete Group**.
Note: Deleting a group will delete all items in the group.

7.6.5 Move a Group

1. Touch **EDIT**.
2. Touch the **Group** to move.
3. Touch **Move Group**.

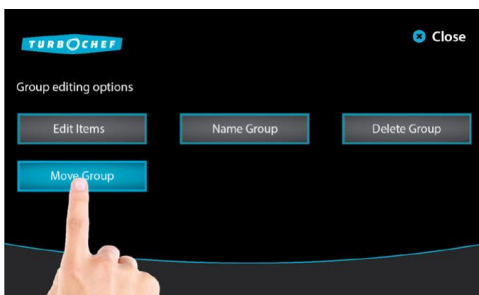

Note: The group that is to move will be highlighted in blue.

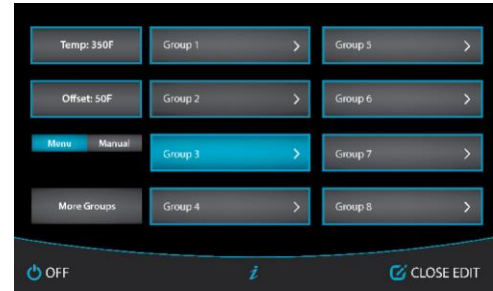

4. Touch the new location for the group.
Note: If a group is moved to a space that already contains settings; the old settings in that space will be overwritten.



7.7 Edit Item Settings

1. Touch **EDIT**.
2. Touch the group that contains the item to edit.
Note: Entering Edit Mode from the item selection screen rather than the group selection screen skips this step.
3. From the **Group editing options** screen, touch **Edit Items**.

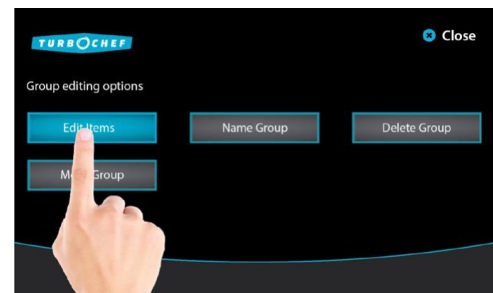

4. Touch an item to edit.

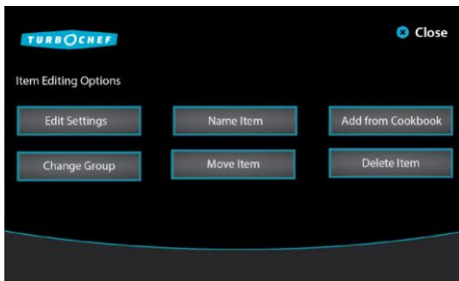

Edit % Time

1. Touch a % Time icon.



2. Enter the new percentage
3. Touch ENTER.



Note: % Time can be set from 0-100% for each event. The sum of all events must be 100.

Edit % Air

1. Touch a % Air icon
2. Use the sliding bar below the grid to make changes and adjustments.

Notes:

- % Air determines the amount of airflow. The more air, the more the product will brown or crisp.
- % Air can be set from 10-100% in 10% increments.

3. Touch **SAVE** once complete.



Edit % Microwave

1. Touch a % Microwave icon.
2. Use the sliding bar below the grid to make changes and adjustments.

Note: This can set from 0-100% in 10% increments. For example, 50% means the microwave system will remain on for five continuous seconds for every ten seconds during the cook cycle.

3. Touch **SAVE** once complete.



Edit Cook Time

1. Touch the current cook time.
2. Using the number keypad, enter the cook time.

Note: The maximum allowable cook time is 10:00.

3. Touch **ENTER**.
4. Touch **SAVE** once complete.

Run Test Cook Cycle

Touch Cook to perform a test cook.

Note: The oven may require additional warm-up time before a test cook can be performed.

7.7.1 Name an Item

1. Touch the current name.



2. Using the keypad, enter the name.
Note: The field allows for a maximum of 16 characters.
3. Touch **ENTER**.
4. Touch **SAVE** once complete.

7.7.2 Change Group

1. Select **Change Group**.
2. Select the desired group.



3. Select the space to move the group.
Note: If an item is moved to a space that already contains settings, the old settings will be overwritten.

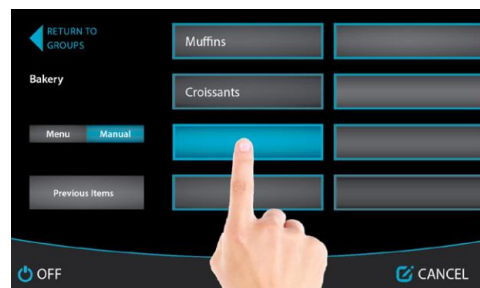

7.7.3 Move an Item

1. Select **Move Item**.
2. Select the desired item.



3. Select the space to move the item.
Note: If an item is moved to a space that already contains settings, the old settings will be overwritten.



2. The oven will automatically detect the device.
Touch **OK** to proceed.

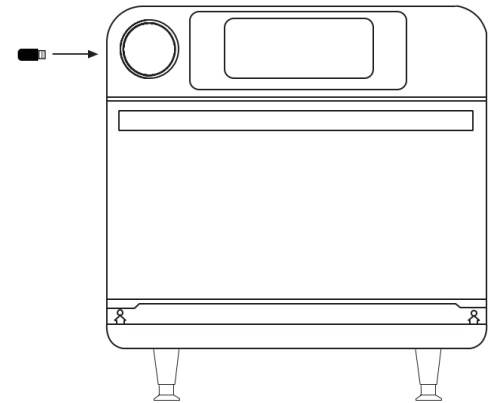

7.7.4 Delete an Item

1. Select **Delete Item**.
2. Select **OK**.

Note: Deleted items cannot be recovered.

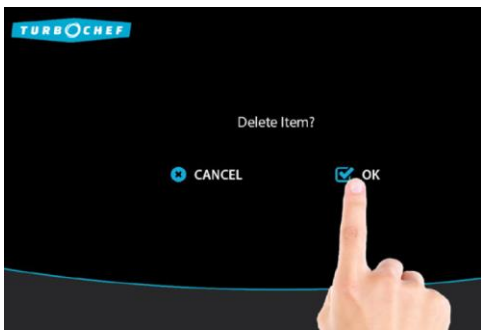

3. Touch **Load Menu to Oven**.

Note: When loading a menu from a USB drive, a copy of the current menu will be saved to the drive.



4. Touch **OK** to confirm the selection and begin the installation.

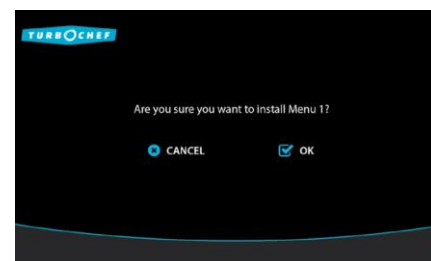

5. Touch the menu to load.

Note: If multiple menus are on the USB, the oven will display the menu names. Otherwise, this step will be bypassed.

7.8 Load Menu from USB

Note: To update the menu, ensure the Load Menu screen is enabled.

When loading from USB, the menu can be in XTM (ChefComm) or BIN (binary) format. The files must be loaded to the root of the USB drive. The oven will also detect menus stored in a folder named TC_Menus.

1. When the oven is off or cooling down, insert the USB.

- Once installation is complete, the oven will display **Installation Complete**.

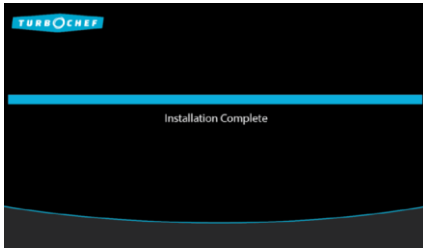

- Touch **CANCEL** to go back to the previous screen.

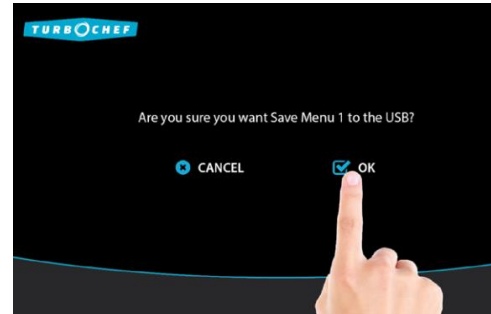

7.9 Save Menu to USB

Note: To save a copy of the oven menu, ensure the Load Menu screen is enabled.

- When the oven is off or cooling down, insert the USB.
- The oven will automatically detect the device. Touch **OK** to proceed.

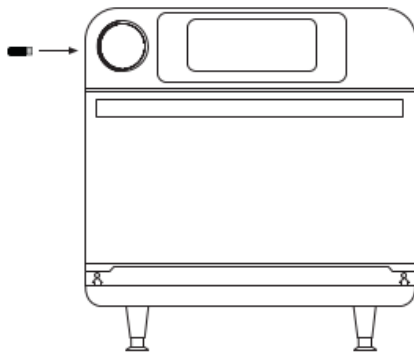

- Touch **Save Menu to USB**.

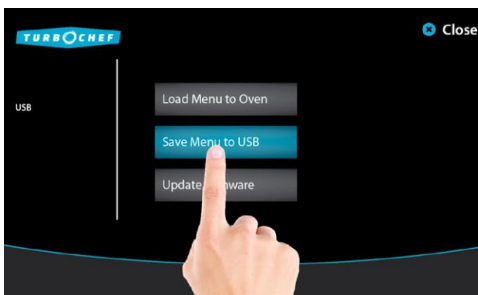

- Touch **OK** to begin saving the menu to the USB

- Once installation is complete, the oven will display **Save Complete**.

8. TROUBLESHOOTING

The following is a list of fault codes and error messages, along with the possible problem(s) the oven may experience. Attempt the recommended action before contacting [Customer Support](#) or your authorized distributor. If any fault or error message not listed below occurs, contact [Customer Support](#).

Note: Any fault codes listed in bold will terminate the cooking cycle upon detection. F6 will not terminate a cooking cycle; however, it will alert the user to a potential air circulation issue.

⚠ WARNING: Food, oven door, and oven cavity are hot! Use extreme caution when troubleshooting.

Issue	Possible Cause(s)	Resolution
No power to oven	Oven is not plugged in	Plug the oven in
	Main circuit breaker is tripped	<ol style="list-style-type: none"> 1. Verify the wall circuit breaker is on. 2. Reset the breaker. 3. Power the oven back on.
Oven is not warming up properly	Oven is in the Off state	Touch Menu and then set the temperature.
	Door is not closed	Close the cook cavity door.
	Oven has been switched off at the main circuit breaker	<ol style="list-style-type: none"> 1. Turn the oven off and unplug – leave for two minutes. 2. Replug in the oven. 3. Switch on the isolator/main power supply 4. Touch Menu and then set the temperature.
	High-limit thermostat tripped	Press the button on the rear wall of the oven (near the power cord) to reset the high-limit thermostat.
Display reads Oven Door Open and alarm sounds	Food obstruction is preventing the door from closing	Open the door and remove the obstruction.
	Oven door is open	Open and close the door several times.
	Door switches are out of alignment	Contact Customer Support .

TROUBLESHOOTING

Issue	Possible Cause(s)	Resolution
Oven is not cooking properly	Incorrect oven model specified.	From the Info Mode Manufacturing screen, ensure that the oven model is set to Bullet .
	Oven is not clean (large deposits of grease, carbon, or food debris dilute the microwave)	Clean the oven according to the Cleaning instructions .
	Incorrect group and/or item name was selected for the product	Ensure the correct food group and/or item was selected.
	Product was not cooked from correct starting state (e.g., chilled or frozen)	Ensure the product is in the correct state before being placed in the oven.
	Product out of specification	Ensure the product is the same eight/size as the typical product.
Steam or smoke is present	Oven is not clean (large deposits of grease, carbon, or food debris dilute the microwave)	Clean the oven according to the Cleaning instructions .
	Rear vent is clogged	Perform the Quarterly Maintenance .
Oven is cooling down, shutting down, or making selections on its own	Debris is on the display	Clean the display.
	RTD issue	Call for service.
Touch response is slow or not detecting touch	Bad boot up when the power was cycled	<ol style="list-style-type: none"> 1. Unplug the oven for 30 seconds. 2. Reconnect the oven and check if the problem has been fixed. 3. If not, contact Customer Support.

Issue	Possible Cause(s)	Resolution
F1: Blower Running Status Bad	Oven power interrupted	<ol style="list-style-type: none"> 1. Verify the wall circuit breaker is on. 2. Reset the breaker and then power on the oven. 3. Turn the oven off and unplug – leave for two minutes. 4. Replug in the oven 5. Switch on the isolator/main power supply. 6. Select Menu and then a set temperature.
F2: Cook Temperature Low	Oven power interrupted	Verify the wall circuit breaker is on. Reset the breaker and then power on the oven
	Air nozzles on the top/bottom of the cook cavity are clogged	During daily cleaning, ensure the air nozzles at the top/bottom of the cook cavity are unclogged.
	Oven door is out of alignment	Open and close the door several times, then verify that it is closed.
	Defective heater	Reset the high-limit thermostat on the rear wall of the oven, near the power cord.
	Blower motor not running	Contact Customer Support .
	Oven not fully warmed up	Repeat warmup and allow the oven to idle for five minutes.
F5: Magnetron Over Temperature OR F6: EC Temp Blockage of cool air into the oven	Blockage of cool air into the oven	Remove anything that may be obstructing the flow of cool air into the side/rear oven panels.
	Rear cooling fan exhaust guard(s) clogged	Make sure the rear fans are free of debris.

9. NORTH AMERICA LIMITED WARRANTY

The TurboChef Rapid Cook Oven Limited Warranty outlined below is activated upon shipment of your oven. Should you require additional assistance after reviewing the warranty outlined below, please call TurboChef Customer Support at 800.90TURBO.

9.1 Limited Warranty

TurboChef Technologies, LLC (“TurboChef”) warrants to you, the purchaser, that under normal use, the TurboChef rapid cook oven you have purchased (the “Equipment”) will be free from defects in material and workmanship during the Warranty Period, subject to the terms and conditions set forth herein. The “Warranty Period” is twelve (12) months from the date the Equipment is shipped from TurboChef’s U.S. factory or distribution center. This warranty is conditioned upon you promptly notifying TurboChef of any claims, as provided in the paragraph entitled “Warranty Claims” below, and providing TurboChef with all data and information requested by TurboChef or its service agents in connection with such claims as well as all necessary access to your premises and the Equipment. This warranty is made only to the initial purchaser of the Equipment from TurboChef or its authorized dealer; it is not assignable to subsequent purchasers unless TurboChef consents to such assignment in writing.

9.2 Disclaimer

Except as provided in the Limited Warranty above, the Equipment is provided “as-is”. TurboChef disclaims all other warranties, express, statutory, or implied, including, without limitation, the implied warranties of title, non-infringement, merchantability, and fitness for a particular purpose. TurboChef does not warrant that the Equipment will meet your specifications or needs. You acknowledge that you are solely responsible for selecting the Equipment and determining its suitability for your needs.

9.3 Warranty Exclusions

Improper Installation, Operation or Maintenance: Equipment that is not installed, operated and maintained in accordance with TurboChef’s rapid cook oven owner’s manual (as may be updated by TurboChef from time to time, the “Manual”), a copy of which is provided to you with the Equipment or otherwise will be furnished to you upon request, is excluded from this warranty. This warranty does not apply to damage or failure which results, in TurboChef’s or its service agent’s sole opinion, from failure to provide a suitable installation and operating environment (including power and HVAC) and facilities as prescribed by the Manual, misuse, abuse, accident, neglect, power failure or power surges (over or under voltage), or to damage or failure from flood, fire, lightning or other natural or man-made disasters, or other Acts of God, or to Equipment that has missing or altered serial numbers.

Modifications and Repair: Equipment that has been modified or altered by persons other than TurboChef or its service agents, or Equipment that has had non-approved devices or connection items attached thereto, is excluded from coverage under this warranty. Repair of the Equipment by anyone other than TurboChef or its authorized service agents will void all warranties on the Equipment.

Accessories: Accessories and parts (collectively "Accessories") that are consumed in the normal course of Equipment operation or maintenance are excluded from this warranty. Failure of or damage to Equipment or components from the use of non-approved cleaning chemicals, devices, or processes is also excluded from this warranty. Accessories may include, but are not limited to, ceramic cooking platters, paddles, and approved cleaning chemicals and devices.

Lower Jet Plate and Porcelain-coated Oven Components: Minor chipping of the porcelain is expected due to normal use. Replacement or repair for cosmetic defects and/or damage to porcelain-coated oven components, including but not limited to the lower jetplate, is excluded from this warranty.

Outstanding Invoices: If the full invoiced amount for Equipment purchased has not been paid within forty-five (45) days from the invoice date, then TurboChef will have no obligation to honor this or any other warranty on the Equipment until payment is received in full, including any accrued interest or other charges.

9.4 Warranty Service, Exclusive Remedy

TurboChef will be solely responsible for determining whether or not the Equipment or any component thereof is defective. Defective components covered by this warranty will be repaired or replaced at TurboChef's option without charge to you, and this warranty will cover such repaired or replacement components for the balance of the Warranty Period. Parts used in repairing defective components and replacing components may be new, recovered, or rebuilt. At its sole option, TurboChef may decide to replace defective Equipment covered by this warranty with new, recovered, or rebuilt Equipment of equal or greater capability, and such Equipment will be covered by this Limited Warranty for the balance of the Warranty Period. Defective Equipment and components will become the property of TurboChef. This paragraph states TurboChef's sole and exclusive obligation and liability and your sole and exclusive remedy under this warranty. TurboChef shall not be responsible for a failure to provide warranty services due to causes beyond TurboChef's or its service agents' control.

9.5 Warranty Claims

Claims under this warranty must be reported to TurboChef during our normal working hours at 800.90TURBO, or through another reporting service TurboChef designates. After receiving the claim and relevant information and conducting a preliminary verification that the claim is valid, TurboChef will promptly notify an authorized service agent to contact you and arrange an on-site repair visit during the agent's normal working hours. Any costs incurred by TurboChef or its service agent due to an inability to access the Equipment on your premises, or because this warranty does not cover a claim, will be charged to you.

9.6 Disclaimer of Damages

TurboChef disclaims all incidental, special and consequential damages, including but not limited to loss of use, lost revenue or profits, or substitute use, suffered by you or any third party, whether arising in contract, tort (including negligence), or otherwise, resulting from any breach by TurboChef or its service agents of this warranty, or resulting from the manufacture, use, or defects, of or in the Equipment, even if TurboChef was apprised of the possibility of such damages.

9.7 Customer Indemnity

You agree to indemnify, defend, and hold TurboChef harmless from all third-party claims, demands, judgments, fees, and costs directly or indirectly arising out of or related to your use of the Equipment. You further agree to indemnify and hold TurboChef harmless from any incidental, consequential, or special damages suffered by you, including lost revenue or profits, loss of use, or substitute use, during periods of Equipment failure or loss of use.

9.8 Territory

This warranty is valid in the United States of America, Canada, and Puerto Rico.

9.9 Governing Law, Entire Warranty

This warranty shall be governed and construed in accordance with the laws of the State of Texas, USA (except with respect to its provisions regarding conflicts of laws). The warranty described herein is the complete and only warranty for Equipment and supersedes all prior oral or written agreements and understandings that may have existed between us relating to Equipment warranties. The terms of this warranty may not be altered, amended, or modified except by a signed writing from TurboChef. Any purported alteration, amendment, or modification by a service agent or anyone else will not be enforceable against TurboChef.

9.10 Charges for Non-Warranty Service or Rejection of Service Visit

If repairs, replacement, or service are provided by TurboChef’s service agents for work not covered by this limited warranty, the customer agrees to pay the service agent directly at the service agent’s normal rate. In the event TurboChef is invoiced by the service agent for services not covered under this extended warranty, TurboChef will invoice the customer, and the customer will pay such invoice based on the terms of net 10 days. Customer also agrees to pay any costs incurred by TurboChef or its service agent associated with responding to a service call and then being refused or unable to gain access to the Oven on Customer’s premises. Failure to submit payment may, at TurboChef’s discretion, result in TurboChef voiding the balance of the warranty. In

10. INTERNATIONAL LIMITED WARRANTY

This Limited Warranty shall apply to the sales of all TurboChef Bullet ovens (the “Equipment”) manufactured by TurboChef Technologies, LLC (“TurboChef”), and sold to purchasers outside of the United States, Canada, Puerto Rico, Central and South America by an Authorized Distributor of TurboChef International (the “Authorized Distributor”).

10.1 Limited Warranty

You, the purchaser (“You”), have entered into a sales contract with the Authorized Distributor for the purchase of the Equipment. This Limited Warranty is made to you by the Authorized Distributor from whom you purchased the Equipment with the support of TurboChef. Subject to the limitations stated below, the Authorized Distributor warrants to You that the quantity and specification of the Equipment delivered to You shall be as set out in the Authorized Distributor’s acceptance of your order and that the Equipment will be free from any material defects in the product and workmanship for twelve (12) months from the date of installation (the “Warranty Period”), subject to the terms and conditions set forth herein.

10.2 Disclaimer

You acknowledge that You are solely responsible for selecting the Equipment and determining its suitability for Your needs. All other warranties, conditions or terms relating to fitness for purpose, quality or condition of the Equipment, whether expressed or implied by statute or common law or otherwise, are excluded to the fullest extent permitted by law.

10.3 The TurboChef Global Warranty System

This Limited Warranty commences upon delivery of the Equipment to Your premises. The Authorized Distributor will inspect and install the Equipment at Your premises in accordance with TurboChef’s instructions and will record the serial number of the Equipment, Your contact details, the date and location of installation, and the results of the Authorized Distributor’s inspection. The Authorized Distributor will enter this information into the TurboChef global warranty system and will use it by TurboChef, the Authorized Distributor, and its authorized service agents to provide warranty service.

10.4 Warranty Service

During the Warranty Period, TurboChef will repair or replace any significantly defective equipment free of charge, at its discretion, as long as you notify the Authorized Distributor who sold you the Equipment and/or TurboChef promptly after discovering the defect and follow the warranty claims process described below:

- You provide the Authorized Distributor from whom You purchased the Equipment and/or TurboChef with all data and information reasonably requested by TurboChef, the Authorized Distributor, or its authorized service agents in connection with your warranty claim;
- You make the Equipment available to TurboChef, the Authorized Distributor, or its authorized service agents;
- An Authorized Distributor has installed the Equipment, and you have provided all necessary information for the Authorized Distributor to register the Equipment in the TurboChef global warranty system;
- The Equipment has been operated and maintained by You in accordance with TurboChef's "Owner's Manual" provided with the Equipment (and as updated by TurboChef);
- You have not used any non-approved devices, accessories, consumables, or parts with the Equipment; and repairs, modifications, or alterations have not been attempted except by TurboChef, an Authorized Distributor, or its authorized service agent. Neither TurboChef nor the Authorized Distributor assumes liability for damage caused by Your failure to provide a suitable installation and operating environment (including power and HVAC) or facilities as outlined in the Manual, or due to misuse, abuse, accident, neglect, power failure, or power surges (over or under voltage), regardless of the cause. At its sole discretion, TurboChef may replace defective Equipment or parts with new, recovered, or rebuilt Equipment of equal or greater capacity, which the Authorized Distributor will warrant for the remaining Warranty Period. Replaced defective Equipment or components will become the property of TurboChef.

Warranty Claims: Any warranty claim must be made directly in writing either to the Authorized Distributor from whom You purchased the Equipment or to TurboChef at the following address:

TurboChef Technologies, LLC
2801 Trade Center Drive
Carrollton, Texas 75007
Phone: +1 214.379.6000
Fax: +1 214.379.6073

The claim must include the serial number of the Equipment and be received by TurboChef on or before the last day of the Warranty Period. Upon receipt of Your claim, TurboChef will promptly notify an Authorized Distributor or an authorized service agent to contact You, to verify Your claim and, if necessary, to arrange for an on-site repair visit during normal working hours.

Consumables and Parts Used with the Equipment: Neither TurboChef nor the Authorized Distributor assumes any liability for consumables and parts that are used in the normal course of Equipment operation or for failure of or damage to Equipment or components from the use of non-approved cleaning chemicals, devices, or processes.

Lower Jet Plate and Porcelain-Coated Oven Components: Minor chipping in the porcelain is expected with regular use. Replacement or repair for cosmetic defects and/or damage to porcelain-coated oven parts, including but not limited to the lower jet plate, is not covered by this warranty.

Charges for Service Not Covered by Limited Warranty: If You request and receive repairs, replacement or service not covered by this Limited Warranty, You will be invoiced and must pay the Authorized Distributor or authorized service agent directly according to its normal scale of charges and business terms.

Product Liability: Neither TurboChef nor the Authorized Distributor assumes any liability for incidental, special, or consequential damages, including but not limited to loss of use, revenue, profits, or substitute use incurred by You or any third party. This applies whether arising in contract, tort (including negligence), or otherwise resulting from any breach by TurboChef or the Authorized Distributor of the Limited Warranty provided herein.

Exclusive Remedy: This Limited Warranty states the Authorized Distributors and TurboChef's sole and exclusive obligation and liability and your sole and exclusive remedy under this Limited Warranty.

Third Party Rights: The UK Contract (Rights of Third Parties) Act 1999 does not apply to this Limited Warranty, and nothing in this document grants or claims to grant any third party any benefit or right to enforce any term of this Limited Warranty.

Severability: If any item or provision contained in this Limited Warranty or any part of them ("an offending provision") is declared to be or becomes unenforceable, invalid or illegal for any reason whatsoever in any jurisdiction, the other terms and provisions of this Limited Warranty shall remain in full force and effect in that jurisdiction as if it had been executed without the offending provision appearing in it and the entire Limited Warranty shall remain in full force and effect in all other jurisdictions.

Governing Law, Entire Agreement: This Limited Warranty shall be governed by and construed according to English law.

For service or information:
WITHIN NORTH AMERICA CALL
Customer Support at 800.90TURBO
OUTSIDE NORTH AMERICA CALL
+1 214.379.6000 or Your Authorized Distributor



Country Code: NA/EU

<i>Global Operations</i>	<i>TurboChef International</i>	<i>Customer Support</i>
2801 Trade Center Drive	Business & Technology	800.90TURBO
Carrollton, Texas 75007 USA	Centre	+1 214.379.6000
+1 214.379.6000 phone	Bessemer Drive	turbochef.com
+1 214.379.6073 fax	Stevenage	
	Herts SG1 2DX	
	United Kingdom	
	+44 8456021544 phone	
	+44 8456021636 fax	