



# Installation, Operation, and Maintenance

## **Blower Coil Air Handler**

### Air Terminal Devices, 400 - 3000 CFM



Models BCHD, BCVD, and BCCD "LO" and later design sequence

#### **⚠ SAFETY WARNING**

Only qualified personnel should install and service the equipment. The installation, starting up, and servicing of heating, ventilating, and air-conditioning equipment can be hazardous and requires specific knowledge and training. Improperly installed, adjusted or altered equipment by an unqualified person could result in death or serious injury. When working on the equipment, observe all precautions in the literature and on the tags, stickers, and labels that are attached to the equipment.



# Introduction

Read this manual thoroughly before operating or servicing this unit.

## Warnings, Cautions, and Notices

Safety advisories appear throughout this manual as required. Your personal safety and the proper operation of this machine depend upon the strict observance of these precautions.

The three types of advisories are defined as follows:

**⚠ WARNING** Indicates a potentially hazardous situation which, if not avoided, could result in death or serious injury.

**⚠ CAUTION** Indicates a potentially hazardous situation which, if not avoided, could result in minor or moderate injury. It could also be used to alert against unsafe practices.

**NOTICE** Indicates a situation that could result in equipment or property-damage only accidents.

## Important Environmental Concerns

Scientific research has shown that certain man-made chemicals can affect the earth's naturally occurring stratospheric ozone layer when released to the atmosphere. In particular, several of the identified chemicals that may affect the ozone layer are refrigerants that contain Chlorine, Fluorine and Carbon (CFCs) and those containing Hydrogen, Chlorine, Fluorine and Carbon (HCFCs). Not all refrigerants containing these compounds have the same potential impact to the environment. Trane advocates the responsible handling of all refrigerants-including industry replacements for CFCs and HCFCs such as saturated or unsaturated HFCs and HCFCs.

## Important Responsible Refrigerant Practices

Trane believes that responsible refrigerant practices are important to the environment, our customers, and the air conditioning industry. All technicians who handle refrigerants must be certified according to local rules. For the USA, the Federal Clean Air Act (Section 608) sets forth the requirements for handling, reclaiming, recovering and recycling of certain refrigerants and the equipment that is used in these service procedures. In addition, some states or municipalities may have additional requirements that must also be adhered to for responsible management of refrigerants. Know the applicable laws and follow them.

### ⚠ WARNING

#### Proper Field Wiring and Grounding Required!

Failure to follow code could result in death or serious injury. All field wiring **MUST** be performed by qualified personnel. Improperly installed and grounded field wiring poses **FIRE** and **ELECTROCUTION** hazards. To avoid these hazards, you **MUST** follow requirements for field wiring installation and grounding as described in **NEC** and your local/state electrical codes.

### ⚠ WARNING

#### Personal Protective Equipment (PPE) Required!

Failure to wear proper PPE for the job being undertaken could result in death or serious injury. Technicians, in order to protect themselves from potential electrical, mechanical, and chemical hazards, **MUST** follow precautions in this manual and on the tags, stickers, and labels, as well as the instructions below:

- Before installing/servicing this unit, technicians **MUST** put on all PPE required for the work being undertaken (Examples; cut resistant gloves/sleeves, butyl gloves, safety glasses, hard hat/bump cap, fall protection, electrical PPE and arc flash clothing). **ALWAYS** refer to appropriate Safety Data Sheets (SDS) and OSHA guidelines for proper PPE.
- When working with or around hazardous chemicals, **ALWAYS** refer to the appropriate SDS and OSHA/GHS (Global Harmonized System of Classification and Labeling of Chemicals) guidelines for information on allowable personal exposure levels, proper respiratory protection and handling instructions.
- If there is a risk of energized electrical contact, arc, or flash, technicians **MUST** put on all PPE in accordance with OSHA, NFPA 70E, or other country-specific requirements for arc flash protection, **PRIOR** to servicing the unit. **NEVER PERFORM ANY SWITCHING, DISCONNECTING, OR VOLTAGE TESTING WITHOUT PROPER ELECTRICAL PPE AND ARC FLASH CLOTHING. ENSURE ELECTRICAL METERS AND EQUIPMENT ARE PROPERLY RATED FOR INTENDED VOLTAGE.**

**⚠ WARNING****Follow EHS Policies!**

Failure to follow instructions below could result in death or serious injury.

- **All Trane personnel must follow the company's Environmental, Health and Safety (EHS) policies when performing work such as hot work, electrical, fall protection, lockout/tagout, refrigerant handling, etc. Where local regulations are more stringent than these policies, those regulations supersede these policies.**
- **Non-Trane personnel should always follow local regulations.**

## Copyright

This document and the information in it are the property of Trane, and may not be used or reproduced in whole or in part without written permission. Trane reserves the right to revise this publication at any time, and to make changes to its content without obligation to notify any person of such revision or change.

## Trademarks

All trademarks referenced in this document are the trademarks of their respective owners.

## Revision History

Running changes included.



# Table of Contents

Model Number Description	5	Wireless Sensor Specifications	57
General Information	7	Agency Compliance	58
Pre-Installation	9	Wireless Display Sensor (WDS)	58
Receiving and Handling	9	Installation - Electrical	62
Jobsite Storage	9	Unit Wiring Diagrams	62
Site Preparation	10	Supply Power Wiring	62
Dimensions and Weights	11	Electrical Grounding Restrictions	62
Service Clearances	11	Interconnection Wiring	63
Horizontal Blower Coil	12	MCA and MOP Calculations	63
Vertical Blower Coil	13	ECM Overview and Setup	66
Compact Vertical Blower Coil	14	Trane Electronically Commutated Motor (ECM)	66
Coil Connections	23	VelociTach™ Motor Control Board	67
Piping Packages	23	Installation and Initial Setup	67
Installation - Mechanical	28	Adjustments	73
Lifting and Rigging	28	Configurations	76
Installation Procedure	28	Start-Up	81
Piping and Connections	32	Pre-Startup Checklist	81
General Recommendations	32	Unit Startup	82
Drain Pan Trapping (Models BCHD/BCVD)	33	Thermostat	82
Steam Coil Piping	34	Tracer® ZN520 Controllers	84
Water Coil Piping	35	Tracer® UC400-B Controller	93
Refrigerant Coil Piping	36	Routine Maintenance	100
Liquid Lines	37	Maintenance Checklist	100
Suction Lines	38	Air Filters	100
Expansion Valves	38	Fans	100
Remodel, Retrofit, or Replacement	38	Coils	105
Field-Installed Evaporator Piping	40	Drain Pans	107
Installation - Controls	41	Diagnostics and Troubleshooting	108
Control Options	41	Wireless Zone Sensors (WZS)	109
Thermostat	44	Servicing and Testing WZS	114
Tracer® ZN520 Controller	45	Thermostat	115
Tracer® UC400-B Controller	46	Tracer® ZN520 Controllers	116
Air-Fi® Wireless Communications Systems	49	Tracer® UC400-B Controller	122
Zone Sensor Options	51	ECM Motors	128
Zone Sensor Installation	52	Wiring Diagrams	134
Zone Sensor Settings	54	Layout and Control Box Diagrams	135
Sensor Operations	56		



# Model Number Description

Following is a complete description of the blower coil model number. Each digit in the model number has a corresponding code that identifies specific unit options.

## Digits 1, 2, 3, 4 – Unit Model

BCHD = Horizontal blower coil  
 BCVD = Vertical blower coil  
 BCCD = Compact vertical unit

## Digits 5, 6, 7 – Unit Size

012 = Unit size 12 - 1 Ton  
 018 = Unit size 18 - 1 1/2 Ton  
 024 = Unit size 24 - 2 Ton  
 036 = Unit size 36 - 3 Ton  
 048 = Unit size 48 - 4 Ton  
 054 = Unit size 54 - 4 1/2 Ton  
 060 = Unit size 60 - 5 Ton  
 072 = Unit size 72 - 6 Ton  
 090 = Unit size 90 - 7 1/2 Ton

## Digit 8 – Unit Voltage

A = 115V/60 Hz/1 PH  
 B = 208V/60 Hz/1 PH  
 C = 230V/60 Hz/1 PH  
 D = 277V/60 Hz/1 PH  
 E = 208V/60 Hz/3 PH  
 F = 230V/60 Hz/3 PH  
 G = 460V/60 Hz/3 PH  
 J = 220V/50 Hz/1 PH  
 K = 240V/50 Hz/1 PH  
 L = 380V/50 Hz/3 PH  
 M = 415V/50 Hz/3 PH

## Digit 9 – Insulation

1 = Matte faced insulation 1-in.  
 2 = Foil faced insulation 1-in.

## Digits 10, 11 – Design Sequence

\*\*\* = Factory assigned

## Digit 12 – Motor and Control Box Location

A = Same side as coil connections horizontal or vertical counterclockwise only  
 B = Opposite side of coil connections horizontal or vertical counterclockwise only  
 C = Same side as coil connections vertical clockwise only  
 D = Opposite side of coil connections vertical clockwise only  
 E = Front return (BCCD only)  
 F = Front return with grill (BCCD only)  
 G = Bottom return (BCCD only)

## Digit 13 – Coil Connection Side

0 = None  
 1 = PVC drain pan right hand coil  
 2 = PVC drain pan left hand coil  
 3 = SS drain pan right hand coil  
 4 = SS drain pan left hand coil  
 5 = PVC drain pan front connection  
 6 = SS drain pan front connection

## Digit 14 – Coil #1 First Coil in Air Stream

0 = No Coil #1  
 A = 1-row hydronic preheat  
 F = 4-row hydronic  
 G = 6-row hydronic  
 J = 4-row hydronic with auto change over  
 K = 6-row hydronic with auto change over  
 L = 2-row high capacity hydronic preheat  
 M = 4-row high capacity hydronic  
 N = 6-row high capacity hydronic  
 R = 4-row high capacity hydronic with auto change over  
 T = 6-row high capacity hydronic with auto change over  
 1 = 3-row DX 3/16-in. (0.032) Dist  
 2 = 4-row DX 3/16-in. (0.032) Dist  
 3 = 6-row DX 3/16-in. (0.032) Dist  
 4 = 3-row DX 3/16-in. (0.049) Dist  
 5 = 4-row DX 3/16-in. (0.049) Dist  
 6 = 6-row DX 3/16-in. (0.049) Dist  
 7 = 4-row DX 3/16-in. (0.049) Dist, heat pump  
 8 = 6-row DX 3/16-in. (0.049) Dist, heat pump

## Digit 15 – Coil #2 Second Coil in Air Stream

0 = No coil #2  
 A = 1-row hydronic reheat  
 F = 4-row hydronic  
 G = 6-row hydronic  
 J = 4-row hydronic with auto change over  
 K = 6-row hydronic with auto change over  
 L = 2-row high capacity hydronic reheat  
 M = 4-row high capacity hydronic  
 N = 6-row high capacity hydronic  
 R = 4-row high capacity hydronic with auto change over  
 T = 6-row high capacity hydronic with auto change over  
 1 = 3-row DX 3/16-in. (0.032) Dist  
 2 = 4-row DX 3/16-in. (0.032) Dist  
 3 = 6-row DX 3/16-in. (0.032) Dist  
 4 = 3-row DX 3/16-in. (0.049) Dist  
 5 = 4-row DX 3/16-in. (0.049) Dist  
 6 = 6-row DX 3/16-in. (0.049) Dist  
 7 = 4-row DX 3/16-in. (0.049) Dist, heat pump  
 8 = 6-row DX 3/16-in. (0.049) Dist, heat pump

## Digit 16 – Motor Horsepower

2 = 1/2 Horsepower  
 4 = 1 Horsepower  
 5 = 1.5 Horsepower  
 7 = 3 Horsepower

## Digit 17 – Motor Speed

A = 500 rpm  
 B = 600 rpm  
 C = 700 rpm  
 D = 800 rpm  
 E = 900 rpm

F = 1000 rpm  
 G = 1100 rpm  
 H = 1200 rpm  
 J = 1300 rpm  
 K = 1400 rpm  
 L = 1500 rpm  
 M = 1600 rpm  
 N = 1700 rpm  
 P = 1800 rpm  
 R = 1900 rpm  
 T = 2000 rpm  
 U = 2100 rpm  
 V = 2200 rpm  
 W = 2300 rpm  
 Z = TOPSS base performance

## Digit 18 – Electric Heat Stages

0 = None  
 1 = 1-stage  
 2 = 2-stage

## Digits 19, 20, 21 – Electric Heat kW

010 = 1.0 kW  
 015 = 1.5 kW  
 020 = 2.0 kW  
 025 = 2.5 kW  
 030 = 3.0 kW  
 035 = 3.5 kW  
 040 = 4.0 kW  
 045 = 4.5 kW  
 050 = 5.0 kW  
 055 = 5.5 kW  
 060 = 6.0 kW  
 065 = 6.5 kW  
 070 = 7.0 kW  
 075 = 7.5 kW  
 080 = 8.0 kW  
 090 = 9.0 kW  
 100 = 10.0 kW  
 110 = 11.0 kW  
 000 = None  
 120 = 12.0 kW  
 130 = 13.0 kW  
 140 = 14.0 kW  
 150 = 15.0 kW  
 160 = 16.0 kW  
 170 = 17.0 kW  
 180 = 18.0 kW  
 190 = 19.0 kW  
 200 = 20.0 kW  
 210 = 21.0 kW  
 220 = 22.0 kW  
 240 = 24.0 kW  
 260 = 26.0 kW  
 280 = 28.0 kW  
 300 = 30.0 kW

## Digit 22 – Electric Heat Controls

0 = None  
 A = 24 volt magnetic contactors

## Digit 23 – Electric Heat Options

A = Heater fuse  
 B = Interlocking disconnect switch  
 C = Interlock disc and heater fuse  
 0 = None

## Digit 24 – Filters

A = 1-in. throwaway



## Model Number Description

- B = 2-in. MERV 8 pleated throwaway
- C = 2-in. MERV 13 pleated throwaway
- 0 = None

### Digit 25 – Accessory Section

- A = Mixing box only
- B = Angle filter box
- C = Angle filter/mix box
- D = Top access filter module
- E = Bottom access filter module
- F = Top access filter and mix box
- G = Bottom access filter and mix box
- H = Steam coil module
- J = Steam coil module and mix box
- K = Steam coil module and angle filter box
- L = Steam coil module and angle filter /mix box
- M = Steam coil module and top access filter module
- N = Steam coil module and bottom access filter module
- P = Steam coil module and top access filter module and mix box
- R = Steam coil module and bottom access filter module and mix box
- 0 = None

### Digit 26 – Control Type

- N = CSTI Fan Status
- 1 = Customer Supplied Terminal Interface (CSTI)
- 4 = Tracer<sup>®</sup> ZN520
- 6 = No controls (FSS)
- 8 = UC 400-B
- 9 = UC 400-B and WCI
- P = Thermostat

### Digit 27 – Coil #1 Control Valve Type

- 0 = None
- A = 2-way, 2-position N.C.
- B = 2-way, 2-position N.O.
- C = 3-way, 2-position N.C.
- D = 3-way, 2-position N.O.
- E = 2-way, modulating
- F = 3-way, modulating
- G = Field supplied valve, 2-position N.C.
- H = Field supplied valve, 2-position N.O.
- J = Field supplied valve, modulating
- K = Field supplied valve, analog (2-10 VDC)

### Digit 28 – Coil #1 Control Valve Cv

- 0 = None
- V = 2-way 2.3 Cv 3/4-in. valve and pipe
- W = 2-way 3.3 Cv 3/4-in. valve and pipe
- Y = 2-way 4.6 Cv 3/4-in. valve and Pipe
- Z = 2-way and 3-way 7.4 Cv 1-in. and pipe
- 1 = 2-way and 3-way 10.0 Cv 1-in. valve, 1 1/4-in. pipe
- 2 = 3-way 1.0 Cv 1/2-in. valve, 3/4-in. pipe
- 3 = 3-way 2.7 Cv 1/2-in. valve, 3/4-in. pipe

- 4 = 3-way 4.6 Cv 3/4-in. valve and pipe

### Digit 29 – Coil #1 Piping Package

- 0 = None
- 1 = Basic piping package
- 2 = Deluxe piping package

### Digit 30 – Coil #2 Control Valve

- 0 = None
- A = 2-way, 2-position N.C.
- B = 2-way, 2-position N.O.
- C = 3-way, 2-position N.C.
- D = 3-way, 2-position N.O.
- E = 2-way, modulating
- F = 3-way, modulating
- G = Field supplied valve, 2-position N.C.
- H = Field supplied valve, 2-position N.O.
- J = Field supplied valve, modulating
- K = Field supplied valve, analog (2-10 VDC)

### Digit 31 – Coil #2 Control Valve Cv

- 0 = None
- V = 2-way 2.3 Cv 3/4-in. valve and pipe
- W = 2-way 3.3 Cv 3/4-in. valve and pipe
- Y = 2-way 4.6 Cv 3/4-in. valve and pipe
- Z = 2-way and 3-way 7.4 Cv 1-in. and pipe
- 1 = 2-way and 3-way 10.0 Cv 1-in. valve, 1 1/4-in. pipe
- 2 = 3-way 1.0 Cv 1/2-in. valve, 3/4-in. pipe
- 3 = 3-way 2.7 Cv 1/2-in. valve, 3/4-in. pipe
- 4 = 3-way 4.6 Cv 3/4-in. valve and pipe

### Digit 32 – Coil #2 Piping Package

- 0 = None
- 1 = Basic piping package
- 2 = Deluxe piping package

### Digit 33 – Remote Heat Options

- 0 = None
- 1 = Remote staged electric heat
- 2 = Remote 2-position hot water, N.C.

### Digit 34 – Mixing Box Damper Actuator

- 1 = 2-position, N.O., ship loose
- 2 = Modulating, N.C.
- 3 = Modulating, N.O.
- 4 = Modulating, ship loose
- 5 = Field supplied, 2-position N.O.
- 6 = Field supplied, 2-position N.C.
- 7 = Field supplied modulating
- 0 = None

### Digit 35 – Factory Mounted Control Options

- C = Condensate overflow
- D = Low limit

- K = Condensate overflow and low limit
- 0 = None

### Digit 36 – Control Options 2

- A = Outside air sensor, field-mounted
- B = Discharge air sensor
- C = Outside air and discharge air sensor
- 0 = None

### Digit 37 – Control Options 3

- A = Dehumidification with communicated value
- B = Dehumidification with local sensor
- C = CO<sub>2</sub> Sensor
- D = Air-Fi<sup>®</sup> Dehumidification and CO<sub>2</sub>
- E = Air-Fi<sup>®</sup> Dehumidification
- F = Air-Fi<sup>®</sup> CO<sub>2</sub>
- 0 = None

### Digit 38 – Zone Sensors

- 1 = Wall-mounted temperature sensor (SP, OA, OCC/UNOCC, COMM)
- 3 = Wall-mounted temperature sensor (SP, OCC/UNOCC, COMM)
- 4 = Wall-mounted temperature sensor (OCC/UNOCC, COMM)
- C = Wireless temperature sensor, unit-mounted receiver
- E = Wall-mounted temperature sensor (SP, OALMH, OCC/UNOCC, COMM)
- F = Wall-mounted display sensor (SP, OALHH, COMM)
- G = Wireless display sensor, unit-mounted receiver (SP, OALMH)
- H = Wall-mounted FSS
- 0 = None
- A = Wall-mounted

### Digit 39 – Seismic Certification

- 0 = None
- A = IBC seismic certification
- B = OSHPD seismic certification
- C = LEED wrap
- D = LEED wrap IBC seismic certification
- E = LEED wrap OSHPD seismic certification

### Digit 40 – Extra Filter

- 0 = None
- 1 = Extra 1-in. throwaway ship loose
- 2 = Extra 2-in. MERV 8 pleated throwaway ship loose
- 3 = Extra 2-in. MERV 13 pleated throwaway ship loose



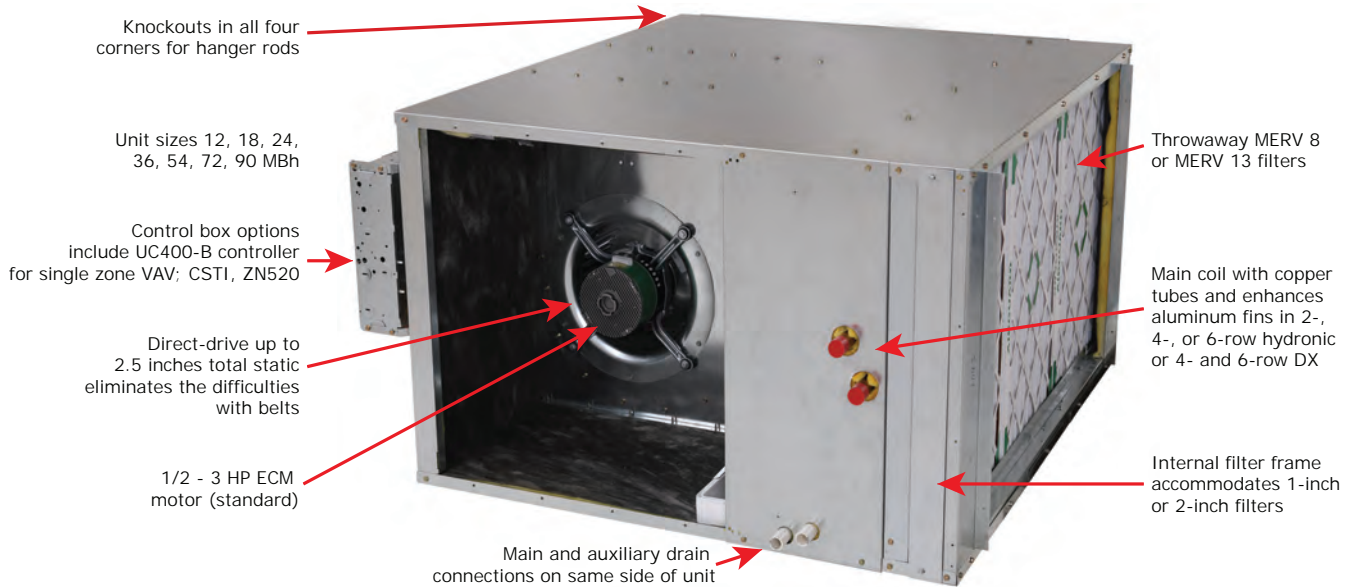
# General Information

Blower coil units are draw-thru air handlers for cooling load conditions of 400–3000 cfm. Units are available in horizontal (model BCHD), vertical (model BCVD), and compact vertical (model BCCD) configurations. Horizontal units are typically ceiling suspended via threaded rods. Knockouts are provided in all four corners to pass the rods through the unit. Horizontal units can also be floor mounted. Vertical units are typically floor mounted. They have a side inlet for easy duct connection, and do not

require a field fabricated inlet plenum. Vertical units ship in two pieces and can be set up in either a pre-swirl or counter-swirl configuration. Compact vertical units are floor mounted and ship in one piece.

Basic unit components consist of a coil, condensate drain pan, filter, duct collars, one fan wheel, and an electronically commutated motor (ECM).

**Figure 1. Blower coil air handler unit components (model BCHD, horizontal unit)**



Four-row or six-row main coils are available for either hydronic cooling or heating. Three, four, or six-row direct expansion (DX) coils are also available for cooling. An optional one-row or two-row heating coil is available factory-installed in either the preheat or reheat position. Also, a one-row preheat steam is available.

All units have an internal flat filter frame for one or two-inch filters. An optional angle filter box (two inch only), mixing box, bottom/top filter access box, or combination angle filter mixing box is available.

In addition, all units are available with either a basic or deluxe piping package option that includes a variety of control valve sizes in two or three-way configurations. The basic package consists of a control valve and stop (ball) valves. The deluxe package consists of a control valve, a circuit setter, and strainer.

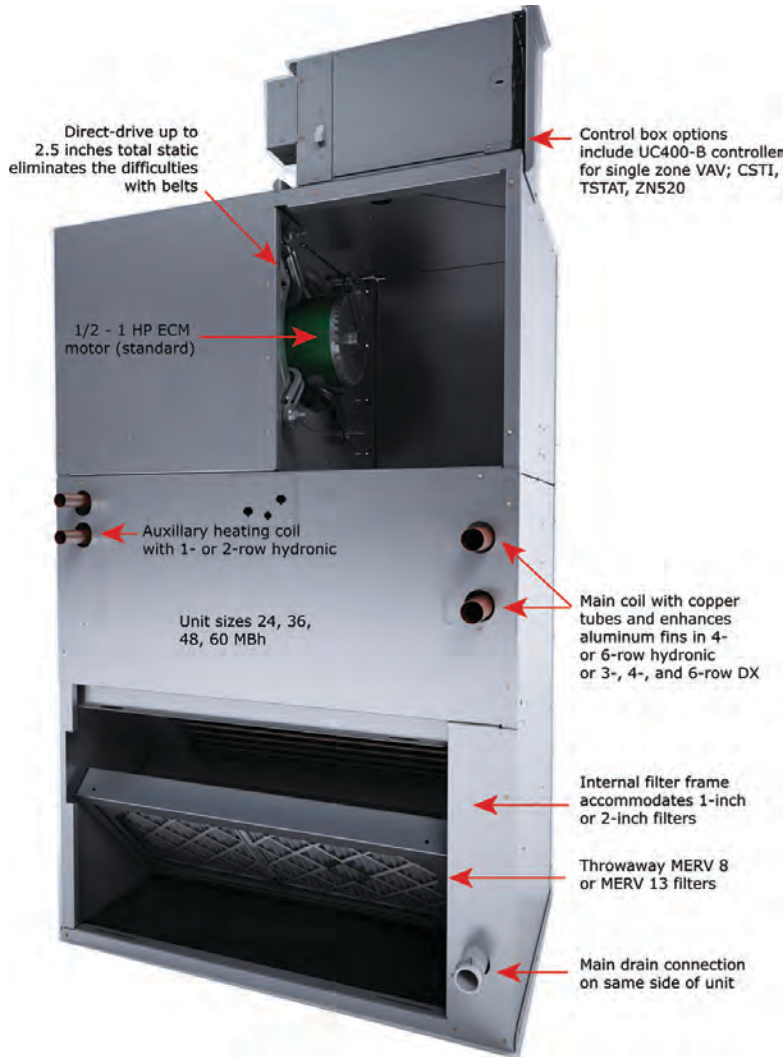
Direct-drive motors range from 1/2 to 3 horsepower in a wide range of voltages. All motors have internal current overload protection, permanently sealed ball bearings, and rubber grommets on the mounting brackets to reduce noise and vibration transmission.

Motors come factory programmed for specific job requirements or can be programmed based on standardized motor speeds. Field adjustment of motor speeds can be adjusted through the VelociTach™ motor control board. This enables the unit to be easily balanced for changes to design static pressures. Refer to the original sales order and the motor control board label on the unit for the programmed motor speed. Several factory-installed and tested control options are available.



## General Information

Figure 2. Compact vertical blower coil (BCCD model)





# Pre-Installation

## Receiving and Handling

### Inspection

Upon delivery, thoroughly inspect all components for any shipping damage that may have occurred, and confirm that the shipment is complete.

**Note:** *Delivery cannot be refused. All units are shipped F.O.B. factory. Trane is not responsible for shipping damage.*

### Packaging/Shipping

Blower coil units ship assembled on skids with protective coverings over the coil and discharge openings.

Field-installed sensors ship separately inside the unit's main control panel. Piping packages and mixing boxes are packaged separately and ship on the same skid as the unit.

### Identification

Each unit includes a nameplate identifying the section type and functional components, customer tagging information, unit serial number, unit order number, the build-section position for installation, and the unit model number.

### Handling

The unit ships on skids that provide forklift locations from the front or rear. The skid allows easy maneuverability of the unit during storage and transportation. Trane recommends leaving units and accessories in their shipping packages/skids for protection and handling ease until installation. Remove the skids using a forklift or jack before placing the unit in its permanent location.

### Receiving Checklist

Complete the following checklist immediately after receiving shipment to detect possible shipping damage.

- Check to ensure that the shipment is complete. Small components may ship inside the unit or ship separately. Check the parts list to ensure all materials are present. If any component is missing, contact your local Trane sales office.
- Check all units, components, connections, and piping. Check fan wheel for free rotation by spinning manually. Check all doors, latches and hinges. Inspect interior of each unit or section. Inspect coils for damage to fin surface and coil connections. Check for rattles, bent corners, or other visible indications of shipping damage. Tighten loose connections.
- If a unit is damaged, make specific notations concerning the damage on the freight bill. Do not refuse delivery.

- Notify the carrier's terminal of the damage immediately by phone and mail. Request an immediate joint inspection of the damage by the carrier and consignee.
- Notify your Trane sales representative of the damage and arrange for repair. Do not attempt to repair the unit without consulting the Trane representative.
- Inspect the unit for concealed damage as soon as possible after delivery. Report concealed damage to the freight line. It is the receiver's responsibility to provide reasonable evidence that concealed damage did not occur after delivery. Take photos of damaged material if possible.

**Note:** *Concealed damage must be reported within 15 days of receipt.*

## Jobsite Storage

This unit is intended for indoor use only. It is the sole responsibility of the customer to provide the necessary protection to prevent vandalism and weather protection of the equipment. Under no circumstance should the unit be left unprotected from the elements.

### NOTICE

#### Microbial Growth!

**Failure to follow instructions below could result in odors and damage to the equipment and building materials.**

**The floor or foundation must be level and the condensate drain at the proper height for proper drainage and condensate flow. Standing water and wet surfaces inside the equipment can become an amplification site for microbial growth (mold). If there is evidence of microbial growth on the interior insulation, it should be removed and replaced prior to operating the system.**

## Outdoor Storage

Outdoor storage is **not** recommended. However, when indoor storage is not possible, Trane makes the following recommendations to prevent damage:

**Note:** *Keep the equipment on the original wooden blocks/skid for protection and ease of handling.*

- Select a well-drained area, preferably a concrete pad or blacktop surface.
- Place the unit on a dry surface or raised off the ground to assure adequate air circulation beneath the unit and to assure no portion of the unit will contact standing water at any time.
- Cover the unit securely with a canvas tarp.



## Pre-Installation

### NOTICE

#### Corrosion!

**Use only canvas tarps to cover unit. Plastic tarps can cause condensation to form in and on the equipment, which could result in corrosion damage or wet storage stains.**

- Do not stack units.
- Do not pile other material on the unit.

### Site Preparation

- Ensure the installation site can support the total weight of the unit. Refer to the unit submittals for actual weights.
- Allow sufficient space for adequate free air and necessary service access. Refer to submittals for specific minimums.
- Allow room for supply and return piping, ductwork, electrical connections, and coil removal. Support all piping and ductwork independently of the unit to prevent excess noise and vibration.
- Ensure there is adequate height for coil piping and condensate drain requirements.
- Consider coil piping and condensate drain requirements. Verify condensate line is continuously pitched one inch per 10 feet of condensate line run to adequately drain condensate.
- Confirm the floor or foundation is level. For proper unit operation, the unit must be level (zero tolerance) in both horizontal axis.

### NOTICE:

#### Microbial Growth!

**Failure to follow instructions below could result in odors and damage to the equipment and building materials.**

**The floor or foundation must be level and the condensate drain at the proper height for proper drainage and condensate flow. Standing water and wet surfaces inside the equipment can become an amplification site for microbial growth (mold). If there is evidence of microbial growth on the interior insulation, it should be removed and replaced prior to operating the system.**

- If the unit is to be ceiling mounted, the installer/contractor must provide threaded suspension rods. All units must be installed level.
- Vertical recessed/concealed units require wall/ceiling openings. Refer to submittal for specific dimensions before attempting to install.
- Horizontal recessed/concealed units must meet the requirements of the National Fire Protection

Association (NFPA) Standard 90A or 90B concerning the use of concealed ceiling spaces as return air plenums. Refer to the submittal for specific dimensions of ceiling openings.

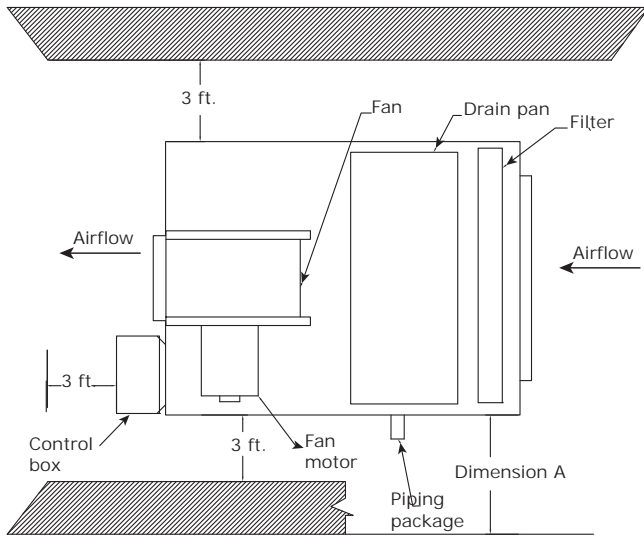
- Touch up painted panels if necessary. If panels need paint, sanding is not necessary. However, clean the surface of any oil, grease, or dirt residue so the paint will adhere. Purchase factory approved touch up epoxy paint from your local Trane Service Parts Center and apply.
- BCHD and BCVD units have either right or left hand piping. Reference piping locations by facing the front of the unit (airflow discharges from the front). The control panel is always on the end opposite the piping. BCCD units have piping on the front of the unit.
- The fan board assembly and main drain pan are easily removable for cleaning.



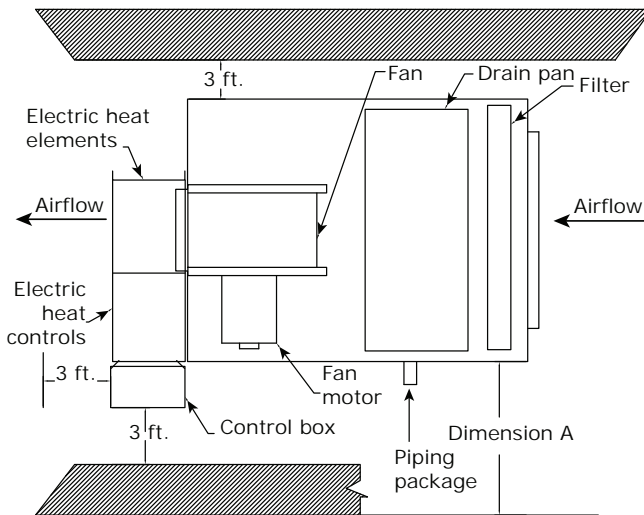
# Dimensions and Weights

## Service Clearances

**Figure 3. Recommended service clearance**



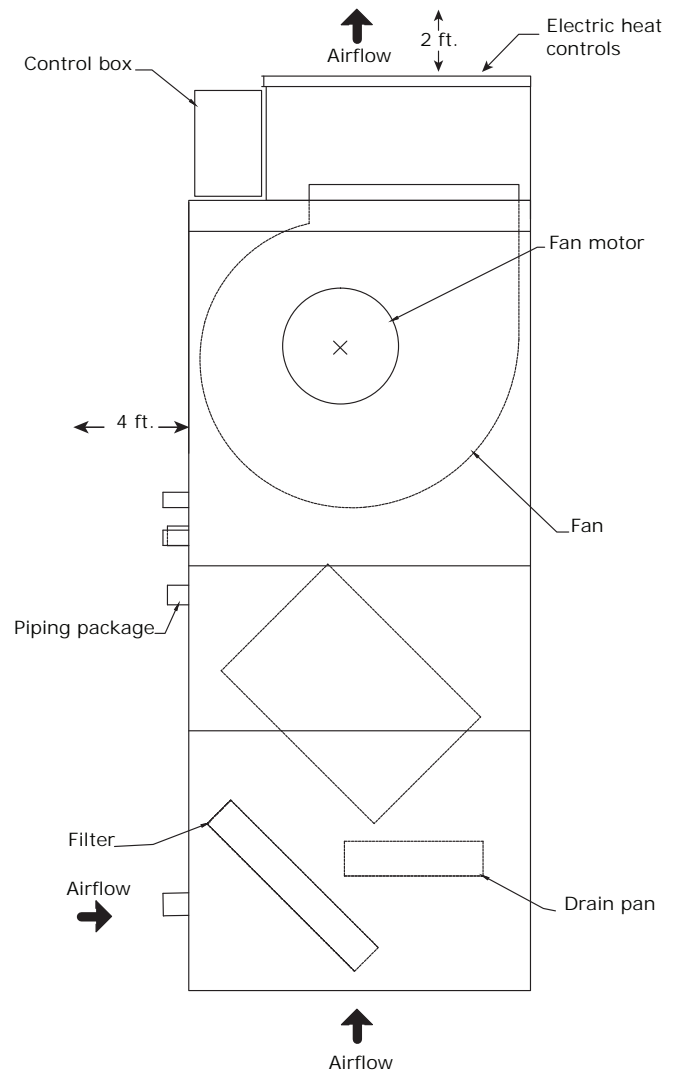
**Figure 4. Recommended service clearances for blower coil with electric heat**



**Table 1. Service requirements (inches)**

Unit size	Dimension A
12	20
18	25
24	25
36	37
54	37
72	45
90	45

**Figure 5. Service clearance for compact vertical coil**

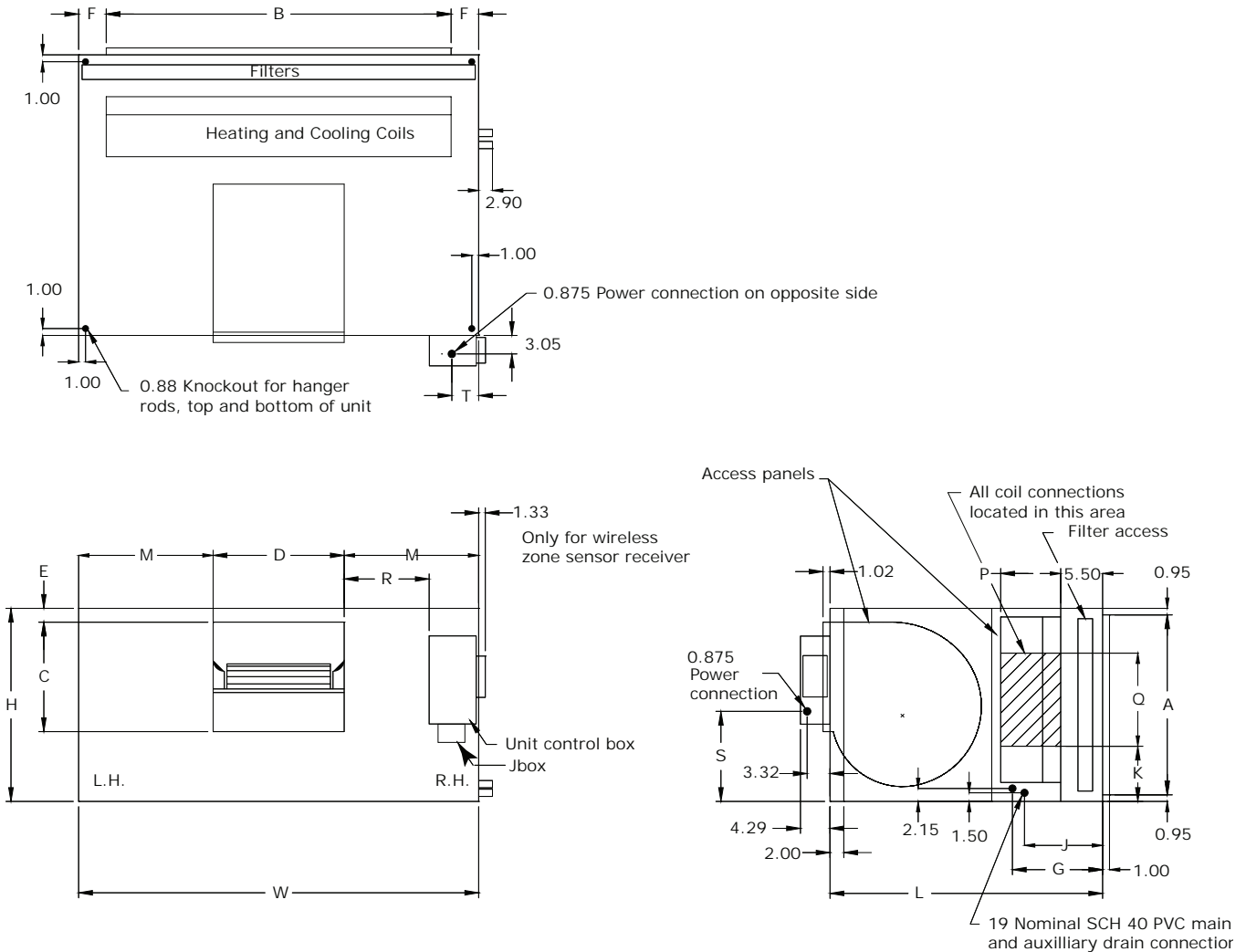




## Dimensions and Weights

# Horizontal Blower Coil

**Figure 6. Horizontal blower coil**



**Table 2. Horizontal blower coil dimensions (in.) and weights (lb)**

Unit Size	H	W	L	A	B	C	D	E	F	G (RH)	G (LH)	J (RH)	J (LH)	K	M	P	Q	R	S	T	Basic Unit Weight
12	14.00	24.00	31.15	12.09	18.00	10.56	7.47	0.55	3.00	11.42	13.42	9.42	11.42	4.20	8.24	9.00	5.75	1.35	0.99	4.26	64.00
18	14.00	28.00	31.15	12.09	22.00	10.56	7.47	0.55	3.00	11.42	13.42	9.42	11.42	4.20	10.24	9.00	5.75	3.42	0.99	4.19	69.00
24	18.00	28.00	33.72	16.09	22.00	13.57	9.04	1.30	3.00	11.42	13.42	9.42	11.42	6.20	9.68	9.00	5.75	2.73	1.17	4.09	89.60
36	18.00	40.00	33.72	16.09	34.00	13.57	9.04	1.30	3.00	11.42	13.42	9.42	11.42	6.20	15.68	9.00	5.75	8.64	1.01	4.19	104.50
54	22.00	40.00	41.57	20.09	34.00	13.58	12.57	0.72	3.00	11.42	13.42	9.42	11.42	7.43	13.72	11.00	7.27	6.87	5.01	4.19	129.00
72	22.00	48.00	41.57	20.09	40.00	13.58	12.57	0.72	4.00	11.42	13.42	9.42	11.42	7.43	17.72	11.00	7.27	10.87	5.01	4.19	142.00
90	28.00	48.00	43.94	26.09	40.00	13.58	12.57	1.66	4.00	12.79	14.79	10.79	12.79	8.24	17.72	11.25	11.64	10.92	11.14	4.14	162.80

**Notes:**

1. All coil connections are sweat style.
2. Weight of basic unit includes cabinet, fan, wiring and average filter. It does not include coil, motor or shipping package. Add to basic unit weight seven pounds for weight of control box.
3. Control box factory-mounted on drive side.

## Vertical Blower Coil

Figure 7. Vertical blower coil

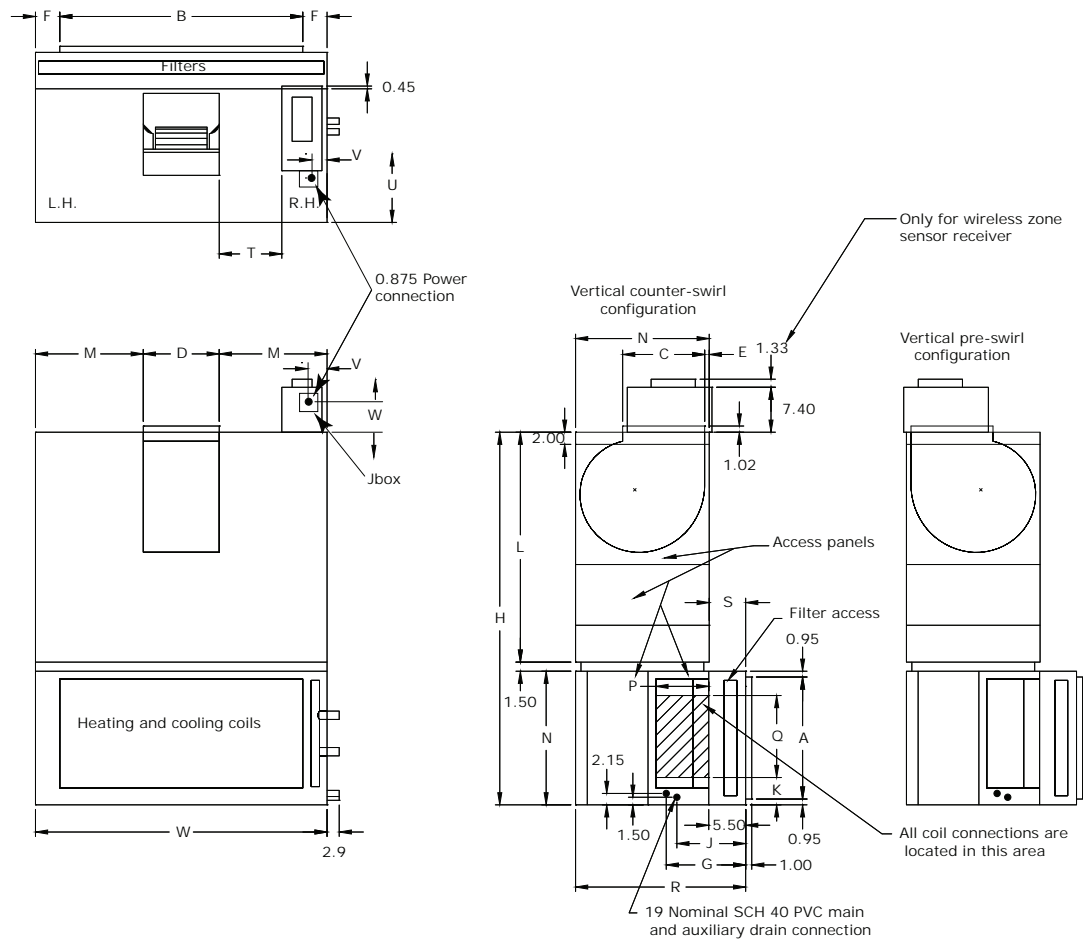


Table 3. Vertical blower coil dimensions (in.) and weights (lb)

Unit Size	H	W	L	A	B	C	D	E	F	G (RH)	G (LH)	J (RH)	J (LH)
24	51.72	28.00	32.22	16.09	22.00	13.57	9.04	1.30	3.00	11.42	13.42	9.42	11.42
36	51.72	40.00	32.22	16.09	34.00	13.57	9.04	1.30	3.00	11.42	13.42	9.42	11.42
54	63.57	40.00	40.07	20.09	34.00	13.58	12.57	0.72	3.00	11.42	13.42	9.42	11.42
72	63.57	48.00	40.07	20.09	40.00	13.58	12.57	0.72	4.00	11.42	13.42	9.42	11.42
90	71.94	48.00	42.44	26.09	40.00	13.58	12.57	1.66	4.00	12.79	14.79	10.79	12.79

Unit Size	K	M	N	P	Q	R	S	T	U	V	W	Basic Unit Weight
24	6.20	9.68	18.00	9.00	5.50	28.00	10.00	1.96	4.88	3.90	4.56	141.10
36	6.20	15.68	18.00	9.00	5.50	28.00	10.00	8.63	4.88	3.23	4.56	168.80
54	4.21	13.72	22.00	11.00	7.27	30.00	8.00	6.87	8.88	3.23	4.56	197.40
72	4.18	17.72	22.00	11.00	7.27	30.00	8.00	5.83	8.88	8.27	4.56	218.00
90	4.81	17.72	28.00	11.25	11.64	30.00	2.00	7.84	14.88	6.26	4.56	246.40

**Notes:**

1. All coil connections are sweat style.
2. Weight of basic unit includes cabinet, fan, wiring and average filter. Add to basic unit weight seven pounds for weight of control box. Control box factory-mounted on motor side.
3. Vertical coil and filter section ships separate for field installation. Refer to installation and maintenance manual for instructions.
4. Vertical units provided with 6-inch high mounting legs. Legs are seismic rated.

# Compact Vertical Blower Coil

Figure 8. BCCD Compact Vertical Blower Coil

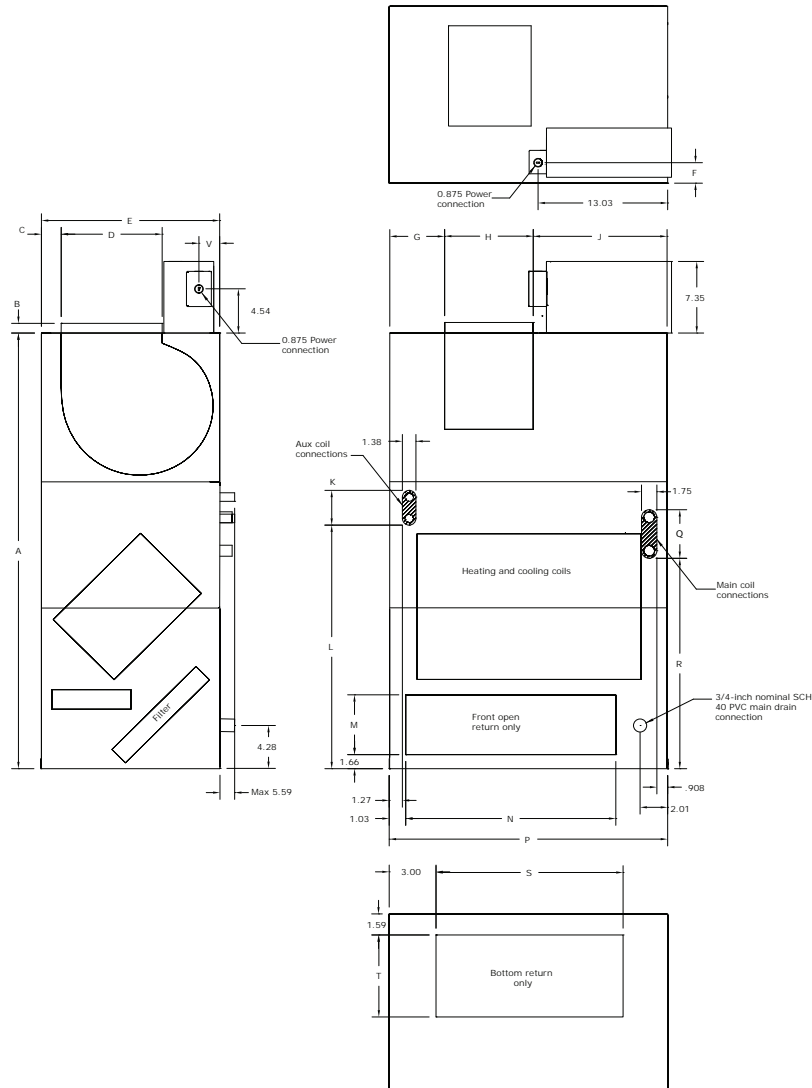


Table 4. BCCD Compact vertical blower coil dimensions (in.) and weights (lb)

Unit Size	A	B	C	D	E	F	G	H	J	K
24	44.50	1.00	2.00	10.25	18.00	2.10	5.51	9.01	13.48	8.00
36	48.50	1.00	2.00	10.25	21.50	3.74	5.51	9.01	13.48	8.00
48	55.50	1.00	1.25	13.25	23.00	3.74	7.03	11.51	14.46	7.88
60	57.50	1.00	1.25	13.25	26.00	3.98	7.03	11.51	14.46	7.88
Unit Size	L	M	N	P	Q	R	S	T	Basic Unit Weight	
24	20.56	6.19	22.43	28.00	7.05	21.50	22.00	7.00	111	
36	24.70	9.63	22.43	28.00	7.05	25.64	22.00	11.20	125	
48	26.19	11.48	27.43	33.00	9.53	25.96	27.00	12.48	163	
60	29.04	14.60	27.43	33.00	7.65	30.67	27.00	16.22	174	

**Notes:**

1. All coil connections are sweat style.
2. Weight of basic unit includes cabinet, fan, wiring and average filter. Does not include coil, motor, or shipping package. Add to basic unit weight seven pounds for weight of control box.

## Angle Filter and Mixing Box

Figure 9. Angle filter and mixing box dimensions

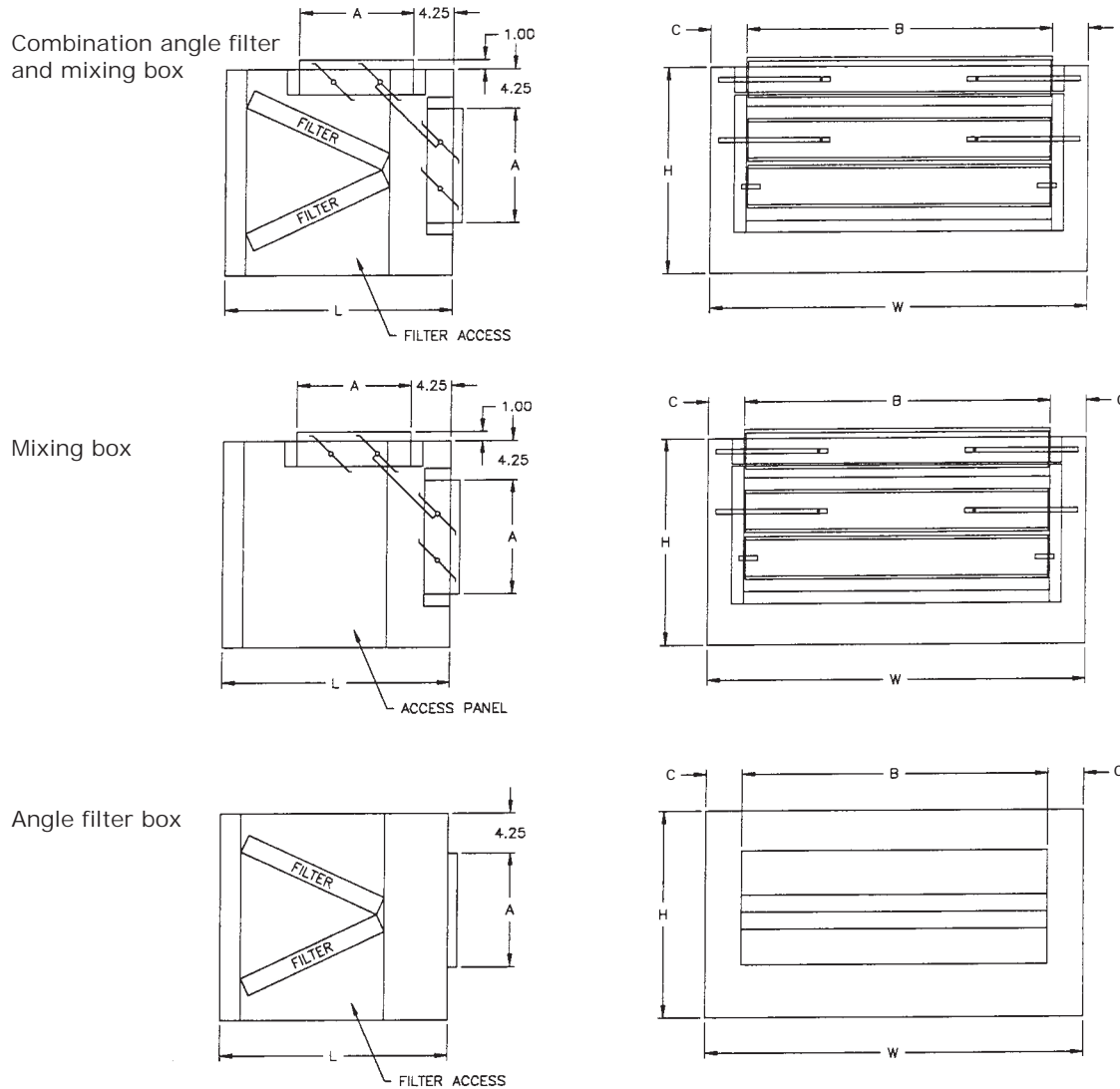


Table 5. Angle filter and mixing box dimensions (in.) and weights (lb)

Unit Size	H	L	W	A	B	C	Weight
12	14.12	22.00	24.11	7.06	15.56	4.28	36.0
16	14.12	22.00	28.11	7.06	19.56	4.28	41.0
24	18.12	19.50	28.11	7.06	19.56	4.28	43.0
36	18.12	24.50	40.11	7.06	31.56	4.28	56.0
54	22.12	23.50	40.11	12.81	31.56	4.28	72.0
72	22.00	23.50	48.00	12.81	31.56	8.22	72.5
90	27.90	27.56	48.00	12.85	31.56	8.22	84.1

## Dimensions and Weights

### Bottom or Top Access Filter Box

Figure 10. Bottom or top access filter box

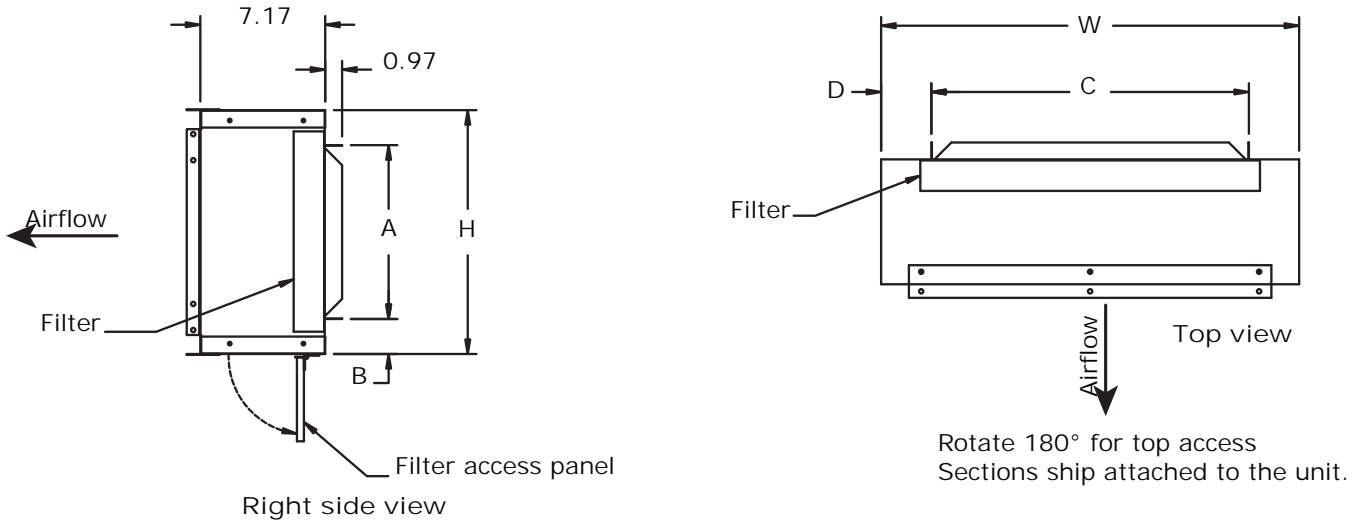


Table 6. Bottom or top access filter box dimensions (in.) and weights (lb)

Unit Size	H	W	A	B	C	D	Weight
12	14.00	24.00	9.98	2.01	18.23	2.88	15
18	14.00	28.00	9.98	2.01	21.98	3.01	17
24	18.00	28.00	14.23	1.89	23.23	2.38	18
36	18.00	40.00	14.23	1.89	33.73	3.13	25
54	22.00	40.00	18.23	1.89	33.73	3.13	28
72	22.00	48.00	18.23	1.89	42.73	2.63	32
90	28.00	48.00	23.23	1.89	41.23	3.38	37

## Electric Heat

Figure 11. BCHD/BCVD Blower coils with electric heat

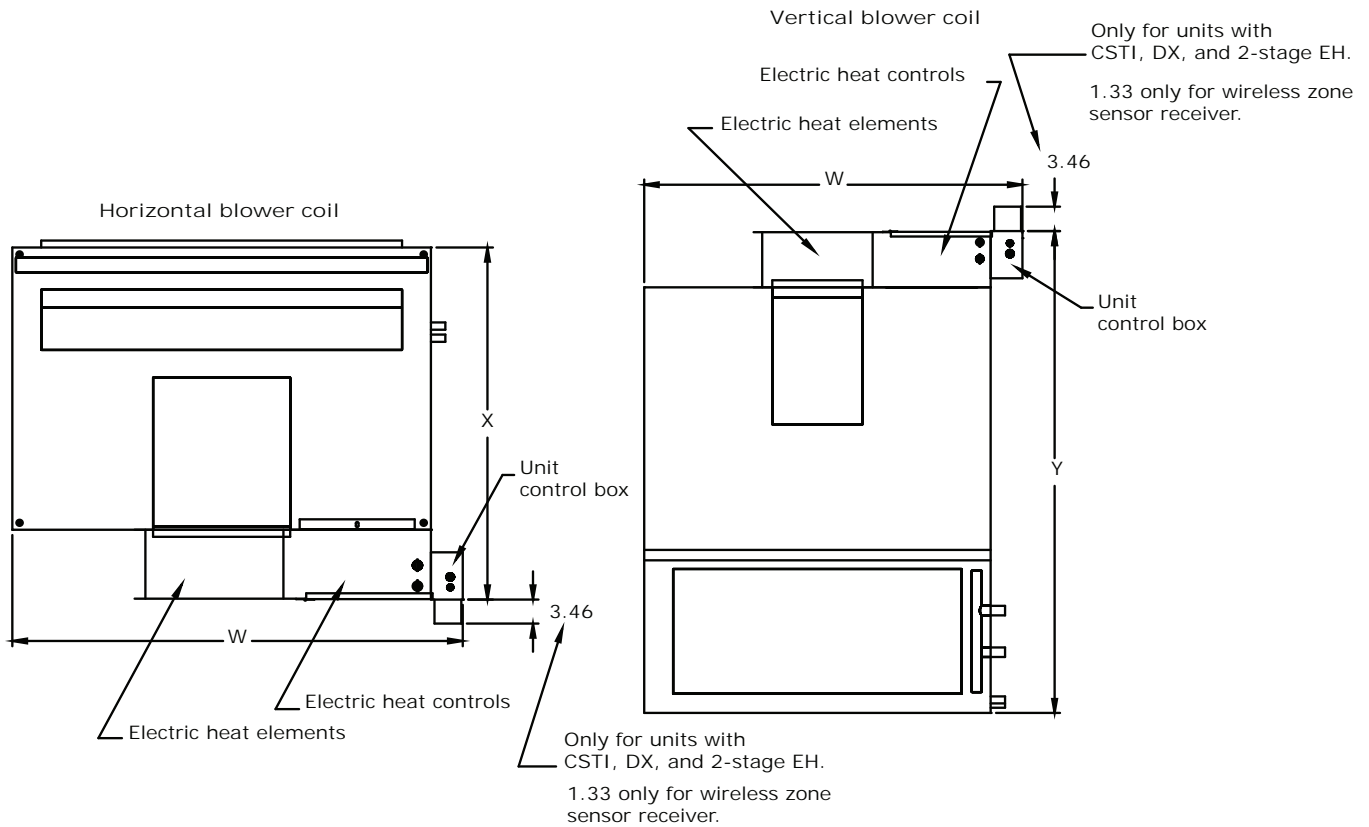


Table 7. BCHD/BCVD Blower coils with electric heat dimensions (in.) and weights (lb)

Unit Size	W	X	Y
12	28.28	37.97	n/a
18	32.29	37.97	n/a
24	30.54	40.75	48.54
36	42.57	40.75	60.57
54	44.32	48.39	66.32
72	48.29	48.60	70.29
90	48.29	50.96	76.29

## Dimensions and Weights

Figure 12. Electric heat section for BCHD/BCVD dimensions

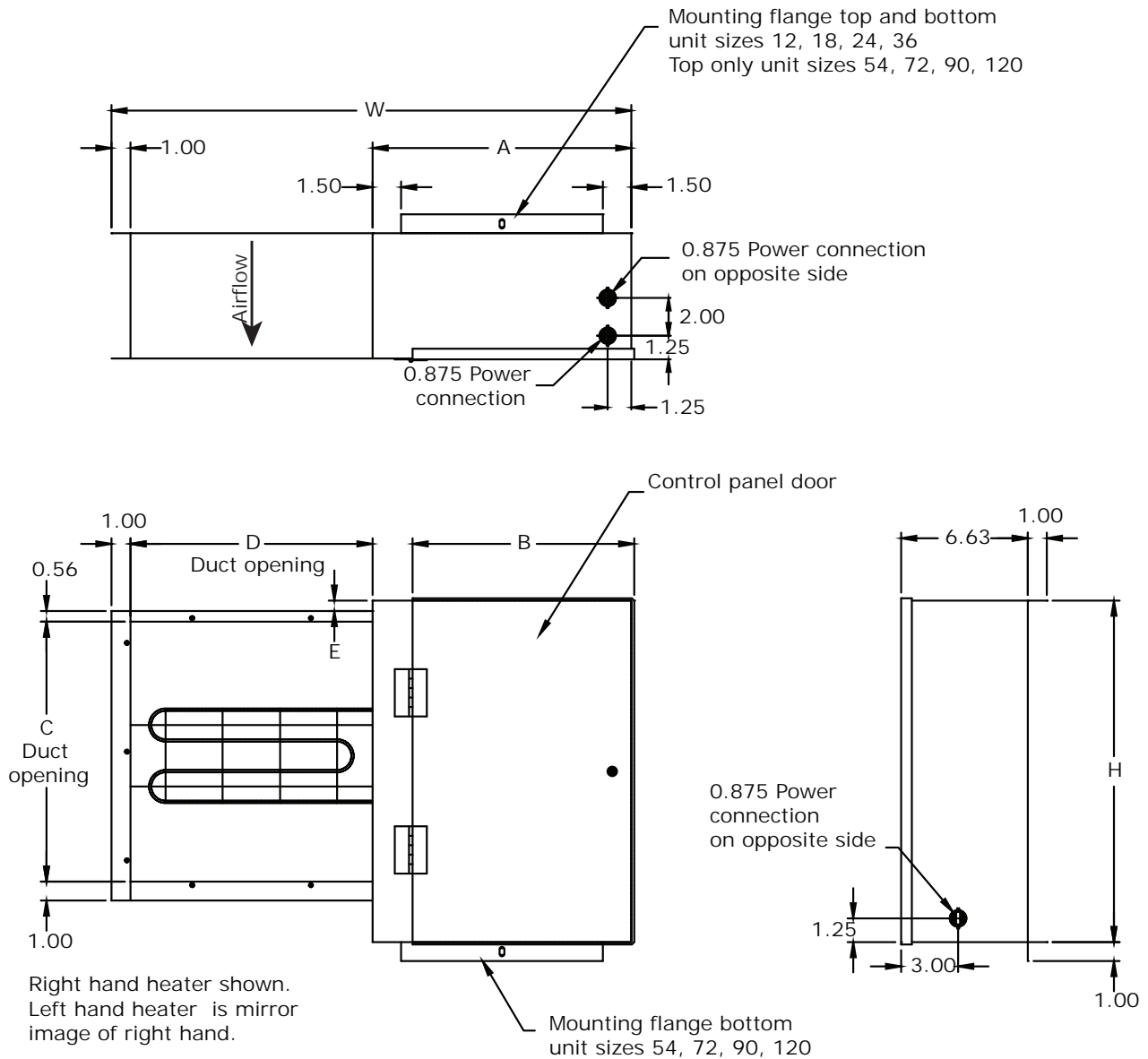
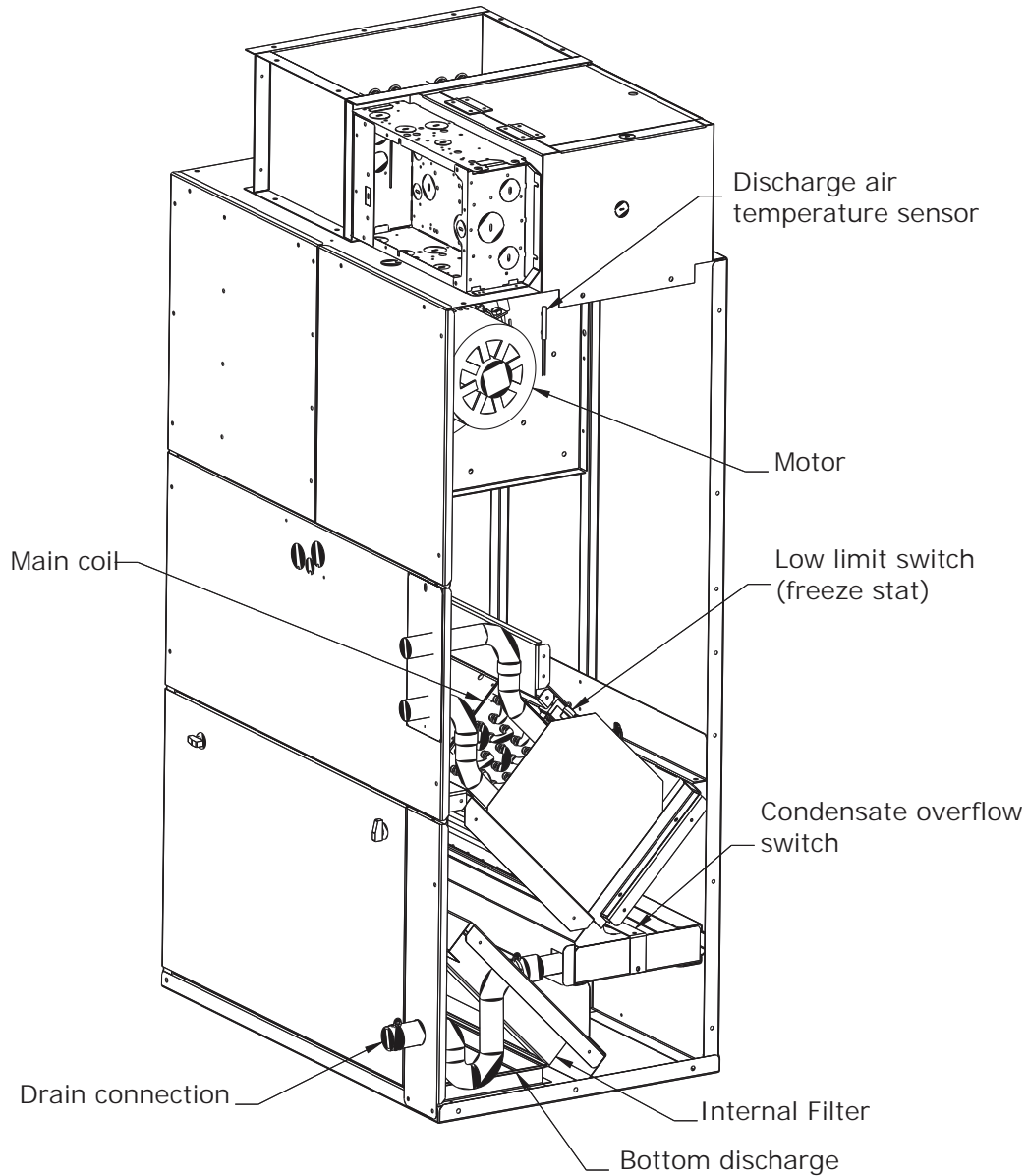


Table 8. Electric heat section for BCHD/BCVD dimensions (in.) and weights (lb)

Unit Size	H	W	A	B	C	D	E	Weight
12	14.06	17.88	8.13	6.79	10.50	8.75	0.03	10.00
18	14.06	19.88	10.13	8.79	10.50	8.75	0.03	10.80
24	18.06	17.75	7.63	6.29	13.50	9.13	0.80	11.30
36	18.06	23.75	13.63	12.29	13.50	9.13	0.80	12.80
54	18.06	27.25	13.63	11.67	13.50	12.63	0.22	16.00
72	18.06	27.25	13.63	11.67	13.50	12.63	0.22	17.40
90	18.06	27.25	13.63	11.67	13.50	12.63	1.16	19.20

- Electric heater is factory mounted on unit discharge face and wired to unit control box.
- Heater may be mounted with horizontal or vertical up airflow.
- Optional mercury contactors cannot be used with vertical up airflow.
- Electric heat may need field-supplied externally-wrapped insulation if the unit is installed in an unconditioned space or if sweating is an issue.

**Figure 13. BCCD Blower coil with electric heat section**



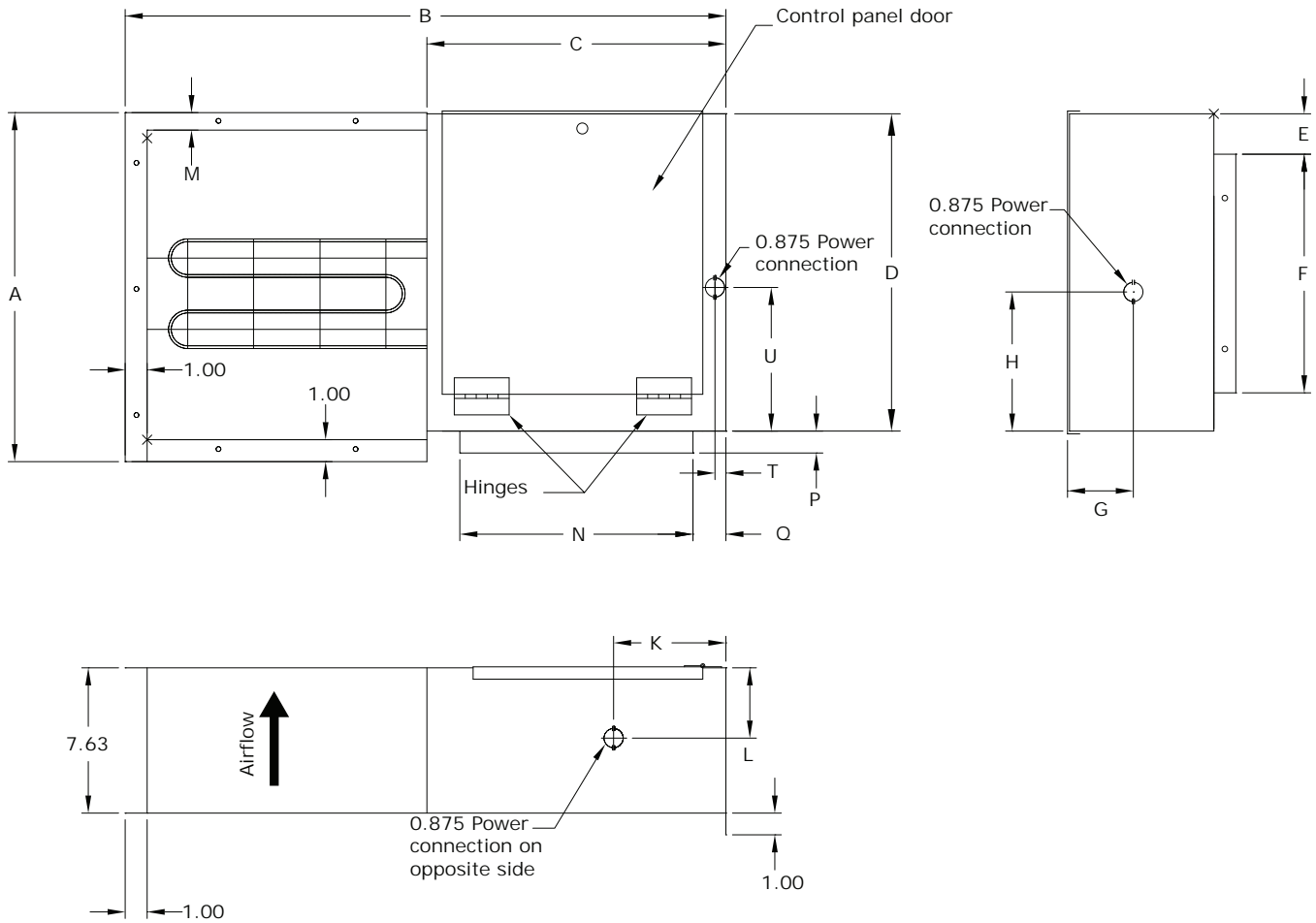
Outside air sensor located in outside air ductwork  
 Discharge air temp sensor field-installed in ductwork

**Table 9. BCCD Blower coils with electric heat section dimensions (in.)**

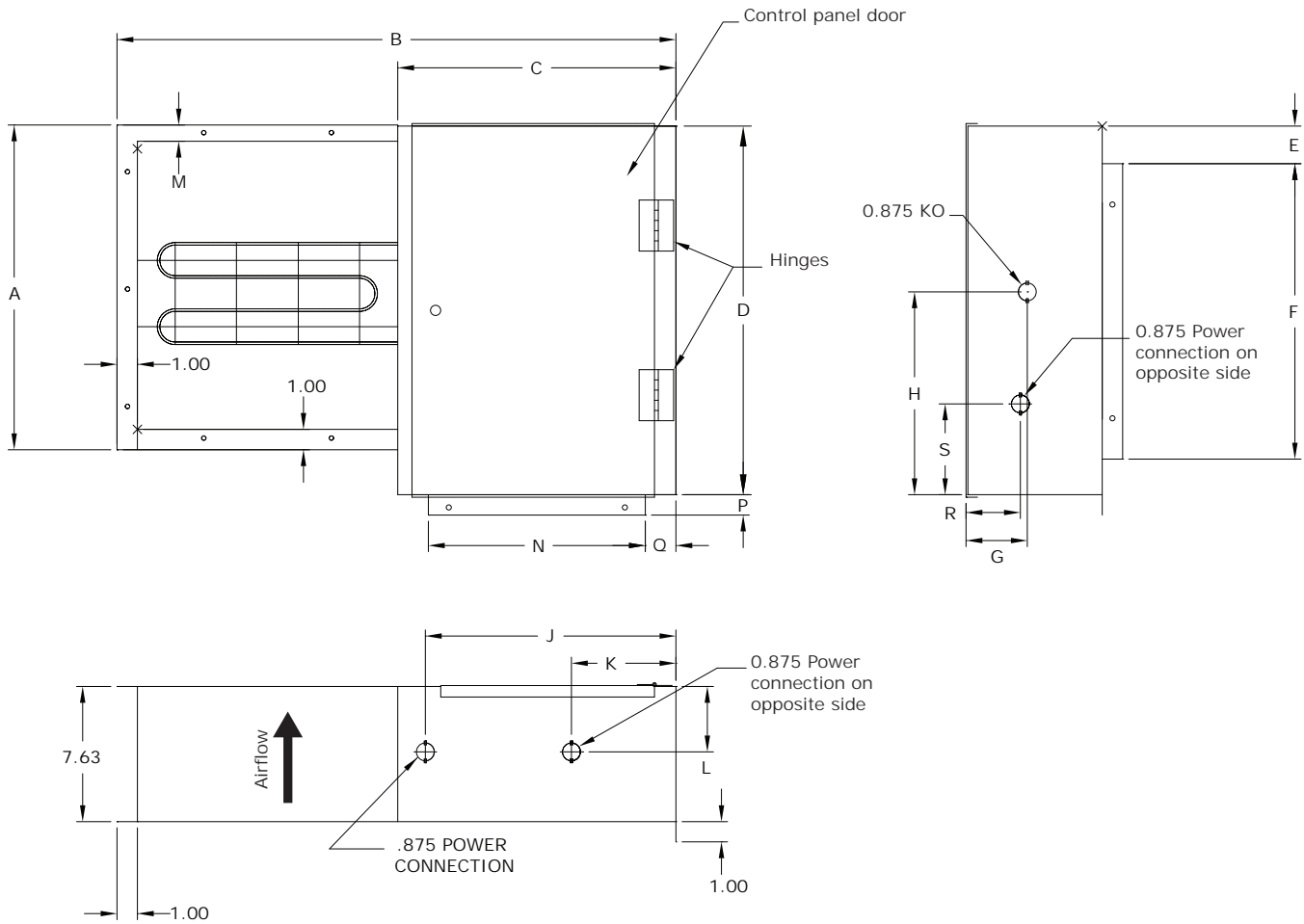
Unit size	A	B
26	52.00	28.00
36	56.00	28.00
48	63.00	33.00
60	65.00	33.00

# Dimensions and Weights

**Figure 14. Electric heat section for BCCD size 24-36**



**Figure 15. Electric heat section for BCCD size 48-60**



**Table 10. Electric heat section for BCCD dimensions (in.) and weights (lb)**

Unit Size	A	B	C	D	E	F	G	H	J	K	L	M	N	P	Q	R	S	T	U	Weight
24	15.06	10.13	13.48	10.99	1.12	8.67	3.88	5.12	n/a	6.74	3.66	0.56	7.09	0.63	3.95	n/a	n/a	0.56	5.77	15.20
36	15.06	10.13	13.46	13.54	2.03	9.46	4.25	6.41	n/a	7.77	3.72	0.56	8.13	1.00	2.64	n/a	n/a	0.56	7.08	17.20
48	15.25	12.17	14.68	15.59	1.83	11.92	3.90	7.80	13.66	7.34	3.75	0.75	8.64	1.00	3.04	n/a	n/a	n/a	n/a	21.50
60	15.26	12.17	16.68	18.49	0.79	16.91	3.88	9.34	12.93	7.34	3.88	0.76	9.94	1.00	2.39	3.88	3.79	n/a	n/a	23.40

- Electric heater is factory mounted on unit discharge face and wired to unit control box.
- Electric heat may need field-supplied externally-wrapped insulation if the unit is installed in an unconditioned space or if sweating is an issue.

## Dimensions and Weights

### Steam Coil

Figure 16. Steam coil dimensions

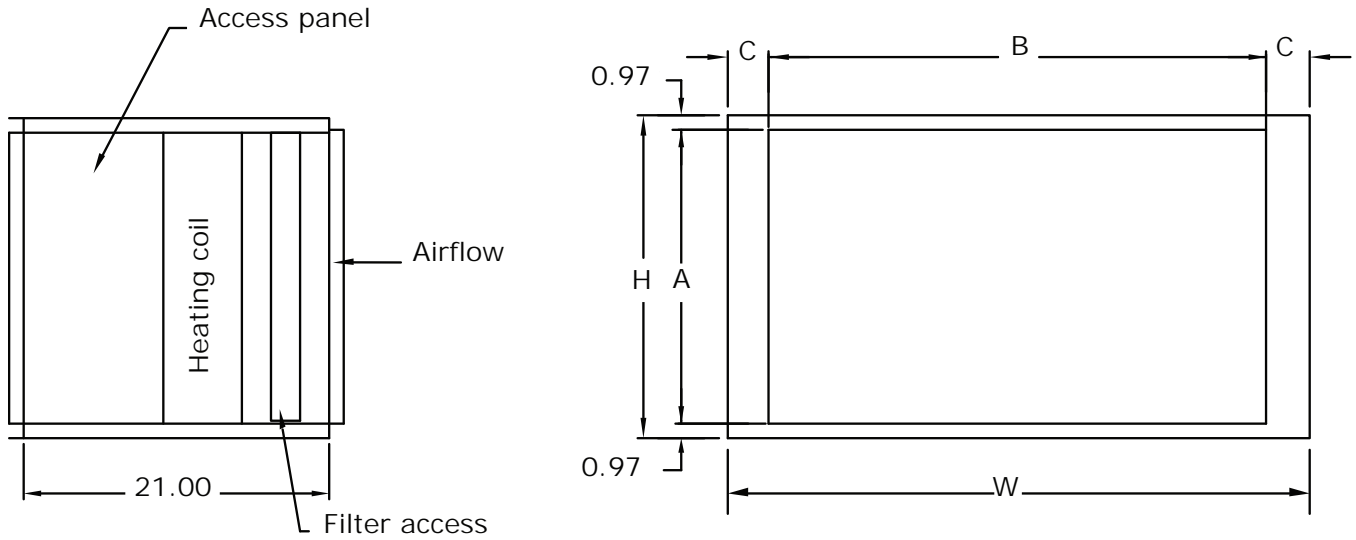


Table 11. Steam coil box dimensions (in.) and weights (lb)

Unit Size	H	W	A	B	C	Weight	Coil Connections, NPT	
							Supply	Return
12	14.00	24.00	12.06	18.04	2.98	34	1	3/4
18	14.00	28.00	12.06	22.04	2.98	37	1	3/4
24	18.00	28.00	16.06	22.04	2.98	40	1-1/2	1
36	18.00	40.00	16.06	34.04	2.98	48	1-1/2	1
54	22.00	40.00	20.06	34.04	2.98	50	2	1
72	22.00	48.00	20.06	42.04	2.98	56	2	1
90	28.00	48.00	26.06	40.04	3.98	63	2-1/2	1 1/4

**Notes:**

1. Filter access and access panel located on both sides.
2. Weight includes cabinet with average filter, but does not include coil weight. See general data section for coil weights.

## Coil Connections

**Table 12. Hydronic coil connection sizes, OD (in.)**

Unit Size	Standard Capacity			High Capacity		
	1-Row	4-Row	6-Row	2-Row	4-Row	6-Row
12	5/8	—	—	5/8	7/8	7/8
18	5/8	—	—	5/8	7/8	7/8
24	5/8	—	—	7/8	1-1/8	1-1/8
36	5/8	—	—	7/8	1-1/8	1-1/8
54	1-1/8	1-3/8	1-3/8	1-1/8	1-1/8	1-1/8
72	1-1/8	1-3/8	1-3/8	1-1/8	1-1/8	1-1/8
90	1-1/8	1-5/8	1-5/8	1-1/8	1-1/8	1-1/8

**Table 13. DX coil connection sizes, OD (in.)**

Unit Size	3-Row and 4-Row		6-Row	
	Suction	Liquid	Suction	Liquid
12	5/8	5/8	5/8	5/8
18	5/8	5/8	5/8	5/8
24	5/8	5/8	7/8	5/8
36	7/8	5/8	7/8	5/8
54	1-1/8	7/8	1-1/8	7/8
72	1-1/8	7/8	1-1/8	7/8
90	1-3/8	7/8	1-1/8	7/8

**Table 14. Steam coil connection sizes, female connection, NPT (in.)**

Unit Size	Supply	Return
12	1	3/4
18	1	3/4
24	1-1/2	1
36	1-1/2	1
54	2	1
72	2	1
90	2-1/2	1-1/4

## Piping Packages

**Table 15. Piping package dimensions (in.)**

Piping Package	Nominal Tube Size	Actual Size	Valve Size	A	B	C	D	E	F
2-way, Basic	0.750	0.875	0.750	11.31	2.62	-	-	-	-
	1.000	1.125	1.000	16.06	4.40	-	-	-	-
	1.250	1.375	1.000	16.04	3.70	-	-	-	-
2-way, Deluxe	0.750	0.875	0.750	11.31	-	6.87	-	-	-
	1.000	1.125	1.000	16.06	-	9.76	-	-	-
	1.250	1.375	1.000	16.04	-	9.95	-	-	-
3-way, Basic	0.750	0.875	0.500	14.17	0.96	-	1.86	6.07	-
	0.750	0.875	0.750	11.11	3.16	-	2.39	7.98	-
	1.000	1.125	1.000	16.05	1.35	-	-	6.68	5.51
3-way, Deluxe	1.250	1.375	1.000	18.54	1.22	-	-	7.57	7.02
	0.750	0.875	0.500	15.81	3.56	-	1.86	6.07	-
	0.750	0.875	0.750	12.75	5.76	-	2.39	7.99	-
3-way, Deluxe	1.000	1.125	1.000	14.91	5.17	-	-	6.68	5.51
	1.250	1.375	1.000	18.09	5.47	-	-	7.57	7.02

Basic Piping

Figure 17. 2-way basic piping package

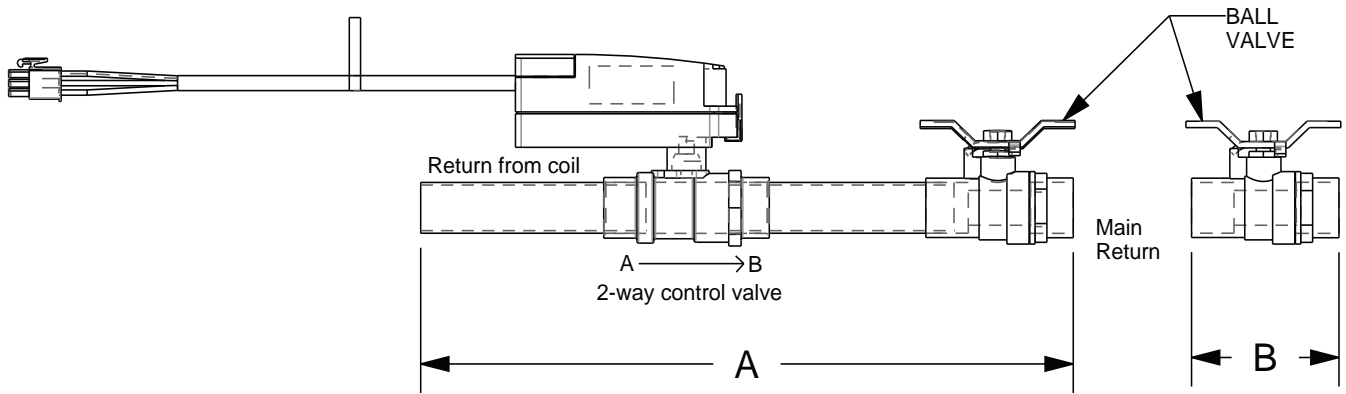


Figure 18. 3-way basic piping package – 3/4-in. piping

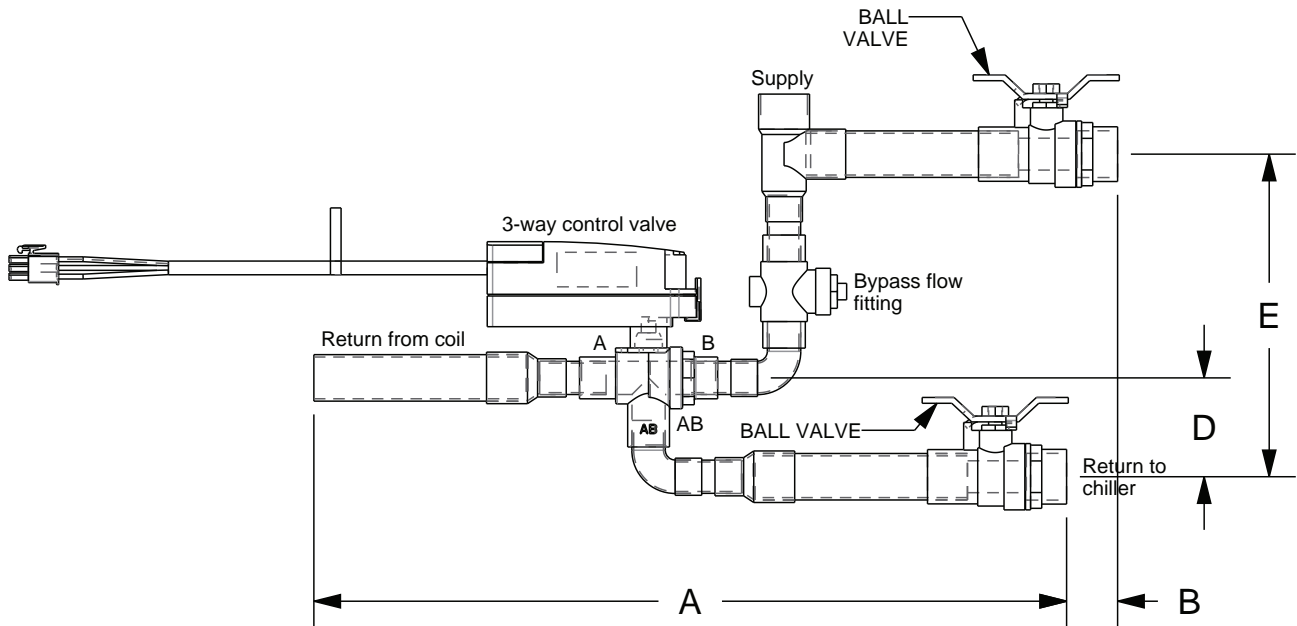
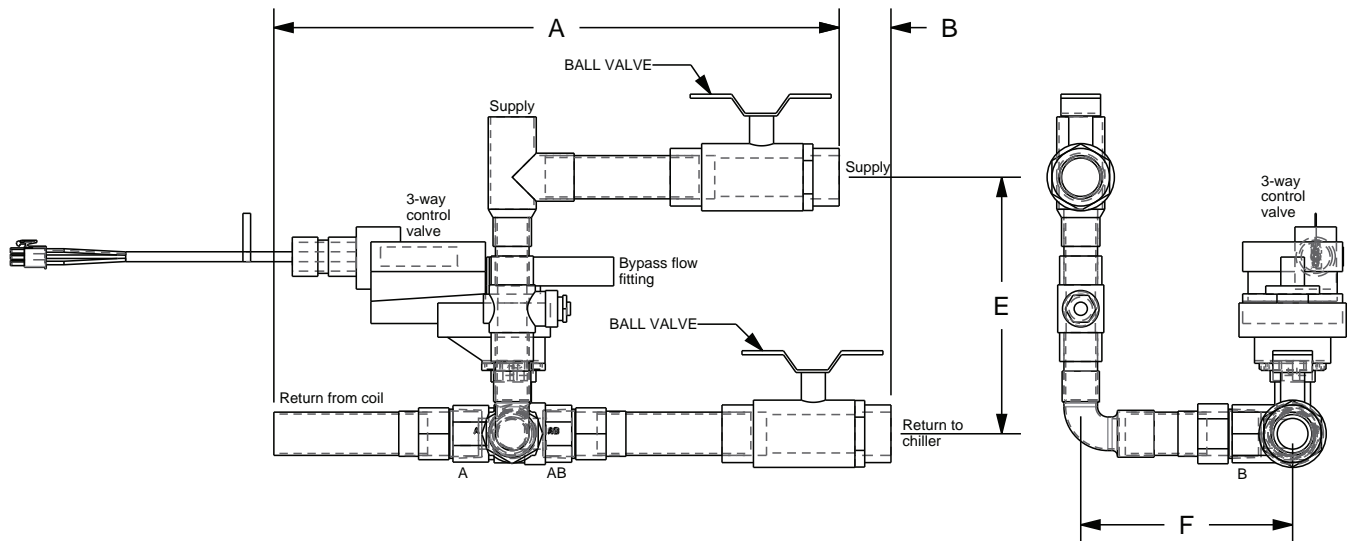
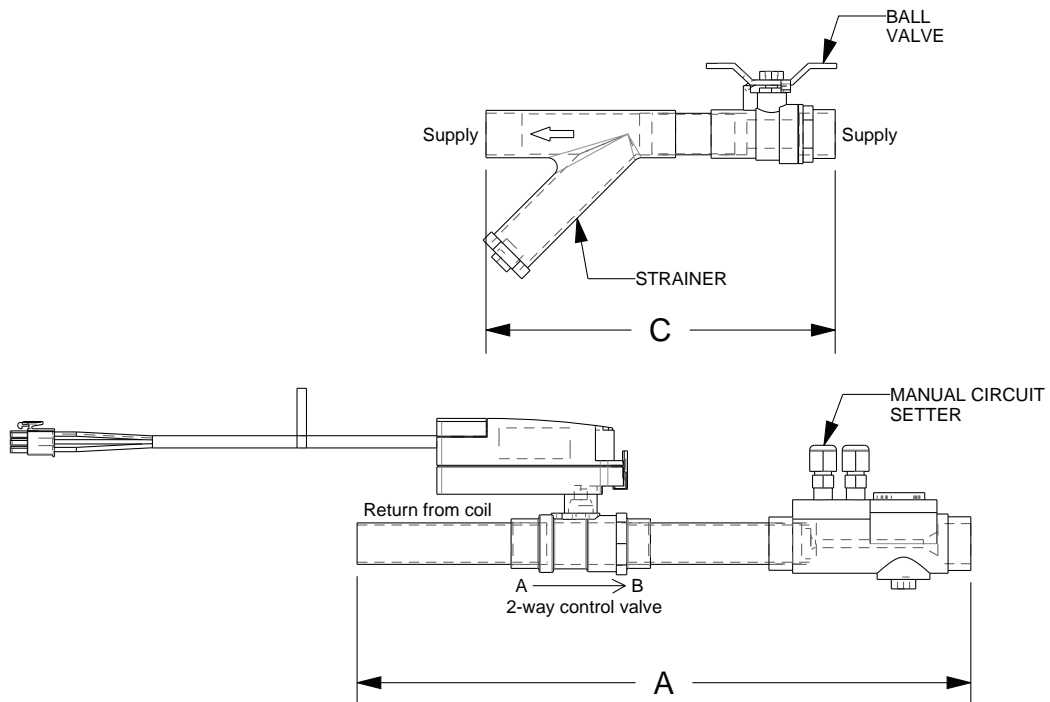


Figure 19. 3-way basic piping package – 1-in. and 1 1/4-in. piping



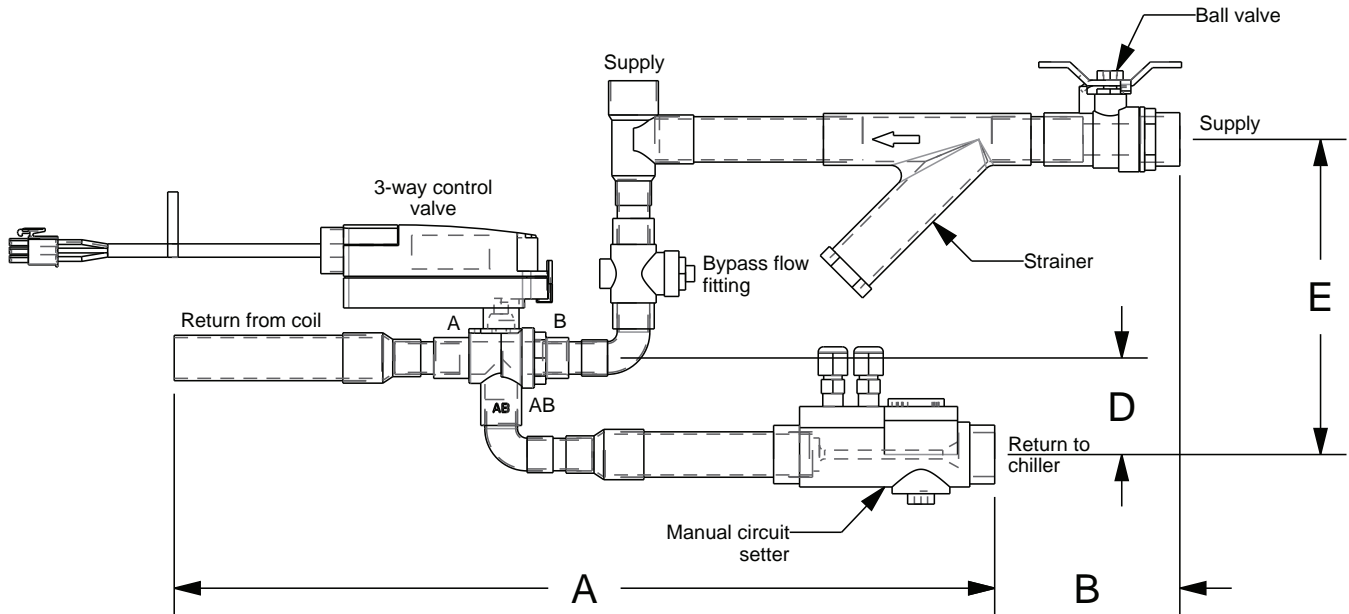
### Deluxe Piping

Figure 20. 2-way deluxe piping package

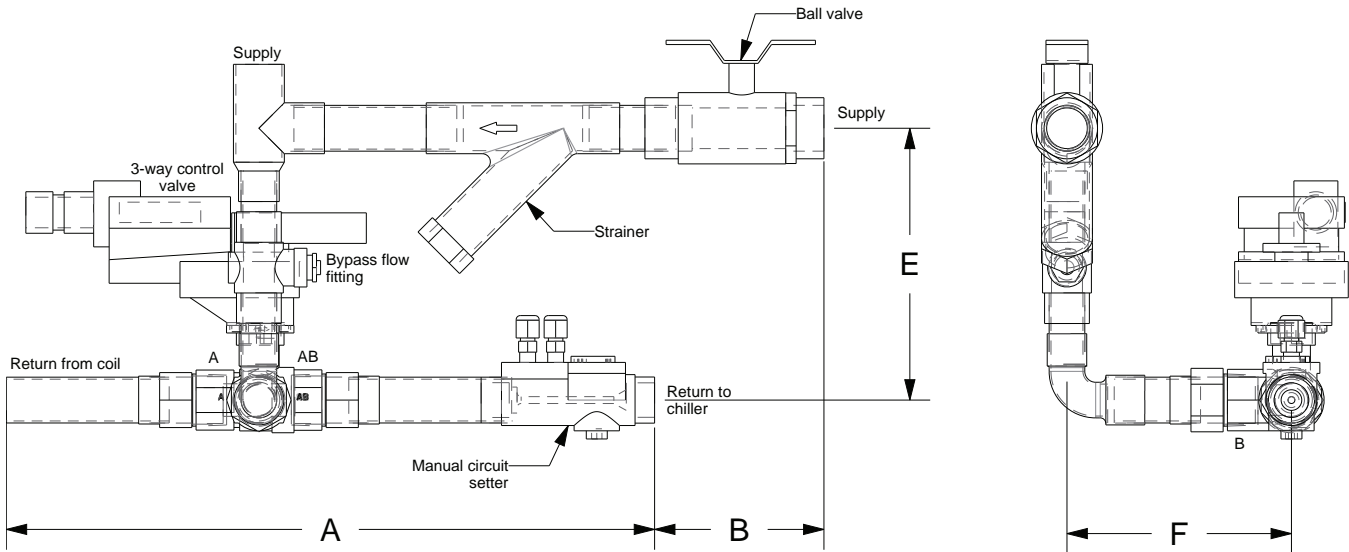


## Dimensions and Weights

**Figure 21. 3-way deluxe piping package – 3/4-in. piping**



**Figure 22. 3-way deluxe piping package – 1-in. and 1 1/4-in. piping**



### Valve and Actuator Operation (All valves except for 7.4 Cv and 10.0 Cv)

- Two position actuators are different for normally open (N.O.) and normally close (N.C.), and are capacitor discharge return.
- Valve operation is the same.
- All actuators are clockwise to close, counterclockwise to open with wire harness facing towards you and looking at the top of the actuator.

## Valve Stroke Time

**Table 16. Valve stroke time**

Valve Selection	Clip Position	Stroke Time (seconds)
2.3 Cv, 3/4 in. 2-way valve	4	49
3.3 Cv, 3/4 in. 2-way valve	5	55
4.6 Cv, 3/4 in. 2-way valve	6	62
1.0 Cv, 1/2 in. 3-way valve	No end stop	75
2.7 Cv, 1/2 in. 3-way valve	No end stop	75
4.6 Cv, 3/4 in. 3-way valve	No end stop	75
7.4 Cv, 1 in. 2-way and 3-way valve isolation	N/A	75
10.0 Cv, 1-1/4 in. 2-way and 3-way valve isolation	N/A	75
7.4 Cv, 1 in. 2-way and 3-way valve modulating	N/A	90
10.0 Cv, 1-1/4 in. 2-way and 3-way valve modulating	N/A	90

## Field-Set Flow Capacity Adjustment (All valves except for 7.4 Cv and 10.0 Cv)

- If a different Cv is required, align the clip to the notch scale found on the underside of the actuator to the corresponding Cv in the table below.
- For 3-point floating, control signals adjust the controller stroke time parameter to match the stroke time of the of the final clip position.
- For all 3-way valves, the stroke time is 75 seconds and there is no end stop on the actuator.
- The Cv can not be changed for 3-way valves.

**Figure 23. Cv adjustments**

**Table 17. Actuator clip settings**

2-way Valve Body	1	2	3-	3	4	4+	5	5+	6	N	No End Stop
1/2 in. Z2050QS-F Cv	0.1		0.2			0.4		0.6	0.8	1.2	1.4
1/2 in. Z2050QS-J Cv	0.5	0.7		1.2	1.7		2.4		3.4	4.8	5.9
3/4 in. Z2075QS-K Cv	0.5	1		1.5	2.3 <sup>(a)</sup>		3.3 <sup>(a)</sup>		4.6 <sup>(a)</sup>	6.6	9.8
Stroke Time (seconds)	30	37	41	43	49	51	55	58	62	68	75

(a) This Cv shows the standard Cv offering for 2-way valves.



# Installation - Mechanical

## Lifting and Rigging

### **⚠ WARNING**

#### **Improper Unit Lift!**

Failure to properly lift unit in a **LEVEL** position could result in unit dropping and possibly crushing operator/technician which could result in death or serious injury, and equipment or property-only damage. Test lift unit approximately 24 inches (61 cm) to verify proper center of gravity lift point. To avoid dropping of unit, reposition lifting point if unit is not level.

### **NOTICE**

#### **Equipment Damage!**

Keep skid in place until unit is ready to set as premature skid removal could result in equipment damage. Do not move the unit or subassembly without the skid in place as shipped from the factory.

## General Lifting Considerations

Before preparing the unit for lifting, estimate the approximate center of gravity for lifting safety. Because of placement of internal components, the unit weight may be unevenly distributed, with more weight in the coil and fan areas. Refer to the unit submittals for actual section weights. Test the unit for proper balance before lifting.

Before hoisting the unit into position, use a proper rigging method such as straps, slings, or spreader bars for protection and safety. Always test-lift the unit to determine the exact unit balance and stability before hoisting it to the installation location.

### **⚠ WARNING**

#### **Heavy Objects!**

Failure to follow instructions below or properly lift unit could result in unit dropping and possibly crushing operator/technician which could result in death or serious injury, and equipment or property-only damage. Ensure that all the lifting equipment used is properly rated for the weight of the unit being lifted. Each of the cables (chains or slings), hooks, and shackles used to lift the unit must be capable of supporting the entire weight of the unit. Lifting cables (chains or slings) may not be of the same length. Adjust as necessary for even unit lift.

1. Position rigging sling under wood skid using spreader bars to avoid unit damage.
2. Use a forklift with caution to prevent unit damage. The fork length must be at least 68 inches long to safely fork the unit from front or back.
3. The unit center of gravity will fall within the center of gravity block at various locations depending on unit options.

### **⚠ WARNING**

#### **Hazardous Voltage!**

Failure to disconnect power before servicing could result in death or serious injury. Disconnect all electric power, including remote disconnects before servicing. Follow proper lockout/tagout procedures to ensure the power can not be inadvertently energized. Verify that no power is present with a voltmeter.

## Installation Procedure

Follow the procedures below to install the blower coil unit.

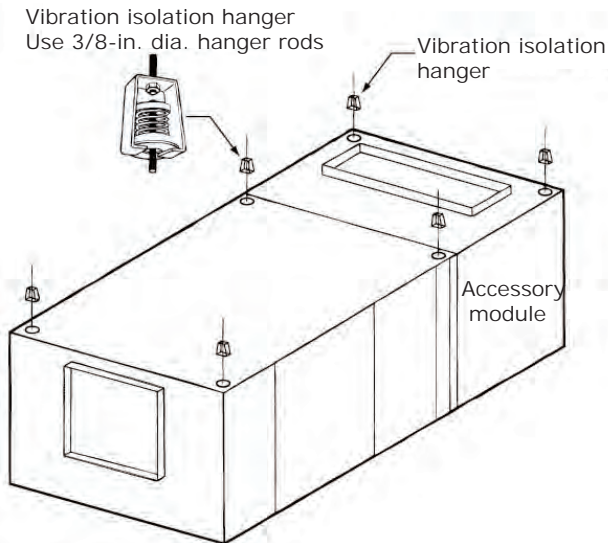
### **Horizontal Unit (Model BCHD) Installation**

Install horizontal units suspended from the ceiling with 3/8-in. threaded rods that are field-provided. There are two knockouts in each corner of the unit for installation of the threaded rods. Ensure the ceiling opening is large enough for unit installation and maintenance requirements.

#### **Materials needed:**

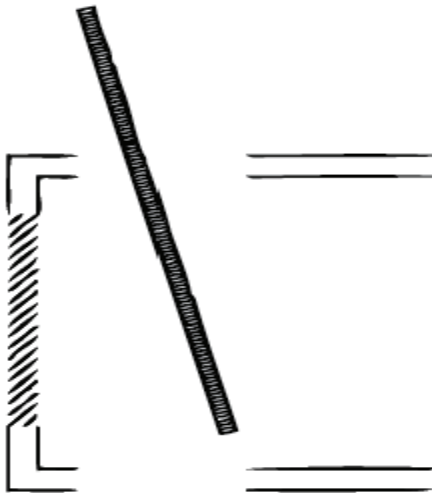
- Washers: 3/8-in., 1/2-in., and 3/4-in. (8 total)
  - Threaded rods, 3/8-in. (4 per unit and 2 per accessory section)
  - Nuts (8)
  - Flat washers or steel plates (8)
  - Vibration isolator hangers or turnbuckles (4 per unit and 2 per angle filter/mixing box/steam coil module)
1. Determine the unit mounting hole dimensions. Prepare the hanger rod isolator assemblies, which are field-provided. Add a stack of 3/8-in., 1/2-in., and 3/4-in. washers to the top and bottom of the unit to hold it securely on the 3/8-in. rod, and install them in the ceiling. Trane recommends using threaded rods to level the unit.

**Figure 24. Ceiling mounted horizontal unit**



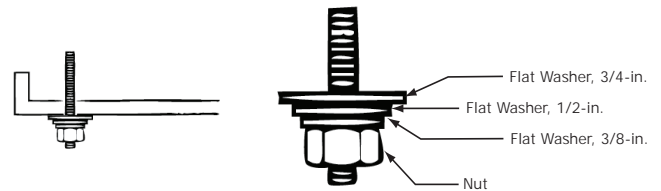
2. Remove motor access panels and filter access panels.
3. Punch out the eight knockouts in the top and bottom panels.
4. Guide the threaded rod through the unit from the top, careful not to damage insulation or wiring. See the following figure. Insert the threaded rod at an angle to help prevent internal unit damage.

**Figure 25. Angle threaded rod through knockouts**



5. Put a nut and flat washers or steel plate on the bottom of the threaded rod (see the following figure).

**Figure 26. Add nut and flat washers to threaded rod**



6. Put a nut and flat washer or steel plate on the top to prevent air leakage.
7. Thread the top of the rod into the isolator or turnbuckle.
8. Hoist the unit to the suspension rods and attach with washers and lock-nuts (see the above figure for details).
9. Level the unit for proper coil drainage and condensate removal from the drain pan.
10. Connect the ductwork to the unit.

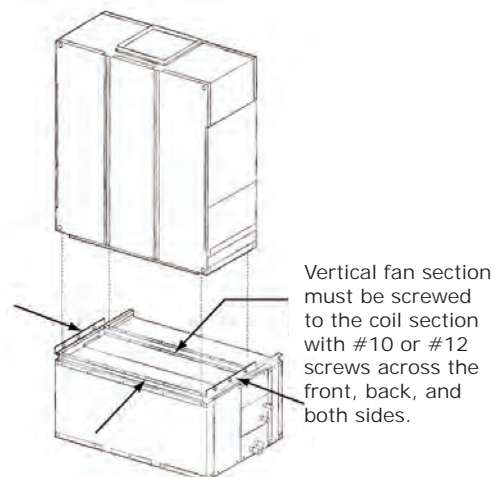
## Vertical Unit (Model BCVD) Installation

### Materials needed:

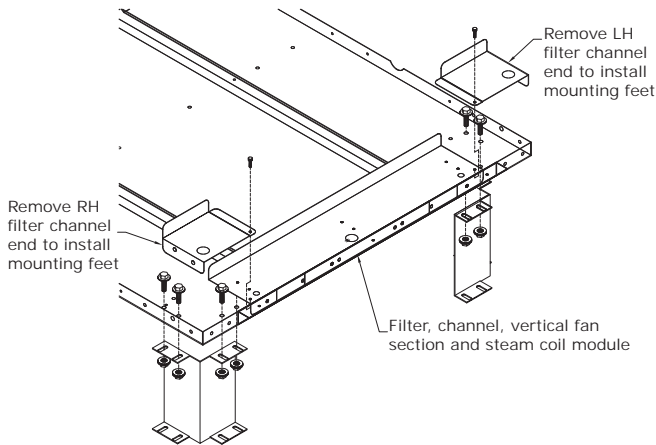
- 1/4-inch 20 grade 8 screws, lockwashers, and nuts (8 per mounting leg = 32 per unit, and 16 per accessory section)
- Flat washers (12 per mounting leg = 48 per unit, and 24 per accessory section)

Install vertical units on the floor. Units are provided with legs that are field-installed to help accommodate a U-trap on the drain connection, if necessary. For mounting leg installation, use 1/4-in.-20 grade 8 screws. A field-fabricated inlet plenum is not required. The unit is shipped in two pieces, and can be arranged in either a pre-swirl or counter-swirl inlet configuration (see the following figure).

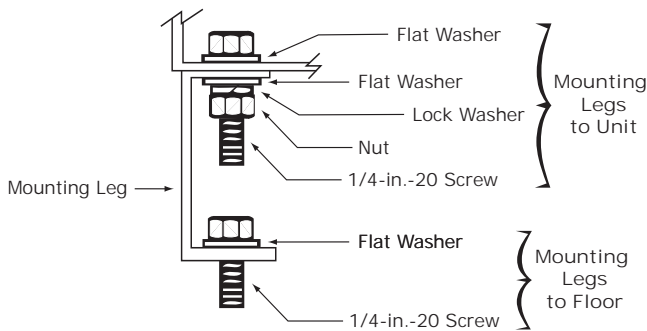
**Figure 27. Typical vertical unit installation**



**Figure 28. Mounting feet installation for vertical fan kit and steam coil module**



**Figure 29. Mounting leg installation**



\* Quantity = 4 per mounting leg = 16 per unit + 8 per accessory item

## Heating Coil Installation

**Note:** The hydronic heating coil option is factory installed in either the reheat or preheat position. Coils can be rotated for either right or left-hand connections.

If you need to rotate the hydronic heating coil option to change the coil connection side, follow the procedure below.

1. Remove both coil access panels.
2. Remove the coil and rotate to change connection position.
3. Exchange coil patch plates.
4. Knock out drain pipe connections on new coil hand access panel.
5. Plug old drain connections.

## Mixing Box Installation

### Materials provided:

- Mounting legs (2) for vertical units
- Interconnecting linkage, LH or RH attachment

### Materials needed:

- Grooved and extendible drive rods, 1/2-inch O.D. grooved
- #10 screws, for mounting mixing box to unit, steam coil module, or top/bottom access
- 1/4-inch 20 grade 8 screws for mounting leg installation

The mixing box option ships separately for field installation. It has two low-leak, opposed blade dampers and all necessary interconnecting linkage components for left or right hand attachment onto 1/2-inch O.D. grooved, extendible drive rods. Also, mounting legs are provided for floor mounting on a vertical unit. Knockouts are provided to suspend the mixing box from the ceiling horizontally.

### Installation Procedure

1. Support the mixing box independent of the unit in the horizontal position.
2. Install the mixing box as a sleeve around the duct collar of the filter frame. To attach the mixing box to the filter frame, insert screws through the matching the holes on all sides of the mixing box and filter frame.
3. Install the linkage, following the procedure below.

### Linkage Installation Procedure

1. Attach the linkage on either the right or left side of the mixing box following the procedure below.
2. Open the damper blades fully. Locate drive rods on the LH or RH side for linkage attachment. Loosen drive rod set screw, without removing.
3. Remove knockouts on side access panel adjacent to the drive rods.
4. Pierce a hole through the insulation at the knockouts to allow the drive rod to extend freely through side of mixing box. Cut away insulation sufficiently to allow drive rod to turn smoothly.
5. Extend drive rod end at desired position beyond side of unit. Tighten drive rod set screws.
6. Attach linkage and tighten all set screws. Note that neither hand levers are provided. However, mixing box actuators are a factory-provided option that ship inside the mixing box when ordered.
7. Position linkage so both sets of dampers operate freely and so that when one damper is fully open, the other is fully closed.

## Condensate Drain Connections

**Note:** It is the installer's responsibility to provide adequate condensate piping to prevent potential water damage to the equipment and/or building.

Size the main drain lines and trap them the same size as the drain connection, which is 3/4-inch schedule 40 PVC, 1.050 inch O.D. on BCHD/BCVD blower coils. The BCCD

blower coils have a rubber internal trap that has a 1.050 inch I.D. that can be connected to 3/4-inch schedule 40 PVC.

If drain pan removal is required, make the main and auxiliary drain connections with compression fittings. Follow the procedure below to remove the drain pan.

1. Remove the opposite side coil access panel.
2. Remove the drain pan clips.
3. Disconnect drain lines.
4. Remove the sheet metal screw.
5. Pull out drain pan through the opposite side.

**Note:** Prime drain traps to prevent the drain pan overflow.

Plug or trap the auxiliary connection to prevent air from being drawn in and causing carryover.

All drain lines downstream of the trap must flow continuously downhill. If segments of the line are routed uphill, this can cause the drain line to become pressurized. A pressurized drain line may cause the trap to back up into the drain pan, causing overflow.

## Duct Connections

All duct connections should be installed in accordance with the standards of the National Fire Protection Association (NFPA);

- Installation of Air Conditioning and Ventilation Systems other than Residence Type (NFPA 90A)
- Residence-Type Warm Air Heating and Air Conditioning Systems (NFPA 90B)

Make duct connections to the unit with a flexible material such as heavy canvas to help minimize noise and vibration. If a fire hazard exists, Trane recommends using Flexweave 1000, type FW30 or equivalent canvas. Use *three inches* for the return duct and *three inches* for the discharge duct. Keep the material loose to absorb fan vibration.

Run the ductwork straight from the opening for a minimum of 1 1/2 fan diameters. Extend remaining ductwork as far as possible without changing size or direction. Do not make abrupt turns or transitions near the unit due to increased noise and excessive static losses. Avoid sharp turns and use elbows with splitters or turning vanes to minimize static losses.

Poorly constructed turning vanes may cause airflow generated noise. Align the fan outlet properly with the ductwork to decrease duct noise levels and increase fan performance. Check total external static pressures against fan characteristics to be sure the required airflow is available throughout the ductwork.

To achieve maximum acoustical performance, minimize the duct static pressure setpoint.

# Piping and Connections

## NOTICE:

### Connection Leaks!

Failure to follow instructions below could result in damage to the coil header and cause connection leaks. Use a backup wrench when attaching piping to coils with copper headers. Do not use brass connectors because they distort easily.

## NOTICE:

### Over Tightening!

Failure to follow instructions below could result in damage to the coil header. Do not use teflon-based products for any field connections because their high lubricity could allow connections to be over tightened.

## NOTICE:

### Leakage!

Failure to follow instructions below could result in equipment damage. Properly seal all penetrations in unit casing from inner to outer panel in order to prevent unconditioned air from entering the module, as well as prevent water from infiltrating the insulation..

## General Recommendations

Proper installation, piping, and trapping is necessary to ensure satisfactory coil operation and to prevent operational damage:

- Support all piping independently of the coils.
- Provide swing joints or flexible fittings on all connections that are adjacent to heating coils to absorb thermal expansion and contraction strains.
- If the coil was ordered with factory-mounted controls, install the control valves. The valves ship separately.

**Note:** The contractor is responsible for supplying the installation hardware.

- For best results, use a short pipe nipple on the coil headers prior to making any welded flange or welded elbow type connections.
- Pipe coils counterflow to airflow.
- When attaching the piping to the coil header, make the connection only tight enough to prevent leaks.

**Note:** Do not exceed 200 foot-pounds of torque on supply and return connections. Do not exceed 25 foot-pounds of torque on drain and vent connections.

- Use pipe sealer on all thread connections.
- After completing the piping connections, seal around pipe from inner panel to outer panel.

## Grommet Installation

Grommets for piping headers ship loose in an accessory bag.

Figure 30. Grommets in accessory bag



Clean oil from panel before installing grommet onto headers to ensure good grommet adhesion.

Figure 31. Clean panel before installing grommets



To avoid heat damage:

1. Place grommet on the unit stub-outs without removing the adhesive backing.
2. Connect the incoming and outgoing pipe connections and before brazing, slide the grommets over the un-brazed joint away from the unit to avoid heat damage.
3. Braze the connections and allow to cool.
4. Slide the grommets back toward the unit.
5. Remove the adhesive backing and apply the grommets against the unit panel.

## Drain Pan Trapping (Models BCHD/BCVD)

**Note:** Model BCCD is internally trapped.

### ⚠ WARNING

#### No Step Surface!

Failure to follow instruction below could result in death or serious injury. Do not walk on the sheet metal drain pan. Walking on the drain pan could cause the supporting metal to collapse and result in the operator/technician falling.

### NOTICE:

#### Water Damage!

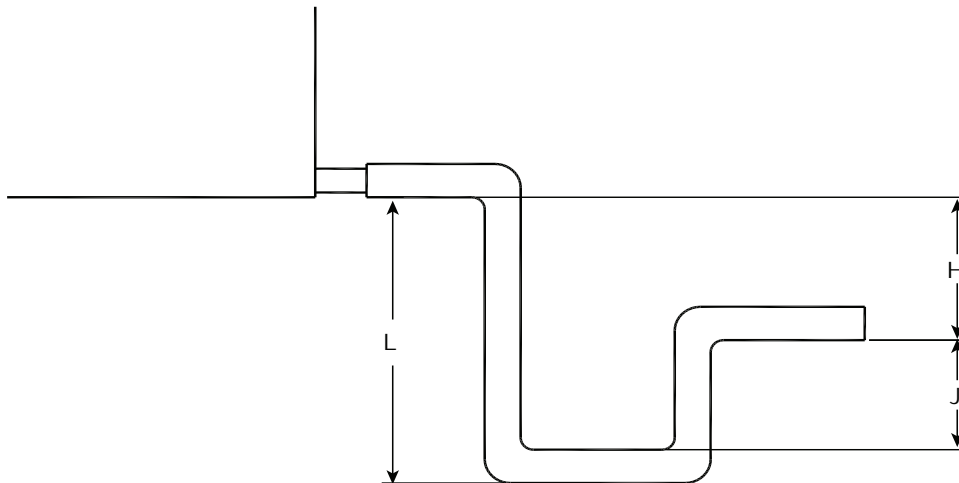
Failure to follow instructions below could result in equipment and property damage. Non-factory penetrations through the base of this unit are not allowed. Any penetration in the base of the unit may affect the water tight integrity of the unit and lead to water leaks into the conditioned space.

Condensate drain connections are provided on only one side of the coil section. Pitch the connection lines horizontal or downward toward an open drain. Trane recommends installing a plug to facilitate cleaning of the trap. The drain connection sizes are:

Unit size	NPT (national pipe thread) external connection
12-90	3/4-inch

The following figure illustrates the proper trapping, piping, and operation of the trap. Use the formula under the figure to determine the correct minimum depth for the condensate trap. If a section has a drain pan for cleaning purposes only, it does not need a trap; however, a cap or shutoff valve should be installed on the drain connection. Only sections handling condensate, such as a cooling coil section or moisture eliminator section, require a trap.

Figure 32. Drain pan trapping for negative pressure applications



Negative pressure  
Drain pan trapping for section  
under negative pressure

$L = H + J + \text{pipe diameter}$  where:  
 $H = 1 \text{ inch for each inch of negative pressure plus } 1 \text{ inch}$   
 $J = 1/2 H$

## Steam Coil Piping

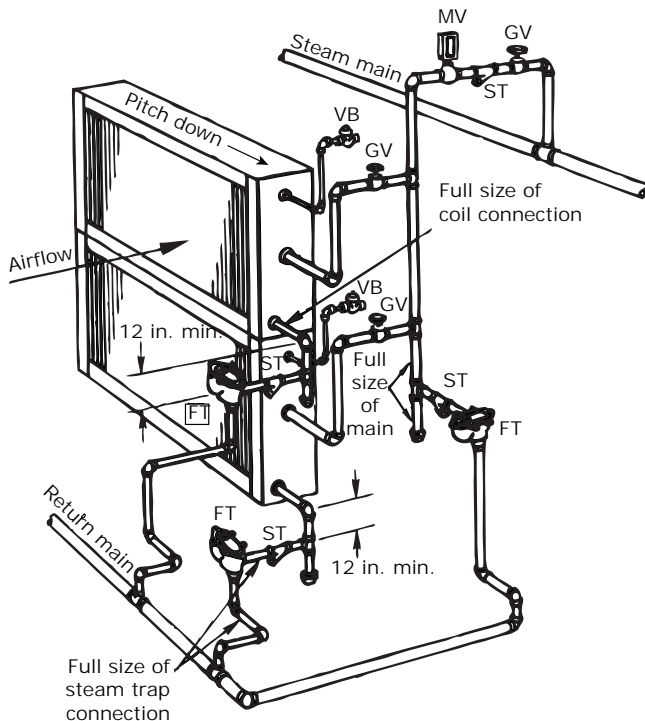
Air handlers fitted with steam coils have labeled holes for piping penetrations. The following figure illustrates a typical steam coil piping configuration. See the following table for the codes of system components in these figures.

The coil condensate return line must be piped full size of the condensate trap connection, except for a short nipple screwed directly into the coil header's condensate return tapping. Do not bush or reduce the coil return trapping size.

**Table 18. Code of system components for piping figures**

Code	System component
FT	Float and thermostatic steam trap
GV	Gate valve
OV	Automatic two-position (ON-OFF) control valve
VB	Vacuum breaker
ST	Strainer
AV	Automatic or manual air vent
MV	Modulating control valve

**Figure 33. Typical piping for Type NS steam coils and horizontal tubes for horizontal airflow**



### NOTICE:

#### Breaker Cracking Pressure!

Failure to follow instructions below could result in equipment damage.

The 1/2-inch NPT, 15 degree swing check valve vacuum breaker is recommended because other vacuum breakers, such as spring-loaded ball-check breakers, have cracking pressures as high as 1.25 inches Hg (17 inches of water). Vacuum breakers with fitting sizes smaller than 1/2 inch NPT are too small to relieve vacuum quick enough to ensure complete condensate drainage. Other types of swing check valve vacuum breakers are acceptable if the fittings size is not smaller than 1/2-inch NPT and the cracking pressure is not larger than 0.25 inches HG (3.5 inches of water).

To prevent coil damage, complete the following recommendations:

- Install a 1/2-inch NPT, 15 degree swing check valve vacuum breaker with cracking pressure of 0.25 inches Hg (3.4 inches water) or lower at the top of the coil. This vacuum breaker should be installed as close to the coil as possible.
- For coil type NS, install the vacuum breaker in the unused condensate return tapping at the top of the coil.
- Vent the vacuum breaker line to atmosphere or connect it into the return main at the discharge side of the steam trap

**Note:** Vacuum breaker relief is mandatory when the coil is controlled by a modulating steam supply or automatic two position (ON-OFF) steam supply valve. Vacuum breaker relief is also recommended when face-and-bypass control is used.

### NOTICE:

#### Coil Condensate!

Failure to follow instructions below could result in equipment damage. Condensate must flow freely from the coil at all times to prevent coil damage from water hammer, unequal thermal stresses, freeze-up and/or corrosion. In all steam coil installations, the condensate return connections must be at the low point of the coil.

Proper steam trap installation is necessary for satisfactory coil performance and service life. For steam trap installation:

1. Install the steam trap discharge 12 inches below the condensate return connection. Twelve inches provides sufficient hydrostatic head pressure to overcome trap losses and ensures complete condensate removal.
  - a. Use float and thermostatic traps with atmospheric pressure gravity condensate return, with automatic controls, or where the possibility of low-pressure

supply steam exists. (Float and thermostatic traps are recommended because of gravity drain and continuous discharge operation.)

- b. Use bucket traps only when the supply steam is not modulated and is 25 psig or higher.

**Note:** Trane steam coils require a minimum of 2 psi of pressure to assure even heat distribution.

2. Trap each coil separately to prevent holding up condensate in one or more of the coils.
3. Install strainers as close as possible to the inlet side of the trap.
4. If installing coils in series airflow, control each coil bank independently with an automatic steam-control valve. Size the traps for each coil using the capacity of the first coil in direction of airflow.
5. Use a modulating valve that has linear flow characteristics to obtain gradual modulation of the coil steam supply.

**Note:** Do not modulate systems with overhead or pressurized returns unless the condensate is drained by gravity into a receiver, vented to atmosphere, and returned to the condensate pump.

6. Pitch all supply and return steam piping down 1 inch for every 10 feet in the direction of the steam or condensate flow.

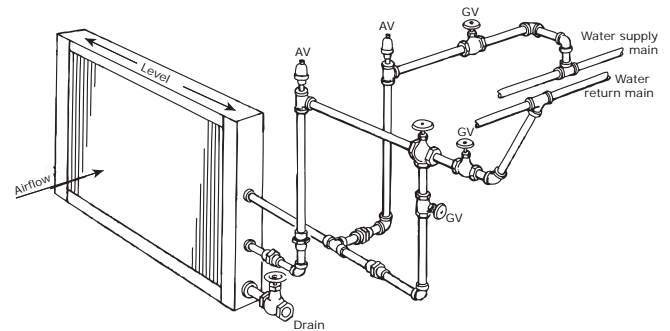
**Note:** Do not drain the steam mains or take-offs through the coils. Drain the mains ahead of the coils through a steam trap to the return line.

7. Ensure overhead returns have 1 psig of pressure at the steam trap discharge for every 2 feet of elevation for continuous condensate removal.

## Water Coil Piping

Water coils are self-venting only if the water velocity exceeds 1.5 feet per second (fps) in the coil tubes. See the unit submittals for coil water velocity.

**Figure 34. Typical piping for one-row water coil**

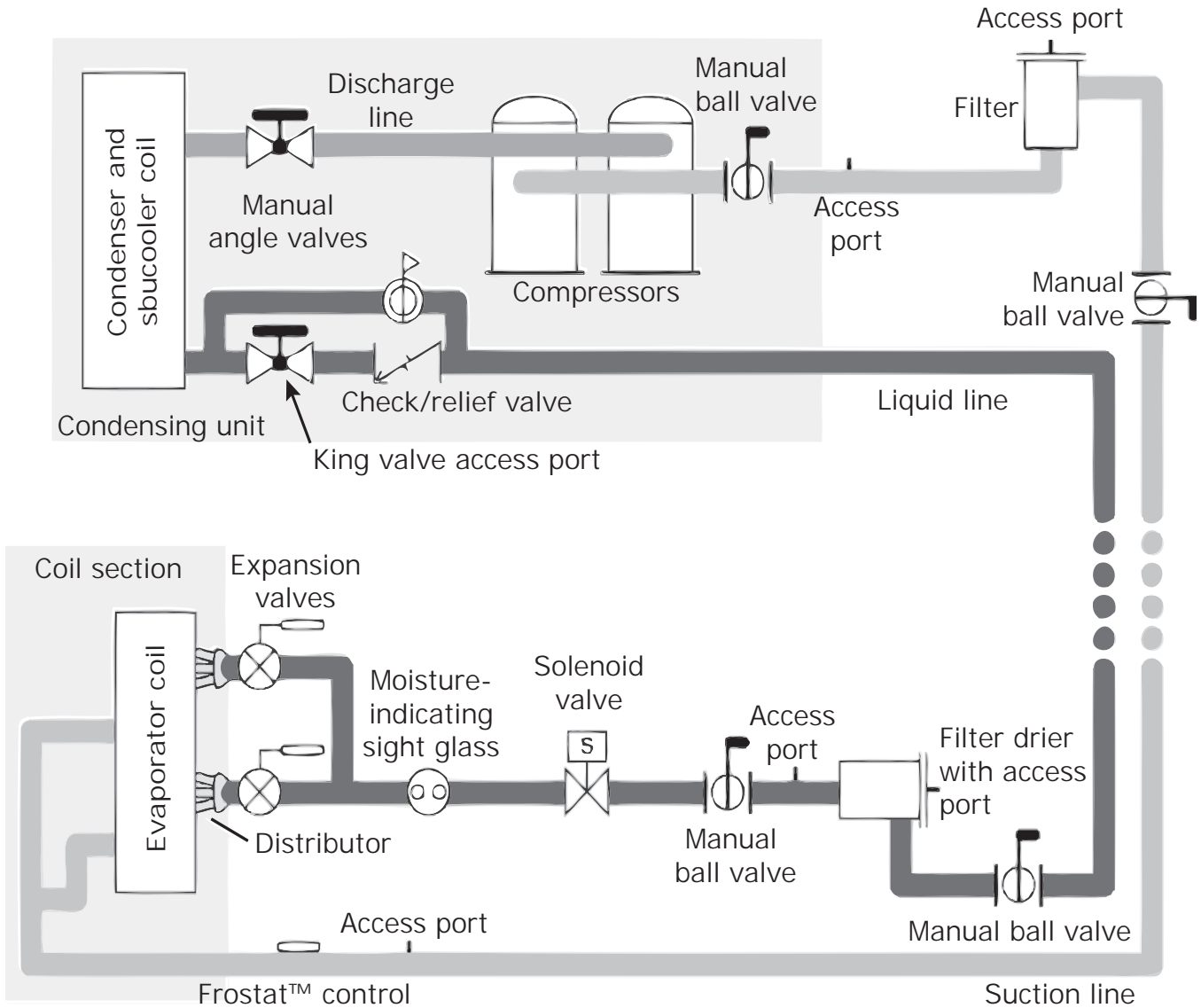


## Refrigerant Coil Piping

**Note:** Refer to for information on handling refrigerants.

The following figure illustrates an example of a split-system component arrangement. Use it to determine the proper, relative sequence of the components in the refrigerant lines that connect the condensing unit to an evaporator coil.

**Figure 35. Example of placement for split-system components**



## Liquid Lines

### Line Sizing

Properly sizing the liquid line is critical to a successful split-system application. The selected tube diameter must provide at least 5°F [2.7°C] of subcooling at the expansion valve throughout the operating envelope. Increasing the size of the liquid line will not increase the available subcooling.

### Routing

Install the liquid line with a slight slope in the direction of flow so that it can be routed with the suction line. Minimize tube bends and reducers because these items tend to increase pressure drop and to reduce subcooling at the expansion valve. Liquid line receivers, other than those that are factory-installed, are not recommended.

### Insulation

The liquid line is generally warmer than the surrounding air, so it does not require insulation. In fact, heat loss from the liquid line improves system capacity because it provides additional subcooling. However, if the liquid line is routed through a high-temperature area, such as an attic or a mechanical room, insulation would be required.

### Components

Liquid-line refrigerant components necessary for a successful job include a filter drier, access port, solenoid valve, moisture-indicating sight glass, expansion valve(s), and ball shutoff valves. [Figure 35](#) illustrates the proper sequence for positioning them in the liquid line. Position the components as close to the evaporator as possible.

- **Filter drier.** There is no substitute for cleanliness during system installation. The filter drier prevents residual contaminants, introduced during installation, from entering the expansion valve and solenoid valve.
- **Access port.** The access port allows the unit to be charged with liquid refrigerant and is used to determine subcooling. This port is usually a Schraeder® valve with a core.
- **Solenoid valve.** In split systems, solenoid valves isolate the refrigerant from the evaporator during off cycles; under certain conditions, they may also trim the amount of active evaporator as compressors unload. Generally, the “trim” solenoid valve is unnecessary for VAV comfort-cooling applications, and is only required for constant-volume applications when dehumidification is a concern.  
In split systems with micro-channel heat exchanger condensers (MCHE), solenoid valves isolate the refrigerant from the evaporator during the off cycles. Trim solenoids cannot be used with MCHE.

**Note:** Trane condensing units with MCHE no longer employ pump-down, but isolation solenoids are required. The suggested solenoid uses a 120-volt

service and requires code-compliant wiring to the condensing unit.

- **Moisture-indicating sight glass.** Be sure to install one moisture-indicating sight glass in the main liquid line. The only value of the sight glass is its moisture indication ability. Use actual measurements of temperature and pressure—not the sight glass—to determine subcooling and whether the system is properly charged. The moisture indicator/sight glass must be sized to match the size of the liquid line at the thermal expansion valve.

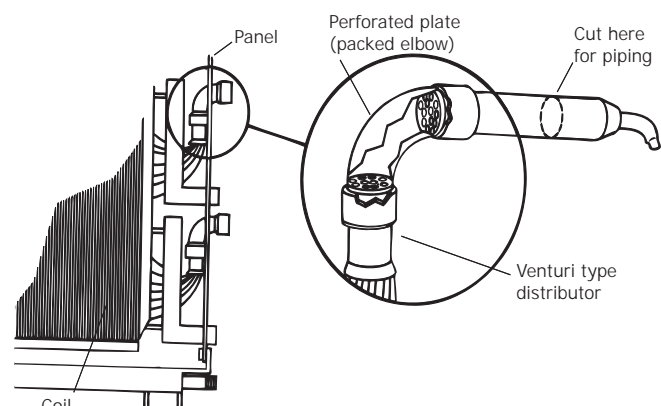
### NOTICE:

#### Valve Damage!

**Failure to protect the valve from high temperatures could result in damage to internal components. Disassemble the thermal expansion valve before completing the brazing connections. If necessary, wrap the valve in a cool, wet cloth while brazing.**

- **Thermal expansion valve.** The expansion valve is the throttling device that meters the refrigerant into the evaporator coil. Metering too much refrigerant floods the compressor; metering too little elevates the compressor temperature. Choosing the correct size and type of expansion valve is critical to assure it will correctly meter refrigerant into the evaporator coil throughout the entire operating envelope of the system. *Correct refrigerant distribution into the coil requires an expansion valve for each distributor.* The thermal expansion valve must be selected for proper size and capacity. The size of the expansion valve should cover the full range of loadings. Check that the valve will successfully operate at the lightest load condition. For improved modulation, choose expansion valves with balanced port construction and external equalization. Cut the process tube and cap assembly from the liquid connection as shown in the following figure and install the expansion valve directly to the liquid connections.

**Figure 36. Type F refrigerant coil with packed elbow**





## Piping and Connections

---

- **Ball shutoff valves.** Adding manual, ball-type shutoff valves upstream and downstream of the filter simplifies replacement of the filter core.

## Suction Lines

### Line sizing

Proper line sizing is required to guarantee the oil returns to the compressor throughout the system's operating envelope. At the same time, the line must be sized so that the pressure drop does not excessively affect capacity or efficiency. To accomplish both objectives, it may be necessary to use two different line diameters: one for the horizontal run and for the vertical drops, and another for the vertical lifts (risers).

### Routing

To prevent residual or condensed refrigerant from "free-flowing" toward the compressor during the off cycle, install the suction line so it slopes by  $\frac{1}{4}$  inch to 1 inch per 10 feet of run toward the evaporator.

When the application includes a suction riser, oil must be forced to travel the height of the riser. Riser traps are unnecessary in the suction line. They will add pressure drop. Double risers must not be used. They not only add pressure drop, but can hold great amounts of oil - oil better used in the compressor.

If a suction riser is properly sized, oil will return to the compressor regardless of whether a trap is present. If a suction riser is oversized, adding a trap will not restore proper oil entrainment.

### Avoid Underground Refrigerant Lines

Refrigerant condensation during the off cycle, installation debris inside the line (including condensed ambient moisture), service access, and abrasion/corrosion can quickly impair reliability.

### Insulation

Any heat that transfers from the surrounding air to the cooler suction lines increases the load on the condenser (reducing the system's air-conditioning capacity) and promotes condensate formation. After operating the system and testing all fittings and joints to verify that the system is leak-free, insulate suction lines to prevent heat gain and unwanted condensation.

### Components

Installing the suction line requires field installation of these components: a filter, access port, and a Froststat™ control when the refrigerant coil is used with Trane condensing units. Position them as close to the compressor as possible.

**Note:** Placement of the Froststat control is illustrated in [Figure 35, p. 36](#).

- **Filter:** The suction filter prevents contaminants, introduced during installation, from entering the

compressor. For this reason, the suction filter should be the replaceable-core type, *and* a clean core should be installed after the system is cleaned up.

- **Access port:** The access port is used to determine suction pressure. This port is usually a Schraeder valve with a core.
- **Froststat™ coil frost protection:** The Froststat control is the preferred method for protecting evaporator coils from freezing when the refrigerant coil is used with Trane condensing units. It senses the suction-line temperature and temporarily disables mechanical cooling if it detects frost conditions. The control is mechanically attached to the outside of the refrigerant line, near the evaporator, and wired to the unit control panel.
- **Ball shutoff valve:** Adding manual, ball-type shutoff valves upstream and downstream of the filter simplifies replacement of the filter core.

## Expansion Valves

Expansion valves meter refrigerant into the evaporator under controlled conditions. If there is too much refrigerant, the refrigerant will not completely vaporize and the remaining liquid will slug the compressor. If there is too little refrigerant, there may not be enough cooling for the compressor.

Expansion valve requirements vary based on condensing unit design. Consult the product literature for the condensing unit to be used for proper valve selection.

## Remodel, Retrofit, or Replacement

Inevitably, older condensing units and evaporator systems need to be replaced or retrofitted. Due to the phase-out of many of these older refrigerants, the major components for those older units or systems may no longer be available. The only option will be to convert the system to R-410A, POE oil, and R-410A components.

When upgrading an existing refrigerant split system due to remodel, retrofit, or replacement, the entire system must be reviewed for compatibility with R-410A and POE oil. Each and every part of the split HVAC system **MUST** be compatible with the properties of R-410A refrigerant and POE oil. In addition, ensure the existing electrical service is adequate for the product being installed.

**⚠ WARNING****R-410A Refrigerant under Higher Pressure than R-22!**

Failure to use proper equipment or components as described below, could result in equipment failing and possibly exploding, which could result in death, serious injury, or equipment damage. The units described in this manual use R-410A refrigerant which operates at higher pressures than R-22. Use **ONLY R-410A rated service equipment or components with these units. For specific handling concerns with R-410A, please contact your local Trane representative.**

Every part of an existing split system needs to be analyzed to determine if it can be reused in an R-410A and POE oil system:

- R-22 condensing units will not work with R-410A; they must be replaced.
- Most older evaporator coils were not pressure- and cycle-rated for R-410A pressures. If they weren't, they will need to be replaced. If they were properly pressure-rated for R-410A, existing coils must be modeled to determine if they will meet capacity requirements, are properly circuited, have correctly sized distributor tubes, and employ acceptable distributors and orifices.
- The required R-410A line sizes may be different than the existing line sizes. The lines need to be re-sized and compared to existing lines for reusability.
- Suction lines 2-5/8 OD and smaller of type L copper are suitable for use with R-410A. Suction lines 3-1/8 OD must use type K or thicker wall.
- Discharge lines, liquid lines, heat pump vapor lines, and hot gas bypass lines 1-3/8 OD and smaller of type L copper are suitable for use with R-410A. These same lines sized at 1-5/8 OD or 2-1/8 OD must use type K or thicker wall.
- Expansion valves need to be reselected. Expansion valves are refrigerant specific.

- Any gasket or o-ring should be replaced. Shrinkage of the original seal may occur after an HFC conversion, potentially causing a refrigerant leak. Components commonly affected are Schraeder cores, solenoid valves, ball valves, and flange seals. But *all* external seals in contact with refrigerant should be viewed as potential leak sources after a retrofit.
- All other valves, filters, valve packing, pressure controls, and refrigeration accessories must be researched through their manufacturer for compatibility with the pressures of an R-410A system, and for their compatibility with the newer POE oil.
- For the best performance and operation, the original mineral oil should be removed from the components of the system that are not being replaced. Any component of the system that is suspected of trapping oil (piping, traps, and coil), should be dismantled, drained, and reassembled. After all components have been drained, the amount of residual mineral oil will have a negligible effect on performance and reliability.

**NOTICE:****Compressor Damage!**

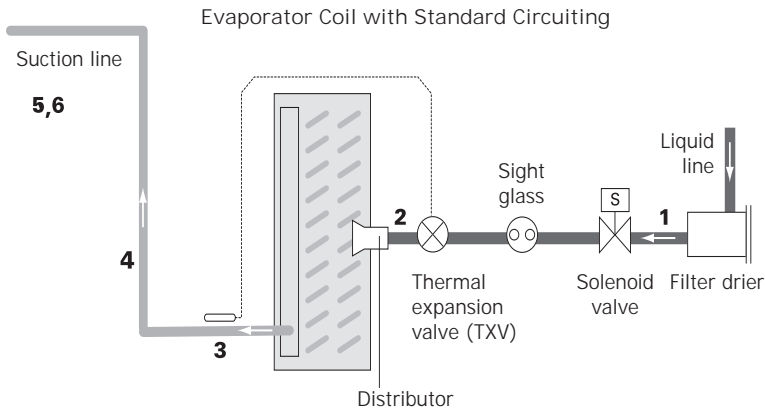
**POE oil is hygroscopic – it absorbs water directly from the air. This water is nearly impossible to remove from the compressor oil and can result in compressor failures.**

**To prevent POE oil from absorbing water, the system should not remain open for longer than necessary. When open, dry nitrogen should flow through the piping. Only new oil containers should be used for service and maintenance. Always use the smallest container size required for the job requirements. Always leave the oil container tightly sealed until time of use. Do not reuse oil that has been opened.**

All Codes take precedence over anything written here.

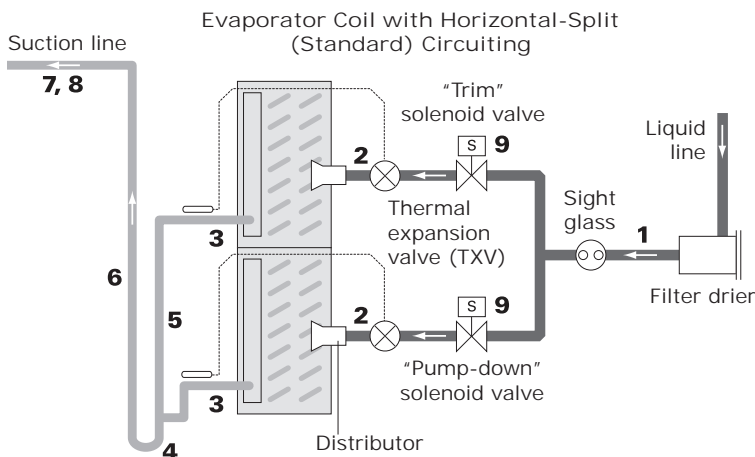
## Field-Installed Evaporator Piping

**Figure 37. Typical single-circuit condensing unit: evaporator coil with one distributor**



1. Pitch the liquid line slightly—1 inch/10 feet—so that the refrigerant drains toward the evaporator.
2. Provide one expansion valve per distributor.
3. Slightly pitch the outlet line from the suction header toward the suction riser—that is, 1 inch/10 feet in the direction of flow. Use the tube diameter that matches the suction-header connection.
4. Use the tube diameter recommended in the condensing unit application manual for a vertical rise. Ensure that the top of the riser is higher than the evaporator coil.
5. Pitch the suction line slightly—1 inch/10 feet—so the refrigerant drains toward the evaporator.
6. Insulate the suction line.

**Figure 38. Typical single-circuit condensing unit: evaporator coil with two distributors**



1. Pitch the liquid line slightly—1 inch/10 feet—so the refrigerant drains toward the evaporator.
2. Provide one expansion valve per distributor.
3. Slightly pitch the outlet line from the suction header toward the suction riser—1 inch/10 feet in the direction of flow. Use the tube diameter that matches the suction-header connection. Use a double-elbow configuration to isolate the TXV bulb from other suction headers.
4. This looks like a trap, but is actually due to the requirement that the refrigerant gas leaving the coil flows downward, past the lowest suction-header outlet, before turning upward.
5. Use the “horizontal” tube diameter as specified in the condensing unit application manual.
6. Use the tube diameter recommended for a vertical rise as specified in the condensing unit application manual. Assure the top of the riser is higher than the evaporator coil.
7. Pitch the suction line slightly—1 inch/10 feet—so that the refrigerant drains toward the evaporator.
8. Insulate the suction line.
9. Only use a “trim” solenoid valve for constant-volume, humidity-sensitive applications. For all other applications, install a single solenoid valve (the “pumpdown” solenoid valve) between the liquid-line filter drier and the sight glass.

**Note:** Due to reduced coil volume in condensing units with micro-channel heat exchanger condenser, do not use trim solenoid valves for these units.



# Installation - Controls

## Control Options

Available control options are:

- Fan speed control (provided when no control package is selected)
- Customer-supplied terminal interface (CSTI)
- Thermostat
- Tracer® ZN520 controller
- Tracer® UC400-B controller with Air-Fi® Wireless Communications Interface

## Fan Speed Switch

The manual fan mode switch is available for units that do not have Trane factory-mounted control packages. This four-position switch (off, high, medium, low) allows manual fan mode selection. This wall-mounted option is low-voltage and has three 24 volt relays using a factory-wired transformer and relays to control the fan motor.

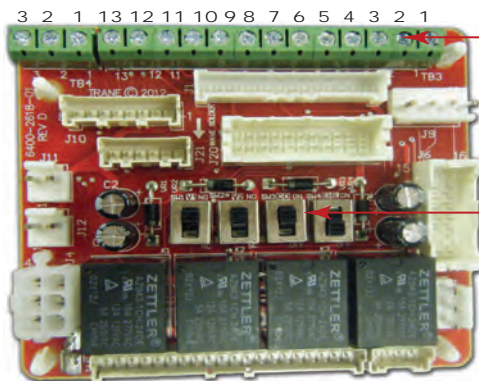
Figure 39. Fan speed switch



## Customer Supplied Terminal Interface (CSTI)

The control interface is intended to be used with a field-supplied, low-voltage thermostat or controller. The control box contains a relay board which includes a line voltage to 24-volt transformer, quiet contactors (for electric heat units), and an optional disconnect switch. All end devices are wired to a low-voltage terminal block and are run-tested, so the only a power connection and thermostat connection is needed to commission the unit. Changeover sensors and controls are provided whenever a change-over coil is selected. When N.O. valves are selected, inverting relays are provided for use with standard thermostats.

Figure 40. CSTI adapter board and field connections



Customer low-voltage interface for fan speeds, variable fan speed, and 24 Vac supply, valve control, EH control, damper control, condensate overflow status

Valve(s), electric heat, and changeover configuration switches (factory-set)

- |     |                      |
|-----|----------------------|
| 1.  | VSP 10V              |
| 2.  | VSP 0-10V            |
| 3.  | VSP DC COM           |
| 1.  | 24 Vac B (hot)       |
| 2.  | 24 Vac Y (gnd)       |
| 3.  | High                 |
| 4.  | Medium               |
| 5.  | Low                  |
| 6.  | V1Op/Cooling         |
| 7.  | V1CI (not std)       |
| 8.  | Not used             |
| 9.  | Not used             |
| 10. | V2Op/EH1St/Heating   |
| 11. | V2CI/EH2St (not std) |
| 12. | Damper Open          |
| 13. | Dmp CI (not std)     |

## Installation - Controls

The CSTI adapter board provides all the hookups as the standard adapter board, but in addition, provides hookups for valve control (main and auxiliary coils), electric heat control, and damper control. Screw terminal blocks provide convenient access to fan controls and to end device control. In addition, a courtesy 10 VDC supply is provided for use with an external potentiometer or rheostat. The 10 VDC supply supports up to 10 mA draw.

TB3 (right 13 positions) is normally used to provide:

- 24 Vac supply to a wall fan speed switch or
- 24 Vac supply to a field-installed unit-mounted controller, or a wall-mounted controller or thermostat
- Inputs (returns) for thermostatic fan control: High, Medium, and Low
- Inputs (returns) for cooling/heating requests
- Inputs (returns) for electric heat requests
- Inputs (returns) for damper operation requests

TB4 (left three positions) is normally used to control the system with a 0–10 VDC input from a thermostat/controller with a variable speed output, or a fan control rheostat.

The terminal block functional assignments and polarity are shown for reference only, and the schematics that ship with each unit should be consulted before wiring. Wiring assignments are configured for each unit.

## CSTI Adapter Board Configuration

### ⚠ CAUTION

#### Burn Hazard!

Failure to follow this instruction could result in the unit overheating and becoming hot to the touch, which could result in minor or moderate injury, and/or equipment damage. If SW4 is turned off, the factory/customer controller/thermostat will be able to actuate the electric heat while hot water is available or if the fans have failed. This switch should NOT be turned off if the unit schematic indicates that it should be on, to prevent overheating of the unit (due to simultaneous electric heat and hydronic heat actuation, or failure of the fan) and to use the preferred hydronic heating over electric heat.

For CSTI units, the board mounted switches have to be set appropriately to enable the desired functionality.

Figure 41. CSTI board-mounted switches



Table 19. CSTI adapter board: switch functions

Switch (L-R)	SW1	SW2	SW3	SW4
Function	Valve one operation logic	Valve two operation logic	Changeover Function	Electric Heat / Fan Proving Function
UP position (towards terminal strip)	Normally Open Valve	Normally Open Valve	Changeover Function ON	Electric Heat / Fan Proving Function
DOWN position (towards black relays)	Normally Closed Valve	Normally Closed Valve	Changeover Function OFF	Electric Heat / Fan Proving Function

- All switches are factory-set based on customer configuration of the unit model number. The unit will function correctly as shipped; however, the switch functions and positions are depicted for customer convenience and for service and troubleshooting aids.
- SW3 and SW4 work in conjunction with settings on the motor control board controller. Simple activation of changeover and electric heat lockout function may not work correctly unless the motor control board is configured to perform these functions.
- Customers are advised to locate the changeover coil temperature sensor on the bypass line if possible, to avoid measuring standing water temperature.
- If a 4-pipe unit with changeover function is selected, the heating input will drive the main coil if hot water is detected, but will always drive the auxiliary coil or electric heat (where available).
- Where electric heat is available with a changeover coil, the electric heat is factory-configured to be deactivated if there is hot water available and if there is a fan failure.

The CSTI board comes with courtesy valve inversion relays that allow both normally open and normally closed two-position valves to be used with simple thermostats that do not have the configurability to adapt to the customer choice of valves. Independent switches, SW1 and SW2, are provided for 2-pipe or 4-pipe units, or 2-pipe units with an optional reheat coil. The functions of SW1 and SW2 is downstream of the changeover function (SW3 and motor control board). Decisions made by the changeover circuits will be flowed to the inversion circuits, if they are selected.

SW3 enables or disables the changeover function for 2-pipe changeover coil units, or 4-pipe units where the coil has both a heating/cooling circuit and a heating circuit piped internally. If SW3 is turned off, the changeover function will be disabled, and the unit will then be configured as a cooling only coil, a heating only coil, or a combination of cooling only/heating only coil. Thus, customer cooling requests will drive the main valve, and heating requests will drive the auxiliary valve.

The changeover function is designed to work with customer controllers that request heating or cooling (based on customer request), but have coil water temperatures that are “changed over” from heating to cooling (or cooling to heating) depending on the season and the building equipment available. Customer thermostats **MUST** be hooked to the correct terminal strip locations (V1 and V2) for the changeover function to work.

### Cooling

In general, the (CSTI) changeover function will provide cooling if:

- A unit is factory configured with a changeover coil (cooling/heating) as the only coil or as the main coil portion.
- SW3 on the CSTI adapter board is turned on, and the **FP<sub>RU</sub>** parameter set to **EH<sub>L</sub>** or **EH<sub>FS</sub>** to use the changeover functions.
  - **EH<sub>L</sub>** parameter should be chosen if the unit has a changeover coil without electric heat.
  - **EH<sub>FS</sub>** parameter should be chosen if the unit has a changeover coil with electric heat. Generally, this will perform the same as the **EH<sub>L</sub>** parameter but will in addition, disable the heating function on electric heat and on the changeover coil heat if there are fan failures. The auxiliary heating coil valve will continue to respond to customer heating requests.
- The motor control board has sensed that there is cold water available on the supply/bypass line for the changeover coil. In this case, “cold” water is inferred by the motor control board if:
  - A 10K NTC thermistor (similar to Trane part number X13790374010) is wired properly to the motor control board, through the crossover cables and CSTI adapter boards.
  - The input impedance of the thermistor circuit must be set correctly (the **A<sub>IPU</sub>** parameter should be set to **in** for CSTI units).
  - The temperature sensed is lower than the **A<sub>i2i</sub>** parameter.
  - The **A<sub>i2b</sub>** parameter is higher than the **A<sub>i2i</sub>** parameter.
  - The temperature is not in the dead-band between the **A<sub>i2b</sub>** parameter and the **A<sub>i2i</sub>** parameter (in this case, previous state will be retained).
- The customer thermostat is properly hooked up the input strip 1TB3, and is requesting cooling input (V1) based on the customer cooling setpoint being lower than the space temperature.

### Heating

In general, the (CSTI) changeover function will provide heating if:

- A unit is factory-configured with a changeover coil (cooling/heating) as the only coil or as the main coil portion.
  - SW3 on the CSTI adapter board is turned on, and the **FP<sub>RU</sub>** parameter set to **EH<sub>L</sub>** or **EH<sub>FS</sub>** to use the changeover functions.
    - **EH<sub>L</sub>** parameter should be chosen if the unit has a changeover coil without electric heat.
    - **EH<sub>FS</sub>** parameter should be chosen if the unit has a changeover coil with electric heat. Generally, this will perform the same as the **EH<sub>L</sub>** parameter but will in addition, disable the heating function on electric heat and on the changeover coil heat if there are fan failures. The auxiliary heating coil valve will continue to respond to customer heating requests.
  - The motor control board has sensed that there is hot water available on the supply/bypass line for the changeover coil. In this case, “hot” water is determined if:
    - A 10K NTC thermistor (similar to Trane part number X13790374010) is wired properly to the motor control board, through the crossover cables and CSTI adapter boards.
    - The input impedance of the thermistor circuit must be set correctly (the **A<sub>IPU</sub>** parameter should be set to **in** for CSTI units).
    - The temperature sensed is higher than the **A<sub>i2b</sub>** parameter.
    - The **A<sub>i2b</sub>** parameter is higher than the **A<sub>i2i</sub>** parameter.
      - a. The temperature is not in the dead-band between the **A<sub>i2b</sub>** parameter and the **A<sub>i2i</sub>** parameter (in this case, previous state will be retained).
  - The customer thermostat is properly hooked up the input strip 1TB3, and is requesting heating input (V2) based on the customer heating set point being higher than the space temperature.
  - The heating input on 1TB3 will drive the main changeover coil IF conditions 1–4 are satisfied, but will always drive the auxiliary coil valve (if present). Electric heat will be locked out (where present) if hot water is available since SW4 will be factory set to “ON” in these units.
- SW4 selects the electric heat lockout function, where we will lock out the electric heat circuit based on either:
- The presence of hot water in the changeover coil section (if the **FP<sub>RU</sub>** parameter is set to **EH<sub>L</sub>**).
  - Abnormal behavior of the fan/s (if the **FP<sub>RU</sub>** parameter is set to **F<sub>nSt</sub>**).
  - Or a combination of both the presence of hot water or abnormal behavior of the fan/s (if the **FP<sub>RU</sub>** parameter is set to **EH<sub>FS</sub>**).

## Installation - Controls

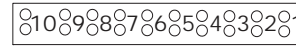
- The preceding three examples depend on the inference of the motor control board that hot water is present. In this case, "hot" water is determined if:
  - The temperature sensed is higher than the **A 12b** parameter.
  - The **A 12b** parameter is higher than the **A 12i** parameter.
  - The temperature is not in the dead-band between the **A 12b** parameter and the **A 12i** parameter (in this case, previous state will be retained).
  - The input impedance of the thermistor circuit must be set correctly (the **A 1PU** parameter should be set to **1n** for CSTI units).

## Thermostat

The thermostat is a wall-mounted, field-installed option. It can provide three-speed control.

### Thermostat Installation

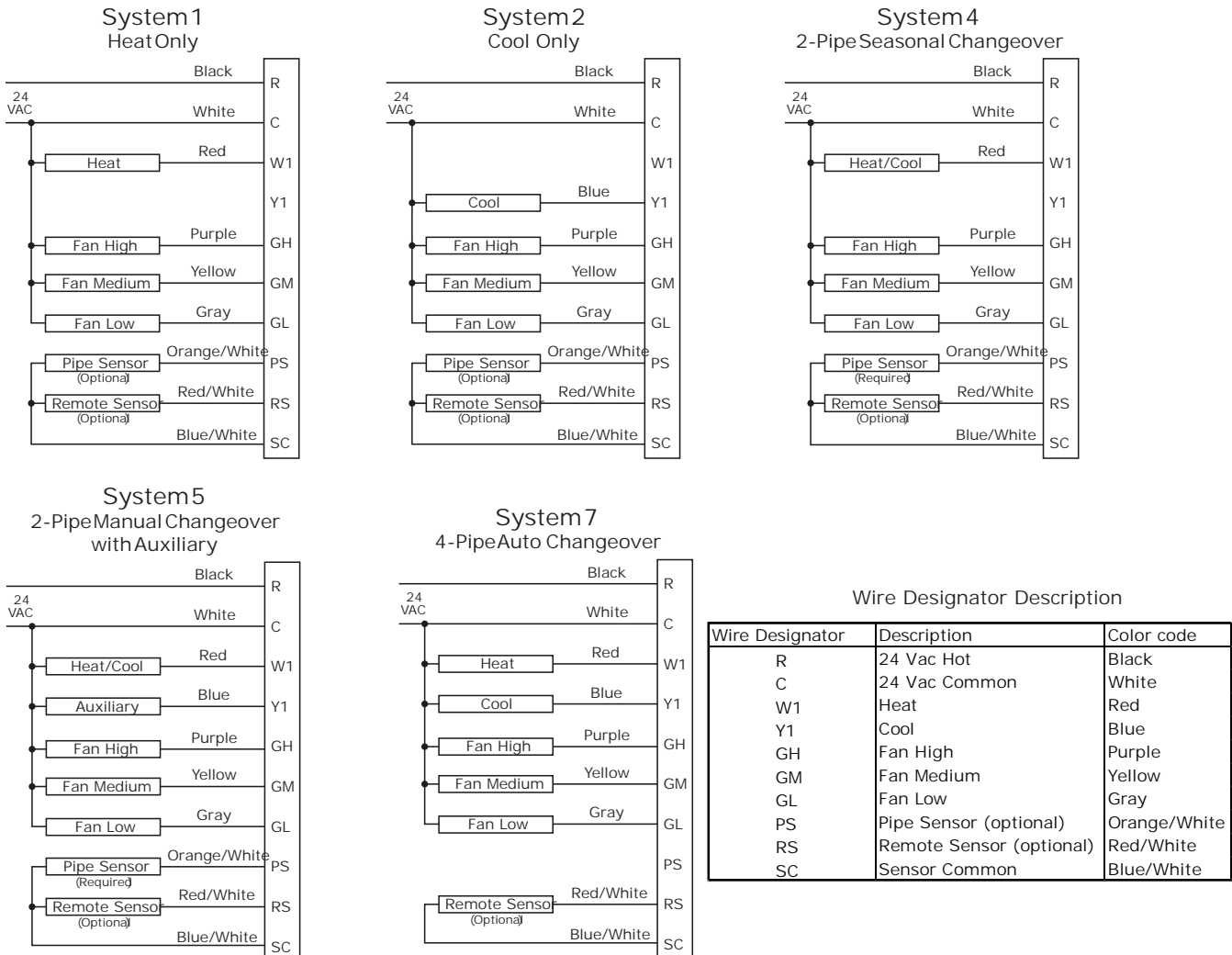
Figure 42. Terminal block



Terminal Block

- 24 Vac
- N
- Fan High
- Fan Med
- Fan Low
- Cool/Cool or Heat
- Heat/Aux Heat
- Entering Water sensor
- Common
- N/A

Figure 43. Thermostat wiring diagram



**⚠ WARNING****Electrical Shock Hazard**

**Turn off power at the main service panel by removing the fuse or switching the appropriate circuit breaker to the OFF position before removing the existing thermostat.**

**Important:** *Thermostat installation must conform to local and national building and electrical codes and ordinances.*

**Note:** *Mount the thermostat about five feet above the floor. Do not mount the thermostat on an outside wall, in direct sunlight, behind a door, or in an area affected by a vent or duct.*

1. Turn off power by removing the fuse or switching the appropriate circuit breaker off.
2. To remove cover, remove screw and pull gently at the seam at the top.
3. Set thermostat away from working area.
4. Align thermostat base with junction box mounting holes and feed the control wires through hole.
5. Use supplied screws to mount thermostat base to junction box.
6. Wire nut the thermostat wires to your system wires.
7. Gently tug wire to be sure of proper connection. Double check that each wire is connected to the proper terminal.
8. Snap thermostat to base that is mounted on the wall. Refasten with screw.
9. Turn on power to the system at the main service panel.
10. Test thermostat operation as described in "Testing the Thermostat".

**⚠ CAUTION**

**Be sure exposed portion of wires does not touch other wires.**

## Tracer<sup>®</sup> ZN520 Controller

The Tracer<sup>®</sup> ZN520 controller is a factory-installed, -tested and -commissioned LonTalk<sup>®</sup> control designed to provide control of Trane products. The discrete speed controller can also be used in a stand-alone application. Features include:

- Automatic fan-speed reset
- Automatic ventilation reset
- Active dehumidification
- Manual output test
- Filter maintenance
- Master slave
- Water valve override

- Freeze avoidance
- Interoperability

Three generic I/O ports

The Tracer<sup>®</sup> ZN520 controller is designed to be used in the following applications:

- As part of a Tracer<sup>®</sup> SC or Tracer<sup>®</sup> Summit building automation system (BAS), the Tracer<sup>®</sup> ZN520 becomes an important part of the Tracer<sup>®</sup> control system.
- The Tracer<sup>®</sup> ZN520 can function as a completely stand-alone controller in situations where a BAS is not present.
- For situations when a non-Trane BAS is present, the Tracer<sup>®</sup> ZN520 can be used as an inter-operable unit controller.

### ZN520 Controllers

Tracer<sup>®</sup> ZN520 controllers are LonTalk<sup>®</sup> devices that interface with the Tracer<sup>®</sup> SC or Tracer<sup>®</sup> Summit building automation system (BAS). Reference the unit wiring diagram or submittals.

Ground shields at each Tracer<sup>®</sup> ZN520, taping the opposite end of each shield to prevent any connection between the shield and another ground.

**Note:** *For more detailed information, refer to:*

- CNT-SVX04\*-EN Tracer<sup>®</sup> ZN520 Unit Controller: *Installation, Operation and Programming Guide* for the communication wiring diagram

### Communication Wire Specifications

Communication wire must conform to the following specification:

- Shielded twisted pair 18 AWG
- Capacitance 23 (21–25) picofarads (pF) per foot
- Listing/Rating—300 V 150C NEC 725-2 (b) Class 2 Type CL2P
- Trane Part No. 400-20-28 or equivalent

**Note:** *Communication link wiring is a shielded, twisted pair of wire and must comply with applicable electrical codes.*

Controller communication-link wiring must be low capacitance, 18-gauge, shielded, twisted pair with stranded, tinned-copper conductors. For daisy chain configurations, limit the wire run length to 5,000 ft. Truck and branch configurations are significantly shorter. LonTalk wire length limitations can be extended through the use of a link repeater.

### General Wiring Guidelines

Follow these general guidelines when installing communication wiring on units with a Tracer<sup>®</sup> ZN510 or ZN520 controller:

- Maintain a maximum 5000 ft. aggregate run.



## Installation - Controls

- Install all communication wiring in accordance with the NEC and all local codes.
- Solder the conductors and insulate (tape) the joint sufficiently when splicing communication wire. Do not use wire nuts to make the splice.
- Do not pass communication wiring between buildings because the unit will assume different ground potentials.
- Do not run power in the same conduit or wire bundle with communication link wiring.

**Note:** You do not need to observe polarity for LonTalk communication links.

### Recommended Wiring Practices

The following guidelines should be followed while installing communication wire.

- LonTalk is not polarity sensitive. Trane recommends that the installer keep polarity consistent throughout the site.
- Only strip away two inches maximum of the outer conductor of shielded cable.
- Make sure that the 24 Vac power supplies are consistent in how they are grounded. Avoid sharing 24 Vac between LonTalk UCMs.
- Avoid over-tightening cable ties and other forms of cable wraps. A tight tie or wrap could damage the wires inside the cable.
- Do not run LonTalk cable alongside or in the same conduit as 24 Vac power.
- In an open plenum, avoid lighting ballasts, especially those using 277 Vac.
- Do not use a trunk and branch configuration, if possible. Trunk and branch configurations shorten the distance cable can be run.

### Device Addressing

LonTalk devices are given a unique address by the manufacturer. This address is called a Neuron ID. Each Tracer<sup>®</sup> ZN510 and ZN520 controller can be identified by its unique Neuron ID, which is printed on a label on the controller's logic board. The Neuron ID is also displayed when communication is established using Tracer<sup>®</sup> Summit or Rover service tool. The Neuron ID format is 00-01-64-1C-2B-00.

### Tracer<sup>®</sup> UC400-B Controller

The Tracer<sup>®</sup> UC400-B single-zone VAV controller can be used in a stand-alone application or as part of a Tracer<sup>®</sup> control system.

In the stand-alone configuration, Tracer<sup>®</sup> UC400-B receives operation commands from the zone sensor and/or the auto changeover sensor (on auto changeover units). The entering water temperature is read from the

auto changeover sensor and determines if the unit is capable of cooling or heating. The zone sensor module is capable of transmitting the following information to the controller:

- Timed override on/cancel request
- Zone setpoint
- Current zone temperature
- Fan mode selection (off-auto-high-med-low)

For optimal system performance, units can operate as part of a Tracer<sup>®</sup> SC building automation system. The controller is linked directly to the Tracer<sup>®</sup> SC via a twisted pair communication wire, requiring no additional interface device (i.e., a command unit). The Tracer<sup>®</sup> control system can monitor or override Tracer<sup>®</sup> UC400-B control points. This includes such points as temperature and output positions.

**Note:** For more detailed information, refer to:

- BAS-SVX20C-EN Tracer<sup>®</sup> UC400-B Programmable Controller Installation, Operation, and Maintenance manual

### Communication Wire Specifications

All wiring must comply with the National Electrical Code (NEC<sup>™</sup>) and local electrical codes.

Field-supplied BACnet MS/TP link wiring must be installed in compliance with NEC and local codes. The wire must be low-capacitance, 18-gauge, stranded, tinned-copper, shielded, twisted-pair.

**Note:** For more details, refer to Wiring Guide: Unit Controller Wiring for the Tracer<sup>®</sup> SC System Controller (BAS-SVN03D-EN, or the most recent revision).

### General Wiring Guidelines

Figure 44. Connecting wires to terminal



To connect wires to the UC400-B controller or the expansion modules:

1. Strip the wires to expose 0.28 inch (7 mm) of bare wire.
2. Insert the wire into a terminal connector.

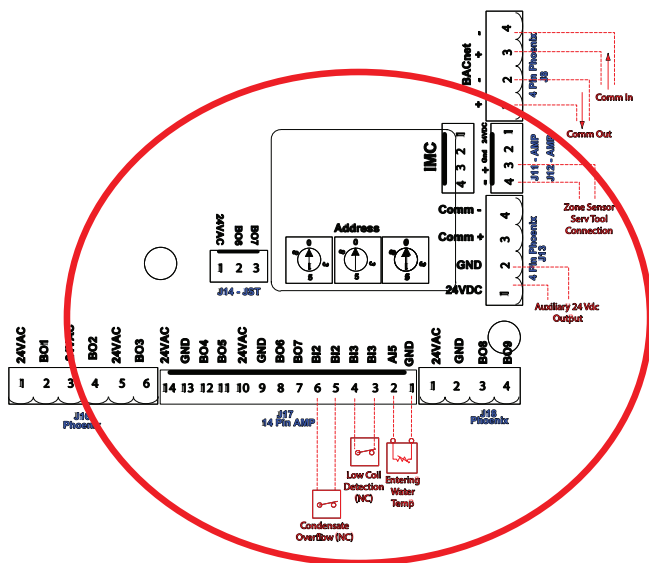
3. Tighten the terminal screw to 0.5 to 0.6 N-m (71 to 85 ozf-in or 4.4 to 5.3 lbf-in.).
4. Tug on the wires after tightening the screws to ensure all wires are secure as shown on the right.

### Setting the Address

The rotary address dials on the UC400-B controller serve one or two purposes depending upon the network: they are always used for the MAC Address, which is sometimes all or part of the BACnet Device ID as shown in the following figure.

Use a 1/8 inch (3.2 mm) flathead screwdriver to set rotary address dials. Dials rotate in either direction.

**Figure 45. Setting rotary address dials**



### MAC Address

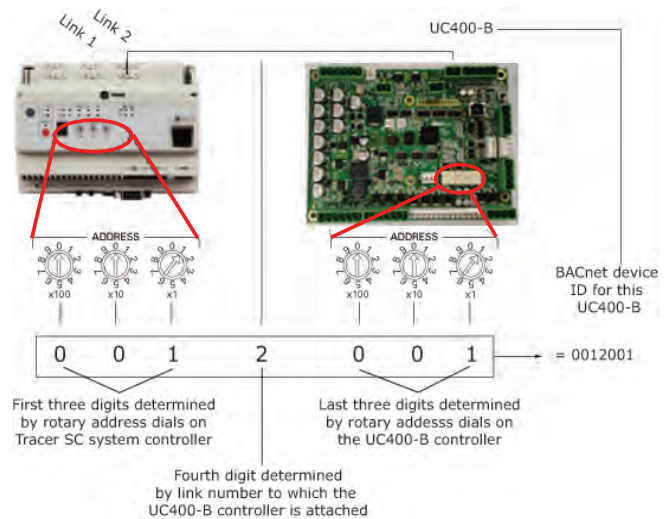
The MAC Address is required by the RS-485 communication protocol on which BACnet operates. A UC400-B controller can use a MAC Address from 001 to 120.

**Important:** Each device on the link must have a unique MAC Address/Device ID. The controller rotary addresses should be sequentially set, with no gaps in the numbering, starting with 001 on each link (for example 001, 002, 003, 004 and so on). A duplicate address or a 000 address setting will interrupt communications and cause the Tracer® SC device installation process to fail.

### BACnet Device ID

The BACnet Device ID is required by the BACnet network. Each device must have a unique number from 001 to 4094302. See the following figure.

**Figure 46. BACnet device ID**



### BACnet networks without a Tracer® SC system controller

On BACnet networks without a Tracer® SC system controller, the Device ID can be assigned one of two ways:

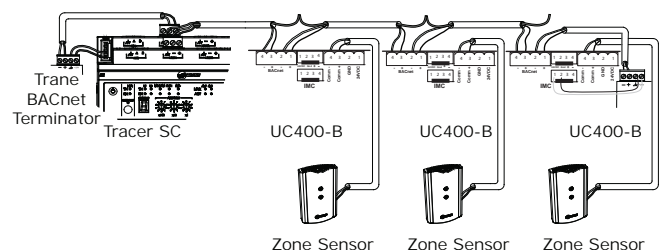
- It can be the same number as the MAC Address, determined by the rotary address dials on the UC400-B controller. For example, if the rotary address dials are set to 042, both the MAC Address and the BACnet Device ID are 042.
- It can be soft set using the Tracer® TU service tool. If the BACnet Device ID is set using the Tracer® TU service tool, the rotary address dials *only* affect the MAC Address, they do not affect the BACnet Device ID.

### BACnet networks with a Tracer® SC system controller

On BACnet networks with a Tracer® SC system controller, the Device ID for the UC400-B controller is always soft set by the system controller using the following scheme illustrated below.

**Note:** The BACnet Device ID is displayed as the Software Device ID on the Tracer® TU **Controller Settings** page in the **Protocol** group.

**Figure 47. Example of BACnet link wiring with multiple UC400-B controllers**



## Power Supply

Please read all of the warnings, cautions, and notices below before proceeding with this section.

### ⚠ WARNING

#### Hazardous Voltage!

Failure to disconnect power before servicing could result in death or serious injury. Disconnect all electric power, including remote disconnects before servicing. Follow proper lockout/tagout procedures to ensure the power can not be inadvertently energized. Verify that no power is present with a voltmeter.

### ⚠ CAUTION

#### Personal Injury and Equipment Damage!

After installation, make sure to check that the 24 Vac transformer is grounded through the controller. Failure to check could result in personal injury and/or damage to equipment. Measure the voltage between chassis ground and any ground terminal on the UC400-B controller. Expected result: Vac  $\leq$  4.0 V

### NOTICE:

#### Avoid Equipment Damage!

Sharing 24 Vac power between controllers could cause equipment damage.

A separate transformer is recommended for each UC400-B controller. The line input to the transformer must be equipped with a circuit breaker sized to handle the maximum transformer line current.

If a single transformer is shared by multiple UC400-B controllers:

- The transformer must have sufficient capacity.
- Polarity must be maintained for every UC400-B controller powered by the transformer.

**Important:** If the polarity is inadvertently reversed between two controllers powered by the same transformer, a difference of 24 Vac will occur between the grounds of each controller, which can result in:

- Partial or full loss of communication on the entire BACnet MS/TP link
- Improper function of the UC400-B controller outputs
- Damage to the transformer or a blown transformer fuse

## Transformer Recommendations

A 24 Vac power supply must be used for proper operation of the binary inputs, which requires 24 Vac detection. In addition, the spare 24 Vac outputs may be used to power relays and TRIACS.

- AC transformer requirements: *UL listed, Class 2 power transformer, 24 Vac  $\pm$  15%, device max load 24VA. The transformer must be sized to provide adequate power to the controller (12VA) and outputs (maximum 12VA per binary output).*
- CE-compliant installations: *The transformer must be CE marked and SELV compliant per IEC standards.*

## Wiring Requirements

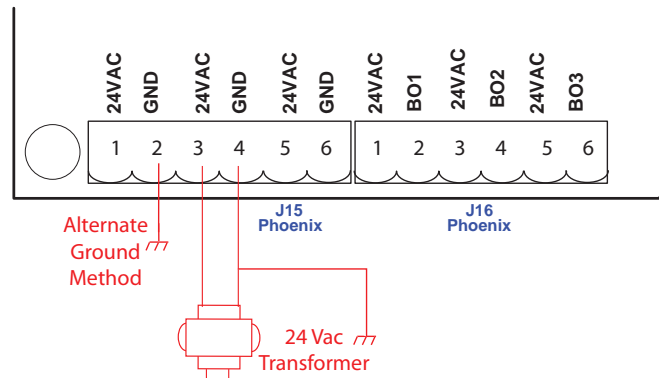
To ensure proper operation of the UC400-B controller, install the power supply circuit in accordance with the following guidelines:

- A dedicated power circuit disconnect switch must be near the controller, easily accessible by the operator, and marked as the *disconnecting device* for the controller.
- 18 AWG (0.823 mm<sup>2</sup>) copper wire is recommended for the circuit between the transformer and the controller.

**Important:** The controller must receive AC power from a dedicated power circuit; failure to comply may cause the controller to malfunction. DO NOT run AC power wires in the same wire bundle with input/output wires; failure to comply may cause the controller to malfunction due to electrical noise.

## Connecting Wires

Figure 48. Grounding the controller



To connect the wires:

1. Disconnect power to the transformer.
2. Connect the 24 Vac secondary wires from the transformer to the 24 Vac and  $\llcorner$  terminals on the UC400-B controller (refer to the illustration below).
3. Do one of the following to ensure the controller is adequately grounded:
  - Connect a grounding pigtail at some point along the secondary wire that runs between the controller  $\llcorner$  terminal and the transformer.
  - Ground one of the  $\llcorner$  terminals on the controller to the enclosure (if the enclosure is adequately grounded) or to an alternate earth ground.

**Note:** A pigtail connection may be necessary between earth ground and/or enclosure ground if the device is not grounded through one leg of the transformer wiring.

### Power ON Check

To perform a **Power ON** check:

1. Verify that the 24 Vac connector and the chassis ground are properly wired.
2. Remove the lockout/tagout from the line voltage power to the electrical cabinet.
3. Energize the transformer to apply power to the UC400-B controller.
4. Observe the UC400-B controller when power is applied to verify the power check sequence as follows:
  - a. The power LED lights red for 1 second
  - b. The power LED lights green
    - If the sequence above is completed as described, the controller is properly booted and ready for the application code.

If the power LED flashes red, a fault condition exists.

## Air-Fi® Wireless Communications Systems

For more detailed information on Air-Fi® Wireless Communications systems and devices, see:

- BAS-SVX40: *Air-Fi® Wireless Installation, Operation, and Maintenance*
- BAS-PRD021: *Air-Fi® Wireless Product Data Sheet*
- BAS-SVX55: *Air-Fi® Wireless Network Design*

### Air-Fi® Wireless Communications Interface (WCI)



A factory-installed Air-Fi® Wireless Communications Interface (WCI) provides wireless communication between the Tracer® SC and Tracer® unit controllers. The Air-Fi® WCI is the perfect alternative to a Trane BACnet® wired communication link. Eliminating the communication wire between terminal products, space sensors, and system controllers has substantial benefits:

- Reduced installation time and associated risks.

- Completion of projects with fewer disruptions.
- Easier and more cost-effective re-configurations, expansions, and upgrades

### Air-Fi® Wireless Communications Sensor (WCS)



Communicates wirelessly to a Tracer® unit controller. A WCS is an alternative to a wired sensor when access and routing of communication cable are issues. A WCS allows flexible mounting and relocation.

### Wireless Zone Sensor (WZS) Set



A wireless zone sensor (WZS) set (sensor and receiver) communicates wirelessly to a Tracer® unit controller. A wireless zone sensor set is an alternative to a wired sensor when access and routing of communication cable are issues. The sensor allows flexible mounting and relocation.

**Note:** A wireless zone sensor set is not compatible with an Air-Fi® wireless system.

The Wireless Comm Interface (WCI) enables wireless communication between system controls, unit controls, and wireless sensors for the new generation of Trane control products. The WCI replaces the need for communication wire in all system applications.

**Note:** For more detailed information, refer to:

- BAS-SVX40A-EN - Wireless Comm Installation, Operation and Maintenance manual
- BAS-SVX55A-EN - Wireless Comm Network Design Best Practices Guide



## Installation - Controls

---

### Quantity of WCIs per Network

Each Trane wireless network can have a total of 31 WCIs (30 member WCIs plus one coordinator WCI). Each network requires one WCI to function as network coordinator.

### Quantity of Networks per Tracer<sup>®</sup> SC

A Tracer<sup>®</sup> SC can support up to eight wireless networks.

### Automatic Network Formation

When a WCI is connected to a Tracer<sup>®</sup> SC, it is auto-assigned as the coordinator. To enable the coordinator, Tracer<sup>®</sup> SC must be configured for wireless communication. The coordinator WCI opens the network to allow all WCIs having matching addresses to automatically join the network. If no Tracer<sup>®</sup> SC is present, a centrally located WCI must be designated to act as the coordinator. You can manually set the coordinator WCI so all WCIs having matching addresses automatically join the network.

### Wireless Zone Sensors

The WCI also communicates with Trane wireless zone sensors, eliminating the need for analog receivers.

### Wired Zone Sensors

Systems using WCI can also use wired zone sensors.

### Specifications

Operating Temperature: -40 to 158°F (-40 to 70°C)

Storage temperature: -40 to 185°F (-40 to 85°C)

Storage and operating humidity range: 5 percent to 95 percent relative humidity (RH), non-condensing

Voltage: 24 Vac/VDC nominal  $\pm$  10 percent. If using 24 Vac, polarity must be maintained.

Receiver power consumption: <2.5 VA

Housing material: Polycarbonate/ABS (suitable for plenum mounting), UV protected, UL 94: 5VA flammability rating

Mounting: Snaps into sheet metal opening.

Range: Open range: 2,500 ft (762 m) with packet error rate of 2 percent.

Indoor: Typical range is 200 ft (61 m); actual range is dependent on the environment. See BAS-SVX55-EN for more detail.

**Note:** Range values are estimated transmission distances for satisfactory operation. Actual distance is job specific and must be determined during site evaluation. Placement of WCI is critical to proper system operation. In most general office space installations, distance is not the limiting factor for proper signal quality. Signal quality is affected by walls, barriers, and general clutter. For more information os available at [www.trane.com](http://www.trane.com).

Output power: North America: 100 mW

Radio frequency: 2.4 GHz (IEEE Std 802.15.4-2003 compliant) (2405–2480 MHz, 5 MHz spacing)

Radio channels: 16

Address range: Group 0–8, Network 1–9

### Mounting

Fits a standard 2 in. by 4 in. junction box (vertical mount only). Mounting holes are spaced 3.2 in. (83 mm) apart on vertical center line. Includes mounting screws for junction box or wall anchors for sheet-rock walls. Overall dimensions: 2.9 in. (74 mm) by 4.7 in. (119 mm)

### Wireless protocol

ZigBee PRO—ZigBee Building Automation Profile, ANSI/ASHRAE Standard 135-2008 Addendum q (BACnet™ / ZigBee)

## Zone Sensor Options

A variety of wall-mounted zone sensors are available for design flexibility. Zone sensors have an internal

thermistor and operate on 24 Vac. Options with setpoint knobs are available in Fahrenheit or Celsius.

<p><b>Figure 49. Wall-mounted zone sensor with setpoint dial, OA, occupied/unoccupied, COMM</b></p>	<p><b>Figure 50. Wall mounted zone sensor with setpoint dial, occupied/unoccupied, COMM.</b></p>	<p><b>Figure 51. Wall-mounted zone sensor with occupied/unoccupied, COMM.</b></p>
<p><b>Figure 52. Wireless zone sensor, unit mounted receiver.</b></p>	<p><b>Figure 53. Wall-mounted zone sensor with setpoint dial, OALMH, occupied/unoccupied, COMM.</b></p>	<p><b>Figure 54. Wall-mounted wired display sensor (WDS) with setpoint adjustment, OALMH.</b></p>
<p><b>Figure 55. Wireless display sensor (WDS) with setpoint, OALMH, and unit-mounted receiver</b></p>	<p><b>Figure 56. Air-Fi® Wireless Communications Sensor (WCS) with setpoint, OALMH (UC400-B only)</b></p>	<p><b>Figure 57. Wall-mounted fan speed switch</b></p>

## Zone Sensor Installation

### Location Considerations

When selecting a location for the zone sensor, avoid the following:

- Dead spots, such as behind doors, projection screens, or in corners that do not allow free air circulation.
- Air drafts from stairwells, outside doors, or unsectioned hollow walls.
- Airflow from adjacent zones or other units.
- Unheated or uncooled spaces behind the controller, such as outside walls or unoccupied spaces.
- Concealed pipes, air ducts, or chimneys in partition spaces behind the controller.
- Areas in the direct airstream of air diffusers
- Exterior walls and other walls that have a temperature differential between the two sides
- Areas that are close to heat sources such as sunlight, appliances, concealed pipes, chimneys, or other heat-generating equipment
- Walls that are subject to high vibration
- Areas with high humidity
- High traffic areas (to reduce accidental damage or tampering)
- Metal barriers between the receiver and the sensor (for example, plastered walls with metal lathe or metal roof decks)
- Thick, solid concrete walls between the receiver and the sensor

### Location Considerations for Wireless Zone Sensors

Placement of the sensor is critical to proper operation (the receiver is factory mounted). For most installations, barriers limit proper radio signal strength more than distance. For best radio transmission range and reliability, mount the receiver and sensor in line of sight. Where this is not possible, try to minimize the number of barriers between the pair of devices. In general, sheetrock walls and ceiling tiles offer little restriction to the transmission range for the sensor is as follows:

- Open range: 2,500 ft (packet error rate = 2%)
- Usable range: 200 ft
- Typical range: 75 ft

### Height Requirements

It is recommended that you mount the back plate a maximum distance of 54 inches above the floor. If a parallel approach by a person in a wheelchair is required, reduce the maximum height to 48 inches.

**Note:** Consult section 4.27.3 of the 2002 ADA (Americans with Disability Act) guideline, and local building

codes, for further details regarding wheelchair requirements.

### Mounting Surfaces

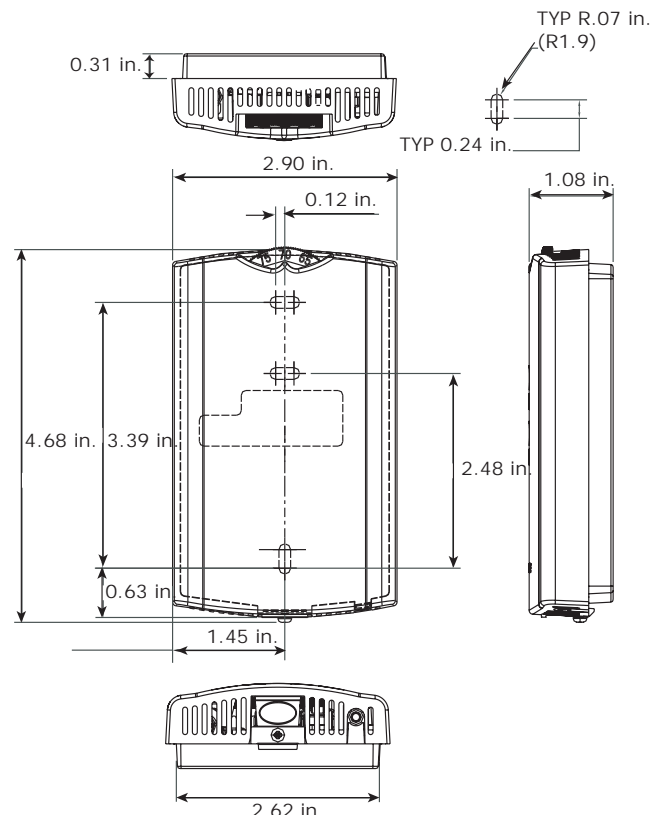
Using the hardware provided, mount the back plate of the sensor to a flat surface such as sheetrock or plaster, or an electrical junction box. The sensor must be mounted plumb for accurate temperature control and to ensure proper air movement through the sensor.

- If mounting onto sheetrock or plaster, use the plastic threaded anchors (pre-drilling holes is not usually necessary) and the two M3.5 x 20 mm mounting screws.
- For mounting onto an electrical junction box, use the two 6-32 x 3/4 in. screws.

### Zone Sensor Dimensions

Refer the wall-mounted zone sensor dimensions in the following figure. Position the sensor on an inside wall three to five feet above the floor and at least 18 inches from the nearest outside wall. Installing the sensor at a lower height may give the advantage of monitoring the temperature closer to the zone, but it also exposes the sensor to airflow obstructions. Ensure that air flows freely over the sensor.

**Figure 58. Wall-mounted wired and wireless zone sensor dimensions**

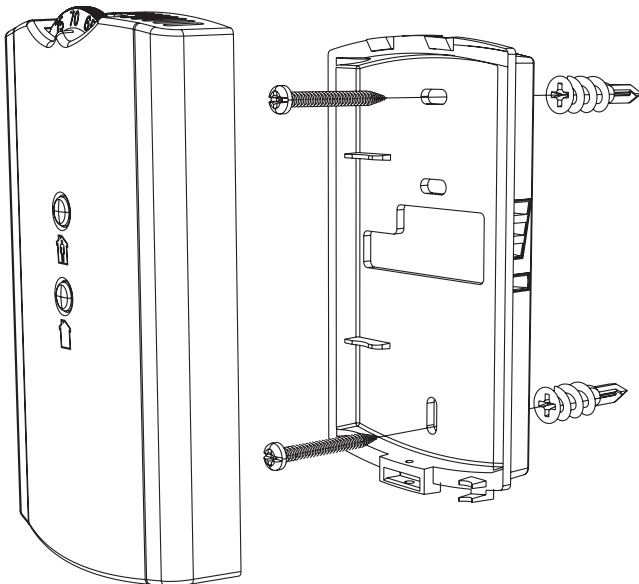


## Wired Zone Sensor

Refer to the unit wiring schematic for specific wiring details and point connections.

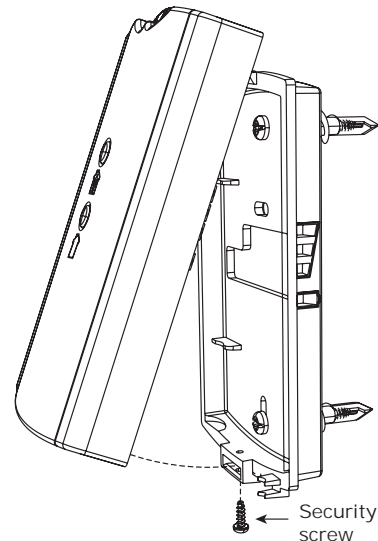
1. Note the position of the setpoint adjustment knob and gently pry the adjustment knob from the cover using the blade of a small screwdriver.
2. Insert the screwdriver blade behind the cover at the top of the module and carefully pry the cover away from the base.
3. To mount the sensor back plate: (see the following figure).
  - a. Hold the back plate against the mounting surface and mark the screw locations.
  - b. Secure the back plate against the mounting surface using included hardware.

**Figure 59. Mounting zone sensor base plate**



4. To install the zone sensor module to a standard junction box:
  - a. Level and install a 2 x 4-in. junction box (installer supplied) vertically on the wall.
  - b. Pull the control wires through the cutout. Attach the module to the wall using the screws provided.
5. Strip the insulation on the interconnection wires back 0.25-inch and connect to TB1 (for wired sensors).
6. Screw down the terminal blocks (for wired sensors).
7. To replace the cover:
  - a. Hook the cover over the top of the back plate. Apply light pressure to the bottom of the cover until it snaps in place.
  - b. Install the security screw into the bottom of the cover if desired (see [Figure 60](#)).

**Figure 60. Mounting zone sensor security screw**



## Wireless Zone Sensors

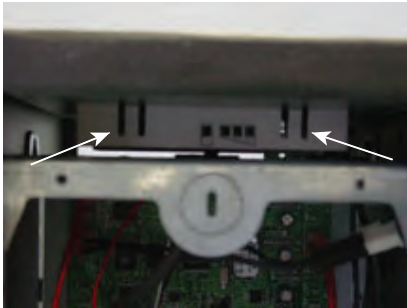
1. Note the position of the setpoint adjustment knob and gently pry the adjustment knob from the cover using the blade of a small screwdriver.
2. Insert the screwdriver blade behind the cover at the top of the module and carefully pry the cover away from the base.
3. To mount the sensor back plate: (see [Figure 59](#))
  - a. Hold the back plate against the mounting surface and mark the screw locations.
  - b. Secure the back plate against the mounting surface using included hardware.
4. To replace the cover:
  - a. Hook the cover over the top of the back plate. Apply light pressure to the bottom of the cover until it snaps in place.
  - b. Install the security screw into the bottom of the cover if desired (see [Figure 60](#)).

**Note:** For more detailed information for wireless sensors, please see [BAS-SVX40](#).

## Receivers

Receivers ship installed on the unit. To remove the receiver, press in the retention tabs on the underside of the receiver enclosure (see [Figure 61](#)) and push upward.

**Figure 61. Retention tabs on underside of receiver enclosure**



## Zone Sensor Settings

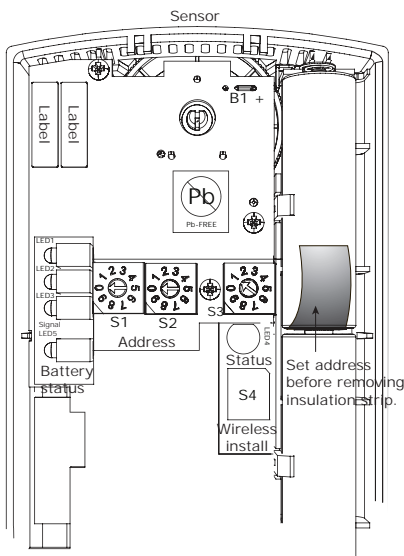
### Address Setting

The process of establishing communication between a receiver and sensor is referred to as *association*. The following limitations apply:

- Each associated receiver/sensor set that communicates within the reception range of the wireless system must have a unique address.
- It is not possible to associate more than one sensor to a receiver, nor is it possible to associate more than one receiver to a sensor.
- To associate a receiver and sensor, the two devices must have their rotary address switches set to the same address.

**Important:** Set the addresses before applying power to the receiver and before removing the insulation strip (Figure 62) from the sensor.

**Figure 62. Set address before removing insulation strip from the sensor.**

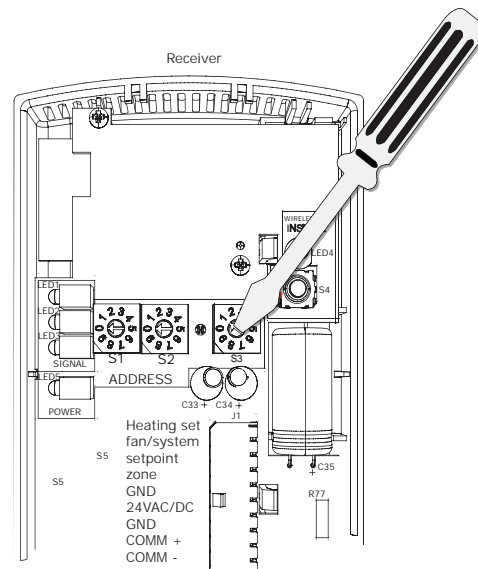


To set the receiver and sensor addresses:

1. Using a small screwdriver, set the three rotary address switches (locations S1, S2, S3) on the receiver to an address between 001 and 999 (see the following figure). You do not have to remove the covers to access the rotary address switches.

**Note:** Do not use 000 as an address. An address of 000 returns the receiver outputs to their factory defaults (zone temperature and setpoint outputs: 72.5°F, removes all association knowledge, and prevents association with a sensor).

**Figure 63. Set the rotary address switches on the receiver**



2. Set the three rotary address switches (locations S1, S2, S3) on the sensor to the same address as the receiver (see Figure 63).

**Note:** Do not use 000 as an address. An address of 000 removes all association knowledge, reverts the sensor to a low-power hibernation mode, and sends a disassociation request to the receiver.

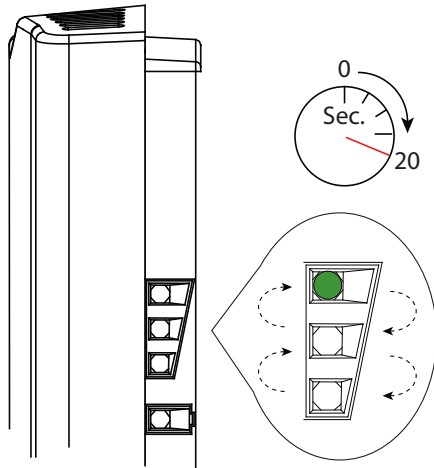
3. Record the address and location of the receiver and sensor pair.

### Observing Receiver for Readiness

After initial power up, the receiver conducts a channel scan for 20 seconds. See Figure 64). During this time, the receiver selects from 16 available channels the clearest channel on which to operate. LED1, LED2, and LED3 flash rapidly in succession (round-robin style) while the channel scan is in progress.

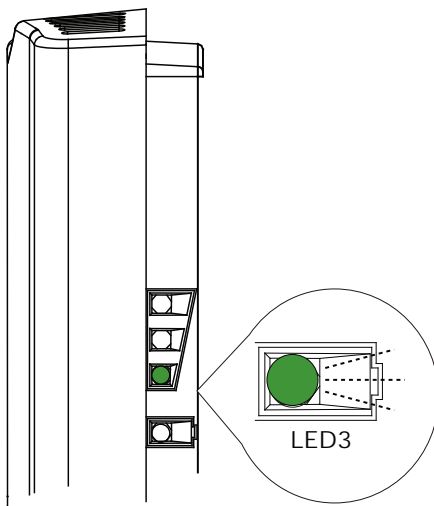
**Important:** Do not attempt association (leave the insulation strip in place) until the channel scan is finished.

**Figure 64. Receiver conducts 20 second channel scan**



After the channel scan is finished, LED3 begins blinking (one-blink pattern) to show that the receiver is ready to be associated with a sensor. (See [Figure 65](#))

**Figure 65. LED3 blinks after channel scan to show receiver is ready**

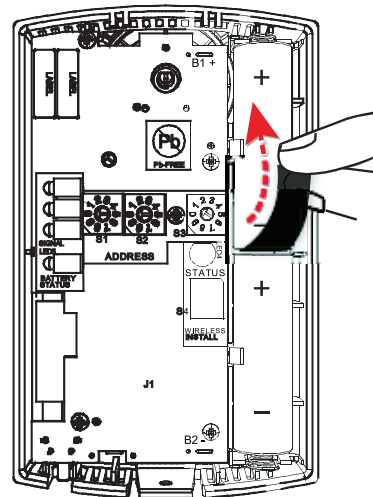


## Associating Sensor to Receiver

To associate the sensor to the receiver:

1. Remove the sensor cover by firmly pressing the thumb tab at the bottom of the cover and pulling the cover away from the back plate.
2. Verify that the sensor is set to the same address as the receiver it is to be associated with.
3. Power the sensor by removing the insulation strip from between the two batteries. See [Figure 66](#).

**Figure 66. Power sensor by removing insulation strip**



Association is automatically initiated between the sensor and the receiver. When LED3 on the receiver stops blinking, association has been established.

If the first association attempt is unsuccessful, the sensor automatically re-attempts association with the receiver every 10 minutes.

**Note:** An associated sensor that has lost communication with the receiver will transmit an association request every 50 minutes. You can manually initiate association (see ["Manual Association," p. 113](#)).

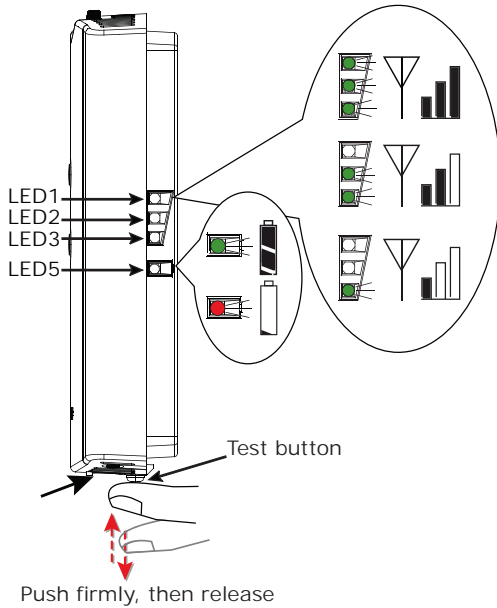
## Testing Signal Strength and Battery

To verify that the association process was successful and that the batteries have adequate charge:

1. Firmly press and release the Test button on the bottom of the sensor as illustrated in [Figure 67](#).
2. For model WZS, view LED1, LED2, and LED3 to determine the signal strength. View LED5 to determine the battery status (see [Figure 67](#) for model WZS sensors).

**Note:** The LEDs will turn Off after 5 seconds to conserve battery strength.

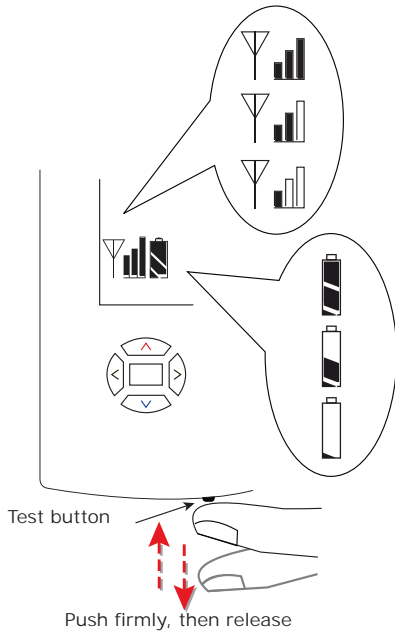
Figure 67. Wireless Zone Sensor (WZS) with LED lights to test for battery strength



For model WDS, determine the signal strength and battery status by viewing the symbols on the sensor display (see Figure 68 for model WDS sensors).

- Record the results in your commissioning statement.

Figure 68. Wireless Display Sensor (WDS) showing battery strength



## Sensor Operations

### Temporary Occupancy (Timed Override)

Temporary occupancy (timed override) is available on model WDS. Temporary occupancy is selected for after-business-hours adjustment of temperature setting, fan settings, or heat/cool settings, when the system has changed to unoccupied mode. System control will revert to unoccupied after a pre-determined time period.

**Note:** Not all systems support the occupancy function.

To request and cancel temporary occupancy on a model WDS sensor, see “Requesting Temporary Occupancy,” p. 61.

### End-of-Range Temperature Values

**Receiver:** The end-of-range temperature limits of the receiver for all models are 32°F to 122°F. The receiver cannot replicate temperature values outside this range. If the sensor transmits a temperature value to the receiver that is out of the receiver replication range, the receiver will “freeze” the output at the end-of-range values. This value will remain frozen until the transmitted temperature moves to between the end-of-range temperature limits.

**Sensor:** The end-of-range temperature setpoint limits for the WDS is 50°F to 89.6°F.

### Receiver Power-up Sequence

When power is applied to the receiver, one of the following sequences occurs. The sequence is dependent on the address setting and the association status of the receiver.

#### Address set to 000 and receiver is not associated with a sensor

- LED5 is constantly On, indicating power is applied and the receiver is functional.
- All models: Zone temperature and cooling setpoint default to 72.5°F.  
WDS only: The heating setpoint defaults to 70.5°F and the fan/system output will be 2230 Ω (see “Failure and Default Modes,” p. 114).
- Status LED3 will display a 2-blink pattern diagnostic (Table 55, p. 112).

#### Address set from 001 to 999 and receiver is not associated with a sensor

- LED5 is constantly On, indicating power is applied and the receiver is functional.
- All models: Zone temperature and cooling setpoint default to 72.5°F.  
WDS only: The heating setpoint defaults to 70.5°F and the fan/system output will be 2230 Ω (see “Failure and Default Modes,” p. 114).
- The receiver conducts an energy scan for 20 seconds to determine the clearest channel on which to operate.

- LED3 flashes On every 2 seconds when it is ready to accept a sensor association request. When an association request is made by a sensor, the receiver instructs the sensor on which power level to operate. Then the receiver and sensor begin operation at the appropriate channel and power level (see “[Observing Receiver for Readiness,](#)” page 54).

**Address set from 001 to 999 (and not changed since most recent power-up) and receiver is associated with a sensor**

- LED5 is constantly On, indicating power is applied and the receiver is functional.
- Zone temperature and setpoint default to 72.5°F. WDS only: Heating setpoint defaults to 70.5°F, Fan = Auto, System = Off.
- The receiver waits for a broadcast transmission from its associated sensor. When a transmission is received, the receiver positions its zone temperature and setpoint outputs appropriately.
- If the receiver does not receive a communicated signal from its associated sensor within 35 minutes, zone temperature and setpoint outputs fail, generating a unit controller alarm (see “[Failure and Default Modes,](#)” p. 114).

**Note:** Once a receiver communicates to a WZS sensor, the receiver disables (opens) its zone setpoint output indefinitely.

**Transmission Variables**

Sensor transmission time variables are as follows:

- The maximum time between sensor temperature transmissions is 15 minutes.
- The minimum time between sensor temperature transmissions is 30 seconds.
- The minimum time for transmitting temperature setpoint changes is 10 seconds.

**Note:** If a sensor transmits a message to the receiver and the receiver does not reply, the sensor will retransmit the message to the receiver every 30 seconds until communication to the receiver is re-established.

Sensor temperature time variables are as follows:

- The minimum change in zone temperature required to force a sensor transmission is:
  - 0.2°F when the temperature range is between 60°F and 80°F
  - 0.5°F when the temperature range is between 32°F and 60°F or between 80°F and 122°F
- The minimum change in temperature setpoint required to force a sensor transmission is: 0.1°C for a model WDS sensor

**Wireless Sensor Specifications**

**Table 20. Wireless sensor specifications**

Component	Type
Sensor operating temperature	32°F to 122°F
Receiver operating temperature	-40°F to 158°F
Storage temperature	-40°F to 185°F
Storage and operating humidity range	5% to 95%, non-condensing
Accuracy	0.5°F over a range of 55°F to 85°F
Resolution	0.125°F over a range of 60°F to 80°F 0.25°F when outside this range
Setpoint functional range (WDS only)	50°F to 89.6°F
Receiver voltage	24 V nominal ac/dc ±10%
Receiver power consumption	<1 VA
Housing	Polycarbonate/ABS blend, UV protected, UL 94-5VA flammability rating, suitable for application in a plenum
Mounting	3.24 in (8.26 cm) for 2 mounting screws (supplied)
Sensor battery	(2) AA, 1.5 V, 2800 mAh, lithium, 5-year life, UL listed
Range <sup>1</sup>	Open range: 2,500 ft (762 m) (packet error rate = 2 percent) Usable: 200 ft (61 m) Typical: 75 ft (23 m)
Output power	100 mW
Radio frequency	2.4 GHz (IEEE Std 802.15.4-2003 compliant) (2405 to 2480 MHz, 5 MHz spacing)
Radio channels	16
Address range	000 to 999
Minimum time between transmissions	30 seconds
Maximum time between transmissions	15 minutes

**Note:** <sup>1</sup>Range values are estimated transmission distances for satisfactory operation. Actual distance is job specific and must be determined during site evaluation.

## Agency Compliance

The European Union (EU) Declaration of Conformity is available from your local Trane® office.

## Wireless Display Sensor (WDS)

### Configuration Procedure

**Note:** Sensors shipped with the fan coil are pre-configured for three speeds.

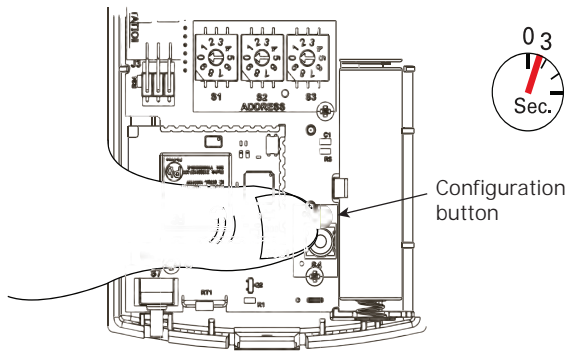
The configuration of the sensor determines which system features can be accessed and changes can be made by the tenant (for example, changes to cooling/heating mode, setpoint, or fan speed). Verify system and associated unit features before configuring the sensor.

The building owner or operator may choose to limit tenant access to certain features. This can be done through configuration. Or, if a sensor is configured to match all control capabilities of the building automation system, the locking feature can be used to restrict the tenant from making changes.

To configure settings on the wireless display sensor (WDS), follow this procedure in the order presented.

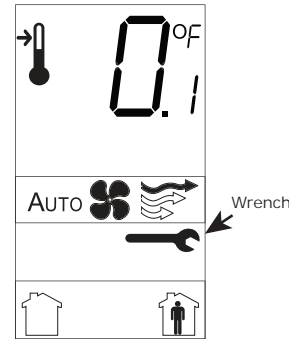
1. Press the configuration button for three seconds.

**Figure 69. Configuration button**



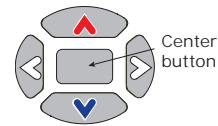
The display will change to configuration mode. When the sensor is in configuration mode, a wrench symbol appears on the display and the menus are separated by lines, as shown in [Figure 70](#).

**Figure 70. Wrench is shown in configuration mode**



2. Press the center button on the keypad to begin the configuration process.

**Figure 71. Center button of keypad**



3. Configure the sensor options in the order shown in the table.
  - Press or to scroll to the next selection (as illustrated).
  - Press or to move to the next menu (as illustrated in [Table 21](#)).
4. Review the display to ensure that you have selected the correct configuration.
5. To return the display to operating mode, press the configuration button (see [Step 1](#)).

**Note:** The sensor will revert to operating mode if no buttons are pressed for 10 minutes.

**Table 21. Configuration options for wireless display sensors**

Setting	Configuration Options					
<b>Temperature</b> • Choose Fahrenheit or Celsius • Choose the degree resolution (whole degrees, half degrees, or tenths of degrees).						
<b>Setpoint</b>						
	No setpoint	Single setpoint				

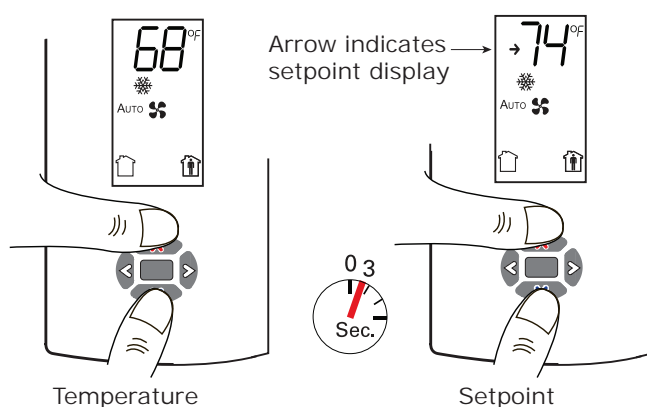
**Table 21. Configuration options for wireless display sensors**

Setting	Configuration Options
<b>System</b>	<p>No system options enabled</p>
<b>Fan</b>	<p><b>Note:</b> Not all fan options are available for all systems.</p> <p>Auto/Off      Auto/Off/Low/High      Auto/Off/Low/Med/High</p> <p>Off/High (On)      Off/Low/High      Off/Low/Med/High      No fan options enabled</p>
<b>Occupancy (timed override)</b>	<p>Occupancy enabled      Occupancy disabled</p>

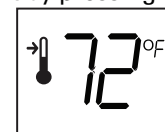
### Displaying Setpoint or Temperature

You can configure the sensor to display either the temperature (default) or setpoint. To select either option:

1. Verify that the sensor is in operating mode and at the home screen.
2. Press the up and down arrows for 3 seconds. The arrow indicates setpoint display, as shown in [Figure 72](#).

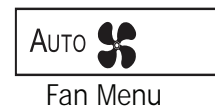
**Figure 72. Displaying setpoint or temperature**


1. Verify that the sensor is in operating mode and at the home screen.
2. Choose a setting to lock or unlock:
  - Select the setpoint by pressing the up or down arrow.



Setpoint

- From the system menu press the down arrow to select the fan menu. Use the left or right arrow to choose the setting.



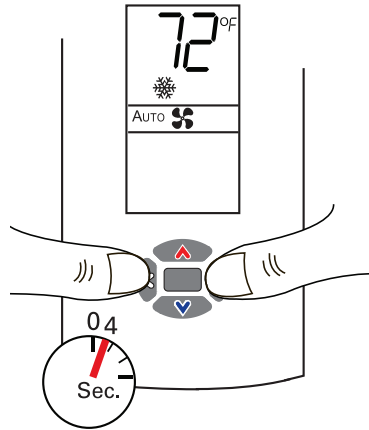
Fan Menu

3. Press the left and right arrows for 4 seconds.

### Locking or Unlocking Settings

You can lock or unlock the setpoint, system, or fan setting to prevent changes. To lock or unlock a setting:

**Figure 73. Locking and unlocking settings**

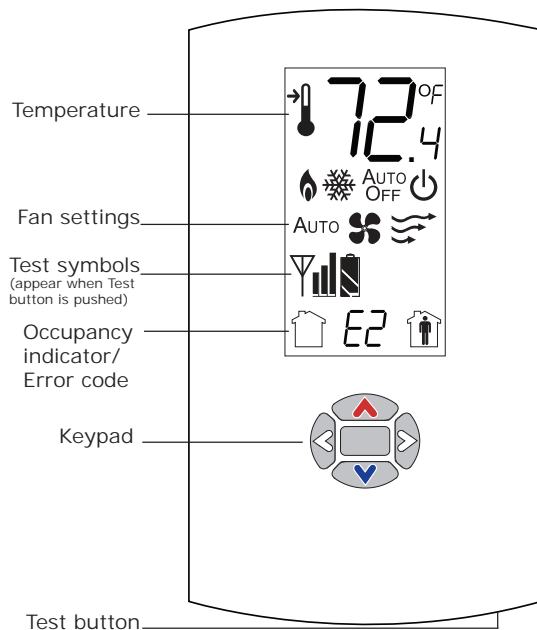


**Note:** If you try to access a feature that is locked, the locked symbol will appear on the display. If you press a keypad button to try change a locked setting, the locked symbol will flash.

## WDS Operating Mode

This section describes how to operate the wireless display sensor (WDS). [Figure 74](#) shows an example of a WDS that has been configured and is in operating mode.

**Figure 74. Wireless display sensor (model WDS) in operating mode**



## Changing Room Temperature

	<p>This symbol shows the current room temperature, or your setpoint selection while you are making an adjustment.</p>	<ol style="list-style-type: none"> <li>To increase the room temperature, press .</li> <li>To decrease the room temperature, press .</li> </ol>
	<p>When you select a setpoint, this symbol appears.</p>	<ol style="list-style-type: none"> <li>To confirm, press  or wait 5 seconds. The display will return to the home screen.</li> </ol>

## Changing Heating/Cooling Settings

(does not apply to all systems)

	<p>Some systems allow you to select both heating and cooling room temperature settings. If your system has this option, this symbol appears when you adjust the temperature setting.</p>	<ol style="list-style-type: none"> <li>Press  or  to select the heating/cooling setting.</li> </ol>
	<p>When you adjust the cooling setting, the top arrow and snowflake flash.</p>	<ol style="list-style-type: none"> <li>If in cooling mode, press  to change to heating mode. If in heating mode, press  to change to cooling mode.</li> </ol>
	<p>When you adjust the heating setting, the bottom arrow and flame flash.</p>	<ol style="list-style-type: none"> <li>Press  or  to select the heating/cooling setting.</li> </ol>
		<ol style="list-style-type: none"> <li>To confirm, press  or wait 5 seconds. The home screen will appear.</li> </ol>

## Changing Fan Settings

<p>Fan Menu</p>	<p>Indicates that the fan will operate as needed to reach the selected temperature.</p>	<ol style="list-style-type: none"> <li>From the home screen, activate the fan setting menu by pressing  and then .</li> </ol>
	<p>Indicates that the fan setting is On. The number of arrows indicates fan speed (3: high, 2: medium, 1: low). The example shown indicates a fan on high speed. Not all systems offer all three speeds.</p>	<ol style="list-style-type: none"> <li>Press  or  to choose the desired fan setting.</li> </ol>
	<p>Indicates that the fan setting is Off.</p>	<ol style="list-style-type: none"> <li>When the symbol for the desired setting appears, confirm your choice by pressing  (the home screen will appear).</li> </ol>

## Requesting Temporary Occupancy



Select to request occupancy



Select to cancel occupancy

- If you need heating or cooling after normal business hours, you can “request” temporary occupancy by pressing or and holding it for 2 seconds. The occupied symbol remains on the screen and the unoccupied symbol disappears. After 30 seconds, the unoccupied symbol will re-appear.
- To cancel temporary occupancy, press and hold for 2 seconds. The unoccupied symbol will remain on the screen and the occupied symbol will disappear. After 30 seconds, the occupied symbol will re-appear.

## Error Codes



Indicates an error code

If an error code (E0–E7) is displayed, technical assistance may be required.

## Lock Symbol



Indicates that a setting is locked

The lock symbol appears if you try to adjust a setting that cannot be changed.

## Testing Signal Strength

Indicates excellent signal strength



Indicates satisfactory signal strength



Indicates poor signal strength



Press the Test button to display the signal strength symbols.

## Testing Battery Status

Indicates full battery power



Indicates 50 percent of battery life left.



Indicates 25 percent of battery life left. Replace batteries. Flashing symbol indicates that approximately 14 days of operation remain.



Press the Test button to display the battery status symbols. Use only UL-listed non-rechargeable 1.5 V lithium AA batteries (Trane p/n X13770035010 or equivalent).



# Installation - Electrical

**Note:** Any modifications, additions or changes to the control box could void the factory warranty and UL certification. Such modification, additions or changes will become the responsibly of the modifying contractor.

## Unit Wiring Diagrams

Specific unit wiring diagrams, based on unit options ordered, are provided inside each unit and can be easily removed for reference. Use these diagrams for connections or trouble analysis. Wiring diagrams are attached on the inside of the front panel of vertical cabinet and recessed models and on the fan and motor panel of vertical concealed and all horizontal models.

**Note:** Any modifications, additions or changes to the control box could void the factory warranty and UL certification. Such modification, additions or changes will become the responsibly of the modifying contractor.

## Supply Power Wiring

**⚠ WARNING**

**Hazardous Voltage w/Capacitors!**

Failure to disconnect power and discharge capacitors before servicing could result in death or serious injury. Disconnect all electric power, including remote disconnects and discharge all motor start/run capacitors before servicing. Follow proper lockout/tagout procedures to ensure the power cannot be inadvertently energized. For variable frequency drives or other energy storing components provided by Trane or others, refer to the appropriate manufacturer's literature for allowable waiting periods for discharge of capacitors. Verify with a CAT III or IV voltmeter rated per NFPA 70E that all capacitors have discharged.

For additional information regarding the safe discharge of capacitors, see PROD-SVB06\*-EN.

Refer to the unit nameplate to obtain the minimum circuit ampacity (MCA) and maximum overcurrent protection (MOP) to properly size field supply wiring and fuses or circuit breakers.

Refer to the unit operating voltage listed on the unit wiring schematic, submittal, or nameplate. Reference the wiring schematic for specific wiring connections.

**NOTICE:**

**Use Copper Conductors Only!**

Failure to use copper conductors could result in equipment damage as unit terminals are not designed to accept other types of conductors.

**Note:** All field wiring should conform to NEC and all applicable state and local code requirements. The control panel box is always on the end opposite the piping connections. Access the control box by removing the two screws that secure the front cover. This will allow the panel to be removed, to provide access to the electrical components.

**⚠ WARNING**

**Hazardous Electrical Shorts!**

Failure to do so may cause electrical shorts that could result in death or serious injury. Insulate all power wire from sheet metal ground.

If the unit does not have a disconnect switch, the power leads and capped ground wire are inside the control panel.

If the unit has a disconnect switch, the power leads are wired to the disconnect switch on the control panel.

## Electrical Grounding Restrictions

All sensor and input circuits are normally at or near ground (common) potential. When wiring sensors and other input devices to the Tracer® controller, avoid creating ground loops with grounded conductors external to the unit control circuit. Ground loops can affect the measurement accuracy of the controller.

**NOTICE:**

**Equipment Damage!**

Unit transformer IT1 provides power to fan-coil unit only. Field connections directly to the transformer IT1 may create immediate or premature unit component failure.

All input/output circuits (except isolated relay contacts and optically isolated inputs) assume a grounded source, either a ground wire at the supply transformer to control panel chassis, or an installer supplied ground.

## Interconnection Wiring

The installer must provide interconnection wiring to connect wall-mounted devices such as a fan mode switch or zone sensor module.

Refer to the unit wiring schematic for specific wiring details and point-to-point wiring connections. Dashed lines indicate field wiring on the unit wiring schematics. All interconnection wiring must conform to NEC Class 2 wiring requirements and any state and local requirements.

Refer to the following table for the wire size range and maximum wiring distance for each device.

**Table 22. Maximum wiring distances for low voltage controls (ft)**

Device	Wire Size	Range
Fan speed control	14–22 AWG	500
Zone sensor	16–22 AWG	200

Recommendation: Do not bundle or run interconnection wiring in parallel with or in the same conduit with any high-voltage wires (110 V or greater). Exposure of interconnection wiring to high voltage wiring, inductive loads, or RF transmitters may cause radio frequency interference (RFI). In addition, improper separation may cause electrical noise problems. Therefore, use shielded wire (Belden 83559/83562 or equivalent) in applications that require a high degree of noise immunity. Connect the shield to the chassis ground and tape at the other end.

**Note:** Do not connect any sensor or input circuit to an external ground connection.

**Table 23. Available motor horsepower**

Motor	Unit Voltage	Motor Horsepower			
		0.5	1.00	1.5	3
60 Hz	115/1	X	X	n/a	n/a
	208/1	X	X	n/a	n/a
	230/1	X	X	n/a	n/a
	277/1	X	X	n/a	n/a
	208/3	X	X	X	X
	230/3	X	X	X	X
50 Hz	460/3	X	X	X	X
	220/1	X	X	n/a	n/a
	240/1	X	X	n/a	n/a
	380/3	X	X	X	X
	415/3	X	X	X	X

## MCA and MOP Calculations

### Non-Electric Heat Units

Minimum Circuit Ampacity (MCA) and Maximum Overcurrent Protection (MOP) calculations for non-electric heat units

$$\text{MCA} = 1.25 \times \text{motor FLAs}$$

$$\text{MOP} = 2.25 \times \text{motor FLA}$$

### Electric Heat Units

MCA and MOP calculations for electric heat units

$$\text{Heater amps} = (\text{heater kW} \times 1000) / \text{heater voltage}$$

**Notes:** Use 120V heater voltage for 115V units.  
Use 240V heater voltage for 230V units.  
Use 208V heater voltage for 208V units.  
Use 277V heater voltage for 277V units.  
Use 480V heater voltage for 460V units.

$$\text{MCA} = 1.25 \times (\text{heater amps} + \text{all motor FLAs})$$

$$\text{MOP} = (2.25 \times \text{motor FLA}) + \text{heater amps}$$

HACR (Heating, Air-Conditioning, and Refrigeration) type circuit breakers are required in the branch circuit wiring for all units with electric heat.

Select a standard fuse size equal to the calculated MOP. Use the next smaller size if the calculated MOP does not equal a standard size.

Standard fuse sizes: 15, 20, 25, 30, 35, 40, 45, 50, 60 amps

### Useful Formulas

$$\text{kW} = (\text{cfm} \times \Delta T) / 3145$$

$$\Delta T = (\text{kW} \times 3145) / \text{air flow}$$

$$\text{Single phase amps} = (\text{kW} \times 1000) / \text{voltage}$$

$$\text{Electric heat MBh} = (\text{Heater kW}) (3.413)$$

$$\text{Three-phase amps} = (\text{kW} \times 1000) / (\text{voltage} \times 1.73)$$



## Installation - Electrical

**Table 24. Available electric heat (kW)**

Electrical heat (kW)	Voltage										
	115/60/1	208/60/1	220/50/1	230/60/1	240/50/1	277/60/1	208/60/3	230/60/3	380/50/3	460/60/3	415/50/3
1.0											
1.5						Sizes 12-90					
2.0, 2.5, 3.0											
3.5, 4.0											
4.5											
5.0						Size 18-90					
5.5, 6.0									Size 24-90		
6.5, 7.0, 7.5, 8.0											
9.0, 10.0, 11.0									Size 36-90		
12.0											
13.0, 14.0, 15.0, 16.0									Size 48-90		
17.0, 18.0, 19.0, 20.0									Size 72-90		
21.0											
22.0, 24.0, 26.0, 28.0									Size 90		
30.0											

**Notes:**

1. Magnetic contactors are standard.
2. Units with electric heat are available with or without door interlocking disconnect switch.
3. Units with electric heat are available with or without line fuses.
4. Units with electric heat must not be run below the minimum cfm listed in [Table 25](#).
5. Electric heat is balanced staging: 1 stage = 100 percent, 2 stages = 50 percent/50 percent.

**Table 25. Airflow min/max for BCHD/BCVD blower coils**

Unit Size	12	18	24	36	54	72	90
Nominal cfm	400	600	800	1200	1800	2400	3000
<b>Airflow</b>							
Minimum cfm	250	375	500	750	1125	1500	1875
Maximum cfm	500	675	1000	1600	2400	3000	4000

**Note:** Minimum airflow limits apply to units with hot water or electric heat only. There is no minimum airflow limit on cooling coil units. Maximum airflow limits are to help prevent moisture carryover.

**Table 26. Airflow min/max for BCHD/BCVD blower coils**

Unit Size	24	36	48	60
Nominal cfm	800	1200	1600	2000
<b>Airflow</b>				
Minimum cfm	500	750	1000	1250
Maximum cfm	1000	1500	2000	2500

**Note:** Minimum airflow limits apply to units with hot water or electric heat only. There is no minimum airflow limit on cooling coil units. Maximum airflow limits are to help prevent moisture carryover.

**Table 27. Motor electrical data**

Voltage	Voltage range	Rated HP	Weight (lbs)	FLA
115/60/1	104-127	0.5	14	7.46
115/60/1	104-127	1.0	19	13.3
208/60/1	187-229	0.5	14	4.26
208/60/1	187-229	1.0	19	7.73
230/60/1	207-253	0.5	14	4.26
230/60/1	207-253	1.0	19	7.73
277/60/1	249-305	0.5	14	3.76
277/60/1	249-305	1.0	19	6.73
220/50/1	198-242	0.5	14	4.26
220/50/1	198-242	1.0	19	7.73
240/50/1	216-264	0.5	14	4.26
240/50/1	216-264	1.0	19	7.73
208/60/3	187-229	0.5	13	2.4
208/60/3	187-229	1.0	17	4.6
208/60/3	187-229	1.5	39	7.6
208/60/3	187-229	3.0	56	11.2
230/60/3	207-253	0.5	13	2.6
230/60/3	207-253	1.0	17	4.8
230/60/3	207-253	1.5	39	6.5
230/60/3	207-253	3.0	56	11.2
380/50/3	342-418	0.5	13	1.2
380/50/3	342-418	1.0	18	2.3
380/50/3	342-418	1.5	40	4.2
380/50/3	342-418	3.0	56	5.3
415/50/3	374-457	0.5	13	1.3
415/50/3	374-457	1.0	18	2.4
415/50/3	374-457	1.5	40	4.0
415/50/3	374-457	3.0	56	5.5
460/60/3	414-506	0.5	13	1.3
460/60/3	414-506	1.0	18	2.5
460/60/3	414-506	1.5	40	3.3
460/60/3	414-506	3.0	56	5.5



## ECM Overview and Setup

Blower coil units integrate a Trane electronically commutated motor (ECM) with a VelociTach™ motor control board to deliver outstanding comfort, safety, and performance while greatly reducing energy consumption compared to traditional units with induction AC motors.

This system has a high degree of flexibility and configurability, but with the simplicity of a customized factory configuration appropriate for most installations.

Very little intervention is needed by service and installation personnel in most applications; however, installers must read through the entire document before beginning installation of the new equipment. With proper installation and operation, this unit will have a long service life.

This section focuses on unit motors and controls, including three new circuit modules developed specifically for this series.

**Figure 75. Blower coil with Trane ECM motor**



There are four primary components that enable the technology on your product:

- Trane electronically commutated motor (ECM)
- VelociTach™ motor control board
- Fan speed control (provided when no control package is selected)
- Customer-supplied terminal interface (CSTI)

The motor and control board are combined as a system, and cannot work without each other.

## Trane Electronically Commutated Motor (ECM)

**Figure 76. Trane ECM motor**



- The ECM has integrated electronics, overload protection and short circuit protection. The motor contains no user-serviceable components inside.
- The motor mates to the unit electrically via a single plug that contains both the operating voltage and the control signals that are needed for correct operation.

### **NOTICE**

#### **Equipment Damage!**

**Failure to follow this instruction could result in equipment damage. The motor harness attached to the single plug to which the motor mates contains the very important motor voltage jumper and should not be modified or substituted.**

## VelociTach™ Motor Control Board

The VelociTach motor control board controls and reports the performance of up to two Trane brushless DC (BLDC) motors.

The motor control board also:

- Coordinates the operation of the fan in response to electric heat behavior and electric behavior in response to hydronic heat behavior.
- Incorporates a user interface that allows adjustment of certain unit parameters and provides constant feedback on motor operation.
- Integrates service and troubleshooting tools.
- Integrates a versatile configurable auxiliary temperature sensor.
- Incorporates various safety and lockout features, such as maintaining proper fan speeds if electric heat is called for.

Figure 78. Screen representation of alphabetical characters

A	B	C	D	E	F	G	H	I	J	K	L	M	N	O	P	Q	R	S	T	U	V	W	X	Y	Z
A	b	C	d	E	F	g	H	i	J	K	L	ll	n	O	P	q	r	S	t	U	u	!"	H	Y	2

Figure 79. Screen representation of numerical characters

1	2	3	4	5	6	7	8	9	0
1	2	3	4	5	6	7	8	9	0

## Installation and Initial Setup

### ⚠ WARNING

#### Hazardous Voltage w/Capacitors!

Failure to disconnect power and discharge capacitors before servicing could result in death or serious injury. Disconnect all electric power, including remote disconnects and discharge all motor start/run capacitors before servicing. Follow proper lockout/tagout procedures to ensure the power cannot be inadvertently energized. For variable frequency drives or other energy storing components provided by Trane or others, refer to the appropriate manufacturer's literature for allowable waiting periods for discharge of capacitors. Verify with a CAT III or IV voltmeter rated per NFPA 70E that all capacitors have discharged.

For additional information regarding the safe discharge of capacitors, see PROD-SVB06\*-EN.

### ⚠ WARNING

#### Hazardous Service Procedures!

Failure to follow all precautions in this manual and on the tags, stickers, and labels could result in death or serious injury.

Technicians, in order to protect themselves from potential electrical, mechanical, and chemical hazards, **MUST** follow precautions in this manual and on the tags, stickers, and labels, as well as the following instructions: Unless specified otherwise, disconnect all electrical power including remote disconnect and discharge all energy storing devices such as capacitors before servicing. Follow proper lockout/tagout procedures to ensure the power can not be inadvertently energized. When necessary to work with live electrical components, have a qualified licensed electrician or other individual who has been trained in handling live electrical components perform these tasks.

## Status Display

Figure 77. Status display



The motor control board contains a four-digit, seven-segment display that is used to present information in a format close to real-world language, while having a small-form factor. Most characters are immediately recognizable; however, please consult figures below for the graphical representation of each alphanumeric character.



## ECM Overview and Setup

### Safety Requirements

Follow all recommendations below. Failure to do so could result in death or serious injury.

- The ECM motors contain capacitors which store residual energy. Please keep clear of the fan wheels for 5 minutes after the power has been removed from the system, as a power request with the motor powered off, could result in a very short period of actuation.
- All settings take effect immediately, including fan startup and enabling of electric heat. Caution should be taken to stay clear of hazardous voltages, moving parts and electric heat elements while making adjustments to the VelociTach motor control board. If it is not practical to stay clear of these areas during adjustment of the motor control board, please contact Trane Global Parts for configuration kit that allows easy powering of the motor control board outside of the unit with a 9V battery.
- Changes to switch settings on the CSTI adapter board take effect immediately. Changes should be made to the CSTI configuration switches with the power off.
- Initial hookups to the CSTI and Standard Adapter board, including low voltage interconnections, must be made with the power off.
- Do not make connections to the motors or the adapter boards while power is ON. Do not remove connections to the motor or the adapter boards while the power is ON.
- Do not free spin the fan wheels with your hands while the unit is powered on. The system is constantly scanning and responding to the operational status of the motors.

### Setup

**Note:** Normally, Trane ECMs are configured for soft ramps and transitions between speeds. However, to aid in commissioning of the unit, for approximately 10–15 minutes, the ramps will be shortened to quickly observe proper unit behavior and response to speeds.

For new installations, all boards and motors are pre-installed and pre-configured according to the unit configuration, indicated by its model number.

Under normal and intended operation, the only required intervention specific to the new ECM units is the wiring of:

- Wall-mounted low-voltage fan speed switch inputs to the adapter boards' terminal strips and 24 Vac tap to field-installed fan speed switch.
- Field-supplied controllers/thermostats to the adapter boards' terminal strips and 24 Vac power tap to field-supplied controller/thermostat.
- Adjustment and calibration of the variable speed inputs (VSP/0–10V) on the system.

- Adjustment, calibration or disabling of the optional auto-changeover function on CSTI units.

Otherwise, proceed with the mechanical, electrical and controls installations as defined in other sections of this manual, following all warnings and cautions.

After installation, turn power on.

**Note:** Specifications subject to change without notice. Consult the unit submittals and unit schematics before determining hookup requirements. Terminal block positions, polarities and assignments are determined for specific unit configurations only. Signal assignments are indicated, for reference only.

Both adapter boards come equipped with integrated terminal blocks to hook up to the field supplied/mounted fan speed switches and external controls. Connections should be made to the screw terminals with wires between 16 AWG and 24 AWG, with a ~4–5-mm wire strip length. The terminal blocks have 5-mm spacing, and are equipped with 3-mm screws. The field-supplied wires should have an insulation rating of 600V.

### VelociTach Motor Control Board

#### ⚠ WARNING

##### Safety Alert!

You **MUST** follow all recommendations below. Failure to do so could result in death or serious injury.

All settings take effect immediately, including fan startup and enabling of electric heat. Caution should be taken to stay clear of hazardous voltages, moving parts and electric heat elements while making adjustments to the motor control board. If it is not practical to stay clear of these areas during adjustment of the motor control board, please contact Trane Global Parts for configuration kit that allows easy powering of the motor control board outside of the unit with a 9V battery.

#### ⚠ CAUTION

##### Burn Hazard!

Failure to follow this instruction could result in the unit overheating and becoming hot to the touch, which could result in minor or moderate injury, and/or equipment damage. On electric heat units, certain parameter values are locked out to prevent overheating of the unit. These functions will appear to be saved; however, they will not be accepted if the Electric Heat Protection setting is "On". Do not change the Electric Heat Protection setting to "Off" and make changes to the protected settings unless you are programming an unconfigured service replacement board to match the unit settings on a ECM configuration label.

The motor control board functions and unit specific settings are summarized on the motor control board

configuration label affixed to the back side of the control panel low voltage lid on every unit.

To check status, configuration, or to change settings on the motor control board with the power on the unit, remove the two screws at the top of the low voltage access lid and open. The motor control board will be visible. See the following figure.

**Figure 80. VelociTach motor control board**



The motor control board features a nested menu integrated user interface (UI) that supports:

- Status display for instant touch-free confirmation of unit operation.
- Configuration parameter and value display and modification changes (using integrated menu/set buttons).
- Error code prioritized reporting.

**Note:** Characters on the VelociTach motor control board display appear in red, on a black background.

The display contains decimal positions as well that change position with each parameter, as appropriate. Under normal conditions (i.e., with no error code displayed), the status will loop the following message:

**Table 28. Operational Status Codes**

<p><b>RPM Mode</b> <b>RUNNING/ FAN STATUS</b> <b>CONTINUOUS LOOP</b></p> <p>Displayed when:</p> <ol style="list-style-type: none"> <li>1) No error codes are present</li> <li>2) Motor has completed ramping</li> </ol>	<p><b>r̄tr 1</b> 0000 → 2000</p>	<p>Indicates the current rpm of Motor 1 in the system. "0" rpm here indicate that no fan speed has been requested.</p>
	<p><b>r̄tr 2</b> 0000 → 2000</p>	<p>Indicates the current rpm of Motor 2 in the system. "0" rpm here indicate a fan off condition OR a fan "missing" condition<sup>(a)</sup>.</p>
	<p><b>FSt 1</b></p>	<p>Indicates the status being calculated or Fan Motor 1. If "off," this indicates that either:</p> <ol style="list-style-type: none"> <li>1) No fan speed is being requested or</li> <li>2) The fan performance is failing to meet the request; refer to "ECM Motors," p. 128 for additional troubleshooting information.</li> </ol> <p>If "on," this indicates that the fan is performing correctly and will be used to report fan status correctly, depending on <b>FPru</b> mode.</p>
	<p><b>YES / no</b></p>	
	<p><b>FSt 2</b></p>	<p>Indicates the status being calculated or Fan Motor 2. If "off," this indicates that either:</p> <ol style="list-style-type: none"> <li>1) No fan speed is being requested or</li> <li>2) The fan performance is failing to meet the request; refer to "ECM Motors," p. 128 for additional troubleshooting information.</li> <li>3) If the target speed for Motor 2 is "0," this is used to indicate a missing motor <sup>(a)</sup>.</li> </ol> <p>If "on," this indicates that the fan is performing correctly and will be used to report fan status correctly, depending on <b>FPru</b> mode.</p>
	<p><b>YES / no</b></p>	
	<p><b>EhEn</b></p>	<p>Indicates that the temperature sensing circuit has calculated a logical "on" based on the settings of the following parameters:</p>
<p><b>YES / no</b></p>	<p><b>A 127 / A 126 / A 1PU</b></p>	

(a) Motor 1 is the only motor in fan coil units.

## User Interface

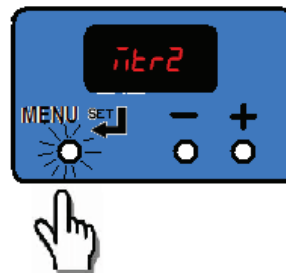
The VelociTach motor control board's on-board user interface is easy to use and supports:

- Verification/auditing of on-board parameter settings (read-only)
- Adjustment of the on-board settings (write)

The user interface has three input buttons (see [Figure 81, p. 70](#)), from left to right:

- Menu/Set
- Decrement
- Increment

**Figure 81. User interface input buttons**



Each button has several different actuation levels depending on length of press, and what the UI is currently displaying.

**Table 29. Button actuation levels**

Button	Duration	Action	Menu/Set
Short Press in Status Display	< 1 sec	None	
Short Press in Configuration Display		Toggles between parameter name and value without saving (abandons value if changed).	
Long Press/Hold in Status Display	> 3 sec	Enters the configuration menu	
Long Press/Hold in Configuration Display	> 3 sec	If on a parameter name, toggles to the value. If on a parameter value, saves the value settings and returns to the parameter name as confirmation.	

Button	Duration	Action	Decrement
Short Press in Status Display	< 1 sec	None	
Short Press in Configuration Display	< 1 sec	Scrolls through parameter names, or decreases value of parameter.	
Long Press/Hold in Status Display	> 3 sec	n/a	
Long Press/Hold in Configuration Display	> 3 sec	Faster scroll through parameter name, or faster decrease of values of parameters.	

Button	Duration	Action	Increment
Short Press in Status Display	< 1 sec	None	
Short Press in Configuration Display	< 1 sec	Scrolls through parameter names, or increases value of parameter.	
Long Press/Hold in Status Display	> 3 sec	n/a	
Long Press/Hold in Configuration Display	> 3 sec	Faster scroll through parameter name, or faster increase of values of parameters.	

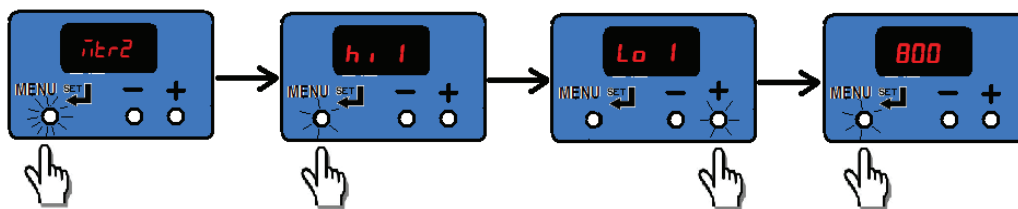
## Configuration Examples

**Example 1-** View the value parameters without saving.

Verify the low speed value for motor 1 is set to 800 rpm.

Start with the motor control board scrolling status display and proceed as follows:

**Figure 82. Verify low speed value**

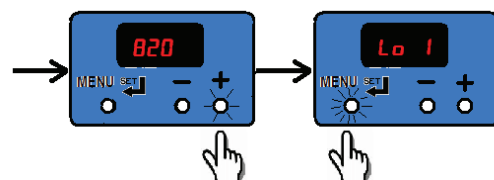


**Example 2** - Change the value of low speed to 820 rpm.

Continue from the previous example as shown below, using a long press to “save” the new desired value.

*If the display has timed out and returned to the status loop, repeat Example 1 to arrive back at this example’s starting point.*

**Figure 83. Change value of low speed value**

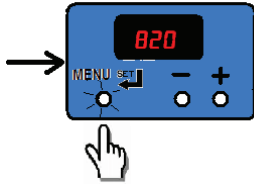


## ECM Overview and Setup

**Example 3** - Double-check the value of 820 rpm has been saved.

If the display has timed out and returned to the status loop, repeat Example 1 and Example 2 to arrive back at this example's starting point.

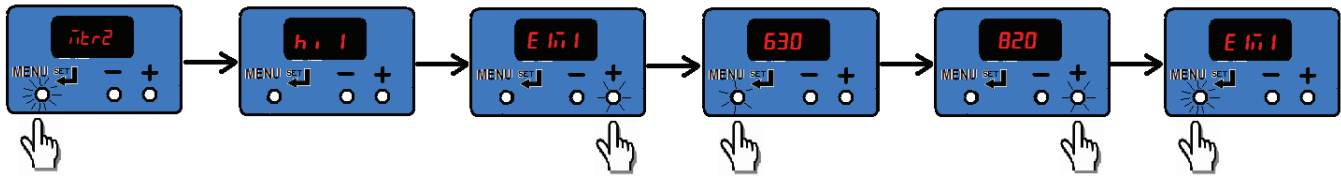
Figure 84. Verify value of 820 rpm



**Example 4** - Change the value of a protected value on an electric heat unit.

It appears the value has been changed, but after checking the value, the original value has been retained.

Figure 85. Change value on electric heat unit



### Priority/Error Display

Under special conditions, the status display will interrupt briefly to prioritize display of events:

**Notes:**

- During error displays, the user interface will be disabled, until the error is removed or resolved.
- If changes are made to parameters and saved, most settings take effect immediately. Any change to fan speeds will take effect and cause the configuration menu to exit immediately to begin tracking speeds via the on-board tachometer.
- If a error occurs while the configuration menu is in effect, all unsaved values will be discarded and the error codes will be displayed.

**Table 30. Error Codes**

Displayed during abnormal operation.	<b>Motor 1 LOCH</b>	Indicates a locked rotor condition of Motor 1. The motor will be locked out until the cause has been resolved, and the power cycled; refer to “ECM Motors,” p. 128 for resolution details.  Fan Status function, if being used, will report an inoperative motor. Electric heat and changeover heat will be shut down.
	<b>Motor 2 LOCH</b>	Indicates a locked rotor condition of Motor 2. The motor will be locked out until the cause has been resolved, and the power cycled; refer to “ECM Motors,” p. 128 for resolution details.  Motor 1 will continue to operate, but will not be monitored. Fan Status function, if being used, will report an inoperative motor. Electric heat and changeover heat will be shut down.
	<b>Motor 1 OSPd</b>	Indicates that Motor 1 has experienced a run-away or over speed condition, and has been shutdown. The unit will offer limited “limp-in” performance, and Motor 2 will continue to operate, but will not be monitored. Fan Status function, if being used, will report an inoperative motor.  Refer to “ECM Motors,” p. 128 to reset, the cause must be resolved and the power to the unit cycled. Electric heat and changeover heat will be shut down.
	<b>Motor 2 OSPd</b>	Indicates that Motor 2 has experienced a run-away or over speed condition, and has been shutdown. The unit will offer limited “limp-in” performance, and Motor 1 will continue to operate, but will not be monitored. Fan Status function, if being used, will report an inoperative motor.  Refer to “ECM Motors,” p. 128 to reset, the cause must be resolved and the power to the unit cycled. Electric heat and changeover heat will be shut down.
	<b>rAMP 0000 → 2000 2000 → 0000</b>	Indicates the motor is transitioning between speeds, ramping up or down. The message “RAMP” is briefly displayed, followed by the target speed for “Motor 1” only. Once the target speed has been reached, the status display will resume operation.
	<b>v 123</b>	On power on, the version of software is briefly displayed, followed by the results of a POST (power on self test).

**Note:** Fan coil units have only Motor 1 installed.

## Adjustments

After connections of power and hookup of customer installed controls/fan speed control and under normal operative conditions, the only adjustments needed to be made to the motor control board during commissioning of the unit are:

- Adjustment and calibration of the variable speed inputs (VSP/0–10V) on the system, where applicable.
- Adjustment, calibration or disabling of the optional auto-changeover function on CSTI units, where applicable.

In addition, the CSTI adapter board offers configurability that can be used in special cases to adjust the following operation of the unit:

- Courtesy cooling/main valve logic inversion relays for use with normally open valves
- Courtesy heating/auxiliary valve logic inversion relays for use with normally open valves
- Changeover function for use with changeover coils (in conjunction with the motor control board)

The switches are factory-set based on the model number configuration as ordered; however, the information is provided below to aid in the understanding of the operation of the system.

## Adjusting Variable Speed Inputs

### **WARNING**

#### **Hazardous Voltage w/Capacitors!**

**Failure to disconnect power and discharge capacitors before servicing could result in death or serious injury. Disconnect all electric power, including remote disconnects and discharge all motor start/run capacitors before servicing. Follow proper lockout/tagout procedures to ensure the power cannot be inadvertently energized. For variable frequency drives or other energy storing components provided by Trane or others, refer to the appropriate manufacturer’s literature for allowable waiting periods for discharge of capacitors. Verify with a CAT III or IV voltmeter rated per NFPA 70E that all capacitors have discharged.**

**For additional information regarding the safe discharge of capacitors, see PROD-SVB06\*-EN.**

**⚠ WARNING**
**Safety Alert!**

You **MUST** follow all recommendations below. Failure to do so could result in death or serious injury. All settings take effect immediately, including fan startup and enabling of electric heat. Caution should be taken to stay clear of hazardous voltages, moving parts and electric heat elements while making adjustments to the motor control board. If it is not practical to stay clear of these areas during adjustment of the motor control board, please contact Trane Global Parts for configuration kit that allows easy powering of the motor control board outside of the unit with a 9V battery.

**⚠ CAUTION**
**Burn Hazard!**

Failure to follow this instruction could result in the unit overheating and becoming hot to the touch, which could result in minor or moderate injury, and/or equipment damage. On electric heat units, certain parameter values are locked out to prevent overheating of the unit. These functions will appear to be saved; however, they will not be accepted if the Electric Heat Protection setting is "On". Do not change the Electric Heat Protection setting to "Off" and make changes to the protected settings unless you are programming an unconfigured service replacement board to match the unit settings on a motor control board configuration label.

**NOTICE:**
**Equipment Damage!**

You **MUST** follow all recommendations below. Failure to do so could result in equipment damage.

- Care should be taken in the system to use a single 24 Vac supply system to avoid damage to equipment.
- Care should be taken to observe proper polarity and grounding in the hookup of the 0–10V system to avoid damage to equipment.

**Note:** Configuration adjustments to the motor control board should be made through the **SMALLER** of the two low-voltage lids on the front of the control panel, through the low-voltage insulation/shielding.

- The 0–10V (variable speed) inputs are available for use, but are not mandatory. The ECM system comes standard with three to five field-accessible thermostatic inputs (with adjustable speed), so the use of the 0–10V inputs is optional.
- All inputs are independently configurable and simultaneously accessible, and the motor control board will choose the highest user (configured and

requested) speed. However, care should be taken with customer controls to avoid contention of signals.

The motor control board and adapter boards offer standard, normalizing 0–10V Variable speed fan inputs for use with field supplied controllers or thermostats. These inputs can be used as the only input to the system, used in addition to the thermostatic (H, M, L) inputs, or not used at all. The inputs are accessible via 1TB4 on the adapter boards.

The motor control board is factory configured to drive the unit to a minimum speed (catalogue "low speed" value), defined as  $AL_{i1}$  and  $AL_{i2}$  once the analog (0–10V) input is honored. As a default, the noise floor/threshold is set to 3 percent (0.3V). At 0.3V, the system will drive the motors to the speeds defined in defined as  $AL_{i1}$  and  $AL_{i2}$ . If the analogue input goes to 10V, the motor control board will drive the motor to maximum speed (normally catalogue "high speed" value), defined as  $Ah_{i1}$  and  $Ah_{i2}$ , and will change speed in response.

Although the VelociTach motor control board ships with settings that will work with most 0–10 VDC outputs, calibration should be performed to maximize response range and controller authority. Typically, the only settings needed for the VSP inputs are calibration of the signal to ensure that the system obeys the following rules:

- The minimum output from the field supplied controller is met with a positive fan response. That is, we do not want the  $\mu FLR$  setting on the motor control board to be higher than the minimum output of the field supplied controller, as the motor control board will "ignore" a portion of the usable range of the customer fan variable speed output.
- The minimum output from the field supplied controller is not significantly greater than the floor setting  $\mu FLR$  floor. If the minimum output of the controller is significantly greater than the floor setting, the first point that the motor will turn on will be above the  $AL_{i1}$  and  $AL_{i2}$  value. The full range of motor control will not be fully utilized in this case, as the motor will never reach the low speed motor analogue input scaling value for Motor 1 and Motor 2 ( $AL_{i1}$  and  $AL_{i2}$ )
- The maximum output of the controller needs to be 10V, or if lower, needs to be compensated using the analog input scaling value,  $AISC$  to normalize the operational range. As a default, the scaling value is set to 1.00 (so a voltage of 5V will be graded as 5V); however, to compensate for long runs or lower max voltages (i.e., lower than 10.00), the scaling value can be increased accordingly to maximize operational range.  
For example, if the voltage is only reaching a value of 9.0V at the adapter boards, then the  $AISC$  parameter should be set to  $(10/9) = 1.111$ . If left un-calibrated, the unit will never attain maximum speeds, defined as  $Ah_{i1}$  and  $Ah_{i2}$ .

- The motor control board can accept slightly over-biased inputs up to 12 VDC, and the  $R_{iSc}$  parameter can be set to a value less than 1.0 to compensate.

### VSP Setup Examples

Figure 86. Example 1:  $\omega_{FLr}$  set too high and  $R_{iSc}$  set too high

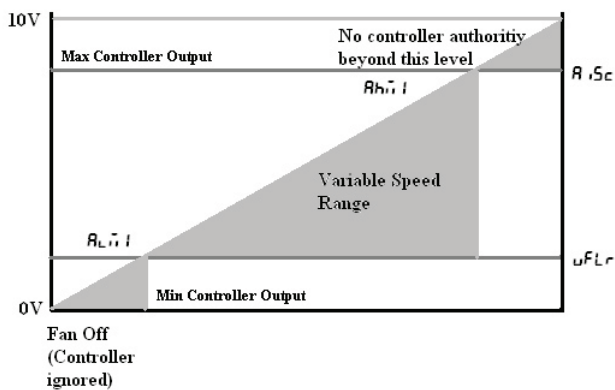


Figure 87. Example 2:  $\omega_{FLr}$  set too high but  $R_{iSc}$  set correctly

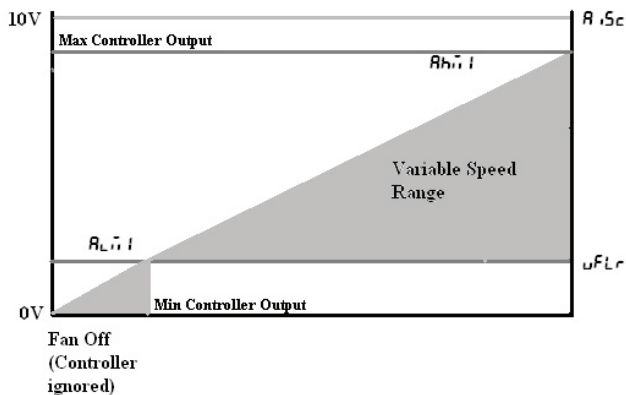
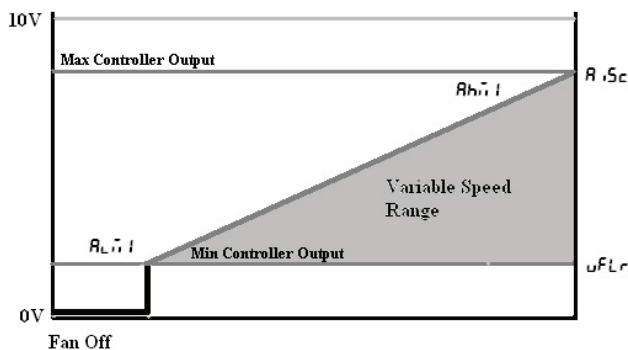


Figure 88. Example 3:  $\omega_{FLr}$  set correctly and  $R_{iSc}$  set correctly



### Potentiometer/Rheostat For VSP

#### ⚠ WARNING

#### Hazardous Voltage w/Capacitors!

Failure to disconnect power and discharge capacitors before servicing could result in death or serious injury. Disconnect all electric power, including remote disconnects and discharge all motor start/run capacitors before servicing. Follow proper lockout/tagout procedures to ensure the power cannot be inadvertently energized. For variable frequency drives or other energy storing components provided by Trane or others, refer to the appropriate manufacturer's literature for allowable waiting periods for discharge of capacitors. Verify with a CAT III or IV voltmeter rated per NFPA 70E that all capacitors have discharged.

For additional information regarding the safe discharge of capacitors, see PROD-SVB06\*-EN.

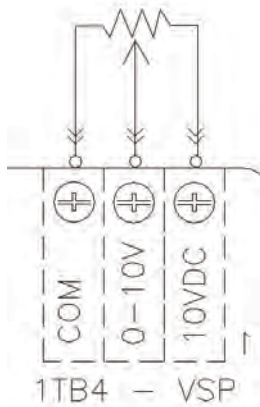
#### ⚠ WARNING

#### Safety Alert!

You MUST follow all recommendations below. Failure to do so could result in death or serious injury. All settings take effect immediately, including fan startup, enabling of electric heat. Caution should be taken to stay clear of hazardous voltages, moving parts and electric heat elements while making adjustments to the motor control board. If it is not practical to stay clear of these areas during adjustment of the motor control board, please contact Trane Global Parts for configuration kit that allows easy powering of the motor control board outside of the unit with a 9V battery.

A courtesy 10 VDC supply is provided that can support a 10-mA draw. The use of a 1K or a 10K potentiometer is recommended, and only a stand-alone potentiometer (not shared with any other electrical system) should be employed. When a simple potentiometer is used as depicted in the following figure, the  $\omega_{FLr}$  setting will define a null-zone (off).

The typical connection is depicted in the following figure; however, please consult the unit schematic for the most updated instruction, as this is provided as reference only.

**Figure 89. Typical connection**


## Adjusting Optional Auto-Changeover Function on CSTI Units

### ⚠ WARNING

#### Hazardous Voltage w/Capacitors!

Failure to disconnect power and discharge capacitors before servicing could result in death or serious injury. Disconnect all electric power, including remote disconnects and discharge all motor start/run capacitors before servicing. Follow proper lockout/tagout procedures to ensure the power cannot be inadvertently energized. For variable frequency drives or other energy storing components provided by Trane or others, refer to the appropriate manufacturer's literature for allowable waiting periods for discharge of capacitors. Verify with a CAT III or IV voltmeter rated per NFPA 70E that all capacitors have discharged.

For additional information regarding the safe discharge of capacitors, see PROD-SVB06\*-EN.

The motor control board provides additional temperature controlled logic to help coordinate certain electric-heat and valve logic functions:

- On units with electric heat and a changeover coil, the motor control board and adapter boards are pre-configured to cause hydronic heat and electric heat to be mutually exclusive:
  - On units with ComfortLink™ controls (Tracer® ZN controllers) or BacNet™ controls (UC400-B), the Tracer® ZN controller board will serve as the primary logic to select the electric heat only if hot water is not available, but the motor control board will service as a backup lockout.
  - On units with Customer Supplied Controllers (CSTI units), the motor control board and CSTI board will serve as the primary lockout.
- On CSTI units selected with a changeover coil configuration, the motor control board is factory configured to work in conjunction with the CSTI

adapter board to provide a useful auto-changeover function. Traditionally, a fixed setpoint bi-metallic disc temperature switch is used to provide changeover with customer controls; however, the motor control board has defeatable and configurable bi-metallic disc temperature switch emulation when combined with the CSTI adapter board. The motor control board is preconfigured for typical values, so changeover settings do not necessarily need to be changed.

- An NTC thermistor is supplied and affixed to the supply pipes where applicable. The motor control board has several settings that affect the operation of the changeover function:
  - $FP_{RU}$  parameter should normally be set to  $E_{HL}$  or  $E_{HFS}$  to use the changeover functions.
  - $E_{HL}$  parameter should be chosen if the unit has a changeover coil without electric heat.
  - $E_{HFS}$  parameter should be chosen if the unit has a changeover coil with electric heat. Generally, this will perform the same as the  $E_{HL}$  parameter but in addition, will disable heating function on electric heat and on the changeover coil if there are fan failures. The auxiliary heating coil function will continue to operate and respond to the customer heating request.
- $A_{iPU}$  parameter should be set to  $I_n$  for CSTI units and to  $OU_{E}$  for ComfortLink or BacNet controller units.
- $A_{i2i}$  parameter defines the temperature at which the motor control board will close the triac onboard the motor control board (if  $FP_{RU}$  parameter is set correctly).
- $A_{i2b}$  parameter defines the temperature at which the motor control board will open the triac onboard the motor control board (if  $FP_{RU}$  parameter is set correctly). By leaving a "gap" between the make and break value, we will simulate hysteresis of a real bi-metallic disc temperature switch.
- When combined with the CSTI adapter board, the bi-metallic disc temperature switch emulation and the electric heat lockout function will work when the switches are set correctly.

## Configurations

Every Trane unit with ECM motors will have modules specifically configured at the factory for the operation of that unit. The motor control board configuration label is affixed to the low-voltage access lid on the outside of the control panel. The VelociTach motor control board label may be on the back-side of the low voltage access lid, depending on the unit configuration.

The serial number of each unit and the custom configuration settings specific to that unit will be printed on the label for convenient matching of labels/settings to specific units. Programming a unit with the settings from

another unit will result in abnormal operation. The label contains four important sections:

- How to enter the configuration menu
- The description and meaning of the error codes
- The description and meaning of the status display
- The parameter names and values specific to that unit

Figure 90. Motor control board label

O/N: MKT264A			
Serial Number: T12C13218			
Values for this unit are shown below. Do not change values unless replacing module.			
Description	Name	Value	
Mtr1 high Spd	HI 1	1076	
Mtr1 Med Spd	Med 1	765	
Mtr1 Low Spd	LO 1	621	
EHStg1 Mtr1 Spd	E 1 1	0	
EH Stg2 Mtr1 Spd	E 2 1	0	
AI High Spd Mtr1	AH 1	1076	
AI Low Spd Mtr1	AL 1	621	
Mtr2 High Spd	HI 2	0	
Mtr2 Med Spd	Med 2	0	
Mtr2 Low Spd	LO 2	0	
EHStg1 Mtr2 Spd	E 1 2	0	
EH Stg2 Mtr2 Spd	E 2 2	0	
AI High Spd Mtr2	AH 2	0	
AI Low Spd Mtr2	AL 2	0	
Mt1 Hgh PWM Lt	1 HI	70.00	
Mt2 Hgh PWM Lt	2 HI	70.00	
Fan Proving Fct	FP-U	FnsE	
Ht Sens Resistor	AI PU	00E	
Protect Func	AI PE	OFF	

**Note:** This label is provided for reference only, as an example, and should not be used to configure the unit.

## Motor Control Board Settings

### ⚠ WARNING

#### Safety Alert!

You **MUST** follow all recommendations below. Failure to do so could result in death or serious injury. All settings take effect immediately, including fan startup and enabling of electric heat. Caution should be taken to stay clear of hazardous voltages, moving parts and electric heat elements while making adjustments to the motor control board. If it is not practical to stay clear of these areas during adjustment of the motor control board, please contact Trane Global Parts for configuration kit that allows easy powering of the motor control board outside of the unit with a 9V battery.

### ⚠ CAUTION

#### Burn Hazard!

Failure to follow this instruction could result in the unit overheating and becoming hot to the touch, which could result in minor or moderate injury, and/or equipment damage. On electric heat units, certain parameter values are locked out to prevent overheating of the unit. These functions will appear to be saved; however, they will not be accepted if the Electric Heat Protection setting is "On". Do not change the Electric Heat Protection setting to "Off" and make changes to the protected settings unless you are programming an unconfigured service replacement board to match the unit settings on a ECM configuration label.

### NOTICE:

#### Equipment Damage!

Do not change the PWM output voltage settings as motor damage could occur.

**Note:** The motor control board functions and unit specific settings are summarized on the motor control board configuration label affixed to the back side of the control panel low voltage lid, on every unit.

The following table lists the parameter names and typical settings of the motor control board, for reference only.

Do not change the electric heat protection settings if your unit has electric heat.

If the format setting for rpm values are not correct (i.e., not four-digit: XXXX), please check the operation mode of the motor control board **Mod 1** and **Mod 2** and motor signal output format **S1 9 1** and **S1 9 2**.

**Note:** The following notes are provided for reference only, and the motor control board label must be used as the ultimate guide for setting up an motor control board on specific units.



## ECM Overview and Setup

**Table 31. Configuration settings of the motor control board (for reference only)**

Description on Unit Label	User Interface Name	Typical User Interface Value	Description	
Mtr 1 High Spd	H 1	1080	Sets the high-speed rpm for Motor 1.	Do not exceed 2300 rpm.
Mtr 1 Med Spd	hd 1	777	Sets the medium-speed rpm for Motor 1.	
Mtr 1 Low Spd	Lo 1	632	Sets the low-speed rpm for Motor 1.	Do not set under 600 rpm.
EHStg1 Mtr1 Spd	E h 1	0	Assigns an rpm to be associated with a call for 1 <sup>st</sup> stage electric heat, for Motor 1 (only on units equipped with electric heat).	E h 1, E h 2, E 2 h 1, E 2 h 2 settings are locked out on units with electric heat.
EH Stg 2 Mtr 1 Spd	E 2 h 1	0	Assigns an rpm to be associated with a call for 2 <sup>nd</sup> stage electric heat, for Motor 1 (only on electric heat equipped units).	
AI High Spd Mtr 1	Ah 1	0	Sets the maximum rpm for Motor 1 for the maximum input value of the analog input.	Analog inputs below the uFLr setting will be rejected.
AI Low Spd Mtr 1	AL 1	0	Sets the minimum turn-on rpm for Motor 1, when the analog input becomes active.	
Mtr 2 Hgh Spd	H 2	0	Sets the high-speed rpm for Motor 2.	Blower coils have only one motor.
Mtr 2 Med Spd	hd 2	0	Sets the medium-speed rpm for Motor 2.	
Mtr 2 Low Spd	Lo 2	0	Sets the low-speed rpm for Motor 2.	
EHStg1 Mtr2 Spd	E h 2	0	Assigns an rpm to be associated with a call for 1 <sup>st</sup> stage electric heat, for Motor 2 (only on electric heat equipped units).	If the unit has only one motor, all seven speed settings for the second motor (H 2, hd 2, Lo 2, E h 2, E 2 h 2, AL 2, Ah 2) should be set to zero.
EH Stg 2 Mtr 2 Spd	E 2 h 2	0	Assigns an rpm to be associated with a call for 2 <sup>nd</sup> stage electric heat, for Motor 2 (only on electric heat equipped units).	
AI High Spd Mtr 2	Ah 2	0	Sets the maximum rpm for Motor 2 for the maximum input value of the analog input.	
AI Low Spd Mtr 2	AL 2	0	Sets the minimum turn-on rpm for Motor 2, when the analog input becomes active.	
Op Mode Mtr 1	h od 1	r P h	Sets the operational mode for Motor 1.	Must be set to r P h for blower coil units.
Op Mode Mtr 2	h od 2	r P h	Sets the operational mode for Motor 2.	Must be set to r P h for blower coil units.
Mtr 1 Out Format	S 1 9 1	P 1 h	Sets the interface type for Motor 1.	Must be set to P 1 h for blower coil units.
Mtr 2 Out Format	S 1 9 2	P 1 h	Sets the interface type for Motor 2	Must be set to P 1 h for blower coil units.
Mtr 1/2 PWM Freq.	F r E 9	100	Sets the PWM frequency, for cases when the PWM outputs are used.	On blower coil units, the P 1 h must not be changed.
Mtr 1 PWM Volt	h 1 u L	5	Sets the PWM voltage, for cases when the PWM outputs are used.	This setting must NOT be changed, as damage to the motor may occur!
Mtr 2 PWM Volt	h 2 u L	5	Sets the PWM voltage, for cases when the PWM outputs are used.	This setting must NOT be changed, as damage to the motor may occur!
Mt1 Hgh PWM Lt	h 1 h 1	90	Sets the maximum output percentage that the controller will request from Motor 1.	This envelope protection value should not be altered.
Mt1 Low PWM Lt	h 1 Lo	14.5	Sets the minimum maximum output percentage that the controller will request from Motor 1.	This envelope protection value should not be altered.
Mt2 Hgh PWM Lt	h 2 h 1	90	Sets the maximum output percentage that the controller will request from Motor 2.	This envelope protection value should not be altered.
Mt2 Low PWM Lt	h 2 Lo	14.5	Sets the minimum maximum output percentage that the controller will request from Motor 2.	This envelope protection value should not be altered.
Mt1 Ovspd RPM	r P h 1	2500	Selects the rpm above which the Motor 1 will be assumed to be in an overspeed condition and will need to be shut down.	This envelope protection value should not be altered.
Mt2 Ovspd RPM	r P h 2	2500	Selects the rpm above which the Motor 2 will be assumed to be in an overspeed condition and will need to be shut down.	This envelope protection value should not be altered.
Fan Proving Fct	F P r u	F n S t	Selects which mode should be assigned to the Binary output circuit, depending on unit type.	This setting has to be correct for proper unit operation of electric heat and changeover units.

**Table 31. Configuration settings of the motor control board (for reference only)**

Description on Unit Label	User Interface Name	Typical User Interface Value	Description	
<i>AI Boost Amp</i>	<b>A 1Sc</b>	<b>1</b>	Boosts or attenuates the analog input signal to compensate for long wire runs.	A value of <b>1</b> should be used if no voltage level compensation is needed (i.e., voltage peak is at 10 VDC).
<i>AI Floor</i>	<b>uFLr</b>	<b>0.5</b>	Rejects noise on the analog input lines and sets up the motor control board to turn on if the thermostat or controller is commanding its analog outputs on.	
<i>PulsePerRev</i>	<b>FdbH</b>	<b>18</b>	Sets up the tachometer function to be compatible with the on-board motor and for correct speed calculation and calibration.	Do not change this setting as this is critical to proper unit operation.
<i>P Value Mtr 1</i>	<b>PuL 1</b>	<b>0.03</b>	Sets up the on board closed loop control to control Motor 1 with proper stability.	Do not change this setting.
<i>I Value Mtr 1</i>	<b>I uL 1</b>	<b>0.03</b>	Sets up the on board closed loop control to control Motor 1 with proper stability.	Do not change this setting.
<i>P Value Mtr 2</i>	<b>PuL 2</b>	<b>0.03</b>	Sets up the on board closed loop control to control Motor 2 with proper stability.	Do not change this setting.
<i>I Value Mtr 2</i>	<b>I uL 2</b>	<b>0.03</b>	Sets up the on board closed loop control to control Motor 2 with proper stability.	Do not change this setting.
<i>Ht Sens Mk Val F</i>	<b>A 12i</b>	<b>85</b>	Sets the make value for the motor control board triac output based on the thermistor input.	Operation also depends on <b>FPrU</b> , <b>A 12b</b> , and <b>A 1PU</b> settings.
<i>Ht Sens Bk Val F</i>	<b>A 12b</b>	<b>90</b>	Sets the break value for the motor control board triac output based on the thermistor input.	Operation also depends on <b>FPrU</b> , <b>A 12i</b> , and <b>A 1PU</b> settings.
<i>Ht Sens Resistor</i>	<b>A 1PU</b>	<b>oUt</b>	Sets the input impedance of the thermistor input.	Should be pre-set to "OUT" for Tracer® ZN controllers.
<i>Mt 1 Ramp %/sec</i>	<b>i 1rP</b>	<b>3</b>	Sets the ramp rate for Motor 1, in % per second.	
<i>Mt 2 Ramp %/sec</i>	<b>i 2rP</b>	<b>3</b>	Sets the ramp rate for Motor 2, in % per second.	
<i>EH Ramp Accel</i>	<b>EhrP</b>	<b>2</b>	Sets the acceleration factor for the electric heat inputs.	Is used to force faster ramps when electric heat is requested.
<i>Ramp MAX Time</i>	<b>i hrP</b>	<b>15</b>	Sets the maximum ramp time for both Motor 1 and Motor 2 (in seconds).	Overrides the ramp rates <b>i 1rP</b> and <b>i 2rP</b> if the calculated ramp time exceeds <b>i hrP</b> .
<i>EH Fan off delay</i>	<b>EHDL</b>	<b>15</b>	Selects how long the fan needs to stay on after an electric heat request has been turned off.	Not used on fan-coil unit.
<i>Lck Rtr Protect</i>	<b>LrPt</b>	<b>on</b>	Selects whether to use the on-board locked rotor protection function.	This will shut down the affected motor, if rotational response is not detected.
<i>Protect Funct</i>	<b>EhPt</b>	<b>on</b>	This function protects settings on the board that affect the safety of the electric heat system.	Do NOT change this setting. This setting locks out the following parameters from being changed, for safe operation of the unit.  <b>A 1PU</b> <b>FPrU</b> <b>A iH</b> <b>A 1bH</b> <b>E i 1</b> <b>E i 2</b> <b>E 2i 1</b> <b>E 2i 2</b> <b>S 19</b> <b>i od 1</b> <b>i od 2</b> <b>i 1H 1</b> <b>i 1Lo</b>



## ECM Overview and Setup

**Table 31. Configuration settings of the motor control board (for reference only)**

Description on Unit Label	User Interface Name	Typical User Interface Value	Description	
Protect Funct	EhPt	FLA	This his function protects settings on the board that affect the safety of the electric heat system, and limit the maximum current the motor will draw under any operating condition.	Do NOT change this setting. This setting locks out the following parameters from being changed, for safe operation of the unit. E 17 1 E27 1 E 17 2 E27 2 70d 1 70d 2 S1 9 1 S1 9 2 71 HI 71 LO 72 HI 72 LO FP ru A 127 A 12b AI PU
Rmp dft (auto rst)	rPdF	oFF	This function shortens the ramps for faster unit commissioning and auto-resets to off after approximately 15 minutes of power-on operation.	To aid in commissioning of the unit, for approximately 10–15 minutes, the ramps will be shortened to quickly observe proper unit behavior and response to speeds.
Soft Rev	SoFt	uH_HH	Displays the software version.	Module should be received with most recent version.

### Fan Speed Response Verification

- After performing controller specific commissioning, observe the display on the motor control board with the power on, to the unit. The motor control board display should display a looping status indicator as follows:

```
71r 1 → 0 → 71r 2 → 0 → FSt 1 → 0
FF → FSt 2 →
OFF → EhEn → On
```

**Notes:**

- The EhEn indicator is unit-specific and may indicate "Off" at this point; refer to thermistor function for more information.
  - A representative fan speed of "1080" rpm are shown in the example below. Each unit is factory-configured differently and will have different settings for different fan speeds.
- While the unit remains on, exercise the fan controls on the unit, either directly or indirectly through request for unit heat/cool. Observe the fan spinning, and then observe the fan display on the motor control board. It should display a looping status indicator as follows:

For a size 200, 300, 400, 600, or 800 unit (using typical unit operating fan speeds):

```
71r 1 → 1080 → 71r 2 → 0 → FSt 1
→ On → FSt 2 →
OFF → EhEn → On
```

For a size 1000 or 1200 unit (using typical unit operating fan speeds):

```
71r 1 → 1080 → 71r 2 → 1080 → FSt
1 → On → FSt 2 →
on → EhEn → On
```

**Note:** The EhEn indicator is unit-specific and may indicate "Off" at this point; refer to thermistor function for more information.

- OPTIONAL:

While the fan is running, if practical, change the fan speeds and observe the display temporarily indicate: rAIP

Exercise all fan speeds to ensure positive unit response and to validate any field wiring.



# Start-Up

## Pre-Startup Checklist

Complete this checklist after installing the unit to verify all recommended installation procedures are complete before unit startup. This does not replace the detailed instructions in the appropriate sections of this manual. Disconnect electrical power before performing this checklist. Always read the entire section carefully to become familiar with the procedures.

### **⚠ WARNING**

#### **Hazardous Voltage w/Capacitors!**

Failure to disconnect power and discharge capacitors before servicing could result in death or serious injury. Disconnect all electric power, including remote disconnects and discharge all motor start/run capacitors before servicing. Follow proper lockout/tagout procedures to ensure the power cannot be inadvertently energized. For variable frequency drives or other energy storing components provided by Trane or others, refer to the appropriate manufacturer's literature for allowable waiting periods for discharge of capacitors. Verify with a CAT III or IV voltmeter rated per NFPA 70E that all capacitors have discharged.

For additional information regarding the safe discharge of capacitors, see PROD-SVB06\*-EN.

**Note:** Some circumstances may require the unit to run before building construction is complete. These operating conditions may be beyond the design parameters of the unit and may adversely affect the unit.

### General Checks

- Ensure the unit has been installed level.
- Ensure supply-air and return-air ducts have been connected.
- Ensure damper operator motors and connecting linkage have been installed.
- Verify damper operation and linkage alignment.
- Check that air filters are in place and positioned properly.
- Remove any debris from the unit interior.
- Remove all foreign material from the drain pan and check drain pan opening and condensate line for obstructions.
- Inspect electrical connections to the unit and unit controllers.
  - Connections should be clean and secure.
  - Compare the actual wiring with the unit diagrams.
  - Reference the appropriate controller manual for more details about starting units with factory-mounted controls.

- Check piping and valves for leaks. Open or close the valves to check for proper operation. Drain lines should be open.
- Leave this manual with the unit.

### Fan-Related Checks

- Rotate fan wheel manually to confirm it turns freely in the proper direction.
- Verify the fan and motor are aligned.

### Coil-Related Checks

#### **NOTICE:**

#### **Proper Water Treatment!**

The use of untreated or improperly treated water in a CenTraVac could result in scaling, erosion, corrosion, algae or slime. It is recommended that the services of a qualified water treatment specialist be engaged to determine what water treatment, if any, is required. Trane assumes no responsibility for equipment failures which result from untreated or improperly treated water, or saline or brackish water.

- Ensure coil and condensate drain piping connections are complete.
- Check the piping and valves for leaks.
  - Open or close the valves to check operation.
  - The drain lines should be open.
- Remove all foreign material from the drain pan and check the pan opening and condensate line for obstructions.
- For steam coils, slowly turn the steam on full for at least 10 minutes before opening the fresh air intake on units with fresh air dampers.

### Electrical Checks

- Check all electrical connections for tightness.
- Verify motor voltage and amps on all phases with the unit nameplate ratings to ensure unit operates correctly.

### Ductwork Checks

- If using return ductwork to the unit, secure it with three inches of flexible duct connector.
- Extend discharge duct upward without change in size or direction for at least one and one half fan diameters.
- Use a 3-inch flexible duct connection on discharge.
- Ensure trunk ductwork is complete and secure to prevent leaks.
- Verify that all ductwork conforms to NFPA 90A or 90B and all applicable local codes

## Unit Startup

### Thermostat

The high voltage thermostat can be used for two pipe or four pipe systems. It can control heat only, cool only or heat & cool systems. A pipe sensor can be used for two pipe systems to verify the system is operating or automatically change to the correct operating mode. The thermostat is configurable for all unit ventilator systems. The configuration setup is used to match the thermostat to the system and turn on the features that wanted to be utilized.

### Thermostat Operation

The thermostat only has auto fan function. Auto Fan mode will automatically adjust the fan speed (Low, Medium, High) based on the set point and room temperature. The more the room temperature is from the set point the faster the fan will operate. The fan will be off in OFF mode.

### Configuration Mode

The configuration mode is used to set the thermostat to match your heating/cooling system, refer [Figure 91, p. 83](#)

To configure the thermostat perform the following steps:

1. Verify the thermostat is in the **OFF** mode. Press the **SYS** (left) button until off mode displays.
2. Press the **PROG/CONFIG** button for 5 seconds while the thermostat is in **OFF** mode.
3. Press the up or down button to change settings within each screen.
4. Press the **PROG/CONFIG** button to advance to the next screen.

**Note:** Pressing the **SYS** button will return you to the previous screen.

5. Press the **PROG/CONFIG** switch for 5 seconds to exit configuration mode.

### Configuration Mode Settings

#### 1 – System

Select the type of operation you require.

1. Heat Only is for a system with only heating.
2. Cool Only is for a system with only cooling.
3. 2-Pipe Seasonal Changeover is for a 2 pipe system that handles both heating and cooling. The thermostat selects whether the system will be set to heat or set to cool based on the pipe sensor temperature.
4. 2-Pipe Manual Changeover with Auxiliary is for a 2 pipe system that handles both heating and cooling. The user selects whether the system will be set to heat or set to cool. If set to heat and the pipe sensor indicates there is not heat, the auxiliary output will be turned on.

5. 4-Pipe Auto Changeover is for a 4 pipe system. The user selects whether the system will be set to heat, cool, heat & cool or off.

- "1" Heat only
- "2" Cool only
- "4" 2-pipe seasonal changeover

#### 2 – Temperature Scale

This thermostat can function in Fahrenheit and Celsius.

F = Fahrenheit (Default)

C = Celsius

#### 3 – Valve Type

This thermostat operates with Normally Open or Normally Closed valves. Select the correct valve type for your system.

- no = Normally Open (Default)
- nc = Normally Closed
- "5" 2-pipe seasonal changeover w auxiliary
- "6" 4-pipe manual changeover
- "7" 4-pipe auto changeover (Default)

#### 4 – Temperature Sensor

Select the type of room temperature sensor you are using.

o = On board temperature sensor (Default)

r = Remote temperature sensor

#### 6 – Pipe Sensor (Y/N) (for 2 pipe system only)

Select whether you are using a pipe sensor to monitor the pipe temperature.

n = No Pipe Sensor Connected

y = Pipe Sensor Connected (Default)

#### 7 – Pipe Sensor Cooling

Pipe temperature below this setting is considered to be cooling. If pipe sensor temperature is above this selected temperature for more than the Pipe Sensor Delay Time the cool valve will be turned off.

Changes setting between 50°F and 65°F (10.0°C and 18.0°C)  
Default: 60

#### 8 – Pipe Sensor Heating

Pipe temperature above this setting is considered to be heating. If pipe sensor temperature is below this selected temperature for more than the Pipe Sensor Delay Time the heat valve will be turned off.

Changes setting between 70°F and 90°F (21.0°C and 32.0°C)  
Default: 80

#### 9 – Pipe Sensor Delay Time

This is the time that the valve will be open to verify the pipe temperature before the valve is turned off. This gives time for circulation through the system.

Changes setting between 0 and 5 minutes at 1 minute intervals  
Default: 5

#### 10 – 1st-Stage Differential

Differential is the number of degrees between the set point temperature and the turn on temperature.

Changes setting between d1°F and d6°F (0.5°C and 3.0°C)  
Default: d1°F

### 11 – Dead Band

Dead band is the minimum number of degrees allowed between heat set point and cool set point in auto changeover operation.

Select setting between 0°F and 9°F (0.0°C and 4.5°C)  
Default: 4°F

**Note:** Only appears when system is set to 7

### 12 – Minimum Set Point Cooling (Lower Limit)

The minimum cooling set point can be limited so the cooling cannot be set too low.

Adjust setting between 45°F and 90°F (7.0°C and 32.0°C)  
Default: 45°F

**Note:** Will not appear when system is set to 1

### 13 – Maximum Set Point Heating Upper Limit

The maximum heating set point can be limited so the heating cannot be set too high.

Adjust setting between 45°F and 90°F (7.0°C and 32.0°C)  
Default: 90°F

**Note:** Will not appear when system is set to 2

### 14 – Temperature Calibration

The room temperature can be offset to display a different temperature. Example: 70F room temperature with -2 setting displays 68F.

Changes displayed room temperature between -9°F and 9°F (-4.5°C and 4.5°C) Default: 0°F

### 15 – Lock Feature

Thermostat can be locked so temperature, configurations and mode cannot be changed. Thermostat must be locked for this setting to take affect (see Lockout Feature)

0-9 - number of degrees that can be adjusted, mode cannot be changed

Cool-Heat – can adjust up to max heat and min cool but cannot change mode Default: 0

### 16 – Temperature Display

Select whether to display room temperature only, set point temperatures only or both.

“S” Display set point only

“r” Display room temperature only

“rS” Display set point and room temperature Default: “rS”

### 17 – Valve Purge

Select time to open valves during inactivity period. This feature purges the lines so water does not become stagnant and helps keeps valves from sticking.

“0” Disabled (Default)

“1” 1 minute every 24 hours

“3” 3 minutes every 24 hours

## Button Functions

Figure 91. Thermostat button



**UP** – Used to increase the set temperatures and to adjust configuration settings.

**DOWN** – Used to decrease the set temperatures and to adjust configuration settings.

**SYS** – Used to change from OFF, HEAT, COOL and AUTO changeover modes.

**CONFIG** – Used to enter configuration and advance to the next configuration screen.

**FAN** – Used to turn the fan on and off. Also used to cycle through fan speeds

**SYS then CONFIG** – Held in simultaneously for 10 seconds to lock and unlock the thermostat.

**Up and Down** – Pressed simultaneously to display pipe sensor temperature if pipe sensor is connected.


## Operating Modes

There are four possible operating modes for the thermostat. OFF, Cool, Heat, and Cool & Heat modes are accessed by pressing the SYS button.


**Note:** The modes you can access are based on your configuration.

### OFF Mode


In this mode, the thermostat will not turn on the heating or cooling devices

**Note:** The fan (when configured as continuous fan) can be turned on manually in off mode by pressing the FAN button. The word FAN shows on the display and the fan icon  appears when the fan operates.

### Heat Mode

In this mode, the thermostat controls the heating system. When the heat outputs, the flame icon  appears on the display.

### Cool Mode

In this mode, the thermostat controls the cooling system. When the cooling outputs, the snowflake icon  appears on the display.



## Start-Up

### Heat & Cool Mode

In this mode, the thermostat can automatically turn on heat or cool as needed. AUTO appears on display with heat set point and cool set point.

### Fan Mode

Only use auto fan mode. The fan speed is determined by the number of degrees the room temperature differs from the set point.

### Testing the Thermostat

Once the thermostat is configured, it should be thoroughly tested.

**Note:** *If using pipe sensors, verify pipe sensor is within range to output. Check pipe temperature by pressing the UP and DOWN buttons simultaneously.*

### Heat Test (For systems with heat)

1. Press SYS button until heat mode is displayed.
2. Adjust the set temperature so it is 5 degrees above the room temperature.
3. Heat should come on within a few seconds.
4. Adjust the set temperature 2 degrees below the room temperature and the heat should turn off. There may be a fan delay on your system.

### Cool Test (For systems with cooling)

1. Press SYS (left) button until cool mode is displayed.
2. Adjust set temperature so it is 5 degrees below room temperature.
3. Cooling should come on within a few seconds.
4. Adjust the set temperature 2 degrees above the room temperature and the cool should turn off. There may be a fan delay on your system.

### Fan Test (System off)

1. Press FAN button to toggle between Fan Off, Fan Hi, Fan Med or Fan Low.

## Tracer<sup>®</sup> ZN520 Controllers

Tracer<sup>®</sup> ZN520 controller is a discrete speed controller that can be used in a stand-alone application or can communicate with a building automation system using LonTalk Communication.

### ZN520 Stand-Alone Operation

The factory pre-programs the Tracer<sup>®</sup> ZN520 with default values to control the temperature and unit airflow. Use Tracer<sup>®</sup> Summit building automation system or Rover<sup>™</sup> software to change the default values. For more information, refer to:

- CNT-SVX04 Installation, Operation, and Maintenance manual for Tracer<sup>®</sup> ZN520

Follow the procedure below to operate the Tracer<sup>®</sup> ZN520 in a stand-alone operation:

1. Turn power on at the disconnect switch option.
2. Position the fan mode switch to either high, medium, low, or the auto position.
3. Rotate the setpoint dial on the zone sensor module to 55°F for cooling or 85°F for heating.

The appropriate control valve will actuate assuming the following conditions:

- Room temperature should be greater than 55°F and less than 85°F.
- For a 2-pipe fan-coil unit with an automatic changeover sensor, the water temperature input is appropriate for the demand placed on the unit. For example, cooling operation is requested and cold water (5° lower than room temperature) flows into the unit.
- Select the correct temperature setpoint.

**Note:** *Select and enable zone sensor temperature settings to prevent freeze damage to unit.*

### ZN520 Operation

#### Fan Mode Switch

**Off** - Fan is turned off, two-position damper option spring-returns closed.

**Hi, Med, Lo** - Fan runs continuously at the selected speed. The two-position damper option opens to an adjustable mechanical stop position.

#### Controller

**Off** - Fan is off; control valves and fresh air damper option close. Low air temperature detection option is still active.

**Auto** - Fan speed control in the auto setting allows the modulating (3-wire floating point) or 2-position control valve option and three-speed fan to work cooperatively to meet precise capacity requirement, while minimizing fan speed (motor/energy/acoustics) and valve position (pump energy, chilled water reset). As the capacity requirement increases at low fan speed, the water valve opens. When the low fan speed capacity switch point is reached, the fan switches to medium speed and the water valve repositions to maintain an equivalent capacity. The reverse sequence takes place with a decrease in required capacity.

**Low/Med/High (Continuous Fan)** - Fan operates continuously while control valve option cycles to maintain setpoint temperature.

### Sequence of Operation

#### Occupancy Modes

The controller operates the fan in the following modes:

- Occupied
- Unoccupied
- Occupied standby

- Occupied bypass
- Tracer<sup>®</sup> Summit with supply fan control

## Occupied

When the controller is in the occupied mode, the unit attempts to maintain the space temperature at the active occupied heating or cooling setpoint, based on the measured space temperature, the discharge air temperature, the active setpoint, and the proportional/integral control algorithm. The modulating control algorithm used when occupied or in occupied standby is described in the following sections. Additional information related to the handling of the controller setpoints can be found in the previous Setpoint operation section.

## Unoccupied Mode

When the controller is in the unoccupied mode, the controller attempts to maintain the space temperature at the stored unoccupied heating or cooling setpoint, based on the measured space temperature, the active setpoint and the control algorithm, regardless of the presence of a hard-wired or communicated setpoint. Similar to other configuration properties of the controller, the locally stored unoccupied setpoints can be modified using Rover service tool.

In unoccupied mode, a simplified zone control algorithm is run. During the cooling mode, when the space temperature is above the cool setpoint, the primary cooling capacity operates at 100 percent. If more capacity is needed, the supplementary cooling capacity turns on (or opens to 100 percent). During the heating mode, when the space temperature is below the heat setpoint, the primary heating capacity turns on. All capacity is turned off when the space temperature is between the unoccupied cooling and heating setpoints. Note that primary heating or cooling capacity is defined by unit type and whether heating or cooling is enabled or disabled. For example, if the economizer is enabled and possible, it will be the primary cooling capacity. If hydronic heating is possible, it will be the primary heating capacity.

## Occupied Standby Mode

The controller can be placed into the occupied standby mode when a communicated occupancy request is combined with the local (hard-wired) occupancy binary input signal. When the communicated occupancy request is unoccupied, the occupancy binary input (if present) does not affect the controller's occupancy. When the communicated occupancy request is occupied, the controller uses the local occupancy binary input to switch between the occupied and occupied standby modes.

During occupied standby mode, the controller's economizer damper position goes to the economizer standby minimum position. The economizer standby minimum position can be changed using Rover service tool.

In the occupied standby mode, the controller uses the occupied standby cooling and heating setpoints. Because the occupied standby setpoints typically cover a wider range than the occupied setpoints, the Tracer<sup>®</sup> ZN520 controller reduces the demand for heating and cooling the space. Also, the outdoor air economizer damper uses the economizer standby minimum position to reduce the heating and cooling demands.

When no occupancy request is communicated, the occupancy binary input switches the controller's operating mode between occupied and unoccupied. When no communicated occupancy request exists, the unit cannot switch to occupied standby mode.

## Occupied Bypass Mode

The controller can be placed in occupied bypass mode by either communicating an occupancy request of Bypass to the controller or by using the timed override On button on the Trane zone sensor.

When the controller is in unoccupied mode, you can press the On button on the zone sensor to place the controller into occupied bypass mode for the duration of the bypass time (typically 120 minutes).

**Occupancy Sources.** There are four ways to control the controller's occupancy:

- Communicated request (usually provided by the building automation system or peer device)
- By pressing the zone sensor's timed override On button
- Occupancy binary input
- Default operation of the controller (occupied mode)

A communicated request from a building automation system or another peer controller can change the controller's occupancy. However, if communication is lost, the controller reverts to the default operating mode (occupied) after 15 minutes (configurable, specified by the "receive heartbeat time"), if no local hard-wired occupancy signal exists.

A communicated request can be provided to control the occupancy of the controller. Typically, the occupancy of the controller is determined by using time-of-day scheduling of the building automation system. The result of the time-of-day schedule can then be communicated to the unit controller.

## Tracer<sup>®</sup> Summit with Supply Fan Control

If the unit is communicating with Tracer<sup>®</sup> Summit and the supply fan control programming point is configured for Tracer<sup>®</sup> (the factory configures as local), Tracer<sup>®</sup> Summit will control the fan regardless of the fan mode switch position.

When the fan mode switch is set to Off or when power is restored to the unit, all lockouts (latching diagnostics) are manually reset. The last diagnostic to occur is retained until the unit power is disconnected.



## Start-Up

---

For specific instructions regarding Tracer® ZN520 Controller, refer to:

CNT-SVX04A-EN Tracer® ZN520 Unit Controller Installation, Operation and Programming Guide

### Cooling Operation

The heating and cooling setpoint high and low limits are always applied to the occupied and occupied standby setpoints. During the cooling mode, the controller attempts to maintain the space temperature at the active cooling setpoint. Based on the controller's occupancy mode, the active cooling setpoint is one of the following:

- Occupied cooling setpoint
- Occupied standby cooling setpoint
- Unoccupied cooling setpoint

The controller uses the measured space temperature, the active cooling setpoint, and discharge air temperature along with the control algorithm to determine the requested cooling capacity of the unit (0 percent–100 percent). The outputs are controlled based on the unit configuration and the required cooling capacity. To maintain space temperature control, the cooling outputs (modulating hydronic valve, two-position hydronic valve, or outdoor air economizer damper) are controlled based on the cooling capacity output.

The cooling output is controlled based on the cooling capacity. At 0 percent capacity, all cooling capacities are off and the damper is at minimum position. Between 0 percent and 100 percent capacity, the cooling outputs are controlled according to modulating valve logic (modulating valves) or cycled on (2-position valves). As the load increases, modulating outputs open further and binary outputs are energized longer. At 100 percent capacity, the cooling valve or damper is fully open (modulating valves) or on continuously (and 2-position valves).

Unit diagnostics can affect fan operation, causing occupied and occupied standby fan operation to be defined as abnormal. Refer to [“Diagnostics and Troubleshooting,” p. 108](#) for more information about abnormal fan operation.

The controller operates the supply fan continuously when the controller is in the occupied and occupied standby modes, for either heating or cooling. The controller only cycles the fan off with heating and cooling capacity in the unoccupied mode.

The economizer is used for cooling purposes whenever the outdoor temperature is below the economizer enable setpoint and there is a need for cooling. The economizer is used first to meet the space demand, and other forms of cooling are used if the economizer cannot meet the demand alone. See modulating outdoor air damper operation for additional information.

Cascade cooling control initiates a discharge air tempering function if the discharge air temperature falls below the

discharge air temperature control low limit, all cooling capacity is at minimum, and the discharge control loop determines a need to raise the discharge air temperature. The controller then provides heating capacity to raise the discharge air temperature to its low limit.

### Discharge Air Tempering

The discharge air tempering function enables when cold outdoor air is brought in through the outdoor air damper, causing the discharge air to fall below the discharge air temperature control low limit. The controller exits the discharge air tempering function when heat capacity has been at zero percent for five minutes.

### Heating Operation

During heating mode, the controller attempts to maintain the space temperature at the active heating setpoint. Based on the occupancy mode of the controller, the active heating setpoint is one of the following:

- Occupied heating
- Occupied standby heating
- Unoccupied heating

During dehumidification in the heating mode, the controller adjusts the heating setpoint up to the cooling setpoint. This reduces the relative humidity in the space with a minimum of energy usage.

The controller uses the measured space temperature, the active heating setpoint, and discharge air temperature, along with the control algorithm, to determine the requested heating capacity of the unit (0 percent–100 percent). The outputs are controlled based on the unit configuration and the required heating capacity.

Unit diagnostics can affect the controller operation, causing unit operation to be defined as abnormal. Refer to [“Diagnostics and Troubleshooting,” p. 108](#) for more information about abnormal unit operation.

The heating output is controlled based on the heating capacity. At 0 percent capacity, the heating output is off continuously. Between 0 percent and 100 percent capacity, the heating output is controlled according to modulating valve logic (3-wire modulating valves) or cycled on (two-position valves). As the load increases, modulating outputs open further and binary outputs are energized longer. At 100 percent capacity, the heating valve is fully open (3-wire modulating valves) or on continuously (two-position valves).

The fan output(s) normally run continuously during the occupied and occupied standby modes, but cycle between high and off speeds with heating/cooling during the unoccupied mode. When in the occupied mode or occupied standby mode and the fan speed is set at the high, medium, or low position, the fan runs continuously at the selected speed. Refer to the Troubleshooting section for more information on abnormal fan operation.

When the unit's supply fan is set to auto, the controller's configuration determines the fan speed when in the

occupied mode or occupied standby mode. The fan runs continuously at the configured heating fan speed or cooling fan speed. For all fan speed selections except off, the fan cycles off during unoccupied mode.

The economizer outdoor air damper is never used as a source of heating. Instead, the economizer damper (when present) is only used for ventilation; therefore, the damper is at the occupied minimum position in the occupied mode. The damper control is primarily associated with occupied fan operation.

## Fan Mode Operation

For multiple fan speed applications, the controller offers additional fan configuration flexibility. Separate default fan speeds for heating and cooling modes can be configured. The fan runs continuously for requested speeds (off, high, medium, or low). When the fan mode switch is in the Auto position or a hard-wired fan mode input does not exist, the fan operates at the default configured speed. See the following table for default fan configuration for heat and cool mode. During unoccupied mode, the fan cycles between high speed and off with heating and cooling fan modes. If the requested speed is off, the fan always remains off.

**Table 32. Fan configuration for Tracer® ZN520 units**

Auto Fan Operation		Fan Speed Default
Heating	Continuous	Off
		Low
		Medium
		High
Cooling	Continuous	Off
		Low
		Medium
		High

During dehumidification, when the fan is on Auto, the fan speed can switch depending on the error. Fan speed increases as the space temperature rises above the active cooling setpoint.

Additional flexibility built into the controller allows you to enable or disable the local fan switch input. The fan mode request can be either hard-wired or communicated to the controller. When both are present, the communicated request has priority over the hard-wired input. See the following tables.

**Table 33. Local fan switch enabled**

Communicated Fan Speed Input	Fan Switch (Local)	Fan Operation
Off	Ignored	Off
Low	Ignored	Low
Medium	Ignored	Medium
High	Ignored	High
Auto	Off	Off
Low		
Medium		
High		
Auto	Off	Off
Low		
Medium		
High		

**Note:** Auto (configured default, determined by heat/cool mode)

**Table 34. Fan operation in heating and cooling modes**

Fan Mode	Heating		Cooling	
	Occupied	Unoccupied	Occupied	Unoccupied
Off	Off	Off	Off	Off
Low	Low	Off/high	Low	Off/high
Medium	Med	Off/high	Med	Off/high
High	High	Off/high	High	Off/high
Auto	Default fan speed	Off/high	Default fan speed	Off/high

**Table 35. Local fan switch disabled or not present**

Communicated Fan Speed Input	Fan Operation
Off	Off
Low	Low
Medium	Medium
High	High
Auto (or not present)	Auto (fan runs at the default speed)

## Continuous Fan Operation

During occupied and occupied standby modes, the fan normally is on. For multiple speed fan applications, the fan normally operates at the selected or default speed (off, high, medium, or low). When fan mode is auto, the fan operates at the default fan speed.

During unoccupied mode, the controller controls the fan off. While unoccupied, the controller heats and cools to maintain the unoccupied heating and cooling setpoints. In unoccupied mode, the fan is controlled on high speed only with heating or cooling.

The unit fan is always off during occupied, occupied standby, and unoccupied modes when the unit is off due to a diagnostic or when the unit is in the off mode due to the local zone sensor module, a communicated request, or the default fan speed (off).

If both a zone sensor module and communicated request exist, the communicated request has priority.

## Fan Cycling Operation

**Tracer® ZN520 does not support fan cycling in occupied mode.** The fan cycles between high speed and off in the unoccupied mode only. The controller's cascade control algorithm requires continuous fan operation in the occupied mode.

## Fan Off Delay

When a heating output is controlled off, the controller automatically holds the fan on for an additional 30 seconds. This 30-second delay gives the fan time to blow off any residual heat from the heating source, such as a steam coil. When the unit is heating, the fan off delay is normally applied to control the fan; otherwise, the fan off delay does not apply.

## Water Temperature Sampling Function

Only units using the main hydronic coil for both heating and cooling (2-pipe changeover and 4-pipe changeover units) use the entering water temperature sampling



## Start-Up

function. Two-pipe changeover and 4-pipe changeover applications allow the main coil to be used for heating and for cooling; therefore, these applications require an entering water temperature sensor.

When three-way valves are ordered with a Tracer<sup>®</sup> ZN520 controller, the controller is factory-configured to disable the entering water temperature sampling function, and the entering water sensor is mounted in the proper location. Disabling entering water temperature sampling eliminates unnecessary water flow through the main coil when three-way valves are used.

The controller invokes entering water temperature sampling only when the measured entering water temperature is too cool to heat or too warm to cool. Entering water is cold enough to cool when it is five degrees below the measured space temperature. Entering water is warm enough to heat when it is five degrees above the measured space temperature.

When the controller invokes the entering water temperature sampling function, the unit opens the main hydronic valve for no more than three minutes before considering the measured entering water temperature. An initial stabilization period is allowed to flush the coil. This period is equal to 30 seconds plus half of the valve stroke time. Once this temperature stabilization period has expired, the controller compares the entering water temperature against the effective space temperature (either hard-wired or communicated) to determine whether the entering water can be used for the desired heating or cooling. If the water temperature is not usable for the desired mode, the controller continues to compare the entering water temperature against the effective space temperature for a maximum of three minutes.

The controller automatically disables the entering water temperature sampling and closes the main hydronic valve when the measured entering water exceeds the high entering water temperature limit (110°F). When the entering water temperature is warmer than 110°F, the controller assumes the entering water temperature is hot because it is unlikely the coil would drift to a high

temperature unless the actual loop temperature was very high.

If the entering water temperature is unusable—too cool to heat or too warm to cool—the controller closes the hydronic valve and waits 60 minutes before initializing another sampling. If the controller determines the entering water temperature is valid for heating or cooling, it resumes normal heating/cooling control and effectively disables entering water temperature sampling until it is required.

### Electric Heat Operation

Tracer<sup>®</sup> controllers support 1-stage electric heat. Also, Tracer<sup>®</sup> ZN520 and UC400-B support 2-stage electric heat. Tracer<sup>®</sup> ZN520 and UC400-B cycle the electric heat to control the discharge air temperature. The rate of cycling is dependent upon the load in the space and the temperature of the incoming fresh air from the economizer (if any). Two-pipe changeover units with electric heat use the electric heat only when hot water is not available.

### Economizer Damper

#### Tracer<sup>®</sup> ZN520 and UC400-B only

With a valid outdoor air temperature (either hard-wired or communicated), Tracer<sup>®</sup> ZN520 and UC400-B use the modulating economizer damper as the highest priority cooling source. Economizer operation is only possible using a modulating damper during the occupied, occupied standby, unoccupied, and occupied bypass modes.

The controller initiates the economizer function if the fresh air temperature is cold enough for use as free cooling capacity. If the fresh air temperature is less than the economizer enable setpoint (absolute dry bulb), the controller modulates the fresh air damper (between the active minimum damper position and 100 percent) to control the amount of fresh air cooling capacity. When the fresh air temperature rises 5°F above the economizer enable point, the controller disables economizing and moves the fresh air damper back to its predetermined minimum position based on the current occupancy mode or communicated minimum damper position.

**Table 36. Relationship between outdoor temperature sensors and economizer damper position (Tracer<sup>®</sup> ZN520 and UC400-B controllers only)**

Outdoor Air Temperature	Modulating Fresh Air Damper Occupied or Occupied Bypass	Occupied Standby	Unoccupied
None or invalid	Open to occupied minimum position	Open to occupied standby minimum position	Closed
Failed	Open to occupied minimum position	Open to occupied standby	Closed
Present and economizer feasible	Economizing: minimum position to 100%	Economizing: between occupied standby minimum position to 100%	Open and economizing only when unit operating, closed otherwise
Present and economizer not feasible	Open to occupied minimum position	Open to occupied standby minimum position	Closed

### Dehumidification

Dehumidification is possible when mechanical cooling is available, the heating capacity is located in the reheat position, and the space relative humidity setpoint is

valid. The controller starts dehumidifying the space when the space humidity exceeds the humidity setpoint.

The controller continues to dehumidify until the sensed humidity falls below the setpoint minus the relative humidity offset. The controller uses the cooling and reheat

capacities simultaneously to dehumidify the space. While dehumidifying, the discharge air temperature is controlled to maintain the space temperature at the current setpoint.

A typical scenario involves high humidity and high temperature load of the space. The controller sets the cooling capacity to 100 percent and uses the reheat capacity to warm the discharge air to maintain space temperature control. Dehumidification may be disabled via Tracer® or configuration.

**Note:** *If the unit is in the unoccupied mode, the dehumidification routine will not operate.*

## Data Sharing

Because this controller utilizes LONWORKS® technology, the controller can send or receive data (setpoint, heat/cool mode, fan request, space temperature, etc.) to and from other controllers on the communication link, with or without the existence of a building automation system. This applies to applications where multiple unit controllers share a single space temperature sensor (for rooms with multiple units but only one zone sensor) for both standalone (with communication wiring between units) and building automation system applications. For this application you will need to use the Rover service tool.

For more information on setup, refer to:

- *EMTX-SVX01 Rover Service Tool Installation, Operation, and Programming manual.*

## Binary Inputs

Tracer® ZN520 controller has four available binary inputs. Normally, these inputs are factory-configured for the following functions:

- Binary input 1: Low temperature detection (freezestat)
- Binary input 2: Condensate overflow
- Binary input 3: Occupancy/ Generic
- Binary input 4: Fan status

**Note:** *The generic binary input can be used with a Tracer® Summit building automation system only.*

Each binary input default configuration (including normally open/closed) is set at the factory. See the following table. However, you can configure each of the four binary inputs as normally open or normally closed. The controller will be set properly for each factory-supplied binary input end-device. When no device is connected to the input, configure the controller's input as not used.

**Table 37. Binary input configurations**

Binary Input	Description	Configuration	Controller Operation	
			Contact Closed	Contact Open
BI 1	Low temperature detection <sup>(a)</sup>	Normally closed	Normal	Diagnostic <sup>(b)</sup>
BI 2	Condensate overflow <sup>(a)</sup>	Normally closed	Normal	Diagnostic <sup>(b)</sup>
BI 3	Occupancy	Normally open	Unoccupied	Occupied
BI 3	Generic binary input	Normally open	Normal <sup>(c)</sup>	Normal <sup>(c)</sup>
BI 4	Fan status <sup>(a)</sup>	Normally open	Normal	Diagnostic <sup>(d)</sup>

**Note:** The occupancy binary input is for standalone unit controllers as an occupied/unoccupied input. However, when the controller receives a communicated occupied/unoccupied request, the communicated request has priority over the hard-wired input.

- (a) During low temperature, condensate overflow, and fan status diagnostics, the controller disables all normal unit operation of the fan, valves, and damper.  
 (b) [Table 38](#) shows the controller's response to low temperature detection, condensate overflow, and fan status diagnostics.  
 (c) The generic binary input does not affect unit operation. A building automation system reads this input as a generic binary input.  
 (d) If the fan mode input is in the off position or the controller is in the unoccupied mode with the fan off, the fan status input will be open. A diagnostic will not be generated when the controller commands the fan off. A diagnostic will only be generated if the fan status input does not close after one minute from energizing a fan output or any time the input is open for one minute. The controller waits up to one minute after energizing a fan output to allow the differential pressure to build up across the fan.



## Start-Up

### Binary Outputs

Binary outputs are configured to support the following (see the following table):

- Three fan stages (when one or two fan stages are present, medium fan speed can be configured as exhaust fan)
- One hydronic cooling stage

- One hydronic heating stage (dehumidification requires this to be in the reheat position)
- One DX cooling stage
- One or two-stage electric heat (dehumidification requires this to be in the reheat position)
- Face and bypass damper
- Modulating outdoor air damper
- One baseboard heat stage

**Table 38. Binary output configuration (Tracer® ZN520)**

Binary Output	Configuration
J1-1	Fan high
J1-2	Fan medium
J1-3	Fan low
J1-4	(Key)
J1-5	Cool valve—open, or 2-position valve <sup>(a)</sup>
J1-6	Cool valve—close Note 1
J1-9	Heat valve—open, or 2 position valve, or 1st electric heat stage <sup>(a)</sup>
J1-10	Heat valve—close or 2nd Electric heat stage <sup>(a)</sup>
J1-11	Fresh air damper—open
J1-12	Fresh air damper—close
TB4-1	Generic/baseboard heat output
TB4-2	24 Vac

(a) For Tracer® ZN520 units configured and applied as 2-pipe hydronic heat/cool changeover, terminals J1-5 and J1-6 are used to control the primary valve for both heating and cooling. For Tracer® ZN520 units configured and applied as 2-pipe hydronic heat/cool changeover with electric heat, terminals J1-5 and J1-6 are used to control the primary valve (for both cooling and heating), and terminals J1-9 and J1-10 are used only for the electric heat stage. For those 2-pipe changeover units, electric heat will not be energized while the hydronic supply is hot (5° or more above the space temperature).

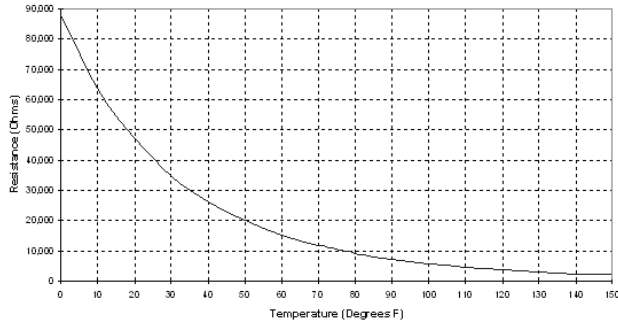
**Table 39. Analog inputs (Tracer® ZN520)**

Description	Terminals	Function	Range
Zone	TB3-1	Space temperature input	5°F to 122°F
Ground	TB3-2	Analog ground	n/a
Set	TB3-3	Setpoint input	40°F to 115°F
Fan	B3-4	Fan switch input	4821 to 4919 W (off)
			2297 to 2342 W (auto)
			10593 to 10807 W (low)
			13177 to 13443 W (medium)
			15137 to 16463 W (high)
Ground	TB3-6	Analog ground	n/a
Analog input 1	J3-1	Entering water temperature	-40°F to 212°F
		Analog ground	n/a
Analog input 2	J3-3	Discharge air temperature	-40°F to 212°F
		Analog ground	n/a
Analog input 3	J3-5	Fresh air temp/generic temp	-40°F to 212°F
		Analog ground	n/a
Analog input 4	J3-7	Universal input	0% to 100%
		Generic 4–20mA	0% to 100%
		Humidity	0 to 2000 ppm
		CO <sub>2</sub>	
	J3-8	Analog ground	n/a
Ground	J3-9	Analog ground	n/a

**Notes:** - Wall-mounted sensors include a thermistor soldered to the sensor's circuit board  
 - Unit mounted sensors include a return air sensor in the unit's return air stream.  
 Changeover units include an entering water temperature sensor.

The zone sensor, entering water temperature sensor, and the discharge air sensor, and the outside air temperature sensor are 10 KΩ thermistors. See the following figure for the resistance-temperature curve for these thermistors.

**Figure 92. Resistance temperature curve for the zone sensor, entering water temperature sensor, and discharge air sensor**



## Zone Sensor

The controller accepts the following zone sensor module inputs:

- Space temperature measurement (10kΩ thermistor)
- Local setpoint (either internal or external on the zone sensor module)
- Fan switch
- Timed override (On) and Cancel timed override
- Communication jack

**Table 40. Zone Sensor Thermistor Curve (Resistance in Ohms)**

°C	°F	R	°C	°F	R	°C	°F	R	°C	°F	R
0	32	32885	25	77	10004	50	122	3759	75	167	1484
1	33.8	31238	26	78.8	9557	1	123.8	3597	76	168.8	1436
2	35.6	29684	27	80.6	9135	2	125.6	3445	77	170.6	1389
3	37.4	28216	28	82.4	8737	3	127.4	3301	78	172.4	1345
4	39.2	26830	29	84.2	8362	4	129.2	3165	79	174.2	1302
5	41	25520	30	86	8007	5	131	3037	80	176	1260
6	42.8	24282	31	87.8	7672	6	132.8	2915	81	177.8	1220
7	44.6	23112	32	89.6	7355	7	134.6	2800	82	179.6	1182
8	46.4	22005	33	91.4	7056	8	136.4	2691	83	181.4	1145
9	48.2	20957	34	93.2	6772	9	138.2	2588	84	183.2	1109
10	50	19966	35	95	6503	10	140	2490	85	185	1074
11	51.8	19028	36	96.8	6248	11	141.8	2397	86	186.8	1041
12	53.6	18139	37	98.6	6006	12	143.6	2309	87	188.6	1009
13	55.4	17297	38	100.4	5777	13	145.4	2225	88	190.4	978
14	57.2	16499	39	102.2	5559	14	147.2	2145	89	192.2	948
15	59	15743	40	104	5352	15	149	2070	90	194	920
16	60.8	15025	41	105.8	5156	16	150.8	1998	91	195.8	892
17	62.6	14345	42	107.6	4969	17	152.6	1929	92	197.6	865
18	64.4	13700	43	109.4	4791	18	154.4	1864	93	199.4	839
19	66.2	13087	44	111.2	4621	19	156.2	1802	94	201.2	814
20	68	12505	45	113	4460	20	158	1742	95	203	790
21	69.8	11953	46	114.8	4306	21	159.8	1686	96	204.8	767
22	71.6	11428	47	116.6	4160	22	161.6	1632	97	206.6	744
23	73.4	10929	48	118.4	4020	23	163.4	1580	98	208.4	722
24	75.2	10455	49	120.2	3886	24	165.2	1531	99	210.2	701

## Space Temperature Measurement

Trane zone sensors use a 10kΩ thermistor to measure the space temperature. Typically, zone sensors are wall-mounted in the room and include a space temperature thermistor. As an option, the zone sensor can be unit-

mounted with a separate space temperature thermistor located in the unit's return air stream. If both a hard-wired and communicated space temperature value exist, the controller ignores the hard-wired space temperature input and uses the communicated value.



## Start-Up

### External Setpoint Adjustment

Zone sensors with an external setpoint adjustment (1kΩ) provide the controller with a local setpoint (50°F to 85°F or 10°C to 29.4°C). The external setpoint is exposed on the zone sensor’s front cover.

When the hard-wired setpoint adjustment is used to determine the setpoints, all unit setpoints are calculated based on the hard-wired setpoint value, the configured setpoints, and the active mode of the controller. The hard-wired setpoint is used with the controller’s occupancy mode (occupied, occupied standby, or unoccupied), the heating or cooling mode, the temperature deadband values, and the heating and cooling setpoints (high and low limits) to determine the controller’s active setpoint.

When a building automation system or other controller communicates a setpoint to the controller, the controller ignores the hard-wired setpoint input and uses the communicated value. The exception is the unoccupied mode, when the controller always uses the stored default unoccupied setpoints. After the controller completes all setpoint calculations, based on the requested setpoint, the occupancy mode, the heating and cooling mode, and other factors, the calculated setpoint is validated against the following setpoint limits:

- Heating setpoint high limit
- Heating setpoint low limit
- Cooling setpoint high limit
- Cooling setpoint low limit

These setpoint limits only apply to the occupied and occupied standby heating and cooling setpoints. These setpoint limits do not apply to the unoccupied heating and cooling setpoints stored in the controller’s configuration.

When the controller is in unoccupied mode, it always uses the stored unoccupied heating and cooling setpoints. The unit can also be configured to enable or disable the local (hard-wired) setpoint. This parameter provides additional flexibility to allow you to apply communicated, hard-wired, or default setpoints without making physical changes to the unit.

Similar to hard-wired setpoints, the effective setpoint value for a communicated setpoint is determined based on the stored default setpoints (which determines the occupied and occupied standby temperature deadbands) and the controller’s occupancy mode.

### Fan Switch

The zone sensor fan switch provides the controller with an occupied (and occupied standby) fan request signal (Off, Low, Medium, High, Auto). If the fan control request is communicated to the controller, the controller ignores the hard-wired fan switch input and uses the communicated value. The zone sensor fan switch input can be enabled or disabled through configuration using the Rover service tool. If the zone sensor switch is disabled, the controller resorts to its stored configuration default fan speeds for

heating and cooling, unless the controller receives a communicated fan input.

When the fan switch is in the off position, the controller does not control any unit capacity. The unit remains powered and all outputs drive to the closed position. Upon a loss of signal on the fan speed input, the controller reports a diagnostic and reverts to using the default fan speed.

### On/Cancel Buttons

Momentarily pressing the on button during unoccupied mode places the controller in occupied bypass mode for 120 minutes. You can adjust the number of minutes in the unit controller configuration using Rover service tool. The controller remains in occupied bypass mode until the override time expires or until you press the Cancel button.

### Communication Jack

Use the RJ-11 communication as the connection point from Rover service tool to the communication link—when the communication jack is wired to the communication link at the controller. By accessing the communication jack via Rover, you can access any controller on the link.

### Communications

The controller communicates via LonTalk protocol. Typically, a communication link is applied between unit controllers and a building automation system. Communication also is possible via Rover, Trane’s service tool. Peer-to-peer communication across controllers is possible even when a building automation system is not present. You do not need to observe polarity for LonTalk communication links.

The controller provides six 0.25-inch quick-connect terminals for the LonTalk communication link connections, as follows:

- Two terminals for communication to the board
- Two terminals for communication from the board to the next unit (daisy chain)
- Two terminals for a connection from the zone sensor back to the controller

**Table 41. Zone sensor wiring connections**

TB1	Description
1	Space temperature / timed override detection
2	Common
3	Setpoint
4	Fan mode
5	Communications
6	Communications

## Tracer® UC400-B Controller

Tracer® UC400-B controller delivers single zone VAV control in a stand-alone operation or as part of a building automation system using BACnet® communications.

### UC400-B Stand-Alone Operation

The factory pre-programs the Tracer® UC400-B with default values to control the temperature and unit airflow. Use Tracer® SC building automation system or Tracer® TU software to change the default values. For more information, refer to:

- BAS-SVX48 Tracer® UC400-B Programmable Controller for Blower Coil, Fan Coil, and Unit Ventilator Installation, Operation, and Programming Guide

Follow the procedure below to operate the Tracer® UC400-B in a stand-alone operation:

1. Turn power on at the disconnect switch option.
2. Position the fan mode switch to either high, medium, low, or the auto position.
3. Rotate the setpoint dial on the zone sensor module to 55°F for cooling or 85°F for heating.

The appropriate control valve will actuate assuming the following conditions:

- Room temperature should be greater than 55°F and less than 85°F.
- For a 2-pipe fan-coil unit with an automatic changeover sensor, the water temperature input is appropriate for the demand placed on the unit. For example, cooling operation is requested and cold water (5° lower than room temperature) flows into the unit.
- Select the correct temperature setpoint.

**Note:** Select and enable zone sensor temperature settings to prevent freeze damage to unit.

### UC400-B Operation

#### Controller

**Off** - Fan is off; control valves and fresh air damper option close. Low air temperature detection option is still active.

**Auto** - Fan speed control in the auto setting allows the modulating (3-wire floating point) or 2-position control valve option and 1-, 2-, 3- or variable-speed fan to work cooperatively to meet precise capacity requirement, while minimizing fan speed (motor/energy/acoustics) and valve position (pump energy, chilled water reset). As the capacity requirement increases, the water valve opens. When the fan speed capacity switch points are reached, the fan speed ramps up and the water valve repositions to maintain an equivalent capacity. The reverse sequence takes place with a decrease in required capacity.

**Low/Med/High** - The fan runs continuously at the selected speed and the valve option will cycle to meet setpoint.

## Sequence of Operation

### Power-Up Sequence

When 24 Vac power is initially applied to the controller, the following sequence occurs:

1. The Power Marquee LED turns on as red, then flashes green, and then turns a solid green.
2. All outputs are controlled **OFF** and all modulating valves and dampers close.
3. The controller reads all input local values to determine initial values.
4. The random start timer begins.
5. The random start timer expires.
6. Normal operation begins, assuming there are no generated diagnostics. If any points are in fault or alarm mode, the Power Marquee LED flashes red.

**Important:** Flashing red does not indicate that the controller will fail to operate. Instead, the point(s) that are in fault or alarm mode should be checked to determine if the status of the point(s) is acceptable to allow equipment operation.

### Random Start

Random start is intended to prevent all units in a building from energizing at the same time. The random start timer delays the fan and any heating or cooling start-up from 5 to 30 seconds.

### Occupancy Modes

Occupancy modes can be controlled in the following ways:

- The state of the local (hard wired) occupancy binary input BI1.
- A timed override request from a Trane zone sensor.
- A communicated signal from either a Tracer® SC or BAS.

A communicated request, from either a Tracer® SC or BAS, takes precedence over local requests. If a communicated occupancy request has been established, and is no longer present, the controller reverts to the default (occupied) occupancy mode after 15 minutes (if no hard wired occupancy request exists). The controller has the following occupancy modes:

- Occupied
- Unoccupied
- Occupied standby
- Occupied bypass

### Occupied Mode

In Occupied Mode, the controller maintains the space temperature based on the occupied space temperature setpoint ± occupied offset. The controller uses the occupied mode as a default mode when other forms of

occupancy request are not present and the fan runs continuously. The outdoor air damper, if present, will close when the fan is OFF. The temperature setpoints can be local (hard wired), communicated, or stored default values (configurable using the Tracer<sup>®</sup> TU service tool).

### Unoccupied Mode

In unoccupied mode, the controller attempts to maintain the space temperature based on the unoccupied heating or cooling setpoint. The fan will cycle between high speed and **OFF**. In addition, the outdoor air damper remains closed, unless economizing. The controller always uses the stored default setpoint values (configurable using the Tracer<sup>®</sup> TU service tool), regardless of the presence of a hard wired or communicated setpoint value.

### Occupied Standby Mode

The controller is placed in occupied standby mode *only* when a communicated occupied request is combined with an unoccupied request from occupancy binary input BI1. In occupied standby mode, the controller maintains the space temperature based on the occupied standby heating or cooling setpoints. Because the occupied standby setpoints have a typical temperature spread of 2°F (1.1°C) in either direction, and the outdoor air damper is closed, occupied standby mode reduces the demand for heating and cooling the space. The fan will run as configured (continuously) for occupied mode. The controller always uses the stored default setpoint values (configurable using the Tracer<sup>®</sup> TU service tool), regardless of hard wired or communicated setpoint values. In addition, the outdoor air damper uses the economizer occupied standby minimum position setpoint to reduce the ventilation rate.

### Occupied Bypass Mode

The controller is placed in occupied bypass mode when the controller is operating in the unoccupied mode and when either the timed override **ON** button on the Trane zone sensor is pressed or the controller receives a communicated occupied bypass signal from a BAS. In occupied bypass mode, the controller maintains the space temperature based on the occupied heating or cooling setpoints. The fan will run as configured (continuous or cycling). The outdoor air damper closes when the fan is **OFF**. The controller remains in occupied bypass mode until either the **CANCEL** button is pressed on the Trane zone sensor or the occupied bypass time (configurable using the Tracer<sup>®</sup> TU service tool) expires. The temperature setpoints can be configured as local (hard wired), communicated, or stored default values using the Tracer<sup>®</sup> TU service tool.

### Timed Override Control

If the controller has a timed override option (ON/CANCEL buttons), pushing the ON button initiates a timed override on request. A timed override on request changes the occupancy mode from unoccupied mode to occupied bypass mode. In occupied bypass mode, the controller controls the space temperature based on the occupied

heating or cooling setpoints. The occupied bypass time, which resides in the controller and defines the duration of the override, is configurable from 0 to 240 minutes (default value of 120 minutes). When the occupied bypass time expires, the unit transitions from occupied bypass mode to unoccupied mode. Pushing the **CANCEL** button cancels the timed override request. In addition, it will end the timed override before the occupied bypass time has expired and transition the unit from occupied bypass mode to unoccupied mode.

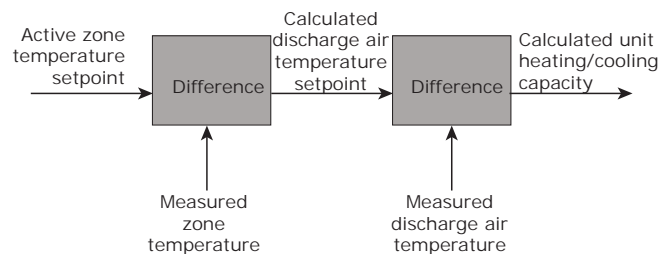
If the controller is in any mode other than unoccupied mode when the **ON** button is pressed, the controller still starts the occupied bypass timer without changing to occupied bypass mode. If the controller is placed in unoccupied mode before the occupied bypass timer expires, the controller is placed into occupied bypass mode and remains in this mode until either the **CANCEL** button is pressed on the Trane zone sensor or the occupied bypass time expires.

### Zone Temperature Control

The controller has three methods of zone temperature control:

- **Cascade zone control**—used in the occupied, occupied bypass, and occupied standby modes. It maintains zone temperature by controlling the discharge air temperature to control the zone temperature. The controller uses the difference between the measured zone temperature and the active zone temperature setpoint to produce a discharge air temperature setpoint. The controller compares the discharge air temperature setpoint with the discharge air temperature and calculates a unit heating/cooling capacity accordingly (refer to the illustration below). The end devices (outdoor air damper, valves, and so on) operate in sequence based on the unit heating/cooling capacity (0–100 percent).

**Figure 93. Cascade zone control**



If the discharge air temperature falls below the discharge air temperature low limit setpoint, (configurable using the Tracer<sup>®</sup> TU service tool), and the cooling capacity is at a minimum, the available heating capacity is used to raise the discharge air temperature to the low limit.

- **Simplified zone control**— if discharge air temperature failure occurs, then simplified zone

controls runs. In the unoccupied mode, the controller maintains the zone temperature by calculating the required heating or cooling capacity (0–100%) according to the measured zone temperature and the active zone temperature setpoint. The active zone temperature setpoint is determined by the current operating modes, which include occupancy and heat/cool modes.

- **Discharge air temperature control**— is the backup mode that runs *only* if there is not valid zone temperature. In this mode, the active space temperature setpoint is used as the discharge air temperature setpoint.

**Important:** *This is not a normal operating mode. The source of the invalid zone temperature needs to be corrected to restore normal operation.*

## Discharge Air Tempering

If the controller is in cooling mode, cascade zone control initiates a discharge air tempering function when:

- The discharge air temperature falls below the discharge air temperature low limit setpoint (configurable using the Tracer® TU service tool)
- All cooling capacity is at a minimum. The discharge air tempering function allows the controller to provide heating capacity (if available) to raise the discharge air temperature to the discharge air temperature low limit setpoint.
- The cold outdoor air is brought in through the outdoor air damper and when the damper is at (high) minimum position. This causes the discharge air temperature to fall below the discharge air temperature low limit setpoint.

## Heating or Cooling Mode

The heating or cooling mode can be determined in one of two ways:

- By a communicated signal from a BAS or a peer controller
- Automatically, as determined by the controller

A communicated heating signal permits the controller to *only* heat and a communicated cooling signal permits the controller to *only* cool. A communicated auto signal allows the controller to automatically change from heating to cooling and vice versa.

In heating or cooling mode, the controller maintains the zone temperature based on the active heating setpoint and the active cooling setpoint, respectively. The active heating and cooling setpoints are determined by the occupancy mode of the controller.

For 2-pipe and 4-pipe changeover units, normal heat/cool operation *will not* begin until the ability to conduct the desired heating or cooling operation is verified. This is done using the entering water temperature sampling

function, for which a valid entering water temperature is required. When neither a hard wired nor a communicated entering water temperature value is present on changeover units, the controller operates in *only* heating mode and assumes the coil water is hot. The sampling function is not used.

The entering water temperature sampling function is used *only* for changeover applications and for information and troubleshooting. It *does not* affect the operation of the controller.

## Water Temperature Sampling Function

The entering water temperature sampling function is used with 2-pipe and 4-pipe changeover units and requires a valid entering water temperature value. If the entering water temperature value is less than 5°F (2.8°C) above a valid zone temperature value for hydronic heating, and greater than 5°F (2.8°C) below a valid zone temperature value for hydronic cooling, the sampling function is enabled. When the sampling function is enabled, the controller opens the main hydronic valve to allow the water temperature to stabilize. After 3 minutes, the controller again compares the entering water temperature value to the zone temperature value to determine if the desired heating or cooling function can be accomplished. If the entering water temperature value remains out of range to accomplish the desired heating/cooling function, the controller closes the main hydronic valve and waits 60 minutes to attempt another sampling. If the entering water temperature value falls within the required range, it resumes normal heating/cooling operation and disables the sampling function.

## Fan Operation

The controller supports 1-, 2-, 3-speed fans and variable-speed fans. The fan always operates continuously while either heating or cooling during occupied, occupied standby, and occupied bypass operation. During unoccupied operation, the fan cycles between **OFF** and **HIGH**, regardless of the fan configuration. When running in **AUTO** mode, the fan operates differently based on the mode and the type of fan.

For 1-, 2-, and 3-speed fans, each time the fan is enabled, the fan begins operation and runs on high speed for a period of time (0.5 seconds for fan coils and 3 seconds for fan coils) before changing to another speed. Initially running on high speed provides adequate torque to start the fan motor from the **OFF** position.

**Note:** *In occupied mode, the controller requires continuous fan operation because of cascade zone control. In unoccupied mode, the fan cycles.*

## Manual Fan Speed Control

Regardless of the fan type, the fan runs continuously at the desired fan speed during occupied, occupied standby, and occupied bypass operation as follows:



## Start-Up

- When the controller receives a communicated fan speed signal (**HIGH, MEDIUM, LOW**)
- The associated fan speed switch is set to a specific fan speed
- The Supply Fan Speed Request point is overridden

During unoccupied operation, the fan cycles between **OFF** and **HIGH**, regardless of the communicated fan speed signal or fan speed switch setting (unless either of these is **OFF**, which in turn, will control the fan **OFF**).

The fan turns OFF when:

- The controller receives a communicated **OFF** signal
- The fan speed switch is set to **OFF**
- Specific diagnostics are generated
- The default fan speed is set to **OFF** and the fan is operating in the **AUTO** mode

**Note:** The supply fan speed source can be configured for *BAS, local, or default value control* using the *Tracer® TU service tool*.

### AUTO Fan Operation; 1-, 2-, 3-speed Fans

When the controller receives a communicated auto signal (or the associated fan speed switch is set to **AUTO** with no communicated value present), the fan operates in the **AUTO** mode. In **AUTO** mode, the fan operates according to the fan default (configurable using the *Tracer® TU service tool*). The fan speed has multiple speed configurations (default is **AUTO**) or set to **OFF** for both heating and cooling operation. When configured as **AUTO** (and with multiple speeds available), the fan changes based on the required capacity calculated by the control algorithm.

### AUTO Fan Operation; ECM Energy Efficient Mode

When the controller is configured for *Energy Efficient Mode*, by means of the *Fan Operating Mode Request MV* point, the controller and daughter board will minimize energy use by running the fan at the lowest possible speed while maintaining space temperature. The controller will fully utilize valves, economizer, or electric heat which increases fan speed to meet space temperature (unless the fan has been manually controlled. Refer to the preceding section, "[Manual Fan Speed Control](#)," p. 95).

### AUTO Fan Operation; ECM Acoustical Mode

When the controller is configured for *Acoustical Mode*, by means of the *Fan Operating Mode Request MV* point, the controller and daughter board will minimize acoustical nuisance by balancing changes in fan speed and total fan noise. The controller will fully **OPEN** cooling and heating valves before increasing fan speed to meet space temperature (unless the fan has been manually controlled. Refer to "[Manual Fan Speed Control](#)". If multiple stages of electric heat exist the controller will use a single minimum air flow for each stage.

## Exhaust Control

Exhaust control is achieved by a single-speed exhaust fan and controlled by binary output 2 (BO2). Exhaust control, if not present, can be enabled by selecting **Yes** under the *Exhaust Fan Selection* on the *Tracer® TU Configuration* page under the *Equipment Options* group.

**Note:** *Exhaust fan configuration cannot be selected with 3-speed fan operation.*

**Important:** *If exhaust control is added to an existing configuration, all other configuration options should be verified to match the correct equipment options. Temperature and flow setpoints will revert to default values.*

The exhaust function is coordinated with the supply fan and outdoor/return air dampers as follows:

- The exhaust fan energizes when the fan is running and when the outdoor air damper position is greater than or equal to the exhaust fan enable position (or the outside air damper position at which the exhaust fan turns **ON**).
- The exhaust fan turns **OFF** when the fan either turns **OFF** or the outdoor air damper closes to 10 percent below the exhaust fan enable position.
- If the exhaust fan/damper enable setpoint is less than 10 percent, the exhaust output is energized if the outdoor air damper position is at the setpoint and de-energized at 0.

## Valve Operation

The controller supports one or two modulating or two-position valves, depending on the application (refer [Table 42, p. 97](#)). The controller opens and closes the appropriate valve(s) to maintain the active zone temperature setpoint at the heating setpoint in heating mode or the cooling setpoint in cooling mode (refer to "[Cascade Zone Control](#)," p. 94).

### Three-Wire Modulating Valve Operation

The controller supports tri-state 3-wire modulating valve control. Two binary outputs control each valve: one to drive the valve open and one to drive the valve closed. The stroke time for each valve is configurable using the *Tracer® TU service tool*. The controller supports the following:

- Heating
- Cooling
- Heat/cool changeover with a single valve and coil for 2-pipe applications
- Cooling or heat, cool changeover with the main valve, and coil
- Only heating with the auxiliary valve and coil for 4-pipe applications

The controller moves the modulating valve to the desired positions based on heating or cooling requirements.

### Three-Wire Modulating Valve Calibration

Modulating valve calibration is automatic. During normal controller operation, the controller overdrives the actuator (135 percent of the stroke time) whenever there is a request for a position of 0 percent or 100 percent. At either power-up, after a power outage, or when the occupancy status changes to unoccupied, the controller first drives all modulating valves (and dampers) to the closed position. The controller calibrates to the fully **CLOSED** position by over driving the actuator (135 percent of the stroke time). Thereafter, the controller resumes normal operation.

### Two-position Valve Operation

The controller supports two-position valves with a single binary output for each valve. Controllers used for 2-pipe applications support heating, cooling, or heat/cool changeover with a single valve/coil. A controller used for 4-pipe applications supports cooling or heat/cool changeover with a main valve/coil and heating *only* with an auxiliary valve/coil.

### Modulating Outdoor/Return Air Damper

The controller operates the modulating outdoor/return air dampers based on the following:

- Occupancy mode
- Outdoor air temperature (communicated or hard wired sensor)
- Zone temperature
- Setpoint
- Discharge air temperature
- Discharge air temperature setpoint

The minimum position for an outdoor air damper is configurable using the Tracer® TU service tool for both occupied mode and occupied standby mode and for low-speed fan operation. A controller can receive a BAS-communicated outdoor air damper minimum position.

A BAS-communicated minimum position setpoint has priority over all locally configured setpoints. When a communicated minimum position setpoint is not present, the controller uses the configured minimum position for low fan speed whenever the fan is running at low speed, regardless of the occupancy state. Refer to [Table 42](#) and [Table 43](#) for more information about how the controller determines the position of the modulating outdoor air damper.

**Table 42. Modulating outdoor air damper position setpoint determination**

Occupancy	BAS-communicated Setpoint	Fan speed	Active Minimum Setpoint
Unoccupied	Any value	Any value	0 percent (closed).
Occupied			
Occupied bypass	Valid	Any value	BAS-communicated
Occupied standby			
Occupied			
Occupied bypass	Invalid	Low	Occupied low fan minimum
Occupied standby			
Occupied	Invalid	Medium/high	Occupied minimum
Occupied bypass	Invalid	Medium/high	Occupied standby minimum
Occupied standby			

**Table 43. Relationship between outdoor temperature sensors and damper position**

Outdoor Air Temperature	Modulating outdoor air damper position		
	Occupied or Occupied Bypass	Occupied Standby	Unoccupied
No or invalid outdoor air temperature	Open to occupied minimum position	Open to occupied standby minimum position	Closed
Failed outdoor air sensor	Open to occupied minimum position	Open to occupied standby minimum position	Closed
Outdoor air temperature present and economizing possible (Refer to section, "Economizing (Free Cooling)")	Economizing; damper controlled between occupied minimum position and 100 percent	Economizing; damper controlled between occupied standby minimum position and 100 percent	Open and economizing during unit operation; otherwise closed
Outdoor air temperature present and economizing not possible (Refer to section, "Economizing (Free Cooling)")	Open to occupied minimum position	Open to occupied standby minimum position	Closed

### Economizing (Free Cooling)

Cooling with outdoor air (during the times when the temperature is low enough to allow) is referred to as economizing (free cooling). The controller and applications with modulating outside air damper, support economizing. The modulating outdoor air damper provides the first source of cooling for the controller.

The controller initiates economizing if the outdoor air temperature is below the economizer enable point

(configurable using the Tracer® TU service tool). If economizing is initiated, the controller modulates the outdoor air damper (between the active minimum damper position and 100 percent) to control the amount of outdoor air cooling capacity. When the outdoor air temperature rises 5°F (2.8°C) above the economizer enable point, the controller disables economizing and moves the outdoor air damper back to its predetermined minimum position, based on the current occupancy mode or communicated



## Start-Up

---

minimum outdoor air damper position. If an outdoor air temperature value is not present, economizing is disabled.

### Modulating Outdoor Air Damper

The controller supports two-position outdoor air damper actuators. However, a modulating outdoor/return air damper actuator can be used for two-position control. Two-position control can be achieved by not providing an outdoor air temperature (neither hard wired nor communicated) to the controller, and by setting the damper minimum position (using the Tracer<sup>®</sup> TU service tool) to the desired value, typically 100 percent.

### Electric Heat Operation

The controller supports both SCR (modulating) and staged electric heat (1- or 2-stages). SCR heat is *only* a field-installed option. In a unit configured with staged electric heat, the electric heating circuit(s) are cycled **ON** and **OFF** appropriately to maintain the desired space temperature at the active heating setpoint. In a unit configured with SCR (modulating) electric heat, the controller will send a 0 to 10 Volt DC signal to adjust SCR capacity in order to maintain the desired space temperature.

In both staged and modulating electric heat applications, the simultaneous use of electric and hydronic heat is not supported and the controller will operate electric heat *only* when hot water is *not* available (for example, in a changeover unit). In addition, the controller will run the supply fan for 30 seconds after electric heat is turned **OFF** in order to dissipate heat from the unit

**Note:** *This delay does not apply to steam or hydronic heating.*

Factory-configured electric heat units have built-in mechanical protections to prevent dangerously high discharge air temperatures.

### Dehumidification Operation

The controller supports space dehumidification when:

- Mechanical (DX or hydronic) cooling is available
- The heating capacity is located in the reheat position
- The space relative humidity is valid

The space relative humidity can be a BAS-communicated value or come directly from a wired relative humidity sensor. The controller begins to dehumidify the space when the space humidity exceeds the humidity setpoint. The controller continues to dehumidify until the sensed humidity falls below the setpoint minus the relative humidity offset.

### Peer-to-Peer Communication

Peer-to-peer communication is accomplished by means of custom TGP2 programming in the Tracer<sup>®</sup> SC system controller or via hard wiring *only* between controllers.

### Unit Protection Strategies

The following unit protection strategies are initiated when specific conditions exist in order to protect the unit or building from damage:

- Smart reset
- Low coil temperature protection
- Condensate overflow
- Fan status
- Fan off delay
- Filter maintenance timer
- Freeze avoidance
- Freeze protection (discharge air temperature low limit)

#### Smart Reset

The controller will automatically restart a unit that is locked out as a result of a **Low Coil Temp Detection** (BI3) diagnostic. Referred to as *smart reset*, this automatic restart will occur 30 minutes after the diagnostic occurs. If the unit is successfully restarted, the diagnostic is cleared. If the unit undergoes another **Low Coil Temp Detection** diagnostic within a 24-hour period, the unit will be locked out until it is manually reset.

**Note:** *Freeze protection will also perform a smart reset.*

#### Low Coil Temperature Protection

For more information, refer to:

- *BAS-SVX48C-EN Tracer<sup>®</sup> UC400-B Programmable Controller for Blower Coil, Fan Coil, and Unit Ventilator Installation, Operation, and Programming Guide and the preceding section, "Smart Reset".*

#### Condensate Overflow

For more information, refer to:

- *BAS-SVX48C-EN Tracer<sup>®</sup> UC400-B Programmable Controller for Blower Coil, Fan Coil, and Unit Ventilator Installation, Operation, and Programming Guide*

#### Fan Status

In 1-, 2- and 3-speed fans, the status is based on the statuses of the supply fan output multistate and analog points dedicated to fan control. The fan status is reported as **HIGH, MEDIUM, LOW**, and as a percentage, whenever the fan is running. The fan status is reported as **OFF** whenever the fan is not running. In addition, a fan status switch can be connected to binary input 5 (BI5) to monitor the status of the fan for belt-driven or direct-driven units (except Trane Macon factory ECM fan motor units). The fan status switch provides feedback to the controller as follows:

- If the fan is not operating when the controller has the fan controlled to **ON**, the controller generates a *Low Airflow-Supply Fan Failure* diagnostic.
- If the controller energizes the fan output for 1 minute, and the fan status switch indicates no fan operation,

the controller performs a unit shutdown and generates a *Low Airflow-Supply Fan Failure* diagnostic.

- If the fan has been operating normally for one minute, but the fan status switch indicates no fan operation, the same diagnostic is generated.

This manual diagnostic discontinues unit operation until the diagnostic has been cleared from the controller. If a diagnostic reset is sent to the controller, and the fan condition still exists, the controller attempts to run the fan for 1 minute before generating another diagnostic and performing a unit shutdown. A diagnostic reset can be sent to the controller from the Tracer® TU *Alarms* page or by temporarily overriding the *Reset Diagnostic Request* on the Tracer® TU *Binary Status* page.

**Note:** *In the ECM fan application, the VelociTach board will monitor the status of the fan. In case of a failure, the engine board will disable the motor immediately, and the low airflow diagnostic is sent.*

### Fan Off Delay

After heating has been controlled OFF, the controller keeps the fan energized for an additional 30 seconds in order to remove residual heat from the heating source.

### Filter Maintenance Timer

The filter maintenance timer tracks the amount of time (in hours) that the fan is enabled. The Filter Runtime Hours Setpoint (configurable using the Tracer® TU service tool) is used to set the amount of time until maintenance (typically, a filter change) is required. The timer can be enabled/disabled from the **Supply Fan** group on the **Setup Parameters** page in Tracer® TU.

The controller compares the fan run time to filter runtime hours setpoint. Once the setpoint is reached, the controller generates a **Filter Change Required** diagnostic. When the diagnostic is cleared, the controller resets the filter maintenance timer to zero, and the timer begins accumulating fan run time again. The diagnostics can be cleared and the filter timer reset by temporarily overriding the **Filter Timer Reset Request** on the **Binary Status** page or by using the reset button on the **Alarms** page in Tracer® TU.

### Freeze Avoidance

Freeze avoidance is used for low ambient temperature protection. It is initiated *only* when the fan is **OFF**. The controller enters the freeze avoidance mode when the outdoor air temperature is below the freeze avoidance setpoint (configurable using the Tracer® TU service tool). The controller disables freeze avoidance when the outdoor air temperature rises 3°F (1.7°C) above the freeze avoidance setpoint.

The following occurs when the controller is in freeze avoidance mode:

- Valves are driven open to allow water to flow through the coil
- Fan is **OFF**

- Economizing is disabled
- The outdoor/return air damper is closed
- DX cooling is **OFF**
- Electric heat stages are **OFF**

### Freeze Protection (Discharge Air Temperature Low Limit)

The controller monitors the discharge air temperature with a 10 kΩ thermistor wired to AI4. The freeze protection operation is initiated whenever the discharge air temperature falls below the discharge air temperature low limit. The discharge air temperature low limit is configurable using the Tracer® TU service tool. During freeze protection, the controller increases the heating capacity or decreases the cooling capacity in order to raise the discharge air temperature above the low limit. If the discharge air temperature remains below the low limit for 3 minutes, the controller generates a **Discharge Air Temp Limit** diagnostic.

*Freeze protection will also perform a smart reset. Refer to "Smart Reset," p. 98.*



# Routine Maintenance

## ⚠ WARNING

### Hazardous Service Procedures!

Failure to follow all precautions in this manual and on the tags, stickers, and labels could result in death or serious injury.

Technicians, in order to protect themselves from potential electrical, mechanical, and chemical hazards, **MUST** follow precautions in this manual and on the tags, stickers, and labels, as well as the following instructions: Unless specified otherwise, disconnect all electrical power including remote disconnect and discharge all energy storing devices such as capacitors before servicing. Follow proper lockout/tagout procedures to ensure the power can not be inadvertently energized. When necessary to work with live electrical components, have a qualified licensed electrician or other individual who has been trained in handling live electrical components perform these tasks.

## ⚠ WARNING

### Rotating Components!

Failure to secure rotor or disconnect power before servicing could result in rotating components cutting and slashing technician which could result in death or serious injury. The following procedure involves working with rotating components. Disconnect all electric power, including remote disconnects before servicing. Follow proper lockout/ tagout procedures to ensure the power can not be inadvertently energized. Secure rotor to ensure rotor cannot freewheel.

## Maintenance Checklist

Table 44. Maintenance Checklist

Frequency	Maintenance
Every week	Observe unit weekly for any change in running condition and unusual noise.
Every month	<ul style="list-style-type: none"> <li>• Clean or replace air filters if clogged or dirty.</li> </ul>
Every three to six months	<ul style="list-style-type: none"> <li>• Manually rotate the fan wheel to check for obstructions in the housing or interference with fan blades. Remove any obstructions and debris.</li> <li>• Check motor bracket torque.</li> <li>• Inspect and clean drain pans.</li> <li>• Inspect coils for dirt build-up. Clean fins if airflow is clogged.</li> </ul>
Every year	<ul style="list-style-type: none"> <li>• Inspect the unit casing for chips corrosion. If damage is found, clean and repaint.</li> <li>• Clean the fan wheels. Remove any rust from the shaft with an emery cloth and recoat with L.P.S. 3 or equivalent.</li> <li>• Inspect and clean drain pans.</li> <li>• Check damper linkages, fan set screws, and blade adjustment. Clean, but do not lubricate, the nylon damper rod bushings.</li> <li>• Clean damper operators.</li> <li>• Inspect, clean, and tighten all electrical connections and wiring.</li> <li>• Rotate the fan wheel and check for obstructions. The wheel should not rub. Adjust the center if necessary.</li> <li>• Examine flex connections for cracks or leaks. Repair or replace damaged material.</li> </ul>

## Air Filters

## ⚠ WARNING

### Rotating Components!

Failure to secure rotor or disconnect power before servicing could result in rotating components cutting and slashing technician which could result in death or serious injury. The following procedure involves working with rotating components. Disconnect all electric power, including remote disconnects before servicing. Follow proper lockout/ tagout procedures to ensure the power can not be inadvertently energized. Secure rotor to ensure rotor cannot freewheel.

Always install filters with directional arrows pointing toward the fan. For units with high efficiency filters (MERV 8 or MERV 13), the filters need to be replaced with equivalent MERV-rated filters to maintain unit performance.

## Fans

## ⚠ WARNING

### Rotating Components!

Failure to secure rotor or disconnect power before servicing could result in rotating components cutting and slashing technician which could result in death or serious injury. The following procedure involves working with rotating components. Disconnect all electric power, including remote disconnects before servicing. Follow proper lockout/ tagout procedures to ensure the power can not be inadvertently energized. Secure rotor to ensure rotor cannot freewheel.

## Inspecting and Cleaning Fans

Fan sections of air handlers should be inspected every six months at a minimum or more frequently if operating experience dictates. If evidence of microbial growth (mold) is found, identify and remedy the cause

immediately. Refer to [“Diagnostics and Troubleshooting,” p. 108](#) for possible causes and solutions. To clean the fan section:

1. Disconnect all electrical power to the unit.
2. Wearing the appropriate personal protective equipment, remove any contamination.
3. Vacuum the section with a vacuum device that uses high-efficiency particulate arrestance (HEPA) filters with a minimum efficiency of 99.97 percent at 0.3 micron particle size.
4. Thoroughly clean any contaminated area(s) with a mild bleach and water solution or an EPA-approved sanitizer specifically designed for HVAC use.
5. Immediately rinse the affected surfaces thoroughly with fresh water and a fresh sponge to prevent potential corrosion of metal surfaces.
6. Allow the unit to dry completely before putting it back into service.

7. Be careful any contaminated material does not contact other areas of the unit or building. Properly dispose of all contaminated materials and cleaning solution.

### **⚠ WARNING**

#### **Hazardous Voltage!**

**Failure to disconnect power before servicing could result in death or serious injury. Disconnect all electric power, including remote disconnects before servicing. Follow proper lockout/tagout procedures to ensure the power can not be inadvertently energized..**

### Fan Motors

Inspect fan motors periodically for excessive vibration or temperature. Operating conditions will vary the frequency of inspection.

### Torque Rating

Check and adjust fan wheel set screws whenever a component is removed or an adjustment is made. Refer to [Table 45](#) for recommendations.

**Table 45. Recommended torques**

	Torque (in-lb)	Ft-lb	N-m
Fan wheel screw	120-130	10.0-10.8	13.6-14.7

**Table 46. BCHD/BCVD fan, filter, and mixing box general data**

Unit Size	12	18	24	36	54	72	90
<b>Nominal cfm</b>	<b>400</b>	<b>600</b>	<b>800</b>	<b>1200</b>	<b>1800</b>	<b>2400</b>	<b>3000</b>
<b>Air flow</b>							
Minimum cfm	250	375	500	750	1125	1500	1875
Maximum cfm	500	675	1000	1600	2400	3000	4000
<b>Fan data</b>							
Fan wheel, in. (dia. x width)	9.5 x 4.5	9.5 x 4.5	9.5 x 6.0	9.5 x 6.0	12.6 x 9.5	12.6 x 9.5	12.6 x 9.5
RPM range	900-2300	900-2300	800-2000	800-2000	600-1500	600-1500	600-1500
Motor hp	1/2-1	1/2-1	1/2-1	1/2-1	1/2-3	1/2-3	1/2-3
<b>Unit flat filter</b>							
(Qty.) Size	(1) 12 x 24	(1) 12 x 24	(1) 16 x 25	(2) 16 x 20	(2) 20 x 20	(1) 20 x 20 (1) 20 x 25	(3) 16 x 25
Area, sq. ft	2.000	2.000	2.778	4.444	5.556	6.250	8.333
Velocity, ft/min.	200	300	288	270	324	384	360
<b>Angle filter</b>							
(Qty.) Size	(2) 12 x 24	(2) 12 x 24	(2) 12 x 24	(2) 20 x 20	(4) 16 x 20	(6) 16 x 16	(6) 16 x 20
Area, sq. ft	4.000	4.000	4.000	5.556	8.889	8.889	11.111
Velocity, ft/min.	100	150	200	216	203	270	270
<b>Bottom / top access filter box</b>							
(Qty.) Size	(1) 12 x 20	(1) 12 x 24	(1) 16 x 25	(1) 16 x 20 (1) 16 x 16	(1) 16 x 20 (1) 20 x 20	(1) 20 x 25 (1) 20 x 20	(1) 16 x 25 (2) 14 x 25
Area, sq. ft	1.700	2.000	2.800	4.000	5.000	6.300	8.000
Velocity, ft/min.	240	300	288	300	360	384	375
<b>Mixing box</b>							
Damper opening width, in.	15.5	19.5	19.5	31.5	31.5	31.5	31.5
Damper opening height, in.	7	7	7	7	12.75	12.75	12.75
Area, sq. ft	0.753	0.948	0.948	1.531	2.789	2.789	2.789
Velocity, ft/min.	531	633	844	784	645	861	1076

**Note:** Minimum air flow limits apply to units with hot water or electric heat only. There is no minimum airflow limit on cooling on units. Maximum airflow limits are to help prevent moisture carryover.



## Routine Maintenance

**Table 47. BCCD fan and filter general data**

<b>Unit Size</b>	<b>24</b>	<b>36</b>	<b>48</b>	<b>60</b>
<b>Nominal cfm</b>	<b>800</b>	<b>1200</b>	<b>1600</b>	<b>2000</b>
<b>Airflow</b>				
Minimum cfm	500	750	1000	1250
Maximum cfm	1000	1500	2000	2500
<b>Fan data</b>				
Fan wheel, in. (dia. x width)	9.50 x 6.00	9.50x 6.00	12.60 x 8.00	12.60 x 8.00
RPM range	800-2000	800-2000	600-1400	600-1400
Motor hp	0.50-1.00	0.50-1.00	0.50-1.00	0.50-1.00
<b>Unit flat filter</b>				
(Qty.) Size	(1) 12 x 24	(1) 18 x 24	(1) 18 x 20 (1) 12 x 20	(1) 18 x 24 (1) 12 x 24
Area, sq. ft	2.00	3.00	4.20	5.00
Velocity, ft/min.	400	400	380	400

**Note:** Minimum air flow limits apply to units with hot water or electric heat only. There is no minimum airflow limit on cooling only units. Maximum airflow limits are to help prevent moisture carryover.

**Table 48. BCHD/BCVD coil general data**

Unit Size	12	18	24	36	54	72	90
Nominal cfm	400	600	800	1200	1800	2400	3000
<b>Hydronic and DX coil data</b>							
Area - ft <sup>2</sup>	0.89	1.11	1.67	2.67	4.00	5.00	6.67
Width - in. (a), (b)	8.00	8.00	12.00	12.00	18.00	18.00	24.00
Length - in. (d)	16.00	20.00	20.00	32.00	32.00	40.00	40.00
Velocity - ft/min.	450	540	480	450	450	480	450
<b>Hydronic coil data - high capacity</b>							
Area - ft <sup>2</sup>	0.89	1.11	1.67	2.67	3.89	4.86	6.25
Width - in. (a), (c)	8.00	8.00	12.00	12.00	17.50	17.50	22.50
Length - in. (d)	16.00	20.00	20.00	32.00	32.00	40.00	40.00
Velocity - ft/min.	450	540	480	450	463	494	480
<b>1-row coil</b>							
Minimum gpm (e)	1.00	1.00	1.00	1.00	6.10	6.10	7.90
Maximum gpm (f)	5.20	5.20	5.20	5.20	32.60	32.60	42.00
Dry coil weight - lb	4.40	5.20	6.60	9.30	17.60	20.40	25.80
Wet coil weight - lb	5.10	6.00	7.80	11.00	22.40	26.00	32.90
Internal volume - in <sup>3</sup>	19.40	22.20	33.20	47.10	132.90	155.10	196.60
<b>2-row coil - high capacity</b>							
Minimum gpm (e)	1.00	1.00	2.00	2.00	6.10	6.10	7.90
Maximum gpm (f)	5.20	5.20	10.40	10.40	32.60	32.60	42.00
Dry coil weight - lb	5.90	7.00	9.90	14.10	27.20	32.10	39.40
Wet coil weight - lb (kg)	7.20	8.40	12.30	17.60	36.10	42.50	52.60
Internal volume - in <sup>3</sup>	36.00	38.80	66.50	96.90	246.50	288.00	365.50
<b>3-row coil - DX coil</b>							
Internal volume - in <sup>3</sup>	50	60	96	141	225	269	381
<b>4-row coil - standard capacity</b>							
Minimum gpm (e)	n/a	n/a	n/a	n/a	8.80	8.80	11.70
Maximum gpm (f)	n/a	n/a	n/a	n/a	47.00	47.00	62.60
Dry coil weight - lb (g)	n/a	n/a	n/a	n/a	37.20	44.50	58.50
Wet coil weight - lb (g)	n/a	n/a	n/a	n/a	48.30	57.70	77.00
Internal volume - in <sup>3</sup> (g)	n/a	n/a	n/a	n/a	307.40	365.50	512.30
<b>4-row coil - high capacity</b>							
Minimum gpm (e)	2.00	2.00	2.90	2.90	6.10	6.10	7.90
Maximum gpm (f)	10.40	10.40	15.70	15.70	32.60	32.60	42.00
Dry coil weight - lb	10.50	12.40	17.70	25.50	47.00	56.30	73.10
Wet coil weight - lb	13.10	15.50	22.50	32.50	62.70	74.90	97.90
Internal volume - in <sup>3</sup>	72.00	85.80	132.90	193.80	433.00	516.70	688.30
<b>4-row coil - DX coil</b>							
Internal volume - in <sup>3</sup>	65	78	123	182	287	346	484
<b>6-row coil - standard capacity</b>							
Minimum gpm (e)	n/a	n/a	n/a	n/a	8.80	8.80	11.70
Maximum gpm (f)	n/a	n/a	n/a	n/a	47.00	47.00	62.60
Dry coil weight - lb (g)	n/a	n/a	n/a	n/a	52.40	63.10	82.70
Wet coil weight - lb (g)	n/a	n/a	n/a	n/a	68.10	82.00	108.70
Internal volume - in <sup>3</sup> (g)	n/a	n/a	n/a	n/a	434.80	523.40	720.00
<b>6-row coil - high capacity</b>							
Minimum gpm (e)	2.0	2.00	2.90	2.90	6.10	6.10	7.90
Maximum gpm (f)	10.4	10.40	15.70	15.70	32.60	32.60	42.00
Dry coil weight - lb	14.6	17.40	24.70	36.10	65.40	78.60	101.50
Wet coil weight - lb	18.2	21.80	31.50	46.10	87.80	105.60	137.00
Internal volume - in <sup>3</sup>	99.7	121.80	188.30	276.90	620.40	745.90	983.10
<b>6-row coil - DX coil</b>							
Internal volume - in <sup>3</sup>	94	114	176	265	411	500	689
<b>Steam coil data</b>							
Area - ft <sup>2</sup>	0.71	0.88	1.75	2.75	4.13	5.13	6.83
Width - in. (a)	6.00	6.00	12.00	12.00	18.00	18.00	24.00
Length - in. (d)	17.00	21.00	21.00	33.00	33.00	41.00	41.00
Velocity - ft/min.	26.00	25.00	18.00	17.00	17.00	16.00	16.00
<b>1-row coil</b>							
Minimum steam press - psig	2.00	2.00	2.00	2.00	2.00	2.00	2.00
Maximum steam press - psig	15.00	15.00	15.00	15.00	15.00	15.00	15.00
Dry coil weight - lb	16.70	18.70	32.50	41.10	57.40	64.80	84.90
Wet coil weight - lb	18.20	20.40	36.00	45.80	64.50	73.20	96.10
Internal volume - in <sup>3</sup>	41.70	47.70	95.30	130.80	196.10	231.60	308.70

(a) Coil width = Length in the direction of a coil header, typically vertical.

(b) "Hydronic and DX coil data" width dimensions apply only to DX coils (all unit sizes), 1-row standard capacity hydronic coils (unit sizes 012 through 036), and 4-row and 6-row standard capacity hydronic coils (054 through 090).

(c) "High-capacity hydronic coil data" width dimensions apply only to 1-row standard capacity hydronic coils (unit sizes 054 through 090) and 2-row, 4-row, and 6-row high capacity hydronic coils (all unit sizes).



## Routine Maintenance

(d) Coil length = Length of coil in direction of the coil tubes, typically horizontal and perpendicular to airflow.

(e) The minimum waterflow at 1.5 fps tubeside velocity is to ensure the coil self-vents properly. There is no minimum waterflow limit for coils that do not require self venting.

(f) Maximum gpm limits are to prevent erosion and noise problems.

(g) DX coil height and width dimensions are same as comparable hydronic coils. Four- and six-row DX coil dry weight dimensions are same as comparable 4-row and 6-row hydronic coils. A 3-row DX coil dry weight is 25% less than a comparable 4-row hydronic coil. Internal volumes are approximately 6% less than comparable hydronic coils.

**Table 49. BCCD coil general data**

Unit size	24	36	48	60
<b>Nominal cfm</b>	<b>800</b>	<b>1200</b>	<b>1600</b>	<b>2000</b>
<b>Hydronic coil and DX coil data</b>				
Area - ft <sup>2</sup>	1.67	2.50	3.47	4.17
Width - in. (a)	12.00	18.00	20.00	24.00
Length - in. (b)	20.00	20.00	25.00	25.00
Velocity - ft/min	480	480	461	480
<b>1 - row coil</b>				
Minimum gpm (c)	1.40	1.40	2.30	2.70
Maximum gpm (d)	7.10	7.10	11.80	14.10
Dry coil weight - lb	4.80	6.30	8.30	9.60
Wet coil weight - lb	6.20	8.30	10.90	12.70
Internal volume - in <sup>3</sup>	38.80	55.40	72.00	85.90
<b>2 - row coil</b>				
Minimum gpm (c)	2.70	4.10	4.50	5.40
Maximum gpm (d)	14.10	21.20	23.60	28.30
Dry coil weight - lb	7.60	10.50	13.80	16.20
Wet coil weight - lb	10.00	14.10	18.60	21.90
Internal volume - in <sup>3</sup>	66.50	99.70	133.00	157.90
<b>4 - row coil</b>				
Minimum gpm (c)	2.70	4.10	4.50	5.40
Maximum gpm (d)	14.10	21.20	23.60	28.30
Dry coil weight - lb	14.60	20.00	27.00	31.50
Wet coil weight - lb	19.40	27.20	36.90	43.30
Internal volume - in <sup>3</sup>	133.00	199.50	274.30	326.90
<b>6 - row coil</b>				
Minimum gpm (c)	2.70	4.10	4.50	5.40
Maximum gpm (d)	14.10	21.20	23.60	28.30
Dry coil weight - lb	19.70	27.70	37.50	44.10
Wet coil weight - lb	26.70	38.10	51.80	61.10
Internal volume - in <sup>3</sup>	193.90	288.10	396.20	471.00

## Coils

All coils should be kept clean to maintain maximum performance.

### Steam and Water Coils

#### **⚠ WARNING**

##### **Hazardous Voltage!**

Failure to disconnect power before servicing could result in death or serious injury. Disconnect all electric power, including remote disconnects before servicing. Follow proper lockout/tagout procedures to ensure the power can not be inadvertently energized.

#### **⚠ WARNING**

##### **Hazardous Chemicals!**

Failure to follow all safety instructions below could result in death or serious injury. Coil cleaning agents can be either acidic or highly alkaline and can burn severely if contact with skin occurs. Handle chemical carefully and avoid contact with skin. ALWAYS wear Personal Protective Equipment (PPE) including goggles or face shield, chemical resistant gloves, boots, apron or suit as required. For personal safety refer to the cleaning agent manufacturer's Materials Safety Data Sheet and follow all recommended safe handling practices.

To clean steam and water coils:

1. Disconnect all electrical power to the unit.
2. Wearing the appropriate personal protective equipment, use a soft brush to remove loose debris from both sides of the coil.
3. Install a block-off to prevent spray from going through the coil and into a dry section of the unit and/or system ductwork.
4. Mix a high-quality coil cleaning detergent with water according to the manufacturer's instructions.

**Note:** If the detergent is strongly alkaline after mixing (PH 8.5 or higher), it must contain an inhibitor. Follow the cleaning solution manufacturer's instructions regarding the use of the product.

5. Place the mixed solution in a garden pump-up sprayer or high-pressure sprayer. If a high pressure sprayer is to be used:
  - Maintain minimum nozzle spray angle of 15 degrees.
  - Spray perpendicular to the coil face.
  - Keep the nozzle at least 6 inches from the coil.
  - Do *not* exceed 600 psi.
6. Spray the leaving air side of the coil first, then the entering air side.

7. Thoroughly rinse both sides of the coil and the drain pan with cool, clean water.
8. Repeat steps 6 and 7 as necessary.
9. Straighten any coil fins that may have been damaged during the cleaning process.
10. Confirm the drain line is open following the cleaning process.
11. Allow the unit to dry thoroughly before putting it back into service.
12. Replace all panels and parts and restore electrical power to the unit.
13. Be careful any contaminated material does not contact other areas of the unit or building. Properly dispose of all contaminated materials.

### Refrigerant Coils

#### **⚠ WARNING**

##### **Hazardous Pressures!**

Failure to follow safety precautions below could result in coil bursting, which could result in death or serious injury. Coils contain refrigerant under pressure. When cleaning coils, maintain coil cleaning solution temperature under 150°F to avoid excessive pressure in the coil.

To clean refrigerant coils:

1. Disconnect all electrical power to the unit.
2. Wearing the appropriate personal protective equipment, use a soft brush to remove loose debris from both sides of the coil.
3. Install a block-off to prevent spray from going through the coil and into a dry section of the unit and/or system ductwork.
4. Mix a high-quality coil cleaning detergent with water according to the manufacturer's instructions.

**Note:** If the detergent is strongly alkaline after mixing (PH 8.5 or higher), it must contain an inhibitor. Follow the cleaning solution manufacturer's instructions regarding the use of the product.

5. Place the mixed solution in a garden pump-up sprayer or high-pressure sprayer. If a high pressure sprayer is to be used:
  - Maintain minimum nozzle spray angle of 15 degrees.
  - Spray perpendicular to the coil face.
  - Keep the nozzle at least 6 inches from the coil.
  - Do *not* exceed 600 psi.
6. Spray the leaving air side of the coil first, then the entering air side.
7. Thoroughly rinse both sides of the coil and the drain pan with cool, clean water.



## Routine Maintenance

- Repeat steps 6 and 7 as necessary.
- Straighten any coil fins damaged during the cleaning process.
- Confirm the drain line is open following the cleaning process.
- Allow the unit to dry thoroughly before putting it back into service.
- Replace all panels and parts and restore electrical power to the unit.
- Be careful any contaminated material does not contact other areas of the unit or building. Properly dispose of all contaminated materials and cleaning solution.

### Coil Winterization

Water coil winterization procedures consist primarily of draining water from the coil before the heating season. Trane recommends flushing the coil with glycol if coils will be exposed to temperatures below 35 degrees.

#### NOTICE

##### Coil Freeze-up!

**Failure to follow instructions below could result in coil damage. Drain and vent coils when not in use. Trane recommends glycol protection in all possible freezing applications. Use a glycol approved for use with commercial cooling and heating systems and copper tube coils.**

Install field-fitted drains and vents to permit winterization of coils not in use and to assist in evacuating air from the water system during startup. If draining is questionable because of dirt or scale deposits inside the coil, fill the coil with glycol before the heating season begins.

Individual coil types determine how to properly winterize the coil. To determine the coil type find the "Service Model No of Coil" on the coil section nameplate. The coil type is designated by the second and third digits on that model number. For example, if the model number begins with "DUWB," the coil type is UW; if the model number begins with "DW0B," the coil type is W.

**Note:** *On many unit sizes, there are multiple coils in the coil section. Be sure to winterize all coils in a given coil section.*

To winterize type D1, D2, WL, LL, UA, UW, UU, W, P2, P4, P8, WD, 5D, and 5W coils:

- Remove the vent and drain plugs.
- Blow the coil out as completely as possible with compressed air.
- Fill and drain the coil several times with full strength glycol so that it mixes thoroughly with the water retained in the coil.
- Drain the coil out as completely as possible.

- To ensure no water remains in the coil, do not replace the vent and drain plugs until the coils are put back into service.

**Note:** *Use care in removing header plugs from Type P2, P4, and P8 coils. Over-torquing may result in twisted tubes.*

### Moisture Purge Cycle

By its very nature, any HVAC unit with a cooling coil serves as a dehumidifier, reducing the surrounding air's ability to hold water vapor as its temperature falls. This normally doesn't present a problem when the unit is running. However, when the fan stops, water vapor condenses on the cold metal surfaces inside the air handler and remains there until the air warms sufficiently to re-evaporate it. This damp, dark environment—though temporary—can encourage the growth of mold, mildew, and other microbial contaminants.

Providing a moisture purge cycle 15 to 30 minutes after shutdown disperses the cold, humid air inside the air-handling system more evenly throughout the building. This four-step cycle:

- Closes the outdoor air dampers.
- Turns off the cooling coil.
- Opens any variable-air-volume terminals connected to the air handler.
- Operates the supply fan for 10 to 15 minutes.

Air movement discourages water condensation and hastens re-evaporation of any condensate that does happen to form. This simple preventative measure effectively combats microbial growth and curbs moisture-related deterioration of air-handling components.

### Cleaning Non-Porous Surfaces

#### ⚠ WARNING

##### Hazardous Voltage!

**Failure to disconnect power before servicing could result in death or serious injury. Disconnect all electric power, including remote disconnects before servicing. Follow proper lockout/tagout procedures to ensure the power can not be inadvertently energized.**

If microbial growth on a non-porous insulating surface (closed cell insulation or sheet metal surface) is observed:

- Disconnect all electrical power to the unit.
- Wearing the appropriate personal protective equipment, use a brush for sheet metal surfaces or a soft sponge on a foil face or closed cell foam surface to mechanically remove the microbial growth.

**Note:** *Be careful not to damage the non-porous surface of the insulation.*

- Install a block-off to prevent spray from going into a dry section of the unit and/or system ductwork.

4. Thoroughly clean the contaminated area(s) with an EPA-approved sanitizer specifically designed for HVAC use.
5. Rinse the affected surfaces thoroughly with fresh water and a fresh sponge to prevent potential corrosion of the drain pan and drain line
6. Repeat steps 4 and 5 as necessary.
7. Confirm the drain line is open following the cleaning process.
8. Allow the unit to dry thoroughly before putting it back into service.
9. Replace all panels and parts and restore electrical power to the unit.
10. Be careful any contaminated material does not contact other areas of the unit or building. Properly dispose of all contaminated materials and cleaning solution.

### Cleaning Porous Surfaces

#### **⚠ WARNING**

##### **Hazardous Voltage!**

**Failure to disconnect power before servicing could result in death or serious injury. Disconnect all electric power, including remote disconnects before servicing. Follow proper lockout/tagout procedures to ensure the power can not be inadvertently energized.**

To clean a porous insulating surface (fiberglass insulation):

1. Disconnect all electrical power to the unit.
2. Wearing the appropriate personal protective equipment, use a vacuum device with a HEPA filter (99.97 percent efficient at 0.3 micron particles) to remove the accumulated dirt and organic matter.  
**Note:** *Be careful not to tear the insulation surface or edges.*
3. Confirm the drain line is open following the cleaning process.
4. Allow the unit to dry thoroughly before putting it back into service.
5. Replace all panels and parts and restore electrical power to the unit.
6. Be careful any contaminated material does not contact other areas of the unit or building. Properly dispose of all contaminated materials and cleaning solution.

### Drain Pans

#### **⚠ WARNING**

##### **Hazardous Chemicals!**

**Failure to follow all safety instructions below could result in death or serious injury. Coil cleaning agents can be either acidic or highly alkaline and can burn severely if contact with skin occurs. Handle chemical carefully and avoid contact with skin. ALWAYS wear Personal Protective Equipment (PPE) including goggles or face shield, chemical resistant gloves, boots, apron or suit as required. For personal safety refer to the cleaning agent manufacturer's Materials Safety Data Sheet and follow all recommended safe handling practices.**

The condensate drain pan and drain line must be checked to assure the condensate drains as designed. This inspection should occur a minimum of every six months or more often as dictated by operating experience.

If evidence of standing water or condensate overflow exists, identify and remedy the cause immediately. Refer to ["Diagnostics and Troubleshooting," p. 108](#) for possible causes and solutions.

To clean drain pans:

1. Disconnect all electrical power to the unit.
2. Wearing the appropriate personal protective equipment, remove any standing water.
3. Scrape solid matter off of the drain pan.
4. Vacuum the drain pan with a vacuum device that uses high-efficiency particulate arrestance (HEPA) filters with a minimum efficiency of 99.97 percent at 0.3 micron particle size.
5. Thoroughly clean any contaminated area(s) with a mild bleach and water solution or an EPA-approved sanitizer specifically designed for HVAC use.
6. Immediately rinse the affected surfaces thoroughly with fresh water and a fresh sponge to prevent potential corrosion of metal surfaces.
7. Allow the unit to dry completely before putting it back into service.
8. Be careful any contaminated material does not contact other areas of the unit or building. Properly dispose of all contaminated materials and cleaning solution.



# Diagnostics and Troubleshooting

This section is intended to be used as a diagnostic aid only. For detailed repair procedures, contact your local Trane service representative.

## ⚠ WARNING

### Hazardous Service Procedures!

**Failure to follow all precautions in this manual and on the tags, stickers, and labels could result in death or serious injury. Technicians, in order to protect themselves from potential electrical, mechanical, and chemical hazards, MUST follow precautions in this manual and on the tags, stickers, and labels, as well as the following instructions: Unless specified otherwise, disconnect all electrical power including remote disconnect and discharge all energy storing devices such as capacitors before servicing. Follow proper lockout/tagout procedures to ensure the power can not be inadvertently energized. When necessary to work with live electrical components, have a qualified licensed electrician or other individual who has been trained in handling live electrical components perform these tasks.**

**Table 50. Troubleshooting recommendations**

Symptom	Probable Cause	Recommended Action
Motor fails to start	Blown line fuse or open circuit breaker	Replace fuse or reset circuit breaker.
	Improper wiring or connections	Check wiring with diagram supplied on unit.
	Improper current supply	Compare actual supply power with motor nameplate recommendations. Contact power company for adjustments.
Motor stalls	Mechanical failure	Check that fan rotates freely.
	Low line voltage	Check across AC line. Correct voltage if possible.
Excessive vibration	Poor fan alignment	Check motor bracket screws. Check fan position on shaft.
	Motor runs and then dies down	Partial loss of line voltage
Motor does not come up to speed	Low voltage at motor terminals	Check across AC line and correct voltage loss if possible.
	Line wiring to motor too small	Replace with larger sized wiring.
Motor overheats	Overloaded motor	Reduce load or replace with a larger motor.
	Motor fan is clogged with dirt preventing proper ventilation	Remove fan cover, clean fan and replace cover.
Excessive motor noise	Motor mounting bolts loose	Tighten motor mounting bolts.
	Fan rubbing on fan cover	Remove interference in motor fan housing.
Low water coil capacity	Incorrect airflow	Check fan operating condition.
	Incorrect water flow	Inspect the water pumps and valves for proper operation and check the lines for obstructions.
	Incorrect water temperature	Adjust the chiller or boiler to provide the proper water temperature.
	Coil is piped incorrectly	Verify coil piping (see <a href="#">"Piping and Connections," p. 32</a> ).
	Dirty fin surface	Clean the fin surface.
Low refrigerant coil capacity	Incorrect glycol mixture	Verify glycol mixture and adjust if necessary.
	Incorrect airflow	Check fan operating condition.
	Expansion valve is not operating properly or is sized incorrectly	Check sensing bulb temperature. Verify valve operation. Verify proper valve size.
	Incorrect refrigerant charge	Verify refrigerant charge and adjust if necessary.
	Condensing unit failure	Verify condensing unit operation.
	Coil is piped incorrectly	Verify coil piping (see <a href="#">"Piping and Connections," p. 32</a> ).
	Clogged refrigerant line filter	Change filter core.
	Failure of suction/liquid line components	Verify component operation
Low steam coil capacity	Dirty fin surface	Clean the fin surface. Do not use steam to clean refrigerant coils.
	Fin frosting	Verify defrost cycle operation. Verify frostat operation. Verify refrigerant charge.
	Incorrect airflow	Check fan operating condition.
	Coil is piped incorrectly	Verify coil piping (see <a href="#">"Piping and Connections," p. 32</a> ).
	Incorrect steam pressure	Verify steam pressure and adjust if necessary.
Drain pan is overflowing	Excessive steam superheat	Check steam superheat. Steam superheat should not exceed 50°F.
	Failure of steam line/condensate return components	Verify component operation
	Boiler failure	Verify boiler operation
	Dirty fin surface	Clean the fin surface (see <a href="#">"Coils," p. 105</a> ).
	Plugged drain line	Clean drain line
Unit not level	Unit not level	Level unit
	Improper trap design	Design trap per unit installation instructions

**Table 50. Troubleshooting recommendations**

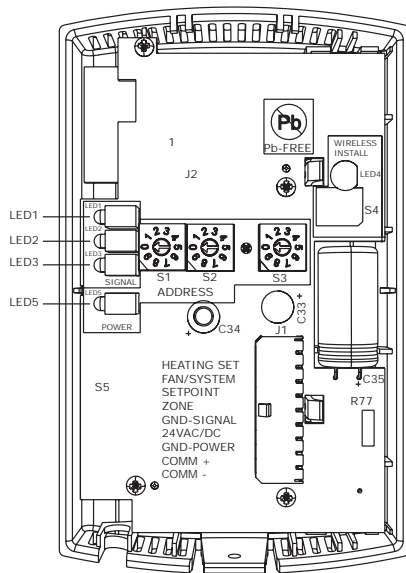
Symptom	Probable Cause	Recommended Action
Standing water in drain pan	Improper trap design	Design trap per unit installation instructions
	Unit not level	Level unit
	Plugged drain line	Clean drain line
Wet interior	Coil face velocity too high	Reduce fan speed
	Improper trap design	Design trap per unit installation instructions
	Drain pan leaks/overflows	Repair leaks
Excess dirt in unit	Condensation on surfaces	Insulate surfaces
	Missing filters	Replace filters
Microbial growth (mold) inside air handler	Filter bypass	Reduce filter bypass by ensuring all blockoffs are in place.
	Standing water in drain pan	See "Standing water in drain pan" above

## Wireless Zone Sensors (WZS)

The receiver for all models has four LEDs: LED1, LED2, LED3, and LED5. The following figure shows their locations.

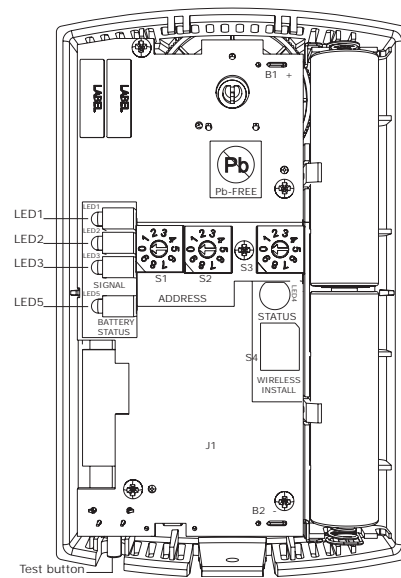
**Note:** To view LEDs on a flush mount receiver on a fan coil unit, the front panel of the unit must be removed.

**Figure 94. Receiver for all fan coil models showing LED locations**



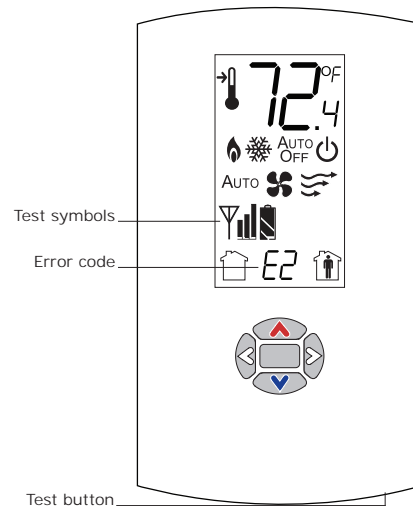
The sensor for a wireless zone sensor (WZS) has four LEDs: LED1, LED2, LED3, and LED5 and a test button. The following figure shows their locations.

**Figure 95. WZS showing LED locations and test button**



The sensor for a wireless display sensor (WDS) has test symbols and error codes that appear on the display, and a test button. See the following figure.

**Figure 96. Wireless display sensor (WDS) shows test symbols and error codes**



## Diagnostics and Troubleshooting

### Receiver Diagnostics

LED1, LED2, and LED3, located on the receiver of all models respond to diagnostics by exhibiting specific blinking patterns. They respond independently of any user action (see the following table).

**Table 51. Diagnostics on the receiver**

LED state	Indicates...
LED1: Off LED2: Off LED3: 1-blink pattern repeated continuously <sup>1</sup>	Disassociated Receiver is not associated, waiting for a sensor. Receiver lost communication with sensor. Receiver has no devices on its wireless personal area network. Association with a device has been manually removed.
LED1: Off LED2: Off LED3: 2-blink pattern repeated continuously <sup>1</sup>	Address set to 000 Address not set to between 001–999.
LED1: Off LED2: Off LED3: 3-blink pattern repeated continuously <sup>1</sup>	Not configured Receiver configuration properties not properly set (defective receiver).

**Note:** <sup>1</sup>Blink pattern is On for 1/4 s, Off for 1/4 s, with 2 s Off between repetitions.

### Sensor Diagnostics

Error codes appear on the WDS when diagnostics occur (see the following table).

LED1, LED2, and LED3, located on the WZS respond to diagnostics by exhibiting specific blinking patterns. View their response by pressing the Test button.

**Table 52. Diagnostics for wireless zone sensors and error code shown on wireless display sensor**

LED state when Test button is pressed on WZS	Error code shown on WDS	Indicates...
n/a	E0, E5, E7	Sensor failure Replace sensor
LED1: Off LED2: Off LED3 <sup>1</sup> : 1-blink pattern repeated 3 times	E1	Disassociated Sensor is not associated with a receiver.
LED1: Off LED2: Off LED3 <sup>1</sup> : 2-blink pattern repeated 3 times	E2	Address set to 000 Address not set to between 001–999.
LED1: Off LED2: Off LED3 <sup>1</sup> : 3-blink pattern repeated 3 times	E3	Software error Replace sensor
LED1: Off LED2: Off LED3 <sup>1</sup> : 4-blink pattern repeated 3 times	E4	Input voltage too high No RF transmission is permitted with an input battery voltage greater than 3.9 V.





**Note:** <sup>1</sup>Blink pattern is On for 1/4 s, Off for 1/4 s, with 2 s Off between repetitions.

### Testing Signal Strength

To initiate a signal strength test, push the Test button on the sensor (see location of Test button in [Figure 95](#) and [Figure 96](#)).

- **Models WZS:** LED1, LED2, and LED3 respond by indicating signal strength. You can view them on the sensor ([Table 53](#)) and the receiver ([Table 54](#)).
- **Model WDS:** Test symbols on the sensor display indicate signal strength ([Table 53](#)). LED1, LED2, and LED3, on the receiver, respond by indicating signal strength ([Table 54](#)).

**Table 53. Observing signal strength on the wireless zone sensor**

User action	LED state	Symbol displayed on WDS	Indicates...
None	LED1: Off LED2: Off LED3: Off	No Test symbols appear	Normal state No Test button press.
Press Test button on the sensor	LED1: Off LED2: Off LED3: Off		Associated; no communication with receiver Associated, but no signal from the receiver after pressing Test button.
	LED1: On LED2: On LED3: On Displays for 5 seconds, then constantly Off		Excellent signal strength Good signal margin for reliable communication.
	LED1: Off LED2: On LED3: On Displays for 5 seconds, then constantly Off		Satisfactory signal strength Adequate signal strength for reliable communication. Moving sensor or receiver may improve signal strength. Increased channel switching may reduce battery life.
	LED1: Off LED2: Off LED3: On Displays for 5 seconds, then constantly Off		Poor signal strength Unreliable communication. Strongly recommend moving the sensor or receiver to a better location.

**Table 54. Observing signal strength on the receiver**

User action	LED state on receiver	Indicates...
None	LED1: Off LED2: Off LED3: Off	Normal state No Test button press.
Press Test button on the sensor	LED1: On LED2: On LED3: On Displays for 5 seconds, then constantly Off	Excellent signal strength Good signal margin for reliable communication.
	LED1: Off LED2: On LED3: On Displays for 5 seconds, then constantly Off	Satisfactory signal strength Adequate signal strength for reliable communication. Moving sensor or receiver may improve signal strength. Increased channel switching may reduce battery life.
	LED1: Off LED2: Off LED3: On Displays for 5 seconds, then constantly Off	Poor signal strength Unreliable communication Strongly recommend moving the sensor or receiver to a better location

## Diagnostics and Troubleshooting

### Testing Battery Status

Initiate a battery status test as follows:

- On the WZS, push the Test button on the sensor (see location on [Figure 95](#)). LED5 on the sensor responds by indicating the level of battery strength, as shown in [Table 55](#).




- On the WDS, push the Test button on the sensor (see location on [Figure 96](#)). In response, a battery test symbol appears on the display. The symbol shown indicates battery life expectancy (see [Table 56](#)).

**Table 55. Battery status indicated by LED5 on the wireless zone sensors**

User action	LED state	Indicates...
Press Test button	Solid green for 5 seconds	Battery is adequate for proper operation.
	Solid red for 5 seconds	25% battery life left. Batteries should be replaced.
	No light	Batteries life expired or not installed properly, or sensor is defective.
None	Blinking red: 1-blink pattern <sup>(a)</sup> repeated 5 times. Cycle repeats every 15 minutes.	Approximately 14 days of operation remain before the battery is too weak to power the sensor.

(a) Blink pattern is On for 1/4 s, Off for 3/4 s, with 2 s Off between repetitions.

**Table 56. Battery status shown on the wireless display sensor**

User action	Battery test symbol	Indicates...	Battery test symbol	Indicates...	Battery test symbol	Indicates...
Press Test button		Full battery power.		50percent battery life left.		25 percent battery life left. Replace batteries. Flashing symbol indicates that approximately 14 days of operation remain before the battery is too weak to power the sensor.

### 24 V Power Status Indicator

LED5 on the receiver of all models (see [Figure 94](#), [page 109](#)) lights and stays constantly On when 24 V power is normal.

### Check Signal Strength on a Site

Use the wireless sensor system to check the signal strength on a site.

- Power up a receiver with a 24 V transformer (user supplied).
- Associate the sensor to a receiver of the same model intended for the job.
- Place the receiver at the desired location.
- Place or hold the sensor at the desired location.
- Press the Test button (S5) on the sensor and observe the signal strength as indicated by LED1, LED2, and LED3 on model WZS (see [Figure 95](#)), and on the display on model WDS (see [Figure 96](#), [page 109](#)).

For more information on interpreting the LEDs and the display symbols that indicate signal strength, see “[Testing Signal Strength](#),” [page 111](#).

### Replacing Sensor Batteries

Sensor battery type, length of life, and installation are addressed in this section.

### Battery Type

#### NOTICE

#### Equipment Damage!

The batteries are manufactured in a ready-to-use state. They are not designed for recharging. Recharging can cause battery leakage or, in some cases, can cause the safety release vent to open.

#### NOTICE

#### Equipment Damage!

Do not attempt to hook up the sensor to a power supply. Equipment damage may result.

Use two non-rechargeable 1.5 V lithium AA batteries in the sensor. To maintain UL rating, use only UL-listed lithium batteries. The sensor ships with Energizer® L91 batteries already installed. Replacement batteries are available at Trane Service Parts Centers (p/n X13770035010) or other local suppliers.

### Battery Life

Battery life is five years under normal conditions. If the sensor is not used for an extended period of time, do one of the following:

- Set the sensor address to 000 to place the sensor into a low-power hibernation mode.
- Remove the batteries

**Note:** If lithium batteries are temporarily unavailable, alkaline batteries can be used. However, alkaline battery life is very short by comparison.

**Notes:** The battery life for model WDS may decrease with extended LCD display activity.

### Battery Installation

#### ⚠ WARNING

##### Prevent Injury!

Batteries can explode or leak and cause burns if installed backwards, disassembled, charged, or exposed to water, fire, or high temperature.

#### ⚠ WARNING

##### Prevent Injury!

Keep away from small children. If swallowed, contact your local poison control center immediately.

1. Observe the polarity indicators that are molded into the cover.
2. Install two batteries (of the type specified in ["Battery Type," page 112](#)) in the battery-holding slot that is molded into the sensor cover.

The sensor has been designed to prevent damage if the batteries are installed backwards, to reduce the potential for injury.

### Manual Association

Before attempting manual or automatic association, the receiver must indicate readiness to associate (one blink pattern of LED3 on receiver). Refer to ["Observing Receiver for Readiness," p. 54](#).

At any time, the manual association method can be used to associate the receiver with the sensor. If an association was previously established between a receiver and a sensor and needs to be re-established, the manual association process may be used. If an association has not yet been established, the automatic association process is recommended (see ["Associating Sensor to Receiver," p. 55](#)).

1. Using a small screwdriver, set the three rotary address switches (locations S1, S2, S3) on the receiver to an address between 001 and 999.

**Note:** An address can be changed at any time after initial association has been established. It is not necessary to power down the receiver or sensor.

2. Set the three rotary address switches (locations S1, S2, S3) on the sensor to the same address as the receiver.
3. Record the address and location of the receiver and sensor pair.
4. After verifying that the receiver and sensor are powered up, press the Test button on the sensor to

establish that the signal strength (["Testing Signal Strength," page 111](#)) and the battery life ["Testing Battery Status," page 112](#)) are adequate for proper functioning.

### Disassociation

The receiver disassociates from the sensor (by removing all stored association information), conducts a channel scan, and restarts itself, if any of the following are true:

- The receiver address is changed from its current setting (001–999)
- The receiver receives a disassociation notification from its associated sensor
- The receiver does not receive a communication from its associated sensor within 50 minutes.
- The sensor and receiver are associated and communicating at the time the sensor is set to 000 and the Test button is pressed.

**Note:** A disassociated sensor will transit an association request every 10 minutes.

### Sensor/Receiver Compatibility

Version 1.5 (p/n X13790854 and X13790855) and higher receivers are compatible with all sensors models and support all functions. Receivers released prior to version 1.5 are compatible with only model WZS.

### Replacing a Failed Sensor or Receiver

**Note:** Receivers ship installed on the unit. To remove the receiver, press in the retention tabs on the underside of the receiver enclosure and push upward.

To replace a failed sensor or receiver:

1. Confirm that the device is disassociated (see [Table 51](#) and [Table 52, p. 110](#)).
2. Set the rotary address switch of the new device to match the address of the remaining sensor or receiver.

**Note:** There is no need to remove power from the remaining device.

3. Apply power to the new device. Association between the new and the remaining devices will automatically occur.

**Note:** When replacing a WDS sensor, the receiver (version 1.5 or higher) will automatically configure the sensor to match the last stored configuration, if the sensor has not been placed into configuration mode and the factory default configuration is still valid. If the sensor configuration does not match the desired system features, it can be manually configured.

## Servicing and Testing WZS

If the wireless sensor system is not working as expected, use the tools and procedure described in this section.

### Servicing and Testing Tools

No special tools or software are necessary to service and test the wireless sensor system. Test the system by using:

- The LEDs on the receiver, LEDs on the model WZS sensor, and the display on the model WDS sensor
- The Test button on the sensor
- The address test mode on the receiver
- A common volt-ohm meter

### Procedure for Testing Zone Sensor

If the wireless zone sensor is not working as expected:

1. Observe LED5 on the receiver. LED5 is On solid green whenever the receiver is powered.
2. Verify that the receiver is properly grounded. Both the GND-SIGNAL (black) wire and the GND-POWER (yellow) wire must be grounded.
3. Press the Test button on the sensor.
  - Model WZS: LED5 should turn On solid green, indicating proper battery strength. LED1, LED2, and LED3 will indicate signal strength.
 

**Note:** *When checking signal strength, both LED1 and LED3 on the receiver and sensor illuminate in unison if the sensor and receiver are associated. Use this feature to confirm association.*
  - Model WDS: Battery life ([“Testing Battery Status,” page 112](#)) and signal strength ([“Testing Signal Strength,” page 111](#)) are indicated on the display.

### Procedure for Testing Receiver

If the receiver is not working as expected:

1. Verify that the receiver is powered.
2. Set the receiver address to 000 to force the zone temperature output and zone temperature setpoint output to their default mode values (see [“Failure and Default Modes”](#)).
3. Measure the receiver output resistance.
4. When the test is complete, reset the receiver address to its previous setting.
5. Press the Test button on the sensor to force re-association.
6. Confirm association and communication by noting LED1, LED2, and LED3 as described in [“Testing Signal Strength,” page 111](#).

### Forcing a Sensor to Transmit

To force a wireless sensor to transmit during servicing, press the Test button on the sensor.

### Output Power Level

The maximum output power level of a wireless sensor set is controlled by software and restricted by channel of operation and agency requirements per country or region. The sensor has a default maximum power level of 10 mW, but the receiver determines the ultimate output power level of the sensor.

### Failure and Default Modes

The following table provides output values for failure and default modes of operation, which can be used for troubleshooting.

**Table 57. Output values - failure and default modes of operation**

Situation	Zone temperature output	Zone setpoint output	Heating setpoint output	Fan/System output
Receiver address = 000	11.17 kΩ, 72.5°F (22.5°C), indefinitely	451 Ω, 72.5°F (22.5°C), indefinitely	501 Ω, 70.5°F (21.4°C), indefinitely	2320 Ω Fan = Auto System = Off
Receiver address = 001 to 999 and: Receiver is powered up, but not is associated, or Receiver has received a disassociation request from the associated sensor.	11.17 kΩ, 72.5°F (22.5°C) Hold for 15 minutes, then open	451 Ω, 72.5°F (22.5°C), Hold for 15 minutes, then open	501 Ω, 70.5°F (21.4°C), indefinitely	2320 Ω Fan = Auto System = Off
Receiver address = 001 to 999 and receiver has not received a communication within 35 minutes from the associated sensor.	Open	Open	Open	Open
Receiver has no power.	Open	Open	Open	Open
Thermistor in sensor has failed to either open or close.	Open	Normal value	Normal value	n/a
Setpoint potentiometer has failed to either open or close.	Normal value	Open	Open	n/a

### Measuring Output Resistance

To measure the resistance of receiver outputs for zone temperature and setpoints for all models, and heating setpoint and fan/system for the WDS:


1. Ensure that the GND-SIGNAL (black) wire and the GND-POWER (yellow) wire are grounded to the transformer.
2. Disconnect the ZONE (white) and SETPOINT (RED) wires from the controller. Disconnect the HEAT SETPOINT (brown) and FAN/SYSTEM (green) wires from the controller, if applicable.
3. Measure resistance as follows:
  - a. All models: Measure between the grounded GND-SIGNAL (black) wire and either the SETPOINT (red) or ZONE (white) wire. Compare resistance measurements to those in [Table 58](#).

**Table 58. Receiver resistance table for all models**

Zone or setpoint temperature	Nominal zone temperature output resistance	Nominal setpoint/heating setpoint output resistance
55°F (12.8°C)	17.47 kΩ	792 Ω
60°F (15.6°C)	15.3 kΩ	695 Ω
65°F (18.3°C)	13.49 kΩ	597 Ω
70°F (21.1°C)	11.9 kΩ	500 Ω
75°F (23.9°C)	10.5 kΩ	403 Ω
80°F (26.7°C)	9.3 kΩ	305 Ω
85°F (29.4°C)	8.25 kΩ	208 Ω

- b. WDS only: Measure between the grounded GND-SIGNAL (black) wire and the FAN/SYSTEM (green) wire. Compare resistance measurements to those given in [Table 59](#).

**Table 60. Thermostat troubleshooting**

Probable Cause/Symptom	Explanation
No display	Check for voltage at thermostat; display is blank when voltage is not present.
System fan does not come on properly	Verify wiring is correct. Check connections are correct (see Configuration Mode Setting 5).
Thermostat turns on and off too frequently	Adjust temperature differential (see Configuration Mode Setting 10).
Room temperature is not correct	Calibrate thermostat (see Configuration Mode Setting 14). If remote sensor is used, check connections.
 Displays Lock symbol when any button is pressed	Thermostat has the button lockout function activated (see Lockout feature and Configuration Mode Setting 15).
-- Displays instead of room temperature	Check for bad connection if remote sensor is used (see Configuration Mode Setting 4).
Heat or cool not coming on (No pipe sensor)	Verify wiring is correct. Gently pull on each wire to verify there is a good connection, verify configuration settings.
Heat or cool not coming on (Pipe sensor is connected)	Check pipe sensor temperature by pressing up and down buttons in. If out of range, outputs may not turn on (see Configuration Mode Settings 6-9).

**Note:** The output circuits are not electrically powered; consequently, resistance can be measured without risk of damage to the volt-ohm meter.

**Table 59. Receiver resistance table for model WDS**

Fan command	Nominal output resistance
High	16,130 Ω
Med	13,320 Ω
Low	10,770 Ω
Auto	2320 Ω
Off	4870 Ω

### Cleaning the Sensor

#### NOTICE

#### Equipment Damage!

Spraying glass cleaner or any other solution directly on the sensor may damage it.

You can clean the sensor by applying glass cleaner to a soft, non-abrasive cloth, and gently wiping the face, including the buttons and LCD display. Use of a pre-moistened towelette designed for lens or screen cleaning is also acceptable.

Avoid inadvertent pressing of the Occupied/Unoccupied buttons on the keypad on the WDS sensor as this may result in an unwanted timed override or settings change.

## Thermostat

## Tracer® ZN520 Controllers

### LED Activity

**Green Status LED** The green LED normally indicates whether the controller is powered on (24 Vac supplied). Refer to the following table.

**Table 61. Green status LED activity for Tracer® ZN520 controllers**

Green LED Activity	Description
On continuously	Power on (normal operation).
Blinks (one blink)	The controller is in manual output test mode. No diagnostics present.
Blinks (two blinks)	The controller is in manual output test mode. One or more diagnostics are present.
LED blinks (1/4 second on, 1/4 second, off for 10 seconds)	Wink mode. <sup>(a)</sup>
LED off	Power is off. Controller failure. Test button is pressed.

(a) The Wink feature allows you to identify a controller. By sending a request from the Rover service tool, you can request the controller to wink (blink on and off as a notification that the controller received the signal). The green LED blinks (1/4 second on, 1/4 second off for 10 seconds) during Wink mode.

**Yellow Comm LED** The yellow comm LED blinks at the rate the controller receives communication. The yellow LED does not blink when the controller is transmitting communication data. Refer to the following table.

**Table 62. Yellow comm LED activity for Tracer® ZN520 controllers**

LED Activity	Description
Off continuously	The controller is not detecting any communication. (Normal for standalone applications.)
LED blinks or flickers	The controller detects communication. (Normal for communicating applications, including data sharing.)
LED on continuously	Abnormal condition or extremely high traffic on the link. High traffic on the link.

**Red Service LED** The red LED normally indicates if the unit controller is operating properly or not. Refer to the following table.

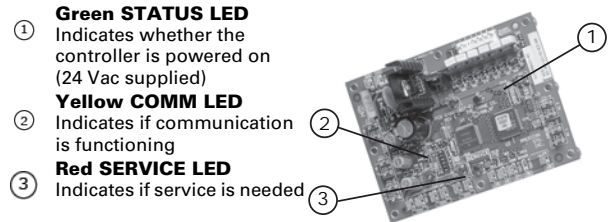
**Table 63. Red service LED activity for Tracer® ZN520 controllers**

LED Activity	Description
Off continuously after power is applied to the controller.	Normal operation
On continuously, even when power is first applied to the controller.	Someone is pressing the Service button or the controller has failed.
LED flashes about once every second.	Uninstall (normal controller mode). To restore normal operation, use the Rover service tool.
Black Service push button.	Use the Service button to install the Tracer® ZN520 controller in a communication network.

**Note:** If the service push button is held down for more than 15 seconds, the Tracer® controller will uninstall itself from the ICS communication

network and shut down all unit operation. This mode is indicated by the red Service LED flashing once every second. See the Red Service LED section. Use the Rover service tool to restore the unit to normal operation. Refer to the service tool product literature for more information

**Figure 97. LED light status on ZN520 controller**



- ① **Green STATUS LED**  
Indicates whether the controller is powered on (24 Vac supplied)
- ② **Yellow COMM LED**  
Indicates if communication is functioning
- ③ **Red SERVICE LED**  
Indicates if service is needed

### Manual Output Test

The purpose of the manual output test sequence for Tracer® ZN520 controllers is to verify output and end device operation. Use the manual output test to:

- Verify output wiring and operation without using Rover, service tool
- Force the water valve to open and balance the hydronic system

**Note:** The manual output test is not an automatic cycle. You must press the TEST button to proceed through each step.

The controller observes all diagnostics that occur during the test sequence. Although an automatic diagnostic reset sequence exists as part of the controller's normal operation, the automatic diagnostic reset feature is not active during the test sequence.

If left in an individual test step, the controller remains in test mode for 60 minutes and then exits to normal operation.

Many service calls are due to unit diagnostics. The test sequence resets unit diagnostics and attempts to restore normal unit operation prior to testing the outputs. If the diagnostics remain after a reset, the STATUS LED indicates the diagnostic condition is still present (two blinks).

### Manual Output Test Procedure

Follow the procedure below to test Tracer® ZN520 controllers.

1. Press and hold the TEST button for at least two seconds (not exceeding 5 seconds), and then release, to start the test mode.
2. The test sequence will turn off all outputs and then attempt to clear all diagnostics.
3. Press the TEST button several more times (no more than once per second) to advance through the test sequence.

The outputs are not subject to minimum times during the test sequence. However, the test sequence only permits one step per second which limits minimum output time.

The green LED is turned off when the TEST button is pressed. To begin the manual output test mode, press and hold the TEST button (turning off the green LED) for at least two seconds. The green LED will begin to blink, indicating the controller is in test mode. See the following table.

**Table 64. Test sequence for 1-heat/1-cool configurations for Tracer® ZN520**

Steps	Fan BOP1-3	Cool Output BOP4 <sup>1</sup>	Heat Output BOP5	Damper BOP6
1. Off	Off	Off	Off	Closed
2. Fan High	High	Off <sup>2</sup>	Off	Closed
3. Fan Medium	Medium	Off	Off	Closed
4. Fan Low	Low	Off	Off	Closed
5. Cool	High	On	Off	Closed
6. Heat	High	Off	On	Closed
7. Fresh Air Damper	High	Off	Off	Open <sup>3</sup>
8. Exit	4			

**Notes:** <sup>1</sup>For all 1-heat/1-cool applications including 2-pipe changeover, BOP4 energizes in the cooling test stage and BOP5 energizes in the heat test stage. This occurs even though during normal 2-pipe changeover operation BOP4 controls the unit valve for both cooling and heating.  
<sup>2</sup>At the beginning of the Fan High step, the controller attempts to clear all diagnostics  
<sup>3</sup>The fresh air damper (BOP6) only energizes during this step if binary output 6 has been configured as a fresh air damper.  
<sup>4</sup>After the Fresh Air Damper step, the test sequence performs the Exit step. This initiates a reset and attempts to return the controller to normal operation

**Table 65. Tracer® ZN520 test sequence**

Step	Fan		Main Valve	Electric Heat or Aux. Valve		Fresh Air Damper	Generic/Baseboard Heat			
	J1-1	J1-2	J1-3	J1-5	J1-6	J1-9	J1-10	J1-11	J1-12	TB4-1
1. Off <sup>1</sup>	Off	Off	Off	Off	On EH: off	Off	aux: on	Off	On	Off
2. Fan high <sup>2</sup>	High	Off	Off	Off	Off	Off	Off	Off	Off	Off
3. <sup>3</sup>	Off		Off	Off	Off	Off	Off	Off	Off	Off
4. Fan low	Off	Off	Low	Off	Off	Off	Off	Off	Off	Off
5. Main open	High	Off	Off	On	Off	Off	Off	Off	Off	Off
6. Main close, EH1 on	High	Off	Off	Off	On	On	Off	Off	Off	Off
7. Aux. open	High EH1 on	Exh <sup>4</sup>	Off	Off	Off	On	Off	Off	Off	Off
8. Aux. close, damper open	High	Off	Off	Off	Off	Off EH1 off	On EH2 on	On	Off	Off
9. Damper close	High	Off	Off	Off	Off	Off	Off	Off	On	Off
10. Generic/baseboard heat energized	High	Off	Off	Off	Off	Off	Off	Off	Off	On
11. Exit <sup>5</sup>	Exit									

**Notes:** <sup>1</sup>Upon entering manual output test mode, the controller turns off all fan and electric heat outputs and drives.  
<sup>2</sup>At the beginning of Step 2, the controller attempts to clear all diagnostics.  
<sup>3</sup>The low fan speed output energizes at Step 3. If the unit is configured for a 1-speed fan, the fan remains on high speed at Step 3.  
<sup>4</sup>If the unit is configured for a 1- or 2-speed fan, and BOP2 is configured for an exhaust fan, the exhaust fan output energizes on Step 7. The exhaust fan output is shared with medium speed.  
<sup>5</sup>After Step 10, the test sequence performs an exit. This initiates a reset and attempts to return the controller to normal operation.

### Translating Multiple Diagnostics

The controller senses and records each diagnostic independently of other diagnostics. It is possible to have multiple diagnostics present simultaneously. The diagnostics are reported in the order they occur.

Possible diagnostics include:

- Low coil temperature detection
- Condensate overflow
- Low air flow—fan status
- Discharge air temp limit
- Space temperature failure<sup>1</sup>
- Entering water temp failure<sup>1</sup>
- Discharge air temp failure

- Outdoor air temp failure<sup>1</sup>
- Local setpoint failure<sup>1</sup>
- Local fan mode failure<sup>1</sup>
- CO<sub>2</sub> sensor failure<sup>1</sup>
- Generic AIP failure<sup>1</sup>
- Humidity input failure<sup>1</sup>
- Defrosting compressor lockout<sup>1</sup>
- Maintenance required<sup>2</sup>
- Invalid Unit Configuration<sup>2</sup>
- Generic temperature failure<sup>2</sup>
- Discharge air low limit

<sup>1</sup> Non-latching diagnostics automatically reset when the input is present and valid.  
<sup>2</sup> Does not apply to the Tracer® UC400-B controller.



## Diagnostics and Troubleshooting

### Resetting Diagnostics

There are seven ways to reset unit diagnostics:

- Automatically by the controller
- By initiating a manual output test at the controller.
- By cycling power to the controller
- By using a building automation system
- By using the Rover service tool
- By using any other communicating device able to access the controller's diagnostic reset input.
- By cycling the fan switch from off to any speed setting.

### Automatic Reset by the Controller

The controller includes an automatic diagnostic reset function which attempts to automatically restore the unit when a low temperature diagnostic occurs.

**Note:** *The controller implements the automatic diagnostic reset function only once every 24 hours. For the controller to increment the 24-hour timer, you must maintain power to the controller. Cycling power resets all timers and counters.*

After the controller detects the first low temperature diagnostic, the unit waits 30 minutes before invoking the automatic diagnostic reset function. The automatic diagnostic reset function clears the special diagnostic and

attempts to restore the controller to normal operation. The controller resumes normal operation until another diagnostic occurs.

**Note:** *The automatic diagnostic reset function does not operate during the manual output test sequence.*

If a special diagnostic occurs within 24 hours after an automatic diagnostic reset, the controller must be manually reset. Other possible methods of resetting diagnostics are described in the sections that follow.

### Manual Output Test

You can use the Test button on the controller either during installation to verify proper end device operation or during troubleshooting. When you press the Test button, the controller exercises all outputs in a predefined sequence.

The first and last outputs of the sequence reset the controller diagnostics.

### Cycling Power

When someone turns off the controller's 24 Vac power, then re-applies power, the unit cycles through a power up sequence. By default, the controller attempts to reset all diagnostics at power up. Diagnostics present at power-up and those that occur after power-up are handled according to the defined unit diagnostics sequences (see the following two tables).

**Table 66. Tracer® ZN520 controller diagnostics**

Diagnostic	Fan	Other Outputs <sup>1</sup>
Condensate overflow	Off	Valves Closed, Fresh air damper Closed, Electric heat Off, Baseboard heat Off
Low temperature detection	Off	Valves Open, Fresh air damper Closed, Electric heat Off, Baseboard heat Off
Low air flow - fan failure	Off	Valves Closed, Fresh air damper Closed, Electric heat Off, Baseboard heat Off
Space temperature failure	Off	Valves Closed, Fresh air damper Closed, Electric heat Off, Baseboard heat Off
Entering water temp failure	On	Valves Enabled <sup>1</sup> , Fresh air damper Enabled <sup>2</sup> , Electric heat Enabled <sup>2</sup> , Baseboard heat Off
Discharge air temp low limit	Off	Valves Open, Fresh air damper Closed, Electric heat Off, Baseboard heat Off
Discharge air temp failure	Off	Valves Closed, Fresh air damper Closed, Electric heat Off, Baseboard heat Off
Fresh air temp failure	On	Valves Enabled, Fresh air damper Minimum position <sup>3</sup> , Electric heat Enabled, Baseboard heat Enabled
Relative humidity failure	On	Valves Enabled, Fresh air damper Enabled, Electric heat Enabled, Baseboard heat Enabled
Generic 4–20mA failure	On	Valves Enabled, Fresh air damper Enabled, Electric heat Enabled, Baseboard heat Enabled
CO <sub>2</sub> Input failure	On	Valves Enabled, Fresh air damper Enabled, Electric heat Enabled, Baseboard heat Enabled
Maintenance required	On	Valves Enabled, Fresh air damper Enabled, Electric heat Enabled, Baseboard heat Enabled
Local fan mode failure	On	Valves Enabled, Fresh air damper Enabled, Electric heat Enabled, Baseboard heat Enabled
Local setpoint failure	On	Valves Enabled, Fresh air damper Enabled, Electric heat Enabled, Baseboard heat Enabled
Invalid unit configuration	Off	Valves Disabled, Fresh air damper Disabled, Electric heat Disabled, Baseboard heat Disabled
Normal—power up	On	Valves Enabled, Fresh air damper Enabled, Electric heat Enabled

**Notes:** <sup>1</sup>The generic binary output (TB4-1, TB4-2) state is unaffected by all unit diagnostics.

<sup>2</sup>When the entering water temperature is required but not present, the Tracer® ZN520 controller generates a diagnostic to indicate the sensor loss condition. The controller automatically clears the diagnostic once a valid entering water temperature value is present (non-latching diagnostic). When the entering water temperature sensor fails, the controller prohibits all hydronic cooling operation, but allows the delivery of heat when heating is required. In the Cool mode, all cooling is locked-out, but normal fan and outdoor air damper operation is permitted.

<sup>3</sup>When the outdoor air temperature sensor has failed or is not present, the Tracer® ZN520 controller generates a diagnostic to indicate the sensor loss condition. The controller automatically clears the diagnostic once a valid outdoor air temperature value is present (non-latching diagnostic). When the outdoor air temperature sensor fails or is not present, the controller prohibits economizer operation.

## Building Automation System

Some building automation systems can reset diagnostics in the Tracer<sup>®</sup> ZN520 controllers. For more complete information, refer to the product literature for the building automation system.

## Fans with ZN520 Controllers

### Cycling the Fan Switch for Tracer<sup>®</sup> ZN520 Controller

If the user cycles the fan speed switch from off to any speed, the controller resets all diagnostics. Diagnostics may recur immediately if the problem still exists.

The green LED normally indicates whether or not the controller is powered on (24 Vac).

### Trane Service Tools

Rover, Trane's service tool for the controller, can reset diagnostics present in the controller. For complete information about Rover, refer to:

EMTX-SVX01\*-EN Installation, Operation, and Programming: Rover<sup>™</sup> Service Tool

### Alarm Reset

Any device that can communicate alarm reset information can reset diagnostics present in the controller.

**Table 67. Fan does not energize**

Probable Cause	Explanation
Random start observed	After power-up, the controller always observes a random start that varies between 0 and 30 seconds. The controller remains off until the random start time expires.
Power-up control wait	When power-up control wait is enabled (non-zero time), the controller remains off until one of two conditions occurs: 1. The controller exits power-up control wait once it receives communicated information. 2. The controller exits power-up control wait once the power-up control wait time expires.
Cycling fan operation	When the fan mode switch is in the auto position, the unit fan cycles off when there is no call for heating or cooling. The heating/cooling sources cycle on or off periodically with the unit fan to match the capacity according to pulse width modulation (PWM) logic.
Unoccupied operation	The fan cycles with capacity when the unit is in unoccupied mode. This occurs even if the unit is in continuous fan operation. While unoccupied, the fan cycles on or off with heating/cooling to provide varying amounts of heating or cooling to the space, to match the capacity diagnostics according to pulse-width-modulation (PWM) logic.
Fan mode off	When using the local fan mode switch to determine the fan operation, the off position controls the unit fan to off.
Requested mode: off	It is possible to communicate the operating mode (such as off, heat, and cool) to the controller. When "off" is communicated to the controller, the unit controls the fan to off. The unit is not capable of heating or cooling when the controller is in this mode.
Diagnostic present	A specific list of diagnostics affects fan operation. For more information, see <a href="#">Table 66, p. 118</a> .
No power to the controller	If the controller does not have power, the unit fan does not operate. For the Tracer <sup>®</sup> controller to operate normally, it must have an input voltage of 24 Vac. When the green LED is off continuously, the controller does not have sufficient power or has failed.
Unit configuration	The controller must be properly configured based on the actual installed end devices and application. When the unit configuration does not match the actual end devices, the valves may not work correctly.
Manual output test	The controller includes a manual output test sequence to verify binary output operation and the associated wiring. However, based on the current step in the test sequence, the unit fan may not be powered on. Refer to " <a href="#">Manual Output Test</a> ," p. 116.
Unit wiring	The wiring between the controller outputs and the fan relays and contacts must be present and correct for normal fan operation. Refer to the specific unit wiring diagrams on the unit.

## Valves with ZN520 Controllers

**Table 68. Valves remain closed**

Probable Cause	Explanation
Normal operation	The controller opens and closes the valves to meet the unit capacity requirements.
Requested mode: off	It is possible to communicate the operating mode (such as off, heat, and cool) to the controller. When off is communicated to the controller, the unit controls the fan to off. The unit is not capable of heating or cooling when the controller is in this mode.
Valve override	The controller can communicate a valve override request. This request affects the valve operation.
Manual output test	The controller includes a manual output test sequence to verify analog and binary output operation and the associated wiring. However, based on the current step in the test sequence, the valves may not be open. Refer to the " <a href="#">Manual Output Test</a> ," p. 116.
Diagnostic present	A specific list of diagnostics affects valve operation. For more information, see <a href="#">Table 66, p. 118</a> .
Sampling logic	The controller includes entering water temperature sampling logic that automatically invokes during 2-pipe or 4-pipe changeover. It determines when the entering water temperature is either too cool or too hot for the desired heating or cooling mode.



## Diagnostics and Troubleshooting

**Table 68. Valves remain closed (continued)**

Probable Cause	Explanation
Unit configuration	The controller must be properly configured based on the actual installed end devices and application. When the unit configuration does not match the actual end device, the valves may not work correctly.
No power to the controller	If the controller does not have power, the unit fan does not operate. For the Tracer® ZN.010, 510 controller to operate normally, it must have an input voltage of 24 Vac. When the green LED is off continuously, the controller does not have sufficient power or has failed.
Unit wiring	The wiring between the controller outputs and the valve(s) must be present and correct for normal valve operation. Refer to the unit wiring diagrams on the unit.
Valve configuration	For modulating valves, ensure the stroke time is set correctly. Refer to <a href="#">Table 16, p. 27</a> .

**Table 69. Valves remain open**

Probable Cause	Explanation
Normal operation	The controller opens and closes the valves to meet the unit capacity requirements.
Valve override	The controller can communicate a valve override request to affect the valve operation.
Manual output test	The controller includes a manual output test sequence that verifies analog and binary output operation and the associated wiring. However, based on the current step in the test sequence, the valves may be open. Refer to the <a href="#">"Manual Output Test," p. 116</a> .
Diagnostic present	A specific list of diagnostics affects valve operation. For more information, see <a href="#">Table 66, p. 118</a> .
Sampling logic	The controller includes entering water temperature sampling logic that automatically invokes during 2-pipe or 4-pipe changeover to determine if the entering water temperature is correct for the unit operating mode.
Unit configuration	The controller must be properly configured based on the actual installed end devices and application. When the unit configuration does not match the actual end device, the valves may not work correctly.
Unit wiring	The wiring between the controller outputs and the valve(s) must be present and correct for normal valve operation. Refer to the unit wiring diagrams on the unit.
Valve configuration	For modulating valves, ensure the stroke time is set correctly. Refer to <a href="#">Table 16, p. 27</a> .

## Electric Heat with ZN520 Controllers

**Table 70. Electric heat not operating**

Probable Cause	Explanation
Normal operation	The controller cycles electric heat on and off to meet the unit capacity requirements.
Requested mode: off	It is possible to communicate the operating mode (such as off, heat, cool) to the controller. When off is communicated to the controller, the units shuts off the electric heat.
Communicated disable	Numerous communicated requests may disable electric heat, including an auxiliary heat enable input and the heat/cool mode input. Depending on the state of the communicated request, the unit may disable electric heat.
Manual output test	The controller includes a manual output test sequence that verifies analog and binary output operation and associated output wiring. However, based on the current step in the test sequence, the electric heat may not be on. Refer to <a href="#">"Manual Output Test," page 116</a> .
Diagnostic present	A specific list of diagnostics affects electric heat operation. For more information, see <a href="#">"Diagnostics and Troubleshooting," page 108</a> .
Unit configuration	The controller must be properly configured based on the actual installed end devices and application. When the unit configuration does not match the actual end device, the electric heat may not work properly.
No power to the controller	If the controller does not have power, electric heat does not operate. For the controller to operate normally, a 24 Vac input voltage must be applied. When the green LED is off continuously, the controller does not have sufficient power or has failed.
Unit wiring	The wiring between the controller outputs and the electric heat contacts must be present and correct for normal electric heat operation. Refer to the unit wiring diagrams on the unit.
ECM motor/Motor control board failure	ECM controls include sophisticated fan proving / interlock circuitry that will disable electric heat if one or more motors are not performing normally
Hot water is present on a changeover unit	On units with changeover coil and electric heat, simultaneous operation of hydronic heat and electric heat is not allowed.

### Fresh Air Damper with ZN520 Controllers

**Table 71. Fresh air damper stays open**

Probable Cause	Explanation
Normal operation	The controller opens and closes the fresh air damper based on the controller's occupancy mode and fan status. Normally, the fresh air damper is open during occupied mode when the fan is running and closed during unoccupied mode.
Manual output test	The controller includes a manual output test sequence that verifies analog and binary output operation and associated output wiring. However, based on the current step in the test sequence, the fresh air damper may not be open. Refer to <a href="#">"Manual Output Test," page 116</a> .
Unit configuration	The controller must be properly configured based on the actual installed end devices and application. When the unit configuration does not match the actual end device, the damper may not work correctly.
Unit wiring	The wiring between the controller outputs and the fresh air damper must be present and correct for normal damper operation. Refer to the unit wiring diagrams on the unit.

**Table 72. Fresh air damper stays closed**

Probable Cause	Explanation
Normal operation	The controller opens and closes the fresh air damper based on the controller's occupancy mode and fan status. Normally, the fresh air damper is open during occupied mode when the fan is running and closed during unoccupied mode.
Warmup and cooldown	The controller includes both a warmup and cooldown sequence to keep the fresh air damper closed during the transition from unoccupied to occupied. This is an attempt to bring the space under control as quickly as possible.
Requested mode: off	It is possible to communicate the operating mode (such as off, heat, cool) to the controller. When off is communicated to the controller, the unit closes the fresh air damper.
Manual output test	The controller includes a manual output test sequence that verifies analog and binary output operation and associated output wiring. However, based on the current step in the test sequence, the fresh air damper may not be open. Refer to <a href="#">"Manual Output Test," page 116</a> .
Diagnostic present	A specific list of diagnostics effects fresh air damper operation. For more information, see <a href="#">"Diagnostics and Troubleshooting," page 108</a> .
Unit configuration	The controller must be properly configured based on the actual installed end devices and application. When the unit configuration does not match the actual end device, the damper may not work correctly.
No power to the controller	If the controller does not have power, the fresh air damper does not operate. For the controller to operate normally, a 24 Vac input voltage must be applied. When the green LED is off continuously, the controller does not have sufficient power or has failed.
Unit wiring	The wiring between the controller outputs and the fresh air damper must be present and correct for normal damper operation. Refer to the unit wiring diagrams on the unit.



## Diagnostics and Troubleshooting

# Tracer<sup>®</sup> UC400-B Controller

## LED Activity

LED activity, an indication or troubleshooting tip for each, and any related notes.

There are 15 LEDs on the front of the Tracer<sup>®</sup> UC400-B controller. The following table provides a description of LED activity.

**Table 73. LED activity and troubleshooting tips for Tracer<sup>®</sup> UC400-B controller**

LED Name	Activities	Indication and Troubleshooting Tips	Notes
Marquee LED	Shows solid green when the unit is <b>powered</b> and no alarm exists	Indicates normal operation	When powering the UC400-B and expansion module, the Marquee LED will blink <b>RED</b> , blink <b>GREEN</b> (indicating activated and controller/expansion module are communicating), and then stay <b>GREEN CONTINUOUSLY</b> (indicating normal power operation).
	Shows blinking green during a device reset or firmware download	Indicates normal operation	
	Shows solid red when the unit is <b>powered</b> , but represents low power or a malfunction	<b>If low power:</b> could be under voltage or the microprocessor has malfunction. Measure for the expected value range. For more information, refer to <i>Installation, Operation, and Maintenance: Tracer<sup>®</sup> UC400-B Programmable Controller</i> (BAS-SVX20C-EN, or the most recent version). <b>If malfunction:</b> un-power and then re-power unit to bring the unit back up to normal operation.	
	Shows blinking red when an <b>alarm</b> or fault exists	An alarm or fault condition will occur if the value for a given point is invalid or outside the configured limits for the point. Alarm and fault conditions vary, and they can be configured by the programmer.	
	LED not lit	Indicates power is OFF or there is a malfunction <b>OFF</b> or <b>malfunction</b> ; cycle the power. For more information, refer to <i>Installation, Operation, and Maintenance: Tracer<sup>®</sup> UC400-B Programmable Controller</i> (BAS-SVX20C-EN, or the most recent version).	
Link and IMC	TX blinks green	Blinks at the data transfer rate when the unit transfers data to other devices on the link	TX LED: Regardless of connectivity or not, this LED will constantly blink as it continually looks for devices to communicate to. LED not lit: Determine if, for example, a Tracer <sup>®</sup> SC or BACnet device is trying to talk to the controller or if it is capable of talking to the controller. Also determine if the communication status shows down all of the time. In addition, check polarity and baud rate.  For more information, refer to <i>Installation, Operation, and Maintenance: Tracer<sup>®</sup> UC400-B Programmable Controller</i> (BAS-SVX20C-EN, or the most recent version).
	RX blinks yellow	Blinks at the data transfer rate when the unit receives data from other devices on the link  <b>ON solid yellow;</b> indicates there is reverse polarity	
	LED is not lit	Indicates that the controller is not detecting communication  <b>Not lit;</b> cycle the power to reestablish communication	
Service	Shows solid green when the LED has been pressed		When the UC400-B is placed into boot mode, the system will not run any applications such as trending, scheduling, and TGP2 runtime. The controller will be placed into boot mode if the service pin is held in when power is applied. In boot mode, the controller is non-operational and is waiting for a new main application to be downloaded.
	LED not lit	Indicates controller is operating normally	
Binary B01 through B09	Shows solid yellow	Indicates a corresponding binary output has been <b>commanded ON</b>  <b>Relay coil;</b> indicates that a command has been made to energize <b>TRIAC;</b> indicates that a command has been made to turn ON	If the user is currently powering the UC400-B from a USB port, the Led lights will turn <b>ON</b> . However, the binary outputs <i>will not</i> be activated. <b>Commanded ON;</b> As an example of commanded ON, a command could be a manual command such as an override or a command could be from TGP2 based on a list of conditions that are met telling these outputs to turn ON. LED not lit: Did the user command it to be ON? If yes, see the Marquee LED at the top of this table. For more information, refer to <i>Installation, Operation, and Maintenance: Tracer<sup>®</sup> UC400 Programmable Controller</i> (BAS-SVX20*-EN).
	LED not lit	Indicates that a relay output is de-energized or no power to the board  <b>Not lit;</b> cycle power to reestablish communication	

## Overriding Outputs

Analog and multistate value request points are included in order to safely override outputs without disrupting TGP2 program operation. To override valves and dampers for commissioning or testing purposes, access the following points on the Tracer<sup>®</sup> TU analog or multistate status pages:

- Cool valve request
- DX cool request
- Heat valve request
- Electric heat request
- Economizer request
- Supply fan speed active

For more information, refer to: BAS-SVX20C-EN Installation, Operation, and Maintenance: Tracer<sup>®</sup> UC400-B Programmable Controller

## Diagnostics

Diagnostics are informational messages that indicate the operational status of the controller. In response to most diagnostics, the controller attempts to protect the equipment by enabling/disabling, or by opening/closing specific outputs. Other diagnostics provide information about the status of the controller, but have no effect on outputs. Diagnostics are reported in the order in which they occur. Multiple diagnostics can be present simultaneously. Diagnostic messages are viewed using the Tracer<sup>®</sup> TU service tool or through a BAS.

**Note:** *Tracer<sup>®</sup> TU will report only active diagnostics.*

## Diagnostics Types

Diagnostics are categorized according to the type of clearing method each uses and the type of information each provides.

The diagnostic types are:

- Manual (latching) diagnostics
- Automatic (non-latching) diagnostics
- Smart reset diagnostics
- Informational diagnostics

**Note:** *Clearing diagnostics refers to deleting diagnostics from the software; it does not affect the problem that generated the message.*

## Manual (Latching) Diagnostics

Manual diagnostics (also referred to as latching) cause the unit to shut down. Manual diagnostics can be cleared from the UC400-B controller in one of the following ways:

- By using the Tracer<sup>®</sup> TU service tool to reset latching diagnostics on the **Alarms Status** tab or by temporarily overriding the **Reset Diagnostic Request** (bv/2) on the **Binary Status** tab.
- Through a building automation system.

- By cycling power to the controller. When the 24 Vac power to the controller is cycled **OFF** and then **ON** again, a power-up sequence occurs.

## Automatic (Non-latching) Diagnostics

Automatic diagnostics clear automatically when the problem that generated the diagnostic is solved.

## Smart Reset Diagnostics

Smart Reset Diagnostics are latching diagnostics that will auto-recover if the condition is corrected. After the controller detects the first smart reset diagnostic, the unit waits 30 minutes before initiating the smart reset function. If another diagnostic of this type occurs again within 24 hours after an automatic clearing, clear the diagnostic manually.

## Informational Diagnostics

Informational diagnostics provide information about the status of the controller. They *do not* affect machine operation, but can be cleared from the controller using the BAS or Tracer<sup>®</sup> SC.

## Building Automation System

Some building automation systems can reset diagnostics in the controller. For more complete information, refer to the product literature for the building automation system.

## Trane Service Tools

Tracer<sup>®</sup> TU can be used to reset diagnostics present in a Tracer<sup>®</sup> UC400-B controller.

## Controller Diagnostics

The following table lists each diagnostic that can be generated by the UC400-B controller, the diagnostic effect on outputs (*consequences*), and diagnostic type.

**Note:** *The generic binary output is unaffected by diagnostics.*

## Diagnostics and Troubleshooting

**Table 74. Diagnostics generated by UC400-B0 controller**

Diagnostic	Probable Cause	Consequences	Diagnostic Type
Filter change required	Fan run hours exceed the time set to indicate filter change.	<ul style="list-style-type: none"> <li>Fan <b>Unaffected</b></li> <li>Valves <b>Unaffected</b></li> <li>Electric heat <b>Unaffected</b></li> </ul>	Informational
Condensate overflow	The drain pan is full of water.	<ul style="list-style-type: none"> <li>Fan <b>OFF</b></li> <li>Valves <b>Closed</b></li> <li>Outdoor air damper <b>Closed</b></li> <li>DX/electric heat <b>OFF</b></li> </ul>	Manual
Low coil temp detection	The leaving fluid temperature may be close to freezing.	<ul style="list-style-type: none"> <li>Fan <b>OFF</b></li> <li>Valves <b>Open</b></li> <li>Outdoor air damper <b>Closed</b></li> <li>DX/electric heat <b>OFF</b></li> </ul>	Smart reset/Manual
Low airflow supply fan failure	The fan drive belt, contactor, or motor has failed.	<ul style="list-style-type: none"> <li>Fan <b>OFF</b></li> <li>Valves <b>Closed</b></li> <li>Outdoor air damper <b>Closed</b></li> <li>DX/electric heat <b>OFF</b></li> </ul>	Manual
Space temperature failure <sup>1</sup>	Invalid or missing value for zone temperature.	<ul style="list-style-type: none"> <li>Discharge air temperature control runs</li> <li>Unit shuts <b>OFF</b> if both space temperature and discharge air temperature fail</li> </ul>	Automatic
Entering water temp failure	Invalid or missing value for zone temperature.	<ul style="list-style-type: none"> <li>Fan <b>Unaffected</b> (enabled)</li> <li>Valves <b>Unaffected</b></li> <li>Outdoor air damper <b>Unaffected</b></li> <li>DX/electric heat <b>Unaffected</b></li> </ul>	Automatic
Discharge air temp low limit	Discharge air temperature has fallen below the Discharge Air Temperature Low Limit.	<ul style="list-style-type: none"> <li>Fan <b>OFF</b></li> <li>Valves <b>Open</b></li> <li>Outdoor air damper <b>Closed</b></li> <li>DX/electric heat <b>OFF</b></li> </ul>	Smart reset/manual
Discharge air temp failure <sup>1</sup>	Invalid or missing value for discharge air temperature.	<ul style="list-style-type: none"> <li>Simplified zone control algorithm runs</li> <li>Unit shuts OFF if zone temperature fails</li> </ul>	Automatic
Outdoor air temp failure	Invalid or missing value for outdoor air temperature.	<ul style="list-style-type: none"> <li>Fan <b>Unaffected</b></li> <li>Valves <b>Unaffected</b></li> <li>Outdoor air damper <b>Minimum Position</b></li> <li>DX cooling/electric heat <b>unaffected</b></li> </ul>	Automatic
Humidity input failure	Invalid or missing value for relative humidity.	<ul style="list-style-type: none"> <li>Fan <b>Unaffected</b></li> <li>Valves <b>Unaffected</b></li> <li>Outdoor air damper <b>Unaffected</b></li> <li>DX cooling/electric heat <b>Unaffected</b></li> </ul>	Automatic
CO <sub>2</sub> sensor failure	Invalid or missing value for CO <sub>2</sub> .	<ul style="list-style-type: none"> <li>Fan <b>Unaffected</b></li> <li>Valves <b>Unaffected</b></li> <li>Outdoor air damper <b>Unaffected</b></li> <li>DX cooling/electric heat <b>Unaffected</b></li> </ul>	Informational
Generic AIP failure	Invalid or missing value for generic analog input.	<ul style="list-style-type: none"> <li>Fan <b>Unaffected</b></li> <li>Valves <b>Unaffected</b></li> <li>Outdoor air damper <b>Unaffected</b></li> <li>DX cooling/electric heat <b>Unaffected</b></li> </ul>	Informational
Local fan mode failure	Invalid or missing fan-speed switch ( <i>reverts to default fan speed</i> ).	<ul style="list-style-type: none"> <li>Fan <b>Unaffected</b></li> <li>Valves <b>Unaffected</b></li> <li>Outdoor air damper <b>Unaffected</b></li> <li>DX cooling/electric heat <b>Unaffected</b></li> </ul>	Automatic
Local setpoint failure	Invalid or missing value for zone temperature setpoint ( <i>reverts to default setpoint</i> ).	<ul style="list-style-type: none"> <li>Fan <b>Unaffected</b></li> <li>Valves <b>Unaffected</b></li> <li>Outdoor air damper <b>Unaffected</b></li> <li>DX cooling/electric heat <b>Unaffected</b></li> </ul>	Automatic

**Note:** <sup>1</sup>For detailed information about zone temperature control methods, refer to "Zone Temperature Control," p. 94

### Fans with UC400-B Controller

**Table 75. Fan does not energize**

Probable Cause	Explanation
Unit wiring	The wiring between the controller outputs and the fan relays and contacts must be present and correct for normal fan operation. Refer to applicable wiring diagram.
Failed end device	The fan motor and relay must be checked to ensure proper operation.
Normal operation	The fan will turn <b>OFF</b> when: <ul style="list-style-type: none"> <li>The controller receives a communicated off signal</li> <li>The fan-speed switch is set to <b>OFF</b> if no communicated value is present</li> <li>Specific diagnostics are generated</li> <li>The default fan speed is set to <b>OFF</b> and the fan is operating in the Auto mode.</li> </ul> If the controller is in unoccupied mode, the fan cycles between <b>OFF</b> and the highest fan speed.
No power to the controller	If the controller does not have power, the unit fan does not operate. For the controller to operate normally, it must have an input voltage of 24 Vac. If the Marquee/Power LED is <b>OFF</b> continuously, the controller does not have sufficient power or has failed.
Diagnostic present	Several diagnostics affect fan operation. For detailed information about these diagnostics, refer to <a href="#">Table 74, p. 124</a> .
Unit configuration	The controller must be properly configured based on the actual installed end devices and application. If the unit configuration does not match the actual end device, the fans may not work correctly.
Random start observed	After power-up, the controller always observes a random start from 5 to 30 seconds. The controller remains <b>OFF</b> until the random start time expires.
Cycling fan operation/continuous	The controller continuously operates the fan when in the occupied, occupied standby, or occupied bypass mode. When the controller is in the unoccupied mode, the fan is cycled between high speed and <b>OFF</b> with capacity.
Unoccupied operation	Even if the controller is configured for continuous fan operation, the fan normally cycles with capacity during unoccupied mode. While unoccupied, the fan cycles <b>ON</b> or <b>OFF</b> with heating/cooling to provide varying amounts of heating or cooling to the space.
Fan mode off	If a local fan mode switch determines the fan operation, the <b>OFF</b> position controls the fan to off.
Requested mode off	The user can communicate a desired operating mode ( <i>such as OFF, heat, and cool</i> ) to the controller. If <b>OFF</b> is communicated to the controller, the unit controls the fan to off. There is no heating or cooling.

### Valves with UC400-B Controller

**Table 76. Valves remain closed**

Probable Cause	Explanation
Unit wiring	The wiring between the controller outputs and the valve(s) must be present and correct for normal valve operation. Refer to applicable wiring diagram.
Failed end device	The valves must be checked to ensure proper operation.
No power to the controller	If the controller does not have power, the unit valve(s) will not operate. For the controller to operate normally, apply an input voltage of 24 Vac. If the Marquee/Power LED is <b>OFF</b> continuously, the controller does not have sufficient power or has failed.
Diagnostic present	Several diagnostics affect valve operation. For detailed information about these diagnostics, refer to <a href="#">Table 74, p. 124</a> .
Normal operation	The controller opens and closes the valves to meet the unit capacity requirements.
Unit configuration	The controller must be properly configured based on the actual installed end devices and application. If the unit configuration does not match the actual end device, the valves may not work correctly.
Random start observed	After power-up, the controller always observes a random start from 5 to 30 seconds. The controller remains <b>OFF</b> until the random start time expires.
Requested mode off	The user can communicate a desired operating mode ( <i>such as OFF, heat, and cool</i> ) to the controller. If <b>OFF</b> is communicated to the controller, the unit controls the fan to off. There is no heating or cooling.
Entering water temperature sampling logic	The controller includes entering water temperature sampling logic, which is automatically initiated during 2-pipe and 4-pipe changeover, if the entering water temperature is either too cool or too hot for the desired heating or cooling.
Valve configuration	Ensure the valves are correctly configured, using the Tracer® TU service tool, as normally open or normally closed as dictated by the application. For modulating valves, ensure the stroke time is set correctly. Refer to <a href="#">Table 16, p. 27</a> .

## Diagnostics and Troubleshooting

**Table 77. Valves remain open**

Probable Cause	Explanation
Unit wiring	The wiring between the controller outputs and the valve(s) must be present and correct for normal valve operation. Refer to applicable wiring diagram.
Failed end device	The valves must be checked to ensure proper operations.
Normal operation	The controller opens and closes the valves to meet the unit capacity requirements.
Diagnostic present	Several diagnostics affect valve operation. For detailed information about these diagnostics, refer to <a href="#">Table 74, p. 124</a> .
Unit configuration	The controller must be properly configured based on the actual installed end devices and application. If the unit configuration does not match the actual end device, the valves may not work correctly.
Entering water temperature sampling logic	The controller includes entering water temperature sampling logic, which is automatically initiated during 2-pipe and 4-pipe changeover, if the entering water temperature is either too cool or too hot for the desired heating or cooling.
Valve configuration	Ensure the valves are correctly configured, using the Tracer® TU service tool, as normally open (NO) or normally closed (NC) as dictated by the application. For modulating valves, ensure the stroke time is set correctly. Refer to <a href="#">Table 16, p. 27</a> .
Freeze avoidance	When the fan is <b>OFF</b> with no demand for capacity (0%), and the outdoor air temperature is below the freeze avoidance setpoint, the controller opens the water valves (100%) to prevent coil freezing. This includes unoccupied mode when there is no call for capacity or any other time the fan is <b>OFF</b> .

## DX Coils or Electric Heat with UC400-B Controller

**Table 78. DX or electric heat does not energize**

Probable Cause	Explanation
Unit wiring	The wiring between the controller outputs and the end devices must be present and correct for normal operation. Refer to applicable wiring diagram.
Failed end device	Check the control contactors or the electric heat element, including any auxiliary safety interlocks, to ensure proper operation.
No power to the controller	If the controller does not have power, heat outputs do not operate. For the controller to operate normally, apply an input voltage of 24 Vac. If the Marquee/Power LED is <b>OFF</b> continuously, the controller does not have sufficient power or has failed.
Diagnostic present	Several diagnostics affect DX and electric heat operation. For detailed information about these diagnostics, refer to <a href="#">Table 74, p. 124</a> .
Normal operation	The controller controls compressor or electric heat outputs as needed to meet the unit capacity requirements.
Unit configuration	The controller must be properly configured based on the actual installed end devices and application. If the unit configuration does not match the actual end device, DX or electric heat may not operate correctly.
Requested mode off	The user can communicate a desired operating mode (such as <b>OFF</b> , heat, and cool) to the controller. If <b>OFF</b> is communicated to the controller, the unit shuts off the compressor or electric heat.
Freeze avoidance	When the fan is <b>OFF</b> with no demand for capacity (0%), and the outdoor air temperature is below the freeze avoidance setpoint, the controller disables compressors and electric heat outputs (100%) to prevent coil freezing. This includes unoccupied mode when there is no call for capacity or any other time the fan is <b>OFF</b> .

## Outdoor Air Dampers with UC400-B Controller

**Table 79. Outdoor air damper remains closed**

Probable Cause	Explanation
Unit wiring	The wiring between the controller outputs and the outdoor air damper must be present and correct for normal outdoor air damper operation. Refer to applicable wiring diagram.
Failed end device	Check damper actuator to ensure proper operation.
No power to the controller	If the controller does not have power, the outdoor air damper does not operate. For the controller to operate normally, apply an input voltage of 24 Vac. If the Marquee/Power LED is <b>OFF</b> continuously, the controller does not have sufficient power or has failed.
Diagnostic present	Several diagnostics affect outdoor air damper operation. For detailed information about these diagnostics, refer to <a href="#">Table 74, p. 124</a> .
Normal operation	The controller opens and closes the outdoor air damper based on the controller's occupancy mode and fan status. Normally, the outdoor air damper is open during occupied mode when the fan is running and closed during unoccupied mode.
Unit configuration	The controller must be properly configured based on the actual installed end devices and application. If the unit configuration does not match the actual end device, the outdoor air damper may not work correctly.
Warm-up and cool-down sequence	The controller includes both a morning warm-up and cool-down sequence to keep the outdoor air damper closed during the transition from unoccupied to occupied. This is an attempt to bring the space under control as quickly as possible.
Requested mode off	The user can communicate a desired operating mode (such as <b>OFF</b> , heat, or cool) to the controller. If <b>OFF</b> is communicated to the controller, the unit closes the outdoor air damper.

**Table 80. Outdoor air damper remains open**

Probable Cause	Explanation
Unit wiring	The wiring between the controller outputs and the outdoor air damper must be present and correct for normal outdoor air damper operation. Refer to applicable wiring diagram.
Failed end device	Check damper actuator to ensure proper operation.
Normal operation	The controller opens and closes the outdoor air damper based on the controller occupancy mode and fan status. Normally, the outdoor air damper is open during occupied mode when the fan is running and closed during unoccupied mode. (Refer to the section, " <a href="#">Modulating Outdoor/Return Air Damper</a> ," p. 97.)
Unit configuration	The controller must be properly configured based on the actual installed end devices and application. If the unit configuration does not match the actual end device, the outdoor air damper may not work correctly.

## ECM Motors

### **⚠ WARNING**

#### **Hazardous Voltage w/Capacitors!**

Failure to disconnect power and discharge capacitors before servicing could result in death or serious injury. Disconnect all electric power, including remote disconnects and discharge all motor start/run capacitors before servicing. Follow proper lockout/tagout procedures to ensure the power cannot be inadvertently energized. For variable frequency drives or other energy storing components provided by Trane or others, refer to the appropriate manufacturer's literature for allowable waiting periods for discharge of capacitors. Verify with an appropriate voltmeter that all capacitors have discharged.

For additional information regarding the safe discharge of capacitors, see PROD-SVB06A-EN

An electronically commutated motors (ECM) is a closed loop system that has equipment protections and envelope enforcements. Do not assume that the motor has failed without first consulting the VelociTach engine status/diagnostics screen. In many cases, the engine shuts down the motor operation and locks it out to prevent equipment damage.

Electric heat operation and changeover coil control on CSTI units are coordinated by the VelociTach motor control board. Changeover function on Tracer<sup>®</sup> ZN units can also be affected by incorrect configuration of the VelociTach motor control board or improper wiring of terminals to analog input 1 on the Tracer<sup>®</sup> ZN controller (polarity sensitivity).

The mini-access lid on the front of the main control panel lid has the VelociTach troubleshooting/setup guide affixed to the back of the lid. This guide is unit-specific and should be consulted before determining the disposition of a unit.

The adapter boards contain high voltage. Configuration adjustments to the VelociTach board should be made through the SMALLER of the two low-voltage lids on the front of the control panel, through the low-voltage insulation/shielding.

### **⚠ WARNING**

#### **Hazardous Voltage!**

Failure to disconnect power before servicing could result in death or serious injury. Disconnect all electric power, including remote disconnects before servicing. Follow proper lockout/tagout procedures to ensure the power can not be inadvertently energized.

### General Information

The VelociTach motor control board oversees and monitors all motor operations and changes to speed resulting from:

- Direct fan speed requests
  - Customer fan speed switches
  - Thermostat fan speed, On or 0–10V requests
  - Automatic fan request from Tracer<sup>®</sup> controllers
- Indirect fan speed requests
  - Electric heat requests will bring the fan to the proper speed.
- Conflicting fan speed requests
  - If two or more commands are received (direct or indirect), the fan will honor the higher speed requested.

**Note:** In some cases, indirect requests will result in fan behavior change regardless of whether the end-device fails to actuate (due to device failure, or safety/down-stream lockouts).

The VelociTach motor control board also coordinates the operation of electric heat, electric/hydronic heat lockouts, and CSTI changeover coil operation.

### Troubleshooting Tips

- VelociTach motor control board configuration must perfectly match the factory-supplied ECM.
  - Refer to “Adjustments,” p. 73 for configuration of the motor control board.
- The VelociTach motor control board will display troubleshooting information, and contains dual tachometers to aid in performance verification.
- Under normal circumstances, the VelociTach display will display the operational status of the motors and electric heat circuit/sensors, however, a malfunction will drive a priority display mode that will present the error code instantly to the screen. The error must be cleared by solving by powering down, removing the cause of the problem and restarting the engine board.
- VelociTach label (see ECM Setup chapter) setup document (affixed to the back of the low voltage access lid) should be used to verify engine configuration settings.
- For proper operation of the system, all plugs must be firmly seated in all boards and motors. Insecure connections will cause malfunction and the system will shutdown.
- Do not unplug or plug-in motors or connectors while the system is receiving a speed request of any kind. The system must be powered down before plugging or un-plugging connections to the adapter boards, engine boards or motors. Failure do so will register diagnostics or cause unsafe operation and reduction in the contact life of the connectors.
- The motor will not spin if plugged in while the ECM engine is requesting power.

### Motor

The motor connections and motor plug connections to the adapter boards should be secure. Unit should be powered off to check the fit of the connectors.

When configured correctly, the system will always respond positively to direct, indirect, and conflicting speed requests with very few exceptions.

**Table 81. Motor does not spin, spins too slowly**

Situation	Probable Cause	Solution
Motor has been locked out due to engine locked rotor protection	Motor 1 has an obstruction. "Status Display" will be interrupted to display: <b>LOCH → Mtr 1 → LrPt</b>	<ul style="list-style-type: none"> <li>Remove obstruction from the fan wheel.</li> <li>Ensure that motor plugs and all plugs to adapter boards and the ECM engine board are secure</li> <li>Verify that the configuration does not specify a motor that is physically missing. Most units require only one motor. The controller is made aware of the missing motor by specifying all speeds related to Motor 2 to 0 rpm.</li> <li>Verify that <b>M1Lo</b> and <b>M2Lo</b>, the low motor signal output limits, are set correctly.</li> </ul>
Motor has been locked out due to overspeed or runaway condition	Motor 1 has an overspeed condition. The "Status Display" will be interrupted to display: <b>OSPd → Mtr 1 → OSPd</b>	<ul style="list-style-type: none"> <li>Ensure that set-screw is attached firmly to the motor shaft.</li> <li>Ensure that motor plugs and all plugs to adapter boards and the ECM engine board are secure.</li> <li>Verify that the configuration does not specify a speed lower than 450 rpm for the affected motor. Speeds below 450 rpm are not supported on fan-coil units.</li> </ul>
VSP Inputs (0–10V inputs) are of the wrong polarity	Variable speed (VSP) inputs may not be properly wired to 1TB4	<ul style="list-style-type: none"> <li>Do not short the courtesy 10 VDC supply to chassis or loads that require greater than 10 mA of DC current.</li> <li>Observe proper polarity of 0–10 VDC inputs. Failure to observe proper polarity can cause failure of the VelociTach motor control board, the customer-supplied controller, or the Tracer<sup>®</sup> ZN controller.</li> </ul>
Customer Controller output signal to VSP Inputs are too low. <b>Note:</b> If the customer supplied controller outputs signals that are below the noise threshold, they will be ignored by the ECM Engine.	Noise floor is set too high.	<ul style="list-style-type: none"> <li>The VelociTach motor control board contains an adjustable noise floor parameter, <b>UPLR</b> that can be configured to reject signals below the noise floor.</li> <li>The noise floor parameter is set too high, it can be lowered as long as there are acceptable noise levels on the inputs lines.</li> </ul>

Typical equipment and controls design practice will ensure that the fans will come on if there is a call for heat, cool, or ventilation. In most cases, we will depend on the controller/thermostat to call for the fan to come on when appropriate, but during calls for electric heat, or calls for heat on CSTI units equipped with electric heat, as a call for the appropriate fan speed. This behavior, as described previously, is an indirect request.

When a call for electric heat is made, the system will positively drive the fan on to the correct speed, regardless of whether the controller has asked for fan operation or not. The unit design incorporates an interlock instead of a lock-out. (It does not lock out electric heat if the fan is set to off; it brings the fan on.)

**Notes:** In many cases, indirect requests will result in fan behavior change regardless of whether the end-device fails to actuate (due to device failure, or safety/down-stream lockouts). If there is hot water available on CSTI units with changeover coils and electric heat, we will still drive the fan to the appropriate electric heat speed.

**Notes:** The new fan coil designs incorporate sophisticated fan interlocks that will lockout heat if there is a fan failure.

If the preceding conditions do not describe the behavior of the unit, the following checks should be performed:

**Table 82. Motor spins too fast or spins without any apparent speed request**

Situation	Probable Cause
Motor not controllable	Verify that the voltage jumper on the motor plug harness is absent for 208-230V units and 277V units. If the jumper is present for these units, the motor electronics will be damaged, and the motor will not be controllable.
Fan speed request too low	Verify that the fan speed request is not below 450 rpm. Speeds below 450 rpm are not supported on the fan coil product.
Inputs not of consistent polarity	Verify that the all binary inputs to the customer terminal blocks are of proper and consistent polarity. <ul style="list-style-type: none"> <li>For CSTI units, the fan inputs and end device inputs on TB3 must receive signals that are 24 Vac with respect to the unit chassis.</li> <li>For Fan Speed Switch (FSS) units, that incorporate the Tracer® ZN/CSTI adapter board, all inputs to TB3 must be 24 Vac with respect to unit chassis.</li> <li>For Tracer® ZN units, where there is a desire to use parallel fan inputs on the adapter board TB3 strip, the inputs must be COM (i.e., the inputs will honor only 0 V with respect to unit chassis).</li> </ul> <b>Note:</b> Do not short 24 Vac (pos 1 or pos 2) to chassis; refer to the unit schematic.
Failure of motor control board	Verify that variable speed (VSP) inputs are properly wired to 1TB4. <ul style="list-style-type: none"> <li>Do not short the courtesy 10 VDC supply to chassis or loads that require greater than 10 mA of DC current.</li> <li>Please observe proper polarity of 0–10 VDC inputs. Failure to observe proper polarity can cause failure of the VelociTach motor control board, the customer-supplied controller or the Tracer® ZN controller.</li> </ul>
Output signals being ignored	Verify that the signal on the VSP inputs is noise free. The VelociTach motor control board contains an adjustable noise floor parameter, $uFLr$ , that can be configured to reject signals below the noise floor. <ul style="list-style-type: none"> <li>If the customer supplied controller outputs signals that are below the noise threshold, they will be ignored by the ECM engine.</li> </ul>
Motor spinning too fast	Verify that VSP input settings are correct. The motor control board board contains an adjustable digital amplifier, $AISC$ , to compensate for long 10 VDC cable runs. For normalized (0–10 VDC) signals, this setting should be set to 1.000. If it is set too high, the motors will run faster than the requested ratio, and will hit the limit $Ahit$ before the input voltage has reached its upper limit.
Motor not controllable	Verify that $iLo$ and $i2Lo$ , the low motor signal output limits, are set correctly.

### Replacing ECM Components

#### **⚠ WARNING**

#### **Hazardous Voltage w/Capacitors!**

**Failure to disconnect power and discharge capacitors before servicing could result in death or serious injury. Disconnect all electric power, including remote disconnects and discharge all motor start/run capacitors before servicing. Follow proper lockout/tagout procedures to ensure the power cannot be inadvertently energized. Verify with an appropriate voltmeter that all capacitors have discharged.**

*For additional information regarding the safe discharge of capacitors, see PROD-SVB06A-EN*

### Replacement Guidelines

- ECM motors contain capacitors which store residual energy. Please keep clear of the fan wheels for five minutes after the power has been removed from the system, as a power request with the motor powered off, could result in a very short period of actuation. Unplugging the motor is adequate to ensure that there will be no power request.
- Configuration adjustments to the VelociTach motor in accordance with the parameters that are printed on the label adjacent to the VelociTach board. These parameters reflect the factory settings for the unit. Subsequent changes to parameters made during commissioning will not be reflected in the printed parameters.
- Initial hookups to the CSTI and standard adapter board, including low voltage interconnections, must be made with the power off.
  - Do not make connections to the motors or the adapter boards while power is ON. Do not remove connections to the motor or the adapter boards while the power is ON.
  - Caution should be taken to stay clear of hazardous voltages, moving parts and electric heat elements while making adjustments to the VelociTach motor control board. If it is not practical to stay clear of these areas during adjustment, please contact Trane Global Parts for configuration kit that allows easy powering of the engine board outside of the unit with a 9V battery.
  - For safe operation, it is necessary to configure replacement boards to match the setup/switch configuration of the previously installed boards.
  - Ensure that new circuit modules are firmly seated on the nylon standoffs, and that the nylon standoffs are firmly seated on the metal panel
  - Ensure that drip-loops are maintained on wiring on pipe end of unit to avoid wicking of water into the unit.
  - Before assuming that any of the boards or components in the new system have failed, please ensure that the VelociTach motor control board has been configured correctly and that the switches on the CSTI board (where applicable) are set correctly.
  - It is necessary to configure the service replacement VelociTach motor control board before commissioning the unit. The board is pre-configured with safe values, but will NOT work correctly unless properly configured. The factory shipped parameter settings are on the label adjacent to the VelociTach.
  - Only genuine Trane replacement components with identical Trane part numbers should be used.

- Unit fan assemblies contain concealed wires that should be removed before the fan-board is removed, to avoid nicking the wire.
- Care should be maintained to retain the order of the motors with respect to the motor plugs. On a unit with two motors, the double-shafted motor will always be to the left side, and will be designated as Motor 2 by the controller.

### Replacement Checklist

#### NOTICE

#### Equipment Damage!

Failure to follow this instruction could result in equipment damage. The motor harness attached to the single plug to which the motor mates contains the very important 115V motor voltage jumper; the motor harness should always be present for 115V units and should not be modified or substituted.

- |  |
|--|
| <input type="checkbox"/> Ensure that motor nameplate voltage is the same as unit voltage (for 3-phase/ 4-wire units with Neutral, motor voltage will be L-N, not L1-L2). |
| <input type="checkbox"/> Ensure that motor harness is correct (harness will have jumper installed for 115V units only).  |
| <input type="checkbox"/> Ensure that configuration on the VelociTach motor control board matches the affixed label.  |
| <input type="checkbox"/> Maintain correct plug/motor association. The plugs will have the motor number and shaft configuration printed on an affixed label.              |
| <input type="checkbox"/> Ensure that configuration of switches on CSTI adapter board matches depiction of switches on the unit schematic.                                |
| <input type="checkbox"/> Ensure that all wires are plugged in securely.  |
| <input type="checkbox"/> Ensure that edge protection on sharp edges, grommets, and wire management devices are maintained when replacing components.                     |
| <input type="checkbox"/> Ensure that blunt-tip screws are used when in the proximity of wire harnesses.  |

### Circuit Module Replacement

1. Circuit modules are equipped with nylon standoffs which can either be removed by squeezing the barbs at the rear of the control panel, or squeezing the latch above the circuit module. If the latter method is chosen, the standoffs will be retained on the metal panel. The new standoffs (affixed to the replacement modules)

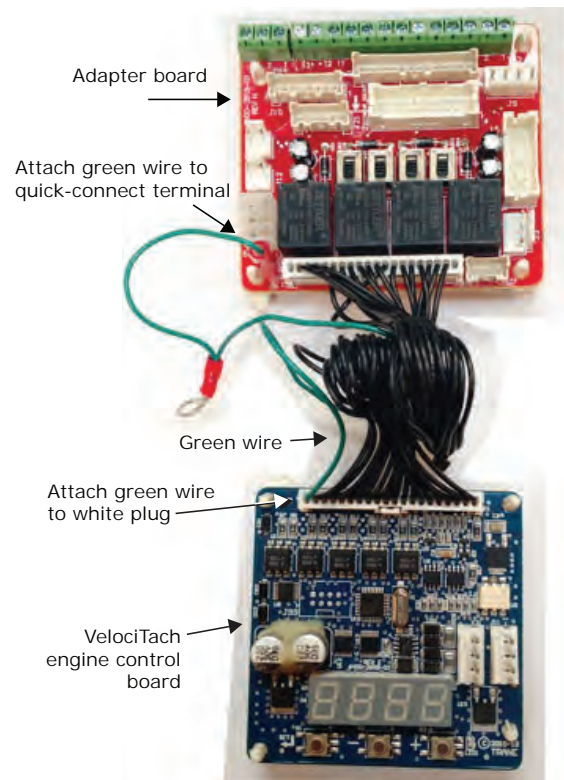
can be removed if necessary, so the new module circuit board can be attached to the retained standoffs.

Figure 98. Remove PCB



2. If replacing the VelociTach motor control board, special care should be taken to avoid electro-static discharge damage. Please use an ESD protection wrist-strap and frequently touch a grounded surface (with unit power off) to discharge any static buildup.
3. Replace connectors carefully onto the appropriate board. For units with a green wire attached to the CSTI or standard adapter boards, please **ensure that the green wire is attached to the engine board white connector** as shown in the following figure.

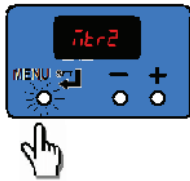
Figure 99. CSTI wiring



## Diagnostics and Troubleshooting

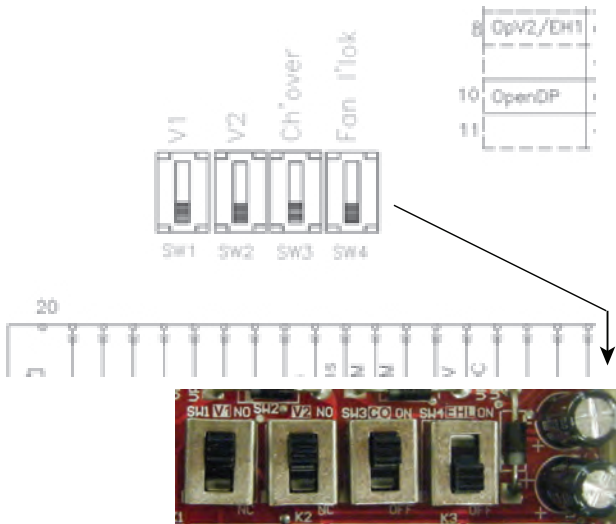
- Ensure that the new VelociTach motor board controller is configured to match the configuration label that is present on the unit. It is necessary to configure the VelociTach board to avoid improper operation of the unit, discomfort to the end user, and loud fan operation.

**Figure 100. Configure VelociTach board**



- Ensure that the CSTI adapter board switches are set correctly, as indicated in the unit schematic (where applicable) shown in the following figure.

**Figure 101. Ensure CSTI adapter board switches are set correctly**



- After replacing modules, commission the unit by performing at a minimum, "Fan Speed Response Verification," p. 80.

### Application Notes

The ECM motor has some notable differences to traditional designs.

#### RPM Mode

The motors are programmed from the factory to run in rpm mode and will not change rpm based on external static pressure, except at the performance limits of the motor/controller. The units are shipped with the rpm set to the selected value for High. The speeds can be changed for high, medium, and low operation, but should not be changed for the electric heat actuation speeds.

Generally, the fans deliver less cfm for the same rpm, if the static is increased and the power will decrease. The fan will deliver more cfm for the same rpm, if the static is decreased and the fan power will increase. A unit with high static configuration should not be used to free-deliver air (i.e., with no ducting attached).

### Field Power Wiring

This motor uses an electronic variable speed motor control, which includes a line reactor to minimize power line harmonic currents. It is recommended that good wiring practices be followed to manage building electrical power system harmonic voltages and currents to avoid electrical system problems or other equipment interaction.

### Performance Boundaries

While the speeds of the fan motors can be adjusted, never program a fan speed outside the operating limits for the given unit size. In many cases, units configured for high-static operation will not achieve the desired rpm if the ESP of the unit is too low, or the unit is allowed to "free-discharge." The VelociTach motor control board contains settings that will limit the output power of the motor under these overload conditions. If the motors cannot achieve rpm close to the target for a specific period of time, the unit will disable electric heat and fan-status indicators.

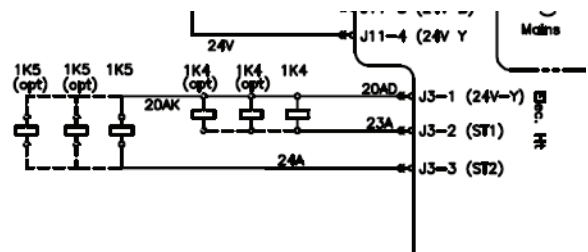
### MCA/MOP and Power Draw

ECM motors have variable output but are shipped at specific settings to deliver proper performance and reliability. The power draw indicated in the catalog indicates the power consumed when applied properly (as shipped and with the nominal ESP applied). However, the nameplate of the unit indicates the maximum input draw of the motor, as the motor settings can be changed to draw more power.

### Electric Heat Relays

For quiet operation, the new BLDC units employ power relays instead of definite purpose contactors for electric heat actuation. The coils of multiple relays are hooked in parallel to simulate a multi-pole contactor, as shown in the following figure. Two sets of three relays are used to perform the function of a two 3-pole contactors.

**Figure 102. Sample arrangement: electric heat relay**



### Troubleshooting Other Unit Functions

In some cases, the normal or abnormal operation of the ECM may interact with other components in the system. Generally, verification of the engine and adapter boards' wiring and configuration should be checked if there are unexplained abnormalities in other areas of the unit:

- Valve operation
- Electric heat operation
- Changeover sensor operation
- Damper operation
- Condensate overflow switch

A high degree of protection is provided on electric heat units. If electric heat fails to actuate, it may be because of one of the following events:

- Fans are failing to meet target speed. If a second motor is not present, all settings for speeds for Motor 2 should be set to 0000.
- Hot water may be available in the changeover coil.
- The connection to analogue input 1 on the Tracer<sup>®</sup> ZN controller may be reversed in polarity.
- Target speeds for motors may be set too high:
  - The **FPr** parameter may be set incorrectly.
  - The **R *i*PU** parameter may be set incorrectly.



# Wiring Diagrams

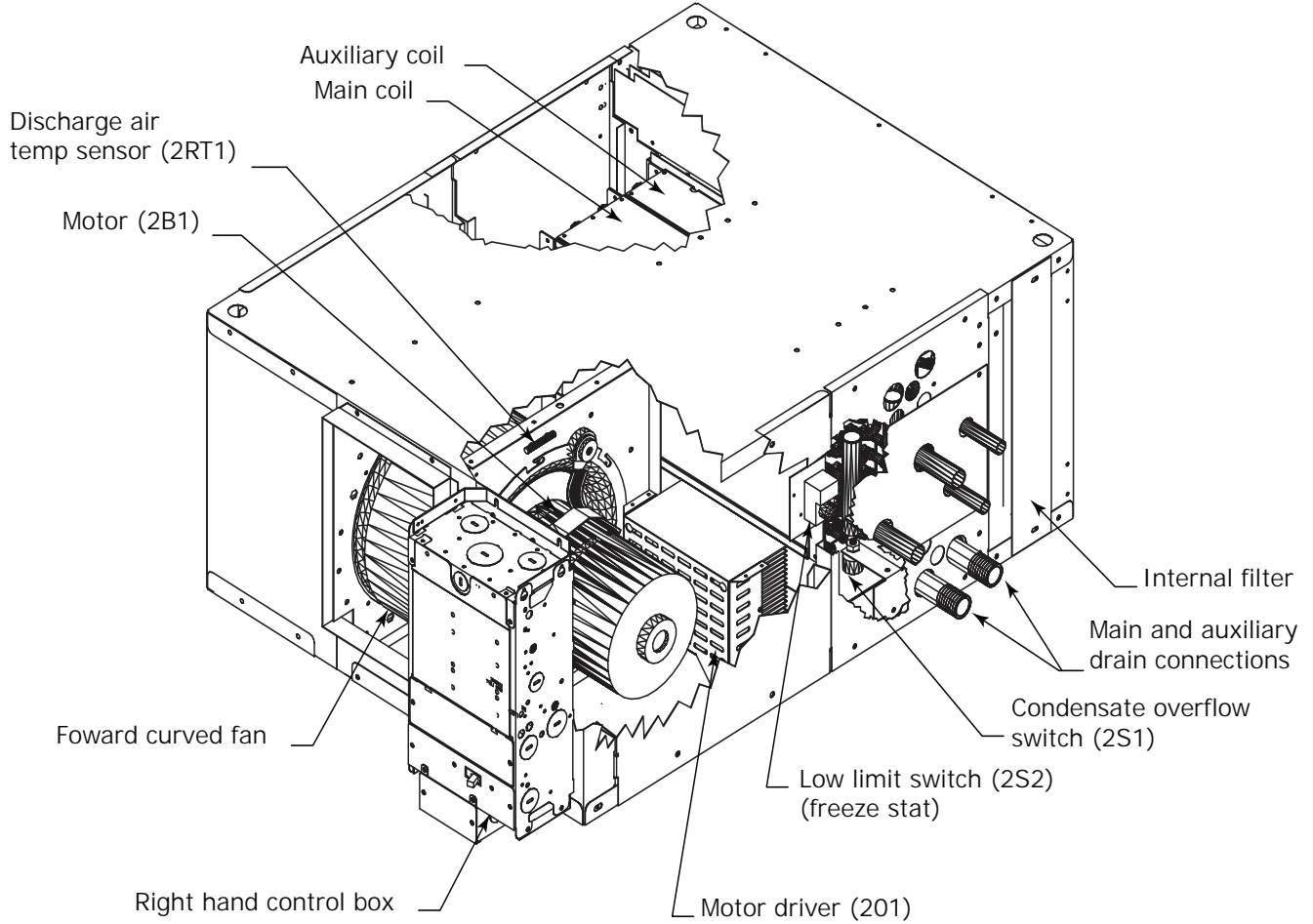
**Table 83. Wiring diagram matrix**

Number	Description
<b>Power</b>	
2311-3980	Power schematic, BCXD - ZN, CSTI and FSS
2311-4013	Power schematic, BCXD - UC400B
<b>Controls</b>	
2311-3989	Controls schematic, BCXD - CSTI with DX coil and 2 stage electric heat
2311-4017	Controls schematic, BCXD - No controls (FSS)
5026-1695	Controls schematic, BCXD - ZN520 with standard coils
5026-1696	Controls schematic, BCXD - ZN520 with DX coils
5026-1697	Controls schematic, BCXD - CSTI with standard coils
5026-1698	Controls schematic, BCXD - CSTI with DX coil and 1 stage electric or heating valve
5026-1699	Controls schematic, BCXD - UC400B with standard coils
5026-1700	Controls schematic, BCXD - UC400B with DX coils
5026-1701	Controls schematic, BCXD - ZN010 or ZN510 with standard coils
5026-2488	Controls schematic, BCCD - Wall mounted thermostat
5026-2489	Controls schematic, BCHD/BCVD - Wall mounted thermostat
<b>Zone Sensors and Dampers</b>	
2311-3984	Zone sensors and dampers, BCXD - ZN520
2311-4130	Zone sensors and dampers, BCXD - UC400B
<b>Component Layout</b>	
2311-3983	Component layout, BCXD

**Note:** Wiring diagrams can be accessed using e-Library by entering the diagram number in the literature order number search field or by contacting technical support.

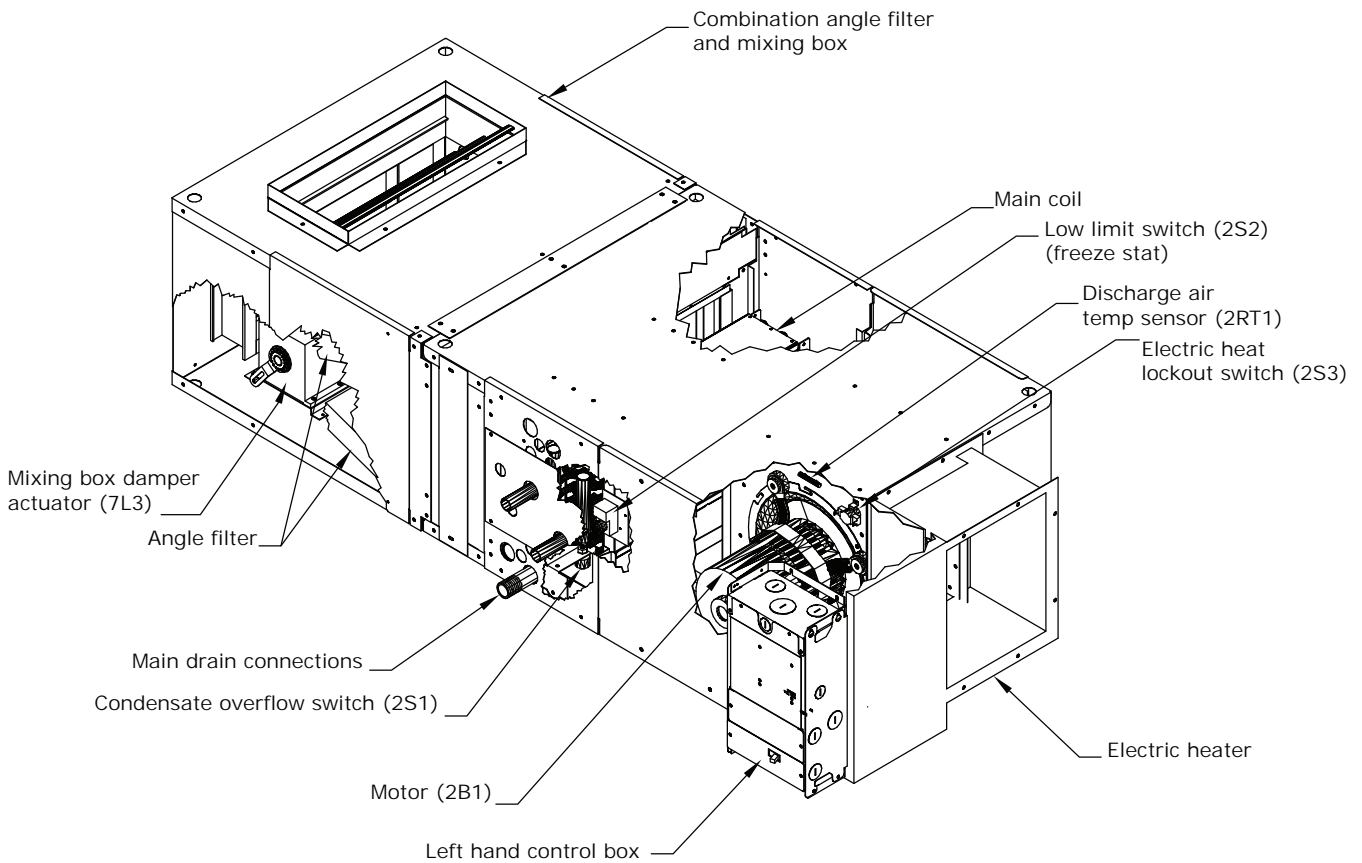
# Layout and Control Box Diagrams

**Figure 103. Right-hand control box with three-phase motor, three-phase driver, condensate overflow, low-limit switch, outside air temp, fan stat, discharge air temp, and humidity sensor**



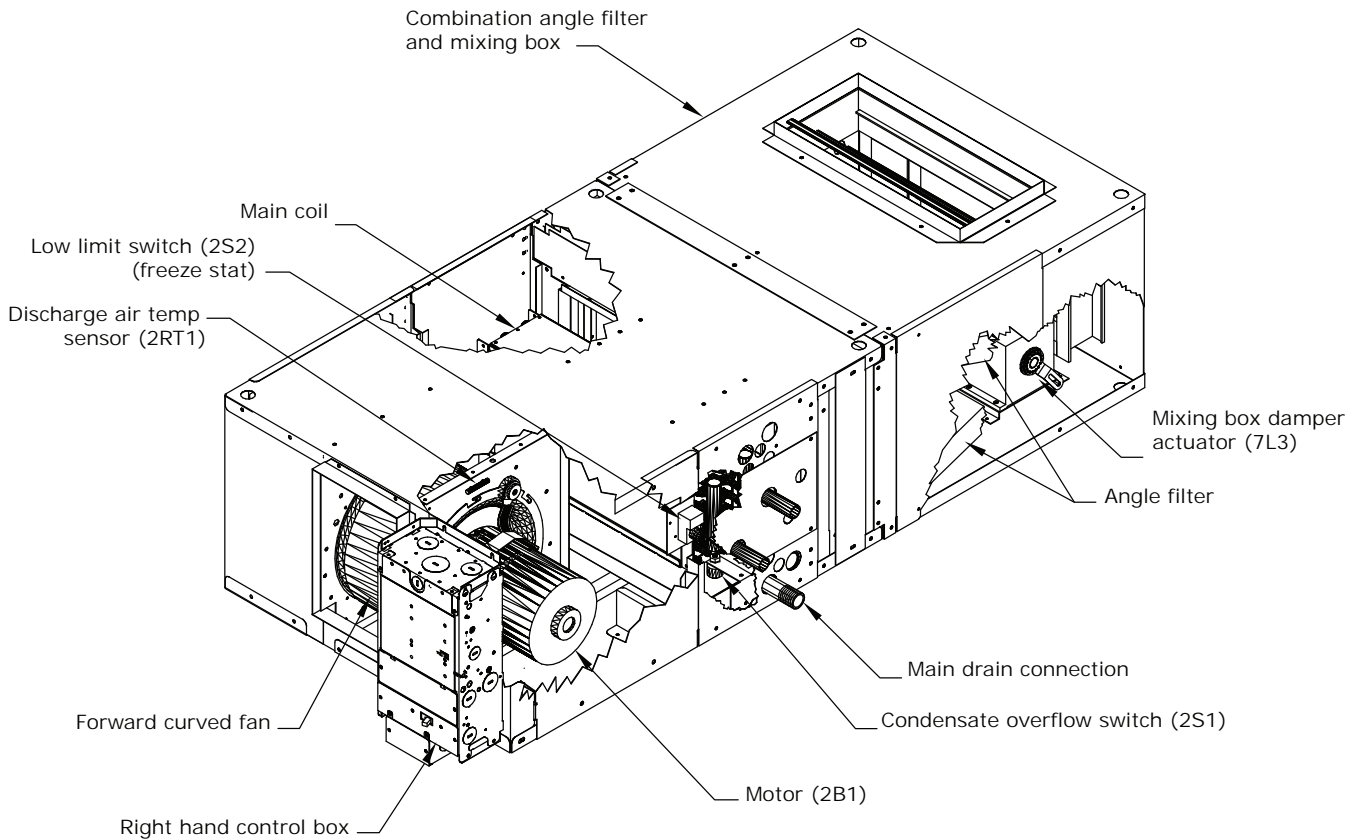
## Layout and Control Box Diagrams

**Figure 104. Left-hand control box with motor, electric heat, condensate overflow, low-limit switch, outside air temp, discharge air temp, and angle filter/mixing box actuator**



Outside air sensor located in outside air ductwork  
 Discharge air temp sensor field installed in ductwork

**Figure 105. Right-hand control box with motor, condensate overflow, low-limit switch, outside air temp, angle filter/mixing box actuator, and discharge air temp**

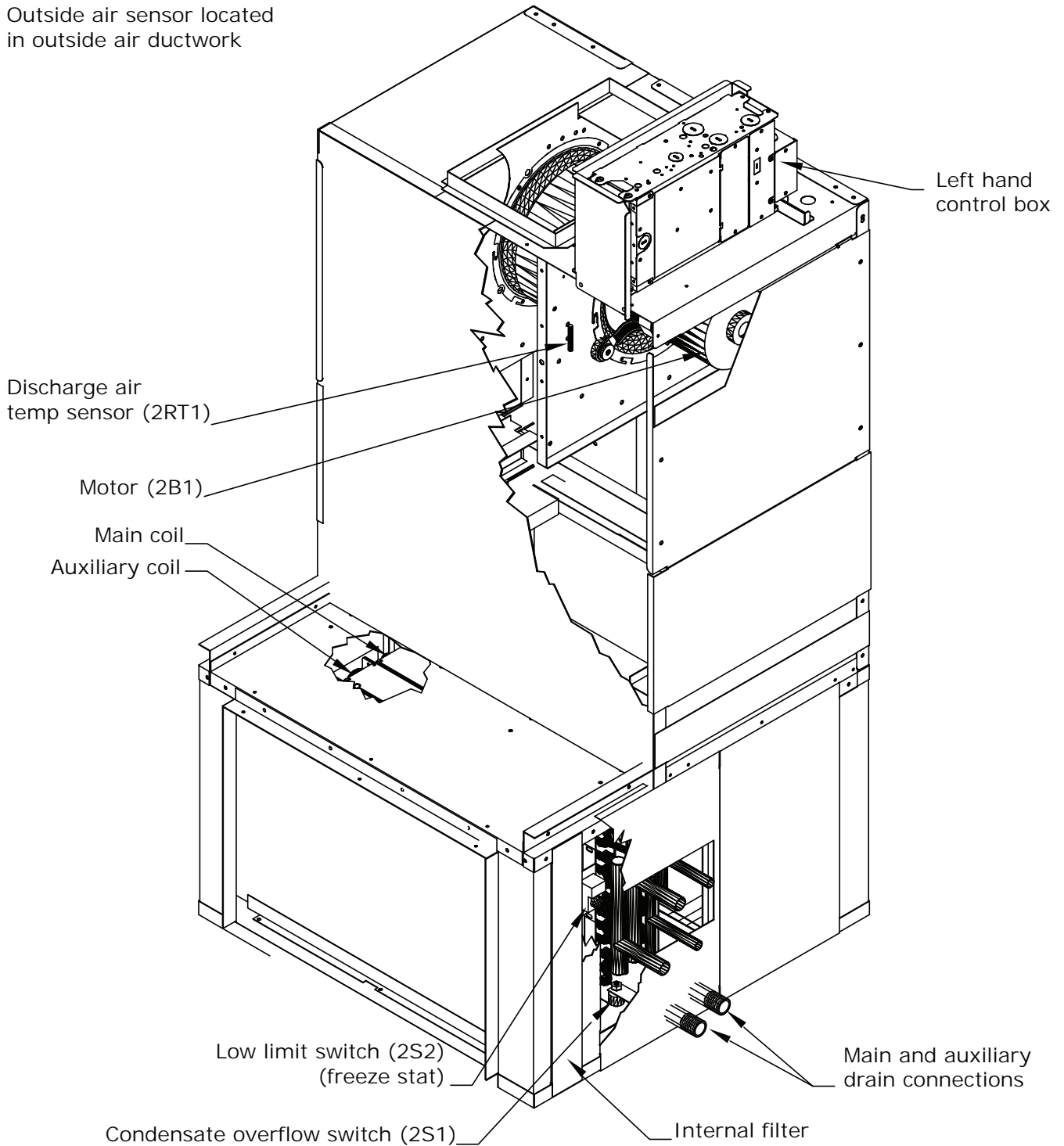


## Layout and Control Box Diagrams

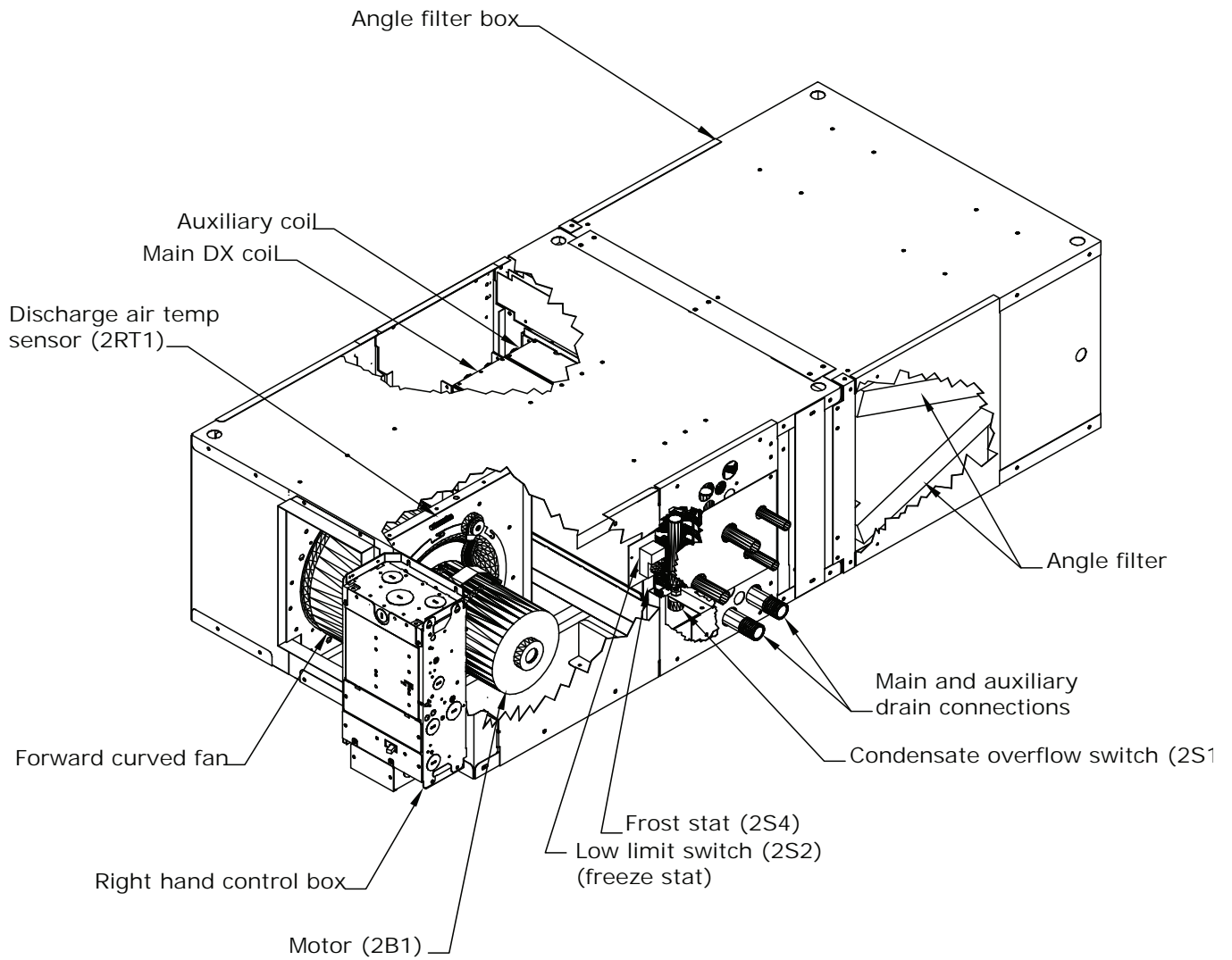
---

**Figure 106. Left-hand control box with motor, condensate overflow, low-limit switch, outside air temp, and discharge air temp**

Outside air sensor located  
in outside air ductwork



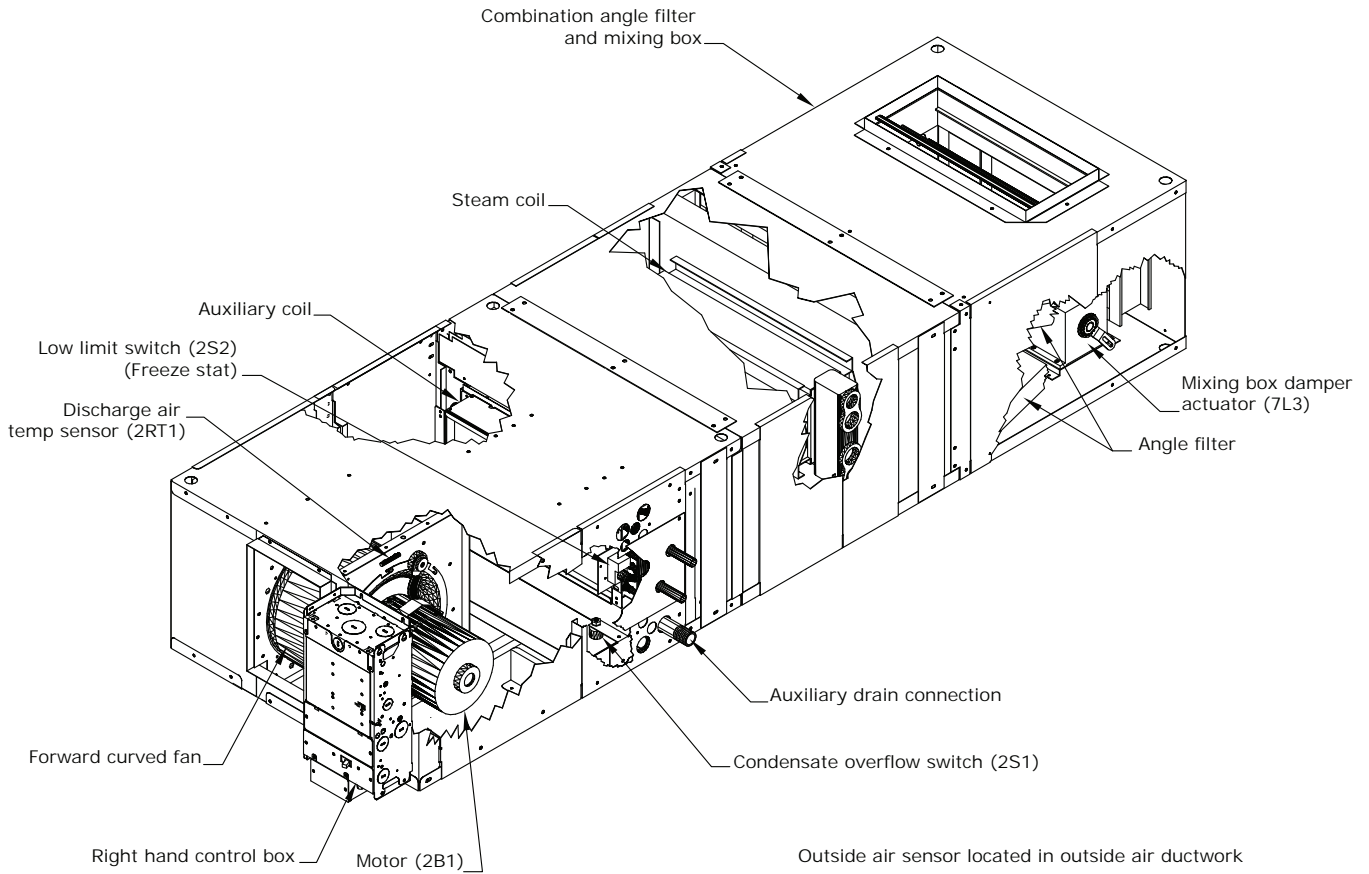
**Figure 107. Right-hand control box with motor, low-limit switch, froststat, outside air temp, angle filter section, and discharge air temp**



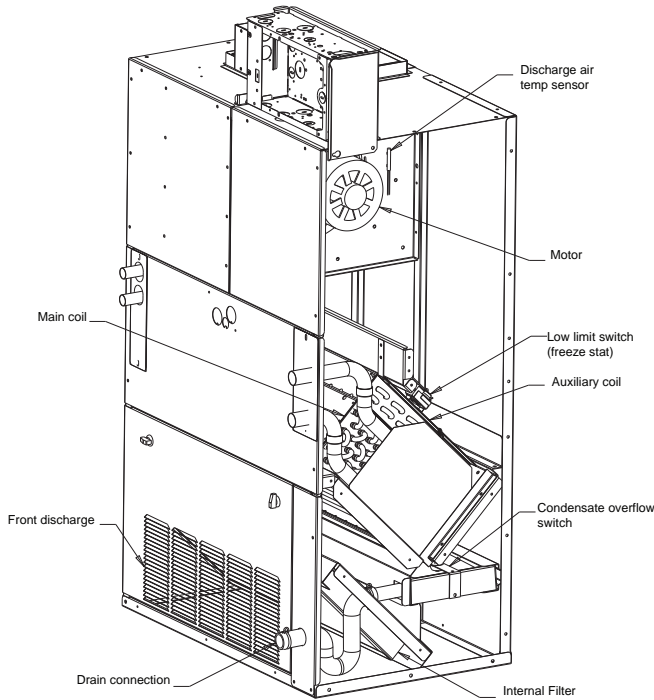
Outside air temp sensor remote mounted in outside air ductwork

## Layout and Control Box Diagrams

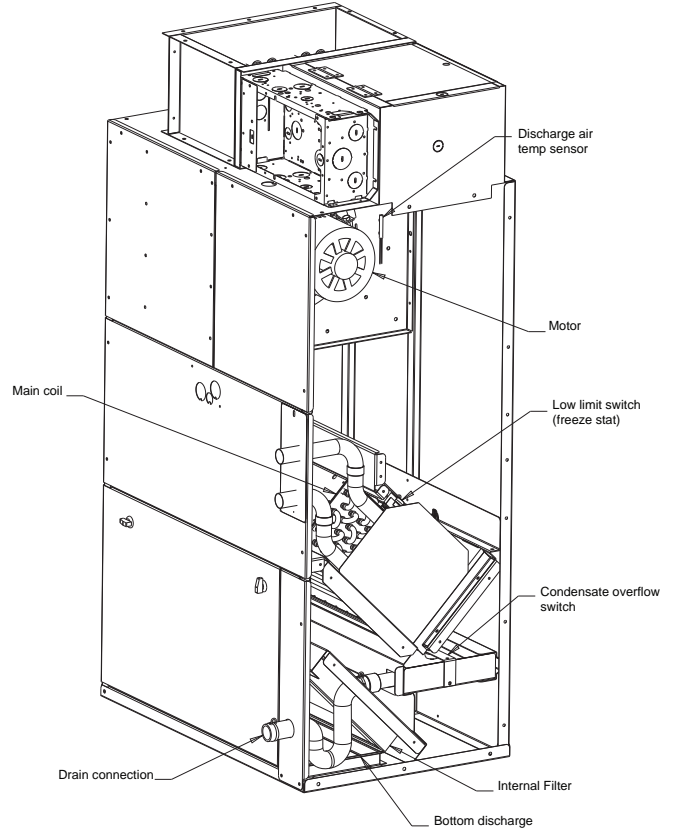
**Figure 108. Right-hand control box with motor, two-pipe cooling coil with modulating 2-way control valve, steam coil module with field-supplied 2-position valve/angle filter box/mixing box and actuator, low-limit switch, outside air temp, fan stat, and discharge air temp**



**Figure 109. BCCD unit with condensate overflow, low-limit switch, and discharge air temp**



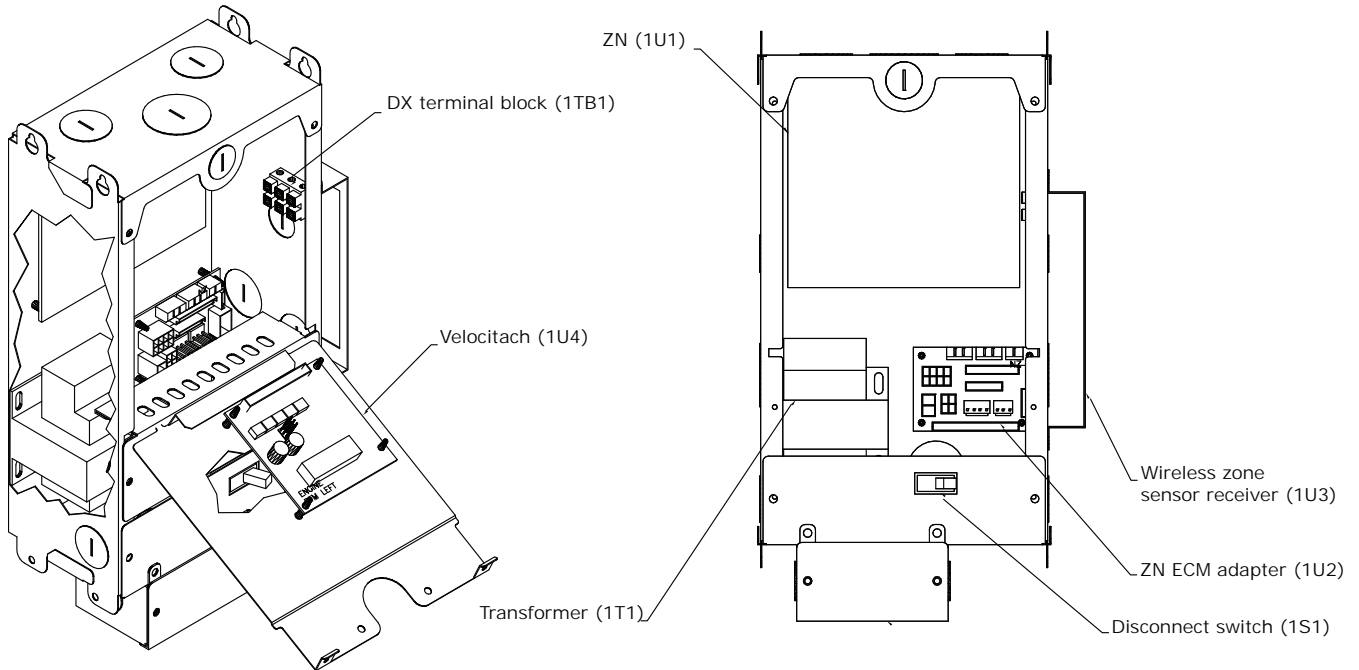
**Figure 110. BCCD unit with electric heat, condensate overflow, low-limit switch, outside air temp, and discharge air temp**



**Note:** \*Outside air sensor located in outside air ductwork. Discharge air temp sensor field installed in ductwork.

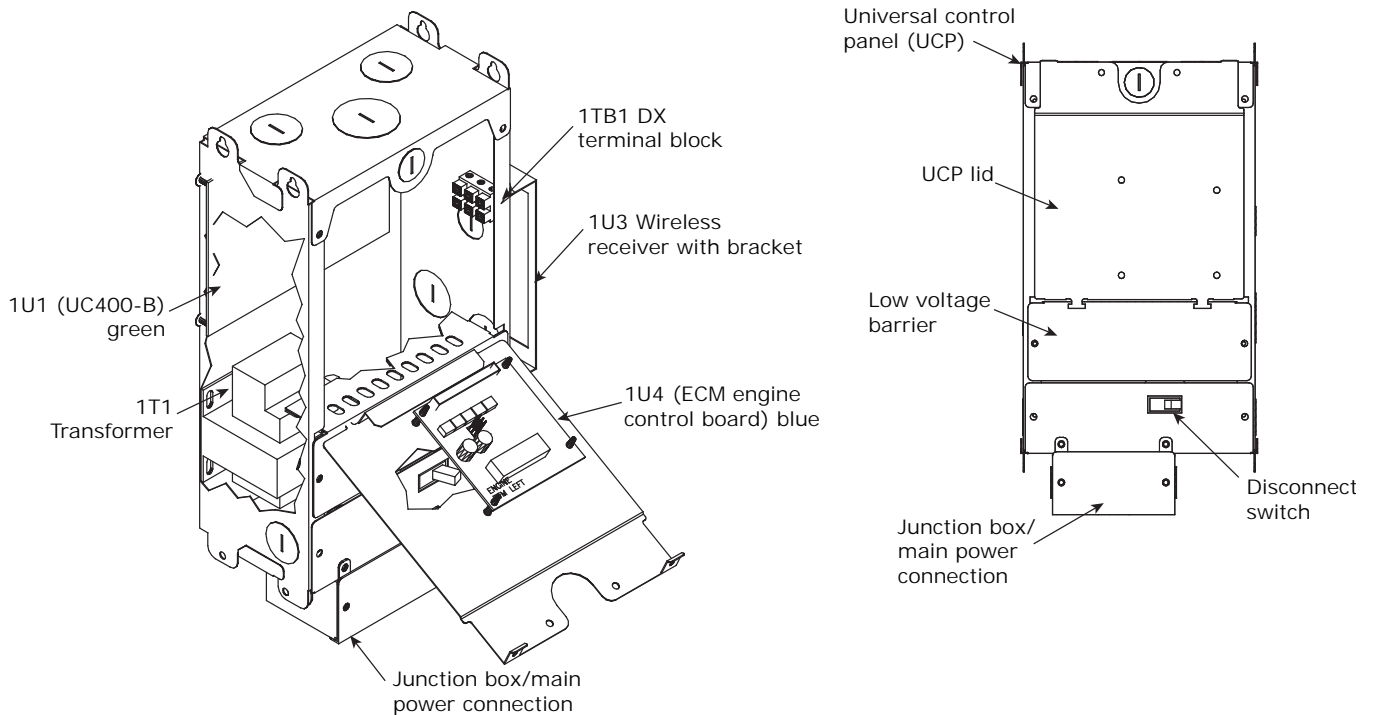
## Layout and Control Box Diagrams

**Figure 111. Control box for Tracer® ZN010/ZN510/ZN520, DX coil, wireless zone sensor**

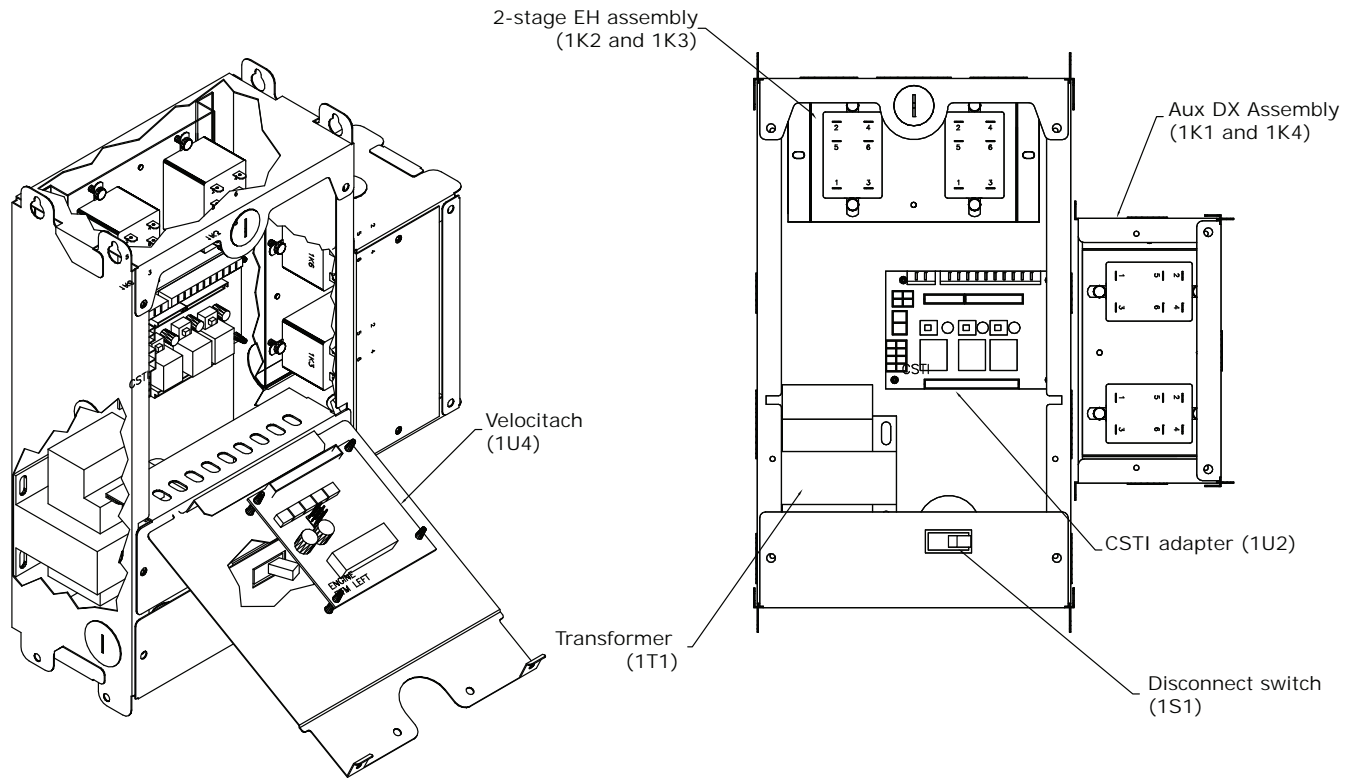


Note: Wireless zone sensor receiver can be mounted either left hand or right hand depending on unit arrangement.

**Figure 112. Control box for Tracer® UC400-B controller**

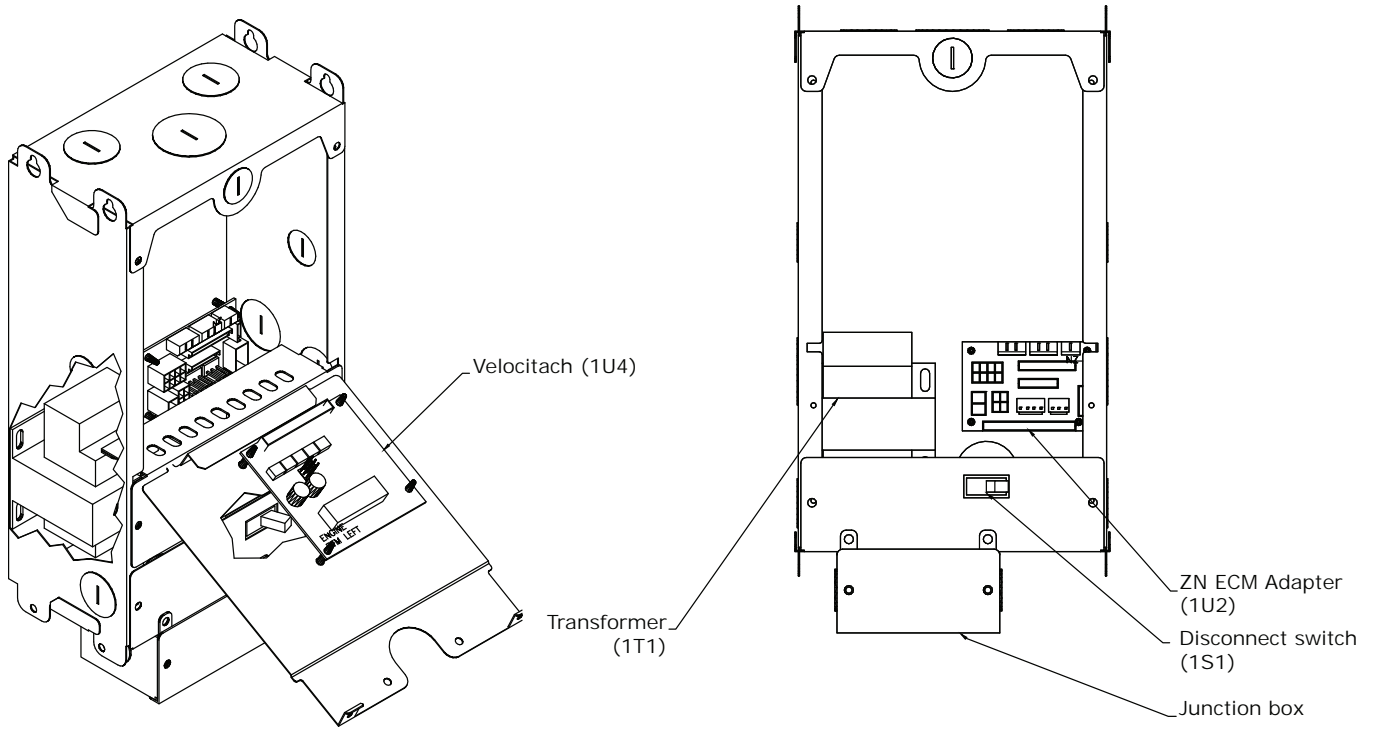


**Figure 113. Control box for CSTI with 2-stage EH and DX coil**



Note: Aux DX assembly can be mounted either left hand or right hand depending on unit arrangement.

**Figure 114. Control box for FSS**





Trane - by Trane Technologies (NYSE: TT), a global climate innovator - creates comfortable, energy efficient indoor environments for commercial and residential applications. For more information, please visit [trane.com](http://trane.com) or [tranetechnologies.com](http://tranetechnologies.com).

Trane has a policy of continuous product and product data improvement and reserves the right to change design and specifications without notice. We are committed to using environmentally conscious print practices.