



T&S BRASS AND BRONZE WORKS, INC.
 2 Saddleback Cove / P.O. Box 1088
 Travelers Rest, SC 29690

Model No.
B-0507-02

Item No.

Travelers Rest, SC: 800-476-4103 • Simi Valley, CA: 800-423-0150 • Fax: 864-834-3518 • www.tsbrass.com

This Space for Architect/Engineer Approval

Job Name _____ Date _____

Model Specified _____ Quantity _____

Customer/Wholesaler _____

Contractor _____

Architect/Engineer _____

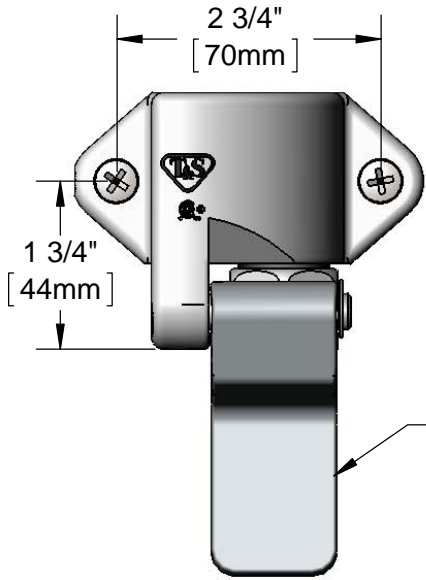

Chrome Plated brass Pedal

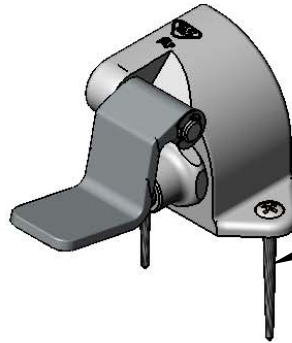

(2) Wood Mounting Screws (Included)

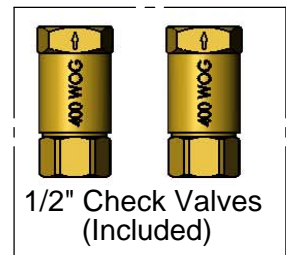
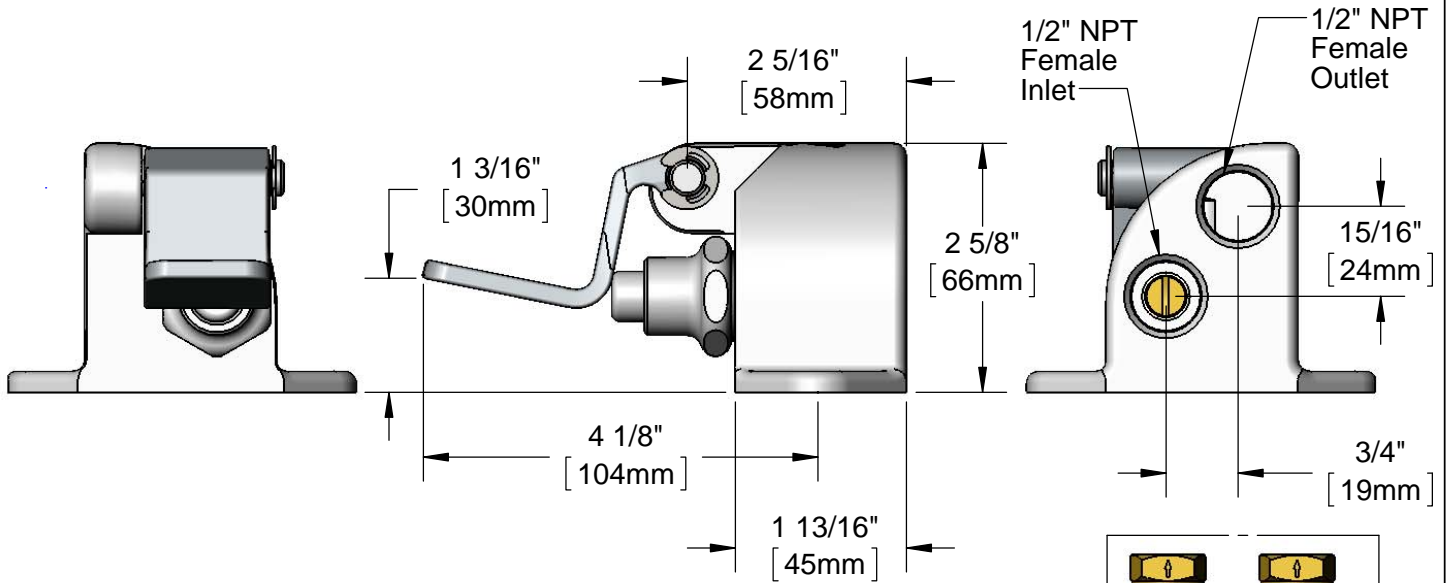

1/2" Check Valves (Included)

Product Specifications:
 Single Foot Pedal Valve w/ 1/2" NPT Female Inlet & Outlet

Product Compliance:
 ASME A112.18.1 / CSA B125.1
 NSF 61 - Section 9
 NSF 372 (Low Lead Content)



T&S BRASS AND BRONZE WORKS, INC.
 2 Saddleback Cove / P.O. Box 1088
 Travelers Rest, SC 29690

Model No.
B-0507-02

Item No.

Travelers Rest, SC: 800-476-4103 • Simi Valley, CA: 800-423-0150 • Fax: 864-834-3518 • www.tsbrass.com

ITEM NO.	SALES NO.	DESCRIPTION
1	005312-40	Pedal Valve Bonnet
2	000090-25	Foot Pedal
3	012512-45	E-clip Retaining Ring
4	003749-45	Mounting Screw
5	B-CVV1-2	1/2" Check Valve

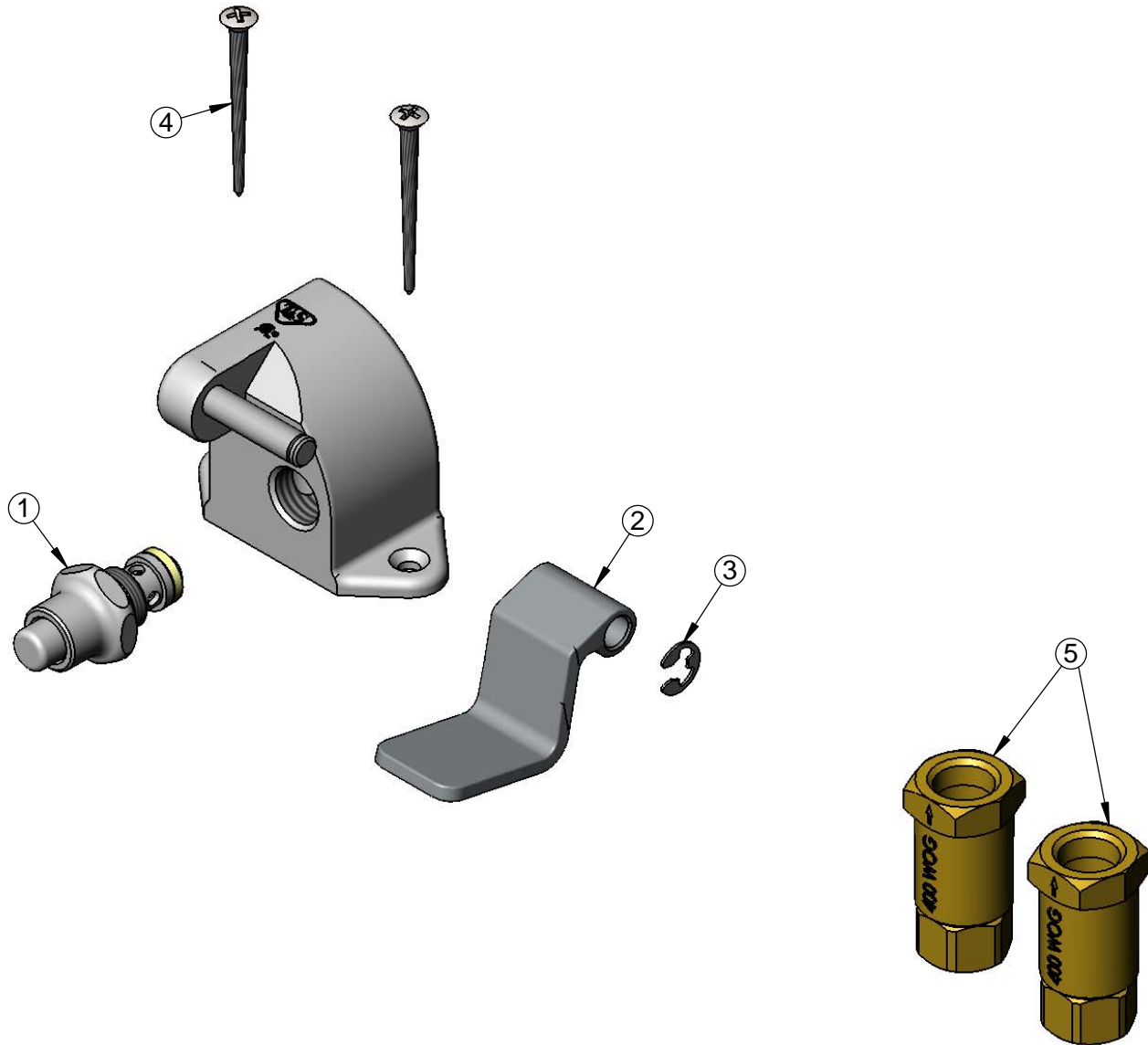

Product Specifications:
 Single Foot Pedal Valve w/ 1/2" NPT Female Inlet & Outlet

Product Compliance:
 ASME A112.18.1 / CSA B125.1
 NSF 61 - Section 9
 NSF 372 (Low Lead Content)