



**T&S BRASS AND BRONZE WORKS, INC.**  
 2 Saddleback Cove / P.O. Box 1088  
 Travelers Rest, SC 29690

Model No.  
**B-1029-UCP**

Item No.

Travelers Rest, SC: 800-476-4103 • Simi Valley, CA: 800-423-0150 • Fax: 864-834-3518 • www.tsbrass.com

This Space for Architect/Engineer Approval

Job Name \_\_\_\_\_ Date \_\_\_\_\_

Model Specified \_\_\_\_\_ Quantity \_\_\_\_\_

Customer/Wholesaler \_\_\_\_\_

Contractor \_\_\_\_\_

Architect/Engineer \_\_\_\_\_



**ADA Compliant**

1 3/16"  
 [30mm]

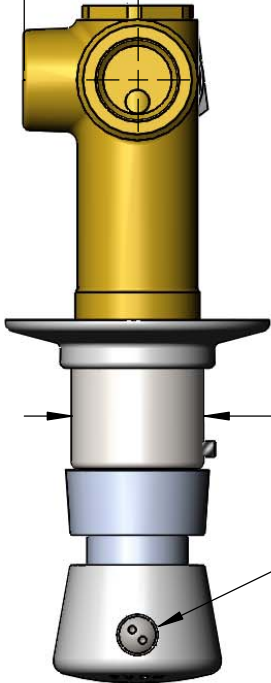

Ø 1 3/8"  
 [35mm]

Adjustable Flow, Vandal  
 Resistant Push Button  
 Metering Cartridge

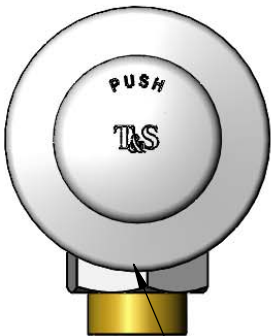
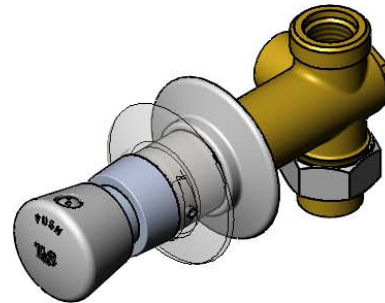

Ø 2 3/4" [70mm]  
 Adjustable Flange  
 w/ Set Screw

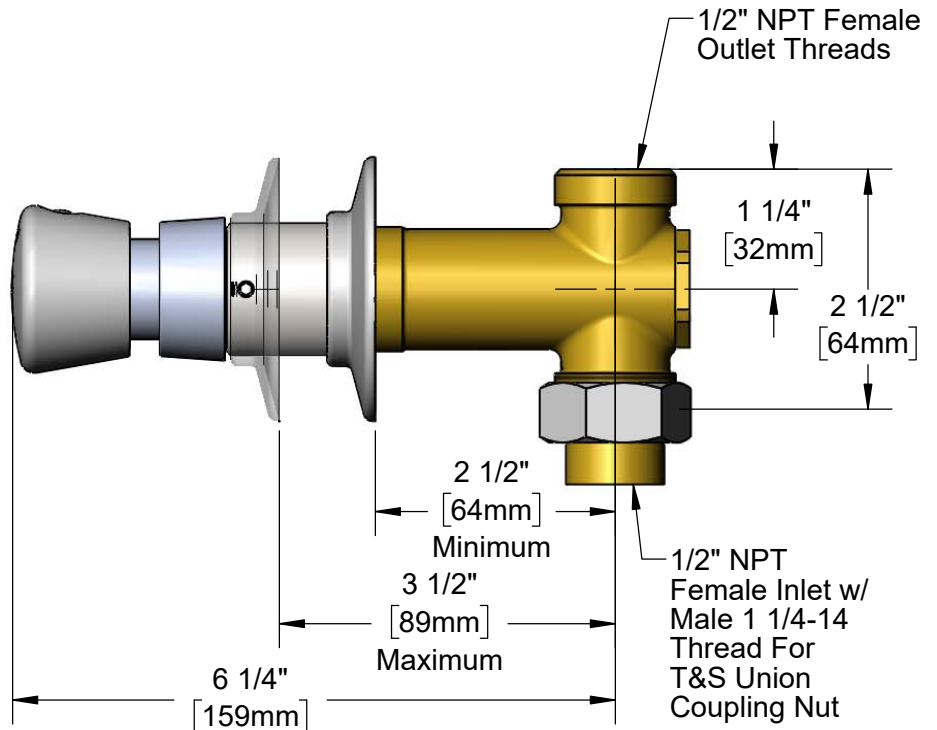

**Product Specifications:**

Concealed Straight Single Valve w/ Metering Cartridge, Vandal Resistant Design, Blank Push Button, 1/2" NPT Outlet and 1/2" NPT Female Inlet w/ Union Coupling

**Product Compliance:**

ASME A112.18.1 / CSA B125.1  
 NSF 61 - Section 9  
 NSF 372 (Low Lead Content)  
 ANSI A117.1 (ADA)



# T&S BRASS AND BRONZE WORKS, INC.

2 Saddleback Cove / P.O. Box 1088  
Travelers Rest, SC 29690

Model No.

**B-1029-UCP**

Item No.

Travelers Rest, SC: 800-476-4103 • Simi Valley, CA: 800-423-0150 • Fax: 864-834-3518 • www.tsbrass.com

ITEM NO.	SALES NO.	DESCRIPTION
1	014193-40	Blank Push Button
2	238A	Push Button Metering Cartridge
3	001501-40	Escutcheon
4	150F	8-32 UN Set Screw
5	151F	Escutcheon Tube
6	001019-45	Coupling Nut Washer
7	153F	Union Half, 1/2 NPT w/ Washer
8	000721-25	Flange Coupling Nut
9	238AB	Metering Cartridge w/ Push Button

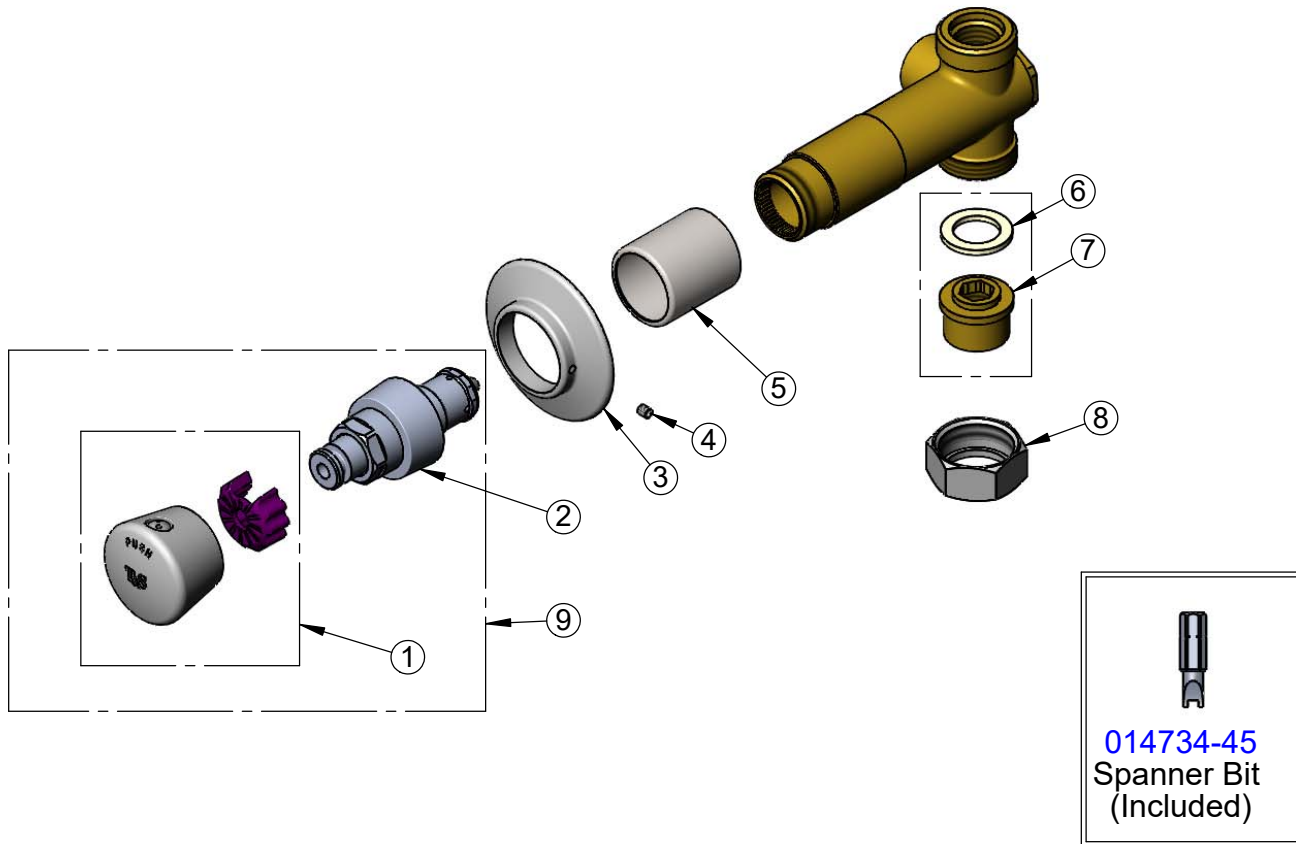

**Product Specifications:**

Concealed Straight Single Valve w/ Metering Cartridge, Vandal Resistant Design, Blank Push Button, 1/2" NPT Outlet and 1/2" NPT Female Inlet w/ Union Coupling

**Product Compliance:**

ASME A112.18.1 / CSA B125.1  
NSF 61 - Section 9  
NSF 372 (Low Lead Content)  
ANSI A117.1 (ADA)