

TOSHIBA

FILE NO. 810-200558
(MFR'S VERSION A)

SERVICE MANUAL

COLORSTREAM® HD

SRS
WOW

HDMI

DOLBY
DIGITAL

HDTV
MONITOR

DVD
VIDEO

COMPACT
disc
DIGITAL AUDIO

LC DVD™

LCD TV/DVD

20HLV85

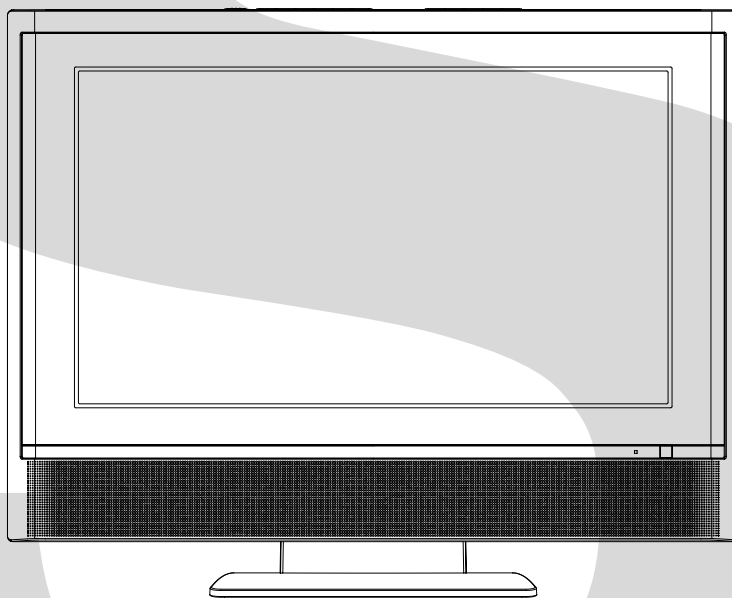

TOSHIBA AMERICA CONSUMER PRODUCTS, L.L.C.

Head Office
82 Tolowa Road, Wayne, NJ 07470
National Service Division
1420B Toshiba Drive, Lebanon, TN 37087

CableClear, ColorStream, TheaterWide and StableSound are registered trademarks of Toshiba America Consumer Products, L.L.C.
LCDVD and GameTimer are trademarks of Toshiba America Consumer Products, L.L.C.

TOSHIBA

Printed in Thailand

TOSHIBA



Introduction

Connecting your TV/DVD

Setting up your TV/DVD

Using the TV/DVD's Features

DVD Playback

Appendix

OWNER'S MANUAL

LCD TV/DVD

COLORSTREAM HD DOLBY DIGITAL SRS WOW HDMI
THEATERWIDE HD HDTV DVD GAME TIMER LCDVD

Owner's Record

The model number and serial number are on the back of your TV/DVD. Record these numbers in the spaces below. Refer to these numbers whenever you communicate with your Toshiba dealer about this TV/DVD.

Model number: _____
Serial number: _____

17HLV85

20HLV85

© 2005 TOSHIBA CORPORATION
All Rights Reserved

Introduction

Always read and understand the **PRODUCT WARNINGS** and **USER DIRECTIONS** that are contained in this manual before attempting to use your television, to help ensure its safe use. Always store this manual near your television for convenient future reference.

Dear Customer,

Thank you very much for purchasing this Toshiba television. You must carefully read and understand all of the safety instructions contained in this manual before you attempt to use this product in order to avoid potential hazards that could cause bodily injury or property damage or could damage your television.

We hope that you are completely satisfied with your Toshiba television and that it will give you long and enjoyable service. We look forward to providing you with additional Toshiba products to serve all of your entertainment needs in the future.

Safety Precautions

WARNING: TO REDUCE THE RISK OF FIRE OR ELECTRIC SHOCK, DO NOT EXPOSE THIS APPLIANCE TO RAIN OR MOISTURE.



CAUTION: TO REDUCE THE RISK OF ELECTRIC SHOCK, DO NOT REMOVE COVER (OR BACK). NO USER-SERVICEABLE PARTS INSIDE. REFER SERVICING TO QUALIFIED SERVICE PERSONNEL.

The lightning flash with arrowhead symbol, within an equilateral triangle, is intended to alert the user to the presence of uninsulated "dangerous voltage" within the product's enclosure that may be of sufficient magnitude to constitute a risk of electric shock to persons.

The exclamation point within an equilateral triangle, is intended to alert the user to the presence of important operating and maintenance (servicing) instructions in the literature accompanying the appliance.

CAUTION: To reduce the risk of electric shock, do not use the polarized plug with an extension cord, receptacle, or other outlet unless the blades can be inserted completely to prevent blade exposure.

WARNING: Handling the cord on this product or cords associated with accessories sold with this product will expose you to lead, a chemical known to the State of California to cause birth defects or other reproductive harm. **Wash hands after handling.**

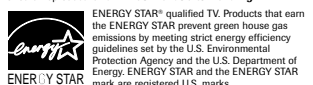

WARNING: Always use the Toshiba wall bracket specified below or another wall bracket approved by Toshiba for wall mounting this television. The use of any wall bracket other than the Toshiba wall bracket specified below or another wall bracket approved by Toshiba for wall mounting this television could result in serious bodily injury and/or property damage.

In the U.S.:
Use Toshiba wall bracket model number **FWB2027**. For more information, call TACP's Consumer Solutions Center at 1-800-631-3811 or visit TACP's website at www.tacp.toshiba.com.
In Canada:
Call TCL's Customer Service Department at 1-800-268-3404.

NOTE TO CATV INSTALLERS

This is a reminder to call the CATV system installer's attention to Article 820-40 of the NEC, which provides guidelines for proper grounding and, in particular, specifies that the cable ground shall be connected to grounding system of the building, as close to the point of cable entry as practical. For additional antenna grounding information, see item 17 on page 4.

Child Safety

It Makes A Difference Where Your TV Stands

Congratulations on your purchase!

As you enjoy your new TV, keep these safety tips in mind:

The Issue

- If you are like most consumers, you have a TV in your home. Many homes, in fact, have more than one TV.
- The home theater entertainment experience is a growing trend, and larger TVs are popular purchases; however, they are not always supported on the proper TV stands.
- Sometimes TVs are improperly secured or inappropriately situated on dressers, bookcases, shelves, desks, audio speakers, chests, or carts. As a result, TVs may fall over, causing unnecessary injury.

Toshiba Cares!

- The Consumer electronics industry is committed to making home entertainment enjoyable and safe.
- The Consumer Electronics Association formed the Home Entertainment Support Safety Committee, comprised of TV and consumer electronics furniture manufacturers, to advocate children's safety and educate consumers and their families about television safety.

Tune Into Safety

- One size does NOT fit all! Use appropriate furniture large enough to support the weight of your TV (and other electronic components).
- Use appropriate angle braces, straps, and anchors to secure your furniture to the wall (but never screw anything directly into the TV).
- Carefully read and understand the other enclosed instructions for proper use of this product.
- Do not allow children to climb on or play with furniture and TVs.
- Avoid placing any item on top of your TV (such as a VCR, remote control, or toy) that a curious child may reach for.
- Remember that children can become excited while watching a program and can potentially push or pull a TV over.
- Share our safety message about this hidden hazard of the home with your family and friends. Thank you!



2500 Wilson Blvd.
Arlington, VA 22201 U.S.A.
Tel. 703-907-7600 Fax 703-907-7600
www.CEA.org
CEA is the Sponsor, Producer and Manager of the International CES®

FCC compliance information

CAUTION: TO PREVENT ELECTRIC SHOCK DO NOT USE THIS POLARIZED PLUG WITH AN EXTENSION CORD, RECEPTACLE OR OTHER OUTLET UNLESS THE BLADES CAN BE FULLY INSERTED TO PREVENT BLADE EXPOSURE.

Federal Communications Commission (FCC):

This equipment complies with Part 15 of the FCC rules.

FCC Declaration of Conformity Compliance Statement (Part 15):

The Toshiba 17HLV85/20HLV85, LCD TV/DVD Combination complies with Part 15 of the FCC rules. Operation is subject to the following two conditions: (1) this device may not cause harmful interference, and (2) this device must accept any interference received, including interference that may cause undesired operation.

The party responsible for compliance to these rules is:

Toshiba America Consumer Products, L.L.C.
82 Tolowa Rd. Wayne, NJ 07470.
Ph: (800) 631-3811

NOTE: This equipment has been tested and found to comply with the limits for a Class B digital device, pursuant to Part 15 of the FCC rules. These limits are designed to provide reasonable protection against harmful interference in a residential installation. This equipment generates, uses, and can radiate radio frequency energy and, if not installed and used in accordance with the instructions, may cause harmful interference to radio communications. However, there is no guarantee that interference will not occur in a particular installation. If this equipment does cause harmful interference to radio or television reception, which can be determined by removing and applying power to the equipment, the user is encouraged to try to correct the interference by one or more of the following measures:

- Reorient or relocate the receiving antenna.
- Increase the separation between the equipment and the receiver.
- Connect the equipment into an outlet on a circuit different from that to which the receiver is connected.
- Consult the dealer or an experienced radio/TV technician for help.

CAUTION: Changes or modifications to this equipment not expressly approved by Toshiba could void the user's authority to operate this equipment.

CAUTION: THIS DIGITAL VIDEO PLAYER EMPLOYS A LASER SYSTEM. TO ENSURE PROPER USE OF THIS PRODUCT, PLEASE READ THIS OWNER'S MANUAL CAREFULLY AND RETAIN FOR FUTURE REFERENCE. SHOULD THE UNIT REQUIRE MAINTENANCE, CONTACT AN AUTHORIZED SERVICE LOCATION. USE OF CONTROLS, ADJUSTMENTS OR THE PERFORMANCE OF PROCEDURES OTHER THAN THOSE SPECIFIED HEREIN MAY RESULT IN HAZARDOUS RADIATION EXPOSURE. TO PREVENT DIRECT EXPOSURE TO LASER BEAM, DO NOT TRY TO OPEN THE ENCLOSURE. VISIBLE LASER RADIATION MAY BE PRESENT WHEN THE ENCLOSURE IS OPENED. DO NOT STARE INTO BEAM.

Location of the required Marking

The rating sheet and the safety caution are the rear of the unit.

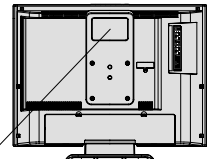

CERTIFICATION: COMPLIES WITH FDA RADIATION PERFORMANCE STANDARDS, 21 CFR SUBCHAPTER J.

IMPORTANT SAFEGUARDS

- 1. READ INSTRUCTIONS**
All the safety and operating instructions should be read before the unit is operated.
- 2. RETAIN INSTRUCTIONS**
The safety and operating instructions should be retained for future reference.
- 3. HEED WARNINGS**
All warnings on the unit and in the operating instructions should be adhered to.
- 4. FOLLOW INSTRUCTIONS**
All operating and use instructions should be followed.
- 5. CLEANING**
Unplug this unit from the wall outlet before cleaning. Do not use liquid cleaners or aerosol cleaners. Clean only with a dry cloth.
- 6. ATTACHMENTS**
Do not use attachments not recommended by the product manufacturer as they may cause hazards.
- 7. WATER AND MOISTURE**
Do not use this unit near water. For example, near a bathtub, washbowl, kitchen sink, laundry tub, in a wet basement, or near a swimming pool.



Introduction

Introduction

Connecting your TV/DVD

Setting up your TV/DVD

Using the TV/DVD's Features

DVD Playback

Appendix

2

3

8. ACCESSORIES

Do not place this product on an unstable cart, stand, tripod, bracket, or table. The product may fall, causing serious injury to a child or adult, and serious damage to the product. Use only with a cart, stand, tripod, bracket, or table recommended by the manufacturer, or sold with the product. Any mounting of the product should follow the manufacturer's instructions, and should use a mounting accessory recommended by the manufacturer.

8A. An appliance and cart combination should be moved with care. Quick stops, excessive force, and uneven surfaces may cause the appliance and cart combination to overturn.

9. VENTILATION

Slots and openings in the cabinet back or bottom are provided for ventilation, and to ensure reliable operation of the unit, and to protect it from overheating. These openings must not be blocked or covered. The openings should never be blocked by placing the unit on a bed, sofa, rug, or other similar surface. This unit should never be placed near or over a radiator or heat source. This unit should not be placed in a built-in installation such as a bookcase or rack unless proper ventilation is provided or the manufacturer's instructions have been adhered to.

10. POWER SOURCE

This unit should be operated only from the type of power source indicated on the rating plate. If you are not sure of the type of power supply to your home, consult your appliance dealer or local power company.

11. GROUNDING OR POLARIZATION

This unit is equipped with a polarized alternating-current line plug (a plug having one blade wider than the other). This plug will fit into the power outlet only one way. This is a safety feature. If you are unable to insert the plug fully into the outlet, try reversing the plug. If the plug should still fail to fit, contact your electrician to replace your obsolete outlet.

12. POWER-CORD PROTECTION

Power-supply cords should be routed so that they are not likely to be walked on or pinched by items placed upon or against them, paying particular attention to cords at plugs, convenience receptacles, and the point where they exit from the appliance.

13. LIGHTNING

To protect your unit from lightning storm, or when it is left unattended and unused for long periods of time, unplug it from the wall outlet and disconnect the antenna or cable system. This will prevent damage to the unit due to lightning and power line surges.

14. POWER LINES

An outside antenna system should not be located in the vicinity of overhead power lines or other electric light or power circuits, or where it can fall onto or against such power lines or circuits. When installing an outside antenna system, extreme care should be taken to keep from touching such power lines or circuits, as contact with them might be fatal.

15. OVERLOADING

Do not overload wall outlets and extension cords, as this can result in a risk of fire or electric shock.

16. OBJECT AND LIQUID ENTRY

Do not push objects through any openings in this unit, as they may touch dangerous voltage points or short out parts that could result in fire or electric shock. Never spill or spray any type of liquid into the unit.

17. OUTDOOR ANTENNA GROUNDING

If an outside antenna or cable system is connected to the unit, be sure the antenna or cable system is grounded to provide some protection against voltage surges and built-up static charges. Section 810 of the National Electrical Code (NEC), ANSI/NFPA 70, provides information with respect to proper grounding of the mast and supporting structure, grounding of the lead-in wire to an antenna discharge unit, size of grounding conductors, location of antenna discharge unit, connection to grounding electrodes, and requirements for the grounding electrode.

EXAMPLE OF ANTENNA GROUNDING AS PER THE NATIONAL ELECTRICAL CODE

NEC-NATIONAL ELECTRICAL CODE S2898A

POWER SERVICE GROUNDING ELECTRODE SYSTEM (NEC ART 250, PART H)

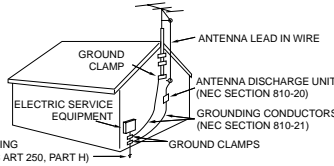

4

PORTABLE CART WARNING (symbol provided by RETAC)

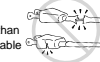

18. SERVICING

Do not attempt to service this unit yourself, as opening or removing covers may expose you to dangerous voltage or other hazards. Refer all servicing to qualified service personnel.

For example:

- When the power-supply cord or plug is damaged.
- If liquid has been spilled, or objects have fallen into the unit.
- If the unit has been exposed to rain or water.
- If the unit does not operate normally by following the operating instructions. Adjust only those controls that are covered by the operating instructions, as an improper adjustment of other controls may result in damage and will often require extensive work by a qualified technician to restore the unit to its normal operation.
- If the unit has been dropped or the cabinet has been damaged.
- When the unit exhibits a distinct change in performance, this indicates a need for service.

19. REPLACEMENT PARTS

When replacement parts are required, be sure the service technician uses replacement parts specified by the manufacturer or those that have the same characteristics as the original part. Unauthorized substitutions may result in fire, electric shock or other hazards.

20. SAFETY CHECK

Upon completion of any service or repairs to this unit, ask the service technician to perform safety checks to determine that the unit is in proper operating condition.

21. HEAT

The product should be situated away from heat sources such as radiators, heat registers, stoves, or other products (including amplifiers) that produce heat.

22. DISC SLOT

Keep your fingers well clear of the disc slot as it is closing. Failure to do so may cause serious personal injury.

23. CONNECTING

When you connect the product to other equipment, turn off the power and unplug all of the equipment from the wall outlet. Failure to do so may cause a product damage. Read the owner's manual of the other equipment carefully and follow the instructions when making any connections.

24. HEADPHONES

When you use headphones, keep the volume at a moderate level. Using headphones continuously at a high volume may cause hearing damage.

25. LASER BEAM

Do not look into the opening of the disc slot or ventilation opening of the product to see the source of the laser beam. Doing so may cause sight damage.

26. DISC

Do not use a cracked, deformed, or repaired disc. These discs are easily broken and may cause serious personal injury and product malfunction.

27. LCD

Do not press on or jolt the LCD panel. Doing so may cause the LCD panel glass to break and injury may occur. Should the LCD panel be broken and liquid leaks out, do not inhale or swallow it. Doing so may cause poisoning. If you have got it into your mouth, wash it out and consult your doctor. If your hands or clothes have touched it, wipe them with alcohol and a cleaning cloth and then wash them.

28. NOTE TO CABLE TV SYSTEM INSTALLER

This reminder is provided to call the Cable TV system installer's attention to Article 820-40 of the NEC that provides guidelines for proper grounding and, in particular, specifies that the cable ground shall be connected to the grounding system of the building, as close to the point of cable entry as practical.

ON DISPOSAL

This product contains mercury. Disposal of mercury may be regulated due to environmental considerations. For disposal or recycling information, please contact your local authorities or the Electronic Industrial Alliance: www.eiae.org.

5

Precautions

Important notes about your LCD TV

The following symptoms are technical limitations of LCD Display technology and are not an indication of malfunction. Therefore, Toshiba is not responsible for perceived defects resulting from these symptoms.

- An afterimage (ghost) may appear on the screen if a fixed, nonmoving image is displayed for a long period of time. The afterimage is not permanent and will disappear in a short period of time.
- The LCD panel contained in this TV is manufactured using an extremely high level of precision technology; however, there may be an occasional pixel (dot of light) that does not operate properly (does not light, remains constantly lit, etc.). This is a structural property of LCD technology, is not a sign of malfunction, and is not covered under your warranty. Such pixels are not visible when the picture is viewed from a normal viewing distance.
Note: Interactive video games that involve shooting a "gun" type of joystick at an on-screen target may not work on this TV.

Notes on handling

- Do not subject the LCD panel to physical shock, such as dropping it. It may cause unit damage and malfunction.
- Retain the original shipping carton and packing materials. For maximum protection when shipping, repack the unit as it was originally packed at the factory.
- Do not use volatile liquids, such as insecticide, near the unit. Do not leave rubber or plastic products in contact with the unit for prolonged periods of time. Doing so will leave marks on the finish.
- The top and rear panels of the unit may become warm after a long period of use. This is not a malfunction.
- When the unit is not in use, always remove the disc and turn off the power.
- If you do not use the unit for a long period, the unit may not function properly in the future. Turn on and use the unit occasionally.

Notes on locating the unit

- When you place this unit near a TV, radio, or VCR, the playback picture may become poor and the sound may be distorted. In this case, place the unit away from the TV, radio, or VCR.
- To avoid damage to this product, never place or store the TV/DVD in direct sunlight; hot, humid areas; or areas subject to excessive dust or vibration.
- Always place the TV/DVD on the floor or a sturdy, level stable surface that can support the weight of the unit. Use a sturdy tie between the TV/DVD's rear hooks and the rear wall, pillar, etc., or screw the TV to the stand using the TV's rear screw hole or a safety band (see illustration).

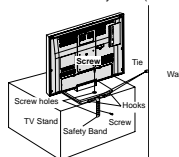

Note on cleaning

Clean only with a soft, dry, lint-free cloth.

6

Notes on moisture condensation

Moisture condensation damages the unit. Please read the following carefully.

Moisture condensation occurs, for example, when you pour a cold drink into a glass on a warm day and drops of water form on the outside of the glass. In the same way, moisture may condense on this unit's internal optical pickup lens, one of the most crucial internal parts of the unit.

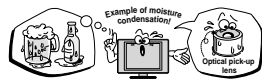

Moisture condensation may occur in the following situations:

- When you move the unit from a cold area to a warm area.
- When you use the unit in a room in which the heat was just turned on.
- When you use the unit in an area where cold air from an air conditioner directly hits the unit.
- When you use the unit in a humid area.



Never use the unit when moisture condensation may occur.

Using the unit when moisture condensation exists may damage discs and internal parts. Remove the disc, connect the power cord of the unit to the wall outlet, turn on the unit, and leave it for two or three hours. After two or three hours, the unit will have warmed up and evaporated any moisture. Keep the unit connected to the wall outlet and moisture condensation will seldom occur.



Notes on discs

On handling discs

- Do not touch the playback side of the disc.

DO

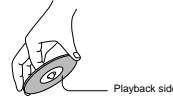

- Do not attach paper or tape to discs.

DO NOT



On cleaning discs

- Fingerprints and dust on the disc cause picture and sound deterioration. Wipe the disc from the center outward with a soft, lint-free cloth. Always keep the disc clean.

DO



DO NOT



- Never use any type of solvent such as thinner, benzene, commercially available cleaners, or antistatic spray made for use on vinyl LPs. Use of such liquids may damage the disc.

On storing discs

- Never store discs in a place subject to direct sunlight or near heat sources.
- Never store discs in places subject to moisture and dust such as a bathroom or near a humidifier.
- Always store discs vertically in a case. Stacking or placing objects on discs outside of their case may cause warping.

Structure of disc contents

Normally, DVD video discs are divided into titles, and the titles are sub-divided into chapters. Video CDs and Audio CDs are divided into tracks.

DVD video disc

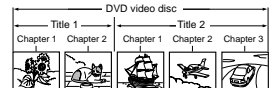

Video CD/Audio CD



Each title, chapter or track is assigned a number, which is called "title number", "chapter number" or "track number" respectively. Some discs may not have these numbers.

Notes on copyright

The unauthorized recording, use, distribution, or revision of television programs, video tapes, DVDs, and other materials is prohibited under the Copyright Laws of the United States and other countries, and may subject you to civil and criminal liability.

This product incorporates copyright protection technology that is protected by method claims of certain U.S. patents and other intellectual property rights owned by Macrovision Corporation and other rights owners. Use of this copyright protection technology must be authorized by Macrovision Corporation and is intended for home and other limited viewing uses only unless otherwise authorized by Macrovision Corporation. Reverse engineering or disassembly is prohibited.

7

About this owner's manual

This owner's manual explains the basic instructions of this unit. Some DVD video discs are produced in a manner that allows specific or limited operation during playback. As such, the unit may not respond to all operating commands. This is not a defect in the unit. Refer to instruction notes of discs.

A may appear on the TV screen during operation. A means that the operation is not permitted by the unit or the disc. For example, sometimes it is unable to stop the playback of copyright message of the disc when the STOP (■) button is pressed. Alternatively, the may also indicate that the feature is not available for the disc.

Notes on region numbers

The region number of this unit is 1. If region numbers, which stand for their playable area, are printed on your DVD video disc and you do not find or , disc playback will not be allowed by the player. (In this case, the unit will display a message on-screen.) Some DVDs that have no region code label may still be subject to area restrictions and therefore are not playable.

On Video CDs

The DVD player contained in this LCD TV supports Video CDs equipped with the PBC (Version 2.0) function. (PBC is the abbreviation of Playback Control.) You can enjoy two playback variations depending on types of discs.

- **Video CD not equipped with PBC function (Version 1.1)**
Sound and movie can be played on this DVD in the same way as an audio CD.
- **Video CD equipped with PBC function (Version 2.0)**

In addition to operation of a Video CD not equipped with the PBC function, you can enjoy playback of interactive software with search function by using the menu displayed on the TV screen (Menu Playback). Some of the functions described in this owner's manual may not work with some discs.

Playable discs

This unit can play the following discs.

Disc Mark	Contents	Disc Size	Maximum playback time
	Audio + Video (moving pictures)	12 cm	Approx. 4 hours (single sided disc)
		8 cm (with Disc adapter)	Approx. 80 minutes (single sided disc)
	Audio + Video (moving pictures)	12 cm	Approx. 74 minutes
		8 cm (with Disc adapter)	Approx. 20 minutes
	Audio	12 cm	Approx. 74 minutes
		8 cm (CD single) (with Disc adapter)	Approx. 20 minutes

The following discs are also available.

- DVD-R/RW discs of DVD video format
- CD-R/CD-RW discs of CD-DA, Video CD, MP3, WMA or JPEG format
- Kodak Picture CD and FUJICOLOR CD format

Some of these discs may be incompatible.

- You cannot play discs other than those listed above.
- You cannot play discs of DVD-RAM, DVD-ROM, Photo CD, etc., or non standardized discs even if they may be labeled as above.
- Some CD-R/RW's cannot be played back depending on the recording conditions.
- This unit uses the NTSC color system, and cannot play DVD video discs recorded in any other color system (PAL, SECAM, etc.).
- When you playback the 8 cm disc, you need an adapter (not supplied).

Because of problems and errors that can occur during the creation of DVD and CD software and/or the manufacture of DVD and CD discs, Toshiba cannot guarantee that the DVD player contained in this LCD TV will play every feature of every DVD bearing the DVD logo and/or every CD bearing the CD logo. As one of the creators of DVD technology, Toshiba DVD players are manufactured using the highest standards of quality, and as a result, such incompatibilities are rare. If you happen to experience any difficulty playing a DVD or a CD on the DVD player contained in this LCD TV, please feel free to contact us via the methods listed in the "How to Obtain Warranty Services" sections on pages 63 and 64 (as applicable).

8

Introduction	2
FCC compliance information	3
IMPORTANT SAFEGUARDS	3
Precautions	6
Notes on discs	7
Notes on your new TV/DVD	10
Selecting a location for the TV/DVD	11
Connecting your TV/DVD	11
Connecting a VCR	11
Connecting a cable converter box or Antenna	12
Connecting a satellite receiver and a VCR	13
Connecting a DVD player with ColorStream® (component video) and a VCR	14
Connecting a DTV receiver/set-top box with ColorStream® (component video) and a VCR	15
Connecting a camcorder	16
Connecting an HDMI™ or a DVI device to the HDMI input	17
Connecting an amplifier equipped with a Dolby® Digital decoder	18
Connecting an amplifier equipped with a DTS® decoder	18
Connecting an amplifier equipped with an MPEG audio decoder	19
Connecting an amplifier equipped with a digital audio input	19
Connecting a PC (Personal Computer)	20
Power source	20
Setting up your TV/DVD	21
Using the remote control	21
Installing the remote control batteries	21
Learning about the remote control	22
Starting setup	23
Changing the on-screen display language	23
Adding channels to the TV/DVD's memory	24
Programming channels automatically	24
Adding and erasing channels manually	24
Changing channels	24
Game mode	24
Using the TV/DVD's features	25
Adjusting the channel settings	25
Switching between two channels	25
Programming your favorite channels	25
Using the LOCKS menu	26
Selecting a password	26
Using the V-Chip (parental control) feature	27
Locking channels	28
Locking the video inputs	28
Setting the GameTimer™	29
Using the panel lock feature	29
Labeling channels	30
Selecting the video input source	31
Labeling the video input sources	31
Setting the clock	31
Setting the ON timer	32
Viewing the wide-screen picture formats (480i and 480p signals only)	33
Selecting the cinema mode	34
Using the ASPECT feature	34
Setting the sleep timer	35
Using the closed caption feature	35
Adjusting the picture	36
Selecting the picture mode	36
Adjusting the picture quality	36
Using the CableClear® feature	37
Selecting the color temperature	37
Resetting your picture adjustments	37
Adjusting the sound	38
Muting the sound	38
Selecting stereo/SAP broadcasts	38
Adjusting the sound quality	39
Resetting your audio adjustments	39
Using the StableSound® feature	39
Using the WOW™ surround sound feature	39
Selecting the HDMI audio input source	40
Adjusting the back lighting feature	40
Displaying on-screen information	40
Auto power off	40
Understanding the Power Return feature	40
Picture/Audio adjustments in the PC mode	41
Resetting your picture/audio adjustments in the PC mode	41
DVD Playback	42
Playing a disc	42
Playing in fast reverse or fast forward directions	44
Playing frame by frame	44
Playing in slow-motion	44
Locating a chapter or track	44
Zooming	45
Locating desired scene	45
Marking desired scenes	46
Marking the scenes	46
Returning to the scenes	46
Repeat playback	47
A-B Repeat playback	47
Program playback	48
Random playback	48
Changing angles	49
Title selection	49
DVD menu	49
Changing soundtrack language	50
Subtitles	50
Karaoke playback	51
Disc status	51
To turn off the PBC	51
MP3/WMA/JPEG CD operation	52
MP3/WMA CD playback	53
JPEG CD playback	54
DVD function setup	55
Customizing the function settings	55
Temporary disabling of parental level by DVD disc	58
Appendix	59
Language code list	59
Troubleshooting	60
Specifications	62
Limited United States Warranty	63
Limited Canada Warranty	64

9

Exploring your new TV/DVD

You can operate your TV/DVD by using the buttons on the top panel or the remote control. The side and back panels provide the inputs to connect other equipment to your TV/DVD.

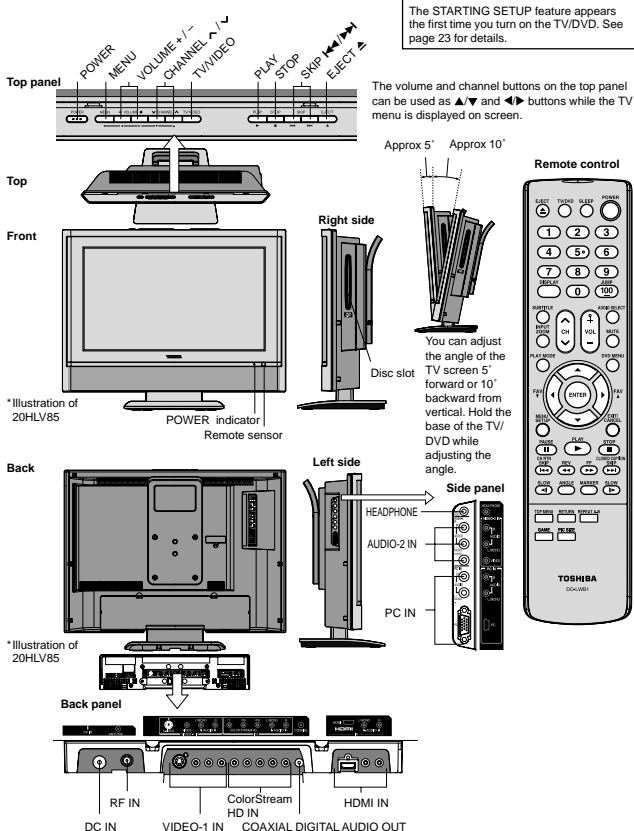

10

Selecting a location for the TV/DVD

- Place the TV/DVD on the floor or on a sturdy platform in a location where light does not directly hit the screen.
- Place the TV/DVD far enough from the walls to allow proper ventilation. Inadequate ventilation may cause overheating, which may damage the TV/DVD.

Connecting your TV/DVD

- A coaxial cable is the standard cable that comes in from your antenna or cable converter box. Coaxial cables use "F" connectors.
- Standard A/V (audio/video) cables are usually color coded according to use: yellow for video and red and white for audio. The red audio cable is for the stereo right channel, and the white audio cable is for the stereo left (or mono) channel. If you look at the rear panel of the TV/DVD, you will see that the terminals are color coded in the same manner as the cables.
- S-video cables provide better picture performance than standard video cables. S-video cables can only be used with S-video compatible components.
- Component video cables provide better picture performance than S-video cables. Component video cables can only be used with component video compatible components.
- HDMI (High Definition Multimedia Interface) cable is for use with video equipment that has HDMI output (see page 17).

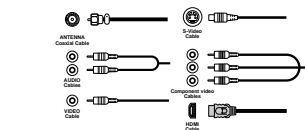

Connecting a VCR

This connection allows you to watch local channels and video programs, play or record on the VCR while watching TV, and record from one channel while watching another channel.

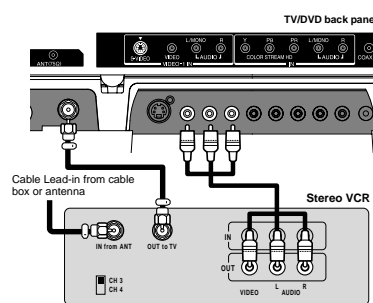

11

Connecting a cable converter box or Antenna

This television has an extended tuning range and can tune most cable channels without using a cable company supplied converter box. Some cable companies offer "premium pay channels" in which the signal is scrambled. Descrambling these signals for normal viewing requires the use of a descrambler device, which is generally provided by the cable company.

Option 1: For Subscribers to Basic Cable TV Service

For basic cable service not requiring a Converter/Descrambler box, connect the incoming 75 ohm Coaxial Cable directly to the Antenna Jack on the back of the television.

Option 2: For Subscribers to Scrambled Cable TV Service

If you subscribe to a cable service that requires the use of a Converter/Descrambler box, connect the incoming cable to the Converter/Descrambler box and connect the output of the box to the Antenna Jack on the back of the television. Follow the connections shown below. Set the television to the output of the Converter/Descrambler box (usually channel 3 or 4) and use the Converter/Descrambler box to select channels.

Option 3: For Subscribers to Unscrambled Basic Cable with Scrambled Premium Channels

If you subscribe to a cable service in which basic cable channels are unscrambled and premium channels require the use of a Converter/Descrambler box, you may wish to use a two-set signal splitter (sometimes called a "two-set coupler") and an A/B Switch box from the cable installer or an electronics supply store. Follow the connections shown below. With the switch in the "B" position, you can directly tune any non-scrambled channels on your TV/DVD. With the switch in the "A" position, tune your TV/DVD to the output of the Converter/Descrambler box (usually channel 3 or 4) and use the box to tune scrambled channels.

Note:

When you use a converter box with your TV/DVD, there may be features that you cannot program using the remote control, such as labeling channels, blocking channels, and programming your favorite channels.

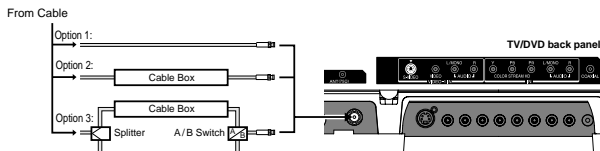

Connecting a DVD player with ColorStream® (component video) and a VCR

This connection allows you to watch DVD, VCR, or TV programs and record TV programs. You can record from one source while watching a program from another source. Your TV/DVD is capable of using ColorStream (component video). Connecting your TV/DVD to a component video compatible DVD player, such as a Toshiba DVD player with ColorStream®, can greatly enhance picture quality and performance.

You will need:

- two coaxial cables
- one set of standard A/V cables
- one set of component video cables
- one pair of standard audio cables

Note:

The ColorStream HD jacks can be used with Progressive (480p, 720p) and Interlaced (480i, 1080i) scan systems. A 1080i signal will provide the best picture performance.

The unauthorized recording, use, distribution or revision of television programs, videotapes, DVDs, and other materials is prohibited under the Copyright Laws of the United States and other countries, and may subject you to civil and criminal liability.

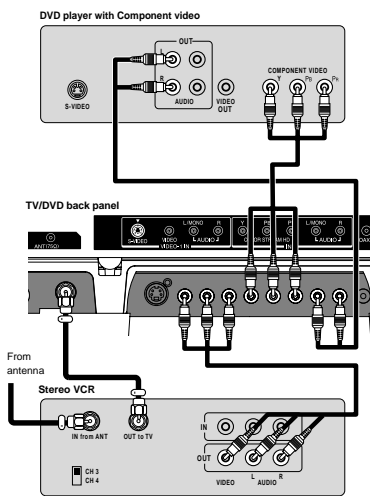

Connecting a satellite receiver and a VCR

This connection allows you to watch satellite, VCR, or TV programs. You can record from the satellite receiver and TV, as well as record one TV channel while watching another channel.

You will need:

- three coaxial cables
- two sets of standard A/V cables
- one S-video cable

Note:

You can use a standard video cable instead of the S-video cable, but the picture quality will decrease. If you use an S-video cable between the TV/DVD and DVD player/satellite receiver, make the audio connections but remove the standard video cable. Do not connect both an S-video and a standard video cable to VIDEO1 at the same time or the picture performance will be unacceptable.

The unauthorized recording, use, distribution or revision of television programs, videotapes, DVDs, and other materials is prohibited under the Copyright Laws of the United States and other countries, and may subject you to civil and criminal liability.

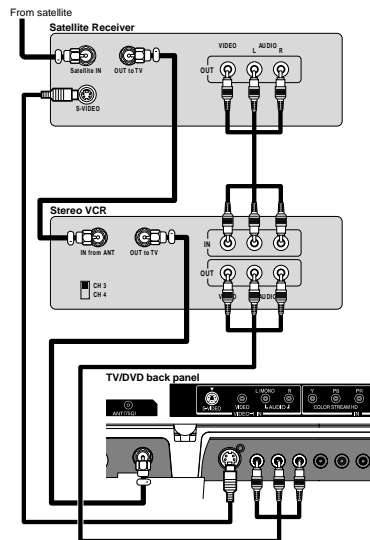

Connecting a DTV receiver/set-top box with ColorStream® (component video) and a VCR

This connection allows you to watch DTV (digital TV), VCR, and TV programs, and record DTV and TV programs. Your TV/DVD has ColorStream® (component video) inputs. Connecting your TV/DVD to a DTV receiver with component video can greatly enhance picture quality and realism.

You will need:

- three coaxial cables
- two sets of standard A/V cables
- one set of standard audio cables
- one set of component video cables

Note:

For HDMI connection, see page 17. The ColorStream HD jacks and HDMI jacks can be used with Progressive (480p, 720p) and Interlaced (480i, 1080i) scan systems. If your DTV receiver does not have component video, use the S-video and standard audio connections instead. Do not connect both an S-video and a standard video cable to VIDEO1 at the same time or the picture performance will be unacceptable.

The unauthorized recording, use, distribution, or revision of television programs, videotapes, DVDs, and other materials is prohibited under the Copyright Laws of the United States and other countries, and may subject you to civil and criminal liability.

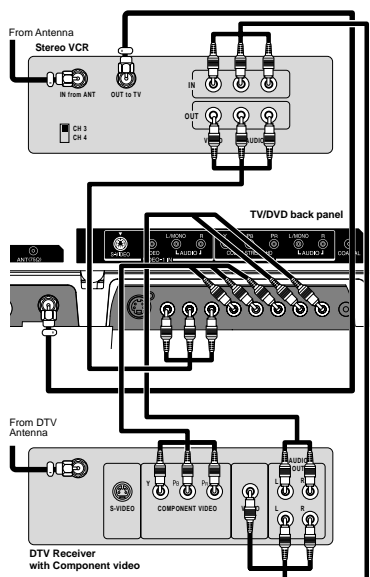

Connecting a camcorder

This connection allows you to watch videos recorded on a camcorder.

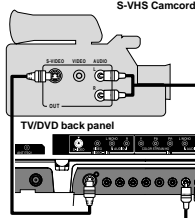
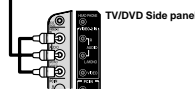
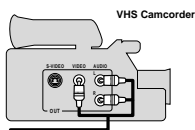

- You will need:
- one set of standard AV cables

- You will need:
- one S-video cable
 - one pair of standard audio cables

Note:
For better picture quality, if your camcorder has S-video, you can use an S-video cable (plus the standard audio cables) instead of a standard video cable.
Do not connect both a standard video cable and an S-video cable at the same time, or the picture performance will be unacceptable.

Connecting an amplifier equipped with a Dolby® Digital decoder

Dolby Digital
Dolby Digital is the surround sound technology used in theaters showing the latest movies, and is now available to reproduce this realistic effect in the home. You can enjoy motion picture and live concert DVD video discs encoded via the Dolby Digital recording system with this dynamic realistic sound by connecting the TV/DVD to a 6 channel amplifier equipped with a Dolby Digital decoder or Dolby Digital processor. If you have a Dolby Surround Pro Logic decoder, you will obtain the full benefit of Pro Logic from the same DVD movies that provide full 5.1-channel Dolby Digital soundtracks, as well as from titles with the Dolby Surround mark.

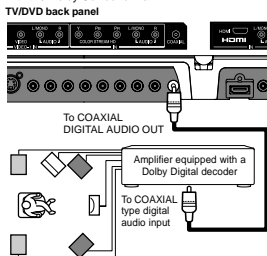

- You will need:
- one coaxial cables

- Notes:**
- DO NOT connect the COAXIAL DIGITAL AUDIO OUT jack of the TV/DVD to the AC-3 RF input of a Dolby Receiver. This input on your A/V Receiver is reserved for Laserdisc use only and is incompatible with the COAXIAL DIGITAL AUDIO OUT jack of the TV/DVD.
 - Connect the COAXIAL DIGITAL AUDIO OUT jack of the TV/DVD to the "COAXIAL" input of a Receiver or Processor.
 - Refer to the owner's manual of the connected equipment as well.
 - The output sound of the TV/DVD has a wide dynamic range. Be sure to adjust the receiver's volume to a moderate listening level. Otherwise, the speakers may be damaged by a sudden high volume sound.
 - Turn off the amplifier before you connect or disconnect the TV/DVD's power cord. If you leave the amplifier power on, the speakers may be damaged.

Manufactured under license from Dolby Laboratories. Dolby, Pro Logic, and the double-D symbol are trademarks of Dolby Laboratories.

- You will need:
- one coaxial cable

- Notes:**
- Connect the COAXIAL DIGITAL AUDIO OUT jack of the TV/DVD to the "COAXIAL" input of a Receiver or Processor.
 - Refer to the owner's manual of the connected equipment as well.
 - The output sound of the TV/DVD has a wide dynamic range. Be sure to adjust the receiver's volume to a moderate listening level. Otherwise, the speakers may be damaged by a sudden high volume sound.
 - Turn off the amplifier before you connect or disconnect the TV/DVD's power cord. If you leave the amplifier power on, the speakers may be damaged.

DTS and DTS Digital Out are trademarks of Digital Theater Systems, Inc.

Connecting an amplifier equipped with a DTS® decoder

Digital Theater Systems (DTS)
DTS is a high quality surround technology used in theaters and now available for home use, on DVD video discs or audio CDs. If you have a DTS decoder or processor, you can obtain the full benefit of 5.1 channel DTS encoded sound tracks on DVD video discs or audio CDs.

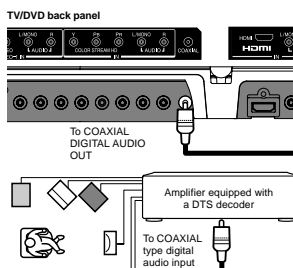

Connecting an HDMI™ or a DVI device to the HDMI input

The HDMI^[1] input on your TV/DVD receives digital audio and uncompressed digital video from an HDMI device or uncompressed digital video from a DVI^[2] device.

This input is designed to accept HDCP^[3] program material in digital form from EIA/CEA-861/861B-compliant^[4] consumer electronic devices (such as a set-top box or DVD player with HDMI or DVI output).

The HDMI input is designed for best performance with high definition video signals. It will accept and display 480i, 480p, 720p and 1080i signals.

Note: The HDMI jack is not intended for connection to and should not be used with a personal computer. For PC connection, see page 20.

To connect an HDMI device, you will need:

- one HDMI cable (type A connector)

For proper operation, it is recommended that you use as short an HDMI cable as possible. You should not encounter difficulty if you use an HDMI cable that is shorter than 16.4 ft (5m).

HDMI cable transfers both video and audio. Separate analog audio cables are not required (see illustration below).

You must set the HDMI audio input setting to "HDMI" in the AUDIO menu (see page 40).

Some CDVs (Video CDs) may not output digital audio signals. In that case, you may hear sound by connecting analog audio cables. If you do use analog audio cables for this reason, you will need to set the HDMI audio input setting to "DVI" to hear the analog audio (see page 40).
Note: If you connect an HDMI device and analog audio cables and play media with digital audio output, to hear digital audio you must set the HDMI audio input setting to "HDMI" (page 40).

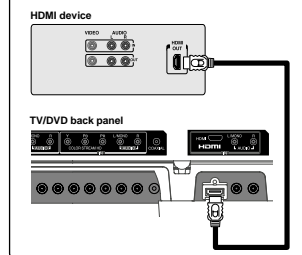

HDMI, the HDMI logo, and High-Definition Multimedia Interface are trademarks or registered trademarks of HDMI Licensing, LLC.

- [1] HDMI = High-Definition Multimedia Interface.
- [2] DVI = Digital Video Interface.
- [3] HDCP = High-bandwidth Digital Content Protection.
- [4] EIA/CEA-861/861B compliance covers the transmission of uncompressed digital video with high-bandwidth digital content protection, which is being standardized for reception of high-definition video signals.
Because this is an evolving technology, it is possible that some devices may not operate properly with the TV/DVD.

To ensure that the HDMI or DVI device is reset properly, it is recommended that you follow these procedures:

- When turning on your electronic components, turn on the TV/DVD first, and then the HDMI or DVI device.
- When turning off your electronic components, turn off the HDMI or DVI device first, and then the TV/DVD.

To connect a DVI device, you will need:

- one HDMI-to-DVI adapter cable (HDMI type A connector)

For proper operation, the length of an HDMI-to-DVI adapter cable should not exceed 9.8 ft (3m). The recommended length is 6.6 ft (2m).

- one pair of standard analog audio cables
- An HDMI-to-DVI adapter cable transfers only video. Separate analog audio cables are required (see illustration below).

You must set the HDMI audio input setting to "DVI" in the AUDIO menu (see page 40).

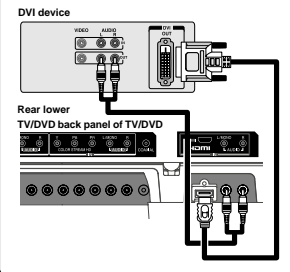

Connecting an amplifier equipped with an MPEG audio decoder

MPEG2 audio
You can enjoy motion picture and live concert DVD video discs encoded via the MPEG2 recording system with dynamic realistic sound by connecting an amplifier equipped with an MPEG2 audio decoder or MPEG2 audio processor.

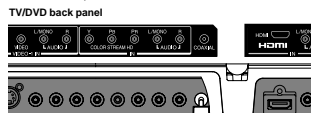

- You will need:
- one coaxial cable

- Notes:**
- Connect the COAXIAL DIGITAL AUDIO OUT jack of the TV/DVD to the "COAXIAL" input of a Receiver or Processor.
 - Refer to the owner's manual of the connected equipment as well.
 - The output sound of the TV/DVD has a wide dynamic range. Be sure to adjust the receiver's volume to a moderate listening level. Otherwise, the speakers may be damaged by a sudden high volume sound.
 - Turn off the amplifier before you connect or disconnect the TV/DVD's power cord. If you leave the amplifier power on, the speakers may be damaged.

Connecting an amplifier equipped with a digital audio input 2 channel digital stereo

You can enjoy the dynamic sound of 2 channel digital stereo by connecting an amplifier equipped with a digital audio input and speaker system (right and left front speakers).

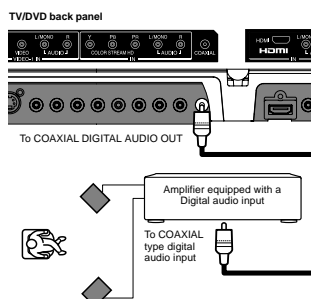

- You will need:
- one coaxial cable

- Notes:**
- PCM audio is limited to DVD or CD playback.
 - Connect the COAXIAL DIGITAL AUDIO OUT jack of the TV/DVD to the "COAXIAL" input of a Receiver or Processor.
 - Refer to the owner's manual of the connected equipment as well.
 - The output sound of the TV/DVD has a wide dynamic range. Be sure to adjust the receiver's volume to a moderate listening level. Otherwise, the speakers may be damaged by a sudden high volume sound.
 - Turn off the amplifier before you connect or disconnect the TV/DVD's power cord. If you leave the amplifier power on, the speakers may be damaged.

Adding channels to the TV/DVD's memory

When you press CH \wedge/\vee , your TV/DVD will stop only on the channels you have stored in the TV/DVD's channel memory. Follow the steps below to program channels into the channel memory.

Programming channels automatically

Your TV/DVD can automatically detect all active channels and store them in its memory. After the TV/DVD has stored the channels in its memory automatically, you can add or erase channels manually.

To add channels automatically:

1. Press MENU, then press \blacktriangleleft or \blacktriangleright to display the SETUP menu.
2. Press \blacktriangle or \blacktriangledown until the TV/CABLE selection is highlighted.
3. Press \blacktriangleleft or \blacktriangleright to highlight either TV or CABLE, depending on which you use.
If you use an antenna, choose TV.
If you use cable, choose CABLE.
4. Press \blacktriangledown until the CH PROGRAM selection is highlighted.
5. Press \blacktriangleright to start channel programming. The TV/DVD will automatically cycle through all the TV or Cable channels (depending on which you selected), and store all active channels in the channel memory. While the TV/DVD is cycling through the channels, the message "PROGRAMMING NOW-PLEASE WAIT" appears.
6. When channel programming is complete, the message "COMPLETED" appears.
7. Press CH \wedge/\vee to view the programmed channels.



Adding and erasing channels manually

After you have programmed the channels automatically, you can add or erase specific channels manually.

To add or erase channels manually:

1. Select the channel you want to add or erase. If adding channels, you must select the channel to add using the Channel Number buttons.
2. Press MENU, then press \blacktriangleleft or \blacktriangleright to display the SETUP menu.
3. Press \blacktriangle or \blacktriangledown to highlight ADD/ERASE.
4. Press \blacktriangleleft or \blacktriangleright to select ADD or ERASE, whichever function you want to perform.
5. Repeat steps 1-4 for other channels you want to add or erase.



Changing channels

To change to the next programmed channel:

Press Channel \wedge/\vee on the TV/DVD or CH \wedge/\vee on the remote control.

To change to a specific channel (programmed or unprogrammed):

Press the Channel Number buttons (0-9 and 100) on the remote control. For example, to select channel 125, press 100, 2, 5.

Game mode

After connecting a TV Game to the unit, press GAME. The TV screen changes to the Game mode.

- The Game mode screen is adjusted to the suitable brightness for your eyes.
- If GAME is pressed during standby mode, the unit turns on automatically and the Game mode screen appears on the screen.

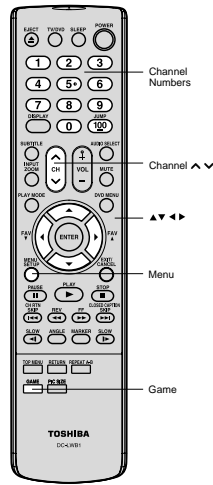

In addition to cycling through your programmed channels, the Channel \wedge/\vee buttons will also cycle through the video input sources (page 31) in the order illustrated below.



Using the TV/DVD's features

Adjusting the channel settings

Switching between two channels

You can switch between two channels without entering an actual channel number each time.

To switch between two channels:

1. Select the first channel you want to view.
2. Select a second channel using the Channel Number buttons (0-9, 100).
3. Press CH RTN. The previous channel will be displayed. Each time you press CH RTN, the TV/DVD will switch back and forth between the two channels.

Programming your favorite channels

You can preset up to 12 of your favorite channels using the Favorite Channel Programming feature. Because this feature scans through only your favorite channels, it allows you to skip other channels you do not normally watch.

You can still use CH \wedge/\vee to scan through all the channels you programmed in the TV's memory.

To program your favorite channels:

1. Select a channel you want to program.
2. Press MENU, then press \blacktriangleleft or \blacktriangleright to display the OPTION menu.
3. Press \blacktriangle or \blacktriangledown to highlight FAVORITE CH.



4. Press \blacktriangleright to display the FAVORITE CH menu. SET/CLEAR will be highlighted.

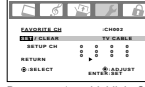

5. Press \blacktriangleleft or \blacktriangleright to highlight SET and press ENTER.
6. Press EXIT to return to normal viewing.
7. Repeat steps 1-6 for up to 12 channel.

To select your favorite channels:

Press the FAV $\blacktriangle/\blacktriangledown$ buttons on the remote control to select your favorite channels. The FAV $\blacktriangle/\blacktriangledown$ buttons will not work until you have programmed your favorite channels.

To clear your favorite channels:

1. Select a channel you want to clear.
2. Press MENU, then press \blacktriangleleft or \blacktriangleright to display the OPTION menu.
3. Press \blacktriangle or \blacktriangledown to highlight FAVORITE CH.
4. Press \blacktriangleright to display the FAVORITE CH menu. SET/CLEAR will be highlighted.
5. Press \blacktriangleleft or \blacktriangleright to highlight CLEAR.



6. Press ENTER until "0" replaces the channel number you want to erase.
7. Press EXIT to return to normal viewing.
8. Repeat steps 1-7 for the other channels.

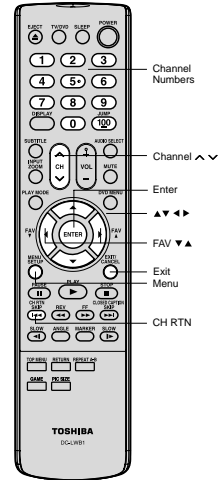

Using the LOCKS menu

Note: The V-Chip feature is available for the U.S. V-Chip system only. The Canadian V-Chip Feature system is not supported. You can prevent others from viewing certain programs or channels by blocking them using the V-Chip feature.

Selecting a password

Before you can use the V-Chip Feature to block programs and channels, you must select a password. The password you select prevents others from changing the rating limits you set.

To select your password and access the LOCKS menu:

1. Press MENU, then press \blacktriangleleft or \blacktriangleright to highlight the LOCKS menu.
2. Press \blacktriangle or \blacktriangledown to display the password entering mode.



3. Use the Channel Number buttons (0-9) to enter your password.



4. Enter the password again to confirm it, and then press ENTER. The LOCKS menu appears. If the wrong password is entered, "ERROR" blinks about 4 seconds.



5. You may now set up the LOCKS menu. See "Using the V-Chip (parental control) feature" (page 27), "Locking channels" (page 28), "Locking the video inputs" (page 28), "Setting the GameTimer™" (page 29) or "Using the panel lock feature" (page 29).

To change your password:

1. Press MENU, then press \blacktriangleleft or \blacktriangleright to display the LOCKS menu.
2. Press \blacktriangle or \blacktriangledown to display the password entering mode.
3. Use the Channel Number buttons (0-9) to enter your password. Press ENTER. The LOCKS menu appears.
4. Press \blacktriangle or \blacktriangledown to highlight NEW PASSWORD and press \blacktriangleright to display the NEW PASSWORD menu.
5. Use the Channel Number buttons (0-9) to enter a new code. Press ENTER.
6. Enter the password again to confirm it, and then press ENTER.
7. Press EXIT to return to normal viewing.

Note:

The password you programmed is also used in the LOCKS menu; see pages 27-29.

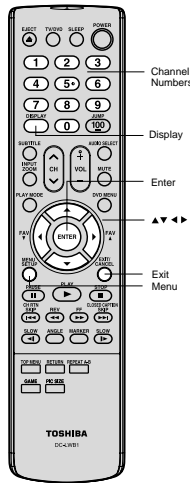

Note:

If you forget your password, press DISPLAY four times within five seconds while the TV/DVD is in password entering mode. This allows you to reset your password.

Using the V-Chip (parental control) feature

The Motion Picture Association of America (MPAA) uses a rating system to qualify motion picture content. Television broadcasters employ a rating system to qualify the content of television programs, as well. The TV and MOVIE ratings work with the V-Chip feature and allow you to block programs according to the rating limits you set.

To use the V-Chip to block programs by rating:

1. Press MENU, then press \blacktriangleleft or \blacktriangleright to display the LOCKS menu.
2. Press \blacktriangle or \blacktriangledown to display the password entering mode.
3. Use the Channel Number buttons (0-9) to enter your password. Press ENTER. The LOCKS menu appears.
4. Press \blacktriangle or \blacktriangledown to highlight V-CHIP.

• Press \blacktriangleleft or \blacktriangleright to highlight ON to enable V-Chip program blocking by rating.

- Press \blacktriangleleft or \blacktriangleright to highlight OFF to disable V-Chip program blocking by rating.

5. Press \blacktriangle or \blacktriangledown to highlight TV RATING. Then, press \blacktriangleleft or \blacktriangleright to display the desired rating.
 - OFF : TV RATING is not set
 - TV-Y : All children
 - TV-Y7 : 7 years old and above
 - TV-G : General audience
 - TV-PG : Parental guidance
 - TV-14 : 14 years old and above
 - TV-MA : 17 years old and above

• When you select TV-Y7, TV-PG, TV-14 or TV-MA, press DISPLAY to explain the rating. Press \blacktriangle or \blacktriangledown to select the desired rating you want.

- Press \blacktriangleleft or \blacktriangleright to select the setting "ON" or "OFF", then press ENTER.

6. Press \blacktriangle or \blacktriangledown to highlight MOVIE RATING. Then, press \blacktriangleleft or \blacktriangleright to display the desired rating.
 - OFF : MOVIE RATING is not set (no movies will be blocked)
 - G : All ages
 - PG : Parental guidance
 - PG-13 : Parental guidance less than 13 years old
 - R : Under 17 years old Parental guidance suggested
 - NC17 : 17 years old and above
 - X : Adult only

• When you are done selecting the ratings, press EXIT to return to normal viewing.

7. When you are done selecting the ratings, press EXIT to return to normal viewing.

When you try to view a program with a ratings block, a message will appear listing the program's ratings. The program can still be viewed if you press MUTE and then enter your password to temporarily bypass the block.

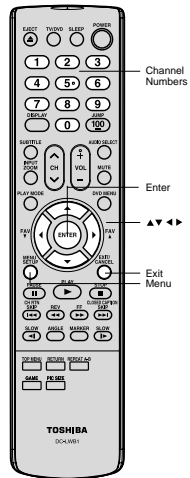

Locking channels

With the CH LOCK feature, you can lock specific channels. You will not be able to tune locked channels unless you clear the setting. You can choose to lock up to nine TV channels and nine cable channels.

- Use the Channel Number buttons (0-9 and 100) to display the television channel you wish to lock.
- Press MENU, then press ◀ or ▶ to display the LOCKS menu.
- Press ▲ or ▼ to display the password entering mode.
- Use the Channel Number buttons (0-9) to enter your password, then press ENTER. The LOCKS menu appears.
- Press ▲ or ▼ to highlight CH LOCK and press ▶ to display the CH LOCK menu.
- Press ◀ or ▶ to select the following:
 - SET— to set the channel as one to be locked. Then press ENTER.
 - CLEAR— to clear all channels from the list of locked channels. Then press ENTER.
- Repeat steps 1 through 6 to lock other channels. When you have finished locking channels, press EXIT to return to normal viewing.

If you try to tune a locked channel, the TV/DVD will not display it, but will display the nearest unlocked channel.

To unlock channels:

- Press MENU, then press ◀ or ▶ to display the LOCKS menu.
- Press ▲ or ▼ to display the password entering mode.
- Use the Channel Number buttons (0-9) to enter your password, then press ENTER. The LOCKS menu appears.
- Press ▲ or ▼ to highlight CH LOCK and press ▶ to display the CH LOCK menu.
- Press ◀ or ▶ to highlight CLEAR and clear all channels from the list of locked channels. Press ENTER.
- Press EXIT to return to normal viewing.

Locking the video inputs

With the VIDEO LOCK feature, you can lock out the input sources (VIDEO1, VIDEO2, COLORSTREAM HD, HDMI, PC, GAME) and channels 3 and 4. You will not be able to select the input sources with the INPUT button or Channel buttons unless you clear the setting.

To set up the video lock:

- Press MENU, then press ◀ or ▶ to display the LOCKS menu.
- Press ▲ or ▼ to display the password entering mode.
- Use the Channel Number buttons (0-9) to enter your password, then press ENTER. The LOCKS menu appears.
- Press ▲ or ▼ to highlight VIDEO LOCK and press ▶ to highlight VIDEO LOCK.
- Press ◀ or ▶ to select:
 - OFF: Unlocks all video input sources.
 - VIDEO: Locks VIDEO1, VIDEO2, COLORSTREAM HD, HDMI, PC, GAME.
 - VIDEO +: Locks VIDEO1, VIDEO2, COLORSTREAM HD, HDMI, PC, GAME, channel 3 and channel 4. This option should be used if you use the antenna terminal to play a video tape.
- Press EXIT to return to normal viewing.

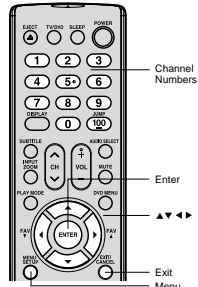

Note:
After programming CH LOCK, change channels before turning off the television.

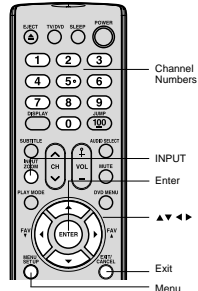

Note:
After programming VIDEO LOCK, change channels or press the INPUT key before turning off the TV/DVD.

To unlock the video inputs:

- Press MENU, then press ◀ or ▶ to display the LOCKS menu.
- Press ▲ or ▼ to display the password entering mode.
- Use the Channel Number buttons (0-9) to enter your password, then press ENTER. The LOCKS menu appears.
- Press ▲ or ▼ to highlight VIDEO LOCK and press ◀ or ▶ to highlight OFF.
- Press EXIT to return to normal viewing.

Setting the GameTimer™

With the GameTimer™ feature, you can automatically activate the VIDEO LOCK feature (VIDEO setting) to set a time limit for playing a video game (30, 60, 90 or 120 minutes).

To set up the GameTimer:

- Press MENU, then press ◀ or ▶ to display the LOCKS menu.
 - Press ▲ or ▼ to display the password entering mode.
 - Use the Channel Number buttons (0-9) to enter your password, then press ENTER. The LOCKS menu appears.
 - Press ▲ or ▼ to highlight GAME TIMER.
 - Press ◀ or ▶ to select a time limit (30 minutes, 60 minutes, 90 minutes, 120 minutes or OFF).
 - Press EXIT to return to normal viewing. After the GameTimer is programmed, the display will appear briefly every ten minutes to remind you that the GameTimer is operating.
- When the programmed time is reached, the TV/DVD will change channels automatically and enter VIDEO LOCK mode.



Using the panel lock feature

You can lock the top panel buttons to prevent your settings from being changed accidentally (by children, for example). When the panel lock is in ON, all control buttons on the TV/DVD top panel (except POWER) do not operate.

To lock the panel:

- Press MENU, then press ◀ or ▶ to display the LOCKS menu.
- Press ▲ or ▼ to display the password entering mode.
- Use the Channel Number buttons (0-9) to enter your password, then press ENTER. The LOCKS menu appears.
- Press ▲ or ▼ to highlight PANEL LOCK and press ▶ to highlight ON.

If a button on the top panel is pressed, the message "NOT AVAILABLE" appears.

To unlock the panel:

Press and hold the VOLUME - button on the TV/DVD top panel for about 10 seconds until the message "PANEL LOCK OFF" appears on-screen.

You also can unlock the panel using the menus:

- Press MENU, then press ◀ or ▶ to display the LOCKS menu.
- Press ▲ or ▼ to display the password entering mode.
- Use the Channel Number buttons (0-9) to enter your password, then press ENTER. The LOCKS menu appears.
- Press ▲ or ▼ to highlight PANEL LOCK, and then press ◀ or ▶ to highlight OFF.

Notes:

- Interactive video games that involve shooting a gun type of joy-stick at an on-screen target may not work on this TV/DVD.
- To deactivate the GameTimer, set the VIDEO LOCK to OFF (see "Locking the video inputs" page 28).

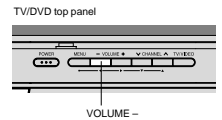
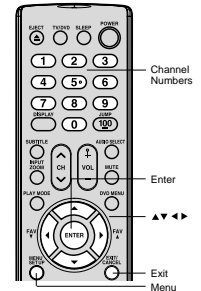

Labeling channels

Channel labels appear above the channel number display each time you turn on the TV/DVD, select a channel, or press the DISPLAY button. You can choose any four characters to identify a channel.

To create channel labels:

- Select a channel you want to label.
 - Press MENU, then press ◀ or ▶ until the OPTION menu appears.
 - Press ▲ or ▼ to highlight CH LABEL.
 - Press ▶ to display the CH LABEL menu. SET/CLEAR will be highlighted.
 - Press ◀ or ▶ to highlight SET.
 - Press ENTER to highlight LABEL.
 - Press ◀ or ▶ to enter a character in the first space. Press the button repeatedly until the character you want appears on the screen. Press ENTER.
 - Repeat step 7 to enter the rest of the characters.
- If you would like a blank space in the label name, you must choose an empty space from the list of characters; otherwise, a dash will appear in that space.
- Repeat steps 1-8 for other channels. You can assign a label to each channel.
 - Press EXIT to return to normal viewing.

Note:

The character will change as below.

◀ → 0...9 → A...Z
 → SPACE → + → -

To erase channel labels:

- Select a channel with a label.
- Press MENU, then press ◀ or ▶ until the OPTION menu appears.
- Press ▲ or ▼ to highlight CH LABEL.
- Press ▶ to display the CH LABEL menu. SET/CLEAR will be highlighted.
- Press ◀ or ▶ to highlight CLEAR.
- Press ENTER.
- Repeat steps 1-6 to erase other channel labels.

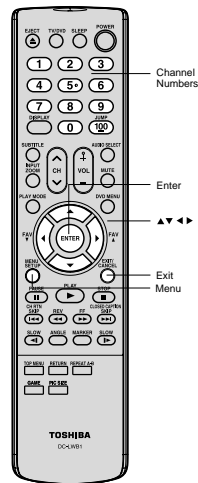

Selecting the video input source

Press INPUT to view a signal from another device connected to your TV/DVD, such as a VCR or DVD player. You can select ANT, VIDEO 1, VIDEO 2, ColorStream HD, HDMI or PC depending on which input jacks you used to connect your devices (see "Connecting your TV/DVD" on page 11).



Pressing INPUT on the remote control displays the current signal source (press INPUT again or 0-5 to change)

You also can use the Channel / buttons to select the video input source. In addition to cycling through your programmed channels (page 24), the Channel / buttons will also cycle through the video input sources, in the order illustrated below.



Labeling the video input sources

The video label feature allows you to label each input source for your TV/DVD from the following preset list of labels:

- : Uses the default label name
- VCR : Video cassette recorder
- DVD : DVD video
- DTV : Digital TV set-top box
- SAT : Satellite box
- CBL : Cable box

To label the video input sources:

- Press MENU, then press ◀ or ▶ to display the OPTION menu.
- Press ▲ or ▼ to highlight VIDEO LABEL.
- Press ▶ to display the VIDEO LABEL menu.
- Press ▲ or ▼ to highlight the video source you want to label.
- Press ◀ or ▶ to select the desired label for that input source.
- Press EXIT to return to normal viewing.

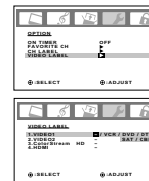

Setting the clock

You must set the clock before you can program the ON timer.

To set the clock: (Example: 8:30 AM)

- Press MENU, then press ◀ or ▶ to display the SETUP menu.
- Press ▲ or ▼ to highlight CLOCK SET.
- Press ▶ to highlight the hour position.
- Press ▲ or ▼ to set the hour, then press ▶ to highlight the minute position.
- Press ▲ or ▼ to set the minutes, then press EXIT to return to normal viewing.

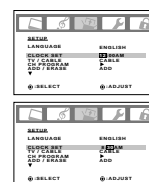

Note:

If the power source for the TV/DVD is interrupted (for example, the power cord is unplugged or a power failure occurs), you will need to reset the clock.

Setting the ON timer

This feature allows you to program the TV/DVD to turn on automatically at a set time. If you program the ON TIMER to "DAILY," the TV/DVD will turn on every day at the same time to the same channel until you clear the ON TIMER.

To set the on timer: (Example: Turning on the TV/DVD to channel 012 at 6:30 AM, DAILY)

1. Set the clock, if you have not already done so (see page 31).
2. Press MENU, then press ◀ or ▶ to display the OPTION menu.
3. Press ▲ or ▼ to highlight ON TIMER.
4. Press ◀ or ▶ to highlight SET, then press ENTER. The ON TIMER menu appears. Press ▶ to set the time.
5. Press ▲ or ▼ to set the desired hour, then press ▶.



6. Set the desired minutes and channel, as in step 5.



7. Press ▶ to select ONCE or DAILY.
8. Press EXIT to return to normal viewing.



To cancel the on timer:

1. Select CLEAR in step 7 above.
2. Press EXIT to return to normal viewing.

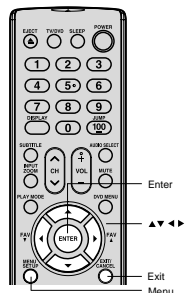

Note:
After a power failure or disconnection of the power, the timer settings will be lost.

32

Viewing the wide-screen picture formats (480i and 480p signals only)

You can view 480i and 480p format programs in a variety of picture sizes—Natural, TheaterWide, and Full.

The way the image displays in any of the picture sizes will vary depending on the format of the program you are viewing. Select the picture size that displays the current program the way that looks best to you.

Selecting the picture size

1. Press PIC SIZE on the remote control.
2. Press the corresponding number button (0-2) to select the desired picture size, as described below and on the next page.

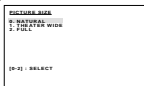

Natural picture size

- The image is displayed close to its originally formatted proportion. Some program formats will display with side bars and/or bars at the top and bottom.

Natural picture size example: The way the image displays will vary depending on the format of the program you are currently watching.

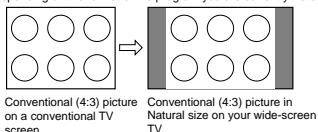

TheaterWide picture size (for 4:3 format programs)

- The center of the picture remains close to its original proportion, but the left and right edges are stretched wider to fill the screen.
- The top and bottom edges of the picture may be hidden.

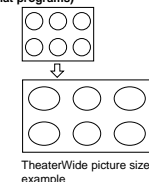

Full picture size (for 16:9 source programs)

- If receiving a 4:3 format program, the picture is stretched wider to fill the width of the screen, but not stretched taller.
- None of the picture is hidden.

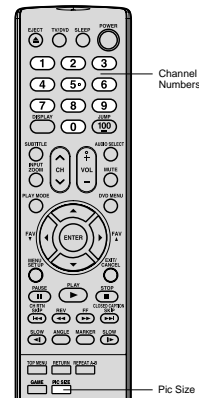
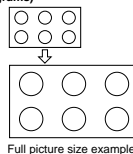

Note:
You also can change the picture size by selecting PICTURE SIZE in the SETUP menu.



Notes:

- The PICTURE SIZE feature is not available for some program formats (such as 1080i or 720p). Such formats will display in Full picture size.
- Using these functions to change the picture size (i.e., changing the height/width ratio) for any purpose other than your private viewing may be prohibited under the Copyright Laws of the United States and other countries, and may subject you to civil and criminal liability.

33

Selecting the cinema mode

When you view a DVD movie (3:2 pulldown processed) from a DVD player connected to the ColorStream (component video) inputs on the TV/DVD, smoother and more natural motion can be obtained by setting the CINEMA MODE to FILM.

To set the CINEMA MODE to FILM:

1. Press MENU, then press ◀ or ▶ until the SETUP menu appears.
2. Press ▲ or ▼ to highlight CINEMA MODE, then press ◀ or ▶ to select FILM.



To set the CINEMA MODE to VIDEO:

1. Press ◀ or ▶ to select VIDEO in step 2 above.

Using the ASPECT feature

When the ASPECT feature is set to ON and the TV/DVD receives a 480i signal, the picture size is automatically selected (as described in the following table).

Aspect ratio of signal source	Automatic aspect size (automatically selected when ASPECT is ON)
4:3 Normal	Natural
16:9 Full	Full
4:3 Letter box	TheaterWide
Not defined	User-set mode

If the signal does not include aspect information, the picture size you selected on pages 33 is displayed.

To turn on the ASPECT feature:

1. Press MENU, then press ◀ or ▶ until the SETUP menu appears.
2. Press ▲ or ▼ to highlight ASPECT, then press ◀ or ▶ to select ON.

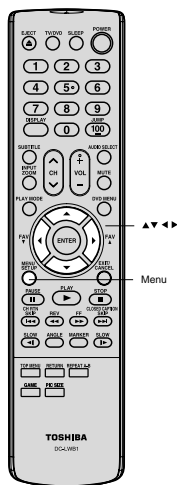

34

Setting the sleep timer

You can set the TV/DVD so it turns off automatically.

To set the sleep timer:

Repeatedly press SLEEP on the remote control to set the length of time until the TV/DVD turns off. The clock will increase 10 minutes for each press of the SLEEP button (0h00m, 0h10m, ...1h50m, 2h00m). After the sleep timer is programmed, the display will appear briefly every ten minutes to remind you that the sleep timer is operating.

To confirm the sleep timer setting:

Press SLEEP one time. The remaining time will be momentarily displayed.

To cancel the sleep timer:

Repeatedly press SLEEP until the display turns to 0h00m.

Using the closed caption feature

The Closed Caption feature has two options:

- Captions**—An on-screen display of the dialogue, narration, and sound effects of programs and videos that are closed-captioned (usually identified in your local TV listing as "CC").
- Text**—An on-screen display of information not related to the program, such as weather or stock data (if available in your viewing area).

To view captions or text:

1. Tune the TV/DVD to the desired program.
2. Press MENU, then press ◀ or ▶ to display the SETUP menu.
3. Press ▲ or ▼ to highlight CLOSED CAPTION.



4. Press ◀ or ▶ to select the desired Closed Caption mode, as follows:

- To view captions, select C1 or C2 (C1 displays translation of the primary language in your area).
Note: If the program or video you selected is not closed-captioned, no captions will display on-screen.
- To view text, select T1 or T2.
Note: If text is not available in your viewing area, a black rectangle may appear on-screen. If this happens, set the Closed Caption feature to OFF.
- To turn the Closed Caption feature off, highlight OFF in the Closed Caption menu.

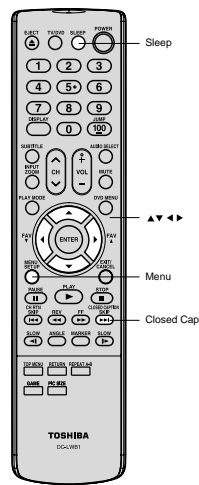

Notes:

- A closed caption signal may not be decoded in the following situations:
 - when a video tape has been dubbed
 - when the signal reception is weak
 - when the signal reception is non-standard
- You also can use the CLOSED CAPTION button to view caption or text.

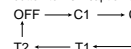

35

Adjusting the picture

Selecting the picture mode

You can select four picture modes—Sports, Standard, Movie, and Memory—as described in the following table:

Mode	Picture Quality
SPORTS	Bright and dynamic picture (factory-set)
STANDARD	Standard picture quality (factory-set)
MOVIE	Movie-like picture setting (factory-set)
MEMORY	Your personal preferences (set by you; see "Adjusting the picture quality")

To select the picture mode:

1. Press MENU, then press ◀ or ▶ to display the PICTURE menu.
2. Press ▲ or ▼ to highlight MODE.



3. Press ◀ or ▶ to highlight the mode you prefer.
4. Press EXIT to return to normal viewing.

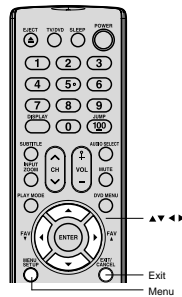

Adjusting the picture quality

You can adjust the picture quality to your personal preferences, including the brightness, contrast, color, tint, and sharpness. The qualities you choose will be stored automatically in your TV/DVD's memory so you can recall them at any time.

To adjust the picture quality:

1. Press MENU, then press ◀ or ▶ to display the PICTURE menu.
2. Press ▲ or ▼ until the item you want to adjust is highlighted.



3. Press ◀ or ▶ to adjust the level.

Selection	◀ Pressing	▶ Pressing
BRIGHTNESS	darker	lighter
CONTRAST	lower	higher
COLOR	paler	deeper
TINT	reddish	greenish
SHARPNESS	softer	sharper

4. Press EXIT to return to normal viewing.

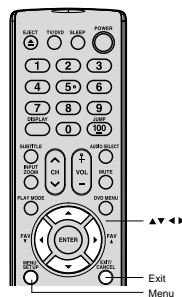

36

Adjusting the sound

Muting the sound

Press MUTE to temporarily turn off the sound. While the sound is off, the screen will display the word MUTE in the lower right-hand corner. To restore the sound, press MUTE again.

Selecting stereo/SAP broadcasts

The multi-channel TV sound (MTS) feature provides high-fidelity stereo sound. MTS also can transmit a second audio program (SAP) containing a second language or other audio information.

Note: The MTS feature is not available in VIDEO mode.

When the TV/DVD receives a stereo or SAP broadcast, the word "STEREO" or "SAP" displays on-screen every time you turn the TV/DVD on, change the channel, or press DISPLAY.

To listen to stereo sound:

1. Press MENU, then press ◀ or ▶ to display the AUDIO menu.
2. Press ▲ or ▼ to highlight MTS.
3. Press ◀ or ▶ to highlight STR (stereo).

Notes:

- In general, you can leave your TV/DVD in stereo mode because the TV/DVD automatically outputs the type of sound being broadcast (stereo or mono).
- If the stereo sound is noisy, select MONO to reduce the noise.

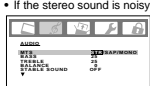

4. Press EXIT to return to normal viewing.

To listen to a second audio program (SAP):

1. Press MENU, then press ◀ or ▶ to display the AUDIO menu.
2. Press ▲ or ▼ to highlight MTS.
3. Press ◀ or ▶ to highlight SAP. The TV/DVD speakers will output the second audio program instead of normal audio.
4. Press EXIT to return to normal viewing.

Adjusting the sound quality

You can change the sound quality of your TV/DVD by adjusting the bass, treble, and balance.

To adjust the sound quality:

1. Press MENU, then press ◀ or ▶ until the AUDIO menu appears.
2. Press ▲ or ▼ to highlight the item you want to adjust.



3. Press ◀ or ▶ to adjust the level.

- ◀ makes the sound quality weaker or decreases the balance in the right channel, depending on the item selected.
- ▶ makes the sound quality stronger or decreases the balance in the left channel, depending on the item selected.

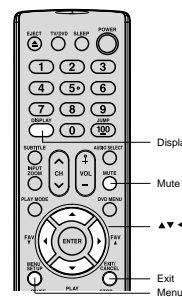

Note:

A second audio program (SAP) can be heard only on those TV stations that offer it.

For example, a station might broadcast music as a second audio program. If you have SAP on, you will see the current program on the screen but hear music instead of the program's normal audio.

However, if you have SAP on, and the station you are watching is not currently broadcasting a second audio program, the station's normal audio will be output; however, occasionally there is no sound at all in SAP mode. If this happens, set the MTS feature to STEREO mode.

Note:

Adjusting the sound quality (bass, treble and balance) does not affect the sound that is output from the headphone jack.

38

Using the CableClear® feature

CableClear® reduces visible interference in your TV/DVD picture. This is useful when receiving a broadcast with a weak signal (especially a Cable channel) or playing a video cassette or disc damaged by repeated use.

To turn on the CableClear® feature:

1. Press MENU, then press ◀ or ▶ to display the PICTURE menu.
2. Press ▲ or ▼ to highlight CableClear.



3. Press ◀ or ▶ to select ON.

To turn off the CableClear® feature:

1. Select OFF in step 3.

Selecting the color temperature

Change the picture quality by selecting from three preset color temperatures—cool, medium, and warm—as described in the following table:

Mode	Picture Quality
COOL	Blueish
MEDIUM	Neutral
WARM	Reddish

To select the color temperature:

1. Press MENU, then press ◀ or ▶ to display the PICTURE menu.
2. Press ▲ or ▼ to highlight COLOR TEMPERATURE.



3. Press ◀ or ▶ to highlight the mode you prefer.
4. Press EXIT to return to normal viewing.

Resetting your picture adjustments

The RESET function returns your picture quality adjustments to the following factory settings:

Mode sports	Tint center (0)
Brightness center (25)	Sharpness center (25)
Contrast max (50)	Color temperature cool
Color center (25)		

To reset your picture adjustments:

1. Press MENU, then press ◀ or ▶ to display the PICTURE menu.
2. Press ▲ or ▼ to highlight RESET, and then press ▶.

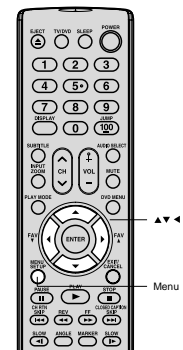
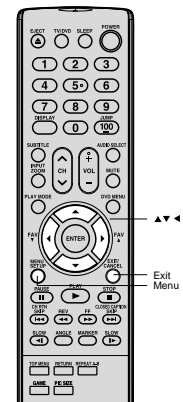

37

Resetting your audio adjustments

The RESET function returns the audio adjustments to the following factory settings:

Bass center (25)
Treble center (25)
Balance center (0)

To reset your audio adjustments:

1. Press MENU, then press ◀ or ▶ to display the AUDIO menu.
2. Press ▲ or ▼ to highlight RESET, and then press ▶.



Using the StableSound® feature

The StableSound feature limits the highest volume level to prevent extreme changes in volume when the signal source is changed.

To turn on the StableSound® feature:

1. Press MENU, then press ◀ or ▶ to display the AUDIO menu.
2. Press ▲ or ▼ to highlight STABLE SOUND.
3. Press ◀ or ▶ to highlight ON.



To turn off the StableSound® feature:

1. Highlight OFF in step 3 above.

Using the WOW™ surround sound feature

WOW is a special combination of SRS Labs audio technologies that creates a thrilling surround sound experience with deep, rich bass from stereo sound sources. Your TV/DVD's audio will sound fuller, richer, and wider. WOW consists of three features: SRS 3D, FOCUS, and TruBass.

To adjust the WOW feature:

1. Select STEREO mode (see "selecting stereo/SAP broadcasts" on page 38).
2. Press MENU, then press ◀ or ▶ to display the AUDIO menu.
3. Press ▼ or ▲ to highlight the desired WOW feature you want to adjust.
 - SRS 3D — To turn on or off the surround sound effect.
 - FOCUS — To turn on or off the vocal emphasis effect.
 - TruBass — To select your desired bass expansion level (HIGH, LOW or OFF).



4. Press ◀ or ▶ to adjust the item.

WOW, SRS and (S) symbol are trademarks of SRS Labs, Inc. WOW technology is incorporated under license from SRS Labs, Inc.

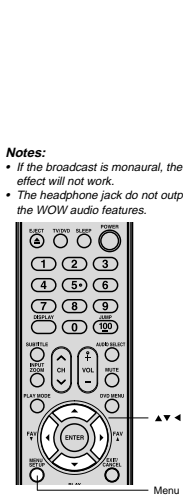
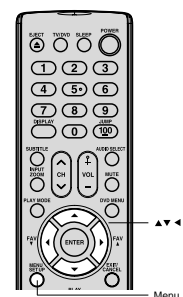

Notes:

- If the broadcast is monaural, the SRS 3D effect will not work.
- The headphone jack do not output any of the WOW audio features.

39

Selecting the HDMI audio input source

See page 17 for details on connecting an HDMI or a DVI device to the TV/DVD's HDMI input. If you connect a DVI device, to hear audio you must also connect the analog audio cables to the HDMI audio IN jacks (see page 17). Set the HDMI audio input setting to "DVI" with this connection. If you connect an HDMI device and play media with digital audio output, to hear digital audio set the HDMI audio input setting to "HDMI" with this connection. If you connect an HDMI device but play media with analog audio output (for example, certain DVDs do not output digital audio), to hear audio you must also connect the analog audio cables to the HDMI audio IN jacks (see page 17). Set the HDMI audio input setting to "DVI" with this connection.

To select the HDMI audio input source:

1. Press MENU, then press ◀ or ▶ to display the AUDIO menu.
2. Press ▼ or ▲ to highlight HDMI.
3. Press ◀ or ▶ to select HDMI or DVI.

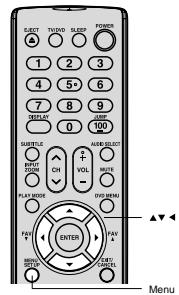

Adjusting the back lighting feature

If your TV/DVD is in a bright room, the screen image may be difficult to see. You can use the BACK LIGHTING feature to adjust the screen brightness for improved picture clarity.

To adjust the back lighting:

1. Press MENU, then press ◀ or ▶ until the SETUP menu appears.
2. Press ▲ or ▼ to highlight BACK LIGHTING.



3. Press a ◀ or ▶ to adjust the screen brightness.

Displaying on-screen information

Press DISPLAY to display the following on-screen information:

- Clock
- Channel number or Video input mode selected
- Channel label (if preset)
- Stereo or SAP (second audio program) audio status
- Content rating
- On timer, Sleep timer (if preset)
- Picture Size



Note:

The cold cathode fluorescent lamp used for the back light on this TV/DVD has a limited life. When areas on the screen darken, flicker, or no longer light up, the lamp may be at the end of its life. Contact your nearest Toshiba Authorized Service Station.

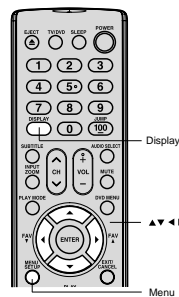

Auto power off

The TV/DVD will automatically turn off after approximately 15 minutes if it is tuned to a vacant channel or a station that completes its broadcast for the day and stops broadcasting on that channel. This feature does not work in Video input/PC/DVD mode.

Understanding the Power Return feature

If the power is cut off while you are viewing the TV/DVD and the power is resupplied, the Power Return feature will turn the TV/DVD on automatically.

If the power is going to be off for a long time or you are going to be away from home for a long time, unplug the power cord from the wall outlet to prevent the TV/DVD from turning on in your absence.

Picture/Audio adjustments in the PC mode

There are a number of picture settings you can adjust to optimize the performance of the unit in PC mode.

PICTURE Menu AUDIO Menu



Example: Adjust the contrast.

1. During PC mode, press MENU, then press ◀ or ▶ to display the PICTURE menu.
2. Press ▲ or ▼ to select CONTRAST.
3. Press ◀ or ▶ to adjust CONTRAST.
4. Press EXIT to return to normal viewing.

DESCRIPTION ABOUT EACH SETTING OPTION

- PICTURE menu**
- BRIGHTNESS:** To adjust the brightness of PC Monitor screen.
- CONTRAST:** To adjust the contrast of PC Monitor screen.
- HOR POSITION:** To adjust the horizontal position of the image on the PC Monitor screen. Each video standard will require a different value for this setting.
- VER POSITION:** To adjust the vertical position of the image on the PC Monitor screen. Each video standard will require a different value for this setting.
- PHASE:** This must be adjusted after the frequency has been set to optimize picture quality.
- CLOCK:** To minimize any vertical bars or stripes visible on the screen background.
- RED/GREEN/BLUE:** To adjust the color temperature of the PC Monitor screen.
- WXGA INPUT:** Set to ON, when you select the WXGA mode on the PC.
- AUDIO menu**
- BASS/TREBLE/BALANCE:** To adjust the sound quality of PC mode.
- STABLE SOUND:** To turn on or off the StableSound® feature in PC mode.
- WOW SRS 3D:** To turn on or off the surround effect in PC mode.
- WOW FOCUS:** To turn on or off the vocal emphasis effect in PC mode.
- WOW TruBass:** To select your desired bass expansion level (HIGH, LOW or OFF) in PC mode.

Resetting your picture/audio adjustments in the PC mode

The RESET function returns your picture quality adjustments to the following factory settings:

PICTURE menu	AUDIO menu
Brightness center (25)	Bass center (25)
Contrast max (50)	Treble center (25)
Red center (25)	Balance center (0)
Green center (25)	
Blue center (25)	

To reset your picture adjustments:

1. Press MENU during PC mode.
2. Press ◀ or ▶ to select the desired menu.
3. Press ▲ or ▼ to highlight RESET, and then press ▶.

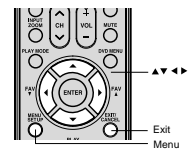

Notes:

- If you wish to change the on-screen language, follow the steps 1-3 on page 23.
- If no buttons are pressed for more than approx. 60 seconds, the PC Monitor Menu screen will return to normal Monitor screen automatically.
- The PC Monitor Menu settings are not effective for normal TV mode, DVD mode or external input mode.

DVD Playback

Playing a disc

This section shows you the basics on how to play a disc.

Basic playback DVD VCD CD

Preparations: When connecting to other equipment, turn the power off.

1. Press POWER on the unit or on the remote control to turn on the unit. The Power indicator will light.
 - Every time you press POWER, the TV/DVD starts from TV mode.
 - When using an amplifier, switch on the amplifier.
2. Press TV/DVD on the remote control to select DVD mode. The DVD startup screen will appear on the screen. (If DVD disc has already loaded, playback will start automatically.)

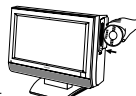

3. Load the disc in the disc slot with the label side facing forward. (If the disc has a label.) Hold the disc without touching either of its surfaces, align it with the guides, and place it in position.

Note:

4. When you playback the 8cm disc, you need an adapter (not supplied).



- A menu screen will appear on the TV screen, if the disc has a menu feature. Press ▲/▼ or ◀/▶ to select title, then press ENTER. Title is selected and play commences.

5. Press VOL + or - to adjust the volume.



6. Press STOP to end playback.

Resume feature

- Depending on the disc you are playing, when you press STOP one time, the TV/DVD remembers the scene that was playing (▶ appears on screen). Press PLAY to resume playback from the stopped scene.
- If you press STOP again or eject the disc, the unit will clear the stopped scene (■ appears on screen).

CAUTION
Keep your fingers well clear of the disc slot when disc is loading or unloading. Neglecting to do so may cause serious personal injury.

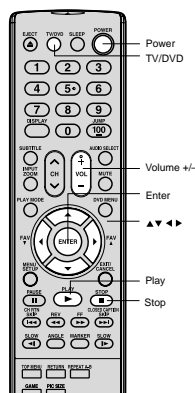

Note:

Static electricity may affect the DVD player's operation and cause it to not work properly. If this happens, turn OFF the POWER, disconnect and then reconnect the AC power cord, and turn ON the unit again.

About DVD VCD CD

The DVD VCD CD icons on the heading bar show the playable discs for the function described under that heading.

DVD: You can use this function with DVD video discs.

VCD: You can use this function with Video CDs.

CD: You can use this function with Audio CDs and CD-R/RW discs.

To start playback in the stop mode

Press PLAY.

To pause playback (still mode)

Press PAUSE during playback. To resume normal playback, press PLAY. • The sound is muted during still mode.

To stop playback

Press STOP.

To remove the disc

Press EJECT. Remove the disc after the disc comes out.

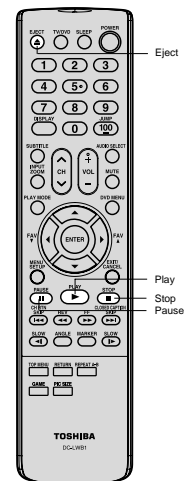

Notes:

- If a non-compatible disc is loaded, "Incorrect Disc", "Region Code Error" or "Parental Error" will appear on the TV screen according to the type of loaded disc. In this case, check your disc again (see pages 8 and 57).
- Some discs may take a minute or so to start playback.
- If you insert a single-sided disc the wrong way, "Reading" will appear on the display for about 1 minute and then "Incorrect Disc" will continue to be displayed.
- Some discs may not resume playing the same scene after stopping.
- Resuming cannot function when you play a PBC-featured Video CD while the PBC is on. To turn off the PBC, see page 51.
- Some playback operations of DVDs may be intentionally fixed by software producers. Since this unit plays DVDs according to the disc contents the software producers designed, some playback features may not be available. Also refer to the instructions supplied with the DVDs.
- Do not move the unit during playback. Doing so may damage the disc.
- Use EJECT on the unit to unload and eject the disc. Do not push the disc while it is moving. Doing so may cause the unit to malfunction.
- Do not put any objects other than discs in the disc slot. Doing so may cause the unit to malfunction.
- When you press a button, there may be a slight delay before the function activates.

Playing in fast reverse or fast forward directions

DVD VCD CD

- Press REV or FF during playback.
- REV: Fast reverse playback
- FF: Fast forward playback
- Each time you press REV or FF, the playback speed changes.

To resume normal playback
Press PLAY.

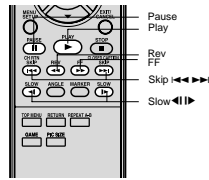

Notes:

- The TV/DVD mutes sound and subtitles during reverse and forward scan of DVD video discs. However, the TV/DVD plays sound during fast forward or fast reverse play of audio CDs.
- The playback speed may differ depending on the disc.

Playing frame by frame

DVD VCD
Press PAUSE during still playback. Each time you press PAUSE, the picture advances one frame.

To resume normal playback
Press PLAY.

Playing in slow-motion

Press SLOW ◀ (REVERSE) or ▶ (FORWARD) during playback. Each time you press the button, the slow-motion speed changes.

To resume normal playback
Press PLAY.

Locating a chapter or track

DVD VCD CD
Press SKIP ◀ or ▶ repeatedly to display the chapter or track number you want. Playback starts from the selected chapter or track.

SKIP ▶▶: To locate succeeding chapters or tracks.

SKIP ◀◀: Playback starts from the beginning of the current chapter or track. When you press twice in quick succession, playback starts from the beginning of the preceding chapter or track.

Note:

The sound is muted during frame by frame playback.

Notes:

- The sound is muted during slow-motion playback.
- The Video CD cannot play Reverse Slow.

Note:

A "Prohibition" symbol may appear at the upper left of the screen. This symbol means either the feature you tried is not available on the disc, or the TV/DVD cannot access the feature at this time. This does not indicate a problem with the TV/DVD.

44

Marking desired scenes

The unit stores the points that you want to watch again up to 3 points. You can resume playback from each scene.

Marking the scenes

- Press MARKER during playback.
- Select the blank Marker using ▲ or ▼. Then press ENTER at the desired scene.
 - Repeat this procedure to set the other 2 scenes.
- Press MARKER to remove this display.

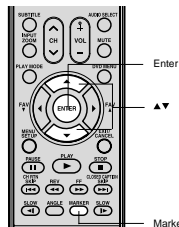
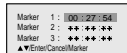

Notes:

- Some discs may not work with the marking operation.
- The marking is canceled when you eject the disc or turn the power off.
- Some subtitles recorded around the marker may fail to appear.

Returning to the scenes

- Press MARKER during playback or stop mode.
- Press ▲ or ▼ to select the Marker 1-3.
- Press ENTER. Playback starts from the marked scene.

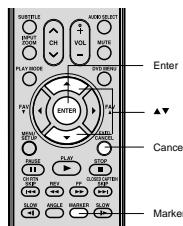
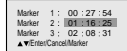
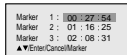

To cancel the Marker

Follow the above steps 1-2, then press CANCEL.

46

Zooming

This unit will allow you to zoom in on the frame image. You can then make selections by switching the position of the frame.

- Press ZOOM during playback. The center part of the image will be zoomed in. Each press of ZOOM will change the ZOOM Q1 (x 1.3), Q2 (x 1.5) and Q3 (x 2.0).
- Press ▲/▼/◀/▶ to view a different part of the frame. You may move the frame from the center position to UP, DOWN, LEFT or RIGHT direction.
- In the zoom mode press ZOOM repeatedly to return to a 1:1 view (Q Off).

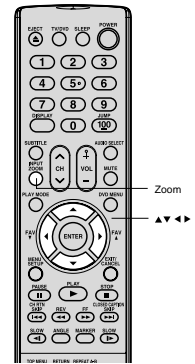
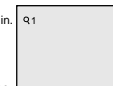

Notes:

- You can select the Pause, Slow or Search playback in the zoom mode.
- Some discs may not respond to zoom feature.

Locating desired scene

Use the title, chapter and time recorded on the disc to locate the desired point to play back. To check the title, chapter and time, press DISPLAY.

- Press JUMP during playback or stop mode.

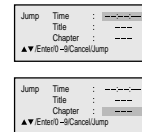

- Press ▲ or ▼ to select the "Time", "Title" or "Chapter".

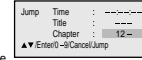

- Press Number buttons (0-9) to change the number.
 - If you input a wrong number, press CANCEL.
 - Refer to the package supplied with the disc to check the numbers.

- Press ENTER. Playback starts.
 - When you change the title, playback starts from Chapter 1 of the selected title.
 - Some discs may not work in the above operation.

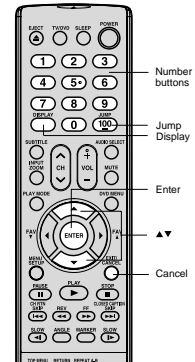

Note:

In case of the Video-CD playback with PBC, the JUMP does not work. To turn off PBC, see page 51.

45

Repeat playback

- Press PLAY MODE during playback or stop mode.
- Press ◀/▶ or ENTER once or twice to select "Chapter" or "Title". The unit automatically starts repeat playback after finishing the current title or chapter.

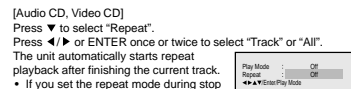

- Press PLAY MODE again to make the screen disappear.

To resume normal playback
Select Repeat : "Off" in step 2.

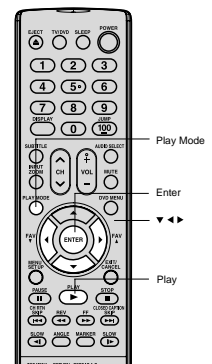

Notes:

- Some discs may not work with the repeat operation.
- In case of Video CD with PBC, repeat functions are prohibited during playback.

A-B Repeat playback

A-B repeat playback allows you to repeat material between two selected points.

- Press REPEAT A-B during playback. The start point is selected.



- Press REPEAT A-B again.

The end point is selected. Playback starts at the point that you selected. Playback stops at the end point, returns to Point A automatically, then starts again.



To resume normal playback

Press REPEAT A-B again. "Off" appears on the screen.

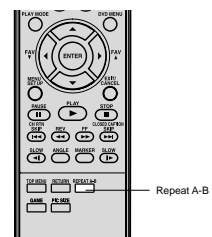

Notes:

- In A-B Repeat mode, subtitles near the A or B locations may not be displayed.
- You cannot set the A-B Repeat for the scenes that include multiple angles.
- A-B Repeat playback does not work when Repeat playback is activated.
- You may not be able to set A-B Repeat, during certain scenes of the DVD.
- A-B Repeat does not work with an interactive DVD, MP3/WMA/JPEG CD.
- A-B Repeat is prohibited when PBC is on.

47

Program playback (VCD CD)

You can arrange the playback order of tracks or files on the disc.

1. Press PLAY MODE in the stop mode.

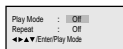

2. Press ▲ or ▼ to select Play Mode, then press ◀▶ or ENTER to select "Program".

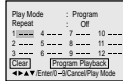

3. Press ▲/▼/◀▶ to select the programming position. Use Number buttons (0-9) to input the Track or file numbers.
 - To program others, repeat step 3.
 - If you input a wrong number, press CANCEL.



4. Press ▲/▼/◀▶ to select "Program Playback" and press ENTER. The programs you selected will start to playback in the order.
 - In case of JPEG file, press SKIP ▶▶▶ to continue the program playback.
 - To resume normal playback, select Play Mode: "Off" in step 2.

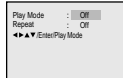

To change the program

1. In the program mode, press ▲/▼/◀▶ to select the track number.
2. Press Number buttons (0-9) to select the track number to be replaced.

To clear the program one by one

- In the program mode, press ▲/▼/◀▶ to select the track number. Then press CANCEL.

To clear all the programs

- In the program mode, press ▲/▼/◀▶ to select "Clear". Then press ENTER.

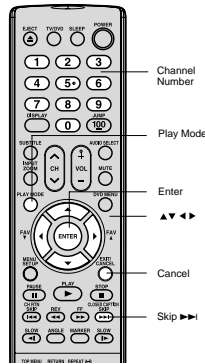

Note:
The program is cancelled when you eject the disc or turn the power off.

Random playback (VCD CD)

The unit selects tracks or files at random and playback.

1. Press PLAY MODE during playback or stop mode.
2. Press ▲/▼ to select Play Mode, then press ◀▶ or ENTER to select "Random".
3. Press PLAY. The Random Playback will start.
 - If you set "Random" during playback mode, Random playback will begin after the track that is currently being played has ended.
 - To resume normal playback, select Play Mode: "Off" in step 2.

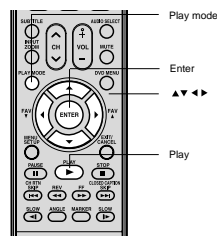
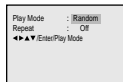

Note:
In playing back the Video CD with PBC, you cannot set Random playback.

48

Changing angles (DVD)

When playing back a disc recorded with multi-angle facility, you can change the angle that you are viewing the scene from.

1. Press ANGLE during playback. The current angle will appear.

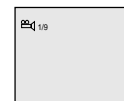

2. Press ANGLE repeatedly until the desired angle is selected.

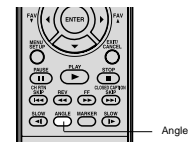

Note:
Depending on the DVD, you may not be able to change the angles even if multi-angles are recorded on the DVD.

Title selection (DVD)

Two or more titles are recorded on some discs. If the title menu is recorded on the disc, you can select the desired title.

1. Press TOP MENU during playback. Title menu appears on the screen.
2. Press ▲/▼/◀▶ to select the desired title.
3. Press ENTER or PLAY. The playback of the selected title will start.

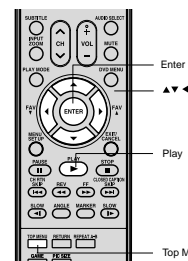

Note:
Depending on the DVD, you may not be able to select the title. Depending on the DVD, a "title menu" may simply be called a "menu" or "title" in the instructions supplied with the disc.

DVD menu (DVD)

Some DVDs allow you to select the disc contents using the menu. When you playback these DVDs, you can select the subtitle language and sound-track language, etc. using the menu.

1. Press DVD MENU during playback. The DVD menu appears on the screen.
 - Press DVD MENU again to resume playback at the scene when you pressed DVD MENU.
2. Press ▲/▼/◀▶ to select the desired item.
3. Press ENTER. The menu continues to another screen. Repeat steps 2 and 3 to set the item completely.

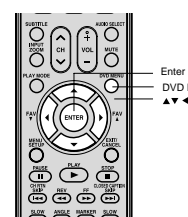

Note:
Depending on the DVD, you may not be able to resume playback from the scene point when you pressed DVD MENU.

49

Changing soundtrack language (DVD VCD)

You can select the language when you play a multilingual disc.

1. Press AUDIO SELECT during playback. The current soundtrack language will appear.
2. Press AUDIO SELECT repeatedly until the desired language is selected.
 - The on screen display will disappear after a few seconds.

In case of Video CD playback

Audio type changes as follows each time you press AUDIO SELECT.

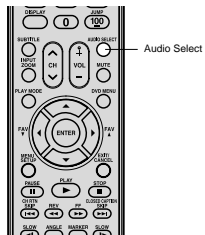
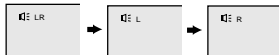

Notes:

- If the desired language is not heard after pressing the button several times, the language is not recorded on the disc.
- Changing soundtrack language is cancelled when you eject the disc. The initial default language or available language will be heard if the disc is played back again.
- If you select DTS in playing DTS-encoded disc, no sound will be heard from the TV/ DVD's speakers.

Subtitles (DVD)

When playing back a disc recorded with subtitles, you can select the subtitle language or turn the subtitle off.

1. Press SUBTITLE repeatedly during playback until your desired language appears.
2. To turn off the subtitle, press subtitle until "Off" appears.
 - The on screen display will disappear after a few seconds.

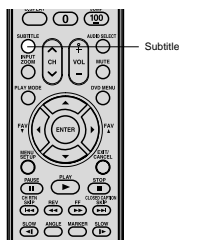

Notes:

- Depending on the DVD, you may not be able to change subtitles, or to turn subtitles on or off.
- While playing a DVD, the subtitle may change when you loaded or eject the disc.
- In some cases, a selected subtitle language may not be changed immediately.

50

Karaoke playback (DVD)

You can turn the vocal on or off recorded on the DVD KARAOKE.

1. During DVD KARAOKE disc playback, press AUDIO SELECT. The KARAOKE symbol (K) appears.
 - If you play non-Karaoke disc, the KARAOKE symbol (K) does not appear.
 - Some Karaoke discs may not have the vocal on/off function. In this case, the KARAOKE symbol (K) does not appear.
2. Press ◀ or ▶ to select "On" or "Off".
 - On : The primary vocal is output when it is recorded on the disc.
 - Off : The primary vocal is not output.
 - The on screen display will disappear after a few seconds.

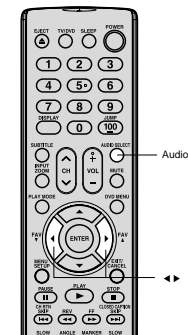
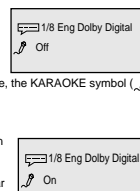

Notes:

- The vocal output feature is used during playback of Dolby Digital (multi-channel) recorded DVD KARAOKE discs. This feature allows you to turn off vocal audio tracks, or restore them for background accompaniment.
- When playing Karaoke, connect appropriate audio equipment such as an amplifier to the TV/DVD.

Disc status (DVD VCD CD)

With each press of DISPLAY, the status of the disc will appear on the screen and change as follows.

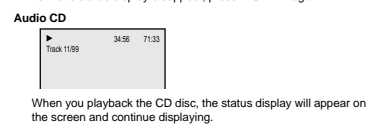
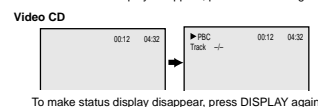

To turn off the PBC (VCD)

Press number button 1 in the stop mode, then press ENTER.

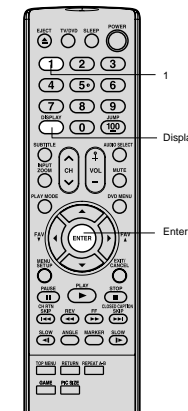

51

MP3/WMA/JPEG CD operation

This unit can play back MP3/WMA/JPEG-data which has been recorded on CD-R or CD-RW. To produce MP3/WMA/JPEG-data, you need a Windows-PC with CD-R/RW drive and MP3/WMA/JPEG-encoding Software (not supplied).
Files recorded on an Apple® HFS (hierarchical file system) volume cannot be played.

MP3/WMA/JPEG CD information

Limitations on MP3/WMA/JPEG CD playback

- MP3/WMA/JPEG CDs must meet ISO9660 standards. Files must have one of the following extensions: .mp3, .wma, or .jpg.
- This unit can read 200 files per disc. If one directory has more than 200 files, the unit will read up to 200 files and any additional files will be ignored.
- The unit is able to recognize up to a maximum of 50 directories per disc.
- MP3/WMA/JPEG CDs cannot be used for the purpose of recording.
- If the CD has both audio tracks and MP3/WMA/JPEG files, only audio tracks are played.
- It may take more than one minute for this unit to read MP3/WMA/JPEG files depending on its structure.
- Music recorded by "Joliet Recording Specification" can be played back, the file name is displayed (within 16 letters) on the screen. Long file names will be condensed.
- Music files recorded on an Apple® HFS (hierarchical file system) volume cannot be played.

Limitations on display

- The maximum number for display is 16 letters.
- Available letters for display are the following:
capital or small alphabets of A through Z, numbers of 0 through 9, and _ (underscore).
- Other letters than those above are replaced in hyphen.

Notes on MP3/WMA/JPEG files

To play back MP3/WMA/JPEG CD in the recorded order,

- Use MP3/WMA/JPEG software that records data alphabetically or numerically.
- Name each file including two-digit or three-digit number (ex. "01" "02" or "001" "002").
- Refrain from making too many sub-folders.

Notice:

- Some MP3/WMA/JPEG CDs cannot be played back depending on the recording conditions.
- The CD-R/RW that has no music data or non MP3/WMA/JPEG files cannot be played back.

Standard, sampling frequency, and the bit rate:

MP3 CD

MPEG-1 Audio
32kHz, 44.1kHz, 48kHz
32kbps ~ 320kbps (constant bit rate or variable bit rate)
The recommend recording setting for a high-quality sound is 44.1kHz of sampling frequency and 128kbps of constant bit rate.

WMA CD

WMA version 7, and 8
32kHz, 48kbps
44.1kHz, 48kbps ~ 192kbps
48kHz, 128kbps ~ 192kbps
The file recorded by mono, 48kHz, 48 kbps is not available to this unit.

The DVD player contained in this LCD TV requires discs/recordings to meet certain technical standards in order to achieve optimal playback quality. Pre-recorded DVDs are automatically set to these standards. There are many different types of recordable disc formats (including CD-R containing MP3/WMA files). Because this area of technology is still evolving, Toshiba has not guaranteed that all recordable discs will produce optimal playback quality. The technical criteria set forth in this owner's manual are meant only as a guide.

Please be advised that you must obtain permission from the applicable copyright owners to download copyrighted content, including music files, in any format, including the MP3 and WMA formats, prior to the downloading thereof. Toshiba has no right to grant and does not grant permission to download any copyrighted content.

Apple is a registered trademark of Apple Computer, Inc.

52

MP3/WMA CD playback

- Load a disc on which MP3 or WMA files have been recorded in the disc slot.
- A file menu screen will appear on the screen.
Press **◀/▶** or **ENTER** to select folder.
- Press **▲/▼/◀/▶** or Number buttons (0-9) to select the desired file.
 - In case the folder includes more than 15 files, press **◀** or **▶** to display next file list.
- When **PLAY** has been pressed after displaying the file menu, playback begins automatically starting from the first file. In this case, if the first file is an MP3/WMA file, only MP3/WMA files are played back in order. If the first file is a JPEG file, the first JPEG file is played back.
- Press **ENTER**.
The selected file starts playing back.
- Press **STOP** to end playback.
 - The unit records the stopped point. **■** appears on the screen.
 - Press **PLAY** to resume playback (from the scene point).
 - If you press **STOP** again or unload the disc, the unit will clear the stopped point.

About file menu

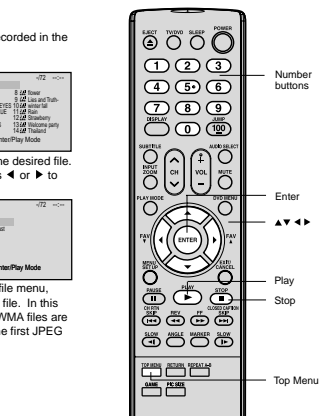
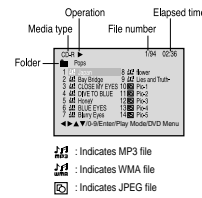

Notes:

- During MP3/WMA/JPEG playback, you cannot use **JUMP**, **A-B Repeat** functions.
- You can use **Repeat (Track or All)**, **Random** functions and **Program** playback for MP3/WMA/JPEG CD playback (see pages 47 and 48).
- In the case of a CD containing a mixture of MP3, WMA and JPEG files, the files are played back by selecting them from the file menu.

Notes:

- The picture menu is displayed when the **FUJICOLOR CD** or the **Kodak Picture CD** are played. To display the file menu, press **TOP MENU**.
- In the case of a CD containing a mixture of MP3, WMA and JPEG files, the files are played back by selecting them from the file menu.
- MP3 or WMA file on the **Kodak Picture CD** is not recognized on this unit.

53

JPEG CD playback

You can select your desired JPEG file on the file menu and picture menu. The selected JPEG file is automatically adjusted to the TV screen. (When the aspect ratio of a JPEG file is different from that of the TV screen, black bars may appear at the top, bottom, and/or sides of the screen.)

- Load a disc on which JPEG files have been recorded in the slot.
- A file menu screen will appear on the screen. Press **◀/▶** to select folder.
- Press **▲/▼/◀/▶** or Number buttons (0-9) to select the desired file. To display a picture menu, press **DVD MENU**. (To return to a file menu, press **TOP MENU**.)
Press **◀/▶/▲/▼** to select the desired file.
 - To display next list, press **SKIP**.
 - When **PLAY** has been pressed after displaying the file menu, playback begins automatically starting from the first file. In this case, if the first file is a JPEG file, the first JPEG file is played back. If the first file is an MP3/WMA file, only MP3/WMA files are played back in order.
- Press **ENTER**. The selected picture appears on the screen.

Rotating an image

You can rotate an image by 90 degrees by pressing **ANGLE** during playback of the image.

"**▲**", "**■**", "**▼**" or "**◀**" appears briefly on the screen.

- Press **STOP** to end playback.
The file menu appears on the screen.
If you want to watch the other file, repeat steps 3 - 4.

Slide show playback

The slide show enables you to view pictures (files) one after another automatically.

Preparation:

- Set "JPEG Interval" setting to "5 Seconds", "10 Seconds" or "15 Seconds". (See page 56.)

- Select your desired starting file for the slide show in the step 3 on the above.
- Press **ENTER** to start slide show from the selected file.
 - If you press **PAUSE** during the slide show, the slide show stops temporarily. "**||**" appears briefly on the picture.
 - If the picture appears upside down or sideways, press **ANGLE** repeatedly until it's right side up.
 - "**▲**", "**■**", "**▼**" or "**◀**" appears briefly on the screen.
 - Press **PLAY** or **SKIP** again to resume the slide show.
 - When slide show playback is finished, the file list appears.
 - To stop the slide show, press **STOP**. The file list appears.

54

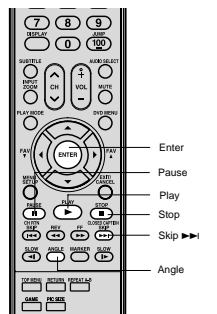
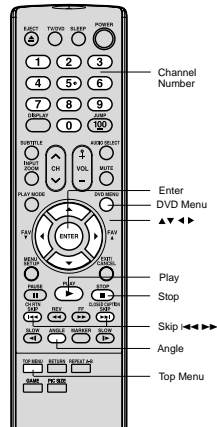

DVD function setup

Customizing the function settings

You can change the default settings of the DVD mode to customize performance to your preference.

Setting procedure

- Press **SETUP** during stop mode.
The following on-screen display appears.
- Press **▶** or **▶** to select the desired section, then press **▼** or **ENTER**.
- Press **▲** or **▼** to select the desired option.
- Change the selection using **▲/▼/◀/▶** or **ENTER** (see "Setting details" on pages 56 and 57).
 - Repeat step 3 and 4 to change other settings.
 - Press **▲** to select another operation, go back to step 2.
- To make **SETUP** screen disappear, press **SETUP** or **RETURN**.

Section	Option	Details	Page
Language	Menu	To select the language of "Menu", "Subtitle" and "Audio" if their languages are recorded on the disc in more than one language.	56
	Subtitle		
Picture	TV Screen	To select a picture size.	56
	Display	To turn on or deactivate the operational status display on the screen.	
	JPEG interval	To select a preferred setting for the slide show playback.	
Sound	Select Files	To select your desired file type for playing back a disc containing a mixture of MP3, WMA, and JPEG files.	57
	DRC	To select On or Off for DRC (Dynamic Range Control).	
Parental	Password	Input 4-digit password to set the parental level.	57
	Parental	To select a preferred parental level for the parental setting.	
Other	OSD Language	To select a preferred language for on screen display.	

55

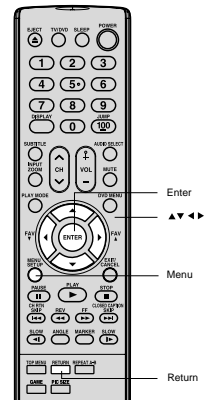

Setting details

Language



Menu, Subtitle, Audio

You can select the language of "Menu", "Subtitle" and "Audio" if more than one language is recorded onto the disc.

English, Francais, Espanol:

The selected language will be heard or seen.

Other:

Other language can be selected (see the "Language code list" page 59).

Original: (Audio)

The unit will select the first priority language of each disc.

Automatic: (Subtitle)

- The unit will automatically select the same language in the AUDIO setting.
- When the unit selects the same language as the AUDIO, the subtitles will not appear during playback.
- When you do not use the same language as the AUDIO, the subtitles will appear during playback.

Off: (Subtitle)

Subtitles do not appear.

Note:

If the selected language is not recorded on the disc, the first-priority language is selected.

Picture

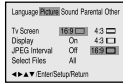

TV Screen

You have the following screen sizes to choose from:

4:3 Letter box:

When playing back a wide screen-DVD disc, it displays the wide picture with black bands at the top and bottom of screen.

4:3 Pan scan:

It displays the wide picture on the whole screen with left and right edges automatically cut off.

16:9 Wide:

A wide screen picture is displayed full size.

Note:

If the DVD disc is not formatted in the pan & scan style, it displays 4:3 style.

Display

On screen display can be switched on or off when you press the buttons.

On: On screen displays appear when you press the buttons (factory setting).

Off: On screen displays do not appear when you press any buttons.

JPEG Interval

You can continuously play back all JPEG files automatically. After the setting below, start playing the disc on which JPEG files have been recorded.

Off:

Plays back one file at a time.

5 Seconds:

Plays back images in the form of a slide show at 5 second intervals.

10 Seconds:

Plays back images in the form of a slide show at 10 second intervals.

15 Seconds:

Plays back images in the form of a slide show in 15 second intervals.

Select Files

When playing back a CD containing a mixture of MP3, WMA and JPEG files, only MP3/WMA or JPEG files can be displayed on the file menu.

All:

Displays all files.

Music Only:

Displays only MP3/WMA files.

Pictures Only:

Displays only JPEG files.

56

Setting details

Sound

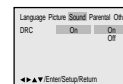

DRC

DRC (Dynamic Range Control) enables you to control the dynamic range so as to achieve a suitable sound for your equipment.

On: Loud sound such as explosion or similar is toned down slightly when played back. This makes it suitable for when it is connected to a stereo.

Off: It plays back at the recording level on the disc.

Notes:

- This function works only during playback of Dolby Digital recorded discs.
- The level of Dynamic Range Reduction may differ depending on DVD video disc.

Parental

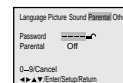

Parental control setting

Some discs are specified not suitable for children. Such discs can be limited not to play back with the unit.

- Press **▲** or **▼** to select "Parental", then press **◀** or **▶** until the level you require appears.

Level Off: The parental control setting does not function.

Level 8: Virtually all DVD software can be played back.

Level 1: DVD software for adults cannot be played back.

Select from the level 1 to level 8. The limitation will be more severe as the level number is lower.

- Press **▲** or **▼** to select "Password". Press Number buttons (0-9) to input a 4-digit password. Be sure to remember this number!

If you input a wrong number, press CANCEL.

- Press ENTER to store the password.

Note: Now the rating is locked and the setting cannot be changed unless you enter the correct password.

Notes:

- Depending on the discs, the unit cannot limit playback.
- Some discs may not be encoded with specific rating level information though its disc jacket says "adult." For those discs, the age restriction will not work.

To change the parental level

- Press **▲** or **▼** to select "Password".
- Press Number buttons (0-9) to enter the password you have stored.
- Press ENTER.
- Press **▲** or **▼** to select "Parental", then press **◀** or **▶** to change the parental level.
- Press **▲** or **▼** to select "Password", then press Number buttons (0-9) to enter the password. Note: You can change the password if you want.
- Press ENTER. Now the parental level is changed and locked.

If you forget the password...

- Press EJECT.
- Remove the disc after the screen comes out.
- "No Disc" appears on the screen.
- While holding STOP down on the top of the unit, press 7 on the remote control. "PASSWORD CLEAR" appears on the screen.
- Enter a new password again.

Other



OSD Language

The setup language can be selected.

English:

To display OSD language in English.

Francais:

To display OSD language in French.

Espanol:

To display OSD language in Spanish.

Note:

After completing the setup on pages 56 and 57, the settings will be retained in the memory (especially with DVD discs), even if you turn off the power.

57

Temporary disabling of parental level by DVD disc

Depending on the DVD disc, the disc may try to temporarily cancel the parental level that you have set. It is up to you to decide whether to cancel the rating level or not.

- Load a DVD disc.

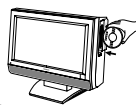

- If the DVD disc has been designed to temporarily cancel the Rating level, the screen which follows the "Reading" screen will change, depending on which disc is played. If you select "YES" with the ENTER key, "Your disc exceeds the parental control level" screen will then appear.

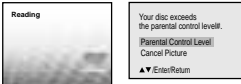

- If you wish to cancel the set rating level temporarily, select "Parental Control Level" with **▲** or **▼**, then press ENTER. If the 4-digit password at step 2 on page 57 has been set, the password entering screen will appear as shown in step 4. Alternatively, if the password has not been set, playback will commence. If you don't know (or have forgotten) the password, select "Cancel Picture". The setting screen will disappear. Press EJECT on the unit to remove the disc.

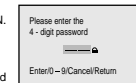

- Enter the password with Number buttons (0-9). Then press ENTER. To exit from the entry, press RETURN.

- Playback will commence if the entered password was correct.

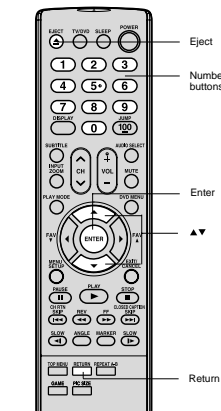

Note:

This temporary cancellation of rating level will be kept until the disc is ejected. When the disc is ejected, the original parental level will be set again automatically.

58

Appendix

Language code list

Enter the appropriate code number for the initial settings "Menu", "Subtitle" and/or "Audio." See page 56.

Language Name Code	Language Name Code	Language Name Code	Language Name Code
Abkhazian	1112	Fiji	1620
Afar	1111	Finnish	1619
Afrikaans	1116	French	1628
Albanian	2927	Frisian	1635
Amharic	1123	Galician	1722
Arabic	1128	Georgian	2111
Armenian	1835	German	1415
Assamese	1129	Greek	1522
Aymara	1135	Greenlandic	2122
Azerbaijani	1136	Guarani	1724
Bashkir	1211	Gujarati	1731
Basque	1531	Hausa	1811
Bengali, Bangla	1224	Hebrew	1933
Bhutani	1436	Hindi	1819
Bihari	1218	Hungarian	1831
Breton	1228	Icelandic	1929
Bulgarian	1217	Indonesian	1924
Burmese	2335	Interlingua	1911
Byelorussian	1215	Irish	1711
Cambodian	2123	Italian	1930
Catalan	1311	Japanese	2011
Chinese	3618	Javanese	2033
Corsican	1325	Kannada	2124
Croatian	1828	Kashmiri	2129
Czech	1329	Kazakh	2121
Danish	1411	Kirghiz	2135
Dutch	2422	Korean	2125
English	1524	Kurdish	2131
Esperanto	1525	Laotian	2225
Estonian	1530	Latin	2211
Faroese	1625	Latvian, Lettish	2232
		Lingala	2224
		Lithuanian	2230
		Macedonian	2321
		Malagasy	2317
		Malay	2329
		Malayalam	2322
		Maltese	2330
		Maori	2319
		Marathi	2328
		Moldavian	2325
		Mongolian	2324
		Nauru	2411
		Nepali	2415
		Norwegian	2425
		Oriya	2528
		Panjabi	2611
		Pashto, Pushto	2629
		Persian	1611
		Polish	2622
		Portuguese	2630
		Quechua	2731
		Rhaeto-Romance	2823
		Romanian	2825
		Russian	2831
		Samoan	2923
		Sanskrit	2911
		Serbian	2928
		Serbo-Croatian	2918
		Shona	2924
		Sindhi	2914
		Slovak	2921
		Slovenian	2922
		Somali	2925
		Spanish	1529
		Sundanese	2931
		Swahili	2933
		Swedish	2932
		Tagalog	3022
		Tajik	3017
		Tamil	3011
		Tatar	3030
		Telugu	3015
		Thai	3018
		Tibetan	1225
		Tigrinya	3019
		Tonga	3025
		Turkish	3028
		Turkmen	3021
		Twí	3033
		Ukrainian	3121
		Urdu	3128
		Uzbek	3136
		Vietnamese	3219
		Volapük	3225
		Welsh	1335
		Wolof	3325
		Xhosa	3418
		Yiddish	2019
		Yoruba	3525
		Zulu	3631

59

Appendix

Troubleshooting

Before calling a service technician, please check the following table for a possible cause of the symptom and some solutions.

Symptom	Solution
TV will not turn on	<ul style="list-style-type: none"> Make sure the connection of the AC adapter and AC cord, then press POWER. The remote control batteries may be dead. Replace the batteries.
No picture, no sound	<ul style="list-style-type: none"> Check the antenna/cable connections. The sound may be muted. Press VOLUME. The station may have broadcast difficulties. Try another channel. The MTS feature may be in SAP mode. Select STR or MONO in the MTS menu.
No sound, picture OK	<ul style="list-style-type: none"> The station may have broadcast difficulties. Try another channel. The MTS feature may be in SAP mode. Select STR or MONO in the MTS menu.
Poor sound, picture OK	<ul style="list-style-type: none"> The station may have broadcast difficulties. Try another channel. The MTS feature may be in SAP mode. Select STR or MONO in the MTS menu.
Poor picture, sound OK	<ul style="list-style-type: none"> Check the antenna connections. The station may have broadcast difficulties. Try another channel. Adjust the PICTURE menu.
Picture and sound are out of sync	<p>As with all products that contain a digital display, in rare instances, when viewing certain content (e.g., television broadcasts, video games, DVD), you may notice that the sound and picture are slightly out of sync. This phenomenon can be caused by various factors including, without limitation, video processing within the TV, video processing in an attached gaming system, and video processing/different compression rates used by broadcasters in their programming. You may want to try one or more of the following suggestions, which may help to reduce the effect of this phenomenon:</p> <ul style="list-style-type: none"> If the TV is connected to an external A/V device (e.g., DVD player, video game system, set-top-box, etc.) always try to use the Color Stream video jacks and corresponding audio jacks or the HDMI input (if available on your TV) for connection to such external A/V device. If the TV is connected to an A/V receiver that has a programmable audio delay feature, use this feature to help synchronize the sound to the picture. If connected to a video game system and your TV has the Game Mode feature (see owner's manual for more information), enable this feature. If you notice this phenomenon only on certain TV channels, please contact your local broadcast, cable, or satellite provider to inform them of this issue.
Poor reception of broadcast channels	<ul style="list-style-type: none"> The station may have broadcast difficulties. Try another channel. Check the antenna connections.
Cannot receive above channel 13	<ul style="list-style-type: none"> Make sure TV/CABLE is set to CABLE mode.
Unable to select a certain channel	<ul style="list-style-type: none"> The channel may be blocked by the V-Chip feature or CH LOCK feature, or erased with the add/erase feature.
Cannot access signal input sources (Video1, Video2, ColorStream HD, HDMI and PC) and/or Channels 3 and 4	<ul style="list-style-type: none"> Check the VIDEO LOCK feature.
Multiple images	<ul style="list-style-type: none"> The station may have broadcast difficulties. Try another channel. Use a highly directional outdoor antenna.
Poor color or no color	<ul style="list-style-type: none"> The station may have broadcast difficulties. Try another channel. Adjust the TINT and/or COLOR in the PICTURE menu.
Black box on screen	<ul style="list-style-type: none"> Select OFF in the Closed Caption menu to turn off the Closed Caption Text mode.
No stereo or SAP sound from a known MTS broadcast	<ul style="list-style-type: none"> Make sure the MTS feature is set properly (AUDIO menu).
The V-Chip password does not work (U.S. V-Chip system only)	<ul style="list-style-type: none"> Change or reset your password.
The remote control does not operate	<ul style="list-style-type: none"> Remove all obstructions between the remote control and the TV. The remote control batteries may be dead. Replace the batteries.
The top panel buttons do not operate	<ul style="list-style-type: none"> Check the PANEL LOCK feature.

60

Troubleshooting (continued)

Symptom of DVD	Solution
Playback doesn't start	<ul style="list-style-type: none"> No disc is loaded. The disc may be dirty. Clean the disc. The unit cannot play CD-ROMs, etc.
No picture	<ul style="list-style-type: none"> TV/DVD selector is not set correctly.
No sound	<ul style="list-style-type: none"> Make sure the input selector of the amplifier is set properly. The unit is in the special playback mode. Select the correct Audio Output/Input position on AV amplifier.
Picture is distorted during fast reverse/forward playback	<ul style="list-style-type: none"> The picture will be distorted occasionally.
Stopping playback, search, slow-motion play, repeat play, or program play, etc. cannot be performed	<ul style="list-style-type: none"> Some discs may not perform certain functions.
No on-screen display	<ul style="list-style-type: none"> Select Display On.
No surround sound	<ul style="list-style-type: none"> The setup does not match your stereo system.
The unit or remote operation key is not functioning	<ul style="list-style-type: none"> Turn off the unit and unplug the AC power cord for several minutes, then replug it.
Playback does not start when the title is selected	<ul style="list-style-type: none"> Check the Parental level setup.
Audio soundtrack and/or subtitle language is not changed when you play back a DVD	<ul style="list-style-type: none"> Multilingual language is not recorded on the DVD disc.
No subtitle	<ul style="list-style-type: none"> Some discs have no subtitles. Subtitles are cleared. Press SUBTITLE.
Angle cannot be changed	<ul style="list-style-type: none"> Multi-angles are not recorded on the DVD discs.
appears on the screen	<ul style="list-style-type: none"> The function is prohibited with the unit or the disc.

61

Specifications

- Notes:**
- This model complies with the specifications listed below.
 - Designs and specifications are subject to change without notice.
 - This model may not be compatible with features and/or specifications that may be added in the future.

	17HLV85	20HLV85
Television		
LCD panel	17.1 inches (434.4 mm diagonal) (Screen size is approximate.)	20.04 inches (508.9 mm diagonal) (Screen size is approximate.)
Display method	Color TFT LCD	
Number of pixels	1280 (Horizontal) x 768 (Vertical)	1366 (Horizontal) x 768 (Vertical)
Television system	NTSC standard	
Tuner type	F-Synth	
Channel coverage	VHF: 2 - 13 UHF: 14 - 69 Cable TV: 4A, A-5 - A-1, A-1, J - W, W+1 - W+84	
Antenna input	VHF/UHF 75 ohm	
Power source	120V AC, 60 Hz with supplied AC adapter	100 W with supplied AC adapter
Power consumption	65 W with supplied AC adapter	2.5 W x 2.5 W
Audio power	1.5 W x 1.5 W	1.8 x 3.9 inches (45.7 x 99.1 mm), 16 ohm x 2
Speaker type	1.5 x 2.7 inches (38.1 x 68.6 mm), 16 ohm x 2	
Video/Audio terminals	S-VIDEO INPUT Y-INPUT: 1V (p-p), 75 ohm, negative sync., Mini DIN 4pin x 1 C-INPUT: 0.286V (p-p) (burst signal), 75 ohm VIDEO/AUDIO INPUT VIDEO: 1V (p-p), 75 ohm, negative sync., pin jack x 2 AUDIO: 150 mV (rms) (30% modulation equivalent), 47k ohm), pin jack (LR) x 5 ColorStream® (component video) INPUT Y: 1V (p-p), 75 ohm P+: 0.7V (p-p), 75 ohm P-: 0.7V (p-p), 75 ohm DIGITAL AUDIO OUTPUT (Coaxial) DVD mode only 0.5V (p-p), 75 ohm, pin jack (LR) x 1 HEADPHONE 03.5mm stereo mini jack x 1 HDMI INPUT: HDMI compliant (type A connector) HDCP compliant E-EDID* compliant Suggested scan rates: 1080i, 480p, 480i, 720p HDMI Audio: 2-channel PCM 32/44.1/48 kHz sampling frequency 16/20/24 bits per sample PC Monitor Input Mini-Sub 15pin x 1	
Dimensions	Width: 17-15/16 inches (456 mm) Height: 16-1/8 inches (409 mm) Depth: 8-11/16 inches (220 mm)	Width: 21-13/16 inches (554 mm) Height: 17-5/8 inches (448 mm) Depth: 8-11/16 inches (220 mm)
Weight	17.6 lbs. (8.0 kg)	19.8 lbs. (9.0 kg)
Supplied accessories	Remote control (DC-LWB1) with two size "AAA" batteries AC adapter AC cord (for AC adapter) Owner's Manual (This booklet)	
DVD/CD Player		
Signal system	NTSC	
Applicable disc	1. DVD (12cm, 8cm [with Disc adapter]) 2. CD (12cm, 8cm [with Disc adapter])	
Pickup	1-Lens, 2-Beams System	

* E-EDID = Enhanced-Extended Display Identification.

WARNING: Always use the Toshiba wall bracket specified below or another wall bracket approved by Toshiba for wall mounting this television. The use of any wall bracket other than the Toshiba wall bracket specified below or another wall bracket approved by Toshiba for wall mounting this television could result in serious bodily injury and/or property damage. In the U.S.: Use Toshiba wall bracket model number **FWB2027**. For more information, call TACP's Consumer Solutions Center at 1-800-631-3811 or visit TACP's website at www.tacp.toshiba.com. In Canada: Call TCL's Customer Service Department at 1-800-268-3404.

62

Limited United States Warranty

LCD TV/DVD Combination - Depot Repair Warranty

Toshiba America Consumer Products, L.L.C. ("TACP") makes the following limited warranties to original consumers in the United States. THESE LIMITED WARRANTIES EXTEND TO THE ORIGINAL CONSUMER PURCHASER OR ANY PERSON RECEIVING THIS LCD TV/DVD COMBINATION AS A GIFT FROM THE ORIGINAL CONSUMER PURCHASER AND TO NO OTHER PURCHASER OR TRANSFEREE.

LCD TV/DVD COMBINATIONS PURCHASED IN THE U.S.A. AND USED ANYWHERE OUTSIDE OF THE U.S.A., INCLUDING, WITHOUT LIMITATION, CANADA AND MEXICO, ARE NOT COVERED BY THESE WARRANTIES.

LCD TV/DVD COMBINATIONS PURCHASED ANYWHERE OUTSIDE OF THE U.S.A., INCLUDING, WITHOUT LIMITATION, CANADA AND MEXICO, AND USED IN THE U.S.A., ARE NOT COVERED BY THESE WARRANTIES.

Limited One (1) Year Warranty on Parts and Labor
TACP warrants this LCD TV/DVD Combination and its parts against defects in materials or workmanship for a period of one (1) year after the date of original retail purchase. DURING THIS PERIOD, TACP WILL, AT TACP'S OPTION, REPAIR OR REPLACE A DEFECTIVE PART WITH A NEW OR REFURBISHED PART WITHOUT CHARGE TO YOU.

Rental Units

The warranty for LCD TV/DVD Combination rental units begins on the date of the first rental or thirty (30) days after the date of shipment to the rental firm, whichever comes first.

Commercial Units

LCD TV/DVD Combinations sold and used for commercial purposes have a limited warranty for all parts and labor, which warranty begins on the date of original retail purchase and ends on the date that is ninety (90) days thereafter.

Owner's Manual and Product Registration Card

Read this owner's manual thoroughly before operating this LCD TV/DVD Combination.

Complete and mail the enclosed product registration card or register your LCD TV/DVD Combination on-line at <http://www.tacp.toshiba.com/register> as soon as possible. By registering your LCD TV/DVD Combination you will enable TACP to bring you new products specifically designed to meet your needs and help us to contact you in the unlikely event a safety notification is required under the U.S. Consumer Product Safety Act. Failure to complete and return the product registration card does not diminish your warranty rights.

Your Responsibility
THE ABOVE WARRANTIES ARE SUBJECT TO THE FOLLOWING CONDITIONS:

- You must retain your bill of sale or provide other proof of purchase.
- All warranty servicing of this LCD TV/DVD Combination must be made by the Depot Warranty Repair Center specified by the TACP Consumer Solutions Center.
- The warranties from TACP are effective only if the LCD TV/DVD Combination is purchased and operated in the Continental U.S.A. or Puerto Rico.
- Labor service charges for set installation, setup, adjustment of customer controls, and installation or repair of antenna systems are not covered by this warranty. Reception problems caused by inadequate antenna systems, misaligned satellite dishes, cable television distribution, VCRs, DVD players/recorders,

personal computer level IEEE-1394 devices, and any other connected signal source device are your responsibility.

- Warranties extend only to defects in materials or workmanship as limited above, and do not extend to any LCD TV/DVD Combination or parts that have been lost or discarded by you or to damage to the LCD TV/DVD Combination or parts caused by fires, misuse, accident, Acts of God (such as lightning or fluctuations in electric power), improper installation, improper maintenance, or use in violation of instructions furnished by TACP; use or malfunction through simultaneous use of the LCD TV/DVD Combination and connected equipment; or to units that have been modified or had the serial number removed, altered, defaced, or rendered illegible.

How to Obtain Warranty Services

If, after following all of the operating instructions in this manual and checking the section "Troubleshooting," you find that service is needed:

- For instructions on how to obtain warranty service for your LCD Television, contact TACP's Consumer Solution Center toll free at 1-800-575-5469.
- You must include a copy or original bill of sale or other proof of purchase along with the entire LCD TV/DVD Combination to the Depot Warranty Repair Center specified by the TACP Consumer Solutions Center. You are responsible for all inbound transportation and insurance charges for the LCD TV/DVD Combination to the Depot Warranty Repair Center specified by the TACP Consumer Solutions Center.

For additional information, visit TACP's website:

www.tacp.toshiba.com

ALL WARRANTIES IMPLIED BY THE LAW OF ANY STATE OF THE U.S.A., INCLUDING THE IMPLIED WARRANTIES OF MERCHANTABILITY AND FITNESS FOR A PARTICULAR PURPOSE, ARE EXPRESSLY LIMITED TO THE DURATION OF THE LIMITED WARRANTIES SET FORTH ABOVE. WITH THE EXCEPTION OF ANY WARRANTIES IMPLIED BY THE LAW OF ANY STATE OF THE U.S.A. AS HEREBY LIMITED, THE FOREGOING WARRANTY IS EXCLUSIVE AND IN LIEU OF ALL OTHER WARRANTIES, GUARANTEES, AGREEMENTS, AND SIMILAR OBLIGATIONS OF TACP WITH RESPECT TO THE REPAIR OR REPLACEMENT OF ANY PARTS. IN NO EVENT SHALL TACP BE LIABLE FOR CONSEQUENTIAL OR INCIDENTAL DAMAGES (INCLUDING, BUT NOT LIMITED TO, LOST PROFITS, BUSINESS INTERRUPTION, OR MODIFICATION OR ERASURE OF RECORDED DATA CAUSED BY USE, MISUSE OR INABILITY TO USE THIS LCD TV/DVD COMBINATION).

No person, agent, distributor, dealer, or company is authorized to change, modify, or extend the terms of these warranties in any manner whatsoever. The time within which an action must be commenced to enforce any obligation of TACP arising under the warranty or under any statute or law of the United States or any state thereof is hereby limited to ninety (90) days from the date you discover, or should have discovered, the defect. This limitation does not apply to implied warranties arising under state law.

THIS WARRANTY GIVES YOU SPECIFIC LEGAL RIGHTS AND YOU MAY ALSO HAVE OTHER RIGHTS WHICH MAY VARY FROM STATE TO STATE IN THE U.S.A. SOME STATES OF THE U.S.A. DO NOT ALLOW LIMITATIONS ON HOW LONG AN IMPLIED WARRANTY LASTS, WHEN AN ACTION MAY BE BROUGHT, OR THE EXCLUSION OR LIMITATION OF INCIDENTAL OR CONSEQUENTIAL DAMAGES, SO THE ABOVE PROVISIONS MAY NOT APPLY TO YOU UNDER SUCH CIRCUMSTANCES.

63

CAUTION

THIS LCD COLOR TELEVISION EMPLOYS A LASER SYSTEM.

TO ENSURE PROPER USE OF THIS PRODUCT, PLEASE READ THIS SERVICE MANUAL CAREFULLY AND RETAIN FOR FUTURE REFERENCE. SHOULD THE UNIT REQUIRE MAINTENANCE, CONTACT AN AUTHORIZED SERVICE LOCATION-SEE SERVICE PROCEDURE.

USE OF CONTROLS, ADJUSTMENTS OR THE PERFORMANCE OF PROCEDURES OTHER THAN THOSE SPECIFIED HEREIN MAY RESULT IN HAZARDOUS RADIATION EXPOSURE.

TO PREVENT DIRECT EXPOSURE TO LASER BEAM, DO NOT TRY TO OPEN THE ENCLOSURE. VISIBLE LASER RADIATION MAY BE PRESENT WHEN THE ENCLOSURE IS OPENED. DO NOT STARE INTO BEAM.

Location of the required Marking

The rating sheet and the safety caution are on the rear of the unit.

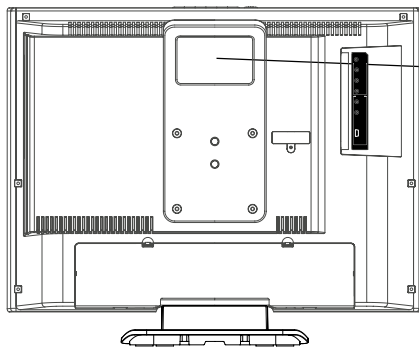

CERTIFICATION: COMPLIES WITH FDA
RADIATION PERFORMANCE STANDARDS,
21 CFR SUBCHAPTER J.

PREPARATION OF SERVICING

The laser diode used for a pickup head may be destroyed with external static electricity. Moreover, even if it is operating normally after repair, when static electricity discharge is received at the time of repair, the life of the product may be shortened. Please perform the following measure against static electricity, be careful of destruction of a laser diode at the time of repair.

- Place the unit on a workstation equipped to protect against static electricity, such as conductive mat.
- Soldering iron with ground wire or ceramic type is used.
- A worker needs to use a ground conductive wrist strap for body.

IMPORTANT SERVICE SAFETY INFORMATION

Safety precautions to be followed during servicing:

1. Parts marked with an \triangle are critical parts for safety. Replace only with the one described in the parts list.
2. Before returning the DVD product to the customer, make the appropriate leakage current check or resistance measurements to ensure that exposed parts are properly insulated from the supply circuit.

A leakage current check is recommended for this unit. Plug the AC line cord directly into a 120V 60Hz AC outlet (do not use an isolation transformer for this check). Use a leakage current tester (Fig. 1) or a metering system which complies with Underwriters Laboratories (UL 1492P). Measure for current from all exposed metal parts of the cabinet to a known earth ground: particularly, any exposed metal part having a return path to the chassis. Any current measured must not exceed 0.5mA. Any measurement not within the limits outlined above are indicative of a potential shock hazard and corrective action must be taken before returning the unit to the customer.

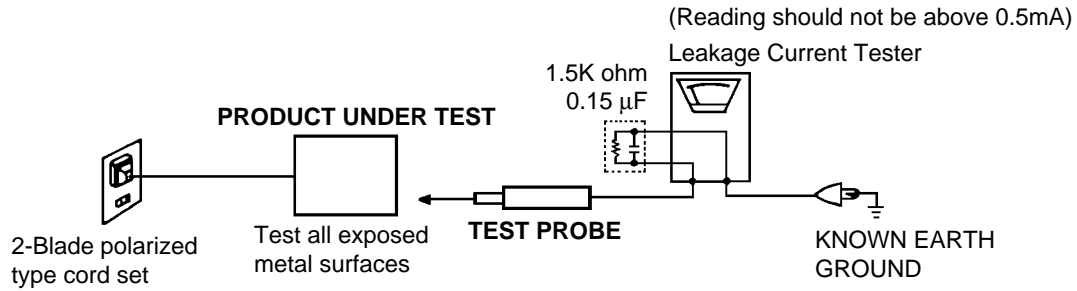

Fig. 1 AC Leakage Test

IMPORTANT SAFEGUARDS

1. READ INSTRUCTIONS

All the safety and operating instructions should be read before the unit is operated.

2. RETAIN INSTRUCTIONS

The safety and operating instructions should be retained for future reference.

3. HEED WARNINGS

All warnings on the unit and in the operating instructions should be adhered to.

4. FOLLOW INSTRUCTIONS

All operating and use instructions should be followed.

5. CLEANING

Unplug this unit from the wall outlet before cleaning. Do not use liquid cleaners or aerosol cleaners. Use a damp cloth for cleaning.

6. ATTACHMENTS

Do not use attachments not recommended by the unit's manufacturer as they may cause hazards.

7. WATER AND MOISTURE

Do not use this unit near water. For example, near a bathtub, washbowl, kitchen sink, or laundry tub, in a wet basement, or near a swimming pool.

8. ACCESSORIES

Do not place this unit on an unstable cart, stand, tripod, bracket, or table. The unit may fall, causing serious injury, and serious damage to the unit. Use only with a cart, stand, tripod, bracket, or table recommended by the manufacturer.

- 8A. An appliance and cart combination should be moved with care. Quick stops, excessive force, and uneven surfaces may cause the appliance and cart combination to overturn.

9. VENTILATION

Slots and openings in the cabinet and in the back or bottom are provided for ventilation, to ensure reliable operation of the unit, and to protect it from overheating. These openings must not be blocked or covered. The openings should never be blocked by placing the unit on a bed, sofa, rug, or other similar surface. This unit should never be placed near or over a radiator or heat source. This unit should not be placed in a built-in installation such as a bookcase or rack unless proper ventilation is provided or the manufacturer's instructions have been adhered to.

10. POWER SOURCES

This unit should be operated only from the type of power source indicated on the rating plate. If you are not sure of the type of power supply to your home, consult your appliance dealer or local power company. For units intended to operate from battery power, or other sources, refer to the operating instructions.

11. GROUNDING OR POLARIZATION

This unit is equipped with a polarized alternating-current line plug (a plug having one blade wider than the other). This plug will fit into the power outlet only one way. This is a safety feature. If you are unable to insert the plug fully into the outlet, try reversing the plug. If the plug should still fail to fit, contact your electrician to replace your obsolete outlet. Do not defeat the safety purpose of the polarized plug. If your unit is equipped with a 3-wire grounding-type plug, a plug having a third (grounding) pin, this plug will only fit into a grounding-type power outlet. This too, is a safety feature. If you are unable to insert the plug into the outlet, contact your electrician to replace your obsolete outlet. Do not defeat the safety purpose of the grounding-type plug.

12. POWER-CORD PROTECTION

Power-supply cords should be routed so that they are not likely to be walked on or pinched by items placed upon or against them, paying particular attention to cords at plugs, convenience receptacles, and the point where they exit from the appliance.

13. LIGHTNING

To protect your unit from a lightning storm, or when it is left unattended and unused for long periods of time, unplug it from the wall outlet and disconnect the antenna or cable system. This will prevent damage to the unit due to lightning and power line surges.

14. POWER LINES

An outside antenna system should not be located in the vicinity of overhead power lines or other electric light or power circuits, or where it can fall into such power lines or circuits. When installing an outside antenna system, extreme care should be taken to keep from touching such power lines or circuits, as contact with them might be fatal.

15. OVERLOADING

Do not overload wall outlets and extension cords, as this can result in a risk of fire or electric shock.

16. OBJECT AND LIQUID ENTRY

Do not push objects through any openings in this unit, as they may touch dangerous voltage points or short out parts that could result in fire or electric shock. Never spill or spray any type of liquid into the unit.

PORTABLE CART WARNING
(symbol provided by RETAC)



S3126A

17. OUTDOOR ANTENNA GROUNDING

If an outside antenna or cable system is connected to the unit, be sure the antenna or cable system is grounded so as to provide some protection against voltage surges and built-up static charges. Section 810 of the National Electrical Code, ANSI/NFPA 70, provides information with respect to proper grounding of the mast and supporting structure, grounding of the lead-in wire to an antenna discharge unit, size of grounding conductors, location of antenna discharge unit, connection to grounding electrodes, and requirements for the grounding electrode.

18. SERVICING

Do not attempt to service this unit yourself as opening or removing covers may expose you to dangerous voltage or other hazards. Refer all servicing to qualified service personnel.

19. DAMAGE REQUIRING SERVICE

Unplug this unit from the wall outlet and refer servicing to qualified service personnel under the following conditions:

- a. When the power-supply cord or plug is damaged.
- b. If liquid has been spilled, or objects have fallen into the unit.
- c. If the unit has been exposed to rain or water.
- d. If the unit does not operate normally by following the operating instructions. Adjust only those controls that are covered by the operating instructions, as an improper adjustment of other controls may result in damage and will often require extensive work by a qualified technician to restore the unit to its normal operation.
- e. If the unit has been dropped or the cabinet has been damaged.
- f. When the unit exhibits a distinct change in performance, this indicates a need for service.

20. REPLACEMENT PARTS

When replacement parts are required, be sure the service technician uses replacement parts specified by the manufacturer or those that have the same characteristics as the original parts. Unauthorized substitutions may result in fire, electric shock or other hazards.

21. SAFETY CHECK

Upon completion of any service or repairs to this unit, ask the service technician to perform safety checks to determine that the unit is in proper operating condition.

22. WALL OR CEILING MOUNTING

The product should be mounted to a wall or ceiling only as recommended by the manufacturer.

23. HEAT

The product should be situated away from heat sources such as radiators, heat registers, stoves, or other products (including amplifiers) that produce heat.

24. DISC TRAY

Keep your fingers well clear of the disc tray as it is closing. It may cause serious personal injury.

25. CONNECTING

When you connect the product to other equipment, turn off the power and unplug all of the equipment from the wall outlet. Failure to do so may cause an electric shock and serious personal injury. Read the owner's manual of the other equipment carefully and follow the instructions when making any connections.

26. SOUND VOLUME

Reduce the volume to the minimum level before you turn on the product. Otherwise, sudden high volume sound may cause hearing or speaker damage.

27. SOUND DISTORTION

Do not allow the product output distorted sound for a longtime. It may cause speaker overheating and fire.

28. HEADPHONES

When you use the headphones, keep the volume at a moderate level. If you use the headphones continuously with high volume sound, it may cause hearing damage.

29. LASER BEAM

Do not look into the opening of the disc tray or ventilation opening of the product to see the source of the laser beam. It may cause sight damage.

30. DISC

Do not use a cracked, deformed, or repaired disc. These discs are easily broken and may cause serious personal injury and product malfunction.

31. NOTE TO CATV SYSTEM INSTALLER

This reminder is provided to call the CATV system installer's attention to Article 820-40 of the NEC that provides guidelines for proper grounding and, in particular, specifies that the cable ground shall be connected to the grounding system of the building, as close to the point of cable entry as practical.

EXAMPLE OF ANTENNA GROUNDING AS PER THE NATIONAL ELECTRICAL CODE

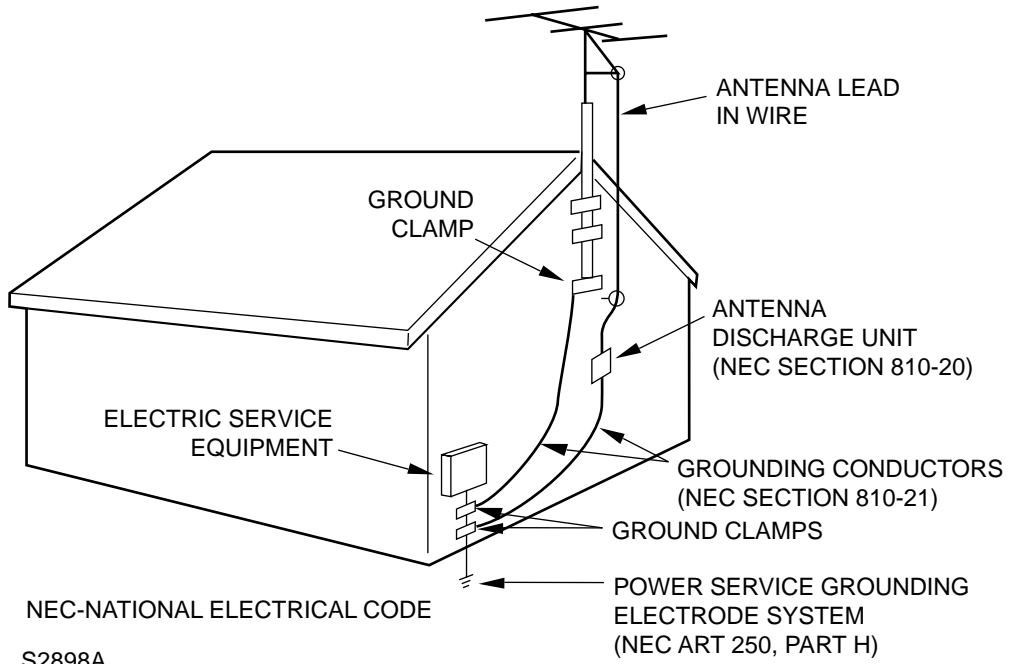

WHEN REPLACING DVD DECK

[When removing the DVD Deck]

Before removing Pick Up PCB and DVD PCB connector, the short circuit the position shown in **Fig. 1** using a soldering iron. If you remove the DVD Deck with no soldering, the Laser may be damaged.

[When installing the DVD Deck]

Remove all the soldering on the short circuit position after the connection of Pick Up PCB and DVD PCB connector.

NOTE

- Before your operation, please read "PREPARATION OF SERVICING".
- Use the Lead Free solder.
- Manual soldering conditions
 - Soldering temperature: $320 \pm 20^{\circ}\text{C}$
 - Soldering time: Within 3 seconds
 - Soldering combination: Sn-3.0Ag-0.5Cu
- When Soldering/Removing of solder, use the draw in equipment over the Pick Up Unit to keep the Flux smoke away from it.

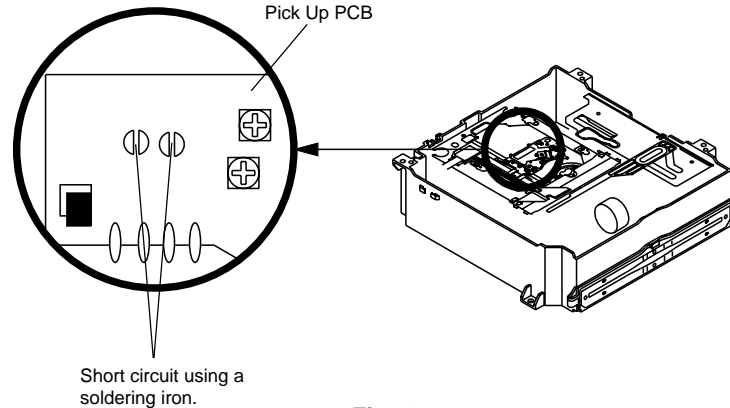

Fig. 1

DISC REMOVAL METHOD AT NO POWER SUPPLY

1. Remove the Back Cabinet. (Refer to item 1 of the DISASSEMBLY INSTRUCTIONS.)
2. Slide the Rack Loading toward the arrow direction by hand to release the lock. (Refer to Fig. 1)
3. Take out the Disc from the DVD Deck. Be careful not to scratch on the Disc.

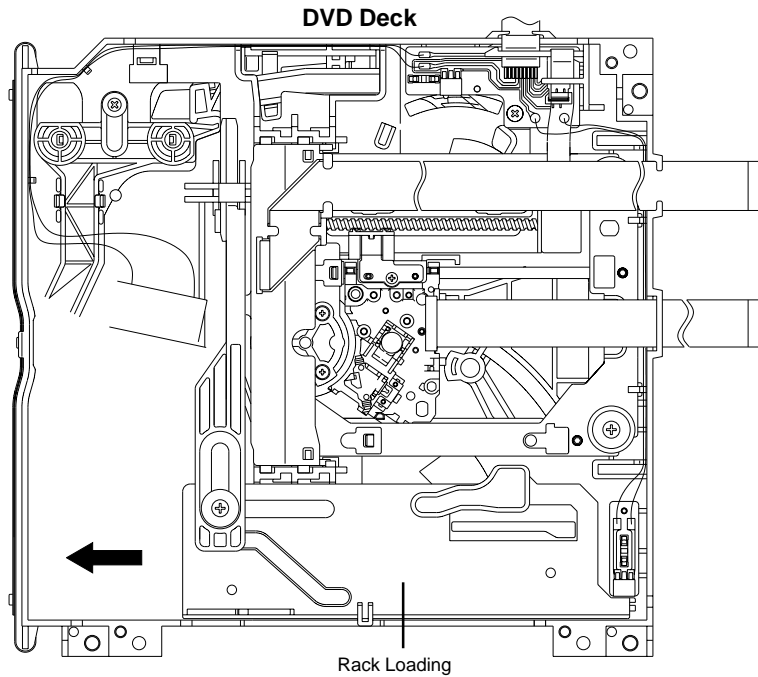

Fig. 1

PARENTAL CONTROL - RATING LEVEL 4 DIGIT PASSWORD CANCELLATION

If the stored 4 digit password in the Rating Level menu needs to be cancelled, please follow the steps below.

1. Turn Unit ON.
2. Set the DVD to the Stop Mode.
3. Check that 'No disc' is displayed on the screen.
4. Press and hold the 'STOP' button on the front panel.
5. Simultaneously press and hold the '7' key on the remote control unit.
6. Hold both keys for more than 2 seconds.
7. The On Screen Display message 'PASSWORD CLEAR' will appear.
8. The 4 digit password has now been cleared.

TRAY LOCK

The disk cannot be taken out by setting the Tray Lock, please follow the steps below.

1. Turn Unit ON.
2. Set the DVD to the Stop Mode.
3. Press and hold the 'STOP' key on the front panel.
4. Simultaneously press and hold the '9' key on the remote control unit.
5. Hold both keys for more than 2 seconds.
6. Press the OPEN/CLOSE key on the front panel to check the Tray Lock setting.

NOTE: No indications on the screen when the Tray Lock is setting.

To unlock the Tray Lock, please follow the steps below.

1. Turn Unit ON.
2. Set the DVD to the Stop Mode.
3. Press and hold the 'STOP' key on the front panel.
4. Simultaneously press and hold the '9' key on the remote control unit.
5. Hold both keys for more than 2 seconds.
6. The Tray Lock has now been cleared.

NOTE: No indications on the screen when the Tray Lock is setting.

It is likely to be going to be changed to the following steps without a previous notice in the future.

If the above is not effective measures, please follow the steps below.

The disk cannot be taken out by setting the Tray Lock, please follow the steps below.

1. Turn Unit ON.
2. Set the DVD to the Stop Mode.
3. Press it in order of 'SETUP', 'SUBTITLE', '3', 'AUDIO SELECT' and '0' key of a remote control unit.
4. The On Screen Display message '🔒' will appear.
5. The Tray Lock has now been set up.

NOTE: No indications on the screen when the Tray Lock is setting.

To unlock the Tray Lock, please follow the steps below.

1. Turn Unit ON.
2. Set the DVD to the Stop Mode.
3. Press it in order of 'SETUP', 'SUBTITLE', '3', 'AUDIO SELECT' and '0' key of a remote control unit.
4. The On Screen Display message '🔒' will appear.
5. The Tray Lock has now been cleared.

NOTE: No indications on the screen when the Tray Lock is setting.

ABOUT LEAD FREE SOLDER (PbF)

Distinction of PbF PCB:

PCBs (manufactured) using lead free solder will have a PbF printing on the PCB.
(Please refer to figures.)

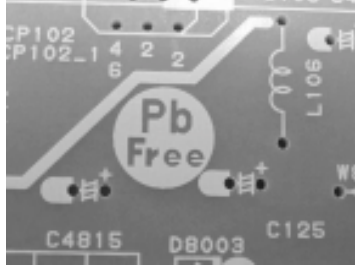

Caution:

- Pb free solder has a higher melting point than standard solder;
Typically the melting point is 50°F~70°F(30°C~40°C) higher.
Please use a soldering iron with temperature control and adjust it to 650°F ± 20°F (350°C ± 10°C).
In case of using high temperature soldering iron, please be careful not to heat too long.
- Pb free solder will tend to splash when heated too high (about 1100°F/ 600°C).
- All products with the printed circuit board with PbF printing must be serviced with lead free solder.
When soldering or unsoldering, completely remove all of the solder from the pins or solder area,
and be sure to heat the soldering points with the lead free solder until it melts sufficiently.

Recommendations

Recommended lead free solder composition is Sn-3.0Ag-0.5Cu.

TABLE OF CONTENTS

• OWNER'S MANUAL

CAUTION	A1-1
IMPORTANT SERVICE SAFETY INFORMATION	A1-2
IMPORTANT SAFEGUARDS	A1-3~A1-5
WHEN REPLACING DVD DECK	A1-6
DISC REMOVAL METHOD AT NO POWER SUPPLY	A1-7
PARENTAL CONTROL - RATING LEVEL	A1-7
TRAY LOCK	A1-8
ABOUT LEAD FREE SOLDER (PbF)	A1-9
TABLE OF CONTENTS	A2-1
GENERAL SPECIFICATIONS	A3-1~A3-8
DISASSEMBLY INSTRUCTIONS	
1.REMOVAL OF MECHANICAL PARTS AND P.C. BOARDS	B1-1~B1-3
2.REMOVAL OF DVD DECK PARTS	B2-1~B2-3
3.REMOVAL AND INSTALLATION OF FLAT PACKAGE IC	B3-1, B3-2
SERVICE MODE LIST	C-1
CONFIRMATION OF HOURS USED	C-1
SERVICING FIXTURES AND TOOLS	C-2
RE-WRITE FOR DVD FIRMWARE	C-2
CONFIRMATION OF CHECK SUM	C-3
WHEN REPLACING EEPROM (MEMORY) IC	C-3~C-5
ELECTRICAL ADJUSTMENTS	D-1~D-4
TROUBLESHOOTING GUIDE	E-1~E-11
BLOCK DIAGRAMS	
DVD	F-1, F-2
SCALER/LVDS/MICON/ADC/JACK/AV_SW/REGULATOR	F-3, F-4
AV_SW/TUNER/JACK/STEREO/SOUND AMP	F-5, F-6
POWER	F-7, F-8
INTERFACE	F-9, F-10
MICON2	F-11, F-12
AC ADAPTER	F-13, F-14
PRINTED CIRCUIT BOARDS	
SCALER	G-1, G-2
AV/OPERATION1/REMOCON	G-3~G-6
DVD/OPERATION2	G-7, G-8
HD-MI/AC ADAPTER START SW/END SW	G-9, G-10
SCHEMATIC DIAGRAMS	
AV SWITCH1	H-1, H-2
TUNER/JACK	H-3, H-4
STEREO/SOUND	H-5, H-6
POWER	H-7, H-8
OPERATION1/REMOCON	H-9, H-10
MICON1	H-11, H-12
SCALER	H-13, H-14
ADC	H-15, H-16
LVDS	H-17, H-18
JACK	H-19, H-20
AV SWITCH2	H-21, H-22
REGULATOR1	H-23, H-24
MPEG/MICON/DSP	H-25, H-26
MEMORY2	H-27, H-28
RF AMP	H-29, H-30
AUDIO/VIDEO	H-31, H-32
MOTOR DRIVE	H-33, H-34
REGULATOR2	H-35, H-36
OPERATION2	H-37, H-38
INTERFACE	H-39, H-40
MICON2	H-41, H-42
AC ADAPTER	H-43, H-44
START SE/END SW	H-45, H-46
INTERCONNECTION DIAGRAM	H-47, H-48
WAVEFORMS	I-1~I-4
MECHANICAL EXPLODED VIEWS	J1-1~J1-4
DVD DECK EXPLODED VIEWS	J2-1, J2-2
MECHANICAL REPLACEMENT PARTS LIST	K1-1, K1-2
DVD DECK REPLACEMENT PARTS LIST	K2-1
ELECTRICAL REPLACEMENT PARTS LIST	K3-1~K3-24

GENERAL SPECIFICATIONS

G-1	TV System	LCD	LCD Size / Visual Size	20.04 inch / 508.9mmV	
			LCD Type	Color TFT LCD	
			Number of Pixels	1366(H) x 768(V)	
			View Range	89/89 degree	
				Left/Right Up/Down	89/89 degree
		Color System		NTSC	
		Speaker		2 Speaker	
			Position	Front	
			Size	1.8 x 3.9 inch	
			Impedance	16 ohm	
		Sound Output	Max	2.5W + 2.5W	
			10%(Typical)	---	
G-2	DVD System	Color System		NTSC	
		Disc		DVD, CD-DA, CD-R/RW, Video CD DVD-R/RW (Video Format Only)	
		Disc Diameter		120 mm , 80 mm(with Disc Adapter)	
		Drive		DSM-1	
		Search speed	Fwd		4 step
				Actual	2-45 times (DVD, VIDEO CD) 4-40 times (CD)
			Rev		4 step
				Actual	2-45 times (DVD, VIDEO CD) 4-40 times (CD)
			Slow speed	Fwd	1/7 -1/2 times
				Actual	--
		Rev	1/7 -1/2 times		
		Actual	--		
G-3	Tuning System	Broadcasting System		US System M	
		Tuner and	System	1Tuner	
		Receive CH	Destination	US (W/CABLE)	
			CH Coverage	2~69, 4A, A-5~A-1, A~I, J~W, W+1~W+84	
		Intermediate	Picture(FP)	45.75MHz	
		Frequency	Sound(FS)	41.25MHz	
			FP-FS	4.50MHz	
			Preset CH	No	
	Stereo/Dual TV Sound		US-Stereo		
	Tuner Sound Muting		Yes		
G-4	Signal	Video Signal	Input Level	1 V p-p/75 ohm	
			Output Level	--	
			S/N Ratio (Weighted)	--	
			Horizontal Resolution at DVD Mode	--	
				--	
			RGB Signal	Output Level	--
			Audio Signal	Input Level	-8.0dBm/50k ohm
				Output Level at DVD	--
				at TV	--
				Digital Output Level	0.5 V p-p/75 ohm
				S/N Ratio at DVD (Weighted)	--
				Harmonic Distortion	--
		Frequency Response :	at DVD		
			at Video CD		
			at SVCD		
			at CD		
G-5	Power	Power Source	AC	120V, 60Hz	
			DC	--	
		Power Consumption		at AC	100W at 120V 60Hz
				at DC	--
			Stand by (at AC)		1W at 120V 60Hz
			Energy Star		Yes
			Per Year		-- kWh/Year
	Protector	Power Fuse	Yes		
		Safety Circuit	Yes		
		IC Protector(Micro Fuse)	Yes		
G-6	Regulation	Safety		UL/CSA	
		Radiation		FCC/IC	
		Laser		DHHS	
G-7	Temperature	Operation		+5oC ~ +40oC	
		Storage		-20oC ~ +60oC	
G-8	Operating Humidity			Less than 80% RH	

GENERAL SPECIFICATIONS

G-9	On Screen Display	Menu (TV)	Menu Type	Yes
		Picture	Icon	Yes
		Mode(Picture preference)		Yes
		Brightness		Yes
		Contrast		Yes
		Color		Yes
		Tint		Yes
		Sharpness		Yes
		Cable Clear		Yes
		Color Temperature		Yes
		Reset		Yes
		Audio		Yes
		MTS		Yes
		Bass		Yes
		Treble		Yes
		Balance		Yes
		Stable Sound		Yes
		Speakers On/Off		No
		Dolby Virtual		No
		WOW SRS 3D		Yes
		WOW Focus		Yes
		WOW Tru Bass		Yes
		HDMI		Yes
		Reset		Yes
		Setup		Yes
		Language		Yes
		Clock Set		Yes
		TV/CABLE		Yes
		CH Program		Yes
		Add/ Erase		Yes
		Closed Caption		Yes
		Picture Size		Yes
		Picture Scroll		No
		Cinema Mode		Yes
		Aspect		Yes
		Back Lighting		Yes
		Option		Yes
		On Timer		Yes
		Favorite CH		Yes
		CH Label		Yes
		VIDEO Label		Yes
		Locks		Yes
V-Chip Set		Yes		
CH Lock		Yes		
Video Lock		Yes		
Game Timer		Yes		
Panel Lock		Yes		
New Password		Yes		
PC Monitor Picture Menu		Yes		
Brightness		Yes		
Contrast		Yes		
Hor Position		Yes		
Ver Position		Yes		
Phase		Yes		
Clock		Yes		
Auto Adjust		No		
Red		Yes		
Green		Yes		
Blue		Yes		
WXGA INPUT		Yes		
Reset		Yes		
PC Monitor Audio Menu		Yes		
Bass		Yes		
Treble		Yes		
Balance		Yes		
Stable Sound		Yes		
WOW SRS 3D		Yes		
WOW Focus		Yes		
WOW Tru Bass		Yes		
Reset		Yes		

GENERAL SPECIFICATIONS

	Control Level	Yes
	Volume	Yes
	Brightness	Yes
	Contrast	Yes
	Color	Yes
	Tint	Yes
	Sharpness	Yes
	Bass	Yes
	Treble	Yes
	Balance	Yes
	Picture Scroll	No
	Back Lighting	Yes
	H Position	Yes
	V Position	Yes
	Phase	Yes
	Clock	Yes
	Red	Yes
	Green	Yes
	Blue	Yes
	Stereo, SAP, Mono	Yes
	CH / AV(Line) / DVD / PC	Yes
	Color Stream HD (Component)	Yes
	HDMI	Yes
	Channel (TV/Cable)	Yes
	CH Label	Yes
	Video Label	Yes
	Clock	Yes
	Game Timer	Yes
	Panel Lock	Yes
	On Timer	Yes
	Sleep Timer	Yes
	Reset	Yes
	Sound Mute	Yes
	V-chip Rating	Yes
	NOT AVAILABLE	Yes
	Picture Size	Yes

GENERAL SPECIFICATIONS

G-10	On Screen Display	Menu (DVD)		Yes
		Menu Type		Character
		Language		Yes
		Menu		Yes
		Subtitle		Yes
		Audio		Yes
		Picture		Yes
		TV Screen Size(4:3, 16:9)		Yes
		OSD Display On/Off		Yes
		JPEG Interval		Yes
		Select Files		Yes
		Sound		Yes
		DRC (Dynamic Range Control)		Yes
		dts Decode		No
		Output(5.1ch/ 2ch)		No
		Surround On/Off		No
		Center On/Off		No
		Sub Woofer On/Off		No
		Parental		Yes
		Password Lock/ Un Lock		Yes
		Rating Level		Yes
		Other		Yes
		OSD Language(Set up Language)		Yes
		Output(RGB/Composite)		No
		Eject		Yes
		No disc		Yes
		Reading		Yes
		Play		Yes
		Still/Pause		Yes
		Stop		Yes
		Prohibit Mark		Yes
		Step		Yes
		Skip(>>)		Yes
		Skip(<<)		Yes
		Random		Yes (CD, VIDEO CD, MP3, WMA, JPEG)
		Repeat		Yes
		Slow+		Yes
		Slow-		Yes
		Search+		Yes
		Search-		Yes
		Jump		Yes
		Resume		Yes
		Title No.		Yes
		Chapter No.		Yes
		Track No.		Yes
		Time		Yes
		Subtitle No.		Yes
Angle No.		Yes		
Vocal On/Off		Yes		
Audio No.		Yes		
Audio L/R		Yes (Video CD)		
Zoom		Yes		
Marker No.		Yes		
Program Play Back		Yes (CD, VIDEO CD, MP3, WMA, JPEG)		
Surround On/Off		No		
Screen Saver		No		
MP3/WMA/JPEG		Folder Name		
		File Name		
		File No		
		Time		
		Track No		
		Yes		
G-11	OSD Language	(TV) (DVD)	English, French, Spanish English, French, Spanish	
G-12	Clock and Timer	Sleep Timer	Max Time	120 Min
			Step	<u> 10 </u> Min
		On Timer	Program	<u> Yes </u>
		Wake Up Timer		<u> No </u>
	Timer Back-up (at Power Off Mode)	more than	--	Min Sec

GENERAL SPECIFICATIONS

G-13	Remote Control	Unit	RC-LT	
		Glow in Dark Remocon	Yes	
		Remocon Format	TOSHIBA	
		Format	TOSHIBA	
		Custom Code	40-BF h ,44-BB h ,45-BA h ,45-BC h	
		Power Source	Voltage(D.C) UM size x pcs	3V UM-4 x 2 pcs
		Total Keys		49 Keys
		Keys	Power	Yes
			EJECT	Yes
			SLEEP	Yes
			TV/DVD	Yes
			1	Yes
			2	Yes
			3	Yes
			4	Yes
			5	Yes
			6	Yes
			7	Yes
			8	Yes
			9	Yes
			0	Yes
			100 / JUMP	Yes
			DISPLAY	Yes
			SUBTITLE	Yes
			AUDIO SELECT	Yes
			INPUT / ZOOM	Yes
			MUTE	Yes
			CH +	Yes
			CH -	Yes
			VOL +	Yes
			VOL -	Yes
			PLAY MODE	Yes
			DVD MENU	Yes
			UP	Yes
			LEFT / FAV -	Yes
			ENTER	Yes
			RIGHT / FAV +	Yes
			DOWN	Yes
			TV MENU/SETUP	Yes
			EXIT / CANCEL	Yes
			GAME	Yes
			PIC SIZE	Yes
			PAUSE	Yes
			PLAY	Yes
			STOP	Yes
			CH RTN /<SKIP	Yes
			SEARCH -	Yes
			SEARCH +	Yes
			Closed Caption / SKIP>	Yes
< SLOW	Yes			
ANGLE	Yes			
Marker	Yes			
SLOW >	Yes			
TOP MENU	Yes			
RETURN	Yes			
REPEAT A-B	Yes			

GENERAL SPECIFICATIONS

G-14	Features (TV)	Auto Shut Off	Yes
		Auto Search	No
		Comb Filter	Yes 3 -D
		Game Position	Yes
		Power On Memory	Yes
		Variable Audio Out	No
		Mode (Picture Preference)	Yes
		Color Temperature Control	Yes
		Cable Clear	Yes
		SAP	Yes
		Stable Sound	Yes
		Virtual Dolby	No
		SRS WOW(SRS 3D/Focus/Tru Bass)	Yes
		CABLE	Yes
		CH Program (Auto CH Memory)	Yes
		Closed Caption	Yes
		Picture Size	Yes
		Picture Scroll	No
		Cinema Mode	Yes
		Aspect	Yes
		On Timer	Yes
		Sleep Timer	Yes
		Favorite CH	Yes
		CH Label	Yes
		VIDEO Label	Yes
		V-Chip	Yes
		Type	USA Type
		CH Lock	Yes
		Video Lock	Yes
		Game Timer(Max Time:120Min)	Yes
		Panel Lock	Yes
		Direct Input Selection	Yes
PC Monitor Input	Yes		
Available Scan Rates (Component/HDMI)	480i/480p/720p/1080i		
Auto Setup(Language/CH Program)	Yes		
Freeze frame	No		
Features (DVD)	Tray Lock	Yes	
	Video CD Playback	Yes	
	SVCD Playback	No	
	Overlay Graphics And Text	No	
	Command List	No	
	Entry Point Jump	No	
	MP3 Playback	Yes	
	JPEG	Yes	
	WMA	Yes	
	Digital Out (Dolby Digital)	Yes	
	(MPEG)	Yes	
	(PCM)	Yes	
	(DTS)	Yes	
	Down Mix Out (Dolby Digital)	Yes	
	(DTS)	No	
Screen Saver	No		
Audio DAC	192kHz / 24bit		

GENERAL SPECIFICATIONS

G-15	Accessories	Owner's Manual	Language w/Guarantee Card	English / French Yes	
		Remote Control Unit		Yes	
		Rod Antenna		No	
			Poles	--	
			Terminal	--	
		Loop Antenna		No	
			Terminal	--	
		U/V Mixer		No	
		DC Car Cord (Center+)		No	
		Guarantee Card		No	
		Warning Sheet		No	
		Circuit Diagram		No	
		Antenna Change Plug		No	
		Service Facility List		No	
		Important Safeguard		No	
		Dew/AHC Caution Sheet		No	
		Quick Set-up Sheet		No	
		Battery		Yes	
			UM size x pcs	UM-4 x 2 pcs	
			OEM Brand	No	
		AC Adapter		Yes	
		AC Cord (for AC Adapter)		Yes	
		AV Cord (2Pin-1Pin)		No	
		Registration Card (NDL Card)		Yes	
		300ohm to 75ohm Antenna Adapter		No	
		Sheet Information (Return)		Yes	
Sheet Information (HDMI)		No			
Screw for wall hanging		No			
G-16	Interface	Switch	Top	Power (Tact)	Yes
			Channel Up/Menu Up	Yes	
			Channel Down/Menu Down	Yes	
			Volume Up/Menu >	Yes	
			Volume Down/Menu <	Yes	
			Menu	Yes	
			Play	Yes	
			Eject	Yes	
			Skip+, Search+	Yes	
			Skip-, Search-	Yes	
			Still/Pause	No	
			Stop	Yes	
			Main Power SW	No	
			Input Select	Yes	
			Indicator	Power	Yes (Red)
				Stand-by	No
		On Timer		No	
		Terminals	Rear	Video Input 1	RCA x 1
				Audio Input 1	RCA x 2(Stereo)
				S - Input 1	Yes
				Video Output	No
				Audio Output	No
				Component Input(w/ Analog Audio L/R)	RCA x 5
				HDMI Input(w/ Analog Audio L/R)	HDMI x 1(RCA x 2)
				PC Monitor Input(w/ Analog Audio L/R)	No
			Digital Audio Output	Coaxial (DVD Only)	
			DC Jack	Yes	
			VHF/UHF Antenna Input	F Type	
			AC Outlet	No	
			Side	Video Input 2	RCA x 1
				Audio Input 2	RCA x 2(Stereo)
				PC Monitor Input(w/ Analog Audio L/R)	Dsub15pin x 1(RCA x 2)
Other Terminal	Headphone				
G-17	Set Size	Approx. W x D x H (mm)	554 x 220 x 448		
		w/o Handle, Stand Approx. W x D x H (mm)	554 x 110 x 403		
G-18	Weight	Net (Approx.)	9.0kg (19.8 lbs)		
		Net w/o Handle, Stand (Approx.)	7.5kg (16.5 lbs)		
		Gross (Approx.)	12.0kg (26.5 lbs)		

GENERAL SPECIFICATIONS

G-19	Carton	Master Carton	No	
		Content	--- Sets	
		Material	--- / ---	
		Dimensions W x D x H(mm)	---	
		Description of Origin	---	
		Gift Box	Material	Double/ White
		W/Color Photo Label	No	
		W/Handle	No	
		Dimensions W x D x H(mm)	654 x 338 x 565	
		Description of Origin	No(Assembled In Thailand)	
		Drop Test	1 Corner / 3 Edges / 6 Surfaces	
Height (cm)	62			
Container Stuffing (40' container)	492 Sets			
G-20	Material	Cabinet	Front	PS 94V0 DECABROM
			Rear	PS 94V0 DECABROM
		PCB	Non-Halogen Demand	No
			Eyelet Demand	No
G-21	Environment	Environmental standard requirement (by buyer)	Green PROCUREMENT of TOSHIBA	
		Pb-Free	Phase 3 (Phase 3A)	
G-22	AC Power Adapter		Provided Accessories	
		Power Requirement	AC 120V 60Hz	
		Power Consumption	at AC 100 W	
		DC Output	DC Jack : DC24V 3.4A	
		Dimension	Approx. W x D x H (mm) 200 x 90 x 60	
		Weight	Approx. 1.5kg (3.3 lbs)	

DISASSEMBLY INSTRUCTIONS

1. REMOVAL OF MECHANICAL PARTS AND P.C. BOARDS

1-1: HANDLE/BACK COVER ASS'Y (Refer to Fig. 1-1)

1. Remove the 4 screws ①.
2. Remove the Handle in the direction of arrow (A).
3. Unlock the 6 supports ②.
4. Remove the Back Cover Ass'y in the direction of arrow (B).

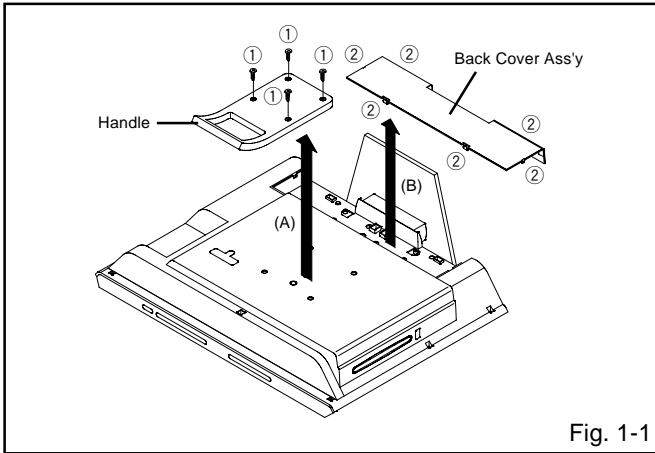

Fig. 1-1

1-2: HINGE ASS'Y (Refer to Fig. 1-2)

1. Remove the 4 screws ①.
2. Remove the Stand in the direction of arrow (A).
3. Remove the 8 screws ②.
4. Remove the Stand Angle in the direction of arrow (B).
5. Remove the 4 screws ③.
6. Remove the Hinge Ass'y in the direction of arrow (C).

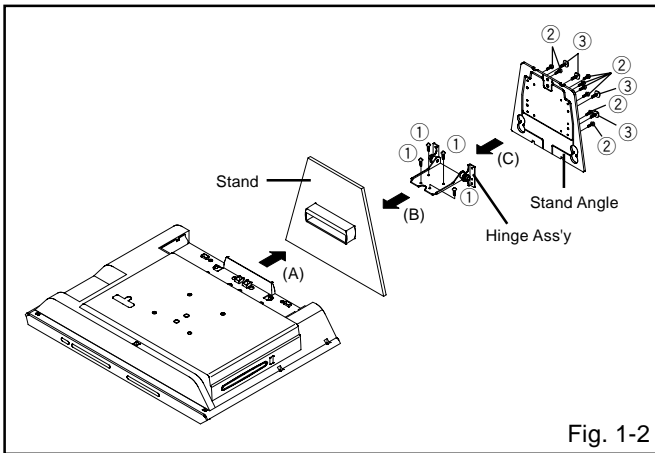

Fig. 1-2

1-3: BACK CABINET (Refer to Fig. 1-3)

1. Remove the 11 screws ①.
2. Remove the screw ②.
3. Remove the Back Cabinet in the direction of arrow.

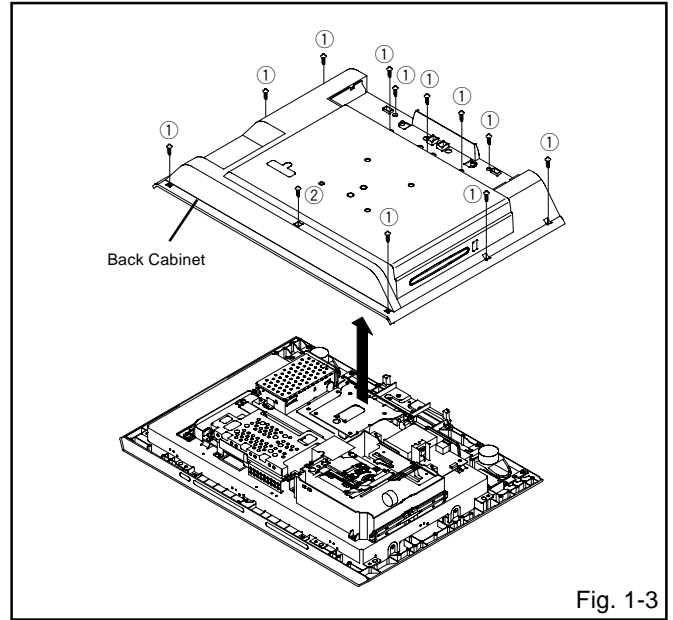

Fig. 1-3

1-4: HANDLE ANGLE (Refer to Fig. 1-4)

1. Remove the screw ①.
2. Remove the 2 screws ②.
3. Remove the Handle Angle in the direction of arrow.

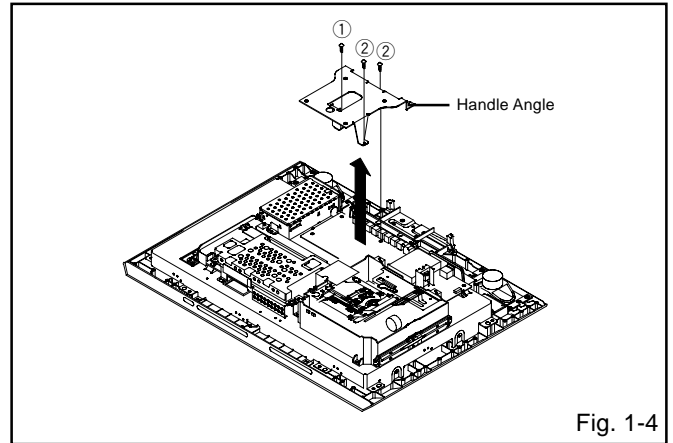

Fig. 1-4

DISASSEMBLY INSTRUCTIONS

1-5: DVD DECK (Refer to Fig. 1-5)

1. Make the short circuit on the position as shown Fig. 1-5 using a soldering. If you remove the DVD Deck with no soldering, the Laser may be damaged.
2. Disconnect the following connectors: **(CP2301, CP2302 and CP2601)**.
3. Remove the 4 screws ①.
4. Remove the DVD Deck in the direction of arrow.

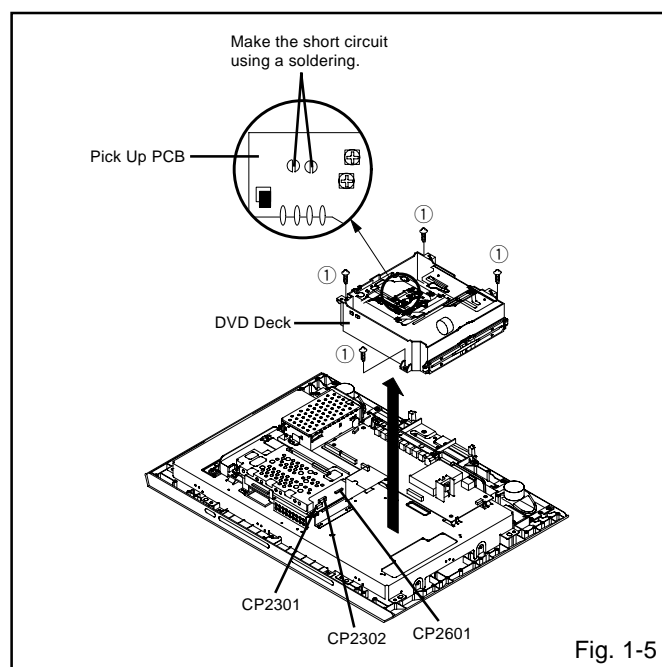

Fig. 1-5

NOTE

1. Use the Pb Free solder and the exclusive soldering iron.
2. Manual soldering conditions
 - Soldering temperature: $320 \pm 20^{\circ}\text{C}$
 - Soldering time: Within 3 seconds
 - Soldering combination: 45/55 Sn/Pb
3. When Soldering/Removing of solder, use the drawing equipment over the Pick Up Unit to prevent the Flux smoke from it.
4. When the installation of the DVD Deck, remove all the soldering on the short circuit position after the connection of Pick Up PCB and DVD PCB connector.

1-6: DVD PCB (Refer to Fig. 1-6)

1. Disconnect the following connectors: **(CP3802 and CP4303)**.
2. Remove the 4 screws ①.
3. Remove the Shield DVD, DVD PCB and Shield FFC in the direction of arrow (A).
4. Remove the 4 screws ②.
5. Remove the Angle PCB in the direction of arrow (B).

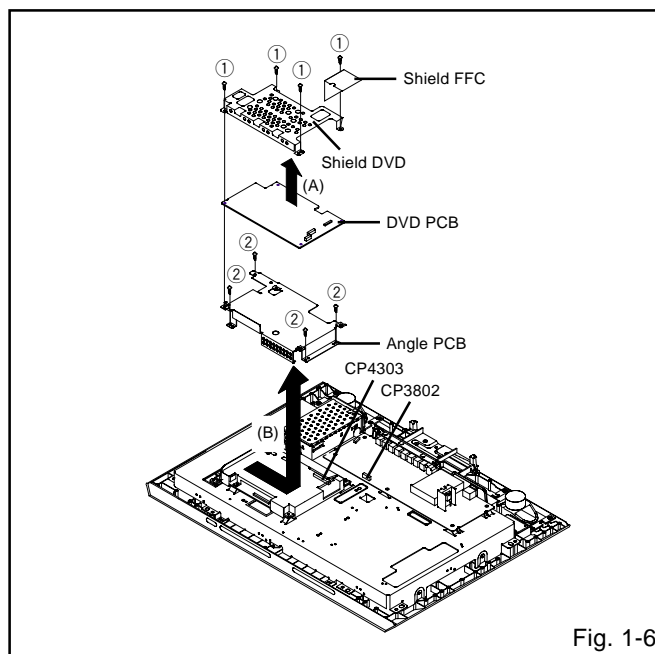

Fig. 1-6

1-7: HD-MI PCB (Refer to Fig. 1-7)

1. Disconnect the following connector: **(CP4301)**.
2. Remove the screw ①.
3. Remove the 2 screws ②.
4. Remove the Jack Plate in the direction of arrow (A).
5. Remove the 3 screws ③.
6. Remove the HD-MI PCB in the direction of arrow (B).

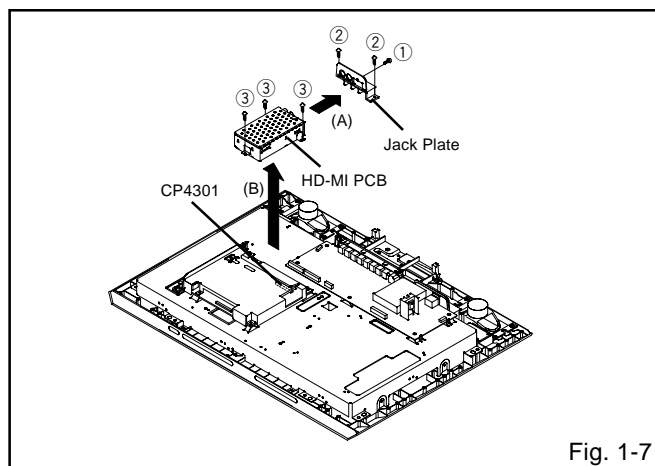

Fig. 1-7

1-8: SCALER PCB (Refer to Fig. 1-8)

1. Disconnect the following connectors: **(CP801, CP802, CP2200 and CP3201)**.
2. Remove the 2 screws ①.
3. Remove the Side Jack Plate in the direction of arrow (A).
4. Remove the 4 screws ②.
5. Remove the Shield LCD in the direction of arrow (B).
6. Remove the Scaler PCB in the direction of arrow (C).

DISASSEMBLY INSTRUCTIONS

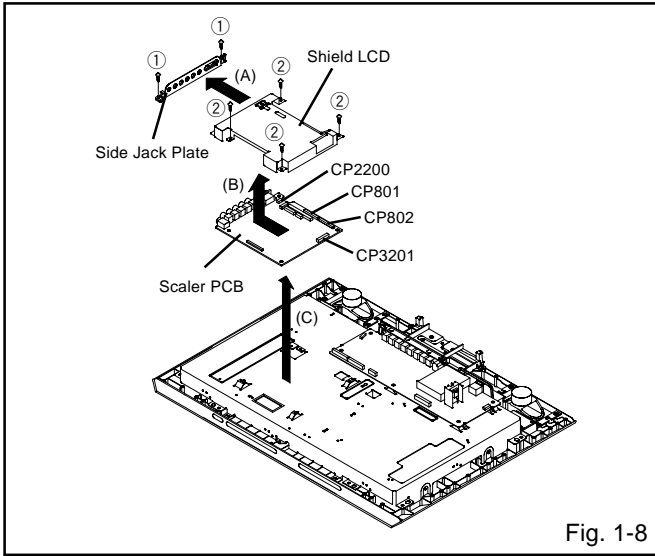

Fig. 1-8

1-9: AV PCB (Refer to Fig. 1-9)

1. Disconnect the following connectors: **(CP301, CP3801 and CP5002)**.
2. Remove the screw ①.
3. Remove the 2 screws ②.
4. Remove the Jack Plate 1 and Jack Shield 1 in the direction of arrow (A).
5. Remove the 2 screws ③.
6. Remove the 2 screws ④.
7. Remove the Jack Plate 2 and Jack Shield 2 in the direction of arrow (B).
8. Remove the 5 screws ⑤.
9. Remove the AV PCB in the direction of arrow (C).

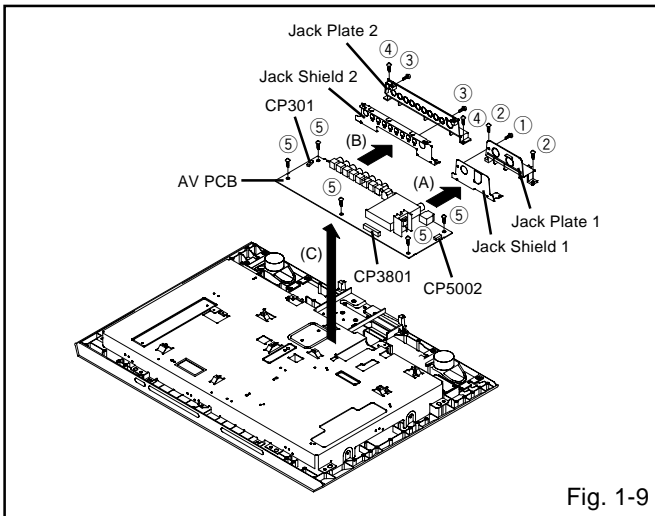

Fig. 1-9

1-10: REMOCON PCB (Refer to Fig. 1-10)

1. Remove the 2 screws ①.
2. Remove the Remocon PCB in the direction of arrow.

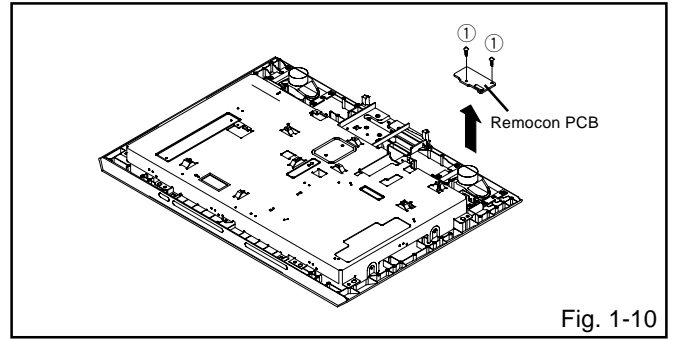

Fig. 1-10

1-11: LCD COVER/LCD PANEL/OPERATION 1/2 PCB (Refer to Fig. 1-11)

1. Remove the 3 screws ①.
2. Remove the 2 screws ②.
3. Remove the 2 screws ③.
4. Remove the Angle Hinge in the direction of arrow (A).
5. Remove the screw ④.
6. Remove the 8 screws ⑤.
7. Remove the LCD Cover in the direction of arrow (B).
8. Disconnect the following connector: **(CP2251)**.
9. Remove the 4 screws ⑥.
10. Remove the Operation 1/2 PCB in the direction of arrow (C).
11. Remove the 4 screws ⑦.
12. Remove the LCD Panel in the direction of arrow (D).

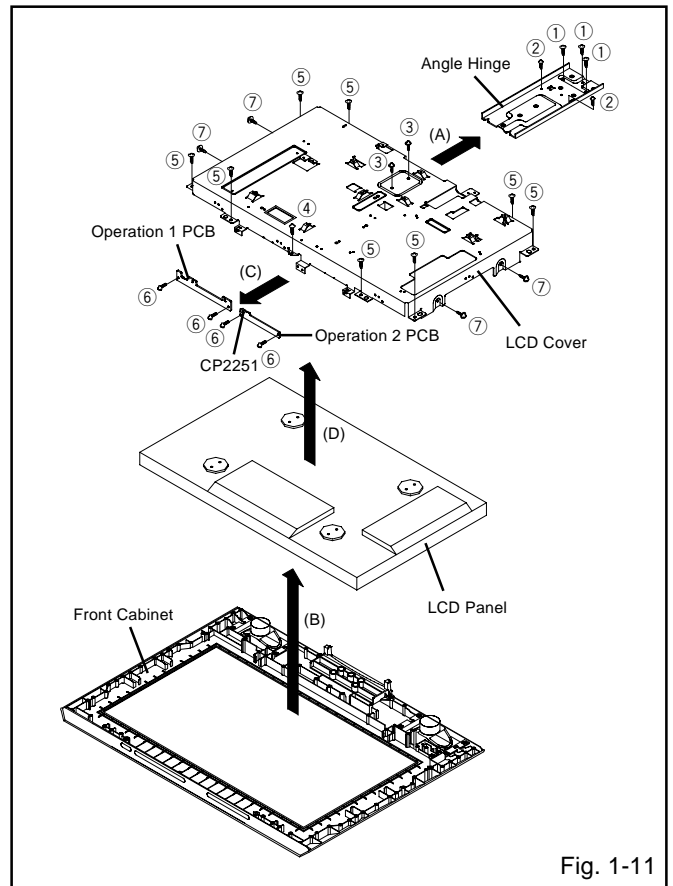

Fig. 1-11

DISASSEMBLY INSTRUCTIONS

2. REMOVAL OF DVD DECK PARTS

2-1: LOADING MOTOR ASS'Y/START SW PCB ASS'Y/ END SW PCB ASS'Y (Refer to Fig. 2-1-A)

1. Remove the 3 screws ①.
2. Remove the Loading Motor Ass'y.
3. Remove the 2 screws ②.
4. Remove the Motor and Loading Worm.
5. Disconnect the following connector: (CP2).
6. Remove the screw ③.
7. Unlock the 2 supports ④ and remove the Start SW PCB Ass'y.
8. Unlock the 2 supports ⑤ and remove the End SW PCB Ass'y.

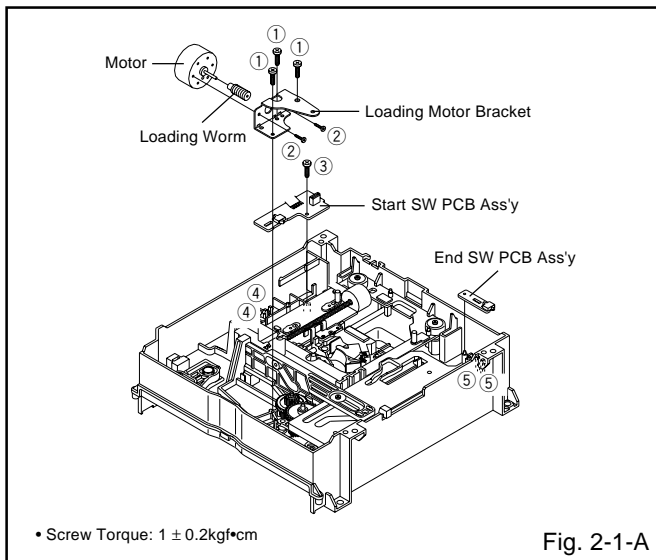

NOTE

1. In case of the Loading Worm installation, check if the value of the Fig. 2-1-B is correct.
2. When installing the wire, install it correctly as Fig. 2-1-B.

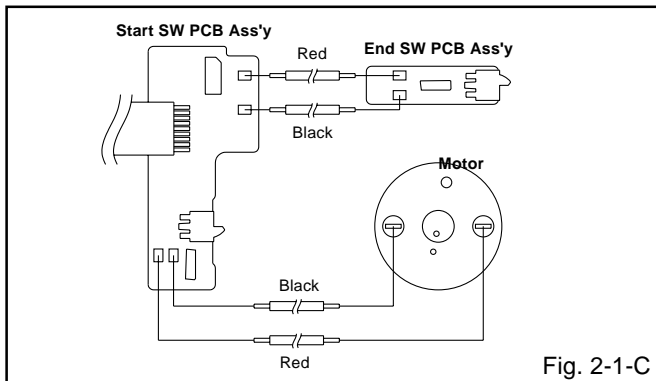
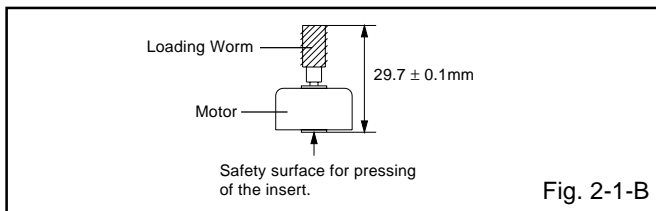

2-2: TRAVERSE UNIT ROD/TRAVERSE UNIT HOLDER/ CD DECK/INSULATOR (Refer to Fig. 2-2)

1. Remove the screw ①.
2. Remove the Traverse Unit Rod.
3. Remove the 2 screws ③.
4. Unlock the 2 supports ④ and remove the CD Deck Block.
5. Remove the 2 screws ⑤.
6. Unlock the 2 supports ⑥ and remove the Traverse Unit Holder.
7. Remove the 4 Insulators.

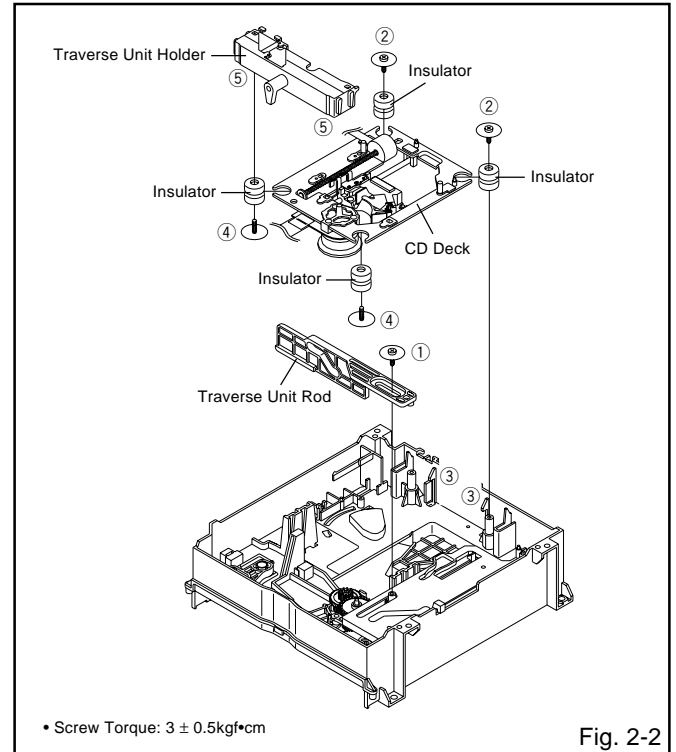

2-3: MOUTH ASS'Y (Refer to Fig. 2-3)

1. Remove the 2 screws ①.
2. Remove the Mouth Ass'y.

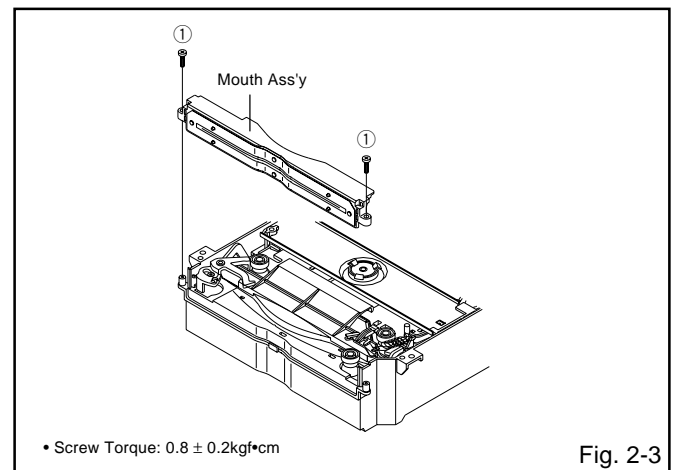

DISASSEMBLY INSTRUCTIONS

2-4: DISC L LEVER/DISC STOPPER/LOCKER STOPPER/ROLLER GEAR (Refer to Fig. 2-4-A)

1. Remove the screw ①.
2. Remove the Disc L Lever and Disc L Lever Spring.
3. Remove the Stopper Spring.
4. Unlock the support ② and remove the Locker Stopper.
5. Unlock the support ③ and remove the Disc Stopper.
6. Remove the Upper Roller, Roller Rubber and Roller Gear.

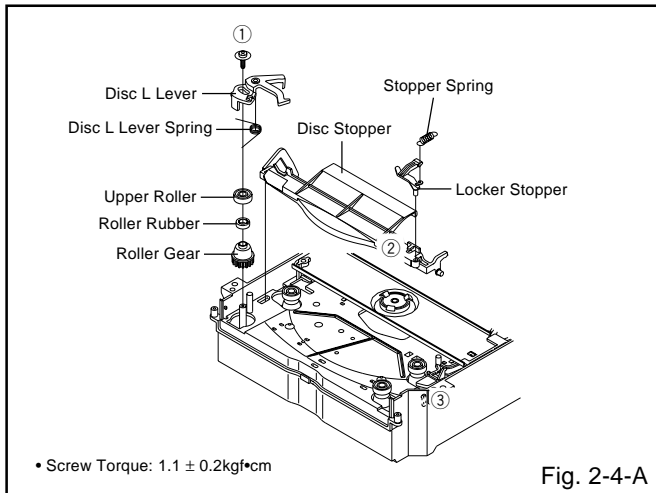

Fig. 2-4-A

NOTE

1. In case of the Upper Roller installation, install correctly as Fig. 2-4-B.

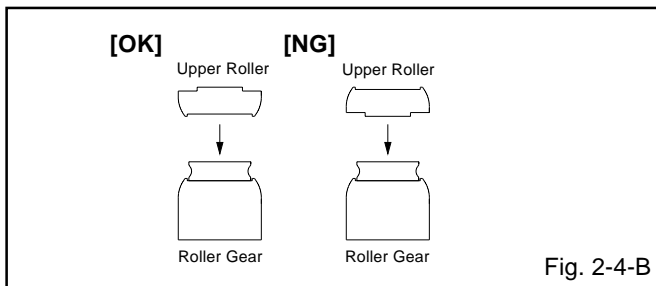

Fig. 2-4-B

2-5: RACK LOADING/RACK GEAR/GUIDE ARM SPRING/MID RACK GEAR (Refer to Fig. 2-5)

1. Remove the Guide Arm Spring.
2. Unlock the 3 supports ① and remove the Rack Loading.
3. Remove the Rack Gear and Mid Rack Gear.

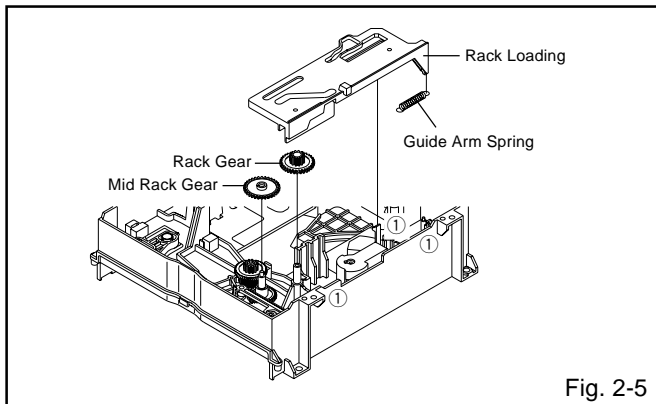

Fig. 2-5

2-6: LINK R ASS'Y/LINK L/LINK MID/LINK SPRING (Refer to Fig. 2-6)

1. Remove the screw ①.
2. Remove the Link Spring.
3. Unlock the support ② and remove the Link L.
4. Unlock the support ③ and remove the Link Mid.
5. Remove the screw ④.
6. Unlock the 4 supports ⑤ and remove the Link R Ass'y.

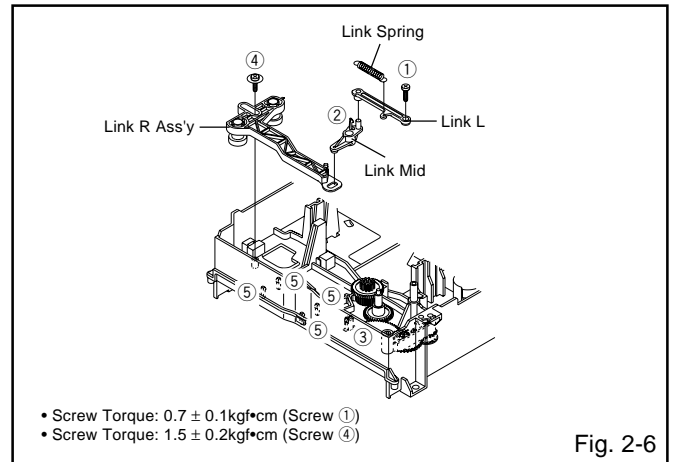

Fig. 2-6

2-7: ARM ROLLER ASS'Y/MID ROLLER 1/2 GEAR/TERMINAL GEAR (Refer to Fig. 2-7)

1. Remove the screw ①.
2. Remove the Arm Roller Ass'y.
3. Remove the Terminal Gear and Mid Roller Gear 1.
4. Unlock the support ② and remove the Mid Roller Gear 2.

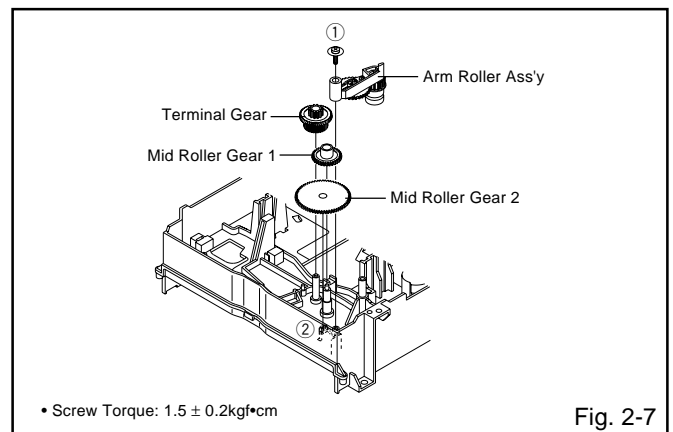
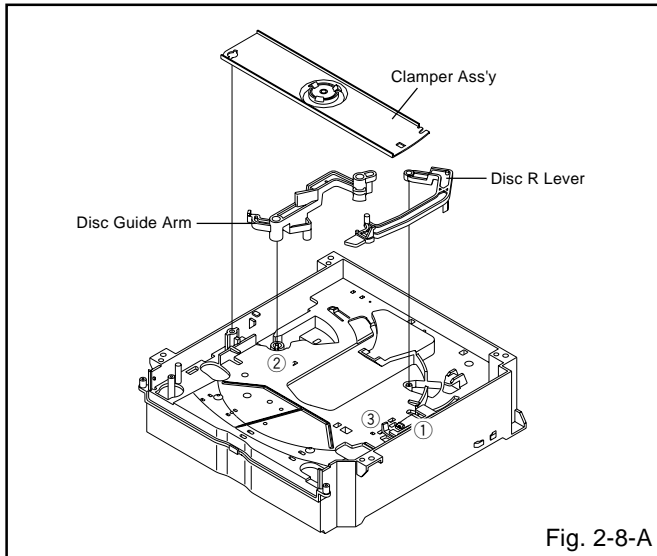

Fig. 2-7

DISASSEMBLY INSTRUCTIONS

2-8: CLAMPER ASS'Y/DISC GUIDE ARM/DISC R LEVER (Refer to Fig. 2-8-A)

1. Unlock the support ① and remove the Clamper Ass'y.
2. Unlock the support ② and remove the Disc Guide Arm.
3. Unlock the support ③ and remove the Disc R Lever.



NOTE

1. When installing the Clamper Ass'y, check if the Clamper Ass'y is locked correctly as Fig. 2-8-B.

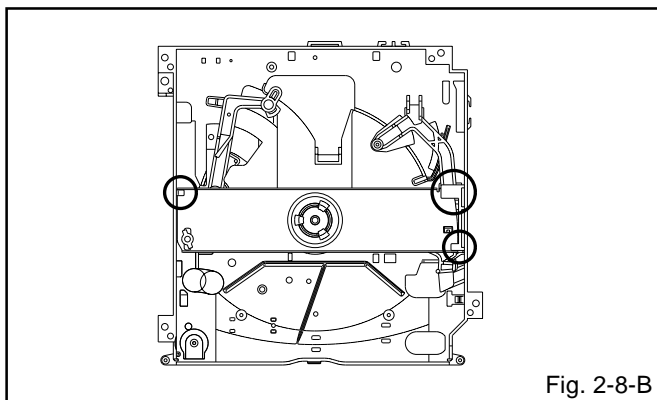

DISASSEMBLY INSTRUCTIONS

3. REMOVAL AND INSTALLATION OF FLAT PACKAGE IC

REMOVAL

1. Put the Masking Tape (cotton tape) around the Flat Package IC to protect other parts from any damage. (Refer to Fig. 3-1.)

NOTE

Masking is carried out on all the parts located within 10 mm distance from IC leads.

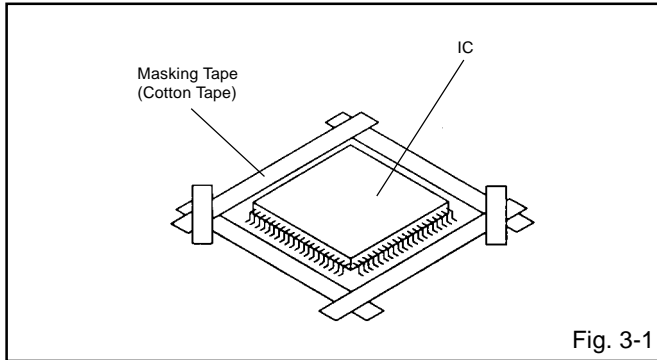

2. Heat the IC leads using a blower type IC desoldering machine. (Refer to Fig. 3-2.)

NOTE

Do not add the rotating and the back and forth directions force on the IC, until IC can move back and forth easily after desoldering the IC leads completely.

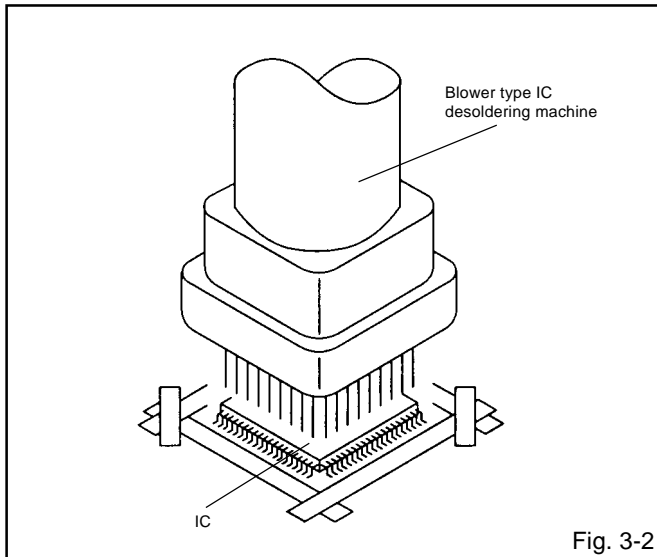

3. When IC starts moving back and forth easily after desoldering completely, pickup the corner of the IC using a tweezers and remove the IC by moving with the IC desoldering machine. (Refer to Fig. 3-3.)

NOTE

Some ICs on the PCB are affixed with glue, so be careful not to break or damage the foil of each IC leads or solder lands under the IC when removing it.

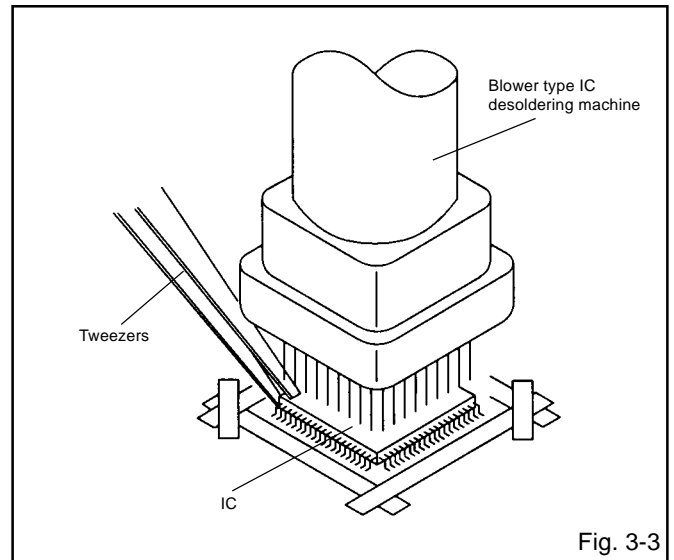

4. Peel off the Masking Tape.
5. Absorb the solder left on the pattern using the Braided Shield Wire. (Refer to Fig. 3-4.)

NOTE

Do not move the Braided Shield Wire in the vertical direction towards the IC pattern.

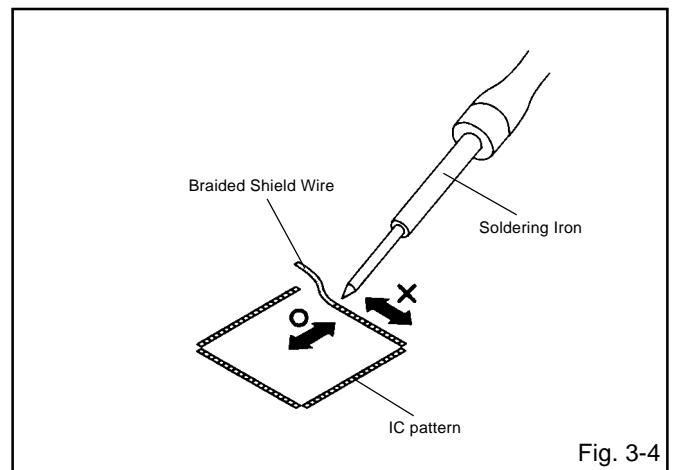

DISASSEMBLY INSTRUCTIONS

INSTALLATION

1. Take care of the polarity of new IC and then install the new IC fitting on the printed circuit pattern. Then solder each lead on the diagonal positions of IC temporarily. **(Refer to Fig. 3-5.)**

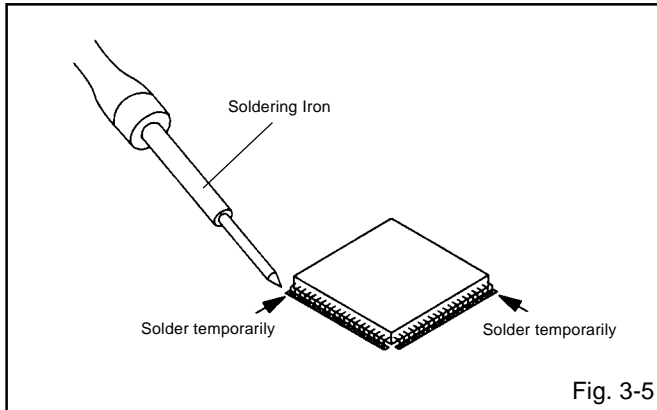

2. Supply the solder from the upper position of IC leads sliding to the lower position of the IC leads. **(Refer to Fig. 3-6.)**

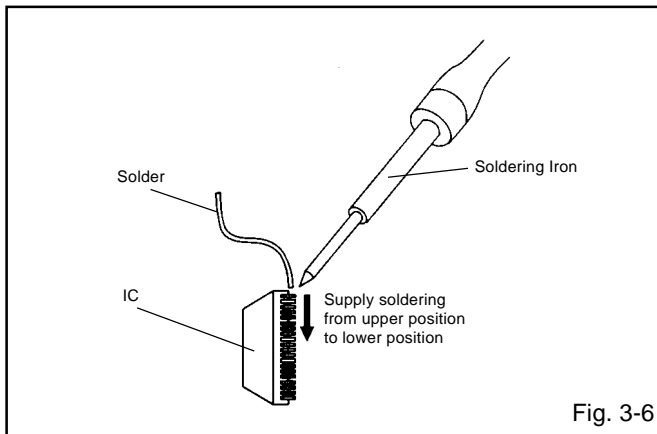

3. Absorb the solder left on the lead using the Braided Shield Wire. **(Refer to Fig. 3-7.)**

NOTE

Do not absorb the solder to excess.

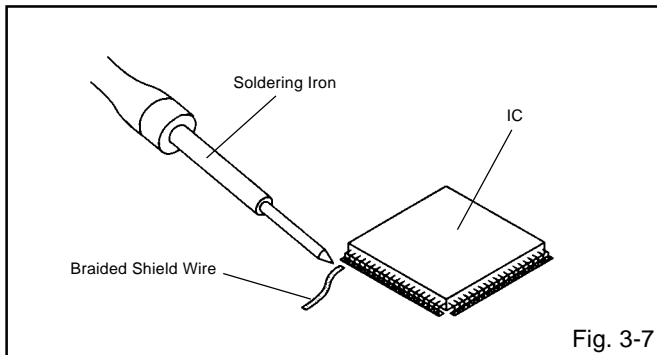

4. When bridge-soldering between terminals and/or the soldering amount are not enough, resolder using a Thin-tip Soldering Iron. **(Refer to Fig. 3-8.)**

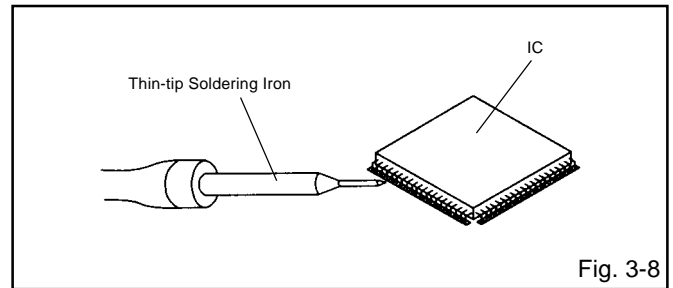

5. Finally, confirm the soldering status on four sides of the IC using a magnifying glass. Confirm that no abnormality is found on the soldering position and installation position of the parts around the IC. If some abnormality is found, correct by resoldering.

NOTE

When the IC leads are bent during soldering and/or repairing, do not repair the bending of leads. If the bending of leads are repaired, the pattern may be damaged. So, be always sure to replace the IC in this case.

SERVICE MODE LIST

This unit provided with the following SERVICE MODES so you can repair, examine and adjust easily.

To enter to the SERVICE MODE function, press and hold both buttons simultaneously on the main unit and on the remote control for more than a the standard time in the appropriate condition. (See below chart.)

Set Condition	Set Key	Remocon Key	Standard Time	Operations
TV mode	VOL. DOWN (Minimum)	0	2 sec.	Releasing of V-CHIP PASSWORD.
TV mode	VOL. DOWN (Minimum)	1	2 sec.	Initialization of factory TV data. NOTE: If you set factory initialization, the memories are reset such as the channel setting, and the POWER ON total hours.
DVD mode (No disc)	VOL. DOWN (Minimum)	4	2 sec.	Initialization of factory DVD data. NOTE: The function will only work without the setting of DVD disc at DVD mode.
DVD mode (No disc)	VOL. DOWN (Minimum)	5	2 sec.	DVD Write mode. Refer to the "RE-WRITE FOR DVD FIRMWARE". NOTE: The function will only work without the setting of DVD disc at DVD mode.
TV mode	VOL. DOWN (Minimum)	6	2 sec.	POWER ON total hours are displayed on the screen. Refer to the "CONFIRMATION OF HOURS USED" . Can be checked of the INITIAL DATA of MEMORY IC. Refer to the "WHEN REPLACING EEPROM (MEMORY) IC".
TV mode	VOL. DOWN (Minimum)	8	2 sec.	Check of the SUM DATA and MICON VERSION on the screen. Refer to the "CONFIRMATION OF HOURS USED".
ALL mode	VOL. DOWN (Minimum)	9	2 sec.	Display of the Adjustment MENU on the screen. Refer to the "ELECTRICAL ADJUSTMENT" (On-Screen Display Adjustment).
DVD mode (No disc)	STOP	1	2 sec.	Region setting. Refer to the "RE-WRITE FOR DVD FIRMWARE".
DVD mode (No disc)	STOP	7	2 sec.	Releasing of PARENTAL LOCK. Refer to the "PARENTAL CONTROL - RATING LEVEL". NOTE: The function will only work without the setting of DVD disc at DVD mode.
DVD mode (STOP)	STOP	9	2 sec.	The disk cannot be taken out. Refer to the "TRAY LOCK". NOTE: No indications on the screen when the Tray Lock is setting.

CONFIRMATION OF HOURS USED

POWER ON total hours can be checked on the screen. Total hours are displayed in 16 system of notation.

NOTE: If you set a factory initialization, the total hours is reset to "0".

1. Turn on the POWER, and set to the TV mode.
2. Set the VOLUME to minimum.
Press both VOL. DOWN button on the set and Channel button (6) on the remote control for more than 2 seconds.
3. After the confirmation of using hours, turn off the power.

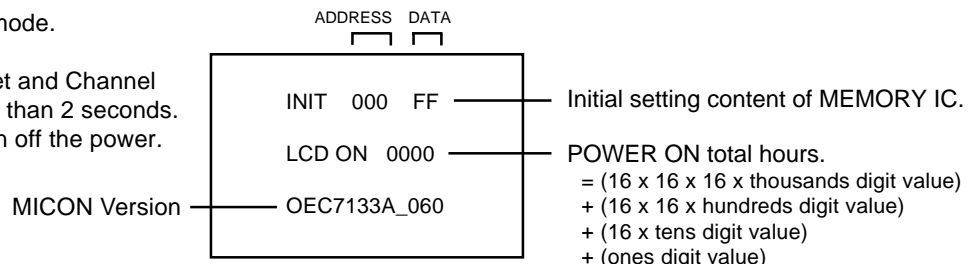
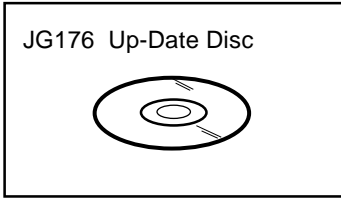

FIG. 1

SERVICING FIXTURES AND TOOLS



Ref. No.	Part No.	Parts Name	Remarks
JG176	APJG176076	Up-Date Disc	Up-Date of the Firmware

RE-WRITE FOR DVD FIRMWARE

1. Turn on the power, and set the DVD mode.
 2. Confirm that the "No Disc" will be appeared on the screen.
 3. Press both VOL. DOWN button on the set and Channel button **(5)** on the remote control for more than 2 seconds.
 4. Press VOL. UP/DOWN button on the unit to check if all the keys on the unit do not function.
NOTE: To check if DVD Write mode is set.
When inserting Up-Date Disc at Non DVD Write mode, the read error will happen.
 5. Insert the Up-Date Disc. **(Refer to SERVICING FIXTURE AND TOOLS)**
 6. Automatic read will start and "Firmware upgrade Please Wait" will be displayed on the screen. At this time, the horizontal noise lines may appear. But no problem.
NOTE: Do not turn off the unit on the way or operate the keys on the unit and remocon.
Up-Date error will happen and can not be done with the Up-Date of Up-Date Disc.
 7. After the Up-Date, Logo screen will appear.
 8. Unplug the AC cord, then plug it in.
- After the write, set to the initializing of shipping.**
9. Turn on the power, and set the DVD mode.
 10. Press both VOL. DOWN button on the set and Channel button **(4)** on the remote control for more than 2 seconds. The "INITIALIZE 5 ---> COMPLETE" will appear on the screen.
 11. Then unplug the AC cord, and plug it in.

CHECK FOR THE FIRMWARE VERSION

12. Turn on the power, and set the DVD mode.
13. Press both Channel button **(1)** on the remote control and the STOP button on the set for more than 2 seconds. Firmware version will be displayed on the top left of the screen.

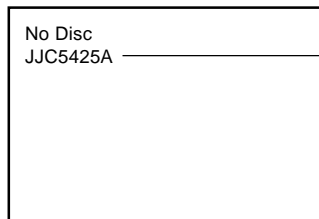

J J C 5 4 2 5 A

Fixed

Released times on the same date

Release date (Example: 2005.4.25)

When the changed version displays, the Re-write will be completed.

A = October
 B = November
 C = December

14. Turn off the power

CONFIRMATION OF CHECK SUM

Initial total of MEMORY IC can be checked on the screen. Total hours are displayed in 16 system of notation.

NOTE: If you set a factory initialization, the total hours is reset to "0".

1. Turn on the POWER, and set to the TV mode.
2. Set the VOLUME to minimum.
Press both VOL. DOWN button on the set and Channel
3. button **(8)** on the remote control for more than 2 seconds.
4. After the confirmation of each check sum, turn off the power.

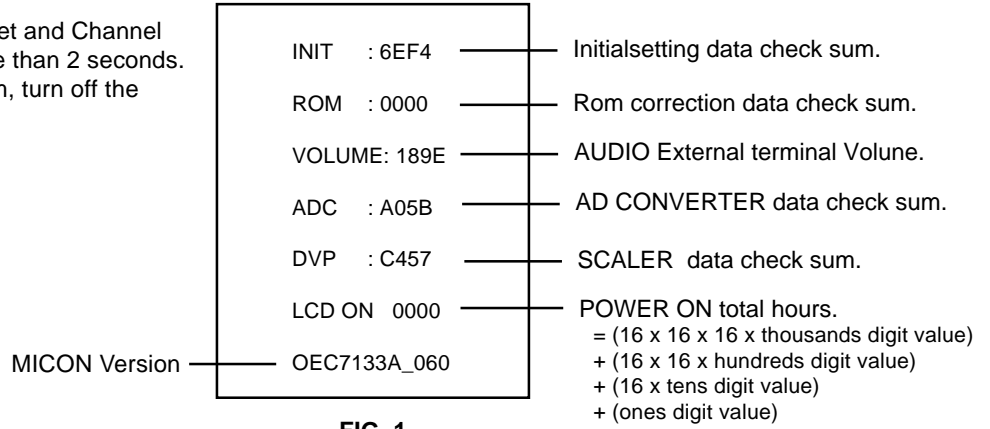

FIG. 1

WHEN REPLACING EEPROM (MEMORY) IC

If a service repair is undertaken where it has been required to change the MEMORY IC, the following steps should be taken to ensure correct data settings while making reference to TABLE 1.

1. Turn on the POWER, and set to the TV mode.
2. Set the VOLUME to minimum.
3. Press both VOL. DOWN button on the set and Channel button **(6)** on the remote control for more than 2 seconds.
ADDRESS and DATA should appear as FIG 1.

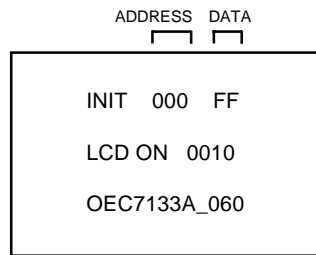

FIG. 1

4. ADDRESS is now selected and should "blink". Using the UP/DOWN button on the remote, step through the ADDRESS until Press RIGHT/LEFT button to select DATA. When DATA is selected, it will "blink".
5. Again, step through the DATA using UP/DOWN button until required DATA value has been selected.
6. Pressing RIGHT/LEFT button will take you back to ADDRESS for further selection if necessary.
7. Repeat steps 3 to 6 until all data has been checked.
8. When satisfied correct DATA has been entered, turn POWER off (return to STANDBY MODE) to finish DATA input.

After the data input, set to the initializing of shipping.

9. Turn POWER on.
10. Press both VOL. DOWN button on the set and Channel button **(1)** on the remote control for more than 2 seconds.
11. After the finishing of the initializing of shipping, the unit will turn off automatically.
The unit will now have the correct DATA for the new MEMORY IC.

WHEN REPLACING EEPROM (MEMORY) IC

INIT	+0	+1	+2	+3	+4	+5	+6	+7	+8	+9	+A	+B	+C	+D	+E	0F
000	FF	3F	01	99	EF	08	23	F9	01	30	80	55	B3	36	03	60
010	05	12	1F	24	40	45	5D	62	45	4A	19	00	13	57	00	00
020	40	08	3E	00	00	00	00	00	00	00	00	00	00	00	00	00
030	72	99	59	68	99	59	59	99	59	40	20	88	0D	45	80	40
040	46	63	68	49	53	65	6A	30	00	5C	62	00	00	00	00	00
050	00	00	00	D0	73	14	1C	35	30	16	00	00	00	00	00	FC
060	FC	FA	F8	F6	15	F5	08	0D	07	42	73	00	00	00	06	F4
070	02	12	22	00	0D	F0	F0	F0	F0	F0	26	03	26	03	1E	0F
080	1E	0F	04	18	91	40	00	00	00	00	00	00	00	00	00	00
090	00	00	3C	20	3C	20	3C	20	3C	20	00	23	27	2B	2F	32
0A0	36	3A	3E	42	46	4A	4B	4D	4F	51	53	55	57	59	5B	5D
0B0	5F	61	63	66	67	68	69	6A	6B	6C	6D	6E	6F	70	71	71
0C0	72	72	72	73	73	73	74	74	74	75	75	75	76	75	76	76
0D0	76	76	77	77	77	77	78	78	78	78	79	42	00	00	00	EF
0E0	06	04	0B	01	00	01	07	3C	4F	02	0A	14	3F	49	00	00
0F0	00	00	00	00	00	50	19	32	19	00	19	44	43	40	40	40
100	10	92	FF	FF	10	30	B0	D0	F0	7B	30	57	7A	15	82	D9
110	4D	8C	28	70	20	60	10	80	20	A0	00	2C	0D	00	88	0F
120	84	10	C0	E0	12	19	00	F0	0F	00	7F	12	18	EB	83	7F
130	F9	5E	CA	52	18	F7	4C	33	4C	29	73	74	74	74	75	75
140	23	27	2B	2F	32	36	3A	3E	42	46	4A	4B	4D	4F	51	53
150	55	57	59	5B	5D	5F	61	63	66	67	68	69	6A	6B	6C	6D
160	6E	6F	70	71	71	72	72	72	73	73	73	74	74	74	75	75
170	75	76	75	76	76	76	76	77	77	77	77	78	78	78	78	79
600	31	F0	28	1F	08	08	20	80	80	80	7F	7F	7F	66	6E	80
610	20	04	04	02	00	00	00	01	00	00	00	00	00	00	00	00
620	38	30	20	10	10	08	20	80	80	80	7F	7F	7F	66	6E	B8
630	28	04	04	02	00	00	00	01	00	00	00	00	00	00	00	00
640	41	F0	60	A0	08	08	20	80	80	80	7F	7F	7F	66	6E	80
650	20	04	04	02	00	00	00	01	00	00	00	00	00	00	00	00
660	53	F0	70	A5	08	08	20	80	80	80	7F	7F	7F	66	6E	80
670	20	04	04	02	00	00	00	01	00	00	00	00	00	00	00	00
680	67	F0	A0	C0	10	08	60	80	80	80	7F	7F	7F	66	6E	B8
690	28	04	04	02	00	00	00	01	00	00	00	00	00	00	00	00

Table 1-1

WHEN REPLACING EEPROM (MEMORY) IC

INIT	+0	+1	+2	+3	+4	+5	+6	+7	+8	+9	+A	+B	+C	+D	+E	0F
6A0	67	F0	A0	1B	10	08	60	80	80	80	7F	7F	7F	66	6E	B8
6B0	28	04	04	02	00	00	00	01	00	00	00	00	00	00	00	00
6C0	6C	90	18	F0	07	14	44	80	80	80	7B	50	7A	6B	66	B5
6D0	30	0B	0F	02	00	00	00	01	00	00	00	00	00	00	00	00
6E0	35	90	18	70	07	14	35	80	80	80	80	80	80	6B	66	B5
6F0	30	0B	0F	02	00	00	00	01	00	00	00	00	00	00	00	00
700	67	10	A8	85	2B	05	B0	80	80	80	7F	80	80	6B	66	B5
710	20	0B	0F	02	00	00	00	01	00	00	00	00	00	00	00	00
720	89	80	A8	48	2B	03	94	80	80	80	7E	80	7F	6B	66	B5
730	30	0B	0F	02	00	00	00	01	00	00	00	00	00	00	00	00
740	6C	90	18	F0	07	14	44	80	80	80	7B	50	7A	6B	66	B5
750	30	0B	0F	02	00	00	00	01	00	00	00	00	00	00	00	00
760	35	90	18	70	07	14	44	80	80	80	80	80	81	6B	66	B5
770	30	0B	0F	02	00	00	00	01	00	00	00	00	00	00	00	00
780	67	10	A8	85	2B	14	B0	80	80	80	81	80	81	6B	66	B5
790	20	0B	0F	02	00	00	00	01	00	00	00	00	00	00	00	00
7A0	89	80	A8	48	2B	66	94	80	80	80	80	80	7E	6B	66	B5
7B0	30	0B	0F	02	00	00	00	01	00	00	00	00	00	00	00	00
7C0	FF	FF	FF	FF	FF	FF	FF	FF	FF	FF	FF	FF	FF	FF	FF	FF
7D0	FF	FF	FF	FF	FF	FF	FF	FF	FF	FF	FF	FF	FF	FF	FF	FF
7E0	E7	02	FF	FF	FF	FF	FF	FF	FF	FF	FF	FF	FF	FF	FF	FF
7F0	FF	FF	FF	FF	FF	FF	FF	FF	FF	FF	FF	FF	FF	FF	FF	FF

Table 1-2

ELECTRICAL ADJUSTMENTS

1. ADJUSTMENT PROCEDURE

Read and perform these adjustments when repairing the circuits or replacing electrical parts or PCB assemblies.

CAUTION

- Use an isolation transformer when performing any service on this chassis.
- Before removing the anode cap, discharge electricity because it contains high voltage.
- When removing a PCB or related component, after unfastening or changing a wire, be sure to put the wire back in its original position.
- When you exchange IC and Transistor with a heat sink, apply silicon grease on the contact section of the heat sink. Before applying new silicon grease, remove all the old silicon grease. (Old grease may cause damages to the IC and Transistor).

Prepare the following measurement tools for electrical adjustments.

1. Pattern Generator

On-Screen Display Adjustment

1. Set the VOLUME to minimum.
2. Press the VOL. DOWN button on the set and the channel button (9) on the remote control for more than 2 seconds to display adjustment mode on the screen as shown in Fig. 1-1.

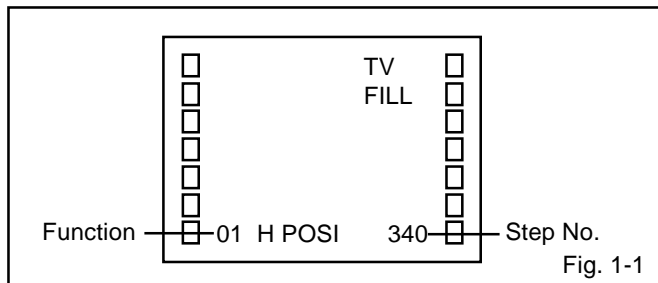

3. Use the Channel UP/DOWN button or Channel button (0-9) on the remote control to select the options shown in Fig. 1-2.
4. Press the MENU button on the remote control to end the adjustments.
5. To display the adjustment screen for TV, AV, CS, HD-MI and PC mode, press the INPUT button on the remote control. Press the VOL.DOWN button on the set and the channel (9) on the remote control for more than 2 seconds.

NO.	FUNCTION	NO.	FUNCTION
01	H POSI OSD	23	BAK LIGHT CENT
02	V POSI OSD	24	BAK LIGHT MAX
03	R DRIVE(N)	25	BAK LIGHT MIN
04	R CUT OFF(N)	26	BRIGHT CENT
05	G DRIVE(N)	27	BRIGHT MAX
06	G CUT OFF(N)	28	BRIGHT MIN
07	B DRIVE(N)	29	TINT
08	B CUT OFF(N)	30	SHARP CENTER
09	R DRIVE(C)	31	SHARP MAX
10	R CUT OFF(C)	32	SHARP MIN
11	G DRIVE(C)	33	CONTRAST CENTER(N)
12	G CUT OFF(C)	34	CONTRAST MAX(N)
13	B DRIVE(C)	35	CONTRAST MIN(N)
14	B CUT OFF(C)	36	COLOR CENT
15	R DRIVE(W)	37	COLOR MAX
16	R CUT OFF(W)	38	COLOR MIN
17	G DRIVE(W)	39	CONTRAST CENTER(C)
18	G CUT OFF(W)	40	CONTRAST MAX(C)
19	B DRIVE(W)	41	CONTRAST MIN(C)
20	B CUT OFF(W)	42	CONTRAST CENTER(W)
21	H POSI	43	CONTRAST MAX(W)
22	V POSI	44	CONTRAST MIN(W)

Fig. 1-2

2. BASIC ADJUSTMENTS

2-1: CONSTANT MAX

1. Activate the adjustment mode display of Fig. 1-1 and press the channel button (40) on the remote control to select "CONTRAST MAX(C)".
2. Press the VOL. UP/DOWN button on the remote control until the contrast step No. becomes "135".
3. Receive a broadcast and check if the picture is normal.
4. Press the INPUT button on the remote control to set to the AV mode. Then perform the above adjustments 1~3.
5. Press the INPUT button on the remote control to set to the CS mode.
6. Activate the adjustment mode display of Fig. 1-1 and press the channel button (40) on the remote control to select "CONTRAST MAX(C)".
7. Press the VOL. UP/DOWN button on the remote control until the contrast step No. becomes "125".
8. Receive a broadcast and check if the picture is normal.
9. Press the INPUT button on the remote control to set to the HD-MI mode. Then perform the above adjustments 6~8.

ELECTRICAL ADJUSTMENTS

2-2: WHITE BALANCE

1. Place the set in Aging Test for more than 15 minutes.
2. Receive the gray scale pattern from the Pattern Generator.
3. Using the remote control, set the brightness and contrast to normal position.
4. Activate the adjustment mode display of **Fig. 1-1** and press the channel button (**03**) on the remote control to select "R DRIVE(N)".
5. Press the CH. UP/DOWN button on the remote control to select the "R CUT OFF(N)", "G DRIVE(N)", "G CUT OFF(N)", "R DRIVE(C)", "R CUT OFF(C)", "G DRIVE(C)", "G CUT OFF(C)", "R DRIVE(W)", "R CUT OFF(W)", "G DRIVE(W)" or "G CUT OFF(W)".
6. Adjust the VOL. UP/DOWN button on the remote control to whiten the R CUT OFF(N), G DRIVE(N), G CUT OFF(N), R DRIVE(C), R CUT OFF(C), G DRIVE(C), G CUT OFF(C), R DRIVE(W), R CUT OFF(W), G DRIVE(W) and G CUT OFF(W), B DRIVE(W) and B CUT OFF(W) at each step tone sections equally.
7. Perform the above adjustments 5 and 6 until the white achieved.

ELECTRICAL ADJUSTMENTS

2-3: Confirmation of Fixed Value (Step No.)

Please check if the fixed values of each the adjustment items are set correctly referring below.

NO.	FUNCTION	TV	AV	GAME	DVD	CS				HD-MI				PC					
						480i	480p	720p	1080i	480i	480p	720p	1080i	VGA	VGA70	SVGA	XGA	WXGA	WXGA44.7
01	H POSI OSD	340	340	340	340	340	340	340	340	340	340	340	340	340	340	340	340	340	340
02	V POSI OSD	85	85	85	85	85	85	85	85	85	85	85	85	85	85	85	85	85	85
03	R DRIVE (N)	154	154	154	154	154	154	154	154	154	154	154	154	120	120	120	120	120	120
04	R CUTOFF (N)	107	107	107	107	107	107	107	107	107	107	107	107						
05	G DRIVE (N)	124	124	124	124	124	124	124	124	124	124	124	124	120	120	120	120	120	120
06	G CUTOFF (N)	116	116	116	116	116	116	116	116	116	116	116	116						
07	B DRIVE (N)	120	120	120	120	120	120	120	120	120	120	120	120	120	120	120	120	120	120
08	B CUTOFF (N)	121	121	121	121	121	121	121	121	121	121	121	121						
09	R DRIVE (C)	140	140	140	140	140	140	140	140	140	140	140	140						
10	R CUTOFF (C)	122	122	122	122	122	122	122	122	122	122	122	122						
11	G DRIVE (C)	128	128	128	128	128	128	128	128	128	128	128	128						
12	G CUTOFF (C)	125	125	125	125	125	125	125	125	125	125	125	125						
13	B DRIVE (C)	128	128	128	128	128	128	128	128	128	128	128	128						
14	B CUTOFF (C)	128	128	128	128	128	128	128	128	128	128	128	128						
15	R DRIVE (W)	161	161	161	161	161	161	161	161	161	161	161	161						
16	R CUTOFF (W)	80	80	80	80	80	80	80	80	80	80	80	80						
17	G DRIVE (W)	123	123	123	123	123	123	123	123	123	123	123	123						
18	G CUTOFF (W)	92	92	92	92	92	92	92	92	92	92	92	92						
19	B DRIVE (W)	108	108	108	108	108	108	108	108	108	108	108	108						
20	B CUTOFF (W)	98	98	98	98	98	98	98	98	98	98	98	98						
21	H POSI	300	300	300	300	300	146	338	295	294	144	294	245	143	159	215	291	313	322
22	V POSI	41	41	41	41	41	29	33	34	41	29	28	29	50	20	31	32	24	23
23	BAK LIGHT CENT	128	128	128	128	128	128	128	128	128	128	128	128	128	128	128	128	128	128
24	BAK LIGHT MAX	230	230	230	230	230	230	230	230	230	230	230	230	230	230	230	230	230	230
25	BAK LIGHT MIN	00	00	00	00	00	00	00	00	00	00	00	00	00	00	00	00	00	00
26	BRIGHT CENT	124	124	125	110	124	124	124	124	124	124	124	124	118	118	118	118	118	118
27	BRIGHT MAX	150	150	150	150	150	150	150	150	150	150	150	150	150	150	150	150	150	150
28	BRIGHT MIN	70	70	70	70	70	70	70	70	70	70	70	70	70	70	70	70	70	70
29	TINT	110	110	110	110	110	122	122	122	110	122	122	122						
30	SHARP CENTER	105	105	105	105	105	105	105	105	105	105	105	105	128	128	128	128	128	128
31	SHARP MAX	255	255	255	255	255	255	255	255	255	255	255	255	255	255	255	255	255	255
32	SHARP MIN	00	00	00	00	00	00	00	00	00	00	00	00	00	00	00	00	00	00
33	CONT CENTER (N)	95	80	80	90	90	85	85	85	95	85	85	85	128	128	128	128	128	128
34	CONT MAX (N)	120	120	120	105	105	105	105	105	150	105	105	105	150	150	150	150	150	150
35	CONT MIN (N)	50	50	50	50	50	50	50	50	50	50	50	50	50	50	50	50	50	50
36	COLOR CENT	80	80	80	80	80	80	80	80	80	80	80	80						
37	COLOR MAX	127	127	127	127	127	127	127	127	127	127	127	127						
38	COLOR MIN	00	00	00	0	00	00	00	00	00	00	00	00						
39	CONT CENTER (C)	100	95	95	100	100	100	100	100	100	100	100	100						
40	CONT MAX (C)	135	135	135	125	125	120	120	120	125	120	120	120						
41	CONT MIN (C)	50	50	50	50	50	50	50	50	50	50	50	50						
42	CONT CENTER (W)	70	65	65	65	65	65	65	65	65	65	65	65						
43	CONT MAX (W)	100	100	100	100	90	90	90	90	90	90	90	90						
44	CONT MIN (W)	50	50	50	50	50	50	50	50	50	50	50	50						

ELECTRICAL ADJUSTMENTS

3. ELECTRICAL ADJUSTMENT PARTS LOCATION GUIDE (WIRING CONNECTION)

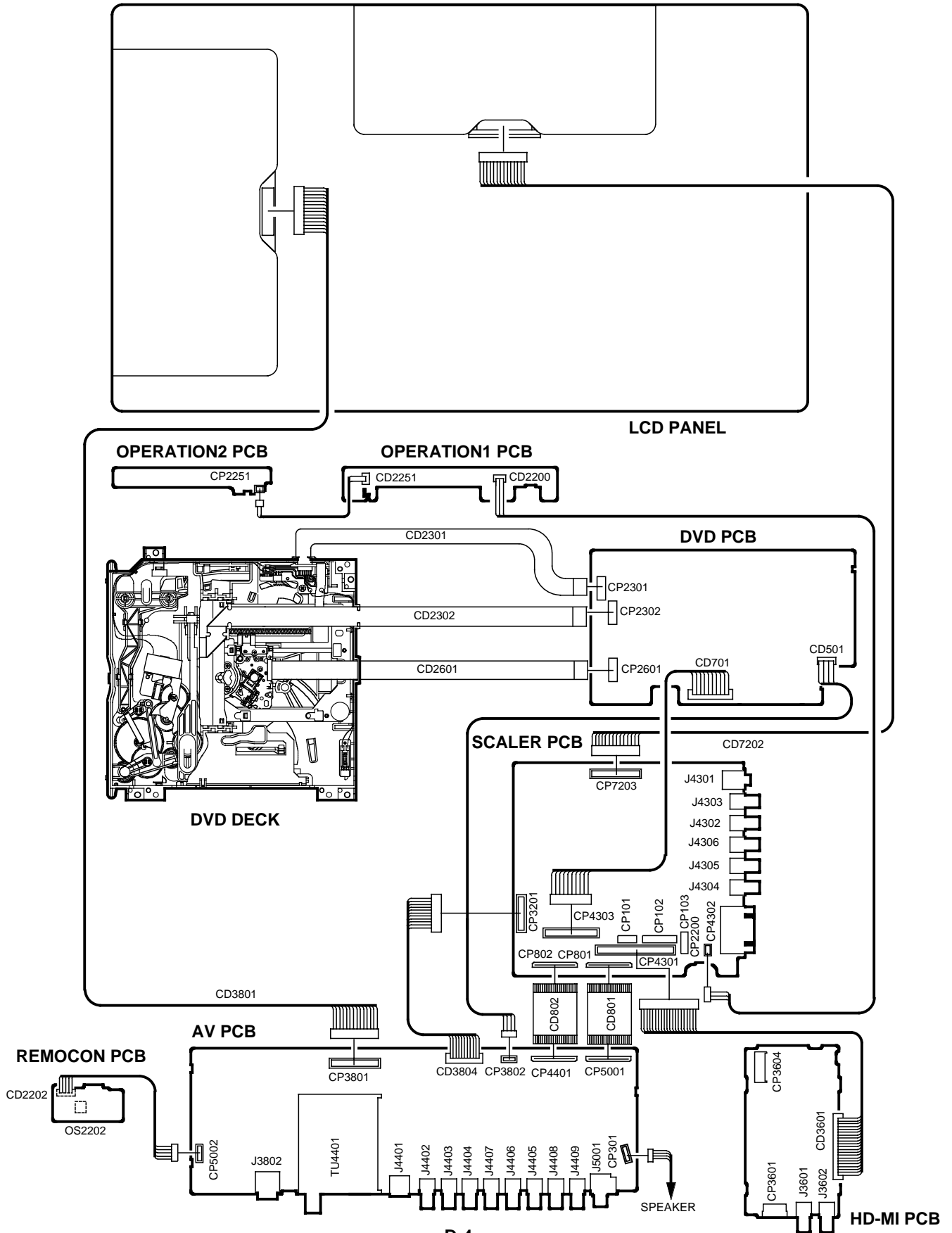

TROUBLESHOOTING GUIDE

(LCD SECTION)

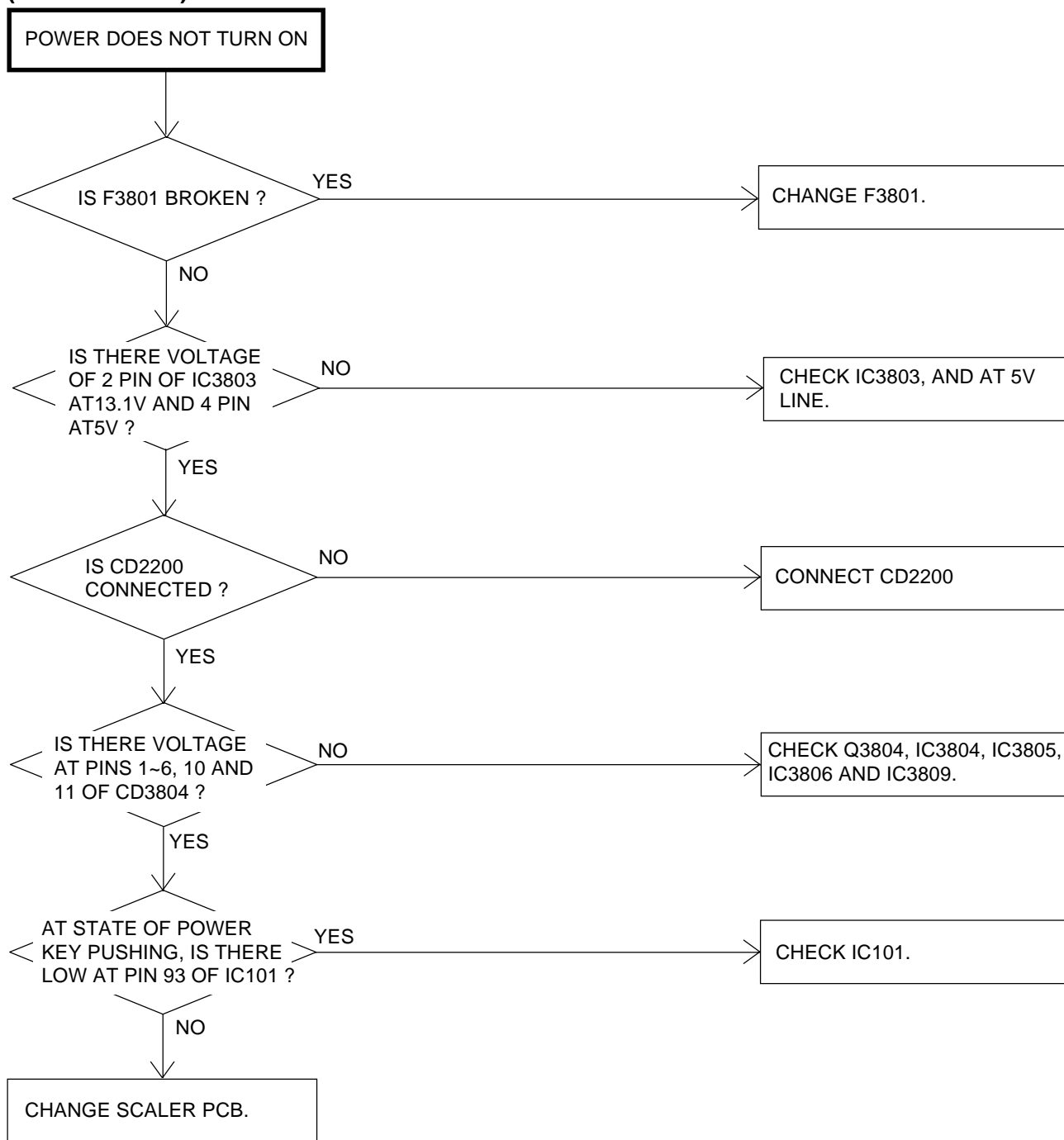

TROUBLESHOOTING GUIDE

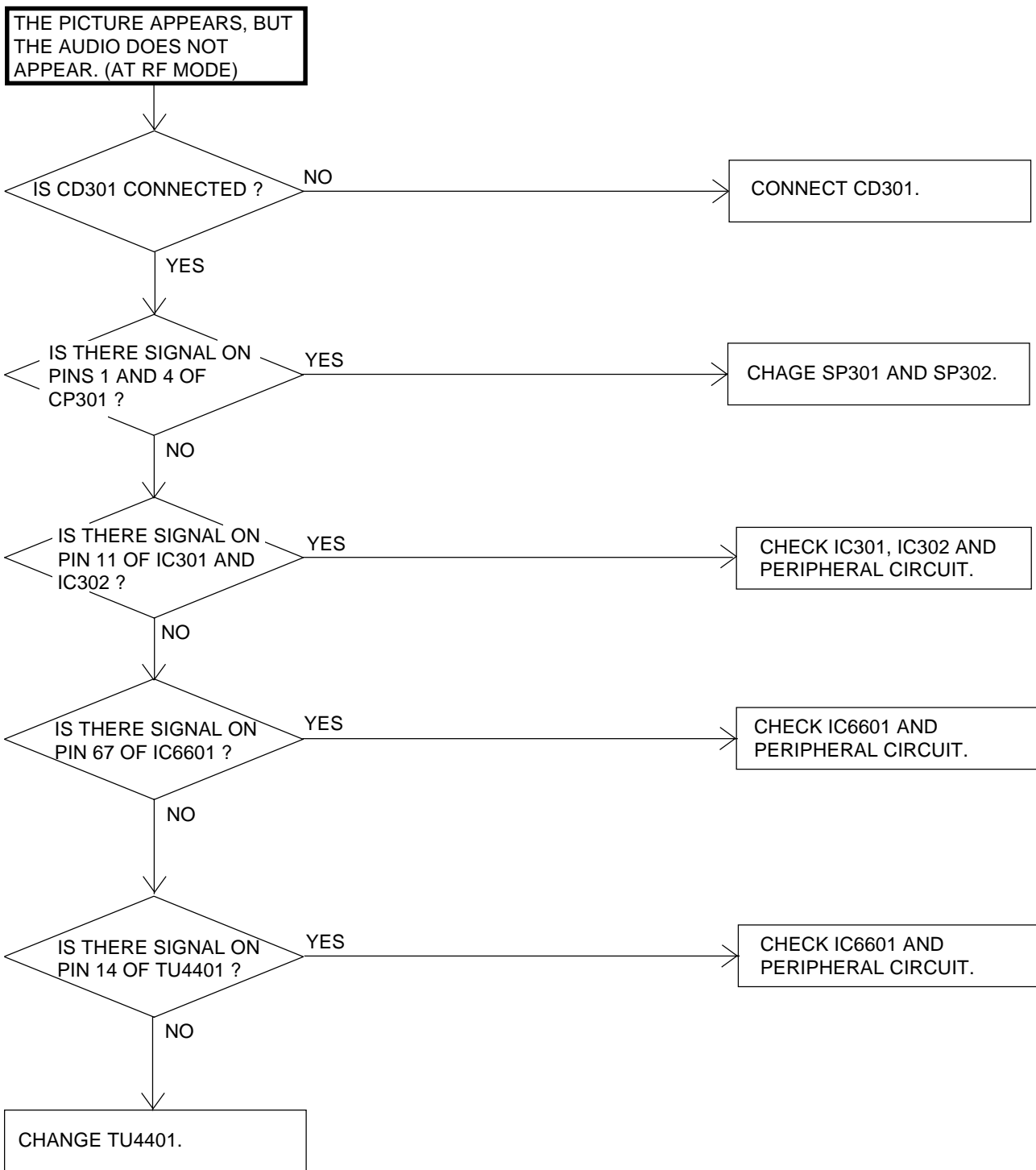

TROUBLESHOOTING GUIDE

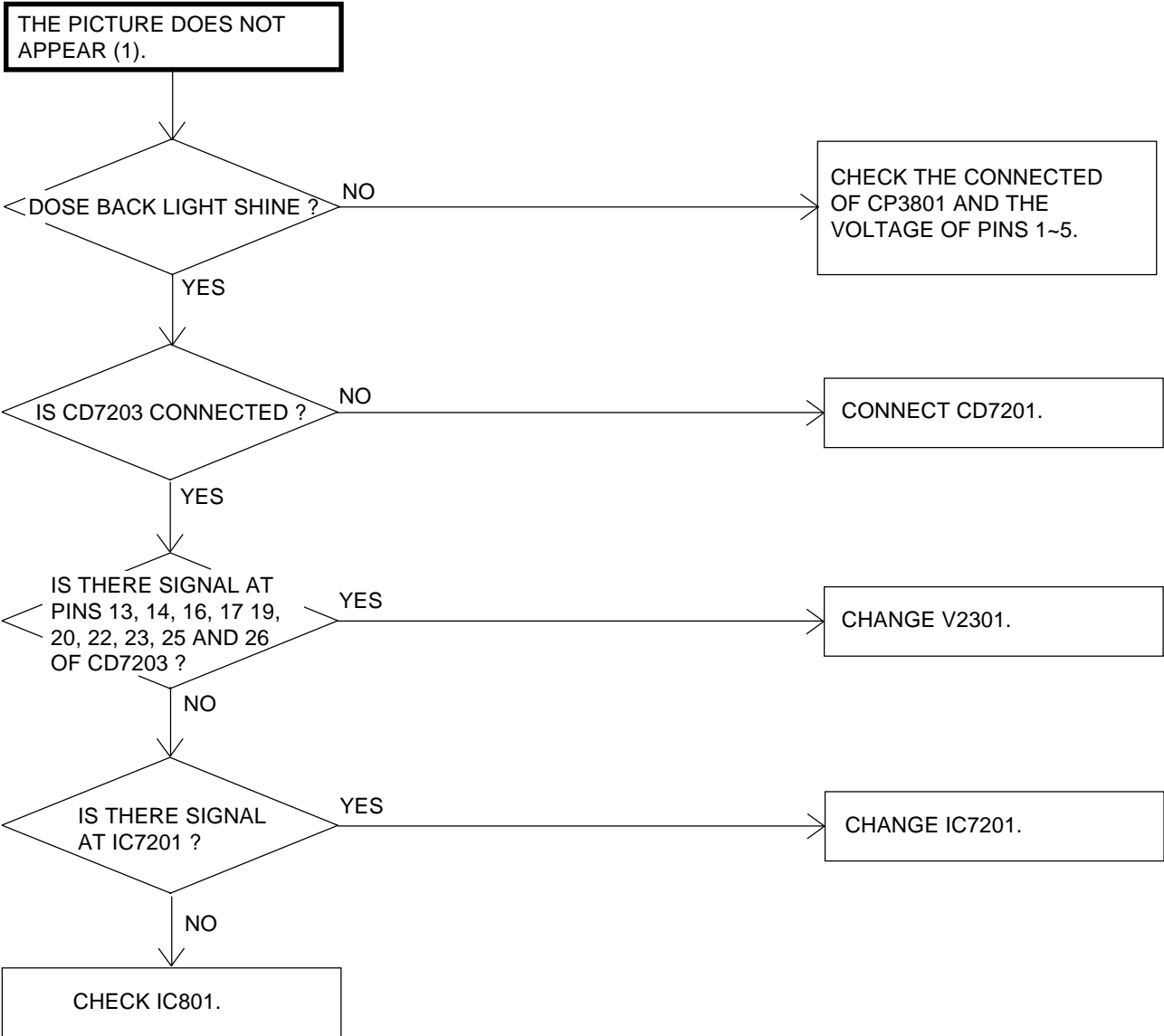

TROUBLESHOOTING GUIDE

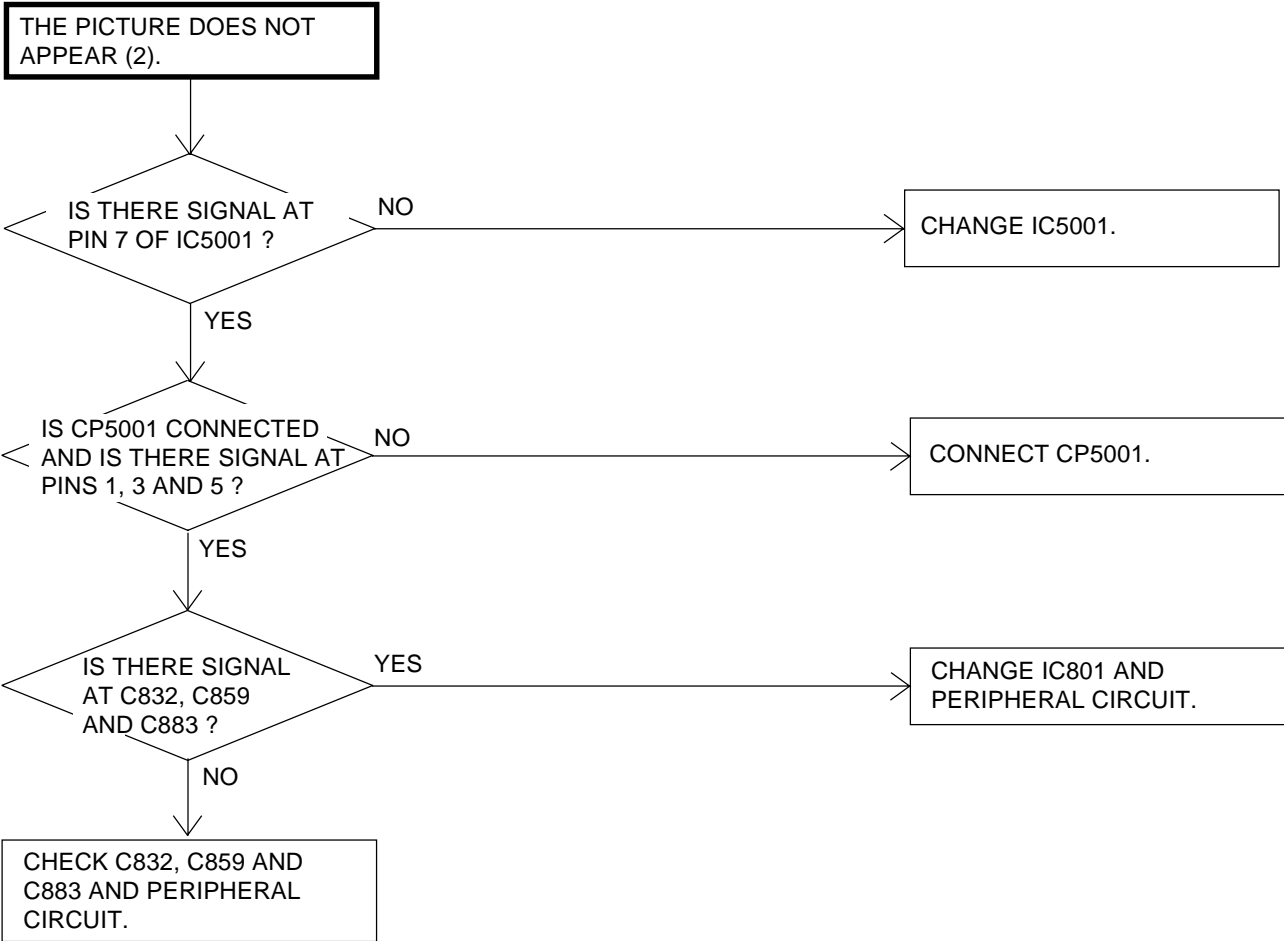

TROUBLESHOOTING GUIDE

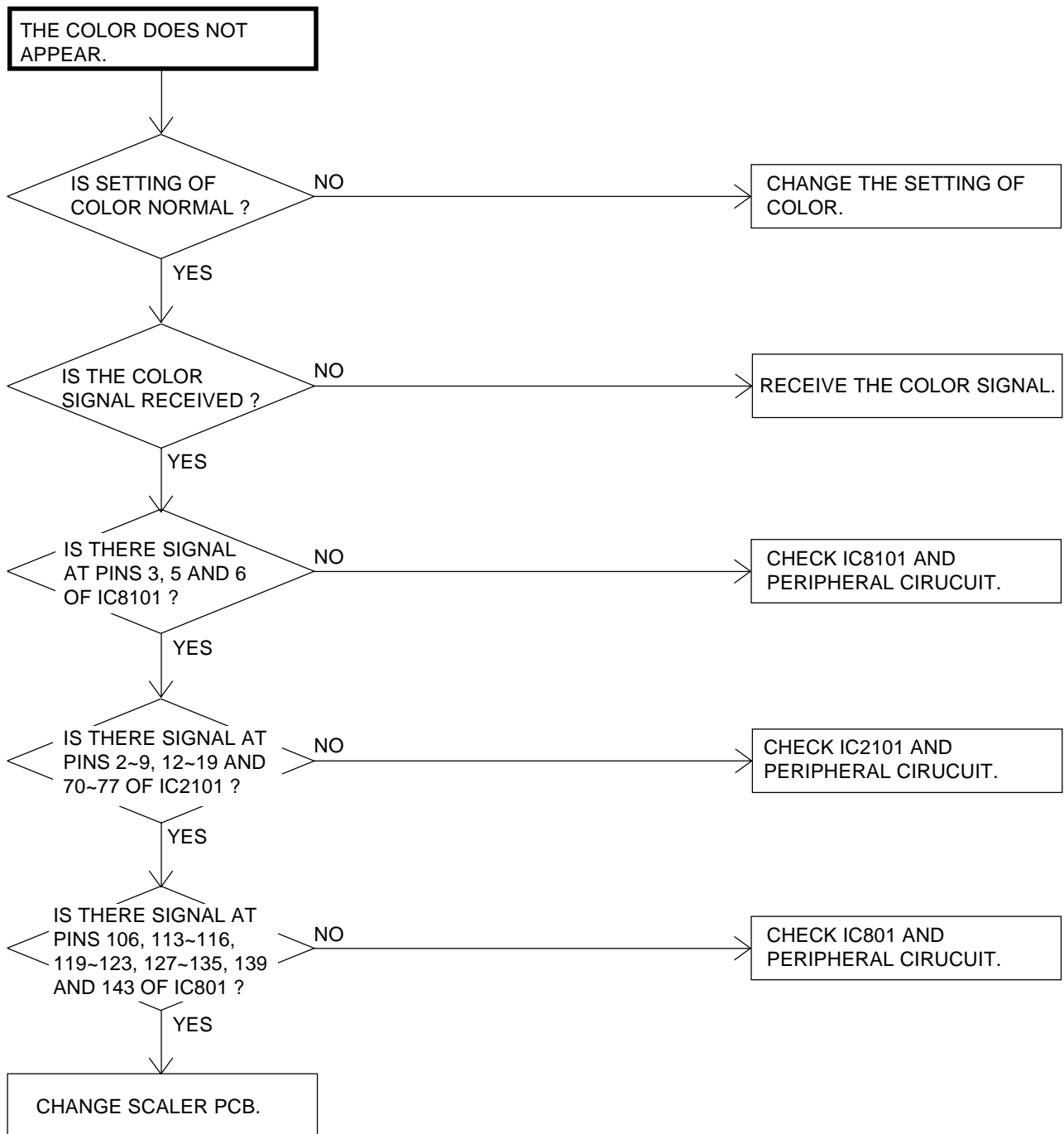

TROUBLESHOOTING GUIDE

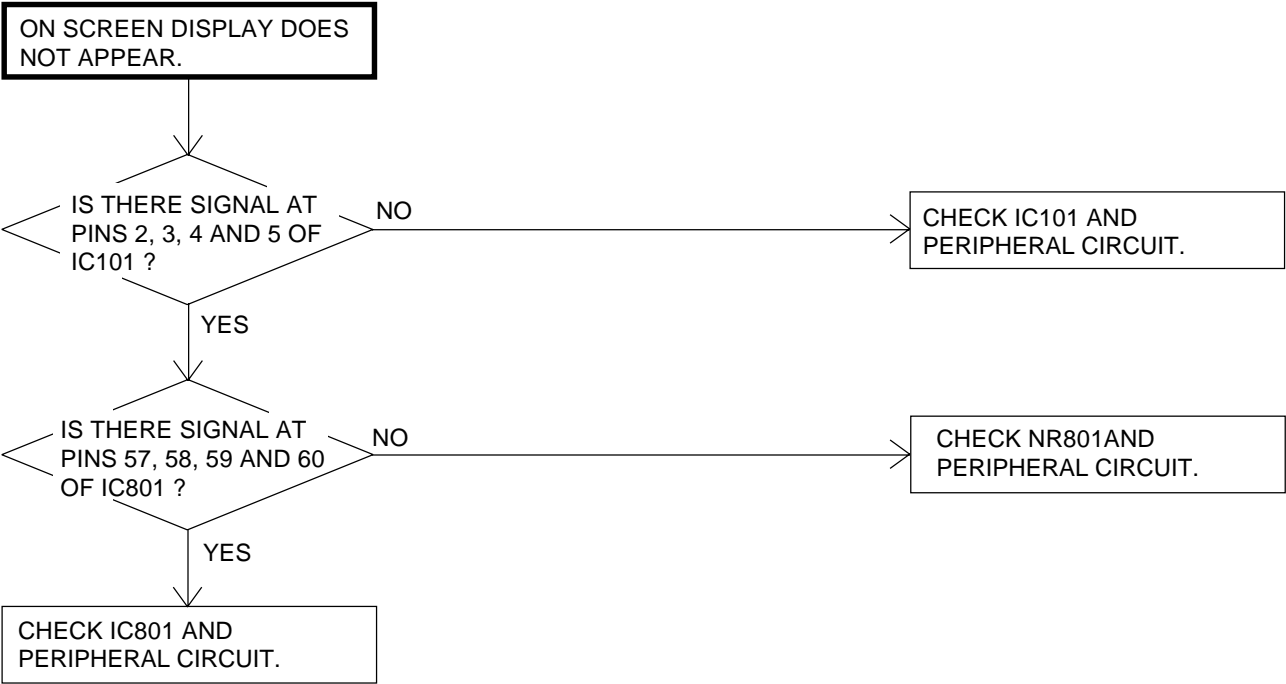

TROUBLESHOOTING GUIDE

(DVD SECTION)

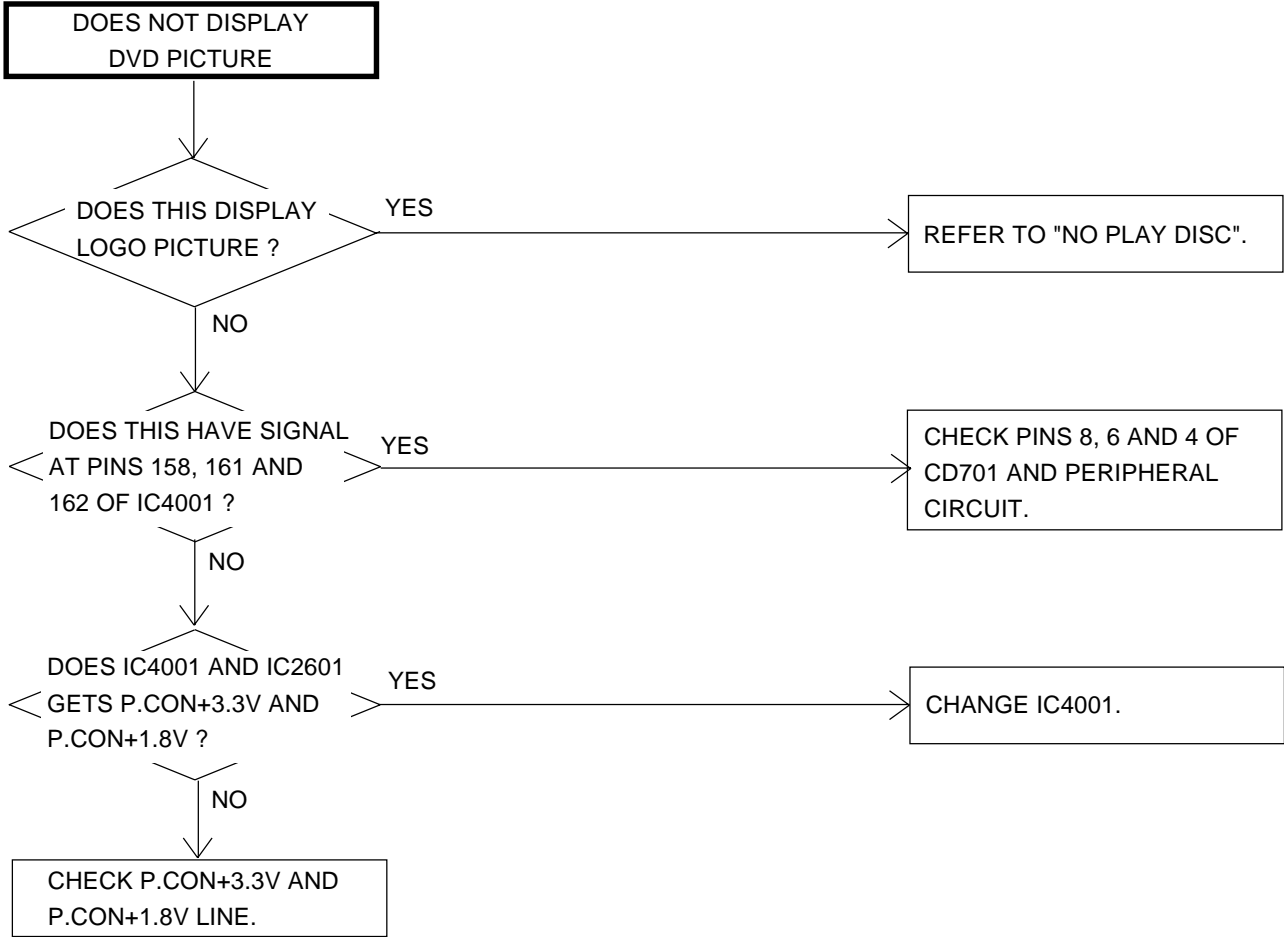

TROUBLESHOOTING GUIDE

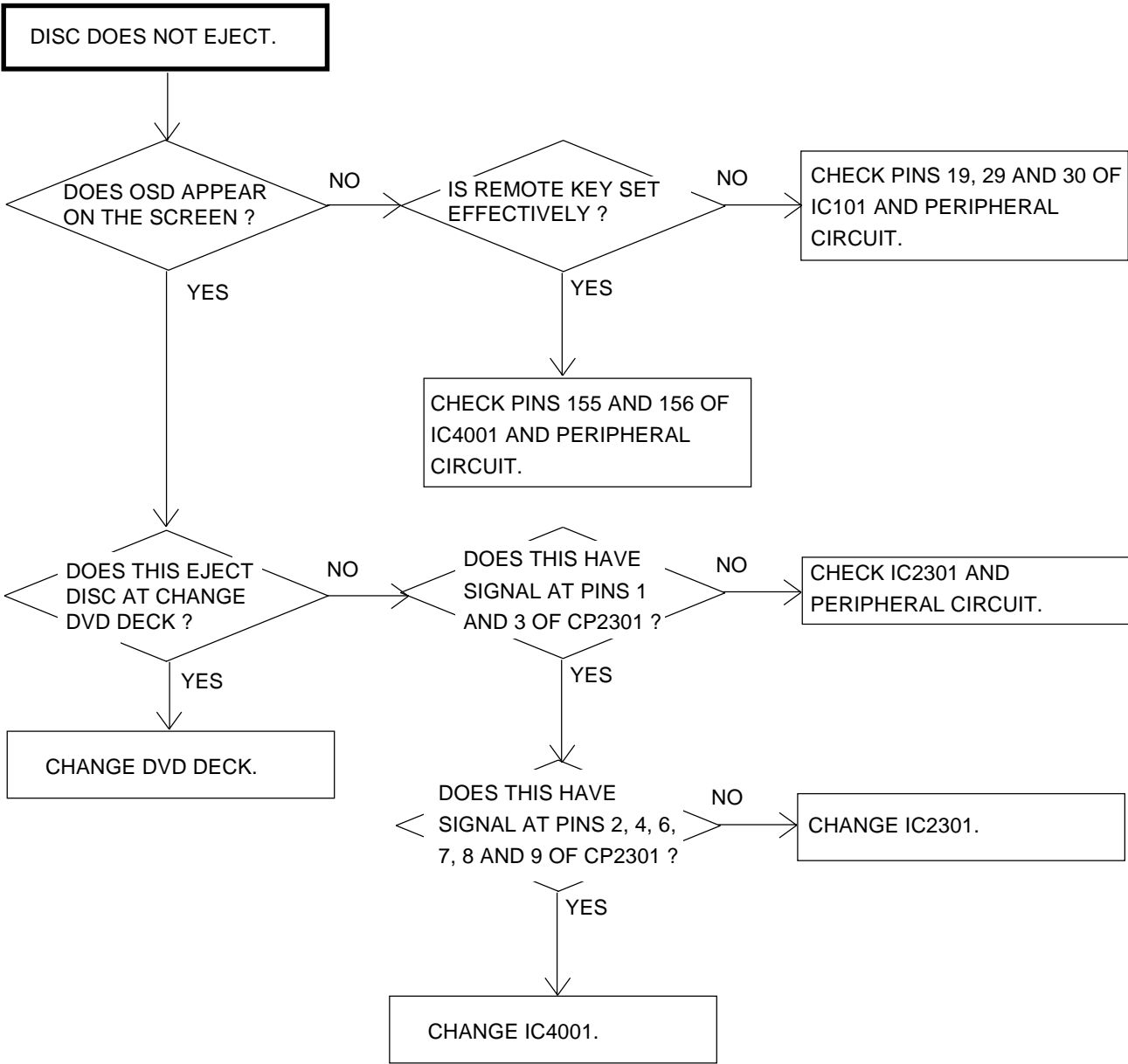

TROUBLESHOOTING GUIDE

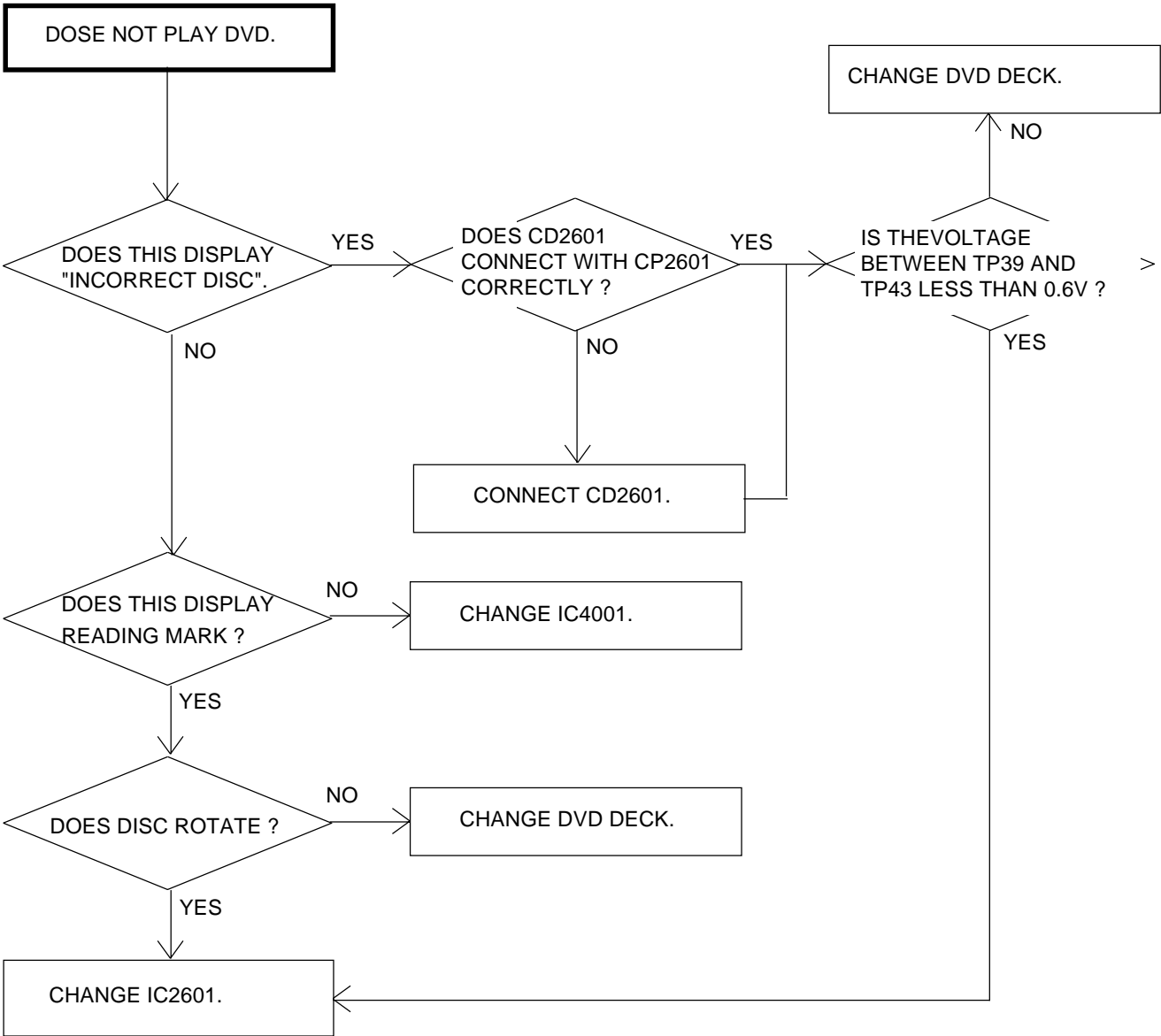

TROUBLESHOOTING GUIDE

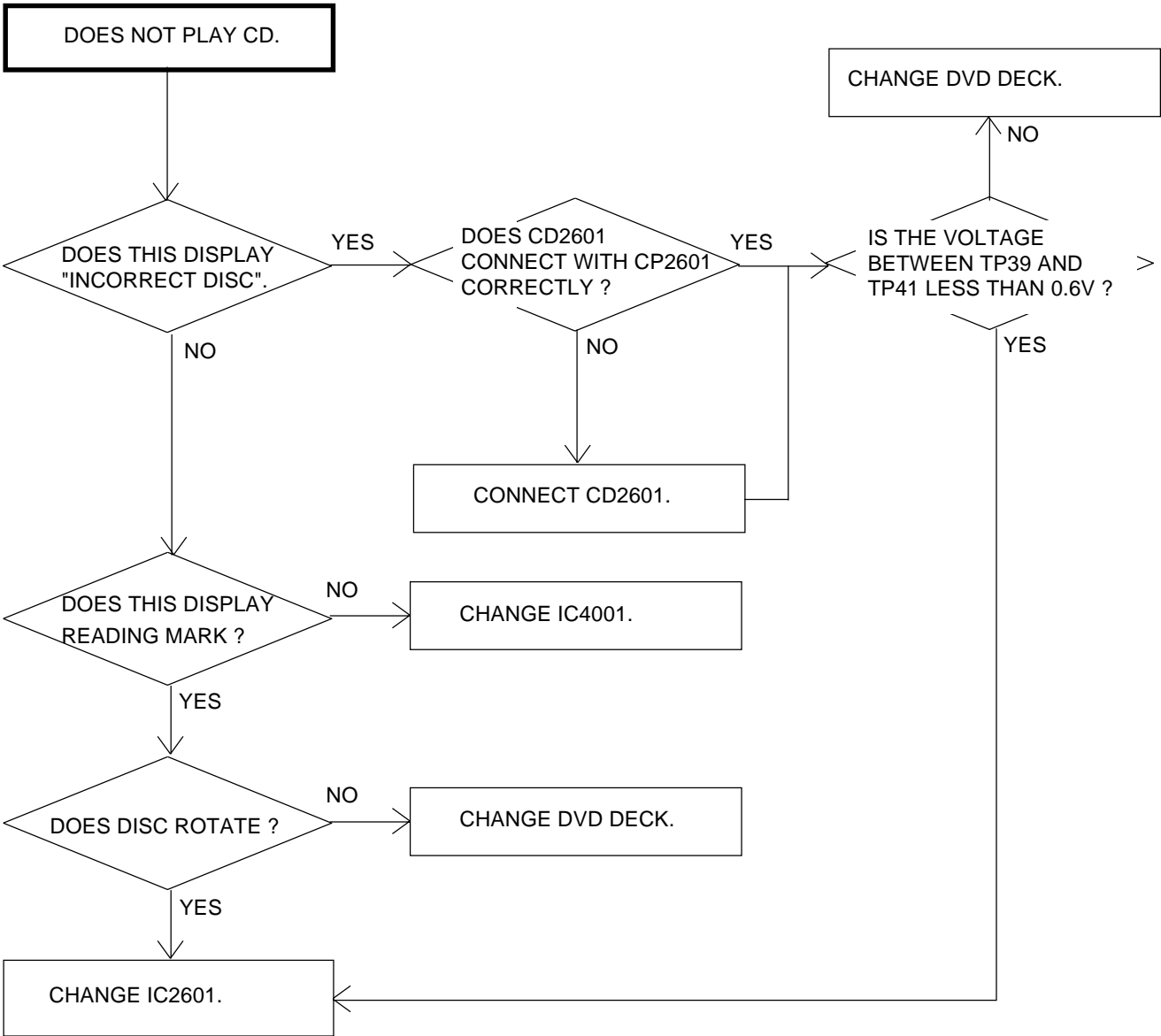

TROUBLESHOOTING GUIDE

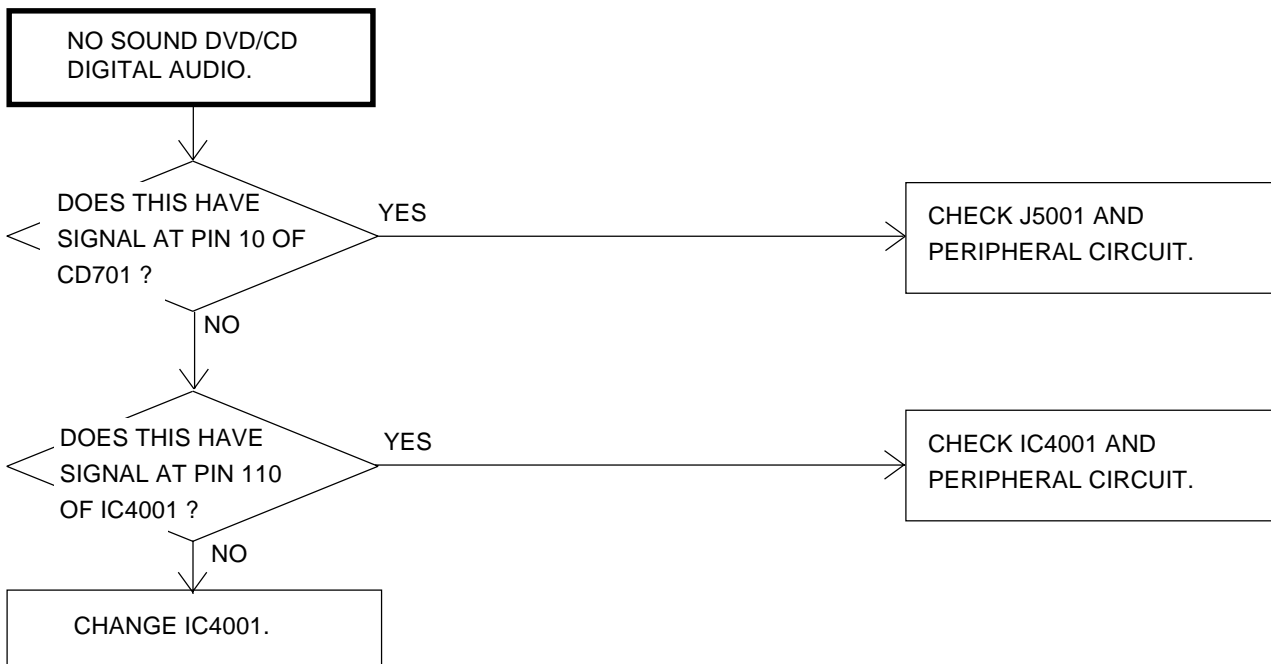
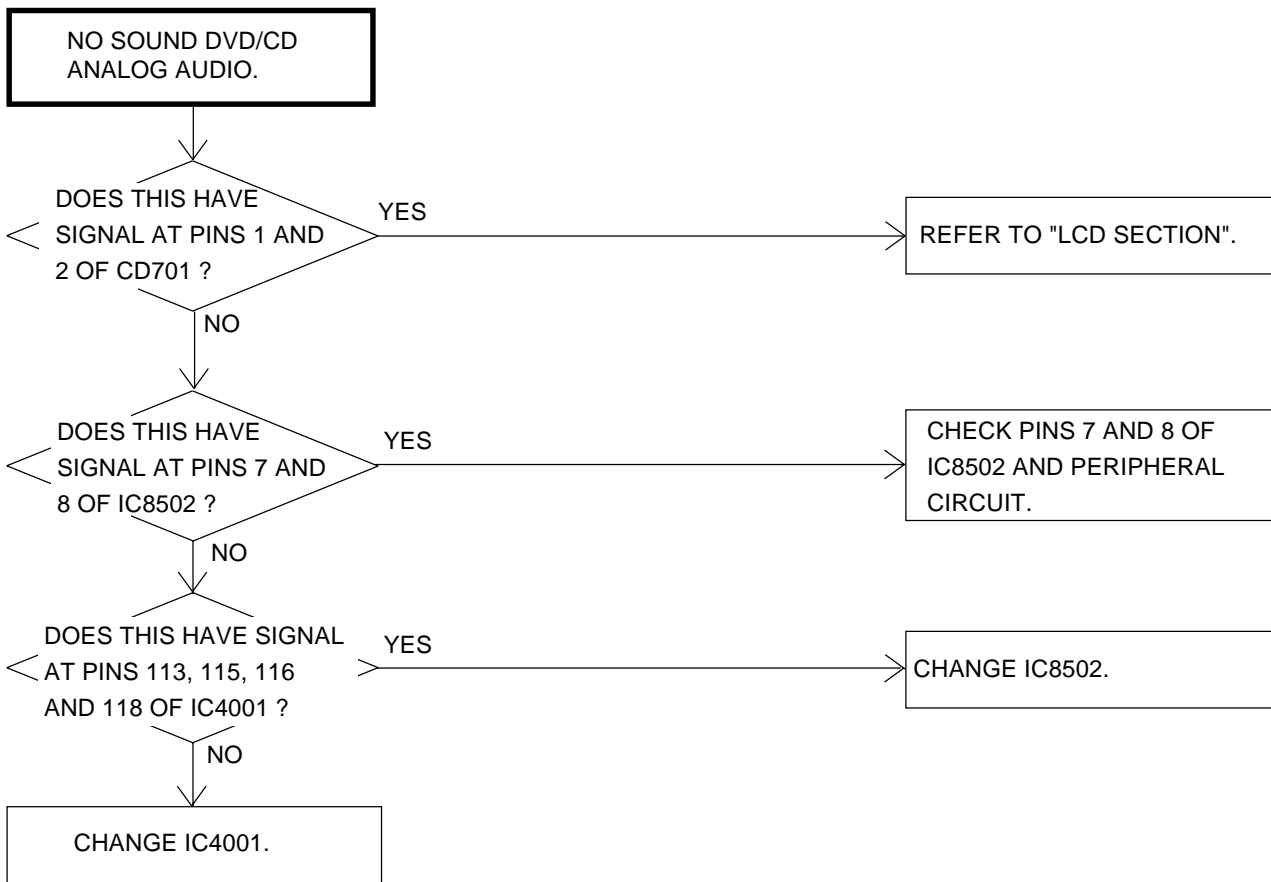

MECHANICAL EXPLODED VIEW

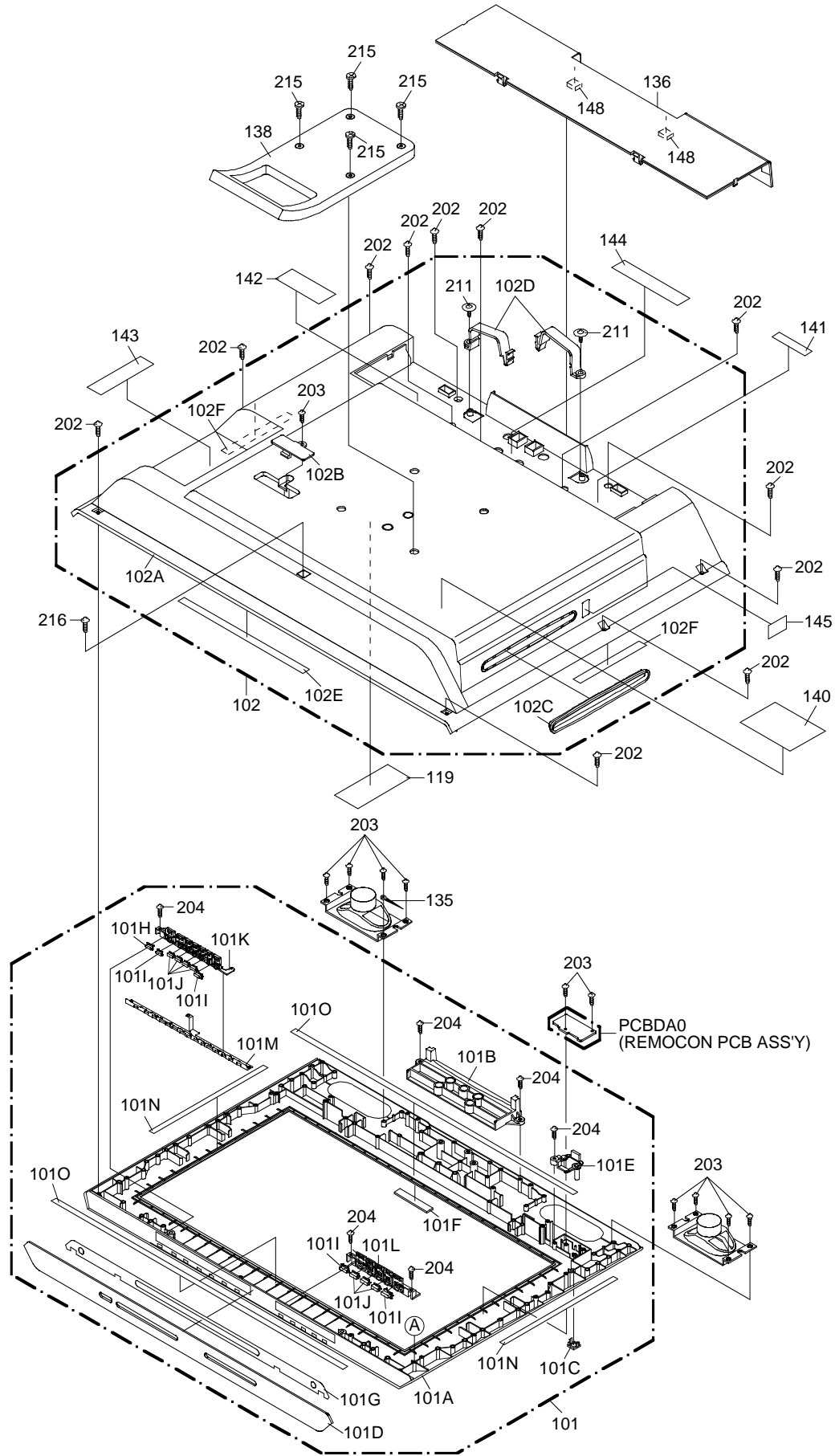

MECHANICAL EXPLODED VIEW

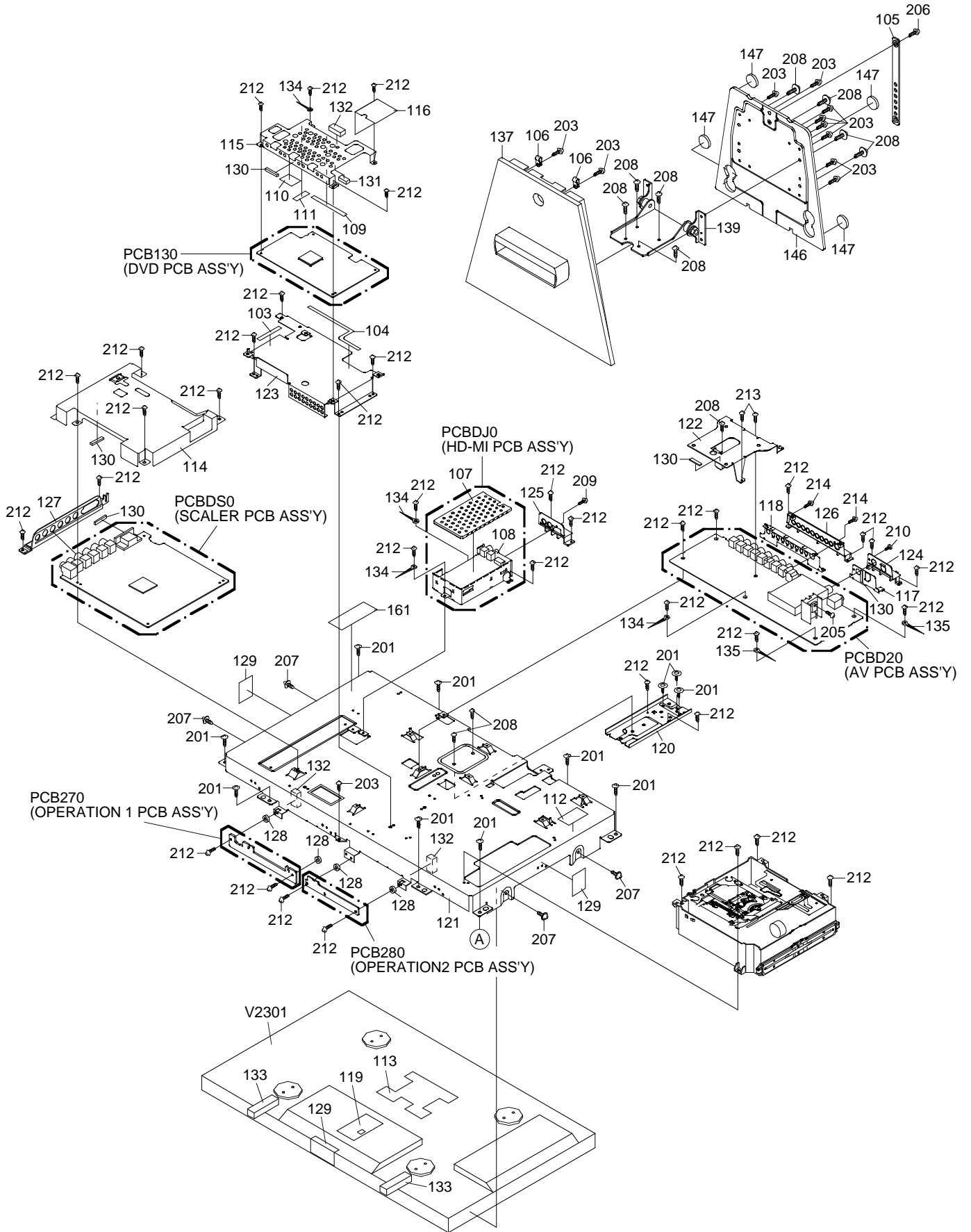

MECHANICAL EXPLODED VIEW (PACKING DIAGRAM)

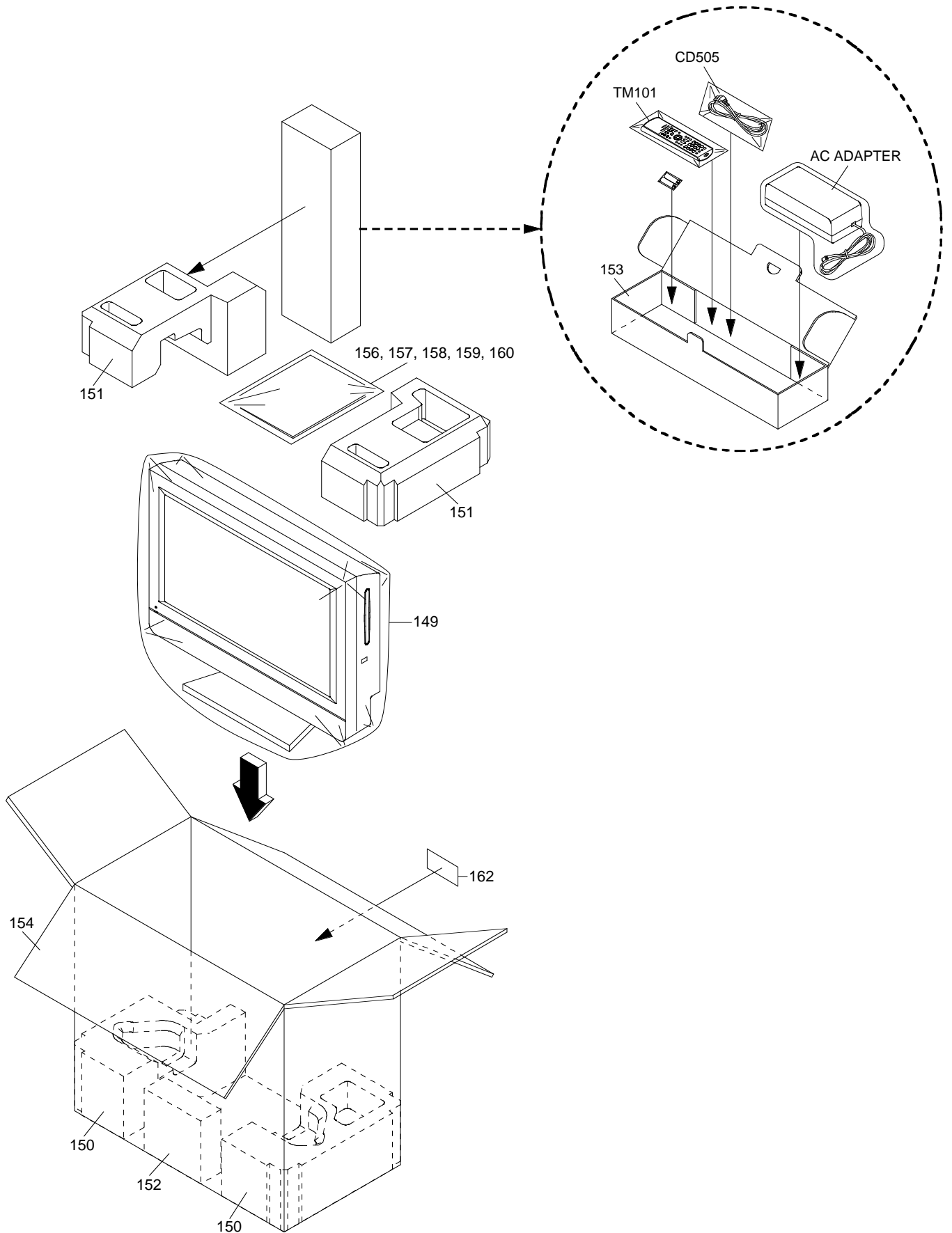

DVD DECK EXPLODED VIEW (TOP VIEW)

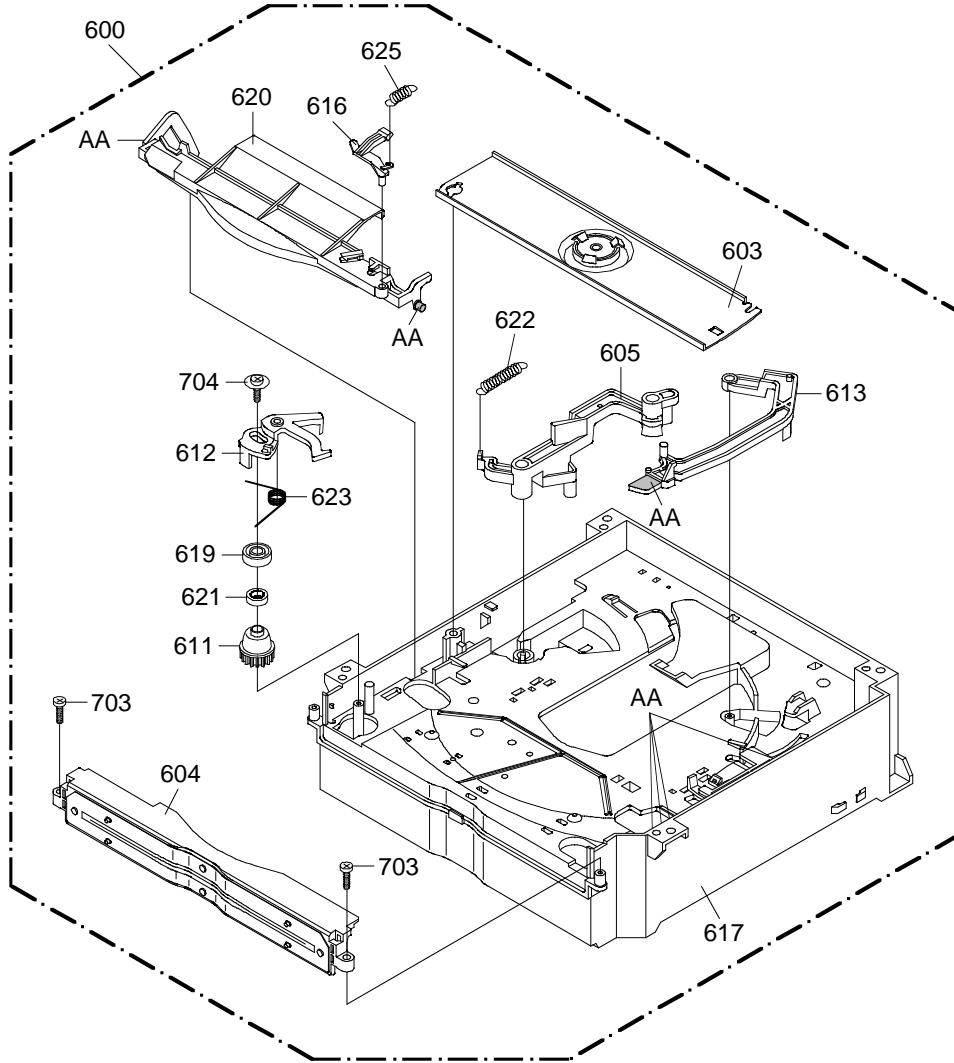

CLASS	MARK
GREASE	AA

NOTE: Applying positions AA for the grease are displayed for this section. Check if the correct grease is applied for each position.

DVD DECK EXPLODED VIEW (BOTTOM VIEW)

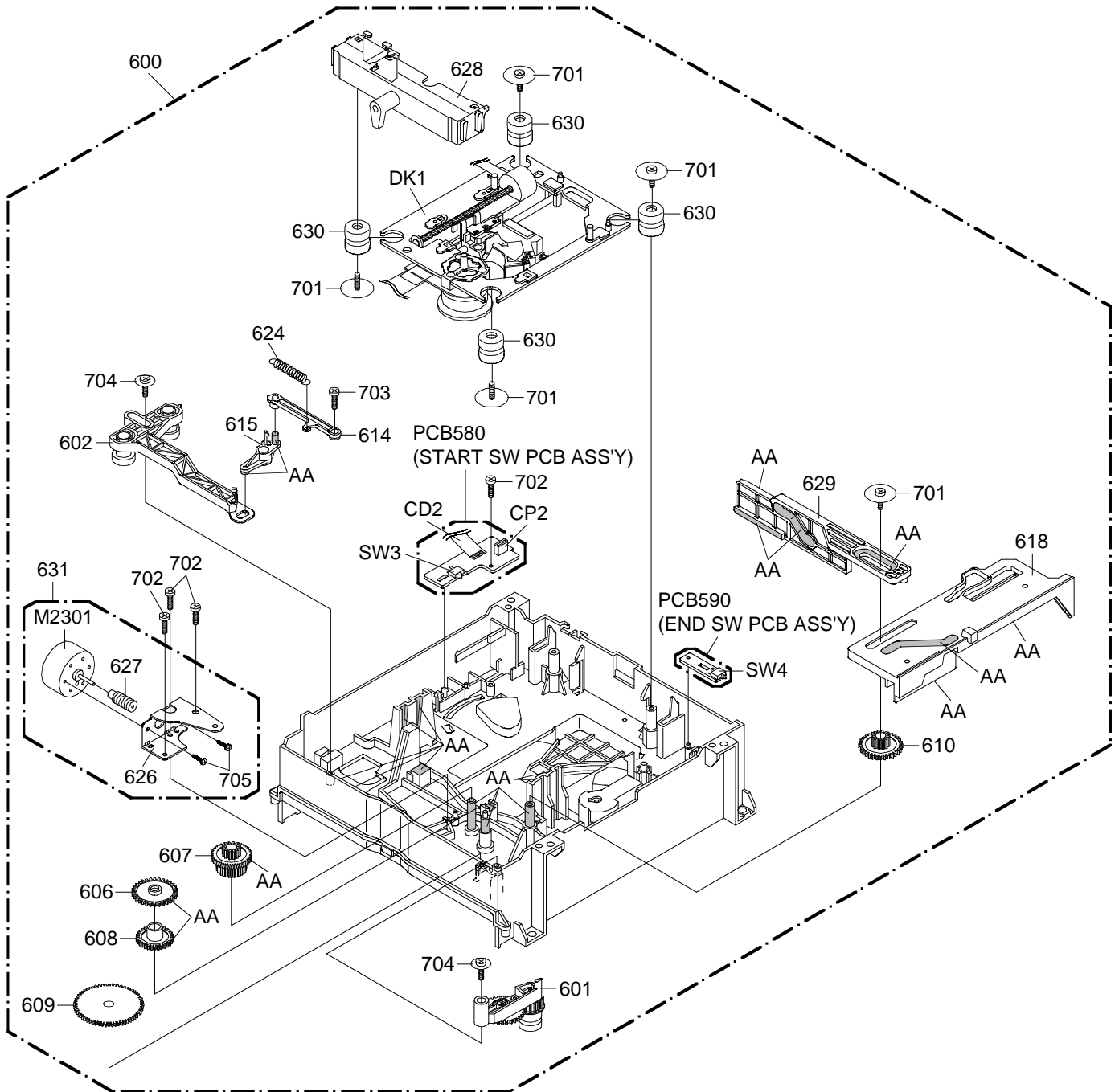

CLASS	MARK
GREASE	AA

NOTE: Applying positions AA for the grease are displayed for this section. Check if the correct grease is applied for each position.

MECHANICAL REPLACEMENT PARTS LIST

Location No.	TSB P/N	Reference No.	Description	
101	AE007843	7A7010153A	FRONT CABI ASS'Y	
101A	AE007844	701WPJ1381	CABINET,FRONT	
101B	AE007690	702WPB0077	COVER,HINGE	
101C	AE007691	711WPA0242	PLATE,FRONT	
101D	AE007692	711WPC0018	PLATE,TOP ASS'Y	
101E	AE007693	713WPA0375	GLASS,LED	
101F	AE007694	7235490068	BADGE,BRAND	
101G	AE007695	7290000158	DOUBLE FACE-TAPE	
101H	AE007696	735WPE0048	BUTTON,CAP-1	
101I	AE007697	735WPE0049	BUTTON,CAP-2	
101J	AE007698	735WPE0050	BUTTON,CAP-3	
101K	AE007699	738WPA0172	BUTTON,FRAME-TV	
101L	AE007700	738WPA0173	BUTTON,FRAME-DVD	
101M	AE007701	752WSA0516	SHIELD,BUTTON	
101N	AE005451	800WQ0A049	FELT SHEET	
101O	AE007702	800WQ00094	FELT SHEET	
102	AE007845	7A7020058A	BACK CABI ASS'Y	
102A	AE007846	702WPB0086	CABINET,BACK	
102B	AE007705	702WPB0079	COVER,CONNECTOR	
102C	AE007706	704WPE0002	SLOT,DVD	
102D	AE005455	774WPA0007	HOLDER,CORD	
102E	AE003069	800WQ0A070	FELT SHEET	
102F	AE007707	800WQ0A110	FELT SHEET	
103	AE007708	800WQ00095	FELT SHEET	
104	AE007709	800WQ00096	FELT SHEET	
105	AE007710	89900FB118	BAND	
106	AE007711	899000NK4N	CABLE CLAMPS	
107	AE004831	752WSA0413	HDMI SHIELD COVER	
108	AE007712	752WSA0511	SHIELD,BOTTOM HDMI	
109	AE005329	7250000590	SHEET,PC 1	
110	AE005330	7250000591	SHEET,PC 2	
111	AE005331	7250000592	SHEET,PC 3	
112	AE005122	726000A073	SHEET,CAUTION	
113	AE007713	735WEA0004	SHEET,CU	
114	AE007714	751WSA0017	SHIELD,LCD-PCB	
115	AE004529	752WSA0424	SHIELD,DVD	
116	AE006818	752WSA0485	SHIELD,FFC	
117	AE007715	752WSA0512	SHIELD,JACK-1	
118	AE007716	752WSA0513	SHIELD,JACK-2	
119	AE007462	753WEA0022	SHEET,CU	
120	AE007717	761WSA0264	ANGLE,HINGE	
121	AE007718	761WSA0267	COVER,LCD	
122	AE007719	761WSA0270	ANGLE,HANDLE-DVD	
123	AE007720	761WSA0271	ANGLE,PCB	
124	AE007721	771WPB0054	PLATE,JACK-1	
125	AE007722	771WPB0056	PLATE,JACK-3	
126	AE007723	771WPB0057	PLATE,JACK-2	
127	AE007724	771WPJ0004	PLATE,JACK SIDE	
128	AE001213	800WB0A008	FIBER WASHER	
129	AE007725	890MP2401A	TAPE	50x35
130	AE005521	8965TS0415	CUSHION 65TS4-2	15x50x16
131	AE005385	8965TS1015	CUSHION 65TS10-5	10x5x15
132	AE001853	8965TS1017	CUSHION 65TS10-10	17.5x20x14
133	AE007726	8965TS1060	CUSHION W10/H10/L60	
134	AD301370	899EFBA002	WIRING-CLIP	
135	BZ710039	8995034000	CORD CLIP UL CO.	
136	AE007727	702WPB0080	COVER,BACK	
137	AE007728	704WPB0012	STAND	
138	AE007729	705WPB0028	HANDLE	
139	AE007730	706JSA0013	HINGE ASS'Y	

MECHANICAL REPLACEMENT PARTS LIST

Location No.	TSB P/N	Reference No.	Description	
140	AE007847	7225490217	SHEET,RATING	
141	AE007732	7230007975	SHEET,JACK-1	
142	AE007733	7230007977	SHEET,JACK-3	
143	AE007734	7230007978	SHEET,JACK SIDE	
144	AE007735	7230007995	SHEET,JACK-2	
145	AE000156	7235630001	SHEET,DVD	
146	AE007736	761WSB0008	ANGLE,STAND	
147	AE007737	800WFA0078	CUSHION,LEG	
148	AE007738	800WFA0081	CUSHION	
149	AE002901	791WHDA001	LAMIFILM BAG	
150	AE007739	792WHA0615	PACKAGE,BOTTOM	
151	AE007740	792WHA0618	PACKAGE,TOP	
152	AE007741	792WHA0625	PACKAGE,PAD	
153	AE007742	793WCA0017	ACCESSORY BOX	
154	AE007848	793WCD1671	GIFT BOX	
155	AE007849	A5U901D975	INSTRUCTION BOOK KIT	
156	AE007850	JA4ND400	POLYBAG(RED),INSTRUCTION	
157	AE007451	J3N51617A	REGISTRATION CARD	
158	AE007627	J5S10229A	INFORMATION SHEET(USA)	
159	AE007851	J5U90121A	INSTRUCTION BOOK(E/F)	
160	AE007852	J5N00629A	INFORMATION SHEET(CND)	
161	AE005383	7220001115	SHEET,CSA WARNING	
162	AE007853	7230008028	SHEET,BAR CODE	
201	AE004847	8117540A6U	SCREW,TAP TITE(B0) TRUSS	4x16
202	AE005470	8110230A4U	SCREW,TAP TITE(P) BIND	3x14
203	AE003528	8110630A0U	SCREW,TAP TITE(P) BRAZIER	3x10
204	AE003529	811063080U	SCREW,TAP TITE(P) BRAZIER	3x8
205	AE003524	8109130A0U	SCREW,TAP TITE(B) WH7	3x10
206	AE007747	814623080U	SCREW,TAP TITE(B) BIND	3x5.7+4x2.3
207	AE007748	810A13050U	SCREW,WASHER(A)	M3x5
208	AE005338	810A140A0U	SCREW,WASHER(A)	M4x10
209	AE005214	810213080U	SCREW,PAN	M3x8
210	AE005987	810723060U	SCREW,TAP TITE(S) BIND	3x6
211	AE005472	8159130A0S	SCREW,TAPPING(B) WASHER12 PAN	3x10
212	AE005675	810923060U	SCREW,TAP TITE(B) BIND	3x6
213	AE003526	810923080U	SCREW,TAP TITE(B) BIND	3x8
214	AE007749	811023080U	SCREW,TAP TITE(P) BIND	3x8
215	AE005471	8102240A2U	SCREW,BIND	M4x12
216	AE007854	8110230A0U	SCREW,TAP TITE(P) BIND	3x10
800	AE007856	A5U901D800	AC ADAPTER CABI ASS'Y	
801	AE007751	724WNA0014	SHEET,PC	
802	AE007752	752WSA0527	SHIELD,BOTTOM	
803	AE007753	702WPA1187	CABINET,TOP	
804	AE007754	702WPA1188	CABINET,BOTTOM	
805	AE007855	7225490219	SHEET,ADAPTER	
901	AE003528	8110630A0U	SCREW,TAP TITE(P) BRAZIER	3x10

DVD DECK REPLACEMENT PARTS LIST

Location No.	TSB P/N	Reference No.	Description	
△ 600	AE006820	A5N005C650S	DVD MECHA ASS'Y	A5N005C650S
601	AE006821	92AAA0015A	ARM ROLLER ASS'Y 2	
602	AE004553	92AAA0006A	LINK,R ASS'Y	
603	AE004554	92AAA0007A	CLAMPER ASS'Y	
604	AE004555	92AAA0009A	MOUTH ASS'Y	
605	AE004556	92P100041A	ARM, DISC GUIDE	
606	AE004557	92P100044A	GEAR, MID RACK	
607	AE004558	92P100045A	GEAR, TERMINAL	
608	AE004559	92P100046A	GEAR, MID ROLLER 1	
609	AE004560	92P100047A	GEAR, MID ROLLER 2	
610	AE004561	92P100049A	GEAR, RACK	
611	AE004562	92P100050A	GEAR, ROLLER	
612	AE004563	92P100052A	LEVER, DISC L	
613	AE004564	92P100053A	LEVER, DISC R	
614	AE004565	92P100054A	LINK, L	
615	AE004566	92P100055A	LINK, MID	
616	AE004567	92P100057A	LOCKER, STOPPER	
617	AE004568	92P100058A	CHASSIS, MAIN CUT	
618	AE004569	92P100060A	RACK, LOADING	
619	AE004570	92P100062A	ROLLER, UPPER	
620	AE004571	92P100064A	STOPPER, DISC	
621	AE004572	92P200011A	RUBBER,ROLLER	
622	AE004573	92P300010A	SPRING,GUIDE ARM	
623	AE004574	92P300011A	SPRING,LEVER DISC L	
624	AE004575	92P300012A	SPRING,LINK	
625	AE004576	92P300013A	SPRING,STOPPER	
626	AE004577	92P000006A	BRACKET, LOADING MOTOR	
627	AE004578	92P100066A	WORM, LOADING	
628	AE004579	92P100051A	HOLDER, TRAVERSE UNIT	
629	AE004580	92P100061A	ROD, TRAVERSE UNIT	
630	AE004581	92P200010A	INSULATOR	
631	AE007756	A5N005C600	LOADING MOTOR ASS'Y	
701	AE006822	8110E2680U	SCREW,TAP TITE(P) WH10	M2.6x8
702	AE006823	810922060U	SCREW,TAP TITE(B) BIND	2x6
703	AE006824	810922040U	SCREW,TAP TITE(B) BIND	2x4
704	AE006825	8109I2060U	SCREW,TAP TITE(B) WH7	2x6
705	AE006826	810211718U	SCREW,PAN	M1.7x1.8
CD2	AE006406	122H092401	CORD JUMPER	2H092401
CP2	AE006411	069EV4T060	CONNECTOR PCB SIDE	04_6232_104_015_800+
DK1	AE006407	169Z00035A	DECK CD	CV-VTM101D
△ M2301	AE004589	1596998002	MOTOR	MDN3BT3ESA
PCB580	AE006827	A5N005C580	PCB ASS'Y	DED023A
PCB590	AE006828	A5N005C590	PCB ASS'Y	DED024A
SW3	AE001158	0500101036	PUSH SWITCH	ESE22MH22
SW4	AE003565	0500101037	PUSH SWITCH	ESE22MH24

ELECTRICAL REPLACEMENT PARTS LIST

Location No.	TSB P/N	Reference No.	Description
RESISTORS			
R102	AE001784	R803R9103J	RC 10K OHM 1/16W
R103	AD302345	R803R9472J	RC 4.7K OHM 1/16W
R104	AD302345	R803R9472J	RC 4.7K OHM 1/16W
R105	AD302345	R803R9472J	RC 4.7K OHM 1/16W
R106	AD302345	R803R9472J	RC 4.7K OHM 1/16W
R107	AD302345	R803R9472J	RC 4.7K OHM 1/16W
R109	AE001784	R803R9103J	RC 10K OHM 1/16W
R112	AE001783	R803R9102J	RC 1K OHM 1/16W
R114	AE001781	R803R9101J	RC 100 OHM 1/16W
R115	AE001781	R803R9101J	RC 100 OHM 1/16W
R116	AD302345	R803R9472J	RC 4.7K OHM 1/16W
R117	AD302345	R803R9472J	RC 4.7K OHM 1/16W
R118	AD302345	R803R9472J	RC 4.7K OHM 1/16W
R119	AD302345	R803R9472J	RC 4.7K OHM 1/16W
R120	AE001783	R803R9102J	RC 1K OHM 1/16W
R121	AE001783	R803R9102J	RC 1K OHM 1/16W
R122	AD302345	R803R9472J	RC 4.7K OHM 1/16W
R123	AE001783	R803R9102J	RC 1K OHM 1/16W
R126	AE001783	R803R9102J	RC 1K OHM 1/16W
R129	AD302345	R803R9472J	RC 4.7K OHM 1/16W
R132	AE001781	R803R9101J	RC 100 OHM 1/16W
R133	AE001781	R803R9101J	RC 100 OHM 1/16W
R134	AE001783	R803R9102J	RC 1K OHM 1/16W
R135	AE001784	R803R9103J	RC 10K OHM 1/16W
R136	AD302345	R803R9472J	RC 4.7K OHM 1/16W
R137	AD302345	R803R9472J	RC 4.7K OHM 1/16W
R139	AD302345	R803R9472J	RC 4.7K OHM 1/16W
R141	AE001781	R803R9101J	RC 100 OHM 1/16W
R142	AE001781	R803R9101J	RC 100 OHM 1/16W
R147	AE001781	R803R9101J	RC 100 OHM 1/16W
R148	AE001781	R803R9101J	RC 100 OHM 1/16W
R149	AE001784	R803R9103J	RC 10K OHM 1/16W
R151	AE001784	R803R9103J	RC 10K OHM 1/16W
R152	AD302345	R803R9472J	RC 4.7K OHM 1/16W
R153	AD302345	R803R9472J	RC 4.7K OHM 1/16W
R154	AD302345	R803R9472J	RC 4.7K OHM 1/16W
R155	AD302345	R803R9472J	RC 4.7K OHM 1/16W
R156	AD302345	R803R9472J	RC 4.7K OHM 1/16W
R157	AD302345	R803R9472J	RC 4.7K OHM 1/16W
R158	AE001784	R803R9103J	RC 10K OHM 1/16W
R159	AD302345	R803R9472J	RC 4.7K OHM 1/16W
R160	AE001784	R803R9103J	RC 10K OHM 1/16W
R161	AD302345	R803R9472J	RC 4.7K OHM 1/16W
R302	AE002148	R803R9183J	RC 18K OHM 1/16W
R303	AE001792	R803R9273J	RC 27K OHM 1/16W
R304	AE001784	R803R9103J	RC 10K OHM 1/16W
R305	AE001784	R803R9103J	RC 10K OHM 1/16W
△R306	BZ210204	R3X1814R7J	R,METAL OXIDE 4.7 OHM 1W
R307	AE003983	R002T42R2J	RC 2.2 OHM 1/4W
R308	AE003983	R002T42R2J	RC 2.2 OHM 1/4W
R309	AE001886	R803R9100J	RC 10 OHM 1/16W
R310	AE003983	R002T42R2J	RC 2.2 OHM 1/4W
R312	AE002148	R803R9183J	RC 18K OHM 1/16W
R313	AE001792	R803R9273J	RC 27K OHM 1/16W
R314	AE001283	R803R9470J	RC 47 OHM 1/16W
R315	AE001784	R803R9103J	RC 10K OHM 1/16W
R316	AE001784	R803R9103J	RC 10K OHM 1/16W
△R317	BZ210204	R3X1814R7J	R,METAL OXIDE 4.7 OHM 1W
R318	AE003983	R002T42R2J	RC 2.2 OHM 1/4W
R319	AE003983	R002T42R2J	RC 2.2 OHM 1/4W
R320	AE001886	R803R9100J	RC 10 OHM 1/16W
R321	AE003983	R002T42R2J	RC 2.2 OHM 1/4W
R328	AE001801	R803R9682J	RC 6.8K OHM 1/16W
R805	AE001784	R803R9103J	RC 10K OHM 1/16W
R807	AE001784	R803R9103J	RC 10K OHM 1/16W
R808	AE001784	R803R9103J	RC 10K OHM 1/16W
R809	AE001784	R803R9103J	RC 10K OHM 1/16W
R810	AE001784	R803R9103J	RC 10K OHM 1/16W
R811	AE001784	R803R9103J	RC 10K OHM 1/16W
R812	AE001784	R803R9103J	RC 10K OHM 1/16W
R813	AE001784	R803R9103J	RC 10K OHM 1/16W

ELECTRICAL REPLACEMENT PARTS LIST

Location No.	TSB P/N	Reference No.	Description
RESISTORS			
R814	AE001784	R803R9103J	RC 10K OHM 1/16W
R815	AE001784	R803R9103J	RC 10K OHM 1/16W
R816	AE001784	R803R9103J	RC 10K OHM 1/16W
R817	AE001784	R803R9103J	RC 10K OHM 1/16W
R818	AE001784	R803R9103J	RC 10K OHM 1/16W
R819	AE001784	R803R9103J	RC 10K OHM 1/16W
R820	AE001784	R803R9103J	RC 10K OHM 1/16W
R821	AE001784	R803R9103J	RC 10K OHM 1/16W
R822	AE001784	R803R9103J	RC 10K OHM 1/16W
R823	AE001784	R803R9103J	RC 10K OHM 1/16W
R825	AE001887	R803R9105J	RC 1M OHM 1/16W
R826	AE001784	R803R9103J	RC 10K OHM 1/16W
R828	AE001784	R803R9103J	RC 10K OHM 1/16W
R830	79091139	R803R9151J	RC 150 OHM 1/16W
R831	AE001784	R803R9103J	RC 10K OHM 1/16W
R833	AE001283	R803R9470J	RC 47 OHM 1/16W
R834	AE001784	R803R9103J	RC 10K OHM 1/16W
R835	AE001784	R803R9103J	RC 10K OHM 1/16W
R836	AE001783	R803R9102J	RC 1K OHM 1/16W
R840	AE001890	R803R9221J	RC 220 OHM 1/16W
R2102	AE001783	R803R9102J	RC 1K OHM 1/16W
R2103	AE001805	R803R9822J	RC 8.2K OHM 1/16W
R2104	AE001781	R803R9101J	RC 100 OHM 1/16W
R2105	AE001781	R803R9101J	RC 100 OHM 1/16W
R2106	AE001794	R803R9330J	RC 33 OHM 1/16W
R2107	AE001781	R803R9101J	RC 100 OHM 1/16W
R2108	AE001783	R803R9102J	RC 1K OHM 1/16W
R2109	AE001890	R803R9221J	RC 220 OHM 1/16W
R2110	AE001781	R803R9101J	RC 100 OHM 1/16W
R2111	AE001796	R803R9471J	RC 470 OHM 1/16W
R2112	AE001783	R803R9102J	RC 1K OHM 1/16W
R2202	AE000849	R803R9152J	RC 1.5K OHM 1/16W
R2203	AE002151	R803R9391J	RC 390 OHM 1/16W
R2204	AE001783	R803R9102J	RC 1K OHM 1/16W
R2206	AE002154	R803R9821J	RC 820 OHM 1/16W
R2212	AE001801	R803R9682J	RC 6.8K OHM 1/16W
R2213	AE002532	R803R9272J	RC 2.7K OHM 1/16W
R2251	AE002154	R803R9821J	RC 820 OHM 1/16W
R2252	AE001783	R803R9102J	RC 1K OHM 1/16W
R2253	AE000849	R803R9152J	RC 1.5K OHM 1/16W
R2254	AE002532	R803R9272J	RC 2.7K OHM 1/16W
R2255	AE001801	R803R9682J	RC 6.8K OHM 1/16W
R2301	AE001784	R803R9103J	RC 10K OHM 1/16W
R2302	AE001781	R803R9101J	RC 100 OHM 1/16W
R2303	AE001891	R803R9223J	RC 22K OHM 1/16W
R2304	AE005096	R803R9512J	RC 5.1K OHM 1/16W
R2306	AE001886	R803R9100J	RC 10 OHM 1/16W
R2307	AE001886	R803R9100J	RC 10 OHM 1/16W
R2309	AE001784	R803R9103J	RC 10K OHM 1/16W
R2310	79091264	R803R94R7J	RC 4.7 OHM 1/16W
R2312	AE001784	R803R9103J	RC 10K OHM 1/16W
R2314	AE001793	R803R92R2J	RC 2.2 OHM 1/16W
R2315	AE002145	R803R9153J	RC 15K OHM 1/16W
R2316	AE002907	R803R9562F	RC 5.6K OHM 1/16W
R2319	AE001784	R803R9103J	RC 10K OHM 1/16W
R2320	AE001785	R803R9104J	RC 100K OHM 1/16W
R2321	AE001886	R803R9100J	RC 10 OHM 1/16W
R2322	AE001886	R803R9100J	RC 10 OHM 1/16W
R2323	AE001886	R803R9100J	RC 10 OHM 1/16W
R2324	AE001886	R803R9100J	RC 10 OHM 1/16W
R2325	79091264	R803R94R7J	RC 4.7 OHM 1/16W
R2326	79091264	R803R94R7J	RC 4.7 OHM 1/16W
R2327	79091264	R803R94R7J	RC 4.7 OHM 1/16W
R2330	AE001784	R803R9103J	RC 10K OHM 1/16W
R2331	AE002145	R803R9153J	RC 15K OHM 1/16W
R2334	AE001781	R803R9101J	RC 100 OHM 1/16W
R2335	AE002907	R803R9562F	RC 5.6K OHM 1/16W
R2337	AE001782	R803R9102F	RC 1K OHM 1/16W
R2338	AE001782	R803R9102F	RC 1K OHM 1/16W
R2346	AE002907	R803R9562F	RC 5.6K OHM 1/16W
R2347	AE002907	R803R9562F	RC 5.6K OHM 1/16W

ELECTRICAL REPLACEMENT PARTS LIST

Location No.	TSB P/N	Reference No.	Description
RESISTORS			
R2350	AE002907	R803R9562F	RC 5.6K OHM 1/16W
R2351	AE002907	R803R9562F	RC 5.6K OHM 1/16W
R2601	AD302345	R803R9472J	RC 4.7K OHM 1/16W
R2602	AE000850	R803R9185J	RC 1.8M OHM 1/16W
R2603	AE000847	R803R9133F	RC 13K OHM 1/16W
R2604	AE000852	R803R9273F	RC 27K OHM 1/16W
R2605	AE000845	R803R9103F	RC 10K OHM 1/16W
R2607	AE001787	R803R9122J	RC 1.2K OHM 1/16W
R2608	AE001787	R803R9122J	RC 1.2K OHM 1/16W
R2609	AE001787	R803R9122J	RC 1.2K OHM 1/16W
R2610	AE000853	R803R9512F	RC 5.1K OHM 1/16W
R2611	AD302345	R803R9472J	RC 4.7K OHM 1/16W
R2612	AD302345	R803R9472J	RC 4.7K OHM 1/16W
R2613	AD302345	R803R9472J	RC 4.7K OHM 1/16W
R2614	AE000846	R803R9123F	RC 12K OHM 1/16W
R2615	AE001886	R803R9100J	RC 10 OHM 1/16W
R2616	AE001783	R803R9102J	RC 1K OHM 1/16W
R2617	AE001783	R803R9102J	RC 1K OHM 1/16W
R2618	79091397	R803R9180J	RC 18 OHM 1/16W
R2619	AE001781	R803R9101J	RC 100 OHM 1/16W
R2620	AD302345	R803R9472J	RC 4.7K OHM 1/16W
R2621	AE001781	R803R9101J	RC 100 OHM 1/16W
R2622	AD302345	R803R9472J	RC 4.7K OHM 1/16W
R2623	AD302345	R803R9472J	RC 4.7K OHM 1/16W
R2624	AD302345	R803R9472J	RC 4.7K OHM 1/16W
R2626	AE002151	R803R9391J	RC 390 OHM 1/16W
R2633	AD302345	R803R9472J	RC 4.7K OHM 1/16W
R2634	AE001887	R803R9105J	RC 1M OHM 1/16W
R2635	AE001887	R803R9105J	RC 1M OHM 1/16W
R2643	AE001783	R803R9102J	RC 1K OHM 1/16W
R2644	AE001790	R803R9222J	RC 2.2K OHM 1/16W
R2645	AE001783	R803R9102J	RC 1K OHM 1/16W
R2646	AE001790	R803R9222J	RC 2.2K OHM 1/16W
R2647	AD302345	R803R9472J	RC 4.7K OHM 1/16W
R2648	AE000848	R803R9133J	RC 13K OHM 1/16W
R2654	79091397	R803R9180J	RC 18 OHM 1/16W
R3001	AE001784	R803R9103J	RC 10K OHM 1/16W
R3002	AE001799	R803R9562J	RC 5.6K OHM 1/16W
R3003	AE001783	R803R9102J	RC 1K OHM 1/16W
R3004	AE000845	R803R9103F	RC 10K OHM 1/16W
R3005	AE000845	R803R9103F	RC 10K OHM 1/16W
R3006	AD302291	R803R9683J	RC 68K OHM 1/16W
R3007	AE001898	R803R9563J	RC 56K OHM 1/16W
R3008	AE002908	R803R9183F	RC 18K OHM 1/16W
R3009	AE000845	R803R9103F	RC 10K OHM 1/16W
R3010	AE000845	R803R9103F	RC 10K OHM 1/16W
R3011	AD302291	R803R9683J	RC 68K OHM 1/16W
R3012	AE001898	R803R9563J	RC 56K OHM 1/16W
R3013	AE002152	R803R9561J	RC 560 OHM 1/16W
R3014	AE001799	R803R9562J	RC 5.6K OHM 1/16W
R3015	AE001886	R803R9100J	RC 10 OHM 1/16W
R3016	AE001886	R803R9100J	RC 10 OHM 1/16W
R3018	AE006856	R803R9752F	RC 7.5K OHM 1/16W
R3019	AE005088	R803R9182F	RC 1.8K OHM 1/16W
R3020	AE002152	R803R9561J	RC 560 OHM 1/16W
R3021	AE001799	R803R9562J	RC 5.6K OHM 1/16W
R3022	AE001886	R803R9100J	RC 10 OHM 1/16W
R3023	AE001886	R803R9100J	RC 10 OHM 1/16W
R3024	AE005090	R803R9221F	RC 220 OHM 1/16W
R3025	AE005092	R803R9272F	RC 2.7K OHM 1/16W
R3026	AE005088	R803R9182F	RC 1.8K OHM 1/16W
R3027	AE001897	R803R9511F	RC 510 OHM 1/16W
R3029	AE001782	R803R9102F	RC 1K OHM 1/16W
R3209	AE001784	R803R9103J	RC 10K OHM 1/16W
R3211	AE002907	R803R9562F	RC 5.6K OHM 1/16W
R3212	AE001795	R803R9332F	RC 3.3K OHM 1/16W
R3216	AE002152	R803R9561J	RC 560 OHM 1/16W
R3217	AE002152	R803R9561J	RC 560 OHM 1/16W
R3220	AE001784	R803R9103J	RC 10K OHM 1/16W
R3221	AE004090	R803R9471F	RC 470 OHM 1/16W
R3222	AE001782	R803R9102F	RC 1K OHM 1/16W

ELECTRICAL REPLACEMENT PARTS LIST

Location No.	TSB P/N	Reference No.	Description
RESISTORS			
R3223	AE001891	R803R9223J	RC 22K OHM 1/16W
R3224	AE001783	R803R9102J	RC 1K OHM 1/16W
R3225	AE001891	R803R9223J	RC 22K OHM 1/16W
R3226	AE001783	R803R9102J	RC 1K OHM 1/16W
R3227	AE001783	R803R9102J	RC 1K OHM 1/16W
R3228	AE001805	R803R9822J	RC 8.2K OHM 1/16W
R3229	AE001783	R803R9102J	RC 1K OHM 1/16W
R3601	AE001886	R803R9100J	RC 10 OHM 1/16W
R3605	AE001797	R803R9473J	RC 47K OHM 1/16W
R3606	AE001283	R803R9470J	RC 47 OHM 1/16W
R3607	AE001283	R803R9470J	RC 47 OHM 1/16W
R3608	AE001896	R803R9474J	RC 470K OHM 1/16W
R3609	AE001896	R803R9474J	RC 470K OHM 1/16W
R3610	AE002151	R803R9391J	RC 390 OHM 1/16W
R3611	AE001794	R803R9330J	RC 33 OHM 1/16W
R3613	AE001784	R803R9103J	RC 10K OHM 1/16W
R3614	AE001784	R803R9103J	RC 10K OHM 1/16W
R3615	AE001785	R803R9104J	RC 100K OHM 1/16W
R3616	AE001785	R803R9104J	RC 100K OHM 1/16W
R3617	AE001794	R803R9330J	RC 33 OHM 1/16W
R3618	AE001783	R803R9102J	RC 1K OHM 1/16W
R3619	AD302345	R803R9472J	RC 4.7K OHM 1/16W
R3620	AD302345	R803R9472J	RC 4.7K OHM 1/16W
R3621	AE001783	R803R9102J	RC 1K OHM 1/16W
R3622	AE002153	R803R9820F	RC 82 OHM 1/16W
R3623	AD302345	R803R9472J	RC 4.7K OHM 1/16W
R3624	AE001895	R803R9392J	RC 3.9K OHM 1/16W
R3625	AE001794	R803R9330J	RC 33 OHM 1/16W
R3626	AE001794	R803R9330J	RC 33 OHM 1/16W
R3627	AE001794	R803R9330J	RC 33 OHM 1/16W
R3628	AD302345	R803R9472J	RC 4.7K OHM 1/16W
R3629	AE001798	R803R9560J	RC 56 OHM 1/16W
R3630	AE001790	R803R9222J	RC 2.2K OHM 1/16W
R3631	AD302345	R803R9472J	RC 4.7K OHM 1/16W
R3632	AD302345	R803R9472J	RC 4.7K OHM 1/16W
R3633	AE001899	R803R9750F	RC 75 OHM 1/16W
R3634	AE001899	R803R9750F	RC 75 OHM 1/16W
R3635	AE001899	R803R9750F	RC 75 OHM 1/16W
R3636	AD302345	R803R9472J	RC 4.7K OHM 1/16W
R3637	AD302345	R803R9472J	RC 4.7K OHM 1/16W
R3638	AD302345	R803R9472J	RC 4.7K OHM 1/16W
R3639	AD302345	R803R9472J	RC 4.7K OHM 1/16W
R3640	AD302345	R803R9472J	RC 4.7K OHM 1/16W
R3641	AE001790	R803R9222J	RC 2.2K OHM 1/16W
R3642	AE001783	R803R9102J	RC 1K OHM 1/16W
R3643	AD302345	R803R9472J	RC 4.7K OHM 1/16W
R3644	AD302345	R803R9472J	RC 4.7K OHM 1/16W
R3645	AD302345	R803R9472J	RC 4.7K OHM 1/16W
R3647	AE001784	R803R9103J	RC 10K OHM 1/16W
R3648	AE001794	R803R9330J	RC 33 OHM 1/16W
R3649	AD302345	R803R9472J	RC 4.7K OHM 1/16W
R3650	AE001784	R803R9103J	RC 10K OHM 1/16W
R3651	AE005767	R803R9101F	RC 100 OHM 1/16W
R3652	AD302345	R803R9472J	RC 4.7K OHM 1/16W
R3653	AD302345	R803R9472J	RC 4.7K OHM 1/16W
R3654	AD302345	R803R9472J	RC 4.7K OHM 1/16W
R3655	AE001784	R803R9103J	RC 10K OHM 1/16W
R3656	AE001784	R803R9103J	RC 10K OHM 1/16W
R3657	AE001784	R803R9103J	RC 10K OHM 1/16W
R3658	AE001784	R803R9103J	RC 10K OHM 1/16W
R3659	AE001805	R803R9822J	RC 8.2K OHM 1/16W
R3660	AE001805	R803R9822J	RC 8.2K OHM 1/16W
R3661	AE001784	R803R9103J	RC 10K OHM 1/16W
R3662	AE001784	R803R9103J	RC 10K OHM 1/16W
R3663	AE001783	R803R9102J	RC 1K OHM 1/16W
R3664	AE001783	R803R9102J	RC 1K OHM 1/16W
R3665	AE001781	R803R9101J	RC 100 OHM 1/16W
R3666	AE001781	R803R9101J	RC 100 OHM 1/16W
R3667	AE001783	R803R9102J	RC 1K OHM 1/16W
R3668	AE001783	R803R9102J	RC 1K OHM 1/16W
R3669	AE001794	R803R9330J	RC 33 OHM 1/16W

ELECTRICAL REPLACEMENT PARTS LIST

Location No.	TSB P/N	Reference No.	Description
RESISTORS			
R3674	AE001799	R803R9562J	RC 5.6K OHM 1/16W
R3675	AE001799	R803R9562J	RC 5.6K OHM 1/16W
R3676	79091400	R803R9393J	RC 39K OHM 1/16W
R3677	79091400	R803R9393J	RC 39K OHM 1/16W
R3678	AD302345	R803R9472J	RC 4.7K OHM 1/16W
R3679	AE001785	R803R9104J	RC 100K OHM 1/16W
R3680	AE002871	R803R9224J	RC 220K OHM 1/16W
R3681	AE001790	R803R9222J	RC 2.2K OHM 1/16W
R3682	AE001781	R803R9101J	RC 100 OHM 1/16W
R3683	AE001781	R803R9101J	RC 100 OHM 1/16W
R3684	AE001781	R803R9101J	RC 100 OHM 1/16W
R3801	AE001891	R803R9223J	RC 22K OHM 1/16W
R3802	AE002150	R803R9333J	RC 33K OHM 1/16W
R3803	AE002145	R803R9153J	RC 15K OHM 1/16W
R3804	AE001784	R803R9103J	RC 10K OHM 1/16W
R3805	AE002530	R803R9124J	RC 120K OHM 1/16W
R3806	AE002145	R803R9153J	RC 15K OHM 1/16W
R3807	AE002150	R803R9333J	RC 33K OHM 1/16W
R3808	AE001783	R803R9102J	RC 1K OHM 1/16W
R3809	BZ210124	R002T4122J	RC 1.2K OHM 1/4W
R3810	AE001784	R803R9103J	RC 10K OHM 1/16W
△R3811	BZ210059	R3X1812R2J	R,METAL OXIDE 2.2 OHM 1W
R3812	AE002150	R803R9333J	RC 33K OHM 1/16W
R3813	AE001891	R803R9223J	RC 22K OHM 1/16W
R3814	AE001891	R803R9223J	RC 22K OHM 1/16W
R3816	AE007833	R81LR7S47F	RC 0.047 OHM 1/10W
R3817	AE007833	R81LR7S47F	RC 0.047 OHM 1/10W
R3818	AE002150	R803R9333J	RC 33K OHM 1/16W
R3819	AE001782	R803R9102F	RC 1K OHM 1/16W
R3820	AE007831	R803R9152F	RC 1.5K OHM 1/16W
R3821	AE007833	R81LR7S47F	RC 0.047 OHM 1/10W
R3822	AE007833	R81LR7S47F	RC 0.047 OHM 1/10W
R3823	AE007833	R81LR7S47F	RC 0.047 OHM 1/10W
R3824	AE005087	R803R9181F	RC 180 OHM 1/16W
R3825	AE000845	R803R9103F	RC 10K OHM 1/16W
R3826	AE002908	R803R9183F	RC 18K OHM 1/16W
R3827	AE001891	R803R9223J	RC 22K OHM 1/16W
R3828	AE002876	R803R9472F	RC 4.7K OHM 1/16W
R3829	AE001893	R803R9332J	RC 3.3K OHM 1/16W
R3830	AE001891	R803R9223J	RC 22K OHM 1/16W
R3831	AE001891	R803R9223J	RC 22K OHM 1/16W
R3832	AD302345	R803R9472J	RC 4.7K OHM 1/16W
R3833	AE002150	R803R9333J	RC 33K OHM 1/16W
R3834	AE007833	R81LR7S47F	RC 0.047 OHM 1/10W
R3835	AE007833	R81LR7S47F	RC 0.047 OHM 1/10W
R3836	AE001784	R803R9103J	RC 10K OHM 1/16W
R3837	AE001782	R803R9102F	RC 1K OHM 1/16W
R3839	AE007832	R803R9302F	RC 3K OHM 1/16W
R3840	AE001801	R803R9682J	RC 6.8K OHM 1/16W
R3841	AE001893	R803R9332J	RC 3.3K OHM 1/16W
R3842	AE005087	R803R9181F	RC 180 OHM 1/16W
R3843	AE001891	R803R9223J	RC 22K OHM 1/16W
R3844	AE001792	R803R9273J	RC 27K OHM 1/16W
R3845	AE001784	R803R9103J	RC 10K OHM 1/16W
R3847	AE001886	R803R9100J	RC 10 OHM 1/16W
R3848	AE001886	R803R9100J	RC 10 OHM 1/16W
R3849	BZ210060	R002T4332J	RC 3.3K OHM 1/4W
R3851	AE001783	R803R9102J	RC 1K OHM 1/16W
R3852	AE001783	R803R9102J	RC 1K OHM 1/16W
R3853	AE001801	R803R9682J	RC 6.8K OHM 1/16W
R3854	AE001891	R803R9223J	RC 22K OHM 1/16W
R3855	AE001797	R803R9473J	RC 47K OHM 1/16W
R3856	AE001797	R803R9473J	RC 47K OHM 1/16W
R3857	AE001784	R803R9103J	RC 10K OHM 1/16W
R3858	AD302345	R803R9472J	RC 4.7K OHM 1/16W
R3859	AD302345	R803R9472J	RC 4.7K OHM 1/16W
R3862	AE001891	R803R9223J	RC 22K OHM 1/16W
R3863	AE001785	R803R9104J	RC 100K OHM 1/16W
R3864	AE001784	R803R9103J	RC 10K OHM 1/16W
R3865	AD302345	R803R9472J	RC 4.7K OHM 1/16W
R3866	AD302345	R803R9472J	RC 4.7K OHM 1/16W

ELECTRICAL REPLACEMENT PARTS LIST

Location No.	TSB P/N	Reference No.	Description
RESISTORS			
R3867	AE001893	R803R9332J	RC 3.3K OHM 1/16W
R3868	AD302345	R803R9472J	RC 4.7K OHM 1/16W
R3869	AD302345	R803R9472J	RC 4.7K OHM 1/16W
R3870	AE001893	R803R9332J	RC 3.3K OHM 1/16W
R3871	AE001893	R803R9332J	RC 3.3K OHM 1/16W
R3872	AE001893	R803R9332J	RC 3.3K OHM 1/16W
R4001	AE001894	R803R9391F	RC 390 OHM 1/16W
R4002	AE001899	R803R9750F	RC 75 OHM 1/16W
R4003	AE001899	R803R9750F	RC 75 OHM 1/16W
R4004	AE001899	R803R9750F	RC 75 OHM 1/16W
R4005	AE001899	R803R9750F	RC 75 OHM 1/16W
R4008	AE001781	R803R9101J	RC 100 OHM 1/16W
R4011	AD302345	R803R9472J	RC 4.7K OHM 1/16W
R4012	AE001887	R803R9105J	RC 1M OHM 1/16W
R4013	AE001283	R803R9470J	RC 47 OHM 1/16W
R4014	AD302345	R803R9472J	RC 4.7K OHM 1/16W
R4018	AD302345	R803R9472J	RC 4.7K OHM 1/16W
R4019	AE001794	R803R9330J	RC 33 OHM 1/16W
R4020	AE001794	R803R9330J	RC 33 OHM 1/16W
R4021	AE001794	R803R9330J	RC 33 OHM 1/16W
R4022	AE002872	R803R9271J	RC 270 OHM 1/16W
R4023	AD302345	R803R9472J	RC 4.7K OHM 1/16W
R4024	AD302345	R803R9472J	RC 4.7K OHM 1/16W
R4025	AE002872	R803R9271J	RC 270 OHM 1/16W
R4026	AE001890	R803R9221J	RC 220 OHM 1/16W
R4027	AE001890	R803R9221J	RC 220 OHM 1/16W
R4031	AD302345	R803R9472J	RC 4.7K OHM 1/16W
R4032	AE001891	R803R9223J	RC 22K OHM 1/16W
R4033	AE001793	R803R92R2J	RC 2.2 OHM 1/16W
R4034	AE001793	R803R92R2J	RC 2.2 OHM 1/16W
R4035	AD302345	R803R9472J	RC 4.7K OHM 1/16W
R4036	AD302345	R803R9472J	RC 4.7K OHM 1/16W
R4037	AD302345	R803R9472J	RC 4.7K OHM 1/16W
R4038	AD302345	R803R9472J	RC 4.7K OHM 1/16W
R4039	AD302345	R803R9472J	RC 4.7K OHM 1/16W
R4040	AD302345	R803R9472J	RC 4.7K OHM 1/16W
R4041	AD302345	R803R9472J	RC 4.7K OHM 1/16W
R4042	AE001781	R803R9101J	RC 100 OHM 1/16W
R4043	AE001784	R803R9103J	RC 10K OHM 1/16W
R4044	AE001891	R803R9223J	RC 22K OHM 1/16W
R4045	AE001783	R803R9102J	RC 1K OHM 1/16W
R4046	AD302345	R803R9472J	RC 4.7K OHM 1/16W
R4048	AE001797	R803R9473J	RC 47K OHM 1/16W
R4049	AD302345	R803R9472J	RC 4.7K OHM 1/16W
R4050	AD302345	R803R9472J	RC 4.7K OHM 1/16W
R4051	AD302345	R803R9472J	RC 4.7K OHM 1/16W
R4052	AD302345	R803R9472J	RC 4.7K OHM 1/16W
R4053	AE001783	R803R9102J	RC 1K OHM 1/16W
R4054	AE001783	R803R9102J	RC 1K OHM 1/16W
R4056	AE001892	R803R9331J	RC 330 OHM 1/16W
R4057	AE001892	R803R9331J	RC 330 OHM 1/16W
R4058	AE001890	R803R9221J	RC 220 OHM 1/16W
R4059	AE001781	R803R9101J	RC 100 OHM 1/16W
R4060	AE001891	R803R9223J	RC 22K OHM 1/16W
R4061	AE001784	R803R9103J	RC 10K OHM 1/16W
R4064	AE001781	R803R9101J	RC 100 OHM 1/16W
R4073	AE001892	R803R9331J	RC 330 OHM 1/16W
R4211	AE001801	R803R9682J	RC 6.8K OHM 1/16W
R4301	AE001784	R803R9103J	RC 10K OHM 1/16W
R4305	AE001803	R803R9750J	RC 75 OHM 1/16W
R4306	AE001803	R803R9750J	RC 75 OHM 1/16W
R4307	AE001784	R803R9103J	RC 10K OHM 1/16W
R4308	AE001803	R803R9750J	RC 75 OHM 1/16W
R4309	AE001784	R803R9103J	RC 10K OHM 1/16W
R4310	AE001803	R803R9750J	RC 75 OHM 1/16W
R4311	AE001801	R803R9682J	RC 6.8K OHM 1/16W
R4312	AE001801	R803R9682J	RC 6.8K OHM 1/16W
R4313	AE001801	R803R9682J	RC 6.8K OHM 1/16W
R4314	AE001801	R803R9682J	RC 6.8K OHM 1/16W
R4315	AE001784	R803R9103J	RC 10K OHM 1/16W
R4316	AE001784	R803R9103J	RC 10K OHM 1/16W

ELECTRICAL REPLACEMENT PARTS LIST

Location No.	TSB P/N	Reference No.	Description
RESISTORS			
R4317	AE005089	R803R9184J	180K OHM 1/16W
R4318	AE002871	R803R9224J	220K OHM 1/16W
R4319	AE005089	R803R9184J	180K OHM 1/16W
R4320	AE002871	R803R9224J	220K OHM 1/16W
R4322	AE001893	R803R9332J	3.3K OHM 1/16W
R4324	AE001893	R803R9332J	3.3K OHM 1/16W
R4325	AE001784	R803R9103J	10K OHM 1/16W
R4326	AE005089	R803R9184J	180K OHM 1/16W
R4327	AE002871	R803R9224J	220K OHM 1/16W
R4328	AE005089	R803R9184J	180K OHM 1/16W
R4329	AE002871	R803R9224J	220K OHM 1/16W
R4331	AE001893	R803R9332J	3.3K OHM 1/16W
R4333	AE001893	R803R9332J	3.3K OHM 1/16W
R4334	AD302291	R803R9683J	68K OHM 1/16W
R4335	AD302345	R803R9472J	4.7K OHM 1/16W
R4336	AD302291	R803R9683J	68K OHM 1/16W
R4337	AE001803	R803R9750J	75 OHM 1/16W
R4338	AE001803	R803R9750J	75 OHM 1/16W
R4339	AE001893	R803R9332J	3.3K OHM 1/16W
R4340	AE001784	R803R9103J	10K OHM 1/16W
R4341	AE001784	R803R9103J	10K OHM 1/16W
R4342	AE001781	R803R9101J	100 OHM 1/16W
R4343	AE001781	R803R9101J	100 OHM 1/16W
R4344	AE001783	R803R9102J	1K OHM 1/16W
R4345	AE001798	R803R9560J	56 OHM 1/16W
R4346	AE001783	R803R9102J	1K OHM 1/16W
R4347	AE001784	R803R9103J	10K OHM 1/16W
R4348	AE001784	R803R9103J	10K OHM 1/16W
R4349	AE001788	R803R9123J	12K OHM 1/16W
R4350	AE001788	R803R9123J	12K OHM 1/16W
R4351	AE001784	R803R9103J	10K OHM 1/16W
R4352	AE001797	R803R9473J	47K OHM 1/16W
R4353	AE001784	R803R9103J	10K OHM 1/16W
R4354	AE001784	R803R9103J	10K OHM 1/16W
R4355	AE001797	R803R9473J	47K OHM 1/16W
R4356	AE001785	R803R9104J	100K OHM 1/16W
R4357	AE001785	R803R9104J	100K OHM 1/16W
R4358	AE001784	R803R9103J	10K OHM 1/16W
R4361	AE001784	R803R9103J	10K OHM 1/16W
R4362	AE001784	R803R9103J	10K OHM 1/16W
R4363	AE001803	R803R9750J	75 OHM 1/16W
R4401	AE002146	R803R9154J	150K OHM 1/16W
R4403	AE001797	R803R9473J	47K OHM 1/16W
R4406	AE001803	R803R9750J	75 OHM 1/16W
R4407	AE001803	R803R9750J	75 OHM 1/16W
R4408	AE001803	R803R9750J	75 OHM 1/16W
R4409	AE001801	R803R9682J	6.8K OHM 1/16W
R4410	AE001801	R803R9682J	6.8K OHM 1/16W
R4411	AE001801	R803R9682J	6.8K OHM 1/16W
R4412	AE001781	R803R9101J	100 OHM 1/16W
R4413	AE001781	R803R9101J	100 OHM 1/16W
R4415	AE001785	R803R9104J	100K OHM 1/16W
R4416	AE001798	R803R9560J	56 OHM 1/16W
R4419	AE005089	R803R9184J	180K OHM 1/16W
R4420	AE002871	R803R9224J	220K OHM 1/16W
R4421	AE005089	R803R9184J	180K OHM 1/16W
R4422	AE002871	R803R9224J	220K OHM 1/16W
R4423	AE001798	R803R9560J	56 OHM 1/16W
R4426	AE001893	R803R9332J	3.3K OHM 1/16W
R4428	AE001893	R803R9332J	3.3K OHM 1/16W
R4430	AE005089	R803R9184J	180K OHM 1/16W
R4431	AE002871	R803R9224J	220K OHM 1/16W
R4432	AE005089	R803R9184J	180K OHM 1/16W
R4433	AE002871	R803R9224J	220K OHM 1/16W
R4435	AE001893	R803R9332J	3.3K OHM 1/16W
R4437	AE001893	R803R9332J	3.3K OHM 1/16W
R4438	79091390	R002T2101J	100 OHM 1/2W
R4439	79091390	R002T2101J	100 OHM 1/2W
R4440	AE001798	R803R9560J	56 OHM 1/16W
R4441	AE001803	R803R9750J	75 OHM 1/16W
R4442	AE001803	R803R9750J	75 OHM 1/16W

ELECTRICAL REPLACEMENT PARTS LIST

Location No.	TSB P/N	Reference No.	Description
RESISTORS			
R4443	AE001803	R803R9750J	75 OHM 1/16W
R5003	AE001785	R803R9104J	100K OHM 1/16W
R5004	AE001798	R803R9560J	56 OHM 1/16W
R5005	AE002151	R803R9391J	390 OHM 1/16W
R5006	AE001783	R803R9102J	1K OHM 1/16W
R5007	AE000849	R803R9152J	1.5K OHM 1/16W
R5008	AE001783	R803R9102J	1K OHM 1/16W
R5014	AE001799	R803R9562J	5.6K OHM 1/16W
R5015	AE001799	R803R9562J	5.6K OHM 1/16W
R5016	AE001781	R803R9101J	100 OHM 1/16W
R5017	AE001781	R803R9101J	100 OHM 1/16W
R6605	AE001781	R803R9101J	100 OHM 1/16W
R6606	AE001781	R803R9101J	100 OHM 1/16W
R7201	AE003232	R803R9181J	180 OHM 1/16W
R7202	79091142	R803R9220J	22 OHM 1/16W
R7203	79091142	R803R9220J	22 OHM 1/16W
R8101	AE001887	R803R9105J	1M OHM 1/16W
R8102	AE001887	R803R9105J	1M OHM 1/16W
R8108	AE001784	R803R9103J	10K OHM 1/16W
R8109	AE001887	R803R9105J	1M OHM 1/16W
R8110	AE001887	R803R9105J	1M OHM 1/16W
R8113	AE001785	R803R9104J	100K OHM 1/16W
R8115	AE001801	R803R9682J	6.8K OHM 1/16W
R8116	AE001783	R803R9102J	1K OHM 1/16W
R8117	AE001796	R803R9471J	470 OHM 1/16W
R8119	79091406	R803R9824J	820K OHM 1/16W
R8121	AE002150	R803R9333J	33K OHM 1/16W
R8122	AE001783	R803R9102J	1K OHM 1/16W
R8123	AE002532	R803R9272J	2.7K OHM 1/16W
R8124	AE001781	R803R9101J	100 OHM 1/16W
R8125	AE001788	R803R9123J	12K OHM 1/16W
R8126	AE001781	R803R9101J	100 OHM 1/16W
R8127	AE001783	R803R9102J	1K OHM 1/16W
R8128	AE001788	R803R9123J	12K OHM 1/16W
R8129	AE001893	R803R9332J	3.3K OHM 1/16W
R8130	AD302345	R803R9472J	4.7K OHM 1/16W
R8131	AE001783	R803R9102J	1K OHM 1/16W
R8133	AE002147	R803R9182J	1.8K OHM 1/16W
R8134	AE002147	R803R9182J	1.8K OHM 1/16W
R8137	AE001783	R803R9102J	1K OHM 1/16W
R8512	AE001793	R803R92R2J	2.2 OHM 1/16W
R8513	AE001793	R803R92R2J	2.2 OHM 1/16W
R8529	AD302345	R803R9472J	4.7K OHM 1/16W
R8555	AE001797	R803R9473J	47K OHM 1/16W
△R9001	BZ210080	R0G3K2275K	2.7M OHM 1/2W
△R9002	BZ210206	R002T2155J	1.5M OHM 1/2W
R9003	AD301208	R002T2473J	47K OHM 1/2W
△R9004	BZ210243	R3X181R18J	R,METAL OXIDE 0.18 OHM 1W
R9005	AD301208	R002T2473J	47K OHM 1/2W
R9006	BZ210119	R002T4102J	1K OHM 1/4W
△R9007	BZ210078	R65584101J	R,FUSE 100 OHM 1/4W
R9008	BZ210119	R002T4102J	1K OHM 1/4W
△R9009	AE001883	R3X28A104J	R,METAL OXIDE 100K OHM 2W
R9010	BZ210119	R002T4102J	1K OHM 1/4W
R9012	AD301301	R002T4152J	1.5K OHM 1/4W
R9013	BZ210126	R002T4222J	2.2K OHM 1/4W
R9014	BZ210182	R002T4103J	10K OHM 1/4W
R9015	BZ210233	R4X5T6272F	R,METAL 2.7K OHM 1/6W
R9016	BZ210113	R4X5T6223F	R,METAL 22K OHM 1/6W
R9017	BZ210112	R4X5T6152F	R,METAL 1.5K OHM 1/6W
CAPACITORS			
C101	AE005444	E61UM0221D	220 UF 6.3V
C104	AE000838	CS0PB0N16K	1 UF 10V B
C106	AE002124	CS0PB0315K	0.1 UF 25V B
C107	AE001275	CS0PF0415Z	0.1 UF 50V F
C109	AE002124	CS0PB0315K	0.1 UF 25V B
C110	AE005444	E61UM0221D	220 UF 6.3V
C111	79091061	CS0PCH4G1J	18 PF 50V CH
C113	AE001275	CS0PF0415Z	0.1 UF 50V F
C114	79091061	CS0PCH4G1J	18 PF 50V CH
C116	AE005444	E61UM0221D	220 UF 6.3V

ELECTRICAL REPLACEMENT PARTS LIST

Location No.	TSB P/N	Reference No.	Description
CAPACITORS			
C117	AE001275	CS0PF0415Z	CC 0.1 UF 50V F
C118	AE002124	CS0PB0315K	CC 0.1 UF 25V B
C123	AE002124	CS0PB0315K	CC 0.1 UF 25V B
C125	AE007811	E61UM0101D	CE 100 UF 6.3V
C126	AE001726	CS0PB0414K	CC 0.01 UF 50V B
C127	AE002124	CS0PB0315K	CC 0.1 UF 25V B
C128	AE001275	CS0PF0415Z	CC 0.1 UF 50V F
C131	AE005074	E61UM5R47D	CE 0.47 UF 50V
C136	AE007818	E61UM52R2D	CE 2.2 UF 50V
C139	AE000838	CS0PB0N16K	CC 1 UF 10V B
C303	AE001544	E50HU3100M	CE 10 UF 25 V
C304	AE001725	CS0PB0413K	CC 0.001 UF 50V B
C305	79091097	E50HU2101M	CE 100 UF 16 V
C307	AD301762	E50HU52R2M	CE 2.2 UF 50V
C308	AE007805	E00NU5R47M	CE 0.47 UF 50 V
C309	AE000838	CS0PB0N16K	CC 1 UF 10V B
C310	AE000838	CS0PB0N16K	CC 1 UF 10V B
C311	79091093	E00NU52R2M	CE 2.2 UF 50V
C312	AE001725	CS0PB0413K	CC 0.001 UF 50V B
C313	AE001275	CS0PF0415Z	CC 0.1 UF 50V F
C314	AE001275	CS0PF0415Z	CC 0.1 UF 50V F
C315	AE000272	E50HU2470M	CE 47 UF 16V
C316	BZ110043	E02LU3221M	CE 220 UF 25V
C317	BZ110032	E5EZF3102M	CE 1000 UF 25V
C318	AE002879	CS0PB03Q4K	CC 0.047 UF 25V B
C319	AD301762	E50HU52R2M	CE 2.2 UF 50V
C320	AE002493	CS0PB04L3K	CC 0.0033UF 50V B
C326	AE001725	CS0PB0413K	CC 0.001 UF 50V B
C327	AE001544	E50HU3100M	CE 10 UF 25 V
C328	79091097	E50HU2101M	CE 100 UF 16 V
C329	AD301762	E50HU52R2M	CE 2.2 UF 50V
C330	AE007805	E00NU5R47M	CE 0.47 UF 50 V
C331	AE000838	CS0PB0N16K	CC 1 UF 10V B
C332	AE000838	CS0PB0N16K	CC 1 UF 10V B
C333	79091093	E00NU52R2M	CE 2.2 UF 50V
C334	AE001275	CS0PF0415Z	CC 0.1 UF 50V F
C335	AE001275	CS0PF0415Z	CC 0.1 UF 50V F
C336	AE001725	CS0PB0413K	CC 0.001 UF 50V B
C337	AE000272	E50HU2470M	CE 47 UF 16V
C338	BZ110043	E02LU3221M	CE 220 UF 25V
C339	AE002879	CS0PB03Q4K	CC 0.047 UF 25V B
C341	AD301762	E50HU52R2M	CE 2.2 UF 50V
C342	AE002493	CS0PB04L3K	CC 0.0033UF 50V B
C344	AE000928	E50HU2330M	CE 33 UF 16 V
C810	AE002124	CS0PB0315K	CC 0.1 UF 25V B
C812	AE002124	CS0PB0315K	CC 0.1 UF 25V B
C813	AE002124	CS0PB0315K	CC 0.1 UF 25V B
C814	AE002124	CS0PB0315K	CC 0.1 UF 25V B
C815	AE005444	E61UM0221D	CE 220 UF 6.3V
C816	AE002124	CS0PB0315K	CC 0.1 UF 25V B
C817	AE002124	CS0PB0315K	CC 0.1 UF 25V B
C818	AE002124	CS0PB0315K	CC 0.1 UF 25V B
C819	AE002124	CS0PB0315K	CC 0.1 UF 25V B
C820	AE002124	CS0PB0315K	CC 0.1 UF 25V B
C821	AE002124	CS0PB0315K	CC 0.1 UF 25V B
C822	AE002124	CS0PB0315K	CC 0.1 UF 25V B
C823	AE002124	CS0PB0315K	CC 0.1 UF 25V B
C824	AE002124	CS0PB0315K	CC 0.1 UF 25V B
C826	AE002124	CS0PB0315K	CC 0.1 UF 25V B
C827	AE002124	CS0PB0315K	CC 0.1 UF 25V B
C830	AE002124	CS0PB0315K	CC 0.1 UF 25V B
C832	AE002124	CS0PB0315K	CC 0.1 UF 25V B
C834	AE002124	CS0PB0315K	CC 0.1 UF 25V B
C835	AE002124	CS0PB0315K	CC 0.1 UF 25V B
C836	AE002124	CS0PB0315K	CC 0.1 UF 25V B
C837	AE002124	CS0PB0315K	CC 0.1 UF 25V B
C838	AE002124	CS0PB0315K	CC 0.1 UF 25V B
C839	AE002124	CS0PB0315K	CC 0.1 UF 25V B
C840	AE002124	CS0PB0315K	CC 0.1 UF 25V B
C841	AE002124	CS0PB0315K	CC 0.1 UF 25V B
C842	AE002124	CS0PB0315K	CC 0.1 UF 25V B

ELECTRICAL REPLACEMENT PARTS LIST

Location No.	TSB P/N	Reference No.	Description
CAPACITORS			
C843	AE002124	CS0PB0315K	CC 0.1 UF 25V B
C844	AE002124	CS0PB0315K	CC 0.1 UF 25V B
C845	AE002124	CS0PB0315K	CC 0.1 UF 25V B
C846	AE002124	CS0PB0315K	CC 0.1 UF 25V B
C847	AE002124	CS0PB0315K	CC 0.1 UF 25V B
C849	AE002124	CS0PB0315K	CC 0.1 UF 25V B
C850	AE005444	E61UM0221D	CE 220 UF 6.3V
C851	AE002124	CS0PB0315K	CC 0.1 UF 25V B
C852	AE002124	CS0PB0315K	CC 0.1 UF 25V B
C853	AE002124	CS0PB0315K	CC 0.1 UF 25V B
C855	AE002124	CS0PB0315K	CC 0.1 UF 25V B
C856	AE005444	E61UM0221D	CE 220 UF 6.3V
C857	AE002124	CS0PB0315K	CC 0.1 UF 25V B
C858	AE002124	CS0PB0315K	CC 0.1 UF 25V B
C859	AE002124	CS0PB0315K	CC 0.1 UF 25V B
C860	AE002124	CS0PB0315K	CC 0.1 UF 25V B
C861	AE004237	CS0PCH450C	CC 5 PF 50V CH
C862	AE002124	CS0PB0315K	CC 0.1 UF 25V B
C863	AE002124	CS0PB0315K	CC 0.1 UF 25V B
C868	AE004237	CS0PCH450C	CC 5 PF 50V CH
C870	AE002124	CS0PB0315K	CC 0.1 UF 25V B
C871	AE002124	CS0PB0315K	CC 0.1 UF 25V B
C872	AE002124	CS0PB0315K	CC 0.1 UF 25V B
C873	AE002124	CS0PB0315K	CC 0.1 UF 25V B
C875	AE002124	CS0PB0315K	CC 0.1 UF 25V B
C876	AE002124	CS0PB0315K	CC 0.1 UF 25V B
C877	AE002124	CS0PB0315K	CC 0.1 UF 25V B
C878	AE002124	CS0PB0315K	CC 0.1 UF 25V B
C879	AE002124	CS0PB0315K	CC 0.1 UF 25V B
C883	AE002124	CS0PB0315K	CC 0.1 UF 25V B
C884	AE002124	CS0PB0315K	CC 0.1 UF 25V B
C886	AE002124	CS0PB0315K	CC 0.1 UF 25V B
C887	AE001726	CS0PB0414K	CC 0.01 UF 50V B
C888	AE001725	CS0PB0413K	CC 0.001 UF 50V B
C889	AE002124	CS0PB0315K	CC 0.1 UF 25V B
C891	AE002124	CS0PB0315K	CC 0.1 UF 25V B
C892	AE002124	CS0PB0315K	CC 0.1 UF 25V B
C893	AE002124	CS0PB0315K	CC 0.1 UF 25V B
C894	AE002124	CS0PB0315K	CC 0.1 UF 25V B
C895	AE002124	CS0PB0315K	CC 0.1 UF 25V B
C896	AE002124	CS0PB0315K	CC 0.1 UF 25V B
C897	AE002124	CS0PB0315K	CC 0.1 UF 25V B
C898	AE005444	E61UM0221D	CE 220 UF 6.3V
C902	AE002830	CS0PCH4L1J	CC 33 PF 50V CH
C904	79091070	CS0PCH4U1J	CC 68 PF 50V CH
C2103	AE007811	E61UM0101D	CE 100 UF 6.3V
C2105	AE002124	CS0PB0315K	CC 0.1 UF 25V B
C2106	AE007811	E61UM0101D	CE 100 UF 6.3V
C2108	AE002124	CS0PB0315K	CC 0.1 UF 25V B
C2109	AE002124	CS0PB0315K	CC 0.1 UF 25V B
C2110	AE002124	CS0PB0315K	CC 0.1 UF 25V B
C2111	AE002124	CS0PB0315K	CC 0.1 UF 25V B
C2112	AE002124	CS0PB0315K	CC 0.1 UF 25V B
C2113	AE002124	CS0PB0315K	CC 0.1 UF 25V B
C2116	AE002494	CS0PB04N3K	CC 0.0039UF 50V B
C2120	AE005067	CS0PB03N4K	CC 0.039 UF 25V B
C2121	AE005444	E61UM0221D	CE 220 UF 6.3V
C2124	AE002124	CS0PB0315K	CC 0.1 UF 25V B
C2125	AE002124	CS0PB0315K	CC 0.1 UF 25V B
C2126	AE002124	CS0PB0315K	CC 0.1 UF 25V B
C2127	AE005444	E61UM0221D	CE 220 UF 6.3V
C2129	AE002124	CS0PB0315K	CC 0.1 UF 25V B
C2130	AE002124	CS0PB0315K	CC 0.1 UF 25V B
C2131	AE002124	CS0PB0315K	CC 0.1 UF 25V B
C2132	AE002124	CS0PB0315K	CC 0.1 UF 25V B
C2133	AE005444	E61UM0221D	CE 220 UF 6.3V
C2136	AE002124	CS0PB0315K	CC 0.1 UF 25V B
C2137	AE002124	CS0PB0315K	CC 0.1 UF 25V B
C2138	AE002124	CS0PB0315K	CC 0.1 UF 25V B
C2139	AE002879	CS0PB03Q4K	CC 0.047 UF 25V B
C2140	AE002830	CS0PCH4L1J	CC 33 PF 50V CH

ELECTRICAL REPLACEMENT PARTS LIST

Location No.	TSB P/N	Reference No.	Description
CAPACITORS			
C2143	AE000838	CS0PB0N16K	CC 1 UF 10V B
C2144	AE002879	CS0PB03Q4K	CC 0.047 UF 25V B
C2145	AE001725	CS0PB0413K	CC 0.001 UF 50V B
C2146	AE000840	CS0PCH4K1J	CC 27 PF 50V CH
C2149	AE005444	E61UM0221D	CE 220 UF 6.3V
C2150	AE002124	CS0PB0315K	CC 0.1 UF 25V B
C2151	AE001729	CS0PCH412J	CC 100 PF 50V CH
C2201	BZ110243	CQGTB0414K	CC 0.01 UF 50V B
C2202	BZ110243	CQGTB0414K	CC 0.01 UF 50V B
C2209	BZ110150	E50HU0101M	CE 100 UF 6.3V
C2212	AE002124	CS0PB0315K	CC 0.1 UF 25V B
C2301	AE002124	CS0PB0315K	CC 0.1 UF 25V B
C2302	AE001733	CS0PCH4H2J	CC 220 PF 50V CH
C2303	AE001726	CS0PB0414K	CC 0.01 UF 50V B
C2304	AE002124	CS0PB0315K	CC 0.1 UF 25V B
C2305	AE002124	CS0PB0315K	CC 0.1 UF 25V B
C2306	AE002124	CS0PB0315K	CC 0.1 UF 25V B
C2307	AE002124	CS0PB0315K	CC 0.1 UF 25V B
C2308	AE001727	CS0PB04H3K	CC 0.0022UF 50V B
C2309	AE002124	CS0PB0315K	CC 0.1 UF 25V B
C2310	AE001727	CS0PB04H3K	CC 0.0022UF 50V B
C2311	AE001727	CS0PB04H3K	CC 0.0022UF 50V B
C2312	AE001731	CS0PCH4G2J	CC 180 PF 50V CH
C2314	AE003855	CS0PCH4B2J	CC 120 PF 50V CH
C2316	AE002824	CS0PB04H4K	CC 0.022 UF 50V B
C2318	AE001726	CS0PB0414K	CC 0.01 UF 50V B
C2320	BZ210177	E02LU2470M	CE 47 UF 16V
C2321	BZ110229	E02LU4220M	CE 22 UF 35V
C2322	BZ210177	E02LU2470M	CE 47 UF 16V
C2323	AE002124	CS0PB0315K	CC 0.1 UF 25V B
C2324	AE002124	CS0PB0315K	CC 0.1 UF 25V B
C2325	79091097	E50HU2101M	CE 100 UF 16 V
C2326	AE002124	CS0PB0315K	CC 0.1 UF 25V B
C2329	BZ110263	E50HU2220M	CE 22 UF 16 V
C2330	AE002124	CS0PB0315K	CC 0.1 UF 25V B
C2331	AE001726	CS0PB0414K	CC 0.01 UF 50V B
C2332	AE002124	CS0PB0315K	CC 0.1 UF 25V B
C2333	BZ110263	E50HU2220M	CE 22 UF 16 V
C2334	BZ110263	E50HU2220M	CE 22 UF 16 V
C2339	AE001726	CS0PB0414K	CC 0.01 UF 50V B
C2603	AE001727	CS0PB04H3K	CC 0.0022UF 50V B
C2604	AE001727	CS0PB04H3K	CC 0.0022UF 50V B
C2605	AE001727	CS0PB04H3K	CC 0.0022UF 50V B
C2606	AE001727	CS0PB04H3K	CC 0.0022UF 50V B
C2607	AE002830	CS0PCH4L1J	CC 33 PF 50V CH
C2608	AE001768	E50HU0221M	CE 220 UF 6.3V
C2609	AE001275	CS0PF0415Z	CC 0.1 UF 50V F
C2610	AE000837	CS0PB04U3K	CC 0.0068UF 50V B
C2611	AE001275	CS0PF0415Z	CC 0.1 UF 50V F
C2612	AE002824	CS0PB04H4K	CC 0.022 UF 50V B
C2613	AE001733	CS0PCH4H2J	CC 220 PF 50V CH
C2614	AE002124	CS0PB0315K	CC 0.1 UF 25V B
C2615	AE001275	CS0PF0415Z	CC 0.1 UF 50V F
C2616	AE002831	CS0PCH4Q2J	CC 470 PF 50V CH
C2617	AE002124	CS0PB0315K	CC 0.1 UF 25V B
C2618	AE002124	CS0PB0315K	CC 0.1 UF 25V B
C2619	AE002832	CS0PCH4S2J	CC 560 PF 50V CH
C2620	AE000836	CS0PB04S3K	CC 0.0056UF 50V B
C2621	AE000836	CS0PB04S3K	CC 0.0056UF 50V B
C2622	AE000836	CS0PB04S3K	CC 0.0056UF 50V B
C2623	AE001275	CS0PF0415Z	CC 0.1 UF 50V F
C2624	AE001725	CS0PB0413K	CC 0.001 UF 50V B
C2625	AE001725	CS0PB0413K	CC 0.001 UF 50V B
C2626	AE001275	CS0PF0415Z	CC 0.1 UF 50V F
C2627	AE000835	CS0PB03L4K	CC 0.033 UF 25V B
C2628	AE001725	CS0PB0413K	CC 0.001 UF 50V B
C2629	AE001725	CS0PB0413K	CC 0.001 UF 50V B
C2630	AE000838	CS0PB0N16K	CC 1 UF 10V B
C2631	AE002124	CS0PB0315K	CC 0.1 UF 25V B
C2632	AE001275	CS0PF0415Z	CC 0.1 UF 50V F
C2633	AE001725	CS0PB0413K	CC 0.001 UF 50V B

ELECTRICAL REPLACEMENT PARTS LIST

Location No.	TSB P/N	Reference No.	Description
CAPACITORS			
C2634	AE001275	CS0PF0415Z	CC 0.1 UF 50V F
C2635	AE001725	CS0PB0413K	CC 0.001 UF 50V B
C2636	AE001275	CS0PF0415Z	CC 0.1 UF 50V F
C2637	AE001275	CS0PF0415Z	CC 0.1 UF 50V F
C2638	AE001275	CS0PF0415Z	CC 0.1 UF 50V F
C2639	AE001275	CS0PF0415Z	CC 0.1 UF 50V F
C2640	BZ110150	E50HU0101M	CE 100 UF 6.3V
C2641	BZ110150	E50HU0101M	CE 100 UF 6.3V
C2642	AE001275	CS0PF0415Z	CC 0.1 UF 50V F
C2643	AE001543	E50HU0470M	CE 47 UF 6.3V
C2644	AE001543	E50HU0470M	CE 47 UF 6.3V
C2645	AE001275	CS0PF0415Z	CC 0.1 UF 50V F
C2646	AE001543	E50HU0470M	CE 47 UF 6.3V
C2647	AE001275	CS0PF0415Z	CC 0.1 UF 50V F
C2648	AE000838	CS0PB0N16K	CC 1 UF 10V B
C2654	AE001726	CS0PB0414K	CC 0.01 UF 50V B
C2655	AE001726	CS0PB0414K	CC 0.01 UF 50V B
C3001	AE005079	E62FT3331M	CE 330 UF 25V
C3002	AE002124	CS0PB0315K	CC 0.1 UF 25V B
C3004	AE000838	CS0PB0N16K	CC 1 UF 10V B
C3005	AE002124	CS0PB0315K	CC 0.1 UF 25V B
C3006	AE001726	CS0PB0414K	CC 0.01 UF 50V B
C3007	AE002831	CS0PCH4Q2J	CC 470 PF 50V CH
C3008	AE001726	CS0PB0414K	CC 0.01 UF 50V B
C3009	AE000838	CS0PB0N16K	CC 1 UF 10V B
C3011	AE005079	E62FT3331M	CE 330 UF 25V
C3012	AE001275	CS0PF0415Z	CC 0.1 UF 50V F
C3014	AE001275	CS0PF0415Z	CC 0.1 UF 50V F
C3015	AE005080	E62FU0331M	CE 330 UF 6.3V
C3016	AE002708	E5EJU2101M	CE 100 UF 16V
C3017	AE001275	CS0PF0415Z	CC 0.1 UF 50V F
C3018	AE001737	CS0PF0N16Z	CC 1 UF 10V F
C3019	AE005070	E5EJU0221M	CE 220 UF 6.3V
C3020	AE005080	E62FU0331M	CE 330 UF 6.3V
C3021	AE001275	CS0PF0415Z	CC 0.1 UF 50V F
C3022	AE002708	E5EJU2101M	CE 100 UF 16V
C3023	AE002708	E5EJU2101M	CE 100 UF 16V
C3024	AE001275	CS0PF0415Z	CC 0.1 UF 50V F
C3025	AE002124	CS0PB0315K	CC 0.1 UF 25V B
C3032	AE001275	CS0PF0415Z	CC 0.1 UF 50V F
C3201	AE002831	CS0PCH4Q2J	CC 470 PF 50V CH
C3202	AE002831	CS0PCH4Q2J	CC 470 PF 50V CH
C3204	AE002831	CS0PCH4Q2J	CC 470 PF 50V CH
C3205	AE002831	CS0PCH4Q2J	CC 470 PF 50V CH
C3206	AE002831	CS0PCH4Q2J	CC 470 PF 50V CH
C3207	AE002831	CS0PCH4Q2J	CC 470 PF 50V CH
C3209	AE007813	E61UM2221D	CE 220 UF 16V
C3211	AE001737	CS0PF0N16Z	CC 1 UF 10V F
C3212	AE001737	CS0PF0N16Z	CC 1 UF 10V F
C3213	AE007811	E61UM0101D	CE 100 UF 6.3V
C3215	AE001737	CS0PF0N16Z	CC 1 UF 10V F
C3216	AE001737	CS0PF0N16Z	CC 1 UF 10V F
C3217	AE007811	E61UM0101D	CE 100 UF 6.3V
C3218	AE007258	CS0PB0NH6K	CC 2.2 UF 10V B
C3219	AE007258	CS0PB0NH6K	CC 2.2 UF 10V B
C3221	AE007258	CS0PB0NH6K	CC 2.2 UF 10V B
C3601	AE002831	CS0PCH4Q2J	CC 470 PF 50V CH
C3602	AE002831	CS0PCH4Q2J	CC 470 PF 50V CH
C3604	AE001544	E50HU3100M	CE 10 UF 25 V
C3605	AE001725	CS0PB0413K	CC 0.001 UF 50V B
C3606	AE001275	CS0PF0415Z	CC 0.1 UF 50V F
C3607	AE001275	CS0PF0415Z	CC 0.1 UF 50V F
C3608	AE001275	CS0PF0415Z	CC 0.1 UF 50V F
C3609	AE001725	CS0PB0413K	CC 0.001 UF 50V B
C3610	AE001275	CS0PF0415Z	CC 0.1 UF 50V F
C3611	AE001544	E50HU3100M	CE 10 UF 25 V
C3612	AE001275	CS0PF0415Z	CC 0.1 UF 50V F
C3613	AE001726	CS0PB0414K	CC 0.01 UF 50V B
C3614	AE001275	CS0PF0415Z	CC 0.1 UF 50V F
C3615	AE001544	E50HU3100M	CE 10 UF 25 V
C3616	AE001275	CS0PF0415Z	CC 0.1 UF 50V F

ELECTRICAL REPLACEMENT PARTS LIST

Location No.	TSB P/N	Reference No.	Description
CAPACITORS			
C3617	AE001725	CS0PB0413K	CC 0.001 UF 50V B
C3618	AE001275	CS0PF0415Z	CC 0.1 UF 50V F
C3619	AE001725	CS0PB0413K	CC 0.001 UF 50V B
C3620	AE001725	CS0PB0413K	CC 0.001 UF 50V B
C3621	AE001725	CS0PB0413K	CC 0.001 UF 50V B
C3622	AE001275	CS0PF0415Z	CC 0.1 UF 50V F
C3623	AE002132	CS0PF04Q4Z	CC 0.047 UF 50V F
C3624	AE007797	CS0SB0217K	CC 10 UF 16V B
C3625	AE001275	CS0PF0415Z	CC 0.1 UF 50V F
C3626	AE001725	CS0PB0413K	CC 0.001 UF 50V B
C3627	AE001275	CS0PF0415Z	CC 0.1 UF 50V F
C3628	BZ110263	E50HU2220M	CE 22 UF 16 V
C3629	AE001544	E50HU3100M	CE 10 UF 25 V
C3630	AE001275	CS0PF0415Z	CC 0.1 UF 50V F
C3632	AE001544	E50HU3100M	CE 10 UF 25 V
C3633	AE001275	CS0PF0415Z	CC 0.1 UF 50V F
C3634	BZ110263	E50HU2220M	CE 22 UF 16 V
C3635	AE001275	CS0PF0415Z	CC 0.1 UF 50V F
C3636	BZ110263	E50HU2220M	CE 22 UF 16 V
C3637	AE001275	CS0PF0415Z	CC 0.1 UF 50V F
C3638	AE001275	CS0PF0415Z	CC 0.1 UF 50V F
C3639	AE001275	CS0PF0415Z	CC 0.1 UF 50V F
C3640	AE001275	CS0PF0415Z	CC 0.1 UF 50V F
C3642	AE002129	CS0PCH4E1J	CC 15 PF 50V CH
C3643	AE002129	CS0PCH4E1J	CC 15 PF 50V CH
C3644	AE001275	CS0PF0415Z	CC 0.1 UF 50V F
C3645	AE001737	CS0PF0N16Z	CC 1 UF 10V F
C3646	AE001275	CS0PF0415Z	CC 0.1 UF 50V F
C3647	AE001275	CS0PF0415Z	CC 0.1 UF 50V F
C3648	AE001544	E50HU3100M	CE 10 UF 25 V
C3649	AE001275	CS0PF0415Z	CC 0.1 UF 50V F
C3650	AE001732	CS0PCH4H1J	CC 22 PF 50V CH
C3651	AE001732	CS0PCH4H1J	CC 22 PF 50V CH
C3652	AE001732	CS0PCH4H1J	CC 22 PF 50V CH
C3653	AE001275	CS0PF0415Z	CC 0.1 UF 50V F
C3654	BZ110263	E50HU2220M	CE 22 UF 16 V
C3655	AE001275	CS0PF0415Z	CC 0.1 UF 50V F
C3656	AE001275	CS0PF0415Z	CC 0.1 UF 50V F
C3657	AE001737	CS0PF0N16Z	CC 1 UF 10V F
C3658	BZ110150	E50HU0101M	CE 100 UF 6.3V
C3659	BZ110150	E50HU0101M	CE 100 UF 6.3V
C3661	BZ110263	E50HU2220M	CE 22 UF 16 V
C3663	AE000328	CS0RF0316Z	CC 1 UF 25V F
C3664	AE000328	CS0RF0316Z	CC 1 UF 25V F
C3665	AE001735	CS0PCH4W2J	CC 820 PF 50V CH
C3666	AE001735	CS0PCH4W2J	CC 820 PF 50V CH
C3667	AE002822	CS0PB04E3K	CC 0.0015UF 50V B
C3668	AE002822	CS0PB04E3K	CC 0.0015UF 50V B
C3669	AE001732	CS0PCH4H1J	CC 22 PF 50V CH
C3670	AE001732	CS0PCH4H1J	CC 22 PF 50V CH
C3671	AE001729	CS0PCH412J	CC 100 PF 50V CH
C3672	AE001729	CS0PCH412J	CC 100 PF 50V CH
C3673	AE001544	E50HU3100M	CE 10 UF 25 V
C3674	AE001544	E50HU3100M	CE 10 UF 25 V
C3675	AE001544	E50HU3100M	CE 10 UF 25 V
C3676	AE001544	E50HU3100M	CE 10 UF 25 V
C3677	AE002822	CS0PB04E3K	CC 0.0015UF 50V B
C3678	AE002822	CS0PB04E3K	CC 0.0015UF 50V B
C3679	AE001275	CS0PF0415Z	CC 0.1 UF 50V F
C3680	AE000272	E50HU2470M	CE 47 UF 16V
C3681	AE001275	CS0PF0415Z	CC 0.1 UF 50V F
C3682	AE007796	CS0PF0216Z	CC 1 UF 16V F
C3683	AE007796	CS0PF0216Z	CC 1 UF 16V F
C3684	AE007797	CS0SB0217K	CC 10 UF 16V B
C3685	AE007797	CS0SB0217K	CC 10 UF 16V B
C3802	AE002124	CS0PB0315K	CC 0.1 UF 25V B
C3803	AE000838	CS0PB0N16K	CC 1 UF 10V B
C3804	AE002832	CS0PCH4S2J	CC 560 PF 50V CH
C3805	AE000837	CS0PB04U3K	CC 0.0068UF 50V B
C3806	AE002124	CS0PB0315K	CC 0.1 UF 25V B
C3808	AE005068	CS0PB0415K	CC 0.1 UF 50V B

ELECTRICAL REPLACEMENT PARTS LIST

Location No.	TSB P/N	Reference No.	Description
CAPACITORS			
C3809	AE001726	CS0PB0414K	0.01 UF 50V B
C3810	AE007810	E61FT4331D	330 UF 35V
C3811	AD301535	E02LU2101M	100 UF 16V
C3812	AE007808	E61FF4122N	1200 UF 35V
C3813	AE002124	CS0PB0315K	0.1 UF 25V B
C3814	AE005071	E61FT2681D	680 UF 16V
C3815	AE002879	CS0PB03Q4K	0.047 UF 25V B
C3816	BZ110190	E02LU2221M	220 UF 16V
C3817	AE002124	CS0PB0315K	0.1 UF 25V B
C3818	AE000840	CS0PCH4K1J	27 PF 50V CH
C3819	79091384	CS0PCH4L2J	330 PF 50V CH
C3820	AD301535	E02LU2101M	100 UF 16V
C3821	AE002124	CS0PB0315K	0.1 UF 25V B
C3822	AD301535	E02LU2101M	100 UF 16V
C3823	AE002879	CS0PB03Q4K	0.047 UF 25V B
C3824	AE005071	E61FT2681D	680 UF 16V
C3825	AE002124	CS0PB0315K	0.1 UF 25V B
C3826	AE000840	CS0PCH4K1J	27 PF 50V CH
C3827	AE001726	CS0PB0414K	0.01 UF 50V B
C3828	BZ110255	CQGTB0415K	0.1 UF 50V B
C3830	AE002124	CS0PB0315K	0.1 UF 25V B
C3831	AE001726	CS0PB0414K	0.01 UF 50V B
C3832	AE001726	CS0PB0414K	0.01 UF 50V B
C3834	79091383	CS0PCH4K2J	270 PF 50V CH
C3835	AE005071	E61FT2681D	680 UF 16V
C3837	BZ110190	E02LU2221M	220 UF 16V
C3838	AE005071	E61FT2681D	680 UF 16V
C3839	AE002124	CS0PB0315K	0.1 UF 25V B
C3840	AE005071	E61FT2681D	680 UF 16V
C3841	79091097	E50HU2101M	100 UF 16 V
C3842	AE002879	CS0PB03Q4K	0.047 UF 25V B
C3843	AE002124	CS0PB0315K	0.1 UF 25V B
C3844	AE000840	CS0PCH4K1J	27 PF 50V CH
C3845	79091097	E50HU2101M	100 UF 16 V
C3846	AE001727	CS0PB04H3K	0.0022UF 50V B
C3847	AE001726	CS0PB0414K	0.01 UF 50V B
C3848	AE001726	CS0PB0414K	0.01 UF 50V B
C3850	AE000838	CS0PB0N16K	1 UF 10V B
C3851	AE001133	CQGTF04Q5Z	0.47 UF 50V F
C3853	AE001730	CS0PCH4E2J	150 PF 50V CH
C3854	AE002123	CQGTF0416Z	1 UF 50V F
C3855	AE001133	CQGTF04Q5Z	0.47 UF 50V F
C3856	AE000467	E02LU54R7M	4.7 UF 50V
C3858	AE007258	CS0PB0NH6K	2.2 UF 10V B
C3859	AE001133	CQGTF04Q5Z	0.47 UF 50V F
C3860	AE000467	E02LU54R7M	4.7 UF 50V
C3861	AE005071	E61FT2681D	680 UF 16V
C3862	AE001726	CS0PB0414K	0.01 UF 50V B
C3863	AE007258	CS0PB0NH6K	2.2 UF 10V B
C3864	AE007258	CS0PB0NH6K	2.2 UF 10V B
C3865	AE007258	CS0PB0NH6K	2.2 UF 10V B
C3866	AE007258	CS0PB0NH6K	2.2 UF 10V B
C3867	AE003857	CS0PCH4W1J	82 PF 50V CH
C3870	BZ110207	E02LT2102M	1000 UF 16V
C3871	AE005068	CS0PB0415K	0.1 UF 50V B
C3872	AE002824	CS0PB04H4K	0.022 UF 50V B
C3883	AE005068	CS0PB0415K	0.1 UF 50V B
C4001	AE001275	CS0PF0415Z	0.1 UF 50V F
C4002	AE001275	CS0PF0415Z	0.1 UF 50V F
C4003	AE001275	CS0PF0415Z	0.1 UF 50V F
C4004	AE001275	CS0PF0415Z	0.1 UF 50V F
C4005	AE001275	CS0PF0415Z	0.1 UF 50V F
C4006	AE001275	CS0PF0415Z	0.1 UF 50V F
C4007	AE001275	CS0PF0415Z	0.1 UF 50V F
C4008	AE001275	CS0PF0415Z	0.1 UF 50V F
C4010	AE001275	CS0PF0415Z	0.1 UF 50V F
C4011	AE000336	E02LU1101M	100 UF 10V
C4012	AE001275	CS0PF0415Z	0.1 UF 50V F
C4013	AE001275	CS0PF0415Z	0.1 UF 50V F
C4014	AE001275	CS0PF0415Z	0.1 UF 50V F
C4016	AE001275	CS0PF0415Z	0.1 UF 50V F

ELECTRICAL REPLACEMENT PARTS LIST

Location No.	TSB P/N	Reference No.	Description
CAPACITORS			
C4017	AE001275	CS0PF0415Z	CC 0.1 UF 50V F
C4018	AE001275	CS0PF0415Z	CC 0.1 UF 50V F
C4019	AE001275	CS0PF0415Z	CC 0.1 UF 50V F
C4020	AE001275	CS0PF0415Z	CC 0.1 UF 50V F
C4022	AE001275	CS0PF0415Z	CC 0.1 UF 50V F
C4023	AE001275	CS0PF0415Z	CC 0.1 UF 50V F
C4024	AE001275	CS0PF0415Z	CC 0.1 UF 50V F
C4025	AE001275	CS0PF0415Z	CC 0.1 UF 50V F
C4026	AE001275	CS0PF0415Z	CC 0.1 UF 50V F
C4027	AE001275	CS0PF0415Z	CC 0.1 UF 50V F
C4028	AE001275	CS0PF0415Z	CC 0.1 UF 50V F
C4029	AE001275	CS0PF0415Z	CC 0.1 UF 50V F
C4030	AE001275	CS0PF0415Z	CC 0.1 UF 50V F
C4031	AE001726	CS0PB0414K	CC 0.01 UF 50V B
C4032	AE001725	CS0PB0413K	CC 0.001 UF 50V B
C4033	AE001275	CS0PF0415Z	CC 0.1 UF 50V F
C4034	AE004237	CS0PCH450C	CC 5 PF 50V CH
C4035	AE004238	CS0PCH4F1J	CC 16 PF 50V CH
C4036	AE002825	CS0PCH411D	CC 10 PF 50V CH
C4037	AE001275	CS0PF0415Z	CC 0.1 UF 50V F
C4038	AE001726	CS0PB0414K	CC 0.01 UF 50V B
C4039	AE001275	CS0PF0415Z	CC 0.1 UF 50V F
C4040	AE001275	CS0PF0415Z	CC 0.1 UF 50V F
C4041	AE001275	CS0PF0415Z	CC 0.1 UF 50V F
C4042	AE002825	CS0PCH411D	CC 10 PF 50V CH
C4045	AE001275	CS0PF0415Z	CC 0.1 UF 50V F
C4046	AE001275	CS0PF0415Z	CC 0.1 UF 50V F
C4047	AE001275	CS0PF0415Z	CC 0.1 UF 50V F
C4050	AE001275	CS0PF0415Z	CC 0.1 UF 50V F
C4051	BZ110143	E02LU0221M	CE 220 UF 6.3V
C4052	BZ110143	E02LU0221M	CE 220 UF 6.3V
C4056	AE002825	CS0PCH411D	CC 10 PF 50V CH
C4062	AE001275	CS0PF0415Z	CC 0.1 UF 50V F
C4063	BZ110143	E02LU0221M	CE 220 UF 6.3V
C4064	AE001275	CS0PF0415Z	CC 0.1 UF 50V F
C4067	BZ210177	E02LU2470M	CE 47 UF 16V
C4068	AE003896	E5EZU2470M	CE 47 UF 16V
C4069	AE003896	E5EZU2470M	CE 47 UF 16V
C4070	AE003896	E5EZU2470M	CE 47 UF 16V
C4071	AE003896	E5EZU2470M	CE 47 UF 16V
C4072	AE001275	CS0PF0415Z	CC 0.1 UF 50V F
C4073	AE001275	CS0PF0415Z	CC 0.1 UF 50V F
C4074	AE001275	CS0PF0415Z	CC 0.1 UF 50V F
C4075	AE001275	CS0PF0415Z	CC 0.1 UF 50V F
C4076	AE001275	CS0PF0415Z	CC 0.1 UF 50V F
C4077	AE001275	CS0PF0415Z	CC 0.1 UF 50V F
C4078	AE000336	E02LU1101M	CE 100 UF 10V
C4081	AE001275	CS0PF0415Z	CC 0.1 UF 50V F
C4082	AE001275	CS0PF0415Z	CC 0.1 UF 50V F
C4083	AE000336	E02LU1101M	CE 100 UF 10V
C4085	AE001725	CS0PB0413K	CC 0.001 UF 50V B
C4086	AE001725	CS0PB0413K	CC 0.001 UF 50V B
C4088	AE001726	CS0PB0414K	CC 0.01 UF 50V B
C4089	AE001726	CS0PB0414K	CC 0.01 UF 50V B
C4090	AE001726	CS0PB0414K	CC 0.01 UF 50V B
C4093	AE001729	CS0PCH412J	CC 100 PF 50V CH
C4094	AE001729	CS0PCH412J	CC 100 PF 50V CH
C4095	AE001726	CS0PB0414K	CC 0.01 UF 50V B
C4096	AE001725	CS0PB0413K	CC 0.001 UF 50V B
C4099	AE001726	CS0PB0414K	CC 0.01 UF 50V B
C4312	AE000838	CS0PB0N16K	CC 1 UF 10V B
C4313	AE000838	CS0PB0N16K	CC 1 UF 10V B
C4314	AE000838	CS0PB0N16K	CC 1 UF 10V B
C4315	AE000838	CS0PB0N16K	CC 1 UF 10V B
C4322	AE007811	E61UM0101D	CE 100 UF 6.3V
C4323	AE007812	E61UM2101D	CE 100 UF 16V
C4324	AE007812	E61UM2101D	CE 100 UF 16V
C4325	AE001733	CS0PCH4H2J	CC 220 PF 50V CH
C4326	AE007819	E61UM54R7D	CE 4.7 UF 50V
C4327	AE005444	E61UM0221D	CE 220 UF 6.3V
C4328	AE002124	CS0PB0315K	CC 0.1 UF 25V B

ELECTRICAL REPLACEMENT PARTS LIST

Location No.	TSB P/N	Reference No.	Description
CAPACITORS			
C4329	AE007817	E61UM5220D	22 UF 50V
C4330	AE007818	E61UM52R2D	2.2 UF 50V
C4331	AE007818	E61UM52R2D	2.2 UF 50V
C4332	AE000838	CS0PB0N16K	1 UF 10V B
C4333	AE000838	CS0PB0N16K	1 UF 10V B
C4334	AE000838	CS0PB0N16K	1 UF 10V B
C4336	AE000838	CS0PB0N16K	1 UF 10V B
C4337	AE007812	E61UM2101D	100 UF 16V
C4339	AE007812	E61UM2101D	100 UF 16V
C4340	AE007817	E61UM5220D	22 UF 50V
C4342	AE001275	CS0PF0415Z	0.1 UF 50V F
C4344	AE001729	CS0PCH412J	100 PF 50V CH
C4345	AE001725	CS0PB0413K	0.001 UF 50V B
C4347	AE001725	CS0PB0413K	0.001 UF 50V B
C4349	AE001729	CS0PCH412J	100 PF 50V CH
C4350	AE000838	CS0PB0N16K	1 UF 10V B
C4351	AE000838	CS0PB0N16K	1 UF 10V B
C4352	AE000838	CS0PB0N16K	1 UF 10V B
C4353	AE000838	CS0PB0N16K	1 UF 10V B
C4354	AE007815	E61UM4330D	33 UF 35V
C4355	AE001735	CS0PCH4W2J	820 PF 50V CH
C4356	AE001735	CS0PCH4W2J	820 PF 50V CH
C4357	AE000838	CS0PB0N16K	1 UF 10V B
C4358	AE000838	CS0PB0N16K	1 UF 10V B
C4360	AE007822	E717M4100D	10 UF 35V
C4361	AE007822	E717M4100D	10 UF 35V
C4372	AE002831	CS0PCH4Q2J	470 PF 50V CH
C4378	AE002831	CS0PCH4Q2J	470 PF 50V CH
C4403	BZ110187	E02LT0102M	1000 UF 6.3V
C4407	AE002124	CS0PB0315K	0.1 UF 25V B
C4408	BZ110255	CQGTB0415K	0.1 UF 50V B
C4409	AD301434	E02LU4101M	100 UF 35V
C4410	79091068	CS0PCH4S1J	56 PF 50V CH
C4411	79091068	CS0PCH4S1J	56 PF 50V CH
C4418	AE001725	CS0PB0413K	0.001 UF 50V B
C4419	AE000840	CS0PCH4K1J	27 PF 50V CH
C4420	AE001725	CS0PB0413K	0.001 UF 50V B
C4422	AE000838	CS0PB0N16K	1 UF 10V B
C4423	AE000838	CS0PB0N16K	1 UF 10V B
C4424	AE000838	CS0PB0N16K	1 UF 10V B
C4425	AE000838	CS0PB0N16K	1 UF 10V B
C4426	AD301535	E02LU2101M	100 UF 16V
C4427	AD301535	E02LU2101M	100 UF 16V
C4428	79091070	CS0PCH4U1J	68 PF 50V CH
C4429	79091070	CS0PCH4U1J	68 PF 50V CH
C4430	79091070	CS0PCH4U1J	68 PF 50V CH
C5002	AE002124	CS0PB0315K	0.1 UF 25V B
C5005	AE001729	CS0PCH412J	100 PF 50V CH
C5007	AE002124	CS0PB0315K	0.1 UF 25V B
C5011	AE007258	CS0PB0NH6K	2.2 UF 10V B
C5012	AE007258	CS0PB0NH6K	2.2 UF 10V B
C5013	AE002824	CS0PB04H4K	0.022 UF 50V B
C5014	AD301535	E02LU2101M	100 UF 16V
C5015	AE007258	CS0PB0NH6K	2.2 UF 10V B
C5017	AE001726	CS0PB0414K	0.01 UF 50V B
C5018	AD301535	E02LU2101M	100 UF 16V
C5023	AE002130	CS0PCH4Q1J	47 PF 50V CH
C5024	AE002130	CS0PCH4Q1J	47 PF 50V CH
C6601	AD301348	E02LU5100M	10 UF 50V
C6602	AD301348	E02LU5100M	10 UF 50V
C6603	AE000333	E00NU2220M	22 UF 16V
C6604	AE002831	CS0PCH4Q2J	470 PF 50V CH
C6605	AD301348	E02LU5100M	10 UF 50V
C6606	AE000333	E00NU2220M	22 UF 16V
C6607	AE002822	CS0PB04E3K	0.0015UF 50V B
C6609	AE002124	CS0PB0315K	0.1 UF 25V B
C6610	BZ110217	E50HU53R3M	3.3 UF 50V
C6611	BZ110205	E02LU5220M	22 UF 50V
C6612	BZ110205	E02LU5220M	22 UF 50V
C6613	AE002882	CS0PB0NL5K	0.33 UF 10V B
C6614	AE002882	CS0PB0NL5K	0.33 UF 10V B

ELECTRICAL REPLACEMENT PARTS LIST

Location No.	TSB P/N	Reference No.	Description
CAPACITORS			
C6615	BZ110187	E02LT0102M	CE 1000 UF 6.3V
C6616	AE002882	CS0PB0NL5K	CC 0.33 UF 10V B
C6617	AE002882	CS0PB0NL5K	CC 0.33 UF 10V B
C6618	AE002882	CS0PB0NL5K	CC 0.33 UF 10V B
C6619	AE002822	CS0PB04E3K	CC 0.0015UF 50V B
C6620	AE002882	CS0PB0NL5K	CC 0.33 UF 10V B
C6621	AE002831	CS0PCH4Q2J	CC 470 PF 50V CH
C6622	AE002124	CS0PB0315K	CC 0.1 UF 25V B
C6623	AE001733	CS0PCH4H2J	CC 220 PF 50V CH
C6624	AD301348	E02LU5100M	CE 10 UF 50V
C6626	AE001732	CS0PCH4H1J	CC 22 PF 50V CH
C6627	AE001732	CS0PCH4H1J	CC 22 PF 50V CH
C6628	AE002822	CS0PB04E3K	CC 0.0015UF 50V B
C6629	AD301348	E02LU5100M	CE 10 UF 50V
C6630	AE002831	CS0PCH4Q2J	CC 470 PF 50V CH
C6631	79091068	CS0PCH4S1J	CC 56 PF 50V CH
C6632	79091068	CS0PCH4S1J	CC 56 PF 50V CH
C6633	79091068	CS0PCH4S1J	CC 56 PF 50V CH
C6634	AE002128	CS0PCH480D	CC 8 PF 50V CH
C6635	AE002128	CS0PCH480D	CC 8 PF 50V CH
C6636	AE001727	CS0PB04H3K	CC 0.0022UF 50V B
C6637	AE001727	CS0PB04H3K	CC 0.0022UF 50V B
C7201	AE002124	CS0PB0315K	CC 0.1 UF 25V B
C7202	AE002124	CS0PB0315K	CC 0.1 UF 25V B
C7203	AE005444	E61UM0221D	CE 220 UF 6.3V
C7204	AE002124	CS0PB0315K	CC 0.1 UF 25V B
C7205	AE005444	E61UM0221D	CE 220 UF 6.3V
C7206	AE002124	CS0PB0315K	CC 0.1 UF 25V B
C7207	AE002124	CS0PB0315K	CC 0.1 UF 25V B
C7208	AE005444	E61UM0221D	CE 220 UF 6.3V
C7209	AE005444	E61UM0221D	CE 220 UF 6.3V
C7210	AE002124	CS0PB0315K	CC 0.1 UF 25V B
C7212	AE002124	CS0PB0315K	CC 0.1 UF 25V B
C7213	AE007816	E61UM5010D	CE 1 UF 50V
C7215	AE002124	CS0PB0315K	CC 0.1 UF 25V B
C7217	AE002124	CS0PB0315K	CC 0.1 UF 25V B
C7219	AE005076	E61UMQ331D	CE 330 UF 4V
C7224	AE007813	E61UM2221D	CE 220 UF 16V
C7238	AE007258	CS0PB0NH6K	CC 2.2 UF 10V B
C7239	AE007258	CS0PB0NH6K	CC 2.2 UF 10V B
C7240	AE007258	CS0PB0NH6K	CC 2.2 UF 10V B
C7241	AE007258	CS0PB0NH6K	CC 2.2 UF 10V B
C7242	AE007258	CS0PB0NH6K	CC 2.2 UF 10V B
C8101	AE007814	E61UM2470D	CE 47 UF 16V
C8102	AE002124	CS0PB0315K	CC 0.1 UF 25V B
C8103	AE007820	E61UM5R22D	CE 0.22 UF 50V
C8104	AE007820	E61UM5R22D	CE 0.22 UF 50V
C8105	AE005073	E61UM2100D	CE 10 UF 16V
C8106	AE005073	E61UM2100D	CE 10 UF 16V
C8107	AE005073	E61UM2100D	CE 10 UF 16V
C8108	AE005073	E61UM2100D	CE 10 UF 16V
C8112	AE007258	CS0PB0NH6K	CC 2.2 UF 10V B
C8113	AE007258	CS0PB0NH6K	CC 2.2 UF 10V B
C8114	AE000838	CS0PB0N16K	CC 1 UF 10V B
C8115	AE005073	E61UM2100D	CE 10 UF 16V
C8116	AE002124	CS0PB0315K	CC 0.1 UF 25V B
C8117	AE007820	E61UM5R22D	CE 0.22 UF 50V
C8118	AE005073	E61UM2100D	CE 10 UF 16V
C8119	AE002124	CS0PB0315K	CC 0.1 UF 25V B
C8120	AE007811	E61UM0101D	CE 100 UF 6.3V
C8123	AE001726	CS0PB0414K	CC 0.01 UF 50V B
C8124	AE007812	E61UM2101D	CE 100 UF 16V
C8125	AE005073	E61UM2100D	CE 10 UF 16V
C8126	AE002124	CS0PB0315K	CC 0.1 UF 25V B
C8127	AE002124	CS0PB0315K	CC 0.1 UF 25V B
C8128	AE000838	CS0PB0N16K	CC 1 UF 10V B
C8129	AE002124	CS0PB0315K	CC 0.1 UF 25V B
C8130	AE001732	CS0PCH4H1J	CC 22 PF 50V CH
C8131	AE007812	E61UM2101D	CE 100 UF 16V
C8132	AE005073	E61UM2100D	CE 10 UF 16V
C8133	AE000838	CS0PB0N16K	CC 1 UF 10V B

ELECTRICAL REPLACEMENT PARTS LIST

Location No.	TSB P/N	Reference No.	Description
CAPACITORS			
C8134	AE001726	CS0PB0414K	CC 0.01 UF 50V B
C8135	AE005073	E61UM2100D	CE 10 UF 16V
C8136	AE003854	CS0PCH4B1J	CC 12 PF 50V CH
C8137	79091384	CS0PCH4L2J	CC 330 PF 50V CH
C8138	AE001727	CS0PB04H3K	CC 0.0022UF 50V B
C8139	AE007820	E61UM5R22D	CE 0.22 UF 50V
C8144	AE002124	CS0PB0315K	CC 0.1 UF 25V B
C8146	AE000838	CS0PB0N16K	CC 1 UF 10V B
C8147	AE001735	CS0PCH4W2J	CC 820 PF 50V CH
C8153	AE007812	E61UM2101D	CE 100 UF 16V
C8154	AE002124	CS0PB0315K	CC 0.1 UF 25V B
C8155	AE007258	CS0PB0NH6K	CC 2.2 UF 10V B
C8156	AE007258	CS0PB0NH6K	CC 2.2 UF 10V B
C8157	AE007258	CS0PB0NH6K	CC 2.2 UF 10V B
C8158	AE007258	CS0PB0NH6K	CC 2.2 UF 10V B
C8159	AE007258	CS0PB0NH6K	CC 2.2 UF 10V B
C8160	AE007258	CS0PB0NH6K	CC 2.2 UF 10V B
C8504	AE001730	CS0PCH4E2J	CC 150 PF 50V CH
C8505	AE003854	CS0PCH4B1J	CC 12 PF 50V CH
C8506	AE001730	CS0PCH4E2J	CC 150 PF 50V CH
C8507	AE001730	CS0PCH4E2J	CC 150 PF 50V CH
C8508	AE003854	CS0PCH4B1J	CC 12 PF 50V CH
C8509	AE001730	CS0PCH4E2J	CC 150 PF 50V CH
C8510	AE001730	CS0PCH4E2J	CC 150 PF 50V CH
C8511	AE003854	CS0PCH4B1J	CC 12 PF 50V CH
C8512	AE001730	CS0PCH4E2J	CC 150 PF 50V CH
C8519	AE000336	E02LU1101M	CE 100 UF 10V
C8520	AE001275	CS0PF0415Z	CC 0.1 UF 50V F
C8521	AD301348	E02LU5100M	CE 10 UF 50V
C8522	BZ110189	E02LU0471M	CE 470 UF 6.3V
C8523	BZ110189	E02LU0471M	CE 470 UF 6.3V
C8524	BZ110189	E02LU0471M	CE 470 UF 6.3V
C8564	AE002825	CS0PCH411D	CC 10 PF 50V CH
C8566	AE002130	CS0PCH4Q1J	CC 47 PF 50V CH
△C9001	BZ110035	P2122B104M	CMP 0.1 UF 275V ECQUL
C9002	BZ110182	C03L0R713K	CC 0.001 UF 2KV R
△C9003	BZ110035	P2122B104M	CMP 0.1 UF 275V ECQUL
C9004	AE002968	E5EZU5010M	CE 1 UF 50V
C9005	BZ110243	CQGTB0414K	CC 0.01 UF 50V B
C9006	BZ110098	CHGTB0413K	CC 0.001 UF 50V B
C9007	AE000951	CQGTCH4Q2J	CC 470 PF 50V CH
C9008	AE007806	E5EZU4470M	CE 47 UF 35V
△C9009	AE007821	E62XFC821D	CE 5*35 820 UF 200V
C9010	AE002229	P411F4393J	CMPP 0.039 UF 400V ECWF
△C9011	AE002878	CD39E0MQ3M	CC 0.0047UF 250V
C9012	BZ110255	CQGTB0415K	CC 0.1 UF 50V B
C9013	BZ110243	CQGTB0414K	CC 0.01 UF 50V B
C9014	BZ110175	C03L0R7H2K	CC 220 PF 2KV R
△C9015	AE007807	E61FF4122D	CE 1200 UF 35V
△C9016	AE007807	E61FF4122D	CE 1200 UF 35V
C9017	AE007809	E61FT4221D	CE 220 UF 35V
C9018	BZ110243	CQGTB0414K	CC 0.01 UF 50V B
C9019	BZ110176	C03L0R7Q2K	CC 470 PF 2KV R
△C9020	BZ110035	P2122B104M	CMP 0.1 UF 275V ECQUL
△C9021	AD301026	CD39E0M13M	CC 0.001 UF 250V
DIODES			
D101	AE004795	DE7RB5R62B	DIODE,ZENER UDZS5.6B TE-17
D105	AE007801	DD7R20S300	DIODE,SCHOTTKY BARRIER RB520S-30-TE61
D106	AE004795	DE7RB5R62B	DIODE,ZENER UDZS5.6B TE-17
D109	AE007801	DD7R20S300	DIODE,SCHOTTKY BARRIER RB520S-30-TE61
D301	BZ410010	D28T21DQN9	DIODE,SCHOTTKY 21DQ09N-TA2B1
D302	BZ410010	D28T21DQN9	DIODE,SCHOTTKY 21DQ09N-TA2B1
D2201	BZ410087	0021E2Q140	LED LTL-1CHEE-002A
D2601	BZ410121	DDARDS1200	DIODE,SILICON KDS120RTK
D2602	AE004646	DE5RB2R21X	DIODE,ZENER 02DZ2.2-X(TH3ORION)
D3001	AE004643	D28R1QS040	DIODE EC31QS04-TE12L
D3002	AE004642	D28R03A040	DIODE,SCHOTTKY NSQ03A04-TE16L
D3003	AE004643	D28R1QS040	DIODE EC31QS04-TE12L
D3206	AE004643	D28R1QS040	DIODE EC31QS04-TE12L
D3207	AE004643	D28R1QS040	DIODE EC31QS04-TE12L
D3601	AE004937	D77R1A1R10	DIODE,VARISTA AVR1161A1R1NT

ELECTRICAL REPLACEMENT PARTS LIST

Location No.	TSB P/N	Reference No.	Description
DIODES			
D3602	AE004795	DE7RB5R62B	DIODE,ZENER UDZS5.6B TE-17
D3603	AE004937	D77R1A1R10	DIODE,VARISTA AVR1.161A1R1NT
D3604	AE004793	DD7R60L400	DIODE,SCHOTTKY RB160L-40-TE25
D3605	AE004793	DD7R60L400	DIODE,SCHOTTKY RB160L-40-TE25
D3609	AE004794	DE7RB3R32B	DIODE,ZENER UDZS3.3B TE-17
D3613	AE004794	DE7RB3R32B	DIODE,ZENER UDZS3.3B TE-17
D3801	BZ410010	D28T21DQN9	DIODE,SCHOTTKY 21DQ09N-TA2B1
D3802	AE007802	DE7RB1802B	DIODE,ZENER UDZS18B TE-17
D3803	BZ410033	D28T21DQN4	DIODE,SCHOTTKY 21DQ04N-TA2B1
D3804	BZ410010	D28T21DQN9	DIODE,SCHOTTKY 21DQ09N-TA2B1
D3805	BZ410086	DD7R0S3550	DIODE,SILICON 1SS355 TE-17
D3806	BZ410086	DD7R0S3550	DIODE,SILICON 1SS355 TE-17
D3809	BZ410033	D28T21DQN4	DIODE,SCHOTTKY 21DQ04N-TA2B1
D3810	BZ410086	DD7R0S3550	DIODE,SILICON 1SS355 TE-17
D3812	AE006060	D28T0ERB20	DIODE,RECTIFIER 10ERB20-TA1B2
D3813	AE007803	DE7RB8R22B	DIODE,ZENER UDZS8.2B TE-17
D3814	BZ410033	D28T21DQN4	DIODE,SCHOTTKY 21DQ04N-TA2B1
D3815	AE004795	DE7RB5R62B	DIODE,ZENER UDZS5.6B TE-17
D3817	BZ410086	DD7R0S3550	DIODE,SILICON 1SS355 TE-17
D3818	AE006060	D28T0ERB20	DIODE,RECTIFIER 10ERB20-TA1B2
D3819	BZ410010	D28T21DQN9	DIODE,SCHOTTKY 21DQ09N-TA2B1
D3820	AE004643	D28R1QS040	DIODE EC31QS04-TE12L
D4002	BZ410086	DD7R0S3550	DIODE,SILICON 1SS355 TE-17
D4301	AE004795	DE7RB5R62B	DIODE,ZENER UDZS5.6B TE-17
D4302	AE004795	DE7RB5R62B	DIODE,ZENER UDZS5.6B TE-17
D4310	BZ410086	DD7R0S3550	DIODE,SILICON 1SS355 TE-17
D5001	AE007801	DD7R20S300	DIODE,SCHOTTKY BARRIER RB520S-30-TE61
D8508	BZ410086	DD7R0S3550	DIODE,SILICON 1SS355 TE-17
D8509	BZ410086	DD7R0S3550	DIODE,SILICON 1SS355 TE-17
D8510	BZ410086	DD7R0S3550	DIODE,SILICON 1SS355 TE-17
△D9001	AE003872	DOU002720M	DIODE,VARISTA DSS-272M-S00B
△D9002	AE004936	D6EQ27110A	DIODE,VARISTA ENE271D-10A
△D9003	BZ410031	D6CE24110A	DIODE,VARISTA ENE241D-10A-Q6
△D9004	AE007799	D2BE0406H0	DIODE,BRIDGE RBV-406H
D9005	BZ410006	D1VT001330	DIODE,SILICON 1SS133T-77
△D9006	BZ410022	D97U06R81B	DIODE,ZENER MTZJ6.8B T-77
D9007	BZ410006	D1VT001330	DIODE,SILICON 1SS133T-77
D9008	AE007798	D2B0RU3AM0	DIODE,SILICON RU3AM
D9009	AE007010	D28X0ERB20	DIODE,RECTIFIER 10ERB20-TA2B5
△D9010	AE007800	D2CA2C15R0	DIODE,SCHOTTKY BARRIER YG862C15R
△D9011	AE007800	D2CA2C15R0	DIODE,SCHOTTKY BARRIER YG862C15R
△D9012	AE007800	D2CA2C15R0	DIODE,SCHOTTKY BARRIER YG862C15R
ICS			
IC101	AE007838	S5U902DM01	MEMORY DATA OEC7133A
IC102	79097849	I9UF032290	IC PST3229NR
IC104	AE007834	S5U902DE01	MEMORY DATA BR24L64F-WE2
△IC301	AE007823	I03DP901E0	IC LA4901-E
△IC302	AE007823	I03DP901E0	IC LA4901-E
IC801	AE007829	I56K04A710	IC R8J66604A71FP
IC2101	AE005610	IFS0883C0	IC MST9883C-LF-110
IC2301	AE000100	I06F030180	IC M63018FP
IC2304	AD301770	I07E00358F	IC BA10358F-E2
IC2601	AE000841	ICQK067070	IC ZR36707TQC
△IC3001	AE004650	I07F097430	IC BA9743AFV-E2
△IC3002	AE006395	I0GF91ZPH0	IC PQ070XZ01ZPH
△IC3003	AE004653	I1KF98D050	IC KIA78D05F
△IC3201	AE007825	I07F0C0WFO	IC BA00BC0WFP-E2
△IC3202	AE007825	I07F0C0WFO	IC BA00BC0WFP-E2
IC3601	AE004654	I1KF98D330	IC KIA78D33F
IC3602	AE004654	I1KF98D330	IC KIA78D33F
IC3604	AE001295	I0QJ045800	IC NJM4580M(TE1)
IC3605	AE004805	I5PF099930	IC SII9993CTG100
IC3606	AE007836	S5U902DE03	MEMORY DATA BR24L02F-WE2
IC3607	AE004802	I1FF043340	IC CS4334-KSZR
IC3608	AE007835	S5U902DE02	MEMORY DATA BR24L32F-WE2
IC3611	AE006399	ICMF08RD20	IC SST89E58RD2-40-C-TQJE
IC3612	AE003923	I5CF01G080	IC SN74AHC1G08DCKR
IC3801	AE007824	I07F093000	IC BD9300FV-E2
△IC3802	AE004656	I1LF010100	IC AL1010
△IC3803	AE007825	I07F0C0WFO	IC BA00BC0WFP-E2
△IC3804	AE007827	I0GA9090R0	IC PQ090RDA1SZH

ELECTRICAL REPLACEMENT PARTS LIST

Location No.	TSB P/N	Reference No.	Description
ICs			
△ IC3805	AE004656	I1LF010100	AL1010
△ IC3806	AE007825	I07F0C0WF0	BA00BC0WFP-E2
△ IC3809	AE004656	I1LF010100	AL1010
△ IC3810	AE004648	I03D979950	LA7995M-TLM
IC4001	AE003586	ICQK06762V	ZR36762PQCG_V
IC4002	AE006854	I57J0L04F0	BR24L04F-WE2
IC4005	AE006855	IFQJ0A6BE6	EDS6416AHTA-6B-E
IC4007	AE007837	S5U902DF01	MEMORY DATA
IC4301	AD301988	I0UF015010	MM1501XNRE
IC4302	AD301988	I0UF015010	MM1501XNRE
IC4303	AE001295	I0QJ045800	NJM4580M(Te1)
IC4304	BZ611139	I0QF02534V	NJM2534V(Te2)
IC4305	BZ611139	I0QF02534V	NJM2534V(Te2)
IC5001	BZ611139	I0QF02534V	NJM2534V(Te2)
IC6601	AE007828	I19FF4440G	MSP4440G-QA-C13-100
IC7201	AE004660	IFKJ0LM850	DTC34LM85AL
IC8101	AE004651	I0QF025840	NJM2584AM(Te1)
IC8102	AE004800	I05FE13830	TA1383FG
IC8103	AD301988	I0UF015010	MM1501XNRE
IC8104	AE004651	I0QF025840	NJM2584AM(Te1)
IC8150	AD301988	I0UF015010	MM1501XNRE
IC8151	AD301988	I0UF015010	MM1501XNRE
IC8152	AD301988	I0UF015010	MM1501XNRE
IC8502	AE003584	I17F017530	PCM1753DBQR
△ IC9001	AE007826	I0BT0X6730	STR-X6737
△ IC9002	AD302211	I1KJ9A431A	KIA431A-AT
△ IC9003	AE002809	000220002W	PHOTO COUPLER
			PS2561AL1-1-V(W)
TRANSISTORS			
Q101	BZ510021	TNYJC05001	COMPOUND TRANSISTOR
Q105	BZ510026	TPYJC05001	COMPOUND TRANSISTOR
Q301	AE004662	T93A018020	TRANSISTOR,SILICON
Q302	AE004662	T93A018020	TRANSISTOR,SILICON
Q307	AE002626	T8YJ2412K0	TRANSISTOR,SILICON
Q2101	BZ510001	T6YJ1037K0	TRANSISTOR,SILICON
Q2601	BZ510112	T67J1036K0	TRANSISTOR,SILICON
Q2602	AE003592	T67J048TL0	TRANSISTOR,SILICON
Q2603	BZ510113	T27T030180	FET
Q2604	BZ510113	T27T030180	FET
Q2605	BZ510113	T27T030180	FET
Q2606	BZ510021	TNYJC05001	COMPOUND TRANSISTOR
Q3001	AE004661	T77J011320	TRANSISTOR,SILICON
Q3002	BZ510020	TNYJB05001	COMPOUND TRANSISTOR
Q3003	AE002626	T8YJ2412K0	TRANSISTOR,SILICON
Q3004	BZ510108	TAAA1504SY	TRANSISTOR,SILICON
Q3005	AE002626	T8YJ2412K0	TRANSISTOR,SILICON
Q3006	BZ510108	TAAA1504SY	TRANSISTOR,SILICON
△ Q3007	AE004663	TJ5M081090	FET
△ Q3008	AE004663	TJ5M081090	FET
Q3205	AE004661	T77J011320	TRANSISTOR,SILICON
Q3206	BZ510071	TNAAB05003	COMPOUND TRANSISTOR
Q3207	AE004661	T77J011320	TRANSISTOR,SILICON
Q3208	BZ510071	TNAAB05003	COMPOUND TRANSISTOR
Q3209	BZ510071	TNAAB05003	COMPOUND TRANSISTOR
Q3603	BZ510113	T27T030180	FET
Q3604	BZ510113	T27T030180	FET
Q3605	BZ510113	T27T030180	FET
Q3606	BZ510113	T27T030180	FET
Q3607	BZ510113	T27T030180	FET
Q3608	BZ510081	TPYJA05001	COMPOUND TRANSISTOR
Q3609	BZ510045	TNYJD05001	COMPOUND TRANSISTOR
Q3610	AE002626	T8YJ2412K0	TRANSISTOR,SILICON
Q3611	AE002626	T8YJ2412K0	TRANSISTOR,SILICON
Q3612	BZ510045	TNYJD05001	COMPOUND TRANSISTOR
Q3613	AE002626	T8YJ2412K0	TRANSISTOR,SILICON
Q3801	AE007840	T87J2411K0	TRANSISTOR,SILICON
Q3802	BZ510112	T67J1036K0	TRANSISTOR,SILICON
Q3803	AE007839	T0300J6500	FET
Q3804	BZ510057	TAAT01281Y	TRANSISTOR,SILICON
Q3805	BZ510020	TNYJB05001	COMPOUND TRANSISTOR
Q3806	BZ510021	TNYJC05001	COMPOUND TRANSISTOR
Q3807	BZ510071	TNAAB05003	COMPOUND TRANSISTOR

ELECTRICAL REPLACEMENT PARTS LIST

Location No.	TSB P/N	Reference No.	Description
TRANSISTORS			
Q3808	AE002626	T8YJ2412K0	TRANSISTOR,SILICON 2SC2412KT146 R,S
Q3809	BZ510049	TPYJD05001	COMPOUND TRANSISTOR DTA144EKAT146
Q3810	AE002626	T8YJ2412K0	TRANSISTOR,SILICON 2SC2412KT146 R,S
Q3811	AE002626	T8YJ2412K0	TRANSISTOR,SILICON 2SC2412KT146 R,S
Q3812	AE007842	TJ7M50P030	FET RSS050P03_TB
Q3813	AE004665	TS3M000044	COMPOUND TRANSISTOR CPH6312-TL-E
Q3814	AE004665	TS3M000044	COMPOUND TRANSISTOR CPH6312-TL-E
Q3815	AE007841	TJ7I90P030	FET RSS090P03_TB
Q3816	BZ510109	TCAA3875SY	TRANSISTOR,SILICON KTC3875S_Y_RTK
Q3817	BZ510109	TCAA3875SY	TRANSISTOR,SILICON KTC3875S_Y_RTK
Q3819	BZ510109	TCAA3875SY	TRANSISTOR,SILICON KTC3875S_Y_RTK
Q3820	AE007841	TJ7I90P030	FET RSS090P03_TB
Q4301	AE002626	T8YJ2412K0	TRANSISTOR,SILICON 2SC2412KT146 R,S
Q4302	AE002626	T8YJ2412K0	TRANSISTOR,SILICON 2SC2412KT146 R,S
Q4303	AE002626	T8YJ2412K0	TRANSISTOR,SILICON 2SC2412KT146 R,S
Q4304	AE002626	T8YJ2412K0	TRANSISTOR,SILICON 2SC2412KT146 R,S
Q4305	AE002626	T8YJ2412K0	TRANSISTOR,SILICON 2SC2412KT146 R,S
Q4306	BZ510045	TNYJD05001	COMPOUND TRANSISTOR DTC144EKAT146
Q4307	AE002626	T8YJ2412K0	TRANSISTOR,SILICON 2SC2412KT146 R,S
Q4308	BZ510107	TPAAA05001	COMPOUND TRANSISTOR KRA101SRTK
Q4309	BZ510067	TNAAC05002	COMPOUND TRANSISTOR KRC103SRTK
Q4401	AE002626	T8YJ2412K0	TRANSISTOR,SILICON 2SC2412KT146 R,S
Q4402	AE002626	T8YJ2412K0	TRANSISTOR,SILICON 2SC2412KT146 R,S
Q4403	AE002626	T8YJ2412K0	TRANSISTOR,SILICON 2SC2412KT146 R,S
Q4404	AE002626	T8YJ2412K0	TRANSISTOR,SILICON 2SC2412KT146 R,S
Q5002	AE002626	T8YJ2412K0	TRANSISTOR,SILICON 2SC2412KT146 R,S
Q5004	BZ510113	T27T030180	FET 2SK3018T106
Q5005	BZ510113	T27T030180	FET 2SK3018T106
Q8101	BZ510001	T6YJ1037K0	TRANSISTOR,SILICON 2SA1037AKT146R,S
Q8102	AE002626	T8YJ2412K0	TRANSISTOR,SILICON 2SC2412KT146 R,S
Q8103	AE002626	T8YJ2412K0	TRANSISTOR,SILICON 2SC2412KT146 R,S
Q8104	BZ510071	TNAAB05003	COMPOUND TRANSISTOR KRC102SRTK
Q8507	AE002626	T8YJ2412K0	TRANSISTOR,SILICON 2SC2412KT146 R,S
COILS & TRANSFORMERS			
L301	AE004595	021404221M	COIL 21A 220 UH
L302	AE004595	021404221M	COIL 21A 220 UH
L804	AE007760	0216SD4R7J	COIL 4.7 UH
L2101	AE005284	0216S8220K	COIL F 22 UH
L2102	AE005284	0216S8220K	COIL F 22 UH
L2103	AE005285	0216S8470K	COIL F 47 UH
L2106	AE007759	0216S45R6J	COIL 5.6 UH
L2107	AE005284	0216S8220K	COIL F 22 UH
L3001	AE004593	021404101L	COIL 1A 100 UH
L3002	AE004593	021404101L	COIL 1A 100 UH
L3003	BZ310191	02167F2R2J	COIL 2.2 UH
L3004	BZ310150	02167E220K	COIL R7 22 UH
L3601	AE004752	02D6000068	COIL,CHOKE ACM2012D-900-2P-T00
L3602	AE004752	02D6000068	COIL,CHOKE ACM2012D-900-2P-T00
L3603	AE004752	02D6000068	COIL,CHOKE ACM2012D-900-2P-T00
L3604	AE004752	02D6000068	COIL,CHOKE ACM2012D-900-2P-T00
L3801	AD301785	02167E100K	COIL R6-1 10 UH
L3802	AE004594	021404150M	COIL 50A 15 UH
L3804	BZ310150	02167E220K	COIL R7 22 UH
L3805	AE007757	021404470M	COIL 70A 47 UH
L3806	AE007757	021404470M	COIL 70A 47 UH
L3807	BZ310150	02167E220K	COIL R7 22 UH
L3808	AE007757	021404470M	COIL 70A 47 UH
L4001	AE004601	0216SD1R5J	COIL 1.5 UH
L4301	AE005285	0216S8470K	COIL F 47 UH
L4306	AE005284	0216S8220K	COIL F 22 UH
L4307	AE005284	0216S8220K	COIL F 22 UH
L4401	BZ310039	02167F220J	COIL 22 UH
L4402	AD301989	0216A6330J	COIL 33 UH
L5001	BZ310041	02167F101J	COIL 100 UH
L5002	BZ310040	02167F470J	COIL 47 UH
L6601	BZ310141	02167F100J	COIL 10 UH
L6602	BZ310141	02167F100J	COIL 10 UH
L6603	BZ310141	02167F100J	COIL 10 UH
L7201	AE005285	0216S8470K	COIL F 47 UH
L7202	AE005285	0216S8470K	COIL F 47 UH
L7203	AE005285	0216S8470K	COIL F 47 UH

ELECTRICAL REPLACEMENT PARTS LIST

Location No.	TSB P/N	Reference No.	Description
COILS & TRANSFORMERS			
L8101	AE005284	0216S8220K	COIL F 22 UH
L8102	AE005285	0216S8470K	COIL F 47 UH
L8103	AE005285	0216S8470K	COIL F 47 UH
L8150	AE005285	0216S8470K	COIL F 47 UH
L8502	AE000828	02167F1R0K	COIL 1 UH
L8503	AE000828	02167F1R0K	COIL 1 UH
L8504	AE000828	02167F1R0K	COIL 1 UH
L9002	AE007758	0214646R8M	COIL 6.8 UH
L9003	AE007764	02DX000075	COIL,CHOKE ST-202SB
△ T9001	AE007765	0481420734	TRANSFORMER,SWITCHING 81420734
JACKS			
J3601	AE002950	060J421037	RCA JACK MTJ-032-05A-32-FE
J3602	AE002951	060J421030	RCA JACK MTJ-032-05A-31-FE
△ J3802	AE007766	0602606001	JACK DC TCS7960-4320177
△ J4301	AE002426	0602131008	HEADPHONE JACK HSJ0913-01-140
J4302	AE002950	060J421037	RCA JACK MTJ-032-05A-32-FE
J4303	AE002951	060J421030	RCA JACK MTJ-032-05A-31-FE
J4304	AE002950	060J421037	RCA JACK MTJ-032-05A-32-FE
J4305	AE002951	060J421030	RCA JACK MTJ-032-05A-31-FE
J4306	AE002949	060J421036	RCA JACK MTJ-032-05A-30-FE
J4401	AE004334	063D700009	JACK MDC-070V-A_LF
J4402	AE002949	060J421036	RCA JACK MTJ-032-05A-30-FE
J4403	AE002950	060J421037	RCA JACK MTJ-032-05A-32-FE
J4404	AE002951	060J421030	RCA JACK MTJ-032-05A-31-FE
J4405	AE002951	060J421030	RCA JACK MTJ-032-05A-31-FE
J4406	AE005146	060J421043	RCA JACK MTJ-032-05A-29-FE
J4407	AE005147	060J421044	RCA JACK MTJ-032-05A-50-FE
J4408	AE002950	060J421037	RCA JACK MTJ-032-05A-32-FE
J4409	AE002951	060J421030	RCA JACK MTJ-032-05A-31-FE
J5001	AE003568	060J401102	RCA JACK MSP-251V-05NI-FE-LF
△ J9001	AE007767	064Q1A0003	JACK,AC CCT2302-0911
SWITCHES			
SW2201	BZ612010	0504101T34	SWITCH,TACT EVQ21505R
SW2202	BZ612010	0504101T34	SWITCH,TACT EVQ21505R
SW2203	BZ612010	0504101T34	SWITCH,TACT EVQ21505R
SW2204	BZ612010	0504101T34	SWITCH,TACT EVQ21505R
SW2206	BZ612010	0504101T34	SWITCH,TACT EVQ21505R
SW2208	BZ612010	0504101T34	SWITCH,TACT EVQ21505R
SW2209	BZ612010	0504101T34	SWITCH,TACT EVQ21505R
SW2251	BZ612010	0504101T34	SWITCH,TACT EVQ21505R
SW2252	BZ612010	0504101T34	SWITCH,TACT EVQ21505R
SW2253	BZ612010	0504101T34	SWITCH,TACT EVQ21505R
SW2254	BZ612010	0504101T34	SWITCH,TACT EVQ21505R
SW2255	BZ612010	0504101T34	SWITCH,TACT EVQ21505R
P.C.BOARD ASSEMBLIES			
PCB130	AE007788	A5U902D130	PCB ASS'Y DMD005C
PCB270	AE007789	A5U902D270	PCB ASS'Y CEE057A
PCB280	AE007790	A5U902D280	PCB ASS'Y DED007C
PCBC00	AE007791	A5U902DC00	PCB ASS'Y CEE068A
P.C.BOARD ASSEMBLIES			
PCBD20	AE007792	A5U902DD20	PCB ASS'Y CME030A
PCBDA0	AE007793	A5U902DDA0	PCB ASS'Y CEE067A
PCBDJ0	AE007794	A5U902DDJ0	PCB ASS'Y CED011A
PCBDS0	AE007795	A5U902DDS0	PCB ASS'Y CEE082A
MISCELLANEOUS			
B301	BZ310121	024HT03553	CORE,BEADS W5RH3.5X5X1.0
B702	BZ310121	024HT03553	CORE,BEADS W5RH3.5X5X1.0
B801	AE007762	024AC5600E	CORE,BEADS BLM18BB600SN1D
B802	AE007762	024AC5600E	CORE,BEADS BLM18BB600SN1D
B804	AE007762	024AC5600E	CORE,BEADS BLM18BB600SN1D
B805	AE007762	024AC5600E	CORE,BEADS BLM18BB600SN1D
B2101	AE007762	024AC5600E	CORE,BEADS BLM18BB600SN1D
B2301	BZ310186	024HC31022	CORE,BEADS FCM2012H-102T04
B2601	BZ310186	024HC31022	CORE,BEADS FCM2012H-102T04
B2602	BZ310186	024HC31022	CORE,BEADS FCM2012H-102T04
B2603	BZ310186	024HC31022	CORE,BEADS FCM2012H-102T04
B2604	BZ310186	024HC31022	CORE,BEADS FCM2012H-102T04
B2605	BZ310186	024HC31022	CORE,BEADS FCM2012H-102T04
B3001	BZ310186	024HC31022	CORE,BEADS FCM2012H-102T04
B3201	AE007761	024AC5181J	CORE,BEADS BLM18PG181SN1D
B3202	AE007761	024AC5181J	CORE,BEADS BLM18PG181SN1D

ELECTRICAL REPLACEMENT PARTS LIST

Location No.	TSB P/N	Reference No.	Description
MISCELLANEOUS			
B3203	AE007761	024AC5181J	CORE,BEADS
B3204	AE007761	024AC5181J	CORE,BEADS
B3205	AE007761	024AC5181J	CORE,BEADS
B3206	AE007761	024AC5181J	CORE,BEADS
B3207	AE007761	024AC5181J	CORE,BEADS
B3601	AE004602	024HC36001	CORE,BEADS
B3602	AE004602	024HC36001	CORE,BEADS
B3603	AE004602	024HC36001	CORE,BEADS
B3604	AE004602	024HC36001	CORE,BEADS
B3608	AE004602	024HC36001	CORE,BEADS
B3609	AE004602	024HC36001	CORE,BEADS
B3610	BZ310186	024HC31022	CORE,BEADS
B3611	BZ310186	024HC31022	CORE,BEADS
B3801	BZ310121	024HT03553	CORE,BEADS
B3802	BZ310129	024HT03564	CORE,BEADS
B3803	BZ310129	024HT03564	CORE,BEADS
B3804	BZ310121	024HT03553	CORE,BEADS
B3805	BZ310121	024HT03553	CORE,BEADS
B3806	BZ310121	024HT03553	CORE,BEADS
B3807	AE007761	024AC5181J	CORE,BEADS
B3811	AE007761	024AC5181J	CORE,BEADS
B3812	AE007761	024AC5181J	CORE,BEADS
B3813	AE007761	024AC5181J	CORE,BEADS
B3814	AE007761	024AC5181J	CORE,BEADS
B4001	BZ310186	024HC31022	CORE,BEADS
B4002	BZ310186	024HC31022	CORE,BEADS
B4003	BZ310186	024HC31022	CORE,BEADS
B4004	BZ310186	024HC31022	CORE,BEADS
B4005	BZ310186	024HC31022	CORE,BEADS
B4006	BZ310186	024HC31022	CORE,BEADS
B4007	BZ310186	024HC31022	CORE,BEADS
B4008	BZ310186	024HC31022	CORE,BEADS
B4009	BZ310186	024HC31022	CORE,BEADS
B4010	BZ310186	024HC31022	CORE,BEADS
B4301	AE005476	0246C51024	CORE,BEADS
B4302	AE005476	0246C51024	CORE,BEADS
B4303	AE007762	024AC5600E	CORE,BEADS
B4304	AE007762	024AC5600E	CORE,BEADS
B4305	AE007762	024AC5600E	CORE,BEADS
B5001	BZ310121	024HT03553	CORE,BEADS
B8503	BZ310186	024HC31022	CORE,BEADS
B9001	BZ310122	024HT03563	CORE,BEADS
B9002	BZ310121	024HT03553	CORE,BEADS
BT001	AE005640	141R004016	BATTERY,MANGAN
BT002	AE005640	141R004016	BATTERY,MANGAN
CD301	AE007770	06C3145002	CORD,CONNECTOR
△CD501	AE007774	06C3242901	CORD,CONNECTOR
△CD505	AE004631	120G119903	CORD,SET AC
CD701	AE007778	06C32G1601	CORD,CONNECTOR
CD801	AE007786	122H0T0801	CORD,JUMPER
CD802	AE007787	122H0U0802	CORD,JUMPER
CP101	AD300752	069S250629	CONNECTOR PCB SIDE
CP102	BZ614213	069S2A0629	CONNECTOR PCB SIDE
CP103	BZ614242	069S260629	CONNECTOR PCB SIDE
CP301	AD301045	069S140419	CONNECTOR PCB SIDE
CP801	AE007769	069EVT3030	CONNECTOR PCB SIDE
CP802	AE006528	069EVU3030	CONNECTOR PCB SIDE
CD2200	AE007773	06C3234501	CORD,CONNECTOR
CD2202	AE007775	06C3251802	CORD,CONNECTOR
CD2251	AE007772	06C3220704	CORD,CONNECTOR
CD2601	AE001699	122H0O1902	CORD,JUMPER
CD3601	AE007771	06C31K3201	CORD,CONNECTOR
CD3801	AE007777	06C32E3801	CORD,CONNECTOR
△CD3804	AE007776	06C32B1801	CORD,CONNECTOR
CD7202	AE007779	06CHRU3401	CORD,CONNECTOR
△CD9002	AE007785	1208414305	CORD DC
△CF9001	AE007763	029X000135	COIL,LINE FILTER
△CF9002	AE006198	029X000131	COIL,LINE FILTER
CP2200	BZ614350	069S230629	CONNECTOR PCB SIDE
CP2251	AE005287	069S220639	CONNECTOR PCB SIDE
CP2301	AE006524	069EV93030	CONNECTOR PCB SIDE
			BLM18PG181SN1D
			BLM18PG181SN1D
			BLM18PG181SN1D
			BLM18PG181SN1D
			BLM18PG181SN1D
			HCB2012K-600T25
			HCB2012K-600T25
			HCB2012K-600T25
			HCB2012K-600T25
			HCB2012K-600T25
			HCB2012K-600T25
			FCM2012H-102T04
			FCM2012H-102T04
			W5RH3.5X5X1.0
			W4BRH3.5X6X1.0
			W4BRH3.5X6X1.0
			W5RH3.5X5X1.0
			W5RH3.5X5X1.0
			W5RH3.5X5X1.0
			BLM18PG181SN1D
			BLM18PG181SN1D
			BLM18PG181SN1D
			BLM18PG181SN1D
			BLM18PG181SN1D
			FCM2012H-102T04
			FCM2012H-102T04
			FCM2012H-102T04
			FCM2012H-102T04
			FCM2012H-102T04
			FCM2012H-102T04
			FCM2012H-102T04
			FCM2012H-102T04
			FCM2012H-102T04
			FCM2012H-102T04
			FCM2012H-102T04
			MMZ1608R102CT
			MMZ1608R102CT
			BLM18BB600SN1D
			BLM18BB600SN1D
			BLM18BB600SN1D
			W5RH3.5X5X1.0
			FCM2012H-102T04
			W4BRH3.5X6X1.0X2
			W5RH3.5X5X1.0
			GR03X-SP2
			GR03X-SP2
			C3145002
			C3242901
			0G119903
			C32G1601
			2H0T0801
			2H0U0802
			A2001WV2-5P
			A2001WV2-10P
			A2001WV2-6P
			A2502WV2-4P
			00_6232_029_006_800+
			00_6232_030_006_800+
			C3234501
			C3251802
			C3220704
			2H0O1902
			C31K3201
			C32E3801
			C32B1801
			CHRU3401
			1208414305
			SS30V-R150270
			SS26V-R150162
			A2001WV2-3P
			A2001WR2-2P
			00_6232_009_006_800+

ELECTRICAL REPLACEMENT PARTS LIST

Location No.	TSB P/N	Reference No.	Description		
MISCELLANEOUS					
	CP2302	AE006525	069EVC3030	CONNECTOR PCB SIDE	00_6232_012_006_800+
	CP2601	AE003571	069GYOT119	CONNECTOR PCB SIDE	09-5000-024-001-001
	CP3201	BZ614214	069S2B0629	CONNECTOR PCB SIDE	A2001WV2-11P
	CP3601	AE004763	069HYJ3010	CONNECTOR PCB SIDE	DC1R019JDA
	CP3604	BZ614239	069S290639	CONNECTOR PCB SIDE	A2001WR2-9P
△	CP3801	BZ614459	069S2E0629	CONNECTOR PCB SIDE	A2001WV2-14P
△	CP3802	AD301998	069S240629	CONNECTOR PCB SIDE	A2001WV2-4P
	CP4301	AE005152	069S1K0019	CONNECTOR PCB SIDE	A2501WV2-20P
	CP4302	AE007768	0694S15017	CONNECTOR PCB SIDE	1-1734344-1
	CP4303	AE004336	069S2G0629	CONNECTOR PCB SIDE	A2001WV2-16P
	CP4401	AE006528	069EVU3030	CONNECTOR PCB SIDE	00_6232_030_006_800+
	CP5001	AE007769	069EVT3030	CONNECTOR PCB SIDE	00_6232_029_006_800+
	CP5002	AD300752	069S250629	CONNECTOR PCB SIDE	A2001WV2-5P
	CP7203	AE005151	069HVWT04A	CONNECTOR PCB SIDE	FI-X30S-HF-NPB
△	CP9001	BZ614444	069D01001A	CONNECTOR PCB SIDE	003P-2100
	CUS811	BZ710279	800WFAA006	CUSHION A	
	ELC001	BZ614043	124116281A	EYE LET	XRY16X28BD
	ELC002	BZ614044	124120301A	EYE LET	XRY20X30BD
△	F3001	AE004626	083LA05007	FUSE	1206FA5A-T
△	F3801	AE004624	0835C05003	MICRO FUSE	20N_5000FS
△	F9001	BZ614422	081PC6R305	FUSE	51MS063L
△	F9002	AE007782	08ATC03001	FUSE	HU5X-24.5
△	F9003	AE004346	0835A07005	MICRO FUSE	20N_7000FSW
	FH9001	AE002634	06710T0009	HOLDER,FUSE	EYF-52BCY
	FH9002	AE002634	06710T0009	HOLDER,FUSE	EYF-52BCY
	NR801	AE006386	110P4000M4	R,NETWORK	4D03WVGJ0000T5E
	NR802	AE005937	110P4470M4	R,NETWORK	4D03WVGJ0470T5E
	NR803	AE005937	110P4470M4	R,NETWORK	4D03WVGJ0470T5E
	NR804	AE005937	110P4470M4	R,NETWORK	4D03WVGJ0470T5E
	NR805	AE005937	110P4470M4	R,NETWORK	4D03WVGJ0470T5E
	NR806	AE005937	110P4470M4	R,NETWORK	4D03WVGJ0470T5E
	NR807	AE005937	110P4470M4	R,NETWORK	4D03WVGJ0470T5E
	NR2101	AE004680	110P4101M4	R,NETWORK	4D03WVGJ0101T5E
	NR2102	AE004680	110P4101M4	R,NETWORK	4D03WVGJ0101T5E
	NR2103	AE004680	110P4101M4	R,NETWORK	4D03WVGJ0101T5E
	NR2104	AE004680	110P4101M4	R,NETWORK	4D03WVGJ0101T5E
	NR2105	AE004680	110P4101M4	R,NETWORK	4D03WVGJ0101T5E
	NR2106	AE004680	110P4101M4	R,NETWORK	4D03WVGJ0101T5E
	NR7201	AE005599	110P4220M4	R,NETWORK	4D03WVGJ0220T5E
	NR7202	AE005599	110P4220M4	R,NETWORK	4D03WVGJ0220T5E
	OS2202	AE004623	0773071006	REMOTE RECEIVER	RPM7138-SH8
△	SP301	AE007780	070N546013	SPEAKER	YDP4010-12
△	SP302	AE007780	070N546013	SPEAKER	YDP4010-12
	TM101	AE007781	076D0LT010	TRANSMITTER	ORV205N1505026-J
	TR301	BZ310181	02A6B2E0A1	CORE,FERRITE	HF70T22*10*14
△	TH9001	AE007804	DSR0LDNB00	THERMISTOR	NTPAA2R2LDNB0
	TR3801	BZ310118	02AHB9A972	CORE,FERRITE	W5T29X7.5X19
	TR3805	BZ310118	02AHB9A972	CORE,FERRITE	W5T29X7.5X19
△	TU4401	AE006829	0162300045	RF UNIT	115-V-LA35AR
△	V2301	AE007783	09ES120001	LCD	LC200WX1-SL01
	X101	AE004780	100WT01611	CRYSTAL	HC-49/U-S
	X801	AE007784	100YT05401	CRYSTAL	FCX-03
	X3601	AE004779	100CT01101	CRYSTAL	HC-49/U-S
	X4001	AD301803	100BT02701	CRYSTAL	HC-49U/S
	X6601	BZ613042	100CT01803	CRYSTAL	HC-49/U-S
	X8101	AE005441	100DA3R529	CRYSTAL	HC-49/U
	X8102	AE004348	1002R01502	CERAMIC OSCILLATOR	CSBLA503KECZF30-B0

RESISTOR

RC..... CARBON RESISTOR

CAPACITORS

CC..... CERAMIC CAPACITOR
 CE..... ALUMI ELECTROLYTIC CAPACITOR
 CP..... POLYESTER CAPACITOR
 CPP..... POLYPROPYLENE CAPACITOR
 CPL..... PLASTIC CAPACITOR
 CMP..... METAL POLYESTER CAPACITOR
 CMPL..... METAL PLASTIC CAPACITOR
 CMPP..... METAL POLYPROPYLENE CAPACITOR

TOSHIBA CORPORATION

1-1, SHIBAURA 1-CHOME, MINATO-KU, TOKYO 105-8001, JAPAN