

TOSHIBA

FILE NO. 020-200204

SERVICE MANUAL

COLOR TELEVISION

N2S Chassis

32A62

(TAC0203)

TABLE OF CONTENTS

CHAPTER 1 GENERAL ADJUSTMENTS

SAFETY INSTRUCTIONS	3
SET-UP ADJUSTMENT	4
SERVICE MODE	8
DESIGN MODE	11
ELECTRICAL ADJUSTMENT	12
CIRCUIT CHECKS	15

CHAPTER 2 SPECIFIC INFORMATIONS

SETTING & ADJUSTING DATA	16
LOCATION OF CONTROLS	17
PROGRAMMING CHANNEL MEMORY	19
CHASSIS AND CABINET REPLACEMENT PARTS LIST	20
PC BOARDS BOTTOM VIEW	29
TERMINAL VIEW OF TRANSISTORS	34
CIRCUIT BLOCK DIAGRAM	36
SPECIFICATIONS	END

APPENDIX:

CIRCUIT DIAGRAM

SAFETY INSTRUCTIONS

WARNING: BEFORE SERVICING THIS CHASSIS, READ THE “X-RAY RADIATION PRECAUTION”, “SAFETY PRECAUTION” AND “PRODUCT SAFETY NOTICE” INSTRUCTIONS BELOW.

X-RAY RADIATION PRECAUTION

- Excessive high voltage can produce potentially hazardous X-RAY RADIATION. To avoid such hazards, the high voltage must not be above the specified limit. The nominal value of the high voltage of this receiver is (A) kV at zero beam current (minimum brightness) under a 120V AC power source. The high voltage must not, under any circumstances, exceed (B) kV.

Refer to table-1 for high voltage (A), (B).
(See SETTING & ADJUSTING DATA on page 16)

Each time a receiver requires servicing, the high voltage should be checked following the HIGH VOLTAGE CHECK procedure in this manual. It is recommended that the reading of the high voltage be recorded as a part of the service record. It is important to use an accurate and reliable high voltage meter.
- This receiver is equipped with a Fail Safe (FS) circuit which prevents the receiver from producing an excessively high voltage even if the B+ voltage increases abnormally. Each time the receiver is serviced, the FS circuit must be checked to determine that the circuit is properly functioning, following the FS CIRCUIT CHECK procedure in this manual.
- The only source of X-RAY RADIATION in this TV receiver is the picture tube. For continued X-RAY RADIATION protection, the replacement tube must be exactly the same type tube as specified in the parts list.
- Some part in this receiver have special safety-related characteristics for X-RAY RADIATION protection. For continued safety, parts replacement should be undertaken only after referring to the PRODUCT SAFETY NOTICE below.

SAFETY PRECAUTION

WARNING : Service should not be attempted by anyone unfamiliar with the necessary precautions on this receiver. The following are the necessary precautions to be observed before servicing this chassis.

- An isolation Transformer should be connected in the power line between the receiver and the AC line before any service is performed on the receiver.
- Always discharge the picture tube anode to the CRT conductive coating before handling the picture tube. The picture tube is highly evacuated and if broken, glass fragments will be violently expelled. Use shatter proof goggles and keep picture tube away from the unprotected body while handling.
- When replacing a chassis in the cabinet, always be certain that all the protective devices are put back in place, such as; non-metallic control knobs, insulating covers, shields, isolation resistor-capacitor network etc.
- Before returning the set to the customer, always perform an AC leakage current check on the exposed metallic parts of the cabinet, such as antennas, terminals, screwheads, metal overlays, control shafts etc. to be sure the set is safe to operate without danger of electrical shock. Plug the AC line cord directly into a 120V AC outlet (do not use a line isolation transformer during this check). Use an AC voltmeter having 5000 ohms per volt or more sensitivity in the following manner:

Connect a 1500 ohm 10 watt resistor, paralleled by a 0.15 μ F, AC type capacitor, between a known good earth ground (water pipe, conduit, etc.) and the exposed metallic parts, one at a time. Measure the AC voltage across the combination of 1500 ohm resistor and 0.15 μ F capacitor. Reverse the AC plug at the AC outlet and repeat AC voltage measurements for each exposed metallic part. Voltage measured must not exceed 0.3 volts rms. This corresponds to 0.2 milliamp. AC. Any value exceeding this limit constitutes a potential shock hazard and must be corrected immediately.

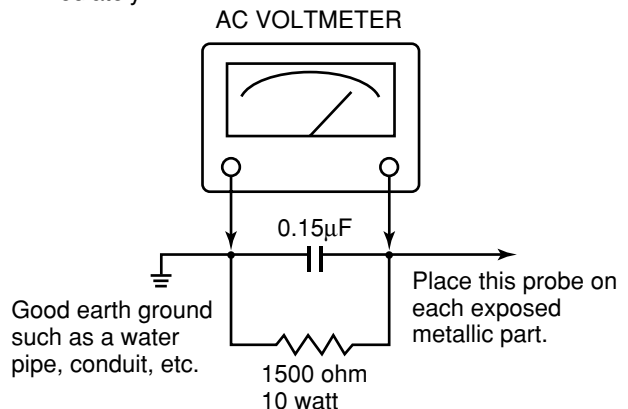

PRODUCT SAFETY NOTICE

Many electrical and mechanical parts in this chassis have special safety-related characteristics. These characteristics are often passed unnoticed by a visual inspection and the protection afforded by them cannot necessarily be obtained by using replacement components rated for higher voltage, wattage, etc. Replacement parts which have these special safety characteristics are identified in this manual and its supplements; electrical components having such features are identified by the international hazard symbols on the schematic diagram and the parts list.

Before replacing any of these components, read the parts list in this manual carefully. The use of substitute replacement parts which do not have the same safety characteristics as specified in the parts list may create shock, fire, X-ray radiation or other hazards.

WARNING: BEFORE SERVICING THIS CHASSIS, READ THE "X-RAY RADIATION PRECAUTION", "SAFETY PRECAUTION" AND "PRODUCT SAFETY NOTICE" ON PAGE 3 OF THIS MANUAL.

SET-UP ADJUSTMENT (FOR 13", 14", 19", 20")

■ The following adjustments should be made when a complete realignment is required or a new picture tube is installed. Perform the adjustments in order as follows :

1. Color Purity
2. Convergence
3. White Balance

Note: The PURITY/CONVERGENCE MAGNET assembly and rubber wedges need mechanical positioning.

Refer to figure 1.

Mounting position of the purity magnet assembly should fit to same position as old one because slightly difference to the position depend on a kind of tube.

* There are no adjustment of purity and convergence in some picture tube (Unified with purity magnet)

COLOR PURITY ADJUSTMENT

NOTE : Before attempting any purity adjustments, the receiver should be operated for at least fifteen minutes.

1. Demagnetize the picture tube and cabinet using a degaussing coil.
2. Set the brightness and contrast to maximum.
3. Use a green raster from among the built-in test signals.
4. Loosen the clamp screw holding the yoke and slide the yoke backward or forward to provide vertical green belt (zone) in the picture screen.
5. Remove the Rubber Wedges.
6. Rotate and spread the tabs of the purity magnet (See figure 2.) around the neck of the picture tube until the green belt is in the center of the screen. At the same time, enter the raster vertically.
7. Slowly move the yoke forward or backward until a uniform green screen is obtained. Tighten the clamp screw of the yoke temporarily.
8. Check the purity of the red and blue raster.

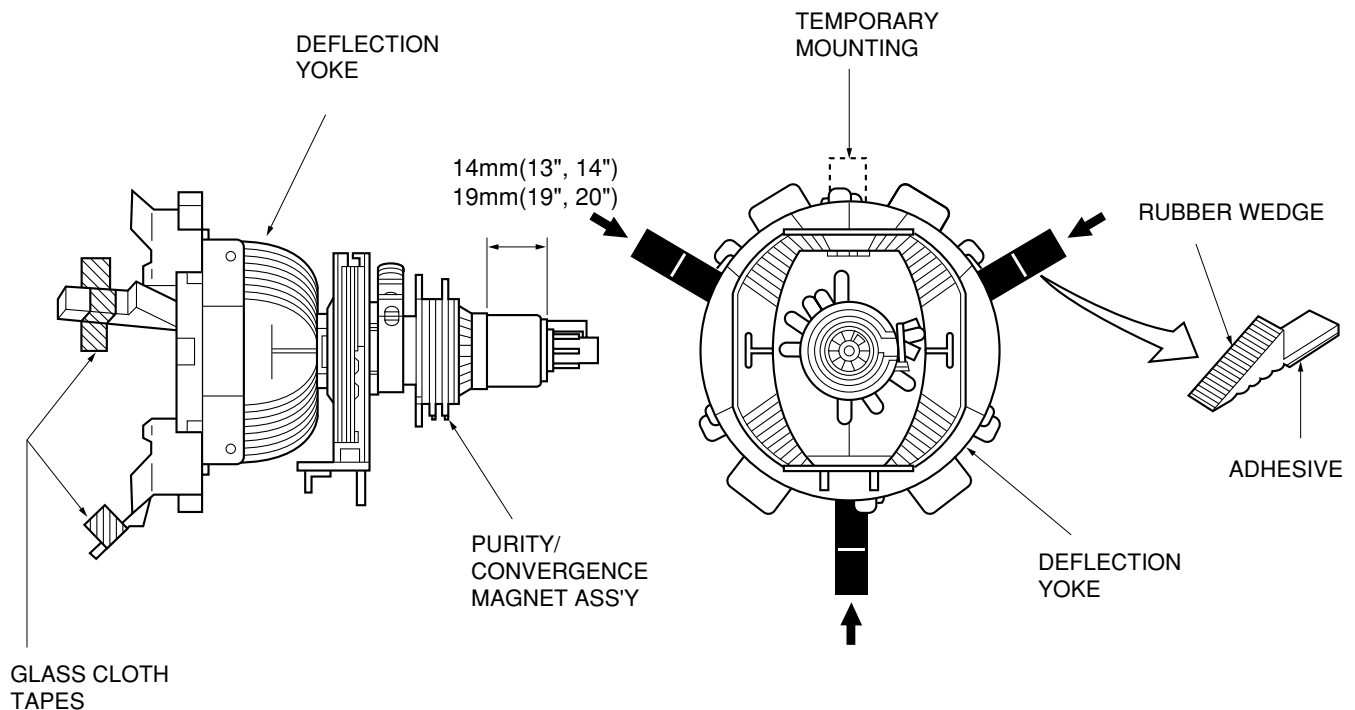

Figure 1.

CONVERGENCE ADJUSTMENTS

NOTE: Before attempting any convergence adjustments, the receiver should be operated for at least fifteen minutes.

■ **CENTER CONVERGENCE ADJUSTMENT**

1. Use the cross-dot pattern from among the built-in test signals.
2. Set the brightness and contrast for well defined pattern.
3. Adjust two tabs of the 4-Pole Magnets to change the angle between them (See figure 2.) and superimpose red and blue vertical lines in the center area of the picture screen.
4. Turn the both tabs at the same time keeping the angle constant to superimpose red and blue horizontal lines at the center of the screen.
5. Adjust two tabs of 6-Pole Magnets to superimpose red/blue line and green one. Adjusting the angle affects the vertical lines and rotating both magnets affects the horizontal lines.
6. Repeat adjustments 3, 4, 5 keeping in mind red, green and blue movement, because 4-Pole Magnets and 6-Pole Magnets have mutual interaction and make dot movement complex.

■ **CIRCUMFERENCE CONVERGENCE ADJUSTMENT**

1. Loosen the clamping screw of deflection yoke slightly to allow the yoke to tilt.
2. Temporarily put a wedge as shown in figure 1. (Do not remove cover paper on adhesive part of the wedge.)
3. Tilt front of the deflection yoke up or down to obtain better convergence in circumference. (See figure 3.) Push the mounted wedge into the space between picture tube and the yoke to fix the yoke temporarily.
4. Put other wedge into bottom space and remove the cover paper to stick.
5. Tilt front of the yoke right or left to obtain better convergence in circumference. (See figure 3.)
6. Keep the yoke position and put another wedge in either upper space. Remove cover paper and stick the wedge on picture tube to fix the yoke.
7. Detach the temporarily mounted wedge and put it in another upper space. Stick it on picture tube to fix the yoke.
8. After fixing three wedges, recheck overall convergence. Tighten the screw firmly to fix the yoke and check the yoke is firm.
9. Stick three adhesive tapes on wedges as shown in figure 1.

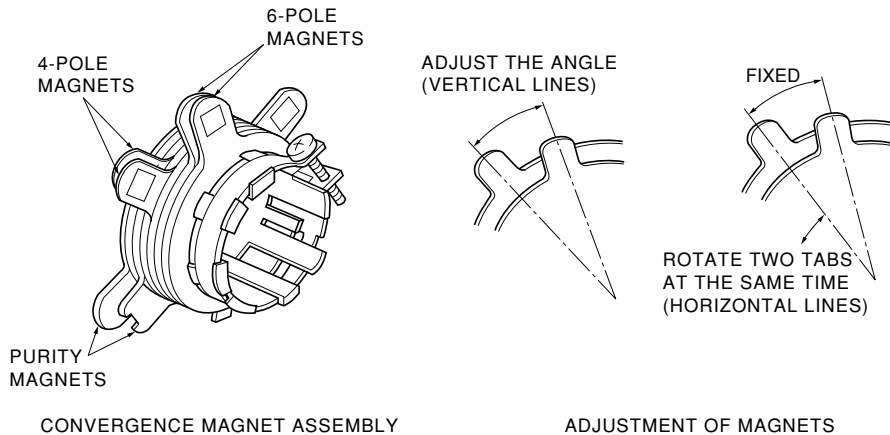
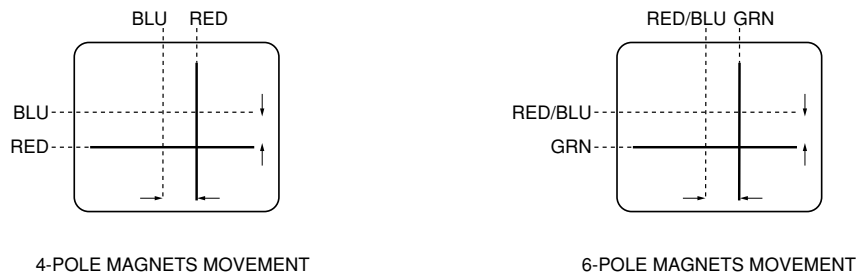

Figure 2.



Center Convergence by Convergence Magnets



Circumference Convergence by DEF Yoke

Figure 3. Dot Movement Pattern

WARNING: BEFORE SERVICING THIS CHASSIS, READ THE "X-RAY RADIATION PRECAUTION", "SAFETY PRECAUTION" AND "PRODUCT SAFETY NOTICE" ON PAGE 3 OF THIS MANUAL.

(FOR 35", 36")

- The following adjustments should be made when a complete realignment is required or a new picture tube is installed. Perform the adjustments in order as follows :

1. Color Purity
2. Convergence
3. White Balance

Note: The PURITY/CONVERGENCE MAGNET assembly and rubber wedges need mechanical positioning.

Refer to figure 1.

Mounting position of the purity magnet assembly should fit to same position as old one because slightly difference to the position depend on a kind of tube.

- * There are no adjustment of purity and convergence in some picture tube (Unified with purity magnet)

COLOR PURITY ADJUSTMENT

NOTE : Before attempting any purity adjustments, the receiver should be operated for at least fifteen minutes.

1. Evenly degauss the entire screen.
2. Set the CONTRAST and BRIGHTNESS Controls to the maximum.
3. Display built-in green raster using the TEST SIGNAL SELECTION function.
4. Loosen the clamp screw holding the deflection yoke (and remove the Rubber Wedges).
5. Slide the yoke forward or backward to provide vertical green belt (zone) in the picture screen.
6. Rotate and spread the tabs of the purity magnet (See figure 3.) around the neck of the picture tube until the green belt is in the center of the screen. At the same time, center the raster vertically by adjusting the magnet as shown below.

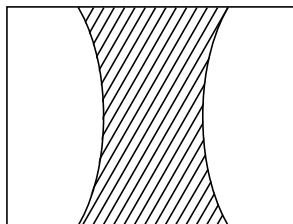

Green Belt

7. Move the yoke slowly forward or backward until a uniform green screen is obtained. Tighten the clamp screw of the yoke temporarily.
8. Check the purity of the red and blue raster.
9. Put four wedges into the space between the picture tube and the yoke to hold the yoke in the adjusted position. (See figure 2.)
Do not tilt the yoke by excessive insertion of the wedge.
10. Remove cover paper of wedge and stick wedges on the tube to fix the yoke in the adjusted position.
Fix the wedges with glass cloth tapes.

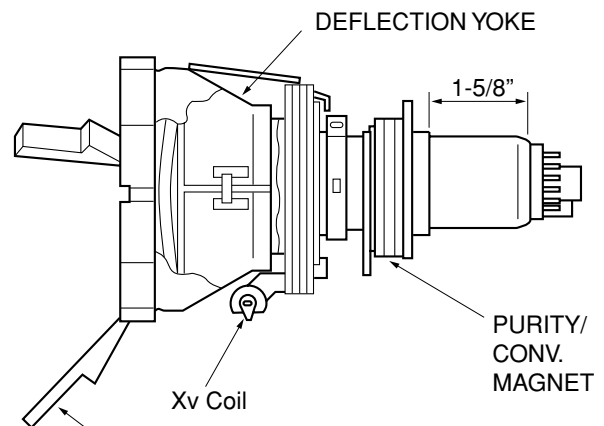

Figure 1.

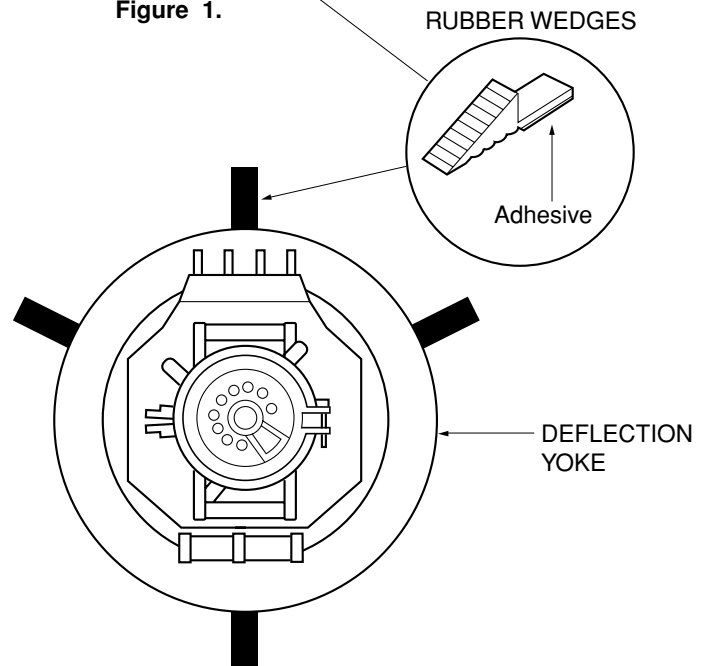

Figure 2.

CONVERGENCE ADJUSTMENTS

NOTE: Before attempting any convergence adjustments, the receiver should be operated for at least fifteen minutes.

■ **CENTER CONVERGENCE ADJUSTMENT**

1. Display built-in cross-dot pattern using the TEST SIGNAL SELECTION function.
2. Adjust the BRIGHTNESS and CONTRAST Controls for well defined pattern.
3. Loosen the tightening ring and adjust two tabs of the 4-Pole Magnets to change the angle between them (See figure 3.) and superimpose red and blue vertical lines in the center area of the picture screen. (See figure 4.)
4. Turn the both tabs at the same time keeping the constant angle to superimpose red and blue horizontal lines at the centre of the screen. (See figure 4.)
5. Adjust two tabs of 6-Pole Magnets to superimpose red/blue line with green one. Adjusting the angle affects the vertical lines and rotating both magnets affects the horizontal lines.
6. Repeat adjustments 3, 4, 5 keeping in mind red, green and blue movement, because 4-Pole Magnets and 6-Pole magnets interact and make dot movement complex.
7. After completing the "CENTER CONVERGENCE ADJUSTMENT" tighten the tightening ring to fix the magnets.

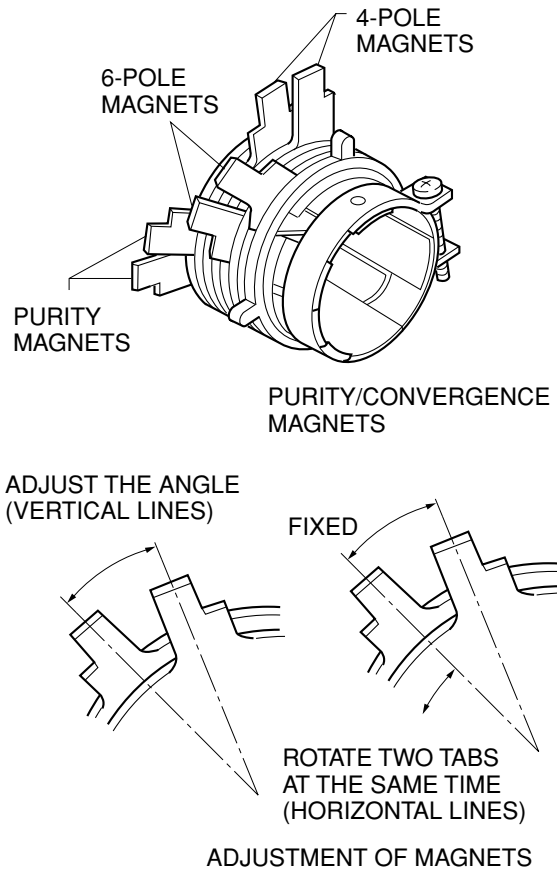
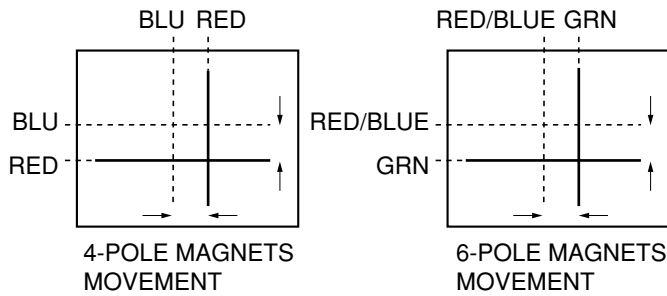

Figure 3.



Center Convergence by Convergence Magnets

Figure 4.

■ **Xv COIL ADJUSTMENT**

Adjust the Xv coil (on the deflection yoke) to correct misconvergence at both sides on screen. Use a hexagonal tip stick (plastic) to adjust the core of coil.

Clockwise Adjustment Counterclockwise Adjustment

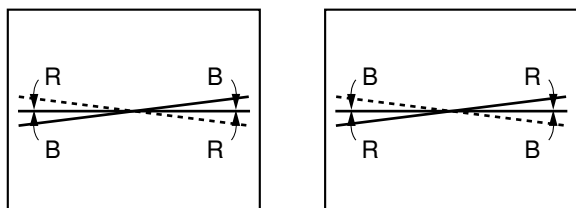

X_v Cross Pattern View

■ **SCREEN-CORNER CONVERGENCE**

When the misconvergence is still evident on corners even though the above adjustment is done, use the ferrite sheet (Part No. 23993622) to correct misconvergence.

1. Put ferrite sheets into the space under the yoke. Decide such position that misconvergence becomes minimum, watching picture screen. (See figure below.)
2. Remove cover paper of ferrite sheet to stick it in the place on the tube. Put adhesive tapes on ferrite sheets to fix.

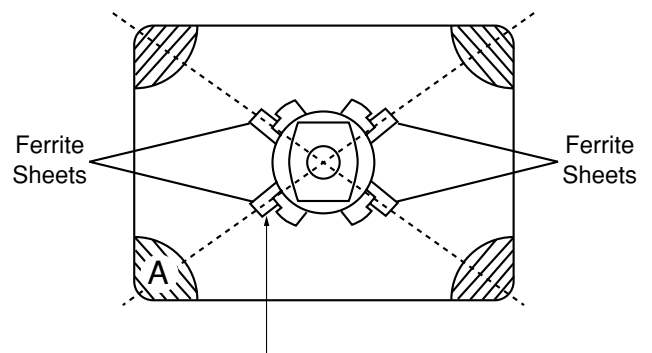

For correcting misconvergence on the position A

SERVICE MODE

1. ENTERING TO SERVICE MODE

- 1) Press MUTE button once on Remote Control.
- 2) Press MUTE button again to keep pressing.
- 3) While pressing the MUTE button, press MENU button on TV set.

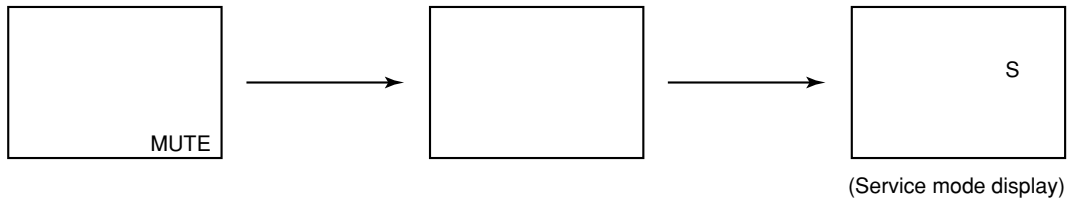

2. DISPLAYING THE ADJUSTMENT MENU

- 1) Press MENU button on TV.

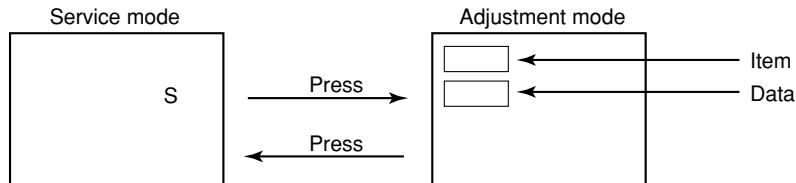

3. KEY FUNCTION IN THE SERVICE MODE

The following key entry during display of adjustment menu provides special functions.

A single horizontal line ON/OFF :	TV (ANT)/VIDEO button (on TV)
Test signal selection :	TV (ANT)/VIDEO button (on Remote)
Selection of the adjustment items :	Channel ▲/▼ (on TV or Remote)
Change of the data value :	Volume ▲/▼ (on TV or Remote)
Adjustment menu mode ON/OFF :	MENU button (on TV)
Initialization of the memory (QA02) :	RECALL+Channel button on TV (▲)
Initialization of the self diagnostic data:	RECALL+Channel button on TV (▼)
“RCUT” selection :	1 button
“GCUT” selection :	2 button
“BCUT” selection :	3 button
“SCNT” selection :	4 button
“COLC” selection :	5 button
“TNTC” selection :	6 button
Self diagnostic display ON/OFF :	9 button

4. SELECTING THE ADJUSTING ITEMS

- 1) Every pressing of CHANNEL ▲ button in the service mode changes the adjustment items in the order of table-2. (▼ button for reverse order)

Refer to table-2 for preset data of adjustment mode.
(See SETTING & ADJUSTING DATA on page 16)

5. ADJUSTING THE DATA

- 1) Pressing of VOLUME ▲ or ▼ button will change the value of data in the range from 00H to FFH. The variable range depends on the adjusting item.

6. EXIT FROM SERVICE MODE

- 1) Pressing POWER button to turn off the TV once.

■ INITIALIZATION OF MEMORY DATA OF QA02

After replacing QA02, the following initialization is required.

1. Enter the service mode, then select any register item.
2. Press and hold the RECALL button on the Remote, then press the CHANNEL ▲ button on the TV. The initialization of QA02 has been completed.
3. Check the picture carefully. If necessary, adjust any adjustment item above.
Perform "Programming Channel Memory" on the owner's manual.

CAUTION: Never attempt to initialize the data unless QA02 has been replaced.

7. TEST SIGNAL SELECTION

- 1) Every pressing of TV/VIDEO button on the Remote Control in the Service mode, changes the built-in test patterns on screen in the following order.

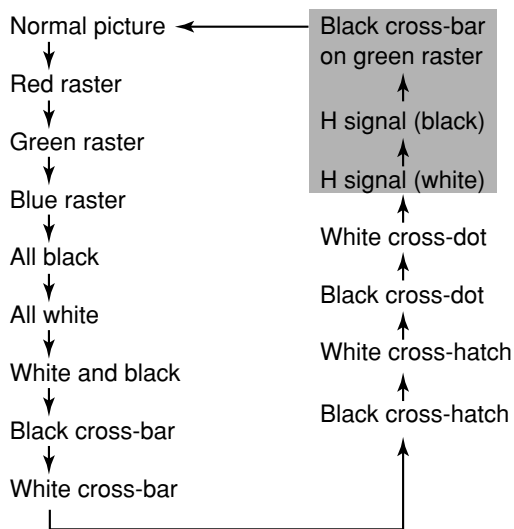

Note: If the video cable is connected to the VIDEO1 INPUT jack, the built-in pattern signals are not displayed.

Signals	Picture
<ul style="list-style-type: none"> • Red raster • Green raster • Blue raster • All Black • All White 	
<ul style="list-style-type: none"> • Black & White 	
<ul style="list-style-type: none"> • Black cross-bar • White cross-bar • Black cross-bar on green raster 	
<ul style="list-style-type: none"> • Black cross-hatch • White cross-hatch 	
<ul style="list-style-type: none"> • Black cross-dot • White cross-dot 	
<ul style="list-style-type: none"> • H signal (white) • H signal (black) 	

* The signals marked with ■ are not usable to display in the Test signal for some model.

DESIGN MODE

1. ENTERING TO DESIGN MODE

- 1) Select the Service mode.
- 2) While pressing RECALL button on Remote and press MENU button on TV.
- 3) Press MENU button on TV.

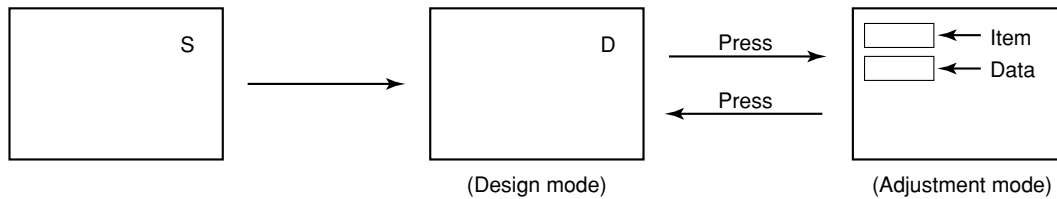

When QA02 is initialized, items "OPT0" and "OPT1" and "OPT2" of DESIGN MODE are set to the data of the representative model of this chassis family.

Therefore, because ON-SCREEN specification remains in the state of the representative of model. This model is required to reset the data of items "OPT0" and "OPT1" and "OPT2".

2. SELECTING THE ADJUSTING ITEMS

Every pressing of CHANNEL ▼ button in the design mode changes the adjustment items in the order of table-3. (▲ button for reverse order)

Refer to table-3 for data of design mode.
(See SETTING & ADJUSTING DATA on page 16)

3. ADJUSTING THE DATA

Pressing of VOLUME ▲ or ▼ button will change the value of data.

ELECTRICAL ADJUSTMENT

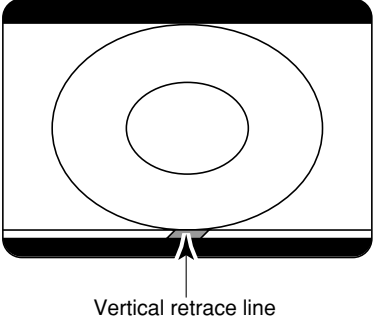
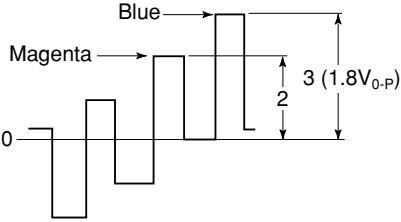
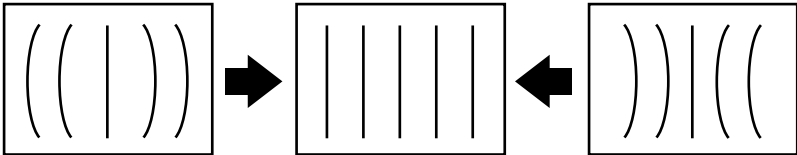
ITEM	ADJUSTMENT PROCEDURE
FOCUS VR ADJ	<ol style="list-style-type: none"> 1. Enter the service mode, then select any register item. 2. Press the TV/VIDEO button on the Remote until the black cross-bar pattern appears on the screen. 3. Adjust the FOCUS control (on T461) for well defined scanning lines on the picture screen.
SUB-BRIGHTNESS (BRTC)	<ol style="list-style-type: none"> 1. Constrict the picture height until the vertical retrace line appears adjusting the HEIGHT control on the MAIN board. 2. Adjust the CONTRAST to the minimum and BRIGHTNESS to the center. 3. Enter the service mode, then select "BRTC" register. 4. Adjust the data value so the belt of vertical retrace line just disappear. 5. Adjust the CONTRAST for the desired contrast. 6. Adjust the HEIGHT control. 
SUB-COLOR (COLC) SUB-TINT (TNTC)	<ol style="list-style-type: none"> 1. Receive color-bar signal from color-bar generator. 2. Press the RESET button. 3. Connect oscilloscope to base of Q906 on CRT-D board. 4. Enter the service mode, then select "COLC". 5. Adjust the SUB-COLOR by pressing the VOLUME ▲ or ▼ button to achieve about $1V_{0-p}$ of blue bar. 6. Select "TNTC" register. 7. Adjust the data value to obtain the blue bar to magenta bar ratio of 3:2 as shown. 8. Select "COLC" register. 9. Adjust the data value to achieve $1.8V_{0-p}$ of blue bar on scope. 10. Check the picture with off-air signal. 
WIDTH (WID)	<ol style="list-style-type: none"> 1. Call up the adjustment mode display, then select the item WID. 2. Press the VOLUME ▲ or ▼ button to get the picture so the left and right edges of raster begins to lack. 3. Press the VOLUME ▲ or ▼ button to advance the data by 7 steps. <p>Note : Check the horizontal picture position is correct.</p>
E-W PARABOLA (DPC)	<ol style="list-style-type: none"> 1. Call up the adjustment mode display, then select the item DPC. 2. Press the TV/VIDEO button on Remote until the cross-hatch pattern appears on the screen. 3. Press the VOLUME ▲ or ▼ button to make vertical lines straight as shown below. 

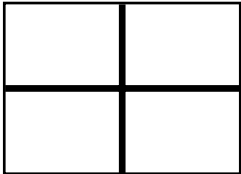
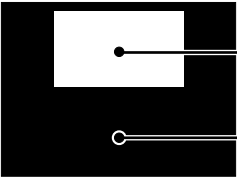
ITEM	ADJUSTMENT PROCEDURE						
HORIZONTAL POSITION (HPOS) VERTICAL POSITION (VPOS)	<ol style="list-style-type: none"> 1. Call up the adjustment mode display, then select the item HPOS or VPOS. 2. Press the TV/VIDEO button on Remote until the white cross-bar or black cross-bar pattern appears on the screen. 3. Adjust the HORIZONTAL and VERTICAL position alternately by pressing the VOLUME ▲ or ▼ button for proper picture position. 4. Check the picture with off-air signal. 						
HEIGHT (HIT)	<ol style="list-style-type: none"> 1. Call up the adjustment mode display, then select the item HIT. 2. Press the VOLUME ▲ or ▼ button to get the picture so the top of raster begins to lack. 3. Press the VOLUME ▲ button to advance the data by 9 steps. <p>Note : Check the vertical picture position is correct.</p>						
WHITE BALANCE (RCUT) (GCUT) (BCUT) (GDRV) (BDRV)	<ol style="list-style-type: none"> 1. Adjust the CONTRAST control to the center, and BRIGHTNESS control to the maximum. 2. Call up the adjustment mode display, and press the TV/VIDEO button on Remote until the white and black pattern appears on the screen. 3. Adjust the following item with the CHANNEL ▲/▼ and VOLUME ▲/▼ buttons. <table style="margin-left: 40px; border: none;"> <tr> <td>RCUT → Data : 40H</td> <td>GDRV → Data : 40H</td> </tr> <tr> <td>GCUT → Data : 40H</td> <td>BDRV → Data : 40H</td> </tr> <tr> <td>BCUT → Data : 40H</td> <td></td> </tr> </table> 4. Press the TV/VIDEO button on TV to display a single horizontal line on the screen. 5. Turn the SCREEN control (FBT) fully counterclockwise and gradually rotate clockwise until the first horizontal line appears slightly on the screen. 6. Press the TV/VIDEO button to display the normal picture. 7. Adjust the remaining two “?CUT” items (CHANNEL ▲/▼ → TV/VIDEO → VOLUME ▲/▼ in order) to obtain the slightly lighted horizontal line in the same levels of three (red, green, blue) colors. The line should be white if the adjustments are proper. <div style="margin-top: 20px;">  <p style="margin-left: 20px;">Bright area Adjust "GDRV" or "BDRV" to be white.</p> <p style="margin-left: 20px;">Dark area Fine adjust "RCUT", "GCUT" or "BCUT" to be black.</p> </div>	RCUT → Data : 40H	GDRV → Data : 40H	GCUT → Data : 40H	BDRV → Data : 40H	BCUT → Data : 40H	
RCUT → Data : 40H	GDRV → Data : 40H						
GCUT → Data : 40H	BDRV → Data : 40H						
BCUT → Data : 40H							
PIP SUB-BRIGHTNESS (PBOF)	<p>Adjust to match the PIP screen to the brightness, white balance and tint of the main picture.</p>						
PIP WHITE BALANCE (PGOF, PROF)							
PIP SUB-TINT (PHUE)							

MTS ADJUSTMENT (FOR N2N, N2F, N2ES, N2S CHASSIS)

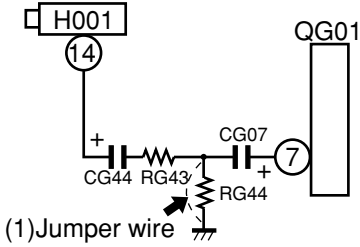
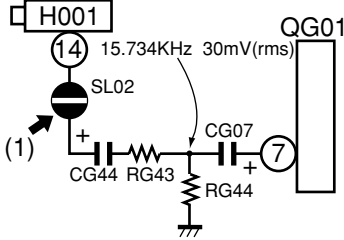
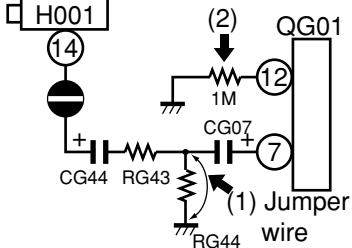
No.	ITEM	INPUT SIGNAL	ADJUSTMENT PROCEDURE
1	ATTENUATOR (ATT)	<ul style="list-style-type: none"> 1kHz 30% mod. → ANT terminal 	<ol style="list-style-type: none"> 1. Connect rms meter to pin 34 of QG01. 2. Display item ATT on screen. 3. Change data by VOLUME ▲/▼ buttons so that the reading of meter becomes value as close as 137mVrms.
2	STEREO VCO (STVC)	<ul style="list-style-type: none"> No signal  <p>(1) Jumper wire</p>	<ol style="list-style-type: none"> 1. Short circuit RG44 with a jumper wire. 2. Display item STVC on screen. 3. Connect frequency counter to pin 34 of QG01. 4. Change data by VOLUME ▲/▼ buttons so that the reading of counter becomes value as close as 15.73kHz. 5. Remove the short jumper from RG44.
3	STEREO FILTER (STRF)	<ul style="list-style-type: none"> 15.734kHz 30mV(rms) → Across Point between CG07 and RG44  <p>(1)</p>	<ol style="list-style-type: none"> 1. Unsolder the solder link SL02. 2. Display item STRF on screen. 3. Connect oscilloscope to pin 34 of QG01. 4. Change data by VOLUME ▲/▼ button to minimize AC output level on scope. 5. Resolder SL02.
4	STEREO SEPARATION (WBAN)	<ul style="list-style-type: none"> STEREO 300Hz (30% mod.) R-channel only → ANT 	<ol style="list-style-type: none"> 1. Display item WBAN on screen. 2. Connect oscilloscope to pin 35 of QG01. 3. Change data by VOLUME ▲/▼ buttons so that 300Hz element on scope becomes minimum.
	(SPEC)	<ul style="list-style-type: none"> STEREO 3kHz (30% mod.) R-channel only → ANT 	<ol style="list-style-type: none"> 1. Display item SPEC on screen. 2. Connect oscilloscope to pin 35 of QG01. 3. Change data by VOLUME ▲/▼ buttons so that 3KHz element on scope becomes minimum.
5	SAP VCO (SAVC)	<ul style="list-style-type: none"> No signal  <p>(1) Jumper wire (2)</p>	<ol style="list-style-type: none"> 1. Shortcircuit RG44 with a short jumper. 2. Connect 1Mohm resistor between pin 12 of QG01 and ground. 3. Display item SAVC on screen. 4. Connect frequency counter to pin 34 of QG01. 5. Change data by VOLUME ▲/▼ buttons so that the reading of counter becomes value as close as 78.67kHz. 6. Remove the short jumper and 1M ohm resistor.

CIRCUIT CHECKS

HIGH VOLTAGE CHECK

CAUTION: There is no HIGH VOLTAGE ADJUSTMENT on this chassis. Checking should be done following the steps below.

1. Connect an accurate high voltage meter to the second anode of the picture tube.
2. Turn on the receiver. Set the BRIGHTNESS and CONTRAST controls to minimum (zero beam current).
3. High voltage must be measured below (B) kV.

Refer to table-1 for high voltage (B).
(See SETTING & ADJUSTING DATA on page 16)

4. Vary the BRIGHTNESS control to both extremes to be sure the high voltage does not exceed the limit under any conditions.

FS CIRCUIT CHECK

The Fail Safe (FS) circuit check is indispensable for the final check in servicing. Checking should be done following the steps below.

1. Turn the receiver on and press the RESET button.
2. Temporarily short TP-(R) and TP-(X) with a jumper wire. Raster and sound will disappear.
3. The receiver must remain in this state even after removing the jumper wire. This is the evidence that the FS circuit is functioning properly.
4. To obtain a picture again, temporarily turn the receiver off and allow the FS circuit more than 5 seconds to reset. Then turn the power switch on to produce a normal picture.

Troubleshooting Guide for Fail Safe Circuit

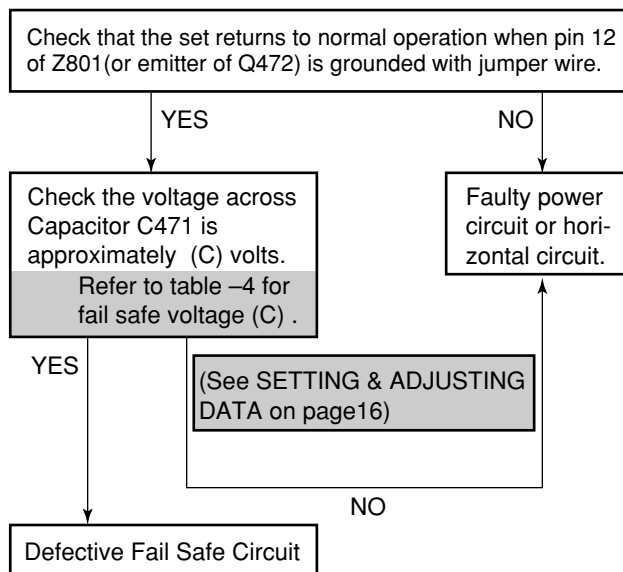

CHAPTER 2 SPECIFIC INFORMATIONS

SETTING & ADJUSTING DATA

【 SAFETY INSTRUCTIONS 】

		32"
HIGH VOLTAGE AT ZERO BEAM:	(A)	31.6kV
MAX HIGH VOLTAGE:	(B)	33.0 kV

Table-1

【 SERVICE MODE 】

ADJUSTING ITEMS AND DATAS IN THE SERVICE MODE:

Item	Name of adjustment	Data	Item	Name of adjustment	Data
RCUT	R CUTOFF	40H	HIT	HEIGHT	1CH
GCUT	G CUTOFF	40H	LIN	V-LINEARITY	08H
BCUT	B CUTOFF	40H	VSC	V-S CORRECTION	02H
GDRV	G DRIVE	40H	VPS	V-SHIFT	01H
BDRV	B DRIVE	40H	VCP	V-COMPENSATION	03H
SCNT	SUB-CONTRAST	0AH	WID	PICTURE WIDTH	26H
BRTC	SUB-BRIGHT	40H	DPC	E-W PARABOLA (DPC)	12H
COLC	SUB-COLOR	3AH	CNR	E-W CORNER	03H
TNTC	SUB-TINT	44H	TRAP	TRAPEZIUM	06H
SAVC	SAP VCO	20H	HCP	H-COMPENSATION	00H
ATT	ATTENUATOR	20H	VFC	V-F CORRECTION	0FH
SAPF	SAP FILTER	88H	PCOL	PIP COLOR	0FH
STVC	STEREO VCO	20H	PHUE	PIP TINT	11H
STRF	STEREO FILTER	20H	DAC	DAC	03H
SPEC	SPECTRAL	20H	PGOF	PIP	36H
WBAN	STEREO SEPARATION	20H	PROF	PIP	17H
HPOS	HORIZ. POSITION	16H	PBOF	PIP	17H
VPOS	VERT. POSITION	03H	RGBB	RGB BRIGHT	0BH

Table-2

【 DESIGN MODE 】

ADJUSTING ITEMS AND DATAS IN THE DESIGN MODE:

Item	Name of adjustment	Preset Data	Data	Remarks
OPT0	OPTION0	20H	24H	
OPT1	OPTION1	84H	04H	
OPT2	OPTION2	01H	43H	

Table-3

【 CIRCUIT CHECKS 】

		32"
FAIL SAFE DET. VOLTAGE	(C)	22.35V

Table-4

LOCATION OF CONTROLS

Front view

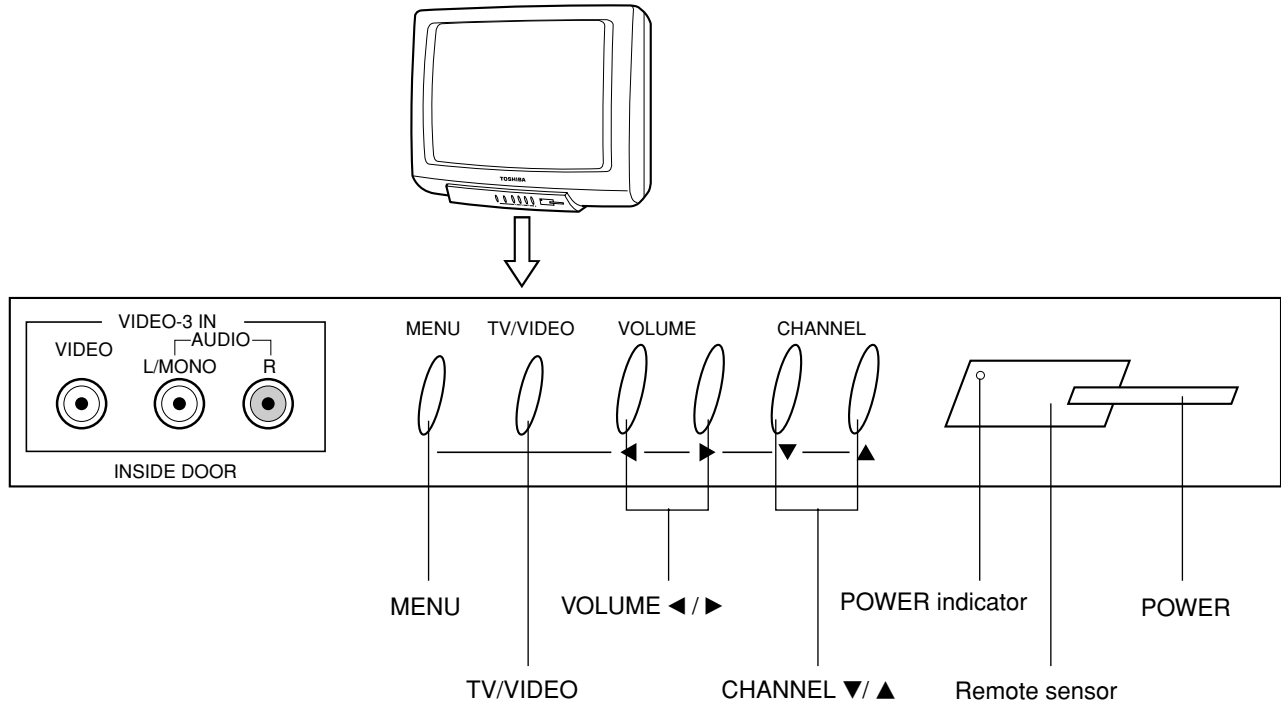

Rear view

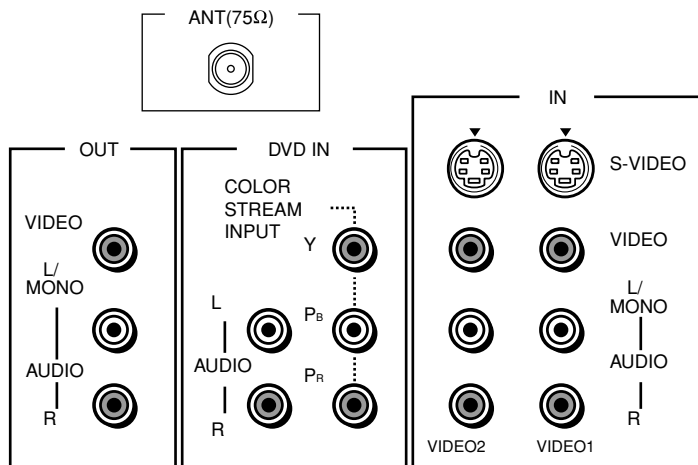

Remote Control

SPECIFIC INFORMATIONS

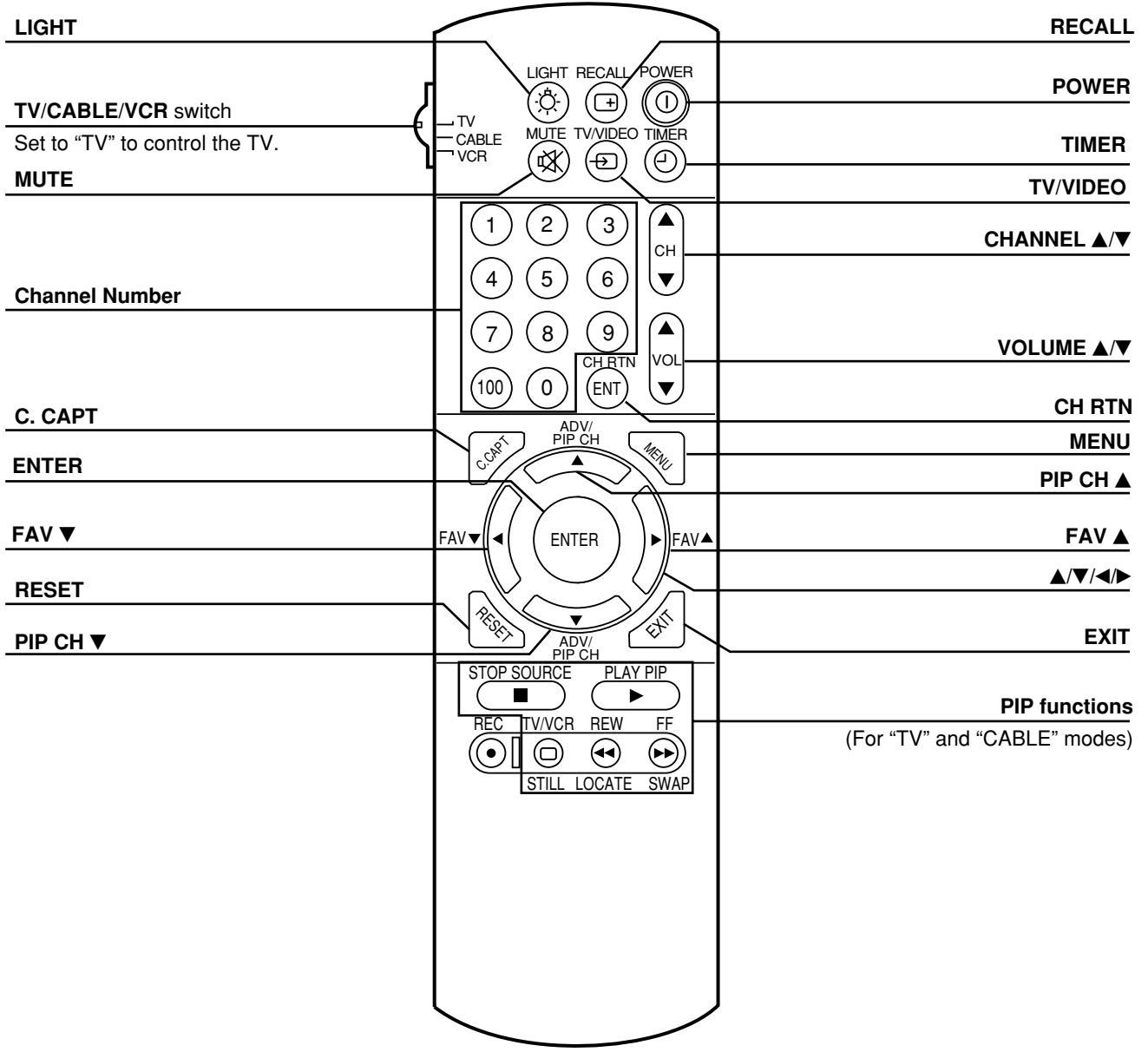

PROGRAMMING CHANNEL MEMORY

The channel memory is the list of TV channel numbers your TV will stop on when you press the CHANNEL ▲ or ▼ button. **First, use the TV/CABLE and CH PROGRAM functions to preset all active channels in your area automatically.** If necessary, arrange the preset channels with the ADD/ERASE functions so that you can tune into only desired channels. **Note:** If you utilize both ANT-1 and ANT-2 terminals for some model, perform programming channels for each input source.

TV/CABLE function

- 1 Press **MENU**, then press ► or ◀ until the SET UP menu appears.
- 2 Press ▼ (or ▲) until “TV/CABLE” is highlighted.
- 3 Press ► or ◀ to highlight either “TV” or “CABLE”, whichever you use.

CH PROGRAM function

- 1 Select “CH PROGRAM” following steps 1 and 2 above.
- 2 Press ► or ◀ to start channel programming. The TV will automatically cycle through all the TV or CABLE channels selected by the TV/CABLE function, and store active channels in the channel memory.
- 3 When channel programming is complete, you will see the message to the right appears.
- 4 Press **CHANNEL ▲** or **▼** to make sure the channel programming has been done properly.

ADD/ERASE function

After performing the CH PROGRAM function, you can add or erase specific channels.

- 1 Select the channel you want to erase using the **CHANNEL ▲** or **▼** button, or select the channel you want to add using the **Channel Number** buttons.
- 2 Press **MENU**, then press ► or ◀ until the SET UP menu appears.
- 3 Press ▼ (or ▲) until “ADD/ERASE” is highlighted.
- 4 Press ► or ◀ :
To erase the channel
Press the button until “ERASE” is highlighted.
To add the channel
Press the button until “ADD” is highlighted.
- 5 Repeat steps 1 to 4 for other channels.

You have now completed the channel programming.

Note: The CHANNEL ▼/▲ buttons on the TV function as the ▼/▲ buttons while a menu is on the screen.

*Please refer to owner's manual in detail.

CHASSIS AND CABINET REPLACEMENT PARTS LIST

WARNING: BEFORE SERVICING THIS CHASSIS, READ THE "X-RAY RADIATION PRECAUTION", "SAFETY PRECAUTION" AND "PRODUCT SAFETY NOTICE" ON PAGE 3 OF THIS MANUAL.

CAUTION: The international hazard symbols " \triangle " in the schematic diagram and the parts list designate components which have special characteristics important for safety and should be replaced only with types identical to those in the original circuit or specified in the parts list. The mounting position of replacements is to be identical with originals. Before replacing any of these components, read carefully the PRODUCT SAFETY NOTICE. Do not degrade the safety of the receiver through improper servicing.

NOTICE:

- The part number must be used when ordering parts, in order to assist in processing, be sure to include the Model number and Description.
- The PC board assembly with * mark is no longer available after the end of the production.

Model : 32A62

Capacitors CD : Ceramic Disk PF : Plastic Film EL : Electrolytic
 Resistors CF : Carbon Film CC : Carbon Composition MF : Metal Film
 OMF : Oxide Metal Film VR : Variable Resistor FR : Fusible Resistor
 (All CD and PF capacitors are $\pm 5\%$, 50V and all resistors, $\pm 5\%$, 1/6W unless otherwise noted.)

SPECIFIC INFORMATIONS

Location No.	Parts No.	Description
CAPACITORS		
C102	24793221	ELECTROLYTIC, 10V 220UF M
C105	24212102	CERAMIC DISC, 50V B 1000PF K
C106	24797479	ELECTROLYTIC, 50V 4.7UF M
C107	24763221	ELECTROLYTIC, 16V 220UF M
C112	24793221	ELECTROLYTIC, 10V 220UF M
C115	24212102	CERAMIC DISC, 50V B 1000PF K
C117	24763221	ELECTROLYTIC, 16V 220UF M
C201	24503041	PLASTIC FILM , 63V 0.1UF J
C204	24797010	ELECTROLYTIC, 50V 1UF M
C205	24794100	ELECTROLYTIC, 16V 10UF M
C207	24436270	CERAMIC DISC, 50V SL 27PFJ
C208	24436270	CERAMIC DISC, 50V SL 27PFJ
C209	24436270	CERAMIC DISC, 50V SL 27PFJ
C213	24503041	PLASTIC FILM , 63V 0.1UF J
C216	24797100	ELECTROLYTIC, 50V 10UF M
C220	24539474	PLASTIC FILM, 50V 0.47UF J
C221	24232103	CERAMIC DISC, 50V F 10000PF Z
C222	24232103	CERAMIC DISC, 50V F 10000PF Z
C223	24232103	CERAMIC DISC, 50V F 10000PF Z
C224	24503041	PLASTIC FILM , 63V 0.1UF J
C225	24503041	PLASTIC FILM , 63V 0.1UF J
C226	24503041	PLASTIC FILM , 63V 0.1UF J
C245	24232103	CERAMIC DISC, 50V F 10000PF Z
C261	24503041	PLASTIC FILM , 63V 0.1UF J
C262	24503041	PLASTIC FILM , 63V 0.1UF J
C263	24503041	PLASTIC FILM , 63V 0.1UF J
C271	24436561	CERAMIC DISC, 50V SL 560PF J
C301	24214471	CERAMIC DISC, 500V B 470PF K
C304	24693473	PLASTIC FILM, 100V 0.047UF J
C305	24617912	ELECTROLYTIC, 50V 2.2UF K 3A LI
C306	24073059	ELECTROLYTIC, 25V 3300UF M 3A
C308	24669221	ELECTROLYTIC, 50V 220UF M 3A
C309	24436101	CERAMIC DISC CC45 SL 50V100PF J
C310	24073094	ELECTROLYTIC, 50V 1000UF M 3A
C312	24503041	PLASTIC FILM , 63V 0.1UF J
C313	24082057	PLASTIC FILM, 100V 220000PF J
C317	24214471	CERAMIC DISC, 500V B 470PF K
C319	24212102	CERAMIC DISC, 50V B 1000PF K

Location No.	Parts No.	Description
C320	24669101	ELECTROLYTIC, 50V 100UF M 3A
C323	24567474	PLASTIC FILM, 50V 0.47UF J
C324	24503037	MT PLA CAP 63V 0.047UF J
C325	24503039	MT PLA CAP 63V 0.068UF J
C326	24503041	PLASTIC FILM , 63V 0.1UF J
C327	24617915	ELECTROLYTIC, 50V 1UF K 3A LI
C337	24797229	ELECTROLYTIC, 50V 2.2UF M
C360	24793221	ELECTROLYTIC, 10V 220UF M
C361	24794101	ELECTROLYTIC, 16V 100UF M
C370	24668101	ELECTROLYTIC, 35V 100UF M 3A
C371	24668100	ELECTROLYTIC, 35V 10UF M 3A
C400	24503041	PLASTIC FILM , 63V 0.1UF J
C403	24591103	PLASTIC FILM, 50V 0.01UF J
C404	24797010	ELECTROLYTIC, 50V 1UF M
C407	24503041	PLASTIC FILM , 63V 0.1UF J
C408	24591273	PLASTIC FILM, 50V 0.027UF J
C409	24763221	ELECTROLYTIC, 16V 220UF M
C410	24232103	CERAMIC DISC, 50V F 10000PF Z
C413	24214821	CERAMIC DISC, 500V B 820PF K
C415	24539224	PLASTIC FILM, 50V 0.22UF J
C416	24678229	ELECTROLYTIC, 200V 2.2UF M 3A
C417	24214391	CERAMIC DISC, 500V B 390PF K
C430	24232103	CERAMIC DISC, 50V F 10000PF Z
C431	24794101	ELECTROLYTIC, 16V 100UF M
C439	24503125	PLASTIC CAP T 400V 753J
C441	24082925	PLASTIC FILM CF92 T 315V 0.62UF J
\triangle C442	24082924	PLASTIC FILM CF92 T 315V 0.56UF J
C443	24082963	PLASTIC FILM, 1500VH 9100PF H
\triangle C444	24082964	PLASTIC FILM, 1500VH 10000PF H
C445	24828563	PLASTIC FILM, 200V 56000PF J
C446	24679100	ELECTROLYTIC, 250V 10UF M 3A
C447	24214471	CERAMIC DISC, 500V B 470PF K
C448	24640908	ELECTROLYTIC, 160V 33UF M 3A LI
C449	24666102	ELECTROLYTIC, 16V 1000UF M 3A
C451	24085981	ELEC. NONPOLAR CE04J 16V 10UF M 11L NP
C453	24092344	CERAMIC DISC, 2KV 820PF K
C457	24591332	PLASTIC FILM, 50V 3300PF J
C457	24591562	PLASTIC FILM, 50V 5600PF J
C463	24212222	CERAMIC DISK CK45 B 50V 2200PF K

Location No.	Parts No.	Description
C464	24640872	ELECTROLYTIC CE04R 100V 10UF M 3A
△ C467	24082095	PLASTIC FILM, 630V 0.018UF
C469	24082095	PLASTIC FILM, 630V 0.018UF
C471	24797479	ELECTROLYTIC, 50V 4.7UF M
C473	24797479	ELECTROLYTIC, 50V 4.7UF M
C474	24797479	ELECTROLYTIC, 50V 4.7UF M
C480	24747220	ELECTROLYTIC CE04HS 50V 22UF M 7L 3A
C481	24503049	PLASTIC FILM, 63V 0.47UF J
C482	24797478	ELECTROLYTIC, 50V 0.47UF M
C499	24212102	CERAMIC DISC, 50V B 1000PF K
C501	24436102	CERAMIC DISC, 50V SL 1000PF J
C504	24591222	PLASTIC FILM, 50V 2200PF J
C505	24353120	CERAMIC DISC, 50V CH 12PF J
C510	24763101	ELECTROLYTIC, 16V 100UF M
C511	24232103	CERAMIC DISC, 50V F 10000PF Z
C512	24206228	ELECTROLYTIC, 50V 0.22UF M 7L 3A
C582	24232103	CERAMIC DISC, 50V F 10000PF Z
C583	24762471	ELECTROLYTIC, 10V 470UF M
C612	24794470	ELECTROLYTIC, 16V 47UF M
C613	24232103	CERAMIC DISC, 50V F 10000PF Z
C661	24212102	CERAMIC DISC, 50V B 1000PF K
C662	24212102	CERAMIC DISC, 50V B 1000PF K
C663	24666100	ELECTROLYTIC, 10V 10UF M 3A
C671	24795470	ELECTROLYTIC, 25V 47UF M
C672	24795470	ELECTROLYTIC, 25V 47UF M
C673	24669229	ELECTROLYTIC, 50V 2.2UF M 3A
C674	24669479	ELECTROLYTIC, 50V 4.7UF M 3A
C675	24669479	ELECTROLYTIC, 50V 4.7UF M 3A
C676	24503041	PLASTIC FILM , 63V 0.1UF J
C677	24503041	PLASTIC FILM , 63V 0.1UF J
C678	24669229	ELECTROLYTIC, 50V 2.2UF M 3A
C679	24795470	ELECTROLYTIC, 25V 47UF M
C681	24667102	ELECTROLYTIC, 25V 1000UF M 3A
C682	24668471	ELECTROLYTIC, 35V 470UF M 3A
C683	24667102	ELECTROLYTIC, 25V 1000UF M 3A
C801	24503002	PLASTIC FILM, AC275V 0.22UF M
C802	24503001	PLASTIC FILM, AC275V 0.1UF M
C805	24092623	CERAMIC DISC CKS45F 250V 10000PFZ
C806	24092623	CERAMIC DISC CKS45F 250V 10000PFZ
C808	24669470	ELECTROLYTIC, 50V 47UF M 3A
C810	24086061	ELECTROLYTIC, 200V 470UF M 3F
C811	24092583	CERAMIC DISC, AC250V E 2200PF M
C812	24092583	CERAMIC DISC, AC250V E 2200PF M
C813	24092583	CERAMIC DISC, AC250V E 2200PF M
C817	24092339	CERAMIC DISC, 2KV 330PF K
C818	24082402	PLASTIC FILM, 1250VH 2200PF H
C821	24214471	CERAMIC DISC, 500V B 470PF K
C823	24212471	CERAMIC DISC, 50V B 470PF K
C829	24591222	PLASTIC FILM, 50V 2200PF J
C830	24503047	PLASTIC FILM, 63V 0.33UF J
C831	24503047	PLASTIC FILM, 63V 0.33UF J
C832	24794470	ELECTROLYTIC, 16V 47UF M
C840	24795221	ELECTROLYTIC, 25V 220UF M
C842	24792101	ELECTROLYTIC, 6.3V 100UF M
C843	24797479	ELECTROLYTIC, 50V 4.7UF M
C884	24640018	ELECTROLYTIC, 160V 220UF
C886	24214471	CERAMIC DISC, 500V B 470PF K
C889	24796222	ELECTROLYTIC, 35V 2200UF M
C893	24092339	CERAMIC DISC, 2KV 330PF K
C898	24503047	PLASTIC FILM, 63V 0.33UF J
C902	24092345	CERAMIC DISC, 2KV 0.001UF K
C904	24436391	CERAMIC DISC, 50V SL 390PF J
C905	24436391	CERAMIC DISC, 50V SL 390PF J
C907	24436391	CERAMIC DISC, 50V SL 390PF J
C909	24679220	ELECTROLYTIC, 250V 22UF M 3A

Location No.	Parts No.	Description
C910	24797478	ELECTROLYTIC, 50V 0.47UF M
C911	24794100	ELECTROLYTIC, 16V 10UF M
C912	24763471	ELECTROLYTIC, 16V 470UF M
C913	24794100	ELECTROLYTIC, 16V 10UF M
C914	24232103	CERAMIC DISC, 50V F 10000PF Z
C920	24214101	CERAMIC DISC, 500V B 100PF K
C921	24232103	CERAMIC DISC, 50V F 10000PF Z
C922	24232103	CERAMIC DISC, 50V F 10000PF Z
CA13	24436470	CERAMIC DISC, 50V SL 47PF J
CA33	24232103	CERAMIC DISC, 50V F 10000PF Z
CA36	24212101	CERAMIC DISC, 50V B 100PF K
CA37	24212101	CERAMIC DISC, 50V B 100PF K
CA38	24212101	CERAMIC DISC, 50V B 100PF K
CA42	24794100	ELECTROLYTIC, 16V 10UF M
CA43	24232103	CERAMIC DISC, 50V F 10000PF Z
CA44	24232103	CERAMIC DISC, 50V F 10000PF Z
CA68	24794100	ELECTROLYTIC, 16V 10UF M
CA69	24232103	CERAMIC DISC, 50V F 10000PF Z
CB01	24797470	ELECTROLYTIC, 50V 47UF M
CB41	24763221	ELECTROLYTIC, 16V 220UF M
CB48	24436101	CERAMIC DISC CC45 SL 50V100PF J
CG02	24794220	ELECTROLYTIC, 16V 22UF M
CG03	24503041	PLASTIC FILM , 63V 0.1UF J
CG05	24797010	ELECTROLYTIC, 50V 1UF M
CG06	24797479	ELECTROLYTIC, 50V 4.7UF M
CG07	24797229	ELECTROLYTIC, 50V 2.2UF M
CG08	24503037	MT PLA CAP 63V 0.047UF J
CG09	24797478	ELECTROLYTIC, 50V 0.47UF M
CG10	24503041	PLASTIC FILM , 63V 0.1UF J
CG12	24206108	ELECTROLYTIC, 50V 0.1UF M 7L 3A
CG13	24704335	TA SOLID ELEC.CS15H 16V 3.3UF M
CG14	24797010	ELECTROLYTIC, 50V 1UF M
CG16	24704106	TA SOLID ELEC.CS15H 16V 10UF M
CG17	24797010	ELECTROLYTIC, 50V 1UF M
CG18	24797010	ELECTROLYTIC, 50V 1UF M
CG19	24797479	ELECTROLYTIC, 50V 4.7UF M
CG20	24797010	ELECTROLYTIC, 50V 1UF M
CG27	24591223	PLASTIC FILM, 50V 0.022MF J
CG28	24797229	ELECTROLYTIC, 50V 2.2UF M
CG29	24591102	PLASTIC FILM, 50V 1000PF J
CG30	24206108	ELECTROLYTIC, 50V 0.1UF M 7L 3A
CG31	24797229	ELECTROLYTIC, 50V 2.2UF M
CG32	24591102	PLASTIC FILM, 50V 1000PF J
CG33	24206108	ELECTROLYTIC, 50V 0.1UF M 7L 3A
CG37	24206229	ELECTROLYTIC, 50V 2.2UF M 7L 3A
CG38	24206229	ELECTROLYTIC, 50V 2.2UF M 7L 3A
CG42	24797010	ELECTROLYTIC, 50V 1UF M
CG44	24794100	ELECTROLYTIC, 16V 10UF M
CG46	24794101	ELECTROLYTIC, 16V 100UF M
CM51	24503041	PLASTIC FILM , 63V 0.1UF J
CM58	24503041	PLASTIC FILM , 63V 0.1UF J
CR01	24503041	PLASTIC FILM , 63V 0.1UF J
CR02	24503041	PLASTIC FILM , 63V 0.1UF J
CR03	24503041	PLASTIC FILM , 63V 0.1UF J
CS02	24797229	ELECTROLYTIC, 50V 2.2UF M
CS04	24797229	ELECTROLYTIC, 50V 2.2UF M
CS08	24797229	ELECTROLYTIC, 50V 2.2UF M
CS10	24797229	ELECTROLYTIC, 50V 2.2UF M
CS14	24797229	ELECTROLYTIC, 50V 2.2UF M
CS16	24797229	ELECTROLYTIC, 50V 2.2UF M
CS25	24797229	ELECTROLYTIC, 50V 2.2UF M
CS26	24797229	ELECTROLYTIC, 50V 2.2UF M
CS40	24797010	ELECTROLYTIC, 50V 1UF M
CS42	24797010	ELECTROLYTIC, 50V 1UF M
CS43	24436331	CERAMIC DISC, 50V SL 330PF J

Location No.	Parts No.	Description
CS44	24436331	CERAMIC DISC, 50V SL 330PF J
CS45	24436331	CERAMIC DISC, 50V SL 330PF J
CS46	24436331	CERAMIC DISC, 50V SL 330PF J
CS47	24436331	CERAMIC DISC, 50V SL 330PF J
CS48	24436331	CERAMIC DISC, 50V SL 330PF J
CS49	24436331	CERAMIC DISC, 50V SL 330PF J
CS50	24436331	CERAMIC DISC, 50V SL 330PF J
CS51	24212102	CERAMIC DISC, 50V B 1000PF K
CS52	24212102	CERAMIC DISC, 50V B 1000PF K
CS70	24794220	ELECTROLYTIC, 16V 22UF M
CS71	24794220	ELECTROLYTIC, 16V 22UF M
CS115	24797010	ELECTROLYTIC, 50V 1UF M
CS116	24797010	ELECTROLYTIC, 50V 1UF M
CS118	24794470	ELECTORLYTIC, 16V 47UF M
CS120	24797010	ELECTROLYTIC, 50V 1UF M
CS625	24797479	ELECTROLYTIC, 50V 4.7UF M
CS626	24797479	ELECTROLYTIC, 50V 4.7UF M
CS627	24797479	ELECTROLYTIC, 50V 4.7UF M
CS628	24797479	ELECTROLYTIC, 50V 4.7UF M
CS630	24794101	ELECTROLYTIC, 16V 100UF M
CV03	24206108	ELECTROLYTIC, 50V 0.1UF M 7L 3A
CV05	24232103	CERAMIC DISC, 50V F 10000PF Z
CV09	24503041	PLASTIC FILM , 63V 0.1UF J
CV13	24206108	ELECTROLYTIC, 50V 0.1UF M 7L 3A
CV15	24232103	CERAMIC DISC, 50V F 10000PF Z
CV24	24591473	PLASTIC FILM, 50V 0.047UF J
CV25	24794220	ELECTROLYTIC, 16V 22UF M
CV27	24206108	ELECTROLYTIC, 50V 0.1UF M 7L 3A
CV29	24232103	CERAMIC DISC, 50V F 10000PF Z
CV31	24503041	PLASTIC FILM , 63V 0.1UF J
CV38	24763471	ELECTROLYTIC, 16V 470UF M
CV39	24232103	CERAMIC DISC, 50V F 10000PF Z
CV41	24591223	PLASTIC FILM, 50V 0.022MF J
CV45	24232103	CERAMIC DISC, 50V F 10000PF Z
CV46	24794101	ELECTROLYTIC, 16V 100UF M
CV47	24794100	ELECTROLYTIC, 16V 10UF M
CV48	24232103	CERAMIC DISC, 50V F 10000PF Z
CV49	24794100	ELECTROLYTIC, 16V 10UF M
CV60	24763471	ELECTROLYTIC, 16V 470UF M
CV61	24762471	ELECTROLYTIC, 10V 470UF M
CZ03	24092743	CERAMIC CHIP, 10V F 470NF Z
CZ05	24109103	CERAMIC CHIP, 50V B 10000PF K
CZ07	24092730	CERAMIC CHIP, 16V B 0.1UF K
CZ09	24105220	CERAMIC CHIP, 50V CH 22PF J
CZ10	24105100	CERAMIC CHIP, 50V CH 10PF D
CZ11	24105220	CERAMIC CHIP, 50V CH 22PF J
CZ12	24109103	CERAMIC CHIP, 50V B 10000PF K
CZ13	24109103	CERAMIC CHIP, 50V B 10000PF K
CZ14	24203100	ELECTORLYTIC, 16V 10UF M 7L 3A
CZ17	24109103	CERAMIC CHIP, 50V B 10000PF K
CZ19	24105181	CERAMIC CHIP, 50V CH 180PF J
CZ20	24109103	CERAMIC CHIP, 50V B 10000PF K
CZ21	24109122	CERAMIC CHIP CC73B 50V 1200PF K
CZ22	24203100	ELECTORLYTIC, 16V 10UF M 7L 3A
CZ23	24109103	CERAMIC CHIP, 50V B 10000PF K
CZ24	24109103	CERAMIC CHIP, 50V B 10000PF K
CZ25	24203100	ELECTORLYTIC, 16V 10UF M 7L 3A
CZ26	24109103	CERAMIC CHIP, 50V B 10000PF K
CZ28	24109103	CERAMIC CHIP, 50V B 10000PF K
CZ29	24109103	CERAMIC CHIP, 50V B 10000PF K
CZ30	24203100	ELECTORLYTIC, 16V 10UF M 7L 3A
CZ31	24092730	CERAMIC CHIP, 16V B 0.1UF K
CZ32	24105150	CERAMIC CHIP, 50V CH 15PF J
CZ33	24105390	CERAMIC CHIP, 50V CH 39PF J
CZ34	24105150	CERAMIC CHIP, 50V CH 15PF J

Location No.	Parts No.	Description
CZ35	24105390	CERAMIC CHIP, 50V CH 39PF J
CZ37	24203100	ELECTORLYTIC, 16V 10UF M 7L 3A
CZ38	24203100	ELECTORLYTIC, 16V 10UF M 7L 3A
CZ41	24105470	CERAMIC CHIP, 50V CH 47PF J
CZ42	24105470	CERAMIC CHIP, 50V CH 47PF J
CZ45	24105100	CERAMIC CHIP, 50V CH 10PF D
RESISTORS		
R101	24382223	OXIDE METAL FILM, 1W 22K OHM J
R201	24366102	CARBON FILM, 1/6W 1K OHM J
R202	24366102	CARBON FILM, 1/6W 1K OHM J
R203	24366474	CARBON FILM, 1/6W 470K OHM J
R207	24366101	CARBON FILM, 1/6W 100 OHM J
R208	24366101	CARBON FILM, 1/6W 100 OHM J
R209	24366101	CARBON FILM, 1/6W 100 OHM J
R216	24366223	CARBON FILM, 1/6W 22K OHM J
R223	24366102	CARBON FILM, 1/6W 1K OHM J
R228	24366473	CARBON FILM, 1/6W 47K OHM J
R238	24366473	CARBON FILM, 1/6W 47K OHM J
R240	24366562	CARBON FILM, 1/6W 5.6K OHM J
R245	24366104	CARBON FILM, 1/6W 100K OHM J
R261	24366472	CARBON FILM, 1/6W 4.7K OHM J
R262	24366102	CARBON FILM, 1/6W 1K OHM J
R263	24366472	CARBON FILM, 1/6W 4.7K OHM J
R264	24366102	CARBON FILM, 1/6W 1K OHM J
R265	24366472	CARBON FILM, 1/6W 4.7K OHM J
R266	24366102	CARBON FILM, 1/6W 1K OHM J
R271	24366471	CARBON FILM, 1/6W 470 OHM J
R272	24366222	CARBON FILM, 1/6W 2.2K OHM J
R275	24366103	CARBON FILM, 1/6W 10K OHM J
R303	24321109	OXIDE METAL FILM, 1/2W 1 OHM J
R304	24366563	CARBON FILM, 1/6W 56K OHM J
R305	24322758	OXIDE METAL FILM, 1W 0.75 OHM J
R306	24366243	CARBON FILM, 1/6W 24K OHM J
R307	24366624	CARBON FILM, 1/6W 620K OHM J
R311	24366332	CARBON FILM, 1/6W 3.3K OHM J
R312	24366153	CARBON FILM, 1/6W 15K OHM J
R313	24366153	CARBON FILM, 1/6W 15K OHM J
R315	24366184	CARBON FILM, 1/6W 180K OHM J
R315	24366394	CARBON FILM, 1/6W 390K OHM J
R316	24366154	CARBON FILM, 1/6W 150K OHM J
R317	24366102	CARBON FILM, 1/6W 1K OHM J
R327	24339479	OXIDE METAL FILM, 2W 4.7 OHM J
R328	24366684	CARBON FILM, 1/6W 680K OHM J
R332	24366473	CARBON FILM, 1/6W 47K OHM J
R336	24382221	OXIDE METAL FILM, 2W 220 OHM J
R345	24382102	OXIDE METAL FILM, 1W 1K OHM J
R360	24366104	CARBON FILM, 1/6W 100K OHM J
R368	24545479	FUSIBLE, 1/4W 4.7 OHM J
R369	24366391	CARBON FILM, 1/6W 390 OHM J
R370	24321109	OXIDE METAL FILM, 1/2W 1 OHM J
R371	24366103	CARBON FILM, 1/6W 10K OHM J
R372	24366392	CARBON FILM, 1/6W 3.9K OHM J
R373	24366102	CARBON FILM, 1/6W 1K OHM J
R374	24366163	CARBON FILM, 1/6W 16K OHM J
R401	24366391	CARBON FILM, 1/6W 390 OHM J
R403	24366622	CARBON FILM, 1/6W 6.2K OHM J
R405	24382682	OXIDE METAL FILM, 1W 6.8K OHM J
R406	24366273	CARBON FILM, 1/6W 27K OHM J
R407	24366103	CARBON FILM, 1/6W 10K OHM J
R408	24366472	CARBON FILM, 1/6W 4.7K OHM J
R410	24366271	CARBON FILM, 1/6W 270 OHM J
R411	24366561	CARBON FILM, 1/6W 560 OHM J
R415	24553272	OXIDE METAL FILM, 1W 2.7K OHM J
R416	24510332	CERAMIC COVERED, 5W 3.3K OHM J

Location No.	Parts No.	Description
R418	24383181	OXIDE METAL FILM, 2W 180 OHM J
R430	24366102	CARBON FILM, 1/6W 1K OHM J
R431	24366103	CARBON FILM, 1/6W 10K OHM J
R432	24366202	CARBON FILM, 1/6W 2K OHM J
R433	24366102	CARBON FILM, 1/6W 1K OHM J
R441	24532102	FUSIBLE, 1W 1K OHM J
R443	24382153	OXIDE METAL FILM, 1W 15K OHM J
R448	24338228	OXIDE METAL FILM, 1W 0.22 OHM J
R450	24366103	CARBON FILM, 1/6W 10K OHM J
R456	24366103	CARBON FILM, 1/6W 10K OHM J
R457	24366104	CARBON FILM, 1/6W 100K OHM J
R458	24366104	CARBON FILM, 1/6W 100K OHM J
R463	24322479	METAL FILM, 1W 4R7 J
R472	24382270	OXIDE FILM, 1W 27 J
△ R475	24366391	CARBON FILM, 1/6W 390 OHM J
R476	24366823	CARBON FILM, 1/6W 82K OHM J
R477	24366273	CARBON FILM, 1/6W 27K OHM J
△ R478	24327133	METAL FILM, 1/4W 13K OHM F
R480	24366123	CARBON FILM, 1/6W 12K OHM J
R481	24366333	CARBON FILM, 1/6W 33K OHM J
△ R482	24327472	METAL FILM, 1/4W 4R7K F
R483	24366103	CARBON FILM, 1/6W 10K OHM J
R485	24338568	OXIDE METAL FILM, 1W 0.56 OHM J
R486	24552820	OXIDE METAL FILM, 1/2W 82 OHM J
R487	24552301	OXIDE METAL FILM, 1/2W 300 OHM J
R488	24327183	METAL FILM, 1/4W 18K OHM F
R489	24327183	METAL FILM, 1/4W 18K OHM F
R490	24366102	CARBON FILM, 1/6W 1K OHM J
R493	24366102	CARBON FILM, 1/6W 1K OHM J
R494	24366471	CARBON FILM, 1/6W 470 OHM J
R495	24366560	CARBON FILM, 1/6W 56 OHM J
R501	24366153	CARBON FILM, 1/6W 15K OHM J
R502	24366101	CARBON FILM, 1/6W 100 OHM J
R503	24366101	CARBON FILM, 1/6W 100 OHM J
R508	24366102	CARBON FILM, 1/6W 1K OHM J
R509	24366102	CARBON FILM, 1/6W 1K OHM J
R510	24366102	CARBON FILM, 1/6W 1K OHM J
R511	24366101	CARBON FILM, 1/6W 100 OHM J
R612	24366103	CARBON FILM, 1/6W 10K OHM J
R613	24366222	CARBON FILM, 1/6W 2.2K OHM J
R614	24366102	CARBON FILM, 1/6W 1K OHM J
R661	24366562	CARBON FILM, 1/6W 5.6K OHM J
R662	24366562	CARBON FILM, 1/6W 5.6K OHM J
R663	24366182	CARBON FILM, 1/6W 1.8K OHM J
R664	24366182	CARBON FILM, 1/6W 1.8K OHM J
R667	24366223	CARBON FILM, 1/6W 22K OHM J
R668	24366103	CARBON FILM, 1/6W 10K OHM J
R669	24366103	CARBON FILM, 1/6W 10K OHM J
R676	24366229	CARBON FILM, 1/6W 2.2 OHM J
R677	24366229	CARBON FILM, 1/6W 2.2 OHM J
R808	24019493	THERMISTOR, PTC THERMISTOR AC140V 1R5 M
R810	24569828	CERAMIC COVERED, G 10W 0.82 K
R814	24366103	CARBON FILM, 1/6W 10K OHM J
R818	24510150	CERAMIC COVERED, G 5W 15 J
R820	24322208	OXIDE METAL FILM, 1W 0.2 OHM J
R821	24321829	METAL FILM, 1/2W 8R2 J
R821	24366129	CARBON RES G 1/6W 1R2J
R823	24552332	OXIDE METAL FILM, 1/2W 3.3K OHM J
R829	24004945	METAL FILM, 1W R18 J
R830	24548569	FUSIBLE, 2W 5R6 J
R831	24366561	CARBON FILM, 1/6W 560 OHM J
R835	24552471	OXIDE METAL FILM, 1/2W 470 OHM J
R861	24366104	CARBON FILM, 1/6W 100K OHM J
R862	24366104	CARBON FILM, 1/6W 100K OHM J

Location No.	Parts No.	Description
R898	24010001	CARBON FILM, 1/2W 3.9M J
R901	24552102	OXIDE METAL FILM, 1/2W 1K OHM J
R902	24552102	OXIDE METAL FILM, 1/2W 1K OHM J
R903	24552102	OXIDE METAL FILM, 1/2W 1K OHM J
R904	24366103	CARBON FILM, 1/6W 10K OHM J
R905	24366101	CARBON FILM, 1/6W 100 OHM J
R911	24366150	CARBON FILM, 1/6W 15 OHM J
R914	24366561	CARBON FILM, 1/6W 560 OHM J
R915	24366301	CARBON FILM, 1/6W 300 OHM J
R917	24366102	CARBON FILM, 1/6W 1K OHM J
R918	24366820	CARBON FILM, 1/6W 82 OHM J
R920	24000880	FUSIBLE, 1W 5.1 OHM J
R921	24366561	CARBON FILM, 1/6W 560 OHM J
R922	24366301	CARBON FILM, 1/6W 300 OHM J
R924	24366820	CARBON FILM, 1/6W 82 OHM J
R925	24366102	CARBON FILM, 1/6W 1K OHM J
R928	24366561	CARBON FILM, 1/6W 560 OHM J
R929	24366301	CARBON FILM, 1/6W 300 OHM J
R930	24366820	CARBON FILM, 1/6W 82 OHM J
R932	24366272	CARBON FILM, 1/6W 2.7K OHM J
R934	24366391	CARBON FILM, 1/6W 390 OHM J
R935	24366821	CARBON FILM, 1/6W 820 OHM J
R936	24366750	CARBON FILM, 1/6W 75 OHM J
R937	24366102	CARBON FILM, 1/6W 1K OHM J
R939	24366101	CARBON FILM, 1/6W 100 OHM J
R942	24366562	CARBON FILM, 1/6W 5.6K OHM J
R943	24366562	CARBON FILM, 1/6W 5.6K OHM J
R944	24366562	CARBON FILM, 1/6W 5.6K OHM J
R960	24383153	OXIDE METAL FILM, 2W 15K OHM J
R961	24383153	OXIDE METAL FILM, 2W 15K OHM J
R962	24383153	OXIDE METAL FILM, 2W 15K OHM J
R977	24366122	CARBON FILM, 1/6W 1.2K OHM J
R980	24366471	CARBON FILM, 1/6W 470 OHM J
R981	24366821	CARBON FILM, 1/6W 820 OHM J
R982	24366103	CARBON FILM, 1/6W 10K OHM J
R983	24366222	CARBON FILM, 1/6W 2.2K OHM J
R984	24367152	CARBON FILM, 1/6W 1.5K OHM G
R985	24367471	CARBON FILM, 1/6W 470 OHM G
R986	24367681	CARBON FILM, 1/6W 680 OHM G
R987	24367681	CARBON FILM, 1/6W 680 OHM G
R988	24367472	CARBON FILM, 1/6W 4.7K OHM G
R989	24367472	CARBON FILM, 1/6W 4.7K OHM G
R990	24366222	CARBON FILM, 1/6W 2.2K OHM J
R991	24367681	CARBON FILM, 1/6W 680 OHM G
R4460	24366102	CARBON FILM, 1/6W 1K OHM J
R4461	24366102	CARBON FILM, 1/6W 1K OHM J
R4462	24366133	CARBON FILM, 1/6W 13K OHM J
R4463	24366682	CARBON FILM, 1/6W 6.8K OHM J
R4465	24366223	CARBON FILM, 1/6W 22K OHM J
R4466	24366103	CARBON FILM, 1/6W 10K OHM J
R4467	24366103	CARBON FILM, 1/6W 10K OHM J
R4468	24366472	CARBON FILM, 1/6W 4.7K OHM J
R4760	24366102	CARBON FILM, 1/6W 1K OHM J
R4761	24366102	CARBON FILM, 1/6W 1K OHM J
R4762	24366332	CARBON FILM, 1/6W 3.3K OHM J
R4765	24366221	CARBON FILM, 1/6W 220 OHM J
R4767	24366222	CARBON FILM, 1/6W 2.2K OHM J
R4770	24366392	CARBON FILM, 1/6W 3.9K OHM J
R4771	24366103	CARBON FILM, 1/6W 10K OHM J
RA02	24366102	CARBON FILM, 1/6W 1K OHM J
RA03	24366102	CARBON FILM, 1/6W 1K OHM J
RA04	24366102	CARBON FILM, 1/6W 1K OHM J
RA06	24366102	CARBON FILM, 1/6W 1K OHM J
RA07	24366102	CARBON FILM, 1/6W 1K OHM J
RA08	24366102	CARBON FILM, 1/6W 1K OHM J

Location No.	Parts No.	Description
RA09	24366102	CARBON FILM, 1/6W 1K OHM J
RA10	24366103	CARBON FILM, 1/6W 10K OHM J
RA13	24366103	CARBON FILM, 1/6W 10K OHM J
RA14	24366102	CARBON FILM, 1/6W 1K OHM J
RA15	24366102	CARBON FILM, 1/6W 1K OHM J
RA16	24366102	CARBON FILM, 1/6W 1K OHM J
RA17	24366102	CARBON FILM, 1/6W 1K OHM J
RA18	24366102	CARBON FILM, 1/6W 1K OHM J
RA20	24366221	CARBON FILM, 1/6W 220 OHM J
RA21	24366102	CARBON FILM, 1/6W 1K OHM J
RA22	24366331	CARBON FILM, 1/6W 330 OHM J
RA23	24366331	CARBON FILM, 1/6W 330 OHM J
RA24	24366331	CARBON FILM, 1/6W 330 OHM J
RA25	24366331	CARBON FILM, 1/6W 330 OHM J
RA26	24366102	CARBON FILM, 1/6W 1K OHM J
RA27	24366102	CARBON FILM, 1/6W 1K OHM J
RA33	24366103	CARBON FILM, 1/6W 10K OHM J
RA34	24366471	CARBON FILM, 1/6W 470 OHM J
RA35	24366102	CARBON FILM, 1/6W 1K OHM J
RA36	24366103	CARBON FILM, 1/6W 10K OHM J
RA37	24366331	CARBON FILM, 1/6W 330 OHM J
RA38	24366331	CARBON FILM, 1/6W 330 OHM J
RA40	24366101	CARBON FILM, 1/6W 100 OHM J
RA41	24366101	CARBON FILM, 1/6W 100 OHM J
RA61	24366103	CARBON FILM, 1/6W 10K OHM J
RA62	24366103	CARBON FILM, 1/6W 10K OHM J
RA67	24366472	CARBON FILM, 1/6W 4.7K OHM J
RA68	24366472	CARBON FILM, 1/6W 4.7K OHM J
RA71	24366683	CARBON FILM, 1/6W 68K OHM J
RA72	24366223	CARBON FILM, 1/6W 22K OHM J
RA73	24366103	CARBON FILM, 1/6W 10K OHM J
RA74	24366332	CARBON FILM, 1/6W 33K OHM J
RA201	24366472	CARBON FILM, 1/6W 4.7K OHM J
RA341	24366223	CARBON FILM, 1/6W 22K OHM J
RB01	24366271	CARBON FILM, 1/6W 270 OHM J
RB03	24366101	CARBON FILM, 1/6W 100 OHM J
RB09	24366470	CARBON FILM, 1/6W 47 OHM J
RB11	24366103	CARBON FILM, 1/6W 10K OHM J
RB21	24366472	CARBON FILM, 1/6W 4.7K OHM J
RB22	24366122	CARBON FILM, 1/6W 1.2K OHM J
RB23	24366222	CARBON FILM, 1/6W 2.2K OHM J
RB24	24366472	CARBON FILM, 1/6W 4.7K OHM J
RB25	24366472	CARBON FILM, 1/6W 4.7K OHM J
RB30	24366103	CARBON FILM, 1/6W 10K OHM J
RB43	24366103	CARBON FILM, 1/6W 10K OHM J
RB44	24366103	CARBON FILM, 1/6W 10K OHM J
RB45	24366181	CARBON FILM, 1/6W 180 OHM J
RB46	24366101	CARBON FILM, 1/6W 100 OHM J
RB47	24366332	CARBON FILM, 1/6W 3.3K OHM J
RB48	24366473	CARBON FILM, 1/6W 47K OHM J
RB49	24366102	CARBON FILM, 1/6W 1K OHM J
RG02	24366101	CARBON FILM, 1/6W 100 OHM J
RG03	24366101	CARBON FILM, 1/6W 100 OHM J
RG05	24366102	CARBON FILM, 1/6W 1K OHM J
RG08	24366394	CARBON FILM, 1/6W 390K OHM J
RG09	24366473	CARBON FILM, 1/6W 47K OHM J
RG14	24366332	CARBON FILM, 1/6W 3.3K OHM J
RG15	24327153	METAL FILM, 1/4W 15K OHM J
RG16	24366162	CARBON FILM, 1/6W 1.6K OHM J
RG17	24366472	CARBON FILM, 1/6W 4.7K OHM J
RG22	24366101	CARBON FILM, 1/6W 100 OHM J
RG23	24366101	CARBON FILM, 1/6W 100 OHM J
RG41	24366103	CARBON FILM, 1/6W 10K OHM J
RG43	24366472	CARBON FILM, 1/6W 4.7K OHM J
RG44	24366222	CARBON FILM, 1/6W 2.2K OHM J

Location No.	Parts No.	Description
RR01	24366102	CARBON FILM, 1/6W 1K OHM J
RR02	24366472	CARBON FILM, 1/6W 4.7K OHM J
RR03	24366102	CARBON FILM, 1/6W 1K OHM J
RR04	24366472	CARBON FILM, 1/6W 4.7K OHM J
RR05	24366102	CARBON FILM, 1/6W 1K OHM J
RR06	24366472	CARBON FILM, 1/6W 4.7K OHM J
RR07	24366681	CARBON FILM, 1/6W 680 OHM J
RR08	24366682	CARBON FILM, 1/6W 6.8K OHM J
RR93	24366472	CARBON FILM, 1/6W 4.7K OHM J
RS02	24366562	CARBON FILM, 1/6W 5.6K OHM J
RS04	24366562	CARBON FILM, 1/6W 5.6K OHM J
RS08	24366562	CARBON FILM, 1/6W 5.6K OHM J
RS10	24366562	CARBON FILM, 1/6W 5.6K OHM J
RS14	24366562	CARBON FILM, 1/6W 5.6K OHM J
RS16	24366562	CARBON FILM, 1/6W 5.6K OHM J
RS25	24366562	CARBON FILM, 1/6W 5.6K OHM J
RS26	24366562	CARBON FILM, 1/6W 5.6K OHM J
RS40	24366272	CARBON FILM, 1/6W 2.7K OHM J
RS42	24366272	CARBON FILM, 1/6W 2.7K OHM J
RS43	24366103	CARBON FILM, 1/6W 10K OHM J
RS44	24366103	CARBON FILM, 1/6W 10K OHM J
RS60	24366101	CARBON FILM, 1/6W 100 OHM J
RS61	24366222	CARBON FILM, 1/6W 2.2K OHM J
RS62	24366101	CARBON FILM, 1/6W 100 OHM J
RS63	24366222	CARBON FILM, 1/6W 2.2K OHM J
RS64	24366102	CARBON FILM, 1/6W 1K OHM J
RS65	24366102	CARBON FILM, 1/6W 1K OHM J
RS66	24366102	CARBON FILM, 1/6W 1K OHM J
RS68	24366223	CARBON FILM, 1/6W 22K OHM J
RS69	24366223	CARBON FILM, 1/6W 22K OHM J
RS70	24366104	CARBON FILM, 1/6W 100K OHM J
RS71	24366104	CARBON FILM, 1/6W 100K OHM J
RS101	24366123	CARBON FILM, 1/6W 12K OHM J
RS102	24366123	CARBON FILM, 1/6W 12K OHM J
RS105	24366222	CARBON FILM, 1/6W 2.2K OHM J
RS107	24366473	CARBON FILM, 1/6W 47K OHM J
RS108	24366473	CARBON FILM, 1/6W 47K OHM J
RS109	24366103	CARBON FILM, 1/6W 10K OHM J
RS113	24366103	CARBON FILM, 1/6W 10K OHM J
RS611	24366101	CARBON FILM, 1/6W 100 OHM J
RS612	24366101	CARBON FILM, 1/6W 100 OHM J
RS613	24366101	CARBON FILM, 1/6W 100 OHM J
RS614	24366101	CARBON FILM, 1/6W 100 OHM J
RV02	24366750	CARBON FILM, 1/6W 75 OHM J
RV04	24366750	CARBON FILM, 1/6W 75 OHM J
RV05	24366750	CARBON FILM, 1/6W 75 OHM J
RV07	24366103	CARBON FILM, 1/6W 10K OHM J
RV09	24366750	CARBON FILM, 1/6W 75 OHM J
RV10	24366750	CARBON FILM, 1/6W 75 OHM J
RV11	24366100	CARBON FILM, 1/6W 10 OHM J
RV12	24366103	CARBON FILM, 1/6W 10K OHM J
RV19	24366101	CARBON FILM, 1/6W 100 OHM J
RV20	24366101	CARBON FILM, 1/6W 100 OHM J
RV35	24366103	CARBON FILM, 1/6W 10K OHM J
RV36	24366222	CARBON FILM, 1/6W 2.2K OHM J
RV60	24552101	OXIDE METAL FILM, 1/2W 100 OHM J
RV61	24366101	CARBON FILM, 1/6W 100 OHM J
RV62	24366750	CARBON FILM, 1/6W 75 OHM J
RV63	24366101	CARBON FILM, 1/6W 100 OHM J
RW01	24366750	CARBON FILM, 1/6W 75 OHM J
RW02	24366750	CARBON FILM, 1/6W 75 OHM J
RW03	24366750	CARBON FILM, 1/6W 75 OHM J
RZ01	24872102	CHIP, METAL FILM, 1/16W 1K OHM J
RZ02	24872102	CHIP, METAL FILM, 1/16W 1K OHM J
RZ03	24872332	CHIP, METAL FILM, 1/16W 3.3K OHM J

Location No.	Parts No.	Description
RZ04	24872122	CHIP, METAL FILM, 1/16W 1.2K OHM J
RZ05	24872471	CHIP, METAL FILM, 1/16W 470 OHM J
RZ06	24872821	CHIP, METAL FILM, 1/16W 820 OHM J
RZ08	24872122	CHIP, METAL FILM, 1/16W 1.2K OHM J
RZ09	24872101	CHIP, METAL FILM, 1/16W 100 OHM J
RZ10	24872471	CHIP, METAL FILM, 1/16W 470 OHM J
RZ12	24872332	CHIP, METAL FILM, 1/16W 3.3K OHM J
RZ13	24872122	CHIP, METAL FILM, 1/16W 1.2K OHM J
RZ14	24872391	CHIP, METAL FILM, 1/16W 390 OHM J
RZ15	24872391	CHIP, METAL FILM, 1/16W 390 OHM J
RZ17	24872471	CHIP, METAL FILM, 1/16W 470 OHM J
RZ18	24872122	CHIP, METAL FILM, 1/16W 1.2K OHM J
RZ19	24872332	CHIP, METAL FILM, 1/16W 3.3K OHM J
RZ20	24872101	CHIP, METAL FILM, 1/16W 100 OHM J
RZ22	24872471	CHIP, METAL FILM, 1/16W 470 OHM J
RZ29	24872331	CHIP, METAL FILM, 1/16W 330 OHM J
RZ30	24872331	CHIP, METAL FILM, 1/16W 330 OHM J
COILS & TRANSFORMERS		
L101	23289845	COIL, PEAKING 68.00MMHJ, COLTRF4680AT
L111	23289844	COIL, PEAKING, TRF4470AT
L121	23238562	COIL, PEAKING, TRF4109AJ
L122	23238562	COIL, PEAKING, TRF4109AJ
L201	23238703	COIL, PEAKING, TRF4820AJ
L301	23103880	COIL, CHOKE, TEM2011Y
L400	23238714	COIL, PEAKING, TRF4100AJ
△ L441	23233092	COIL, TLN2138G
L442	23248121	COIL, CHOKE, TLN3383D
L447	23248318	CHOKE 17X29H 47MMH
△ L461	23248173	COIL, CHOKE, TLN3333AD
L500	23289840	COIL, PEAKING, TRF4100AT
L501	23289844	COIL, PEAKING, TRF4470AT
L502	23289844	COIL, PEAKING, TRF4470AT
L805	23248213	COIL, CHOKE, TLN3481AH
L806	23248213	COIL, CHOKE, TLN3481AH
L815	23103859	COIL, CHOKE, TEM2011
L816	23103859	COIL, CHOKE, TEM2011
L883	23103859	COIL, CHOKE, TEM2011
L885	23248073	COIL, CHOKE, TLN3299D
L886	23103859	COIL, CHOKE, TEM2011
L901	23200478	COIL, DG 0.60CU 37T-2LOOP
L902	23289221	COIL, PEAKING, TRF4221AF
L903	23289221	COIL, PEAKING, TRF4221AF
L904	23289221	COIL, PEAKING, TRF4221AF
L910	23237991	COIL, PEAKING, TRF4479AC
LA01	23289100	COIL, PEAKING, TRF4100AF
LB01	23262302	IF COIL 11.8MHZ 5SV, TRF1247AH
LV01	23289840	COIL, PEAKING, TRF4100AT
LV02	23103852	COIL, FILTER, TEM2028AH
LV03	23103852	COIL, FILTER, TEM2028AH
LV04	23103852	COIL, FILTER, TEM2028AH
LV45	23289840	COIL, PEAKING, TRF4100AT
LV99	23103845	COIL, COMMONMODE, TEM2030AY
LZ01	23238710	COIL, PEAKING, TRF4220AJ
LZ02	23238714	COIL, PEAKING, TRF4100AJ
LZ03	23238714	COIL, PEAKING, TRF4100AJ
LZ04	23238714	COIL, PEAKING, TRF4100AJ
LZ05	23238714	COIL, PEAKING, TRF4100AJ
LZ08	23238707	COIL, PEAKING, TRF4390AJ
LZ11	23238710	COIL, PEAKING, TRF4220AJ
LZ12	23238710	COIL, PEAKING, TRF4220AJ
T401	23224380	TRANSFORMER, HORIZ DRIVE, TLN1098GH
△ T461	23236746	TRANSFORMER, FBT, TFB4192ZD
T801	23211739	COIL, LINE FILTER, TRF3229AL
T840	23217572	TRANSFORMER, POWER EI28 1, TPW1571AT

Location No.	Parts No.	Description
T862	23217558	TRANSFORMER, CONV TRS EER, TPW3498AE
SEMICONDUCTORS		
Q202	23314965	TRANSISTOR, KTC3198 Y
Q203	23314965	TRANSISTOR, KTC3198 Y
Q204	23114460	TRANSISTOR, RN1204
Q301	23319787	IC, LA7833S
Q301B	72471082	SCREW, 3X10MM
Q361	23314445	TRANSISTOR, 2SC4721, Q
Q370	23314962	TRANSISTOR, KTA1266 Y
Q402	23114755	TRANSISTOR, 2SC2482FA-1
Q403	23314444	TRANSISTOR, 2SC4721, P
Q404	23314955	TRANSISTOR, 2SD2553(FA)
Q404B	72471082	SCREW, 3X10MM
Q462	23314962	TRANSISTOR, KTA1266 Y
Q463	23314938	TRANSISTOR, 2SD2493(P)
Q463B	72471082	SCREW, 3X10MM
Q470	23314965	TRANSISTOR, KTC3198 Y
Q471	23114426	TRANSISTOR, 2SA1015-O(TEM)
Q472	23314965	TRANSISTOR, KTC3198 Y
Q480	23114759	TRANSISTOR, 2SA949-Y
Q481	23314965	TRANSISTOR, KTC3198 Y
Q482	23314965	TRANSISTOR, KTC3198 Y
Q483	23114469	TRANSISTOR, RN2201
Q501	23906843	IC, TA1310N
Q503	23314965	TRANSISTOR, KTC3198 Y
Q610	23000249	IC, TA8265K
Q610B	70391356	SCREW, BITTB3X10 SZN
Q611	23114623	TRANSISTOR, 2SC2878-A(TEM)
Q612	23314962	TRANSISTOR, KTA1266 Y
Q613	23114623	TRANSISTOR, 2SC2878-A(TEM)
Q801	23135032	IC, HYBRID VDSS=450V, STR-G5624A
Q801B	72471082	SCREW, 3X10MM
Q805	23114459	TRANSISTOR, RN1205
Q830	23314141	TRANSISTOR, 2SC3852
Q830B	70391356	SCREW, BITTB3X10 SZN
Q835	23319202	IC, MC7809CT
Q835B	70391356	SCREW, BITTB3X10 SZN
Q840	23318299	IC, L78MR05-FA
Q843	23114459	TRANSISTOR, RN1205
Q901	23314780	TRANSISTOR, 2SC4544
Q902	23314965	TRANSISTOR, KTC3198 Y
Q903	23314780	TRANSISTOR, 2SC4544
Q904	23314965	TRANSISTOR, KTC3198 Y
Q905	23314780	TRANSISTOR, 2SC4544
Q906	23314965	TRANSISTOR, KTC3198 Y
Q907	23314962	TRANSISTOR, KTA1266 Y
Q908	23114429	TRANSISTOR, 2SC2120-Y(TE)
Q910	23314965	TRANSISTOR, KTC3198 Y
Q911	23314965	TRANSISTOR, KTC3198 Y
Q912	23314962	TRANSISTOR, KTA1266 Y
Q913	23314962	TRANSISTOR, KTA1266 Y
Q914	23314965	TRANSISTOR, KTC3198 Y
Q4460	23314965	TRANSISTOR, KTC3198 Y
Q4461	23314965	TRANSISTOR, KTC3198 Y
Q4462	23314965	TRANSISTOR, KTC3198 Y
QA01	23009183	IC, TMP88CS38BN-3PH5
QA02	23905665	IC, AT24C08-10PC
QB01	23314965	TRANSISTOR, KTC3198 Y
QB03	23114459	TRANSISTOR, RN1205
QB22	23114437	TRANSISTOR, 2SC752GTM-Y
QB23	23314965	TRANSISTOR, KTC3198 Y
QB30	23314965	TRANSISTOR, KTC3198 Y
QB40	23314965	TRANSISTOR, KTC3198 Y

Location No.	Parts No.	Description
QB41	23314965	TRANSISTOR, KTC3198 Y
QG01	23906499	IC, UPC1851BCU
QS60	23314965	TRANSISTOR, KTC3198 Y
QS61	23314965	TRANSISTOR, KTC3198 Y
QS62	23114466	TRANSISTOR, RN2204
QS63	23114623	TRANSISTOR, 2SC2878-A(TEM
QS64	23114623	TRANSISTOR, 2SC2878-A(TEM
QS101	23906596	IC, BA4558
QS106	23000529	IC, SW 2IN 1OUT 3CIRCUIT 0 CLP MM1231XD
QV01	23000369	IC, MM1495XD
QV02	23904943	IC, MM1111XS
QV05	23114461	TRANSISTOR, RN1203
QV10	23114461	TRANSISTOR, RN1203
QV11	23114437	TRANSISTOR, 2SC752GTM-Y
QV60	23314965	TRANSISTOR, KTC3198 Y
QZ01	23906904	IC, TC90A49P
QZ02	23314163	TRANSISTOR, 2SA1162-Y
QZ03	23314163	TRANSISTOR, 2SA1162-Y
QZ04	23314163	TRANSISTOR, 2SA1162-Y
QZ05	23314475	TRANSISTOR, 2SC2712-Y
QZ06	23314163	TRANSISTOR, 2SA1162-Y
QZ07	23314163	TRANSISTOR, 2SA1162-Y
QZ08	23314475	TRANSISTOR, 2SC2712-Y
D101	23316755	DIODE, ZENER, MTZJ33C
D201	23316817	DIODE, 1SS120-7
D221	23316817	DIODE, 1SS120-7
D222	23316817	DIODE, 1SS120-7
D223	23316817	DIODE, 1SS120-7
D224	23316817	DIODE, 1SS120-7
D252	23118518	DIODE, ZENER, RD9.1ES
D253	23118518	DIODE, ZENER, RD9.1ES
D301	23118095	DIODE, ERB44-06
D302	23118095	DIODE, ERB44-06
D310	23118859	DIODE, 1SS133
D316	23316679	DIODE, ZENER, MTZJ6.8C
D319	23316719	DIODE, ZENER, MTZJ12B
D370	23316672	DIODE, ZENER, MTZJ5.6B
D371	23118859	DIODE, 1SS133
D404	23316254	DIODE, ERC06-15
D406	23118094	DIODE, EU2A
D408	23357353	DIODE, FML-G22S
D408	23118052	DIODE, RU4Z LF-L1
D409	23316690	DIODE, ZENER, MTZJ10B
D411	23118520	DIODE, ZENER, RD8.2ES B2
D430	23118510	DIODE, ZENER, RD12ES
D441	23316687	DIODE, ZENER, MTZJ9.1B
D442	23118094	DIODE, EU2A
D460	23316969	DIODE, ERD29-06
D462	23316653	DIODE, ZENER, MTZJ2.7B
D467	23118095	DIODE, ERB44-06
D471	23118095	DIODE, ERB44-06
△ D472	23115774	DIODE, ZENER, RD6.2E(FA-1)
D473	23118859	DIODE, 1SS133
D477	23118859	DIODE, 1SS133
D480	23316727	DIODE, ZENER, MTZJ16A
D611	23118859	DIODE, 1SS133
D612	23118859	DIODE, 1SS133
D613	23118859	DIODE, 1SS133
D614	23118859	DIODE, 1SS133
D801	23316391	DIODE, D3SB60(4103)
D805	23118859	DIODE, 1SS133
D806	23118094	DIODE, EU2A
D807	23118859	DIODE, 1SS133
D810	23316269	DIODE, AK04
D830	23316673	DIODE, ZENER, MTZJ5.6C

Location No.	Parts No.	Description
D840	23316962	DIODE, S1WBA20
D845	23118859	DIODE, 1SS133
D855	23118859	DIODE, 1SS133
D883	23357344	DIODE, VRM=600V IF(AV)=1.5A, RU3AM
D885	23118094	DIODE, EU2A
D899	24019485	VARISTOR, TNR10V431K
D901	23118859	DIODE, 1SS133
D902	23118859	DIODE, 1SS133
D903	23118859	DIODE, 1SS133
D904	23118859	DIODE, 1SS133
D905	23118859	DIODE, 1SS133
D906	23118859	DIODE, 1SS133
D911	23118095	DIODE, ERB44-06
DA42	23118529	DIODE, ZENER, RD5.6ES B2
DB03	23358522	DIODE, LED, SIR-56SB3F
DB30	23118859	DIODE, 1SS133
DB45	23316817	DIODE, 1SS120-7
DE50	23358564	DIODE, LED, SLR-56VC3FPQ
DS106	23316672	DIODE, ZENER, MTZJ5.6B
DV46	23316716	DIODE, ZENER, MTZJ11B
DV47	23316686	DIODE, ZENER, MTZJ9.1A
MISCELLANEOUS		
B230	23037312	SCREW, BTBW3X12SZN
B231	23035412	SCREW, BTB4X12SZN
B232	23035312	SCREW, BTB3X12SZN
BB01A	23713201	CONNECTOR, 16P
BB01B	23713202	CONNECTOR, 16P
BB02A	23713201	CONNECTOR, 16P
BB02B	23713202	CONNECTOR, 16P
BB03	23368627	CONNECTOR, BRIDGE B-B 8P 2.5JST 08TM-2.5FJ-E
BB03A	23903022	CONNECTOR, BASE B-B 8P 2.5 JST
BB03B	23903022	CONNECTOR, BASE B-B 8P 2.5 JST
BB04A	23902749	CONNECTOR, SOCKET, B-B 6P
BB04B	23368517	CONNECTOR, PLUG, B-B 6P
F470	23144731	FUSE, CARTRIDGE, 5.2X20, 1.6A 125V
F470	23144906	FUSE, CARTRIDGE, F1.25U1
F470A	23165433	FUSE HOLDER, 5.2 SOC
F801	23144518	FUSE, CARTRIDGE, 125V 10A
F801A	23165433	FUSE HOLDER, 5.2 SOC
F802	23144733	FUSE, CARTRIDGE 5.2X20, 125V 3.15A
F802A	23165433	FUSE HOLDER, 5.2 SOC
F803	23144859	FUSE, CARTRIDGE 5.2X20, 125V 2.0A
F803A	23165433	FUSE HOLDER, 5.2 SOC
G060	24366470	CARBON FILM, 1/6W 47 OHM J
G217	24366393	CARBON FILM, 1/6W 39K OHM J
G301	24366102	CARBON FILM, 1/6W 1K OHM J
G317	23118859	DIODE, 1SS133
G403	24946223	CARBON COMPOSITION GF 1/2W 22K K
G405	24214472	CERAMIC DISK CK45 B 500V 4700PF K
G463	23103859	COIL, CHOKE, TEM2011
G845	23103859	COIL, CHOKE, TEM2011
G890	23280016	COIL, PEAKING, TRF4100AZ
G891	23280016	COIL, PEAKING, TRF4100AZ
G908	23289100	COIL, PEAKING, TRF4100AF
G933	24366750	CARBON FILM, 1/6W 75 OHM J
H003	23365089	CONNECTOR ASSY
H003A	23740989	NUT, F-CONNECTOR 2H BS
KB01	23906805	IC, REMOTE PHOTO RECIEVER, PIC-TB17
M461A	23192945	ANODECAP ASSEMBLY, TCCP5162
M461B	23504203	CABLE, FOCUS
M461C	23504204	CABLE, SCREEN
N726	23969041	TAPE WHITE 3M #1, W=1 INCH TNP COMMON
N726	23969041	TAPE WHITE 3M #1, W=1 INCH TNP COMMON

Location No.	Parts No.	Description
N727	23969041	TAPE WHITE 3M #1, W=1 INCH TNP COMMON
N727	23969041	TAPE WHITE 3M #1, W=1 INCH TNP COMMON
P801	23372112	POWER CORD, U/C 125V10A HSV 1 CMC-02P
P910	23164725	CONNECTOR, PLUG 2P
PV02	23365949	JACK, 5P, 1E:OFF+2R:OFF+2L:OFF, JALC
PV03	23365821	PIN JACK, (1E:OFF+1R:OFF+1L:OFF JACK 3P
PV04	23365763	JACK, PIN, 3P
PV011	23365863	JACK, PIN JACK 2S6P, JXT1140-01008
PZ01	23368130	CONNECTOR, 10P
PZ01A	23902213	CONNECTOR, 10P
SA01	23145430	SWITCH, PUSH, SKHHLMA010
SA02	23145430	SWITCH, PUSH, SKHHLMA010
SA03	23145430	SWITCH, PUSH, SKHHLMA010
SA04	23145430	SWITCH, PUSH, SKHHLMA010
SA05	23145430	SWITCH, PUSH, SKHHLMA010
SA06	23145430	SWITCH, PUSH, SKHHLMA010
SA07	23145430	SWITCH, PUSH, SKHHLMA010
SR81	23146564	RELAY, DC12V, TV5, DG-3
SR83	23146564	RELAY, DC12V, TV5, DG-3
V901A	23902068	SOCKET CRT, 10P HOSIDEN HPS0360
W661	23351088	SPEAKER, SPK1360, 60X120 8-OHM 5W
W662	23351088	SPEAKER, SPK1360, 60X120 8-OHM 5W
X401	23153721	CERAMIC RESONATOR, 503KHZ
X501	23153961	CRYSTAL, 3.58MHZ
XA01	23153504	CERAMIC RESONATOR, 8.00MHZ 25OHM
ZY01	23148771	MULTI PICTURE MODULE, PNT 6MW
PC BOARD ASSEMBLIES		
* U801	23787513	POW/DEF BOARD, PD0701A
* U901	23787511	CRT/D BOARD, PD0655A
* U902	23787516	SIGNAL BOARD, PD0654C
* U905	23786166	3LINE B BOARD, PB9398A
PICTURE TUBE		
△ V901	23312973	PICTURE TUBE, TDD32FSAK, A80AKB50X05
TUNER		
H001	23321438	TIF 181CH PH 5V MPX BUNKI, EL968L
HY01	23321437	TIF 181CH PH 5V, EL975L
ACCESSORIES		
K912	23306263	REMOTE CONTROL TRANSMITTER, CT-9946
Y101	23565629	OWNER'S MANUAL, ENGLISH, 32A62
Y101F	23565630	OWNER'S MANUAL, FRENCH, 32A62
CABINET PARTS		
A201	23530264	FRONT COVER ASSY 32A62
A213	23428083	DOOR, DOOR 32A62
A224	23445475	BUTTON, CONTROL BUTTON 36AX61 36AX60
A701	23064843	CARTON, CARTON 32A62
A703	23946373	TOP PACKING 32A62
A708	23946374	BOTTOM PACKING 32A62

Location No.	Parts No.	Description
--------------	-----------	-------------

**THIS PAGE IS
INTENTIONALLY LEFT
BLANK.**

SIGNAL BOARD PD0654C
BOTTOM (FOIL) SIDE

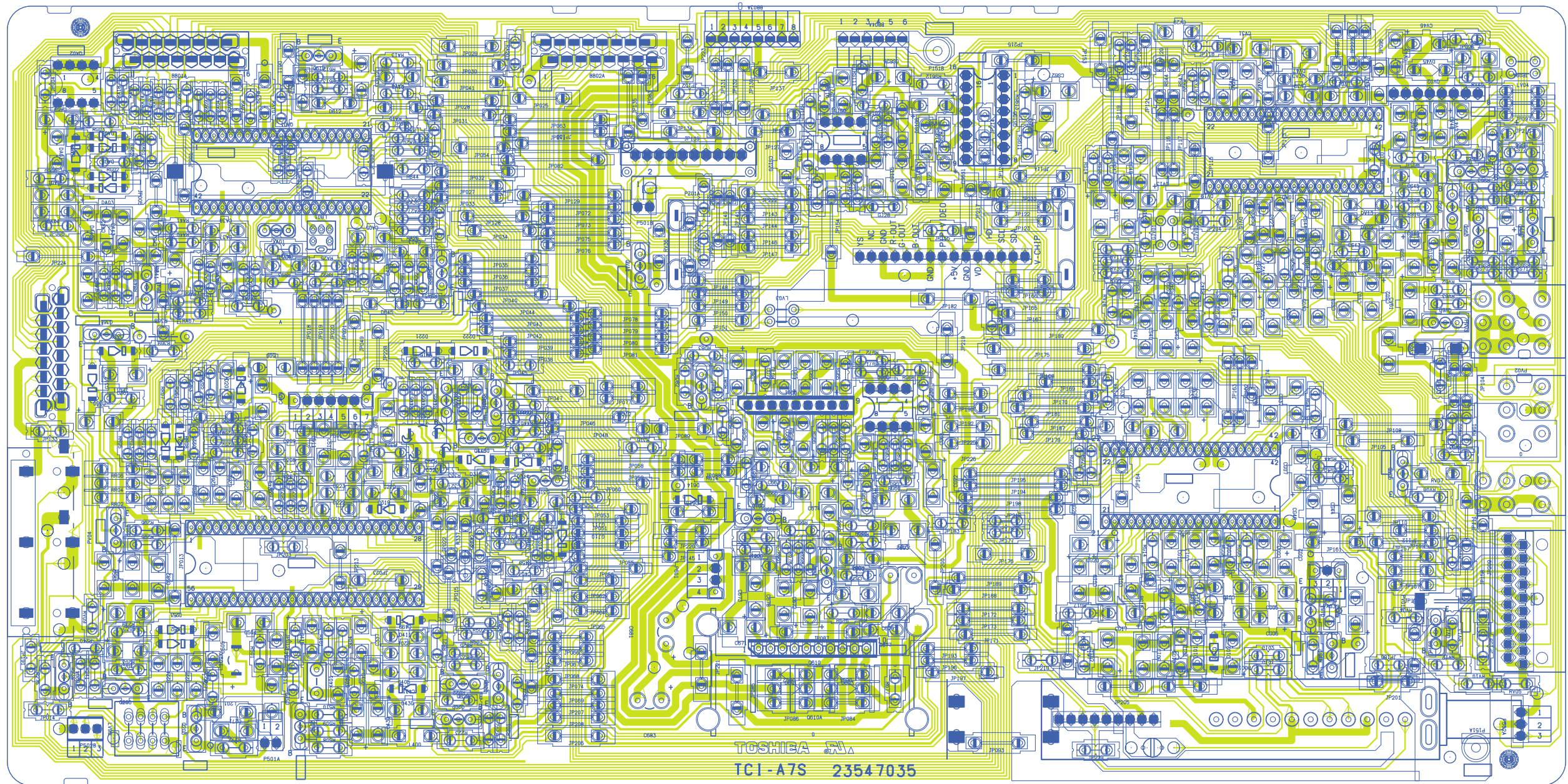

POWER/DEF BOARD PD0701
BOTTOM (FOIL) SIDE

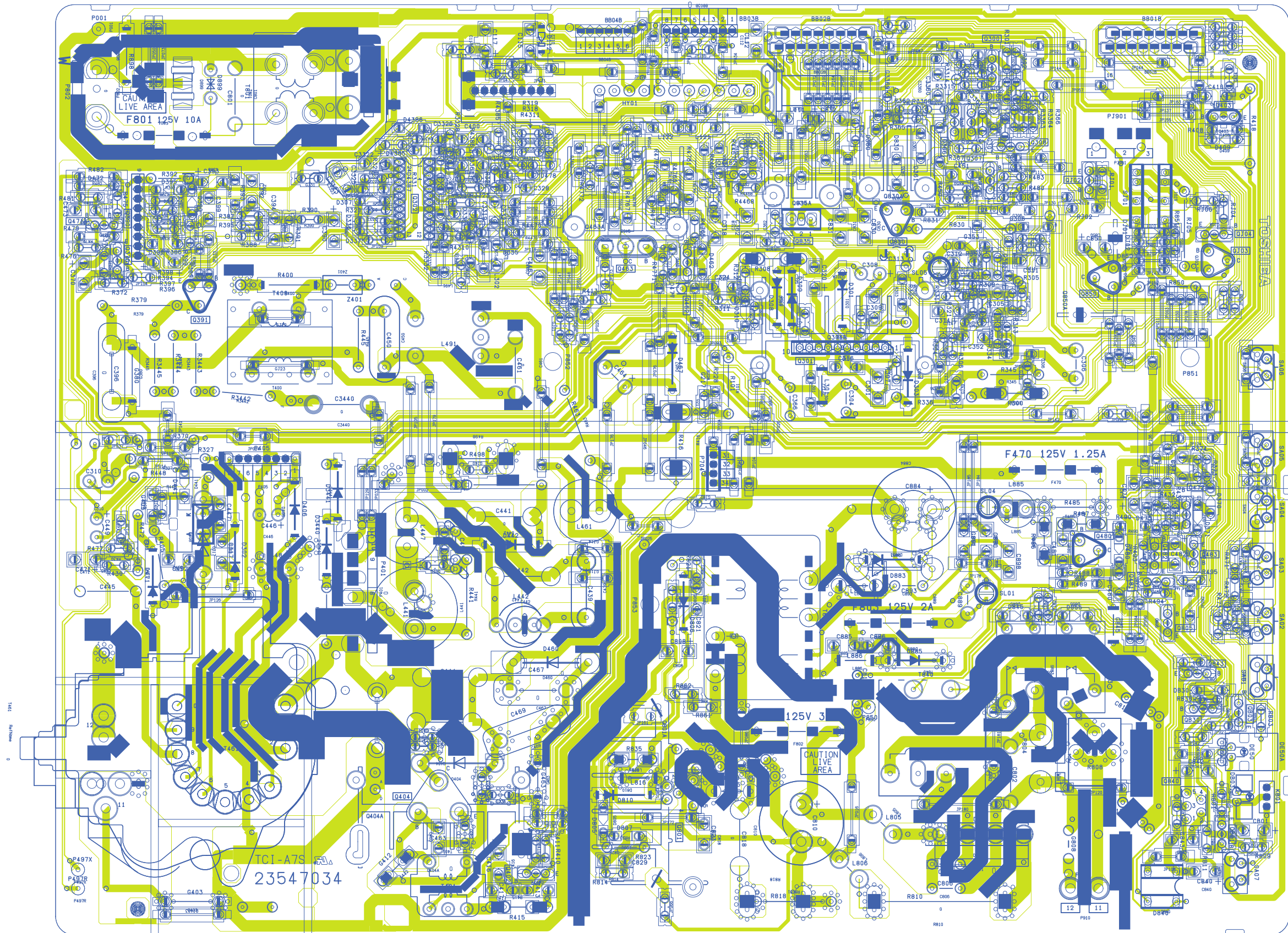

CRT DRIVE BOARD PD0655
BOTTOM (FOIL) SIDE

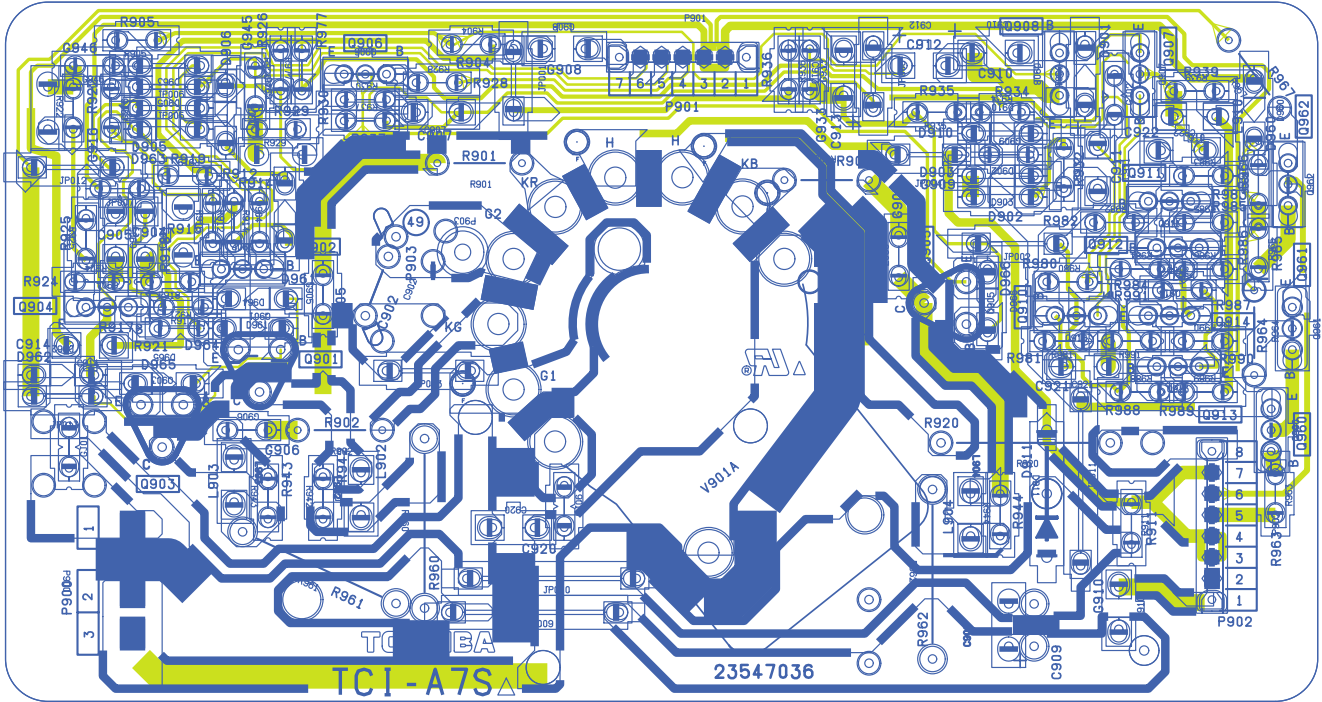

3L BOARD PB9398
BOTTOM (FOIL) SIDE

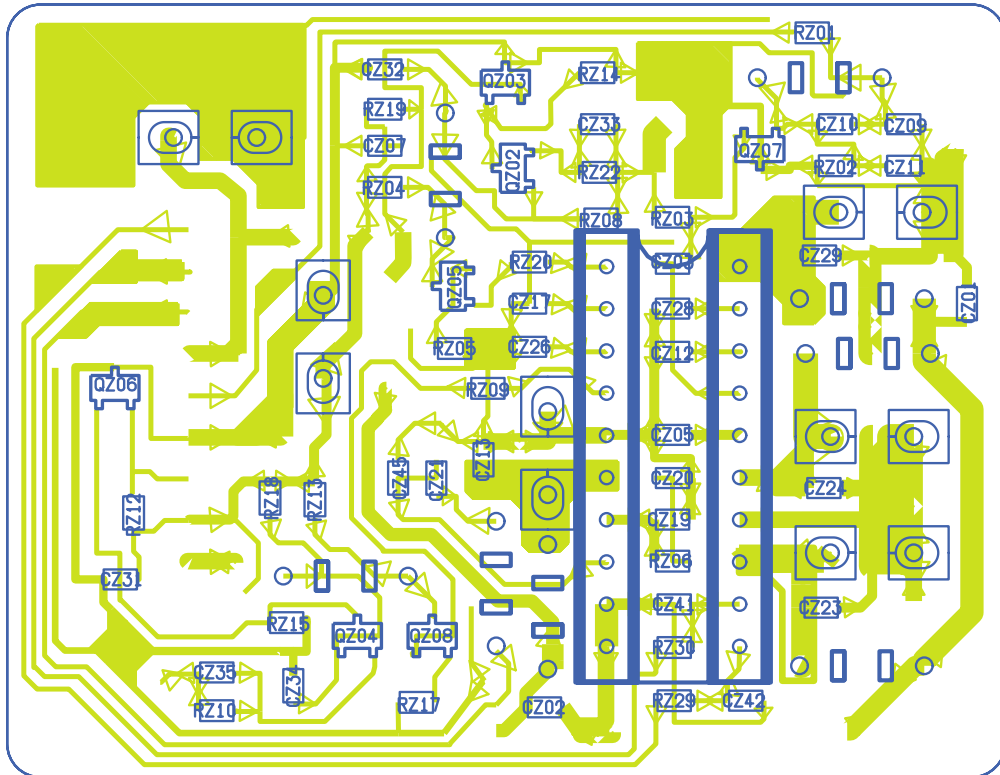

TERMINAL VIEW OF TRANSISTORS

SPECIFIC INFORMATIONS

① 2SD2253
(old)
2SC5243

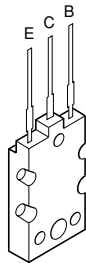

② 2SC3852
2SD1763A
2SC1569
2SC4544
2SA1788
2SA1306
2SA1186A

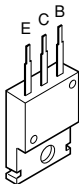

③ 2SC752GTM
2SC2482
2SC2655
2SC4721P



④ 2SC752
2SA562TM
2SA1015
2SC1815
2SC2878
2SC1740S
2SC2120
2SA9335



⑤ 2SA1788

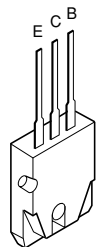

⑥ RN2203
RN2201
RN2004
RN1203
RN1204
RN2204
RN1205
RN1202
RN1201

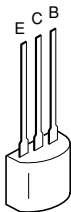

⑦ 2SD1554
2SD2253
2SD1556
2SD2553
2SC5143

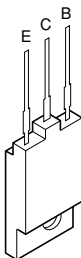

⑧ ON4409

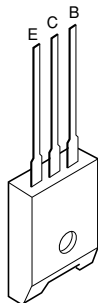

CIRCUIT BLOCK DIAGRAM

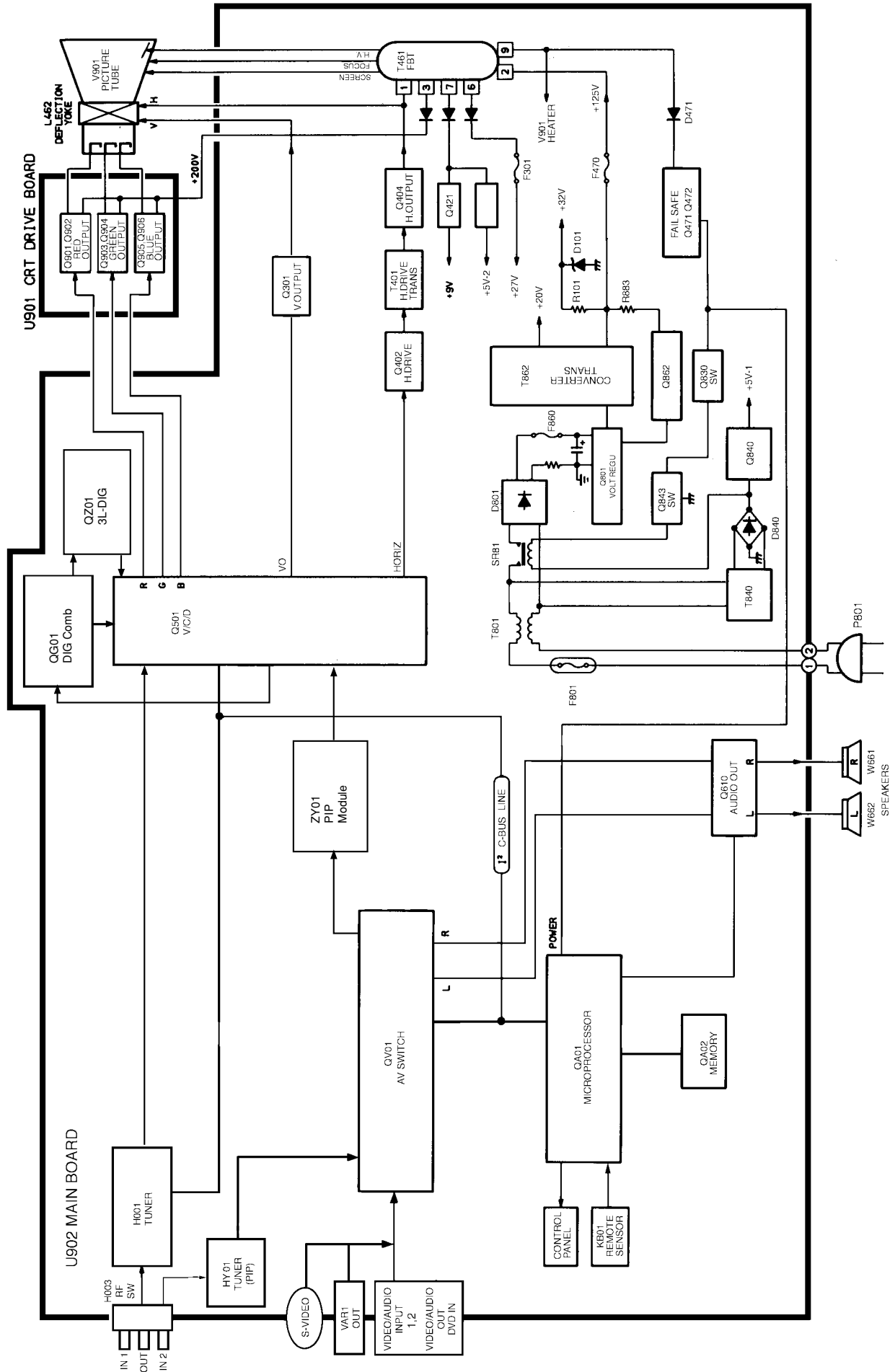

SPECIFICATIONS	
TELEVISION SYSTEM	NTSC standard
CHANNEL COVERAGE	VHF: 2 through 13 UHF: 14 through 69 Cable TV: mid band (A-8 through A-1, A through I) super band (J through W) hyper band (AA through ZZ, AAA, BBB) ultra band (65 through 94, 100 through 125)
POWER SOURCE	120V AC, 60Hz, 102W
AUDIO POWER	5W + 5W
SPEAKER TYPE	2-3/8 x 4-3/4 inches (60 x 120 mm)
VIDEO/AUDIO TERMINALS	S-VIDEO INPUT Y: 1V (p-p), 75 ohm, negative sync. C: 0.286V (p-p) (burst signal), 75 ohm VIDEO/AUDIO INPUT VIDEO: 1V(p-p), 75 ohm, negative sync. AUDIO: 150mV(rms) (30% modulation equivalent, 47k ohm) ColorStream™ (Color Difference) VIDEO/AUDIO INPUT Y: 1V (p-p), 75 ohm Cr: 0.7V (p-p), 75 ohm Cb: 0.7V (p-p), 75 ohm AUDIO: 2V (p-p), 1 kohm
DIMENSIONS	Width 864 mm Height 696 mm Depth 529 mm
MASS	56.0 kg

TOSHIBA CORPORATION
1-1, SHIBAURA 1-CHOME, MINATO-KU, TOKYO 105-8001, JAPAN