



FREE STANDING VENT HOOD AND CHICKEN DISPLAY Assembly Instructions



302 Spencer Lane • P.O. Box 5369 • San Antonio, Texas 78201

(800) 525-8130 - Fax: (210) 731-5099 - www.ultrafryer.com

30A150

PREFACE

This Manual was written and published by the Engineering Department, Ultrafryer Systems for use by equipment installers who will install the Free Standing Exhaust Vent Hood and Three (3) Window Chicken Display in a commercial cooking environment.

**ENGINEERING DEPARTMENT
ULTRAFRYER SYSTEMS
302 SPENCER LANE
SAN ANTONIO, TX 78201**

TABLE OF CONTENTS

GENERAL INFORMATION	PAGE
Warranty	2
Safety	3
Description / Specifications	3-4
Dimensions / Electrical Requirements	3
 UNPACKING, INSTALLATION, CLEANING AND ACCESSORIES	
Unpacking	6
Installation	6-7
Cleaning	7
Accessories	7
 SERVICE AND PARTS	
Technical Assistance	9
Ordering Information	9
Parts Identification	9-13
 WIRING LADDER DIAGRAM	17

LIST OF ILLUSTRATIONS

ASSEMBLY	PAGE
Figure 1 - Hi-Reach Supported Three (3) Window Chicken Display	8
Figure 2 - Bracket Kit Identification	8
Figure 3 - Installation Location Bracket #1	8
Figure 4 - Installation Location Bracket #3	8
Figure 5- Installation Location Bracket #4	9
Figure 6- Installation Location Bracket #5	9
NOTE: No Installation Location Photograph for Bracket #2	

GENERAL INFORMATION

A. WARRANTY

ULTRAFRYER SYSTEMS ASSOCIATED EQUIPMENT WARRANTY

Ultrafryer Systems warrants to the original purchaser of the BATTER/SIFTER CART, VENT HOODS, PRODUCTION COUNTERS, and EXPEDITE STATIONS sold within the United States, its territories and Canada, that it will be free of defects in material and workmanship for the period listed below:

PARTS WARRANTY - Parts are covered for a period of one (1) year from the initial start up date. Ultrafryer Systems reserves the right to charge for certain parts that exceed the price of \$100.00 until the defective part is returned to Ultrafryer. After inspection, and a determination is made that the defect is not the result of neglect or abuse a credit will be issued to the equipment owner's account. All parts are to be shipped back to Ultrafryer Systems, ATTN: WARRANTY DEPARTMENT, and **prepaid by the customer.**

QUARTZ LAMPS - The QUARTZ LAMPS that are supplied with WARMERS are NOT under any warranty with Ultrafryer Systems.

PROCESSING WARRANTY CLAIMS - The equipment owner must promptly notify Ultrafryer Systems Warranty Department of any alleged defects as soon as discovered by calling 800-525-8130. After such notice, the Warranty Department will perform its obligation under this warranty within a commercially reasonable period of time. If alleged defects develop after normal business hours, on weekends, or holidays the owner must call Ultrafryer Systems first at the above number. This number is monitored 24 hours a day and 7 days a week. Ultrafryer Systems will notify an AUTHORIZED service agent to make repairs during normal hours and, if necessary, after normal working hours. Any repairs done without AUTHORIZATION from Ultrafryer Systems on equipment under the warranty is subject to non-payment by Ultrafryer Systems.

NON WARRANTY COVERAGE - This warranty does not include coverage for any consequential cost of damages including, but not limited to, any loss in store sales, spoiled food products, transportation, duty or custom cost. This does not cover original installation and adjustments such as leveling, calibrations, electrical connections nor damage or defects resulting from such. This warranty does not cover travel over 100 miles or 2 hours drive time from the location of the BATTER/SIFTER CART, VENT HOOD, PRODUCTION COUNTER, and EXPEDITE STATION, or overtime, or unauthorized repairs or installation, damage in shipment. Normal maintenance and cleaning are the responsibility of the operator. This warranty does not cover any other equipment that may be supplied to the PRODUCTION COUNTER, or EXPIDITE STATION. **If a dealer supplies any accessories to the Ultrafryer Systems PRODUCTION COUNTER or EXPEDITE STATION, the owner must notify the dealer** of any defects for repair or supply of any parts. **Ultrafryer Systems reserves the right to void any component part warranty on the BATTER/SIFTER CART, VENT HOOD, PRODUCTION COUNTER, and EXPEDITE STATION that is stored for more than 6 (six) months after shipment from Ultrafryer Systems and not put into service.**

LABOR COVERAGE - The cost for labor to replace parts or service the BATTER/SIFTER CART, VENT HOOD, PRODUCTION COUNTER, and EXPEDITE STATION is covered for a period of one (1) year from the initial start up date. The warranty department must be promptly notified of any defects within the first year of operation. An AUTHORIZED service agent of Ultrafryer Systems will cover labor for repairs and service.

DISCLAIMER OF WARRANTIES

Other than as stated herein Ultrafryer Systems makes no warranty of any kind, express or implied, including but not limited to any warranty of merchantability of fitness for a particular purpose, including trade usage. Ultrafryer Systems sole obligation, and purchaser's sole remedy, under this warranty is repair or replacement, at the discretion of Ultrafryer Systems, of any part or component that proves to be defective in materials or workmanship. In no event shall Ultrafryer Systems be liable for consequential, incidental, or special loss or damages arising from the use of, or inability to use, the BATTER/SIFTER CART, VENT HOOD, PRODUCTION COUNTER, and EXPEDITE STATION. There are no other documents or oral statements for which Ultrafryer Systems will be responsible.

B. SAFETY

SAFETY: The major safety concern associated with the Free Standing Exhaust Vent Hood and Three (3) Window Chicken Display is burns from Quartz Warmer Lamps above and below the three (3) Window Chicken Display, and above the Chicken Dump area above the Fryer's exhaust hood. The Free Standing Vent Hood operates on 120 VAC, single (1 Ø) Phase, electrical power. **NO** repair to Warmer Lamp Assemblies should ever be attempted without first disconnecting **ALL** electrical power as, **FAILURE** to do so could result in serious electrical shock or death.

C. DESCRIPTION

DESCRIPTION - The Free Standing Exhaust Vent Hood and Three (3) Window Chicken Display was designed by Ultrafryer Systems to operate as a Fryer's Exhaust Hood and Three (3) Window Chicken Display which can be accessed from the front, rear and side to expedite filling the Customer's orders. It is constructed from 16, 18 and 20 gauge, type 304 stainless steel with a #3 finish. The Exhaust Hood is equipped with two (2) stainless steel grills for the Chicken Trough, two (2) grease catch pans beneath the trough, five (5) Quartz Warmer Lamps above the Chicken Trough and four (4) 12" (305mm) x 20" (508mm) exhaust filters. The Three (3) Window Chicken Display is equipped with four (4) grills (1 Large, 2 Narrow and 1 Small) and four (8) Quartz Warmer Lamps, four (4) above and four (4) below the Chicken Display area.

D. DIMENSIONS / ELECTRICAL REQUIREMENTS



DIMENSIONS

THREE (3) WINDOW CHICKEN DISPLAY

- * 43" (1992mm) Deep
- 39" (991mm) Wide
- 73" (1854mm) High
- * - At its deepest point

EXHAUST HOOD

- 14" (483mm) Deep
- 83" (2108mm) Wide
- 73" (1854mm) High

ELECTRICAL REQUIREMENTS - 120 Volts 60 Hz single (1 Ø) Phase 41 Amps

Three (3) Window Chicken Display



Exhaust Vent Hood



Quartz Warmer Lamp
Above Chicken display

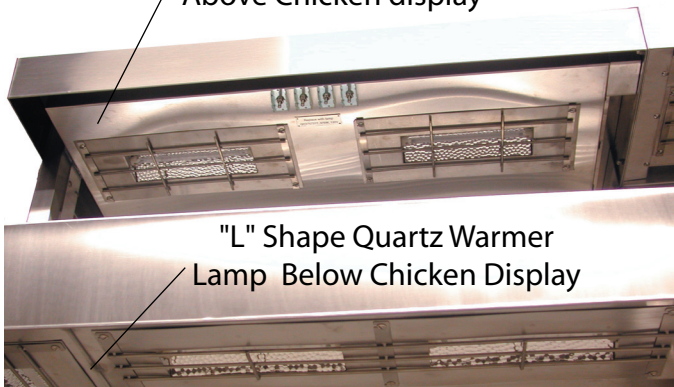

"L" Shape Quartz Warmer
Lamp Below Chicken Display

Quartz Warmer Lamp
Above Chicken Trough
On Exhaust Vent Hood



**UNPACKING, INSTALLATION, CLEANING AND
ACCESSORIES**

A. UNPACKING - The Free Standing Vent Hood and Three (3) Window Chicken Display will be received in two (2) crates, one containing the Fryer exhaust Hood and one containing the Three (3) Window Chicken Display. **CAREFULLY** remove the packing material from each crate and **THOROUGHLY** check each item for visible damage. If Damage is found **DO NOT** refuse shipment, but contact the Carrier and file the appropriate claims.

1. Fryer Exhaust Hood:
 - a. Unwrap, remove and temporarily set aside all parts or accessories.
 - b. **CAREFULLY** place the Fryer's Exhaust Hood at its operating location; then place the four (4) exhaust filters, two (2) grease catch pans and two (2) stainless steel trough grills nearby for later installation.
2. Three (3) Window Chicken Display
 - a. Unwrap, remove and temporarily set aside all parts and accessories.
 - b. **CAREFULLY** place the Three (3) Window Chicken Display adjacent to the Exhaust Hood supported by a **HI-LIFT** as shown in Figure 1 page 8.

NOTE: If a HI-LIFT is not available, it is strongly recommended to rent one as it is extremely difficult to attach this item to the Exhaust Hood.

- c. Place the four (4) stainless steel grills, upper L Bracket, rear mounting bracket, cover plate and mounting hardware package near the installation location. See Illustration on page 8 Figure 2 for Bracket kit Identification.

B. INSTALLATION - Assemble the Three (3) Window Chicken Display to the Exhaust Hood in the following sequence.
See Illustrations on pages 8 and 9.

CAUTION: DO NOT WELD THE EXHAUST DUCT TO THE EXHAUST HOOD AND DO NOT INSTALL WIRE CHASE TO THE EXHAUST HOOD UNTIL THE FOLLOWING INSTALLATION IS COMPLETE.

1. Exhaust Hood
 - a. **ENSURE** the Exhaust Hood is in the **EXACT** operating location.
 - b. **CAREFULLY** level the Hood in **ALL** directions by adjusting the four (4) 3 1/2" (89mm) **FLANGED FEET**.
2. Three (3) Window Chicken Display

NOTE: It is extremely difficult to complete the following steps **WITHOUT** use of a **HI-LIFT!**

- a. **CAREFULLY** position the Display on the **HI-LIFT** adjacent to the Hood with the **FRONT** edge of the **TOP** Chicken Warmer aligned with the **FRONT** edge of the Hood Warmer.
- b. When the **FRONT** edges are aligned; **RAISE** the right side of the Display about 3" (76mm), guide the Display / **HI-LIFT** towards the Hood until it is flush against the Hood, then **CAREFULLY** lower the Display so it's **LOWER** right edge is **SEATED** in the **LIP** of the Hood.
- c. **CAREFULLY** lower the Display, if necessary, until the **TOP**, **REAR** and **FRONT** of the Display are equal distance from the Hood.
- d. **TEMPORARILY** install the following hardware, brackets, gussets etc. to the Three (3) Window Chicken Display and Exhaust Hood **FINGER TIGHT!**
 - 1) Insert two (2) 10-24 x 1/2" (13mm) truss head screws in the holes near the leading edges of the Hood and Display, then place a 10-24 washer and hex nut on the Display side of these screws.
 - 2) Install the triangular gusset beneath the Hood Trough adjacent to the display on the five (5) weld studs, then place a 10-24 acorn nut on each stud.
 - 3) Insert two (2) 1/4-20 x 3/4" (19mm) hex head bolts in the holes in the **TOP** of the Hood Warmer and the **TOP** of the Display Warmer; and place a lock washer and a 1/4-20 acorn nut on the display side.
 - 4) Place the 1" (25mm) x 1 1/2" (38mm) x 11" (279mm) long "L" shaped bracket (item 3, figure 2 and 4 page 8) over the three (3) 10-24 weld studs on the **TOP FLANGE** of the Display and the three (3) 10-24 weld studs on the **TOP FLANGE** of the Hood. When properly positioned; place a 10-24 lock washer and hex nut on each stud of the Display flange and a 10-24 acorn nut on each stud of the Hood flange.
 - 5) Position the 12" (305mm) x 20 1/2" (521mm) face plate (item 5, figure 2 page 8 and figure 6 page 9) with the 1/2" (13mm) hem inside the Display with the hem against the **FRONT** of the Hood, and the six (6) holes in the plate over the six (6) 10-24 nuts on the side of the Hood. When properly positioned, install a 10-24 acorn nut on each nut sert.

- 6) Place the 3” (76mm) x 15 1/2” (394mm) REAR bracket (item 1, figure 2 page 8) with six (6) holes over the three (3) 10-24 nutserts on the rear of the Hood and the three (3) 10-24 nutserts on the rear of the Display; then place a 10-24 acorn nut on each weld stud.
- 7) Remove the “HorseShoe” COVER PLATE (item 4, figure 2 page 8) inside the Chicken Warmer adjacent to the Hood by removing the two (2) 10-24 acorn nuts, remove the COVER PLATE (item 2, figure 2 page 8) attached to the Warmer Lamp Assembly inside the Hood Warmer adjacent to the Display by removing the three (3) 10-24 truss head screws. Route the four (4) Warmer Lamp wires, in the Heat Shrink Tubing, from the Chicken Warmer through the 7/8” (22mm) hole into the HOOD Warmer. Match the number on these eight (8) wires, twist each pair of numbered wires together and secure these connections using the wire nuts provided. Then, replace and secure the COVER PLATE in the Chicken Warmer using the two (2) 10-24 acorn nuts previously removed. Replace and secure the COVER PLATE (item 2, figure 2 page 8) in the Hood Warmer using the three (3) 10-24 truss head screws previously removed.
- 8) SECURELY tighten the hardware installed FINGER TIGHT in the above steps.
- 9) CAREFULLY remove the HI-LIFT from beneath the Three (3) Window Chicken Display; then LEVEL the Display in ALL directions by adjusting the two (2) 3 1/2” (89mm) FLANGED FEET. Check the Exhaust Hood to ensure it is still LEVEL and, if applicable, re-adjust the Hood until it is LEVEL.
- 10) THOROUGHLY Inspect the Three (3) Window Chicken Display and Exhaust Hood areas which will come in contact with FOOD for crevices that have not been sealed with silicone. Any crevice found MUST be sealed with an NSF approved sealant such as Dow Corning RTV732 Multi-Purpose Sealant. Areas of particular concern are as follows:
 - a) Crevice between the UPPER Display Warmer and Hood Warmer.
 - b) Crevice between the LOWER Display Warmer and Hood Trough.
 - c) Around the perimeter of the REAR cover plate.
 - d) Around the BOTTOM, REAR and TOP perimeter of the face plate.

NOTE: Do not place any silicone along the FRONT HEM of the face plate.

 - e) In the SCREW SLOT of ALL truss head screws in a FOOD ZONE area.
- 11) Have a LICENSED Electrician route the four (4) wires from the Display and Hood Warmer Lamps in the “J” box through a wire chase and connect the wires to the Stores main electric panel.

NOTE: All wiring and electrical connections accomplished by the Electrician MUST conform with the latest edition of the National Electric Code ANSI.NFPA 70, Canadian CSA C22.1, Canadian Electrical Code Part I and local electrical codes.

- 12) AFTER paragraphs B2a through B2d10) have been COMPLETED, the Exhaust Duct may be installed and WELDED to the Exhaust Hood.

C. CLEANING

1. THOROUGHLY wash the interior and exterior surfaces of the three (3) Window Chicken Display and Exhaust Hood with HOT Sanitizer Solution to remove oil film, installation or manufacturing residue, etc.; then rinse and wipe these areas dry with a lint free cloth:
2. THOROUGHLY wash the following accessories with HOT Sanitizer Solution, rinse and wipe dry with a lint free cloth:
 - a) Two (2) 12” (305mm) x 42” (1067mm) Exhaust Hood Trough S/S grills.
 - b) Four (4) 12” (305mm) x 20” (508mm) Exhaust Hood Grease Filters.
 - c) Two (2) Grease Catch Pans for the Exhaust Hood Trough.
 - d) Four (4) S/S grills for the Three (3) Window Chicken Display; one (1) 24” (610mm) x 38” (965mm), one (1) 16 3/4” (171mm) x 16” (406mm), and two (2) 6 3/4” (171mm) x 38” (965mm).

D. ACCESSORIES - After the accessories, listed above, have been cleaned and dried, install them in the Free Standing Vent Hood as follows:

- 1) Place the two (2) long grills on the trough of the Exhaust Hood.
- 2) Place the Grease Catch Pans beneath the Exhaust Duct on the Catch Pan Holder on each side of the Vent Hood.
- 3) Install the four (4) Grease Filters on the Filter Trough along the interior of the Hood.
- 4) Place the 24” (610mm) x 38” (965mm) grill in the Chicken Display area, place the two (2) 38” (965mm) long grills in the front and rear pans. Place the remaining grill in the side pan.

Three (3) Window Chicken Display
Supported By Hi-Reach



Figure 1

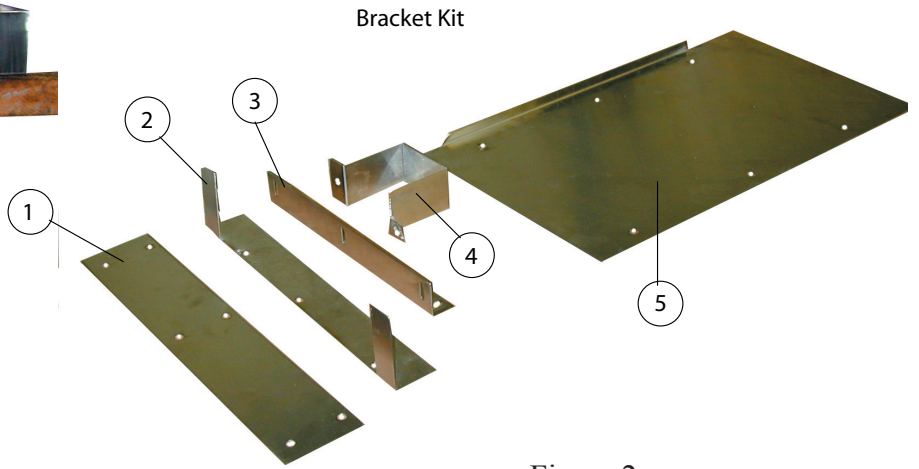

Figure 2

Install Bracket #1 Here



Rear Of Three (3) Window Chicken Display

Figure 3

Install Bracket #3 This Location



Figure 4

Install Bracket #4 This Location



Figure 5

Install Bracket #5 Here

Note Location of Angle

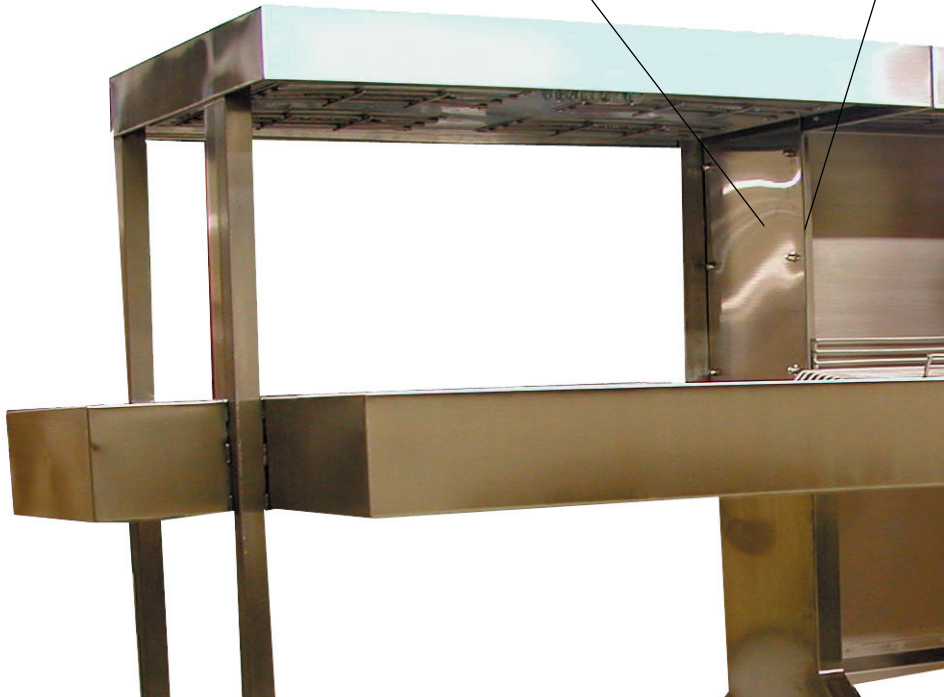

Figure 6

SERVICE AND PARTS

1. **TECHNICAL ASSISTANCE** - Contact an authorized service agent or the Customer Service Department, Ultrafryer Systems at 1-800-525-8130 for technical assistance.

2. **ORDERING INFORMATION:**

A. **REPLACEMENT PARTS** - Provide the following information when ordering replacement parts by phone, fax or mail:

Your company name and phone number
Your company purchase order number
Bill-to address
Ship-to address
Quantity desired
Part number and description of the desired-item
Your name or signature of authorized-buyer
Phone in order to: 1-800-545-9189 Ext 5029
FAX order to: 1-210-731-5099
Mail order to: Ultrafryer Systems
Order Entry Office
P.O. Box 5369
San Antonio, TX 78201
E-Mail your order to: Ultrafryerservice@ultrafryer.com

B. **TERMS** - Net 30 days for customers on open accounts. Past due balances will be charged 1 % per month (12% per annum) until full balance is paid.

C. **DAMAGES** - Ultrafryer Systems is not responsible for damage occurring in transit. All deliveries must be inspected for damage to shipping containers prior to departure of the delivering carrier. Any damage must be notated on the receiving document to facilitate filing of freight claims. Carriers must be notified immediately and freight inspections must be requested from the carrier. Ultrafryer Systems can and will gladly assist you in preparing and processing of the necessary claims only if proper notification has been accomplished on the carrier delivery document. Damaged equipment and or containers must be available for the claims inspector to inspect.

D. **RETURNS** - Ultrafryer Systems cannot guarantee credit for items returned without proper authorization. All returns must have prior Ultrafryer Systems Customer Service or Warranty department approval. An assigned number will be issued by the approval authority. Please print the assigned number on all returned packages and corresponding paperwork. Returned goods are subject to a 15% restocking charge. Ultrafryer Systems is not responsible for freight charges on returned goods unless authorized by Customer Service and or Warranty personnel. Ultrafryer Systems does not receive freight collect or C.O.D. shipments.

3. **PARTS IDENTIFICATION** - Locate the part on the following sketches and note the index number i.e, 4, 7, etc; then obtain the part number and description for that index number on the right side of the page facing the sketch. Use that part number when ordering a replacement part.

**FREE STANDING VENT HOOD & THREE
(3) WINDOW CHICKEN DISPLAY**

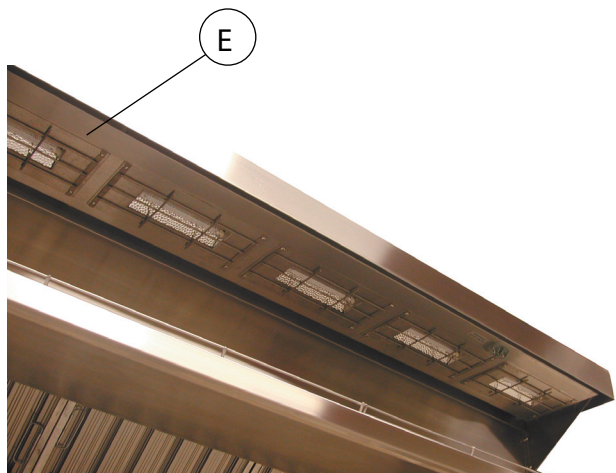
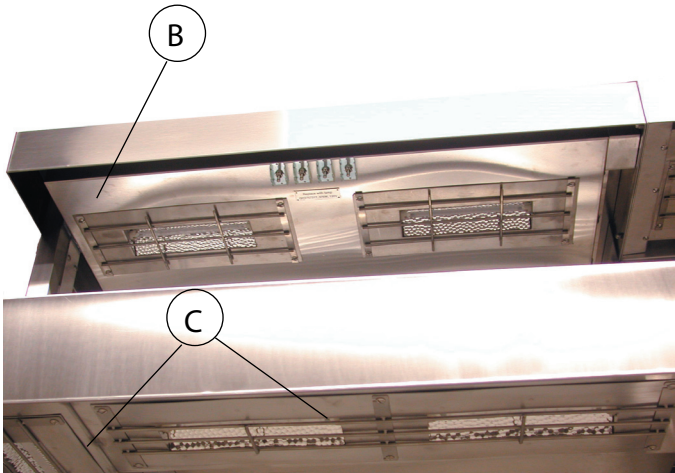
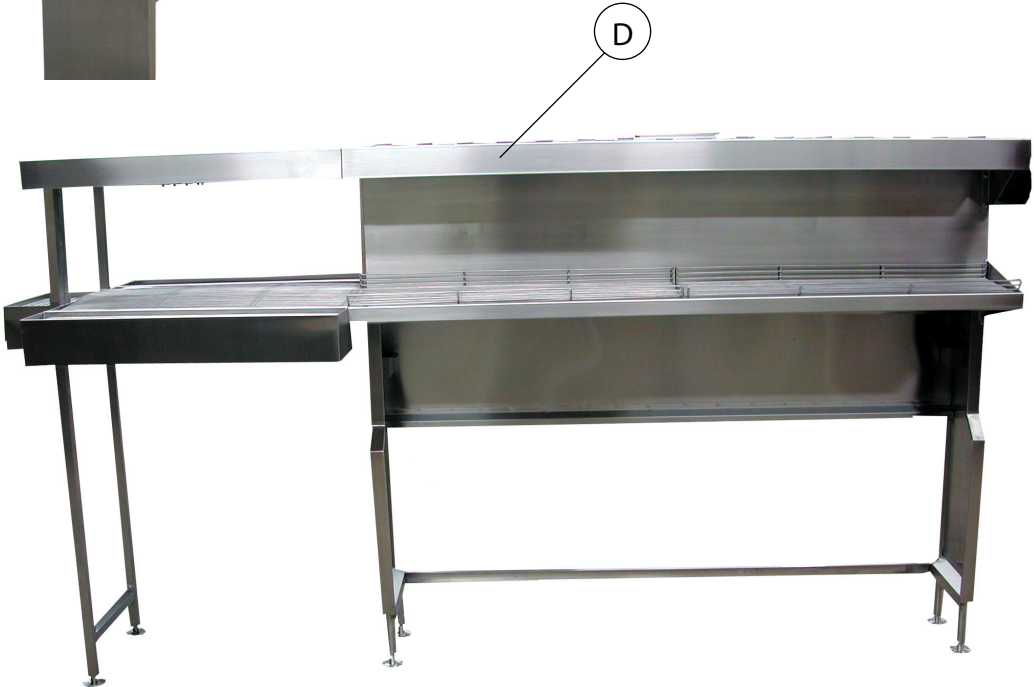

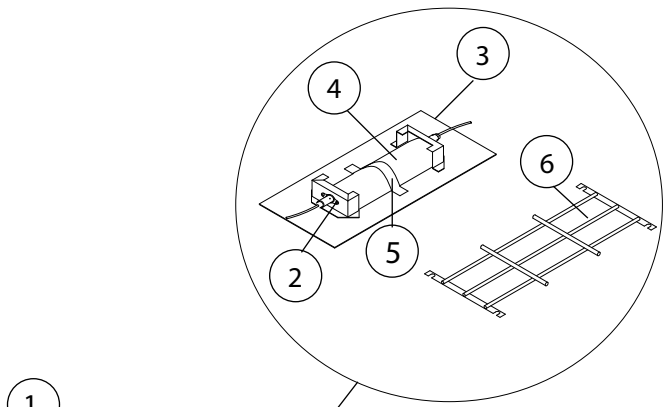

Typical Each Location

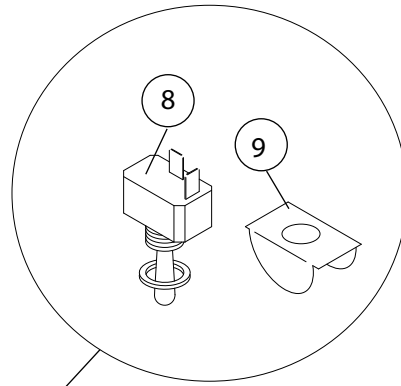
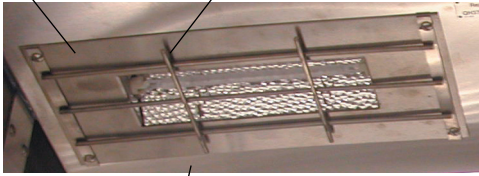

Typical Each Location



Typical Four (4) Places

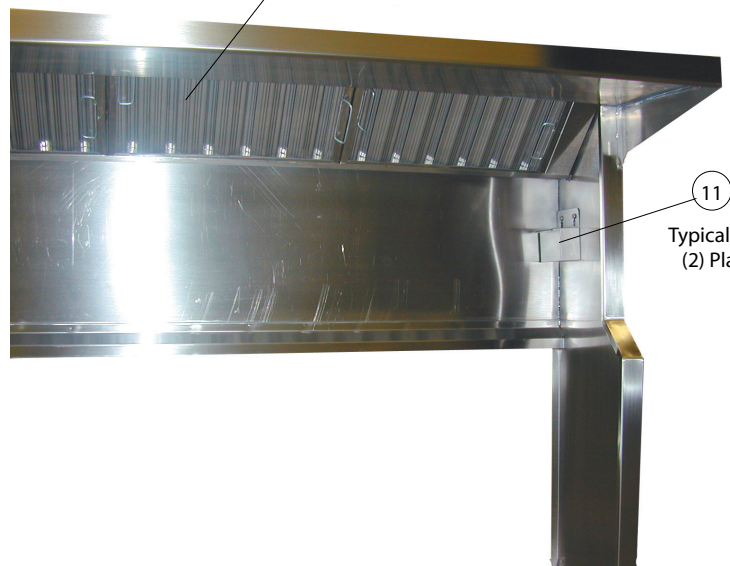

Typical Two (2) Places

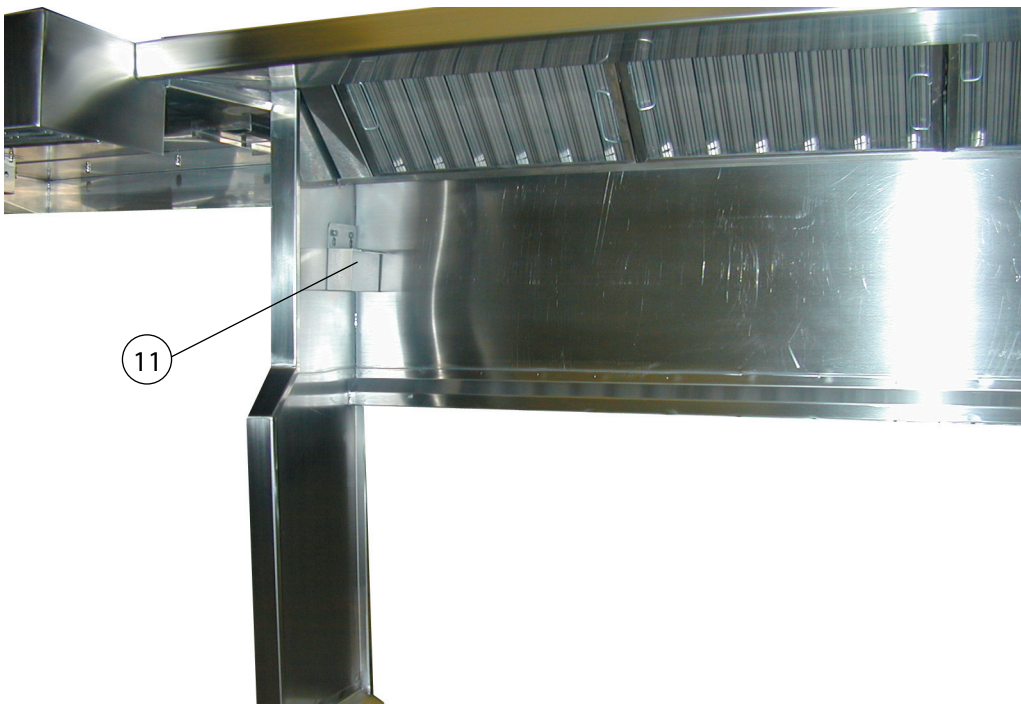

QTY	ITEM	DESCRIPTION	PART #
1	A	<u>Three (3) Window Chicken Display</u>	11B446
1	12	Chicken Display Side Wire Grill (REF: 11B446 Page 5)	SO
2	13	Chicken Display Front and Rear Grill (REF: 11B446 Page 5)	SO
1	14	Chicken Display Center Grill (REF: 11B446 Page 5)	SO
2	17	3 1/2" (89mm) Flanged Bullet Feet	22736
1	B	<u>Three (3) Window Chicken Display UPPER Light Panel Assembly</u>	NOTE 1
4	1	Quartz Warmer Lamp Assembly	12B098
8	2	GE AL 1881705 Quartz Lamp Holder	18077
4	3	Quartz Lamp Base Panel	19A711
4	4	Warmer Lamp Reflector	19B175
4	5	Warmer Lamp Strap	19003
4	6	Quartz Lamp Assembly Lamp Guard	19573
*	4	7 Replacement 120 Volt 375 Watt QH375T317 Quartz Warmer Lamp Bulb	18084
4	8	125/250 Volt 15/10 Ampere On/Off Toggle Switch	18204
4	9	Toggle Switch Guard	18129
1	C	<u>Three (3) Window Chicken Display LOWER "L" Shapped Light Panel Assembly</u>	NOTE 2
4	1	Quartz Warmer Lamp Assembly	12B098
8	2	GE AL 1881705 Quartz Lamp Holder	18077
4	3	Quartz Lamp Base Panel	19A711
4	4	Warmer Lamp Reflector	19B175
4	5	Warmer Lamp Strap	19003
4	6	Quartz Lamp Assembly Lamp Guard	19573
*	4	7 Replacement 120 Volt 375 Watt QH375T317 Quartz Warmer Lamp Bulb	18084
1	D	<u>Free Standing Exhaust Hood</u>	11B445
1	15	Free Standing Exhaust Hood Trough Exit Grill (REF: 11B445 Page 3)	SO
1	16	Free Standing Exhaust Hood Trough Grill (REF: 11B445 Page 3)	SO
4	10	Free Standing Exhaust Hood Exhaust Filter	21420
2	11	Free Standing Exhaust Hood Trough Grease Cup (REF: 11B445 Page7)	SO
4	17	3 1/2" (89mm) Flanged Bullet Feet	22736
1	E	<u>Free Standing Exhaust Hood Light Panel Assembly</u>	NOTE 3
5	1	Quartz Warmer Lamp Assembly	12B098
10	2	GE AL 1881705 Quartz Lamp Holder	18077
5	3	Quartz Lamp Base Panel	19A711
5	4	Warmer Lamp Reflector	19B175
5	5	Warmer Lamp Strap	19003
5	6	Quartz Lamp Assembly Lamp Guard	19573
*	5	7 Replacement 120 Volt 375 Watt QH375T317 Quartz Warmer Lamp Bulb	18084

* - Not Shown

NOTE 1 - When Ordering Specify as 11B446 Page 4
NOTE 2 - When Ordering Specify as 11B446 Page 6
NOTE 3 - When Ordering Specify as 11B445 Page 5

SO - Special Order Item Only

WIRING DIAGRAM

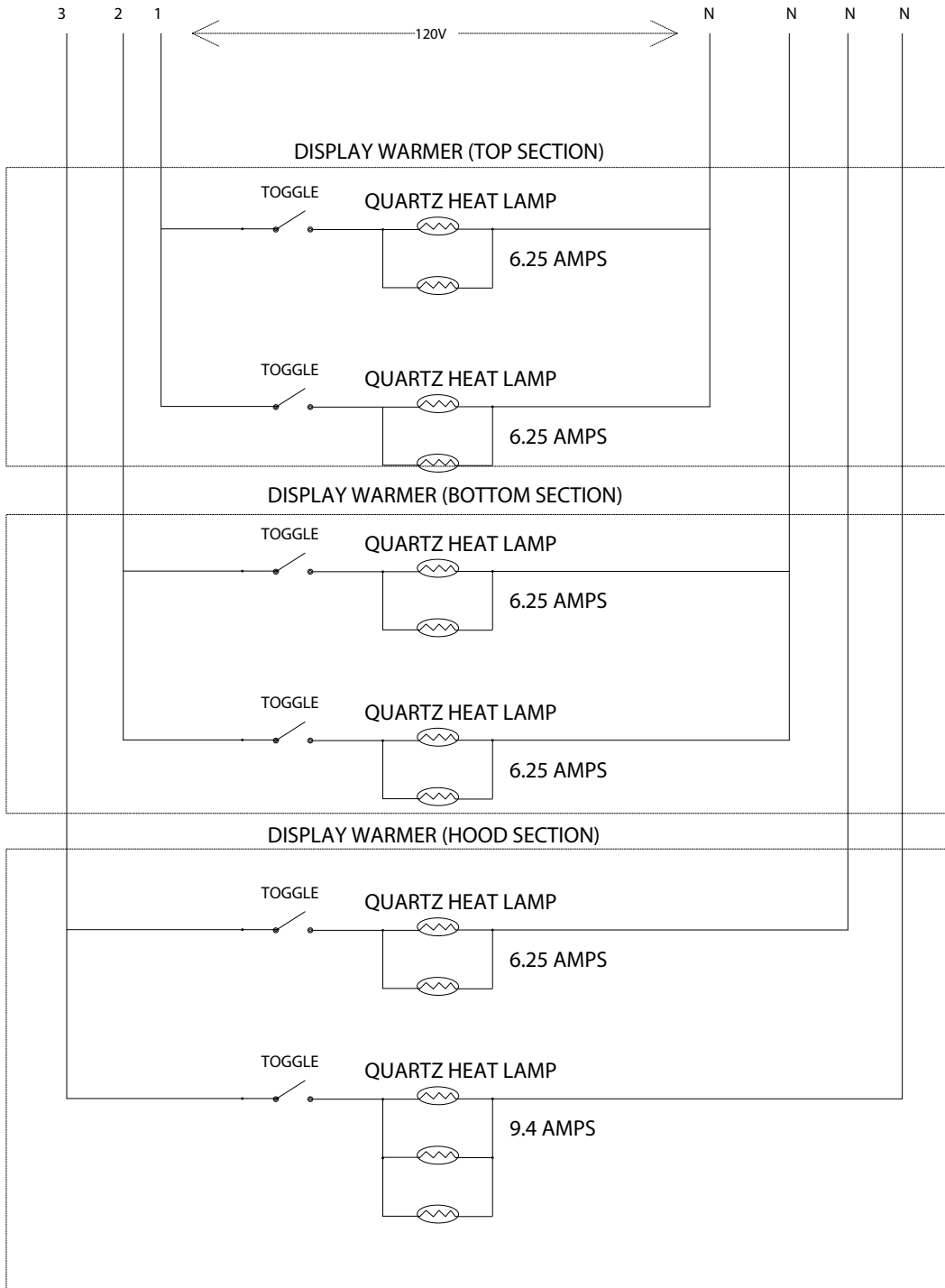

THIS PAGE INTENTIONALLY BLANK