



# ULTRAFRYER<sup>®</sup> SYSTEMS



## Model EUS & SC Electric Fryer Operation Instructions



**WARNING!!!** TO PRECLUDE THE POSSIBILITY OF SPONTANEOUS COMBUSTIBLE FILTER TUB FIRES; SLUDGE AND CRUMBS MUST BE REMOVED AND DISCARDED AND THE FILTER TUB MUST BE THOROUGHLY CLEANED AFTER CLOSING THE STORE EACH NIGHT!!!

302 Spencer Lane • P.O. Box 5369

San Antonio, Texas 78201

(800) 525-8130 • (210) 731-5000 • Fax: (210) 731-5099

## PREFACE

This manual was rewritten and published by the Technical Publications Department, Ultrafryer Systems, for use by personnel who operate an Ultrafryer Model S & SC Electric Fryer equipped with an Ultrastat 21 or Ultrastat 25 Cooking Computer.

TECHNICAL PUBLICATIONS DEPARTMENT

ULTRAFRYER SYSTEMS

302 Spencer Lane

San Antonio, TX 78201

1-800-545-9189 Ext 5007

NOTE: This manual is applicable to “Standard” Electric Model EUS & SC Bank of Fryers. It can be used as a guide in operating special variations of an Electric Model EUS & SC Bank of Fryers.

## TABLE OF CONTENTS

	Page
<b>GENERAL INFORMATION</b>	
<b>WARRANTY</b>	2
<b>SAFETY</b>	3
<b>DESCRIPTION / SPECIFICATIONS</b>	3
<b>INSTALLATION, INITIAL CLEANING, SHORTENING INSTALLATION, AND FRYER TEST START-UP</b>	
<b>INSTALLATION</b>	5
<b>GENERAL</b>	5
<b>UNPACKING</b>	5
<b>INSTALLING</b>	5
<b>LEVELING</b>	8
<b>ELECTRIC CONNECTION</b>	8
<b>CLEARANCES</b>	8
<b>INITIAL CLEANING</b>	8
<b>FRYER TEST START-UP</b>	9
<b>SHORTENING INSTALLATION</b>	11
<b>PREVENTIVE MAINTENANCE AND TROUBLE SHOOTING</b>	
<b>PREVENTIVE MAINTENANCE</b>	13
<b>TROUBLE SHOOTING</b>	13
<b>FRYER OPERATION</b>	
<b>GENERAL</b>	16
<b>FILTER TUB ASSEMBLY</b>	17
<b>ULTRASTAT 21 COOKING COMPUTER OPERATION</b>	19
<b>START-UP &amp; COOKING</b>	19
<b>FILTERING SHORTENING</b>	19
<b>SHORTENING DISPOSAL &amp; FRYER BOIL-OUT</b>	22
<b>ULTRASTAT 25 COOKING COMPUTER OPERATION</b>	25
<b>START-UP &amp; COOKING</b>	25
<b>FILTERING SHORTENING</b>	25
<b>SHORTENING DISPOSAL &amp; FRYER BOIL-OUT</b>	29
<b>INTERMEDIATE SEDIMENT FLUSH</b>	32
<b>CLEANING</b>	34
<b>SERVICE &amp; PARTS</b>	
<b>TECHNICAL ASSISTANCE</b>	38
<b>ORDERING INFORMATION</b>	38
<b>PARTS IDENTIFICATION</b>	38
<b>WIRING DIAGRAMS</b>	47

## **GENERAL INFORMATION**



## ULTRAFRYER® LIMITED WARRANTY

Ultrafryer Systems warrants to the original purchaser of a gas or electric Ultrafryer® sold within the United States, its territories and Canada, that it will be free of defects in material and workmanship for the periods listed below:

**STAINLESS STEEL FRYER VAT** – Stainless Steel fryer vats are warranted for (10) ten years upon the terms hereinafter described. The (10) ten year warranty coverage applies **ONLY** to the Stainless Steel fryer vat and does not apply to the other components such as controls, fire boxes, gaskets, mounting hardware, or the heat shield weldment. The (10) ten year limited warranty coverage for the Stainless Steel fryer vats are as follows: (1) Vats that fail due to faulty workmanship or materials within the first twelve (12) months from the date of initial start up will be exchanged at no cost. Standard delivery ground freight will be prepaid by Ultrafryer **Systems for first year failures only**. The cost of labor to install the replacement vat will be covered by Ultrafryer Systems for vats, which fail within twelve (12) months from the date of initial start up. Labor for vat replacements after the first year is the responsibility of the owner.

(2) Vats that fail within the first (18) months will be exchanged at a cost not to exceed \$100.00 FOB San Antonio. (3) Vats that fail within the first (24) months will be exchanged at a cost not to exceed \$150.00 FOB San Antonio. (4) Vats that fail within the next (8) years will be exchanged at a cost not to exceed \$200.00 FOB San Antonio. (Subject to inflation adjusted in accordance with the C.P.I.). Proper credit issue for vat failures is contingent upon receipt, by Ultrafryer Systems, of the serial number identification tag for any failed vat.

**ULTRAFRYER PARTS** – All parts on the Ultrafryer® are covered for a period of one (1) year from the initial date of start up. This is to include computers, gas valves, switches, thermostats, etc. Ultrafryer Systems reserves the right to charge for certain parts such as computers, filter pumps and motors or any item over the amount of \$100.00 until Ultrafryer Systems receives the defective part back. After inspection, credit for the part will be issued to the purchaser provided the part is deemed defective and that defect is not the result of neglect or abuse by the user. The shortening filtration system, (hoses) are warranted for ninety (90) days from the initial date of start up.

**PROCESSING WARRANTY CLAIMS** – The equipment owner must promptly notify Ultrafryer Systems Warranty Department of any alleged defects as soon as they are discovered by calling 1-800-525-8130. After such notice, the Warranty Department will perform its obligation under this warranty within a commercially reasonable period of time. If alleged defects develop after normal business hours, on weekends or on holidays the owner must call Ultrafryer Systems first at the above number. This number is monitored 24 hours a day, 7 days a week. Ultrafryer Systems will notify an authorized service agent to make repairs during normal hours or after hours. Any parts that need to be shipped back to Ultrafryer Systems will be shipped back **prepaid by the customer** marked with the processing number and to the attention of the WARRANTY DEPARTMENT.

**NON WARRANTY COVERAGE** – This warranty does not include coverage for any consequential cost of damages including, but not limited to, any loss in store sales, spoiled food products, transportation, duty or custom cost. This warranty does not cover the Ultrafryer® exported to countries outside the United States and its territories. This warranty does not cover original installation and adjustments such as leveling, calibrations, electrical and gas connections, or problems due to faulty or contaminated gas supply. This warranty does not cover travel over 100 miles or 2 hours driving time from the location of the Ultrafryer® or overtime or holiday charges unless the Warranty Department granted prior approval. This warranty does not cover damage due to misuse, abuse, alteration or accident. This Warranty does not cover improper or unauthorized repair or installation, damage in shipment, normal maintenance items such as gaskets, hoses, and exterior finishes. **Ultrafryer Systems reserves the right to void component part warranty on any Ultrafryer® that is stored more than 6 (six) months after shipment from Ultrafryer Systems and not put into service.**

**LABOR COVERAGE** – The cost for labor to replace parts are covered for one (1) year after the initial start up. This warranty will include the labor involved in the six (6) month and the twelve (12) month fryer inspections recommended by the manufacturer for the first year after initial start up. **The Warranty Department must be promptly notified of any defects within the first year of operation.** The labor warranty does not include the cost to repair or clear dirty filter systems or perform any adjustments that would normally fall under the tasks associated with a proper start up and/or demonstration. **Labor is covered by Ultrafryer Systems for repairs by an AUTHORIZED service agent.** Owner is responsible for all costs associated with fryer installation and start up unless prior arrangements have been made with Ultrafryer Systems.

### **DISCLAIMER OF WARRANTIES**

Other than as stated herein ULTRAFRYER SYSTEMS makes no warranty of any kind, express or implied, including but not limited to any warranty of merchantability of fitness for a particular purpose, including trade usage. Ultrafryer Systems sole obligation, and purchaser's sole remedy, under this warranty is repair or replacement, at the discretion of Ultrafryer Systems, of any part or component that proves to be defective in materials or workmanship. In no event shall Ultrafryer Systems be liable for consequential, incidental, or special loss or damages arising from the use of, or inability to use, the ULTRAFRYER®. This limited warranty is the only and complete statement with respect to warranties of NEW Ultrafryer® PAR-2, PAR-3 Gas and Electric ULTRAFRYERS® sold after March 1<sup>st</sup>, 2001. There are no other documents or oral statements for which Ultrafryer Systems will be responsible.

## SAFETY

The major safety factor associated with the Ultrafryer Model EUS & SC Electric Fryer is burns from hot shortening. In order to prevent serious burns, good housekeeping habits are required. The floor in front of and the area around the fryer should be kept clean and dry. Whenever anything is placed in to a fryer vat, care should be used not to splash the hot shortening. Product should always be “**PLACED**” into the shortening, not thrown. Safety goggles, neoprene insulated gloves and an apron must be worn while filtering or boiling-out a fryer vat. Extreme caution should be exercised when connecting the “Wash Down Hose’ **MALE PLUG** to the Wash Down **TOPSIDE FEMALE COUPLER** on the rear wall of the fryer vat during filtering or boil-out operations. If this plug is not securely attached to the coupler **HOT** shortening will be discharged around this connection which could cause **SEVERE BURNS**. The Ultrafryer Model EUS & SC Electric Fryer utilizes 120 volts and 208 or 240 volts, single and three phase electrical power and no adjustments or replacement of electrical controls or parts should ever be attempted without first disconnecting **ALL** electrical power. **FAILURE** to do so could result in serious electrical shock or death. Electrical power to the fryer is supplied from more than one (1) circuit breaker and it should be determined that **ALL** electrical power has been removed prior to beginning a repair. The fryer and its controls should not be operated with wet hands or while standing in water. To do so can result in serious electrical shock or death.

Fire in liquid shortening should always be a constant concern of team members operating or working nearby the Electric Fryer. The fryer should be equipped with a Fire Suppression system, that automatically **OPENS** the shunt trip circuit breakers, removing electrical power from the fryer if a fire occurs. In addition, this system **MUST** be inspected by a licensed distributor each six (6) months to assure it is operational.

## DESCRIPTION/SPECIFICATIONS

The Ultrafryer Model EUS & SC Electric Fryer is constructed from 16 and 18 gauge, type 304 polished steel. Each of the three (3) sizes of fryer are equipped with: 1) a bottom pressure sweeper to remove debris from the vat; 2) improved filter tub containing a Crumb Catcher Pan, Sludge Catcher Pan and Screen and filter tub cover to minimize spills when removing the tub from the guide rails; and 3) a central Wash Down Hose female coupler located on the center vat along with a Time Control Shortening Wash Panel. In addition, an optional automatic vat cleaner and storage caddy beneath the right side can also be purchased. The dimensions of each size fryer is as follows:

<u>ITEM DESCRIPTION</u>	<b>EUS-14</b>		<b>EUS-18</b>		<b>EUS-20</b>	
	<b>in.</b>	<b>(mm)</b>	<b>in.</b>	<b>(mm)</b>	<b>in.</b>	<b>(mm)</b>
Overall Width	15½”	(394)	19½”	(495)	21½”	(546)
Overall Depth	28¾”	(730)	38¾”	(984)	38¾”	(984)
Work Height	36”	(914)	36”	(914)	36”	(914)
Oil Capacity						
High Level		--	110 lbs	(55 liters)	138 lbs	(69 liters)
Low Level	45 lbs	(22.5 liters)	70 lbs	(35 liters)	--	
Shipping Cube	10.49ft <sup>3</sup>	(.29 m <sup>3</sup> )	18.01 ft <sup>3</sup>	(.50 m <sup>3</sup> )	19.77 ft <sup>3</sup>	(.55m <sup>3</sup> )
Shipping Weight	235 lbs	(106 kgs)	265 lbs	(119 kgs)	275 lbs	(124 kgs)
Electrical Requirements	208 / 240 Volt		208 / 240 Volt		208 / 240 Volt	
	3 Ø		3 Ø		3 Ø	
	17 KW/Vat		20KW/Vat		20 KW/Vat	

**INSTALLATION, INITIAL CLEANING, SHORTENING  
INSTALLATION AND FRYER TEST START-UP**

## INSTALLATION

**GENERAL** - Each Model EUS & SC Electrical Fryer should be installed as follows:

1. Properly unpacked and positioned at its operating location within the store.
2. Placed beneath a properly designed exhaust hood and protected by a Fire Suppression System
3. **LEVELED** using a spirit level to assure each vat contains the proper amount of shortening.
4. Installed by a licensed electrician and connected to the 1 phase and 3 phase voltages shown on the data plate.
5. Restrained by use of a restraining device to avoid splashing hot liquid and to ensure tension cannot be placed on electrical connections.

**UNPACKING** - Check that the container is upright. Use an outward prying motion. **DO NOT USE A HAMMER** to remove the wood braces and carton. Check the fryer bank for visible damage; if damage has occurred do not refuse shipment, but contact the carrier and file the appropriate freight claims. Remove the two shipping bolts in the front and rear legs and remove the two 2" x 6" (51mm x 152mm) wood supports.

**INSTALLING** - If sufficient clearance is available to roll the assembled fryer bank into the building, proceed to the **LEVELLING** paragraph below. In the event entrance doors are too narrow to roll the assembled fryer into the building; disassemble and reassemble the fryer as follows:

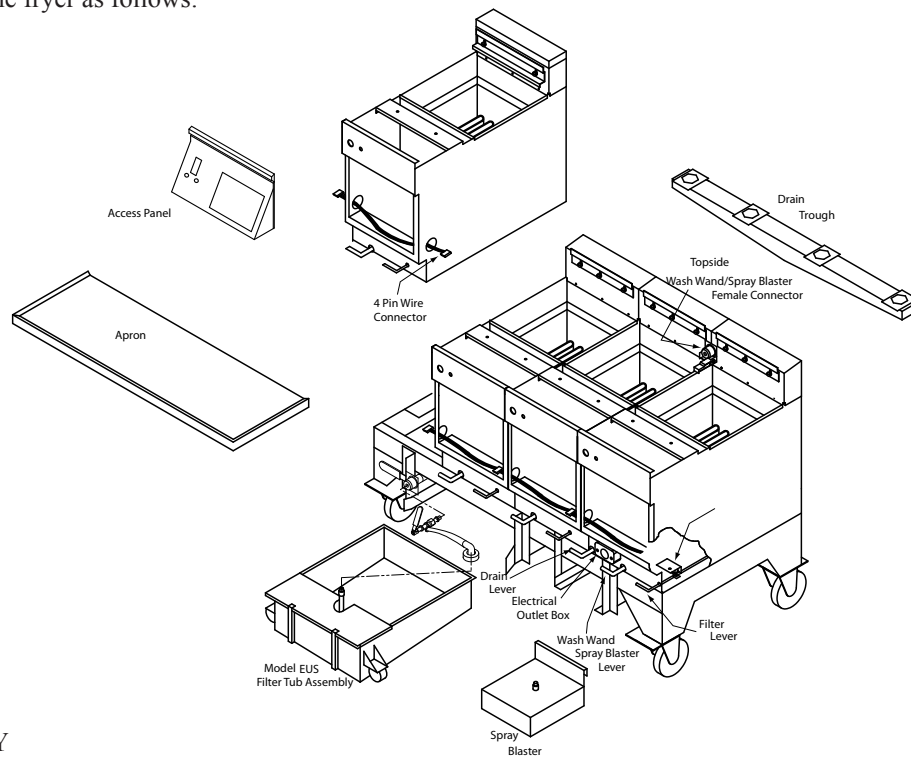

## DIS-ASSEMBLY

- A. Perform the following steps facing the **FRONT** of the fryer:
1. Number each vat cabinet from **LEFT** to **RIGHT** and place these numbers on the front and rear panel of each cabinet.
  2. Lower the Temperature Control access panel from each vat cabinet.
  3. **CAREFULLY** remove the **APRON** from the fryer bank by removing the two (2)  $\frac{1}{4}$  - 20 wing nuts,  $\frac{1}{4}$ " split washers, and  $\frac{1}{16}$ " flat washers from each  $\frac{1}{4}$  - 20 weld stud beneath each cabinet hat section.

**NOTE:** It may be necessary to cut the **SILICONE SEAL** between the apron and vat cabinets to separate the apron. **DO NOT DAMAGE THE GASKET.**

4. Remove the **JOINER STRIP** located between each set of vats; then cut the **SILICONE SEAL** between the vats.
5. **CAREFULLY** separate the **SHORTENING DRAIN TROUGH** from each 2" ball valve plate by removing the four (4)  $\frac{1}{4}$  - 20 hex head bolts and nuts; then remove the drain trough from the fryer.

**NOTE:** A neoprene gasket was placed between the ball valve and drain trough opening of each vat and sealed with silicone. Therefore it may be necessary to use a sharp instrument to separate the trough from the valve.

**DO NOT DAMAGE THE NEOPRENE GASKET.**

6. **CAREFULLY** disconnect the **4 PIN WHITE** connector from its mating receptacle located on the **LOWER** right hand end of each vat; then remove the **BLACK** wiring harness protector from the 2" opening in each vat.
7. **CAREFULLY** disconnect the **ELECTRICAL OUTLET BOX BLACK** and **WHITE** electrical wires connected to wires by **WIRE NUTS** located on the **LEFT HAND** side of the "extreme" **RIGHT HAND** vat.
8. Remove the 10 - 24 truss head screw and nut on the right hand side of each vat used to secure adjoining vats and remove the 10 - 24 truss head screw and nut that secures the "extreme" left hand vat cabinet to the base frame.

B. Perform these steps facing the **REAR** of the fryer:

1. Remove the **REAR** panel from each vat by removing the four (4) pan head self-tapping screws.
2. Remove the two (2) 10 - 24 truss head screws and nuts on the right hand side of each vat used to secure adjoining vats.

**NOTE:** It may be necessary to loosen and move the two (2) electrical contactors to gain access to these screws and nuts.

3. **CAREFULLY** remove the two (2) philips head self-tapping screws along the **BOTTOM** flange of each cabinet.
4. **CAREFULLY** disconnect the **SHORTENING LINE RED** and **WHITE** heater tape electrical wires terminated in the terminal block of the **EXTREME** right hand fryer.
5. **CAREFULLY** disconnect the **FILTER PUMP MOTOR RED, GREEN** and **WHITE** electrical wires terminated in a **4 PIN WHITE** connector from its mating receptacle located on the left hand side of the "extreme" **LEFT HAND** vat.
6. **CAREFULLY** disconnect the **POWER LINE BLACK** and **WHITE** electrical wires terminated in a **4 PIN WHITE** connector from its mating receptacle located on the left hand side of the "extreme" **LEFT HAND** vat.
7. **SECURE** the **SHORTENING LINE** to the base frame on the **LEFT HAND** end of the fryer bank; then **CAREFULLY** loosen and separate the shortening line union attached to each 3/4" ball valve.
8. **CAREFULLY** remove each cabinet from the base frame, carry each cabinet into the building; then place the base frame into position in the kitchen.
10. **PRIOR** to re-assembling the fryer bank, remove **DRIED** silicone used to seal the apron to vats, opening between each set of vats, front and rear of each cabinet, lower edge of the two (2) end vats, and perimeter of the base frame.

## **RE-ASSEMBLY**

A. Place each vat cabinet in numerical order in **FRONT** of the base frame from **LEFT** to **RIGHT**.

B. Install each vat cabinet on the base frame as follows:

1. Place a bead of silicone around the perimeter of the base frame for the **FIRST** vat cabinet.
2. **CAREFULLY** place **VAT CABINET #1** in position on the base frame; then secure the cabinet to the base frame by installing a 10 - 24 truss head screw and nut on the left hand flange to the base frame then install two (2) philips head self-tapping screws in the two holes on the **REAR** bottom flange of the cabinet.
3. Repeat the above procedures to install remaining vat cabinets on the base frame.

C. When all vat cabinets are installed on the base frame, secure the cabinets as follows:

1. Place a bead of silicone along the **FRONT, TOP** and **REAR** space between vat cabinets #1 and #2.
2. Install a 10-24 truss head screw and nut in the 1/4" holes on the **FRONT** right hand side of vat cabinet #1 and left hand side of vat cabinet #2.
3. Install two (2) 10-24 truss head screws and nuts in the two (2) 3/16" holes on the **REAR** left hand side of vat cabinet #1 used to secure it to cabinet #2.
4. Repeat the above procedures to secure remaining vat cabinets to adjoining vat cabinets.

D. Perform these steps facing the **REAR** of the fryer:

1. **CAREFULLY** connect each shortening line union **HAND TIGHT**, remove the device used to secure the **SHORTENING LINE** to the **LEFT** end of the base frame; then **SECURELY** tighten each shortening line union.

2. **SECURELY** connect the **SHORTENING LINE RED** and **WHITE** heater tape electrical wires to the Black and White wire terminals on the Terminal Block of the **EXTREME** right vat.
3. **SECURELY** connect the **FILTER PUMP MOTOR RED, GREEN** and **WHITE** electrical wires terminated in a **4 PIN WHITE** connector to its mating receptacle located on the left-hand side of the “extreme” **LEFT HAND** vat.
4. **SECURELY** connect the **POWER LINE BLACK** and **WHITE** electrical wires terminated in a **4 PIN WHITE** connector to its mating receptacle located on the left hand side of the “extreme” **LEFT HAND** vat.
5. Install a large cabletye on the cable harness on the “extreme” **LEFT** and **RIGHT** vats; then replace the **REAR PANEL** on each vat cabinet using four (4) pan head self-tapping screws in each cabinet panel and fan cover.

E. Perform these steps facing the **FRONT** of the fryer:

1. Install the **BLACK** wiring harness protector in the 2” opening of each vat; then **SECURELY** connect the **4 PIN WHITE** wiring harness connector to its mating receptacle on each vat.
2. **CAREFULLY** connect the **ELECTRICAL OUTLET** box **BLACK** and **WHITE** wires on the “extreme” right hand vat to the **POWER** line **BLACK** and **WHITE** wires using the wire nuts previously removed.
3. Remove any dried silicone from the **SHORTENING DRAIN TROUGH**, place a bead of silicone to the same location on the drain trough, position the drain trough beneath the fryer; then **SECURE** the drain trough to each 2” ball valve plate using four (4) ¼ - 20 hex head bolts and nuts previously removed.
4. Remove any dried silicone from each **JOINER STRIP**, place a bead of silicone in each strip; then place the joiner strip over the edge of all adjoining fryer vats.
5. **CAREFULLY** replace the **APRON** as follows:
  - a. Remove any dried silicone from the front edge of each vat cabinet and the bottom of the **APRON**.
  - b. Place a bead of silicone along the **FRONT** edge of each vat cabinet and fill the **REAR** corners of the apron with silicone so it will be flush with the top of the apron.
  - c. Place the apron in position with the **REAR** flange towards the **FRONT** inside edge of each vat and the **FRONT** of the apron, elevated approximately 45 degrees; seat the rear flange of the apron over the front inside edge of each vat; then **CAREFULLY** lower the front of the apron until each ¼ - 20 weld stud is seated in the notches of the front and rear hat section of each cabinet. Slip the apron a little bit to the left and right to center it on the fryer.
  - d. When the apron is properly positioned, secure it to the hat sections of each cabinet using the wing nuts, split washers and the flat washers removed earlier.
  - e. After the apron has been secured to each fryer cabinet, apply a small bead of multi-purpose sealant to the areas shown in the sketch below.

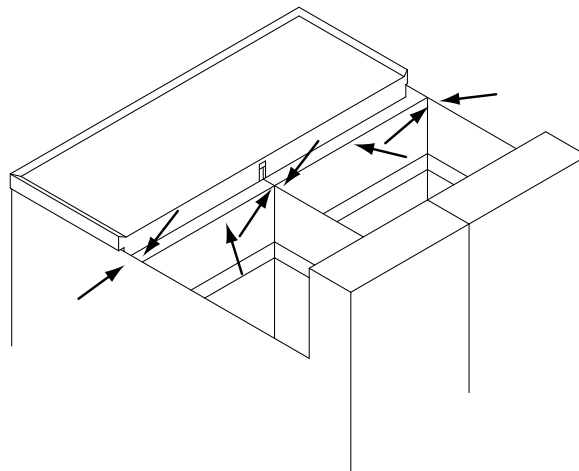

6. Replace the Temperature Control Access Panel.

**LEVELING** - After the Ultrafryer Electric Fryer has been properly positioned in the store, it should be **LEVELED** using a Spirit Level by inserting the appropriate number of shim plates between each leg and caster plate. Leveling will assure that each vat contains the same amount of shortening when checked at the engraved shortening level mark on the rear wall of the fryer vat.

**ELECTRICAL CONNECTION** - Each Model EUS&SC Ultrafryer Electric Fryer is wired internally to operate on 120 volt single phase and 208 or 240 volt 3 phase electrical power as shown on the fryer's rating plate and in the illustration below. The 120 volt control circuit of each individual fryer in a bank of fryers are internally wired in parallel to an eight (8) foot 120 volt electrical cord with a molded electrical plug. The 208 or 240 volt 3 phase circuit of each fryer in a bank of fryers is internally wired to a **SEPARATE** terminal block which is to be used to connect to the building power source. It is **ESSENTIAL** that the 120 volt electrical receptacle is located within 8 feet of the fryer bank location and that provisions are made so that the fryer bank can be moved to service fryers from the rear. Electrical connections to the fryer bank should be made by a licensed electrician and they must conform to the **NATIONAL ELECTRICAL CODE** as well as to local electrical codes and/or ordinances. To avoid electrical hazards and assure proper operation of the electric fryer, the following precautions should be observed during installation:

- A. **MATCH VOLTAGE:** Before connecting electrical power, insure the line voltage matches the voltage rating on the fryer's Data plate.
- B. **CIRCUIT BREAKERS:** The fryer must be connected to a circuit having shunt-trip circuit breakers sized in accordance with requirements of the National Electrical Code as well as local codes and ordinances.
- C. **ELECTRICAL CONNECTION:** It is **ESSENTIAL** that one of the **LOW LEGS** (120 volts to neutral) of the building's 208 or 240 volt power source, shown below, be connected to high voltage terminal **L1**, identified below, for proper operation of the 120 volt heat element indicator lamp.

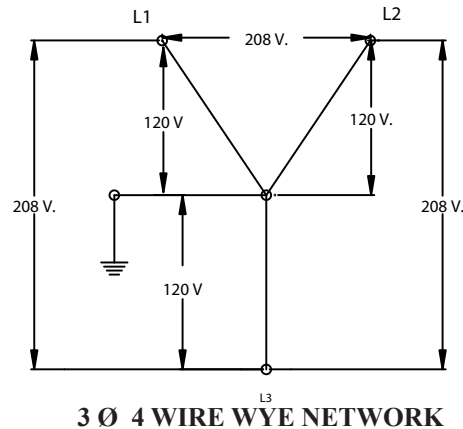
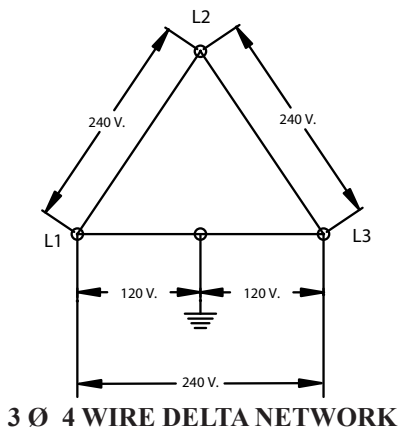

- D. **GROUNDING:** The fryer **MUST** be grounded to the building ground system according to the National Electrical Code and local codes/ordinances.
- E. **FIRE PROTECTION:** The fryer should be installed beneath a powered exhaust hood which complies with NFPA96 standards that is equipped with an approved Fire Suppression System designed to automatically shut-off all sources of electrical power to the fryer in case of a vat fire.

**CLEARANCES** - The Model EUS & SC Electric Fryer **MUST** be kept free and clear of all combustibles. The **MINIMUM** clearances from combustible and non-combustible construction is 6" (152 mm) from the sides and 6" (152 mm) from the rear of the fryer. The fryer may be installed on combustible floors.

## INITIAL CLEANING

New Electric Fryers are wiped clean with solvents at the factory to remove any visible signs of dirt, oil, grease, etc. remaining from the manufacturing process; then given a light coat of oil. Each fryer and filter tub assembly should be **THOROUGHLY** washed with **HOT** sanitizer solution to remove film residue, installation dust or debris and then wiped dry prior to placing the fryer into operation.

## FRYER TEST START-UP

A. **TO TEST OPERATE** an Ultrafryer Electric Fryer equipped with an Ultrastat 21 Cooking Computer:

1. Ensure the fryer's power ON/OFF Switch is in the OFF position.
2. Fill the fryer vat with hot or cold water to the middle of the "E<--" in the word **LEVEL** of the applicable shortening level mark on the rear of the vat.
3. **ENSURE** the **EXHAUST FAN** is **ON**.
4. Perform the following steps, in the order listed:

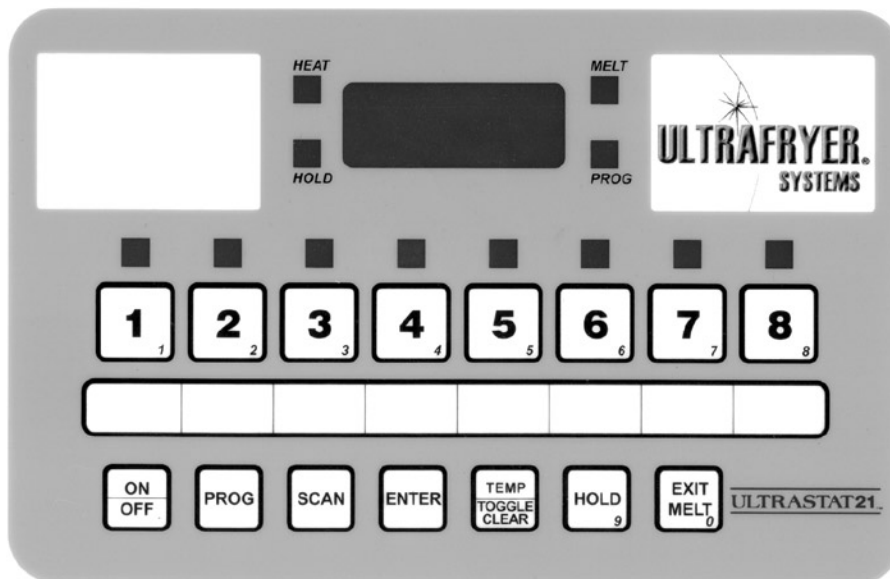

<u>STEP</u>	<u>ACTION</u>	<u>RESPONSE</u>
1	<b>ENSURE</b> the drain lever on the fryer is in the <b>CLOSED</b> position, water is at the proper level, then turn the fryer <b>TOGGLE ON/OFF</b> switch to the <b>ON</b> position.	A. The <b>AMBER</b> Power lamp beside the <b>TOGGLE ON/OFF</b> switch will <b>LIGHT</b> .
<b>CAUTION: PRIOR TO PROCEEDING TO STEP 2 VISUALLY CHECK THAT THE HEAT MECHANISM IS COVERED WITH AT LEAST 2" (51 mm) OF WATER.</b>		
2	Turn the Computer <b>ON</b> by depressing the computer ON/OFF button; then place the computer in the <b>BOIL MODE</b> by pressing the computer keys in the following order: <b>PROG , 1 , 7 , 3 , 3 , ENTER</b> .	A. <b>BOIL</b> will appear in the computer display. B. The <b>HEAT</b> lamp on the computer and the <b>RED</b> heat mechanism indicator lamp on the fryer will cycle <b>ON</b> and <b>OFF</b> indicating the heat mechanism is periodically being turned <b>ON</b> and <b>OFF</b> to gently heat the water to <b>190°F (88°C)</b> .
3	When the water begins to <b>BOIL</b> , press the following computer keys in the order shown to <b>EXIT</b> the <b>BOIL MODE: PROG , 1 , 7 , 3 , 3 , ENTER</b> .	A. <b>LO</b> will appear in the computer display. B. The <b>HEAT</b> lamp on the computer will turn <b>OFF</b> . C. The <b>MELT</b> lamp on the computer will <b>LIGHT</b> .
4	Turn the computer <b>OFF</b> by depressing the ON/OFF button; then turn the fryer Toggle ON/OFF switch to the <b>OFF</b> position.	A. The computer display will go <b>BLANK</b> . B. The <b>AMBER POWER</b> lamp will turn <b>OFF</b> .
5	After the water in the vat and metal surfaces of the fryer has <b>COOLED</b> , drain the water into a floor drain.	

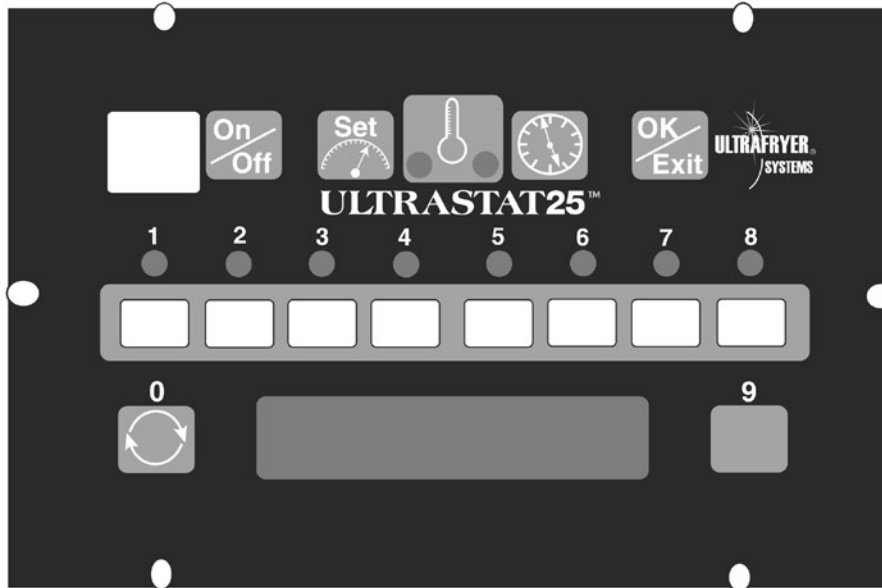

**B. TO TEST OPERATE** an Ultrafryer Electric Fryer equipped with an Ultrastat 25 Cooking Computer:

1. Ensure the fryer’s power ON/OFF Switch is in the OFF position.
2. Fill the fryer vat with hot or cold water to the middle of the “E<--” in the word **LEVEL** of the applicable shortening level mark on the rear of the vat.
3. **ENSURE** the **EXHAUST FAN** is **ON**.
4. Perform the following steps, in the order listed:

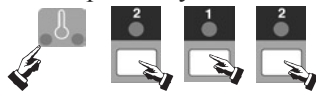

<u>STEP</u>	<u>ACTION</u>	<u>RESPONSE</u>
1	Ensure the drain valve lever is in the closed position and that water is at the proper level; then turn the Toggle ON/OFF switch to the <b>ON</b> position.	The <b>AMBER</b> power lamp beside the Fryer Toggle ON/OFF switch will <b>LIGHT</b> .

**CAUTION: PRIOR TO PROCEEDING TO STEP 2, VISUALLY CHECK THAT THE HEAT EXCHANGER TUBES ARE COVERED BY AT LEAST 2” (51mm) OF WATER.**

2	Turn the computer <b>ON</b> by depressing the computer ON/OFF key; then place the computer in the <b>BOIL MODE</b> by pressing the computer keys below in that order: 	A. <b>BOIL 30:00</b> will appear in the computer display. B. The <b>HEAT DEMAND LED</b> on the computer and the <b>RED</b> Heat Mechanism indicator lamp on the fryer will cycle <b>ON</b> and <b>OFF</b> to heat the water to <b>192°F (89°C)</b> .
3	When water begins to <b>BOIL</b> , press the computer key to exit the Boil Mode. 	A. The Computer Display will go <b>BLANK</b> .
4	Turn the Fryer Toggle ON/OFF switch to the <b>OFF</b> position.	A. The <b>AMBER</b> power lamp will turn <b>OFF</b> .
5	After the water in the vat and metal surfaces of the fryer has <b>COOLED</b> , drain the water into a floor drain.	

## SHORTENING INSTALLATION

- A. **LIQUID SHORTENING:** When using liquid shortening (cooking oil) fill the fryer with shortening even with the middle line of the **E <** in the word **LEVEL** of the applicable shortening level mark on the rear wall of the fryer.
- B. **SOLID SHORTENING:**
- 1) Cut a block of solid shortening into small pieces.
  - 2) Place small pieces of solid shortening **EVENLY** on top of the **HEAT MECHANISM** or **THOROUGHLY PACK** these pieces of solid shortening between, below and above the **HEAT MECHANISM**.  
While packing solid shortening is messy and time consuming, it is the safest and fastest way to melt solid shortening.
  - 3) Ultrastat 21 equipped Fryer
    - a) Turn the fryer Toggle ON/OFF switch **ON**; then place the computer in the **SHORTENING MELT MODE** by depressing the ON/OFF button. The **MELT** lamp will **LIGHT** to indicate the computer is in the **SHORTENING MELT MODE**; and the **HEAT** lamp and **RED** heat mechanism indicator lamp on the fryer will cycle **ON** and **OFF** indicating the heat mechanism is periodically being turned **ON** and **OFF** to gently heat the shortening.
    - b) When the heat mechanism is **COMPLETELY** covered with **LIQUID** shortening and the shortening is **ABOVE** the Melt Limit Temperature, replace the grill in the fryer vat; then push the **EXIT MELT** button on the computer. Proceed to Paragraph B 5) below.
  - 4) Ultrastat 25 equipped Fryer
    - a) Turn the fryer Toggle ON/OFF switch **ON**; then place the computer in the **SHORTENING MELT MODE** by depressing the ON/OFF key. **MELT E, G, or P** will appear in the computer display indicating the computer is in the **SHORTENING MELT MODE**; and the **HEAT DEMAND LED'S** on the computer and the fryer's **RED INDICATOR LAMP** will cycle ON and OFF indicating the heat mechanism is periodically being turned **ON** and **OFF** to gently heat the shortening.
    - b) When the heat mechanism is **COMPLETELY** covered with **LIQUID** shortening and the shortening is **ABOVE** the Melt Release Temperature, replace the grill in the fryer vat; then push the **OK/EXIT** key on the computer.
  - 5) Continue adding solid shortening as follows:
    - a) Place small pieces of solid shortening into a fry basket.
    - b) **CAREFULLY** lower the basket into the fryer vat.
    - c) **GENTLY** turn the basket to allow these pieces of solid shortening to float away.
    - d) Repeat the above steps until liquid shortening is even with the middle line of the "**E <**" in the word **LEVEL** of the applicable shortening level mark on the rear wall of the fryer vat.

### **WARNING!!! TO AVIOD INJURY**

- I DO NOT MOVE A FRYER FILLED WITH HOT LIQUID.**
- II ALWAYS WEAR OIL-PROOF, INSULATED GLOVES WHEN WORKING WITH A FRYER FILLED WITH HOT OIL.**
- III ALWAYS DRAIN HOT OIL INTO A METAL TUB, POT OR CAN ... HOT OIL CAN MELT PLASTIC BUCKETS OR SHATTER GLASS.**

**PREVENTIVE MAINTENANCE  
AND TROUBLESHOOTING**

## PREVENTIVE MAINTENANCE

Minimal maintenance is required on a fryer because of its design and materials used in manufacture. However, some preventive maintenance and inspection must be performed periodically to prevent break downs which could curtail food sales. Any preventive maintenance or inspection should be accomplished with **CAUTION** while the fryer is in operation since **HOT** liquid shortening could cause severe burns. If service or repair is required, all electrical power **MUST BE TURNED OFF PRIOR TO** performing that service or repair.

### PREVENTIVE MAINTENANCE SCHEDULE

<u>ITEM</u>	<u>DAILY</u>	<u>INSPECT FOR:</u>
Grease Filters		Clean grease filters in the exhaust hood each evening and allow them to dry overnight.
Filter Tub		Thoroughly clean the filter tub assembly as perscribed on page 29 of the Cleaning Section of this manual.  <b>ENSURE THE WASH DOWN HOSE IS HUNG IN AN UPRIGHT POSITION (BY ONE END) SO SHORTENING CAN DRAIN INTO A CONTAINER!</b>
	<u>WEEKLY</u>	
Drain/Filter Pump Valve Levers		Determine that the drain and pump levers are securely attached to the drain and pump valves, and that the valves can be easily opened and closed.
Drain Hoses		Inspect the suction line hose, wash down hose and if applicable the shortening disposal hose for any evidence of deterioration.
Plumbing Heat Tape Insulation		Ensure that insulation and electric heat tape wrapped around the plumbing directly behind the drain trough has not been damaged.
Temperature Sensing Probes		During boil-out of the fryer, inspect the temperature and high limit sensing probes for any visual damage.

## TROUBLESHOOTING

- A. GENERAL:** The problems and possible solutions listed in the troubleshooting chart below are typical Problems that are frequently encountered. **ONLY** qualified repairmen are to use the troubleshooting chart to repair this fryer. In the event an electrical malfunction occurs, perform the following checks **PRIOR** to contacting a repairman:
1. Ensure high voltage circuit breakers are in their proper position.
  2. Check that the fryer electrical plug is connected to an electrical receptacle.
  3. Ensure the applicable Circuit Breaker is in the **ON** position and that the Toggle ON/OFF Switch is in the **ON** position, and computer is "Powering Up".

- B TROUBLESHOOTING CHART:** Should a problem occur that cannot be corrected after performing the above **CHECKS**, contact an authorized repairman and/or Ultrafryer Systems Customer Service at 1-800-525-8130 and provide the information acquired while performing these checks.

**CAUTION: ENSURE REPAIRMEN ARE ADVISED THAT FRYER RESTRAINTS MUST BE DISCONNECTED/ CONNECTED IF A FRYER IS TO BE MOVED DURING MAINTENANCE OR REPAIR AND THAT ELECTRICAL POWER AND/OR GAS MUST BE TURNED OFF PRIOR TO PERFORMING ANY MAINTENANCE OR REPAIR.**

TROUBLE SHOOTING CHART		
PROBLEMS		POSSIBLE SOLUTIONS
<b>General</b>		
A	The Filter Pump Motor fails to operate when the Pump Lever is placed in the <b>OPEN</b> position and the Toggle ON/OFF Switch is in the <b>OFF</b> position.	1 Insure the filter pump micro-switch is operational, then check the manual reset button on the filter pump motor. <b>WARNING!!! TURN THE PUMP LEVER HANDLE TO THE CLOSED POSITION PRIOR TO DEPRESSING THE RESET BUTTON. FAILURE TO PLACE THIS HANDLE IN THE CLOSED POSITION COULD RESULT IN SEVERE BURNS FROM HOT COOKING OIL!</b> 2 If the filter pump motor fails to operate after the reset button has been depressed, repair or replace the motor.
B	Decreased shortening flow rate while filtering.	1 Check for excessive sediment on the filter screen, standpipe suction fitting or in the filter tub.
C	Pump / Motor operates but does not pump shortening.	1 Check for congealed shortening in the shortening system. 2 Check that the Standpipe is seated in the Knurl Knob. 3 Check for loose Standpipe / Suction Line Coupler connection.
D	Pump / Motor hums but will not pump shortening.	1 Check for congealed shortening in the pump or in shortening plumbing.

<b>Electric Fryer</b>														
A	Excessive smoke from the shortening.	1 Check the Computer Program to ensure the Pre-Set Cook Temperature is correct. 2 Shortening breakdown has occurred. Replace the shortening												
B	Process Contactor chatters.	1 Check and / or tighten the Contactor Coil connections. 2 Defective Contactor. Replace the Contactor.												
C	Excessive time is required to raise the shortening to cooking temperature. Temperature recovery is slow.	1 Check 3 Ø 208 / 240 Voltage applied to Heat Element. 2 Defective Heat Element ( <b>SEE NOTE</b> )												
D	Decreased shortening flow rate while filtering	1 Check for excessive sediment on the Filter Screen, Standpipe Suction fitting or in the Filter Tub.												
<p><b>NOTE:</b> The most effective means to determine if a Heat Element is operational is to measure the Current Draw of an Element with an Amp Probe. The Current drawn by a good Heat Element should be close to the values shown below:</p> <table style="width: 100%; border: none;"> <thead> <tr> <th style="text-align: center;"><u>INPUT ELECTRICAL SERVICE</u></th> <th colspan="2" style="text-align: center;"><u>CURRENT TO ONE HEATING ELEMENT</u></th> </tr> <tr> <th style="text-align: center;"></th> <th style="text-align: center;">14" VAT</th> <th style="text-align: center;">18/20" VAT</th> </tr> </thead> <tbody> <tr> <td style="text-align: center;">208 VOLTS</td> <td style="text-align: center;">23.6 AMPERES</td> <td style="text-align: center;">27.8 AMPERES</td> </tr> <tr> <td style="text-align: center;">240 VOLTS</td> <td style="text-align: center;">20.4 AMPERES</td> <td style="text-align: center;">24.0 AMPERES</td> </tr> </tbody> </table>			<u>INPUT ELECTRICAL SERVICE</u>	<u>CURRENT TO ONE HEATING ELEMENT</u>			14" VAT	18/20" VAT	208 VOLTS	23.6 AMPERES	27.8 AMPERES	240 VOLTS	20.4 AMPERES	24.0 AMPERES
<u>INPUT ELECTRICAL SERVICE</u>	<u>CURRENT TO ONE HEATING ELEMENT</u>													
	14" VAT	18/20" VAT												
208 VOLTS	23.6 AMPERES	27.8 AMPERES												
240 VOLTS	20.4 AMPERES	24.0 AMPERES												

## **FRYER OPERATION**

**GENERAL** - The filtration system of a Model EUS & SC and SC Electric Fryer are identical, except the Model SC fryer is also equipped with an Automatic Vat Cleaner (AVC), referred to as a “Spray Blaster”, and an AVC storage caddy beneath the right side of the fryer. Features unique to Model EUS & SC and SC fryers consist of the following:

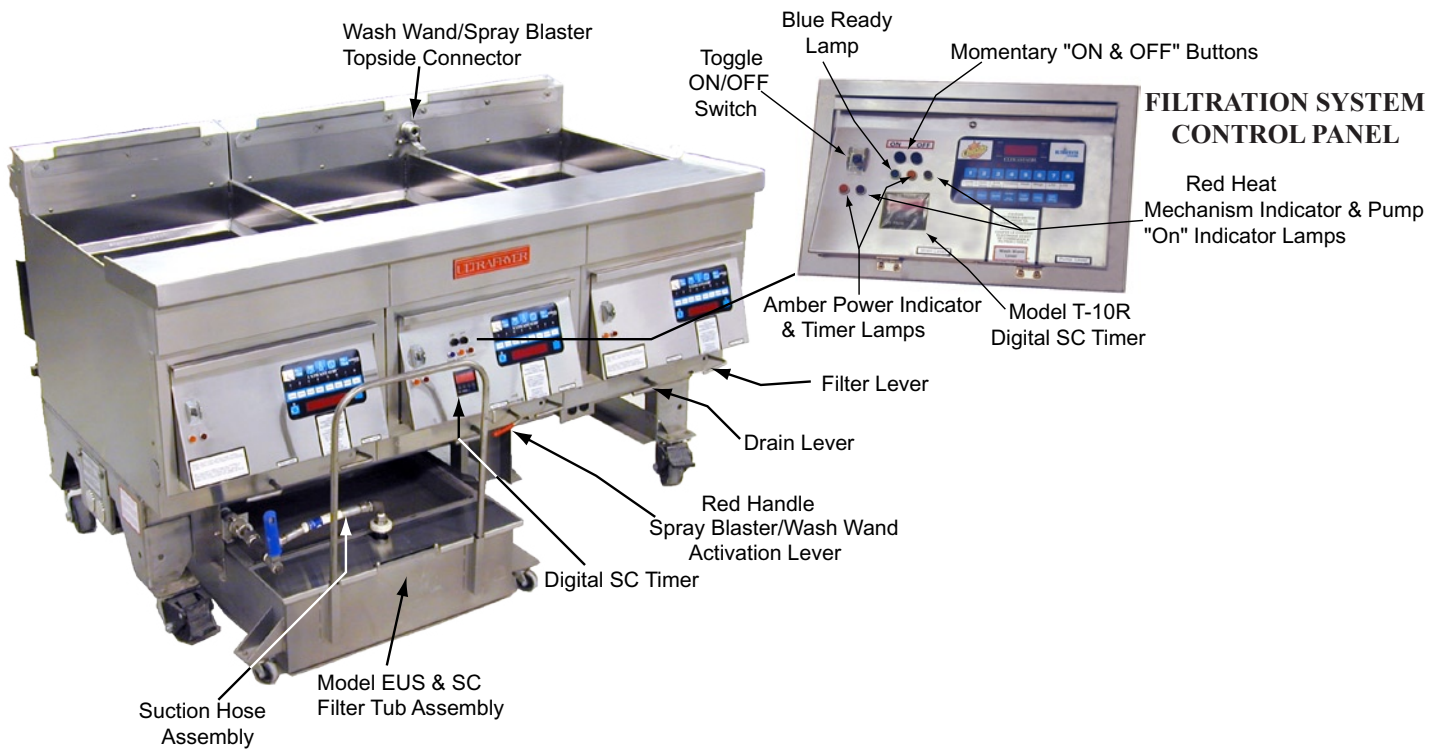

- A. **FILTRATION SYSTEM CONTROL PANEL** - This assembly consist of an “OPTIONAL” **DIGITAL SC TIMER**; a momentary **ON** button switch and a momentary **OFF** button switch; and a **BLUE, AMBER, and RED** snaplight. The **BLUE** “OPEN” lamp **LIGHTS** when the **RED** handle Spray Blaster/Wash Wand Activation Lever is turned to the **DOWN (ON)** position; the **AMBER** “READY” lamp **LIGHTS** when the momentary **ON** button switch is depressed; and the **RED** “PUMP” lamp **LIGHTS** when the **ON** button on the Control Panel and/or Digital Timer is depressed.

**NOTE:** Filtration Systems **WITHOUT** a **DIGITAL SC TIMER** uses the Ultrastat 21 Cooking Computer for the “timer”.

- B. **RED HANDLE SPRAY BLASTER/WASH WAND ACTIVATION LEVER** - When the **RED** handle Spray Blaster/Wash Wand Activation Lever is in the **UP (OFF)** position, shortening in the filter tub will be returned to a vat through the **SPRAY SWEEPER** nozzle located on the rear wall near the button of the vat to **FLUSH** sediment and debris towards the vat drain. When the **RED** handle Spray Blaster/Wash Wand Activation Lever is in the **DOWN (ON)** position shortening in the filter tub will be returned to a vat through the **TOPSIDE** connector identified above, provided 1) **ALL** other vat **PUMP LEVERS** are in the **UP (OFF)** position 2) the **ON** button on the Control Panel has been depressed, lighting the **RED** “PUMP” lamps.

- C. **WASH WAND / SPRAY BLASTER** - The Wash Wand Assembly and “optional” Spray Blaster is used to **CLEAN** sediment and debris from the heat mechanism and sides of the vat. The Wash Wand consist of the **HANDLE/NOZZLE** assembly and a six (6) ft. (1829 mm) hose for use with either the **HANDLE NOZZLE** assembly and/or the optional **SPRAY BLASTER** which contains four (4) nozzels pointed downward when it is properly installed on a bracket to the rear of the fryer.

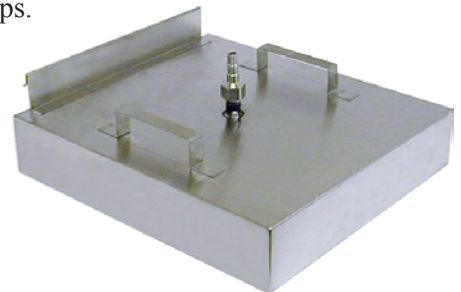

**NOTE:** This item and its storage caddy is only provided with a SC Model Fryer.

**FILTER TUB ASSEMBLY** - The Model SC Filter Tub Assembly consist of a “Micro-Mesh Stainless Steel Filter” or a “Magnapad Paper Envelope Filter”; and a Crumb Catcher Pan, Sludge Catcher Pan and Screen, Filter Tub Handle, Filter Tub Cover, and Filter Tub as well as, a two (2) piece Wash Down Hose Assembly shown below:

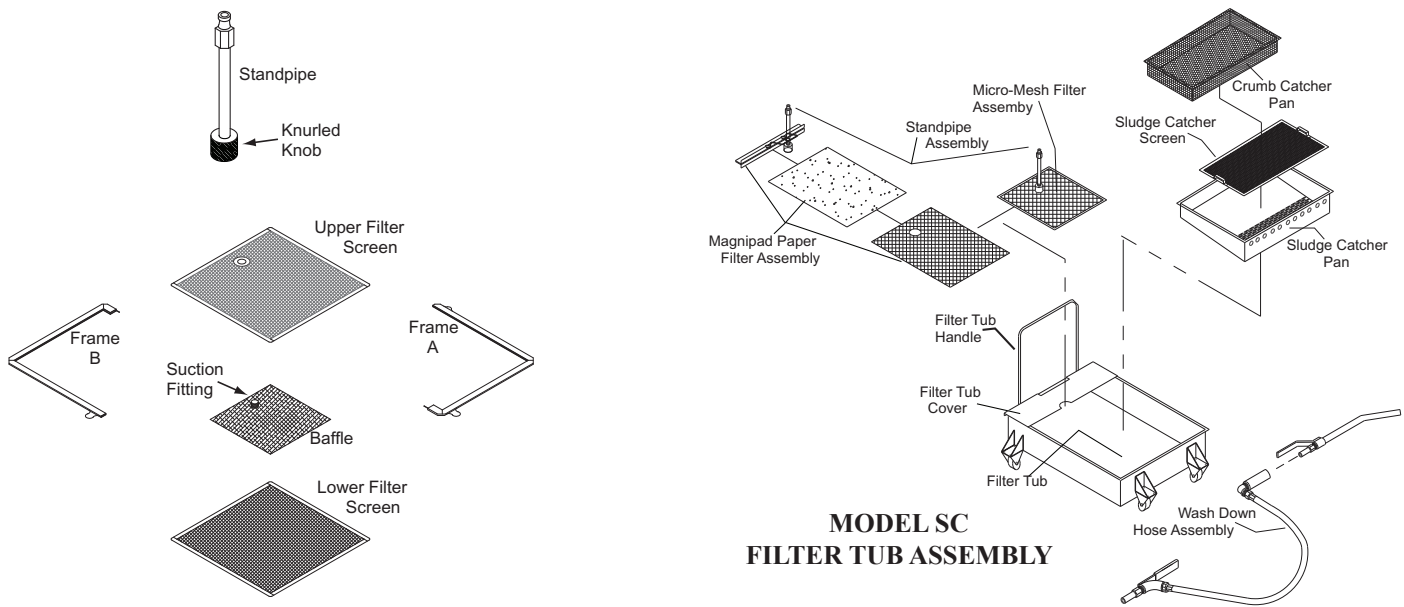

A. Assemble a clean Filter Screen as follows:

1. “Micro-Mesh” Stainless Steel Filter Screen

- a. Insert the **SUCTION FITTING** on the **BAFFLE** in the hole of the **UPPER FILTER SCREEN**; then place these items on top of the **LOWER FILTER SCREEN**.
- b. **ENSURE** all sides of the **FILTER SCREEN** assembly are aligned, place the **PIN** end of **FRAME A** on the **FILTER SCREENS**, place the **CHANNEL** on the frame adjacent to the **PIN** end over the **FILTER SCREENS**; then **HINGE** the frame so the edge of the **FILTER SCREENS** are inserted in the other **CHANNEL** of **FRAME A**.
- c. Place the **PIN** end of **FRAME B** on the **FILTER SCREENS** so the **PIN** is seated in the **CHANNEL** of **FRAME A** near the **FINGER LOOP**, place the **CHANNEL** on the frame adjacent to the **PIN** end over the edge of the **FILTER SCREENS**; then **HINGE** the frame so the edge of the **FILTER SCREENS** are inserted in the other **CHANNEL** of **FRAME B** and the **PIN** of **FRAME A** is seated in the **CHANNEL** of **FRAME B**.
- d. Adjust **FRAME A** and **B** so both **PINS** are properly seated in the **CHANNEL** of the opposite frame; then **CAREFULLY** connect the **KNURL KNOB** attached to the **STANDPIPE** to the **SUCTION FITTING** on the **FILTER SCREEN** assembly. **DO NOT OVERTIGHTEN !**

2. “Magnapad Paper Envelope” Filter

- a. Insert the **BAFFLE** into the **FILTER PAD ENVELOPE**, when inserted properly the **SUCTION FITTING** will protrude through the hole in the pad.
- b. Fold **FLAP** over (in the direction of the hole), securing the **Baffle** inside the **FILTER PAD ENVELOPE**.
- c. **CAREFULLY**, align the **CLIP & STANDPIPE ASSEMBLY** so that the **CLIP** can secure the **FLAP** on the **Envelope** and the **STANDPIPE** will align over the **SUCTION FITTING** protruding through the **Envelope**.
- d. Tighten the **Knurled NUT** on the **STANDPIPE** on the **SUCTION FITTING** protruding through the **Envelope**.

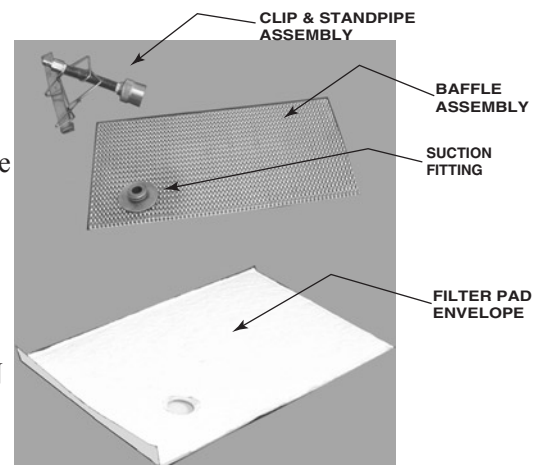

B. Re-Assemble the Filter Tub as follows:

1. Make sure the CRUMB CATCHER PAN, SLUDGE CATCHER PAN, and SCREEN; FILTER TUB, HANDLE and COVER; WASH DOWN HOSE, SUCTION LINE HOSE, and FILTER ASSEMBLY are clean and dry.
2. Assemble the Filter Tub by installing the components in the following sequence: 1) **FILTER ASSEMBLY**, 2) **SLUDGE CATCHER SCREEN, and PAN**, 3) **CRUMB CATCHER PAN**, 4) **COVER**, 5) **FILTER TUB HANDLE**, and 6) **SUCTION LINE HOSE**.

**CAUTION: WHEN ASSEMBLED, ENSURE THERE ARE NO FINGER LOOPS ON THE STANDPIPE SIDE OF THE MICRO-MESH FILTER.**

- a. **CAREFULLY** insert the Filter Assembly in the bottom of the Filter Tub with the **STANDPIPE** centered in the handle end of the tub.
- b. **CAREFULLY** insert the Sludge Catcher Screen and Pan, and the Crumb Catcher Pan in the Filter Tub.

**NOTE:** Failure to **PROPERLY** insert and seat these items in the Filter Tub may **DAMAGE** Fryer Components when the Filter Tub is placed in its Storage Location.

- c. Place the cover on the Filter Tub; then install the Handle on the Filter Tub.
- d. **SECURELY** connect the Suction Line Hose **FEMALE** Quick-Connect fitting to the **MALE** Quick-Connect plug on the filter screen **STANDPIPE**, **CAREFULLY** insert the Filter Tub Assembly beneath the fryer; then **SECURELY** connect the **MALE** Quick-Connect fitting on the Suction Line Hose to the **FEMALE** Bulkhead Coupling on the Fryer.

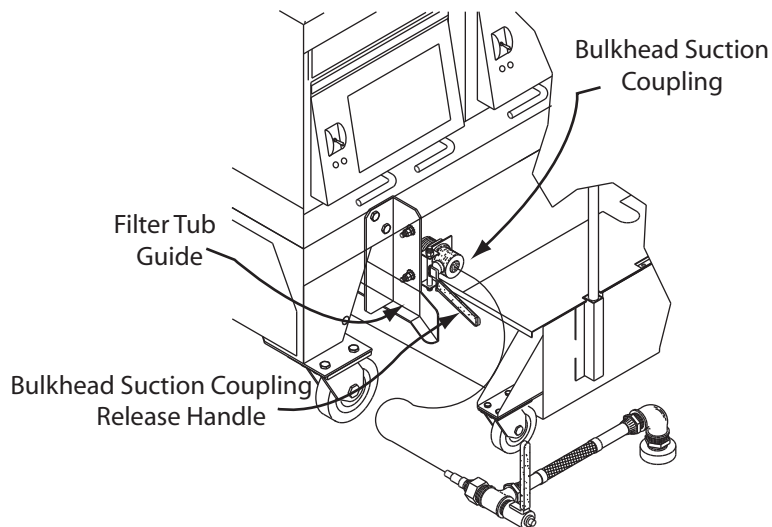

**ULTRASTAT 21 COOKING COMPUTER OPERATION** - The following are abbreviated operating procedures for a Model S & SC fryer equipped with an Ultrastat 21 Cooking Computer. The attached Ultrastat 21 Ultrafryer Computer Operation Instructions PN 30A009, contains **DETAILED** Operating, Filtering, Boil-Out and Programming Instructions.







**NOTE:** If the fryer is equipped with an Ultrastat 25 Cooking Computer proceed to page 25.

**A. START-UP and COOKING**

1. **ULTRASTAT 21 START-UP** - Safely start-up an Electric Fryer equipped with an Ultrastat 21 Cooking computer as follows:

<u>STEP</u>	<u>ACTION</u>	<u>RESPONSE</u>
1	ENSURE the drain valve lever on the fryer is in the <b>CLOSED</b> position, shortening is at the proper level, then turn the fryer <b>TOGGLE ON/OFF</b> switch to the <b>ON</b> position.	A. The <b>AMBER</b> Power lamp beside the <b>TOGGLE ON/OFF</b> switch will <b>LIGHT</b> .
<b>CAUTION: PRIOR TO PROCEEDING TO STEP 2 VISUALLY CHECK THAT THE HEAT MECHANISM IS COVERED WITH AT LEAST 2" (51 mm) OF SHORTENING.</b>		
2	Turn the Computer <b>ON</b> by depressing the computer <b>ON/OFF</b> button.	A. The <b>MELT</b> lamp will <b>LIGHT</b> to indicate the computer is in the <b>SHORTENING MELT MODE</b> . B. The <b>HEAT</b> lamp on the computer and the <b>RED</b> heat mechanism indicator lamp on the fryer will cycle <b>ON</b> and <b>OFF</b> indicating the heat mechanism is periodically being turned <b>ON</b> and <b>OFF</b> to gently heat the shortening.
3	Once the <b>MELT LIMIT TEMPERATURE</b> is reached, depress the <b>EXIT MELT BUTTON</b> on the computer to cancel the <b>SHORTENING MELT MODE</b> .	A. <b>LO</b> will appear in the computer display indicating shortening temperature is more than 10°F (5°C) below the set-point temperature. B. The <b>HEAT</b> lamp on the computer and the <b>RED</b> heat mechanism indicator lamp will remain <b>ON</b> until the set-point temperature is reached.
4	When <b>- - - -</b> appears in the Computer display indicating the <b>SET-POINT TEMPERATURE</b> of the shortening has been reached, a <b>COOK</b> cycle can be initiated.	

2. **COOKING** - When the Computer is taken out of the **SHORTENING MELT MODE** each morning, shortening in the fryer vat will be heated to its **SETPOINT** temperature and "**LO**" will appear in the display to indicate the shortening temperature is **MORE** than **10°F (5°C) BELOW** the setpoint temperature. When shortening temperature rises to the **SETPOINT** temperature **- - - -** will appear in the display indicating a **COOK CYCLE** can be started.

a. **STARTING A COOK CYCLE**- To start a cook cycle simply press the  product key for the product you wish to cook. If the product is programmed, the correct cooking time will be displayed  (example) and this time will immediately start to count down in minutes and seconds. If  is displayed immediately and the unit starts to signal, the key being operated is not programmed. If correctly programmed, it will count down to  followed by  and start to signal. To turn this signal **OFF** and reset the Computer, press the  product key used to start the **COOK CYCLE**.

b. **CANCELLING A COOK CYCLE** - If a cook cycle was inadvertently started it may be cancelled two (2) ways:

- 1) Press and hold the same product key  used to start the cook cycle for **4 SECONDS**. This prevents an accidental cancelling of a cook cycle while a product is being cooked.
- 2) A cook cycle can be **CANCELLED** at any time by turning the Ultrafryer Toggle ON/OFF Switch to the **OFF** position.

- B. **FILTERING SHORTENING** - Assemble the Filter Tub as described on page 18, **SECURELY** connect the **FEMALE** Quick-Connect fitting on the Suction Line Hose Assembly to the **MALE** Quick-Connect plug on the filter screen **STAND-PIPE**, insert the Filter Tub Assembly beneath the fryer; then **SECURELY** connect the **MALE** Quick-Connect plug on the on the Suction Line Hose to the **FEMALE** Bulkhead Coupling on the fryer as shown on the next page.

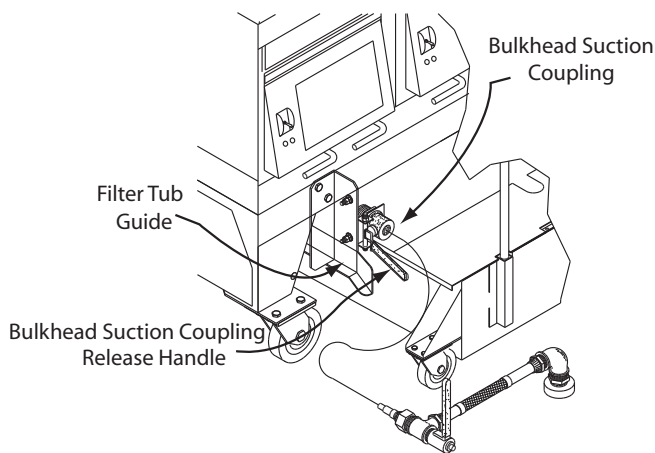

1. Turn the Toggle ON/OFF Switch on the fryer vat to be filtered **OFF**, place 16 ounces (.454 kg) by volume of **FILTER AGENT** in a 20" (508 mm) and 18" (457 mm) deep fryer vat; 14 ounces (.397 kg) in an 18" (457 mm) **SHALLOW** fryer vat; and 8 ounces (.227 kg) in a 14" (356 mm) fryer vat; thoroughly stir the filter agent into the shortening using the skimmer, then skim the shortening to remove any floating crumbs.

**CAUTION: PRIOR TO PROCEEDING TO THE NEXT STEP, PUT ON SAFETY GOGGLES, NEOPRENE INSULATED GLOVES AND AN APRON.**

2. Carefully open the drain valve on the vat to be filtered by turning the **DRAIN LEVER** slightly downward. When the bottom of the filter tub is covered with about 2" (51 mm) of shortening, **OPEN** the drain valve and slowly drain shortening to allow the heat mechanism to gradually **COOL**.
3. When all shortening in the vat has drained into the filter tub, use the **DRAIN ROD** to stand the wire grill on one side of the vat.
4. Use the drain rod to break up the sediment cake on the bottom of the vat.
5. Use a scraper to remove encrusted material from the sides of the vat and a scrubbing pad to remove carbon buildup from the top and sides of the heat mechanism. Use one (1) of the following procedures to **FLUSH** any remaining sediment or debris from the fryer vat:
  - a. Turn the **PUMP LEVER** to the **DOWN "ON"** position - The **RED** Pump Lamp will light and shortening in the filter tub will be pumped back into the vat through the **SWEEPER** nozzle in the bottom of the vat **FLUSHING** sediment and debris towards the vat drain. Use the drain rod or "L" shaped brush to pull the sediment on the bottom of the vat to and through the valve opening. When all sediment and debris has been flushed from the vat, turn the **PUMP LEVER** to the **UP "Off"** position, which will turn the **RED "Pump" Lamp OFF** and stop the shortening flow.
  - b. Connect the Wash Wand Nozzle to the Wash Wand Hose, **SECURELY** connect the male plug on this assembly to the Female fitting on the **TOPSIDE** Bulkhead connection; then place the **NOZZLE** in the vat and hold it firmly against an inner wall to prevent the hose from "jumping" when the pump is turned on. Turn the **RED** handle Spray Blaster/Wash Wand Activation Lever to the **DOWN "ON"** position. The **BLUE "Open"** lamp will light and shortening in the filter tub will be returned to the vat through the wash wand Hose and Nozzle which can be used to **FLUSH** sediment and debris from the vat walls, heat mechanism and bottom of the vat through the drain valve. **FLUSH** debris down the drain trough **PRIOR** to further cleaning of the fryer. When all sediment and debris has been flushed from the vat, turn the **RED** handle Spray Blaster/Wash Wand Activation Lever to the **UP "OFF"** position, which will turn the **BLUE "Open" Lamp OFF** and stop the shortening flow.
  - c. If applicable, hang the **SPRAY BLASTER** Assembly on the Fry Basket/Spray Blaster Holder where it is **CENTERED** in the vat. **SECURELY** connect the female coupler on the Wash Wand Hose to the male plug on the Spray Blaster and connect the male plug on the other end of the hose to the **TOPSIDE** Bulkhead connector. Turn the **RED** handle Spray Blaster/Wash Wand Activation Lever to the **DOWN "ON"** position. The **BLUE "OPEN"** lamp will light and shortening in the filter tub will be returned to the vat through the four (4) nozzles in the bottom of the spray blaster flushing sediment and debris through the drain valve. When all sediment and debris has been flushed from the vat, turn the **RED** handle Spray Blaster/Wash Wand Activation Lever to the **UP "OFF"** position, which will turn the **BLUE "OPEN" lamp OFF** and stop the shortening flow.

**CAUTION: DO NOT FLUSH SEDIMENT AND DEBRIS FROM THE FRYER VAT ANY LONGER THAN NECESSARY, BUT NO LONGER THAN 2 MINUTES.**

6. Ensure the Wash Wand Hose Assembly is separated from the **TOPSIDE** Bulkhead Connector, **NOZZLE ASSEMBLY / SPRAY BLASTER**; then hang the hose in an upright position so shortening can drain into a container. **THOROUGHLY** clean the Spray Blaster in the 3 compartment sink.
7. Replace the wire grill in the fryer vat; then check and **ENSURE** the Pump Levers on the other vats are in the **UP** “OFF” position and that the **RED** and **BLUE** lamps are **OFF**.
8. Turn the **DRAIN LEVER** to the **DOWN** “OPEN” position; then **POLISH** the shortening in the filter tub as follows:
  - a. Fryers **WITHOUT** an **AUTOMATIC VAT CLEANER** and a Computer **WITHOUT** a **SHORTENING MANAGEMENT SYSTEM**:

<b>STEP</b>	<b>ACTION</b>	<b>RESPONSE</b>
1	Set a timer for the amount of time established for <b>POLISHING</b> shortening; then turn the <b>PUMP LEVER</b> to the <b>DOWN</b> “ON” position.	<ol style="list-style-type: none"> <li>a. The <b>RED</b> “Pump” light will <b>LIGHT</b>.</li> <li>b. Shortening in the filter tub will begin circulating through the <b>SWEEPER NOZZLE</b> in the bottom of the vat.</li> </ol>

**CAUTION: DO NOT POLISH SHORTENING LONGER THAN THE TIME ESTABLISHED BY YOUR OPERATIONS DEPARTMENT.**

2	When <b>POLISHING</b> is complete; turn the <b>PUMP LEVER</b> and <b>DRAIN LEVER</b> to the <b>UP</b> position.	<ol style="list-style-type: none"> <li>a. The <b>RED</b> “Pump” light will turn <b>OFF</b>.</li> <li>b. Shortening Circulation will <b>STOP</b>.</li> </ol>
3	Turn the <b>PUMP LEVER</b> to the <b>DOWN</b> “ON” position to return shortening in the filter tub to the fryer vat.	<ol style="list-style-type: none"> <li>a. The <b>RED</b> “Pump” lamp will <b>LIGHT</b>.</li> <li>b. Shortening in the filter tub will be returned to the fryer vat through the <b>SWEEPER NOZZLE</b> in the bottom of the vat.</li> </ol>
4	When <b>ALL</b> shortening has been returned to the vat as indicated by <b>BUBBLING</b> of the shortening in the rear of the vat, turn the <b>PUMP LEVER</b> to the “OFF” <b>UP</b> position.	<ol style="list-style-type: none"> <li>a. The <b>RED</b> “PUMP” lamp will turn <b>OFF</b>.</li> <li>b. Bubbling action will stop.</li> </ol>
5	<b>CAREFULLY</b> remove the sediment from the Micro-Mesh screen with the filter tub scraper. <b>NOTE:</b> Magnepad Paper Filters <b>DO NOT</b> have to be scraped.	
6	If applicable, add shortening to the vat.	

- 1) Repeat steps 1 through 6 above to Polish shortening in the remaining fryer vats.
- 2) When all vats have been **FILTERED** and **POLISHED**, hang the Wash Down Hose in an upright position so shortening can drain into a container, and disconnect the **SUCTION LINE HOSE** from the **STAND-PIPE** and **BULKHEAD** connector shown below.

**NOTE:** Failure to hang the Wash Wand Hose in an upright position to drain may cause the hose to become clogged with hardened shortening.

- 3) **THOROUGHLY** clean the Filter Tub assembly and then place it in its storage location as described on page 30 in the Cleaning section of this manual.
- b. Fryers **WITH** an **AUTOMATIC VAT CLEANER** and a Computer **WITHOUT** a **SHORTENING MANAGEMENT SYSTEM**:
    - 1) Hang the Automatic Vat Clean (Spray Blaster) on the Fry Basket/Spray Blaster Holder where it is **CENTERED** in the vat, **SECURELY** connect the female coupler on the Wash Wand Hose to the Male plug on the Spray Blaster and connect the male plug on the other end of the hose to the **TOPSIDE** Bulkhead Coupler.
    - 2) Repeat procedures in paragraph B 1 through B 7 a 3) above.
    - 3) Disconnect and remove the Spray Blaster and Wash Wand Hose from the fryer, **THOROUGHLY** clean the Spray Blaster and hang the Wash Down Hose in an upright position to allow shortening to drain into a container.
  - c. Fryers with **AUTOMATIC VAT CLEANER** and a Computer **WITH** the **SHORTENING MANAGEMENT SYSTEM**:

- 1) Install and connect the Spray Blaster to the fryer as described in paragraph 5 c on page 20.
- 2) Filter and polish the shortening in each fryer vat following the procedures contained in the “Shortening Management Training Guide: and the Ultrastat 21 Ultrafryer Computer Operation Instructions provided with each fryer.
- 3) Disconnect and remove the Spray Blaster and Wash Wand Hose as described in paragraph 6 on page 21.

C. **SHORTENING DISPOSAL/FRYER BOIL-OUT** - the instructions listed below “complement” procedures contained in the applicable Operating Instruction Manual which should be used along with this manual when **BOILING OUT** a fryer.

1. **SHORTENING REMOVAL / DISPOSAL** - Fryer vats should be **BOILED-OUT** at least every **7 DAYS** to remove carbon build up and other encrusted materials. Fryers with an Ultrastat 21 Cooking Computer with the **SHORTENING MANAGEMENT SYSTEM** should be **BOILED-OUT** when **diSP** appears in the computer display.

a. If the store is equipped with a Shortening Disposal System, remove used shortening from the fryer vat that is **CLOSEST** to the Shortening Disposal System connector. If the store is **NOT** equipped with a Shortening Disposal System, remove used shortening from the first fryer vat.

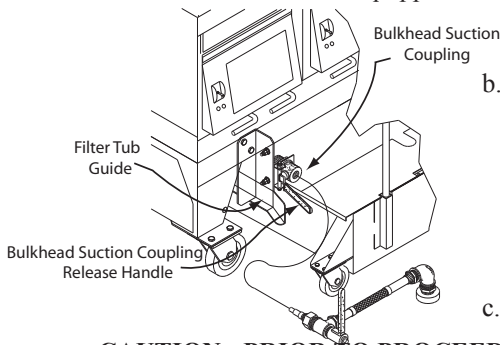

b. Assemble the filter Tub as described on page 18, position the filter tub on the **FILTER TUB GUIDES** beneath the **LEFT** side of the fryer; then **SECURELY** connect the Suction Line Hose **FEMALE** Quick-Connect fitting to the **MALE** Quick-Connect plug on the Filter Screen **STANDPIPE**, **CAREFULLY** insert the filter tub assembly beneath the fryer; then **SECURELY** connect the **MALE** Quick Connect plug on the Suction Line Hose to the **FEMALE** Bulkhead Coupling on the fryer as shown to the left.

c. Turn the **TOGGLE ON/OFF SWITCH** to the first vat **OFF**.

**CAUTION: PRIOR TO PROCEEDING TO THE NEXT STEP, PUT ON SAFETY GOGLES, NEOPRENE INSULATED GLOVES AND AN APRON.**

d. Turn the venthood Exhaust Fan **ON** and drain shortening from **EACH** fryer vat as follows:

- 1) Carefully open the drain valve by turning the **DRAIN LEVER** slightly downward. When the bottom of the filter tub is covered with about 2” (51 mm) of shortening, **OPEN** the drain valve and slowly drain shortening to allow the heat mechanism to gradually **COOL**.
- 2) When all shortening has drained into the filter tub, use the **DRAIN ROD** to stand the wire grill on one side of the vat.
- 3) Use a scraper to remove encrusted material from the sides of the vat and a scrubbing pad to remove carbon buildup from the top and sides of the heat mechanism. Use one of the following procedures to **FLUSH** any remaining sediment or debris from the fryer vat.
  - a) Turn the **PUMP LEVER** to the **DOWN “ON”** position - The **RED** Pump Lamp will light and shortening in the filter tub will be pumped back into the vat through the **SWEEPER** nozzle in the bottom of the vat **FLUSHING** the sediment and debris towards the vat drain. Use the drain rod or “**L**” shape brush to pull the sediment on the bottom of the vat to and through valve opening. When all sediment and debris has been flushed from the vat, turn the **PUMP LEVER** to the **UP “OFF”** position, which will turn the **RED** pump lamp **OFF** and stop the shortening flow.
  - b) Connect the Wash Wand nozzle to the Wash Wand Hose, **SECURELY** connect the male plug on the hose to the female **TOPSIDE** Bulkhead Connector; then place the **NOZZLE** in the vat and hold it firmly against an inner wall to prevent the hose from “jumping” when the pump is turned **ON**. Turn the **RED** handle Spray Blaster/Wash Wand Activation Lever to the **DOWN “ON”** position. The **BLUE “OPEN”** lamp will light and shortening in the filter tub will be returned through the Wash Wand Hose and Nozzle which can be used to **FLUSH** sediment and debris from the vat walls, heat mechanism and bottom of the vat through the drain valve. When all sediment and debris has been flushed from the vat, turn the **RED** handle Spray Blaster/Wash Wand Activation Lever to the **UP “OFF”** position which will turn the **BLUE “OPEN”** lamp **OFF**, and stop the shortening flow.
  - c) If applicable, hang the **SPRAY BLASTER** Assembly on the Fry Basket/Spray Blaster Holder where it is **CENTERED** in the vat. **SECURELY** connect the female coupler on the Wash Wand Hose to the male plug on the Spray Blaster and connect the male plug on the other end of the hose to the female **TOPSIDE** Bulkhead connector. Turn the **RED** handle Spray Blaster/Wash Wand Activation Lever to the **DOWN “ON”** position. The **BLUE “OPEN”** lamp will light and shortening in the filter tub will be returned to the vat through the four (4) nozzles in the bottom of the spray blaster flushing sediment and debris through the drain valve. When all sediment and debris has been flushed from the vat, turn the **RED** handle Spray Blaster/Wash Wand Activation Lever to the **UP “OFF”** position, which will turn the **BLUE “OPEN”** lamp **OFF** and stop the shortening flow.
- 4) When shortening has completely drained from the vat, turn the **PUMP LEVER** and **DRAIN LEVER** to the **(UP)** position.

**NOTE:** Ensure the Wash Wand Hose Assembly is separated from the **TOPSIDE** Bulkhead Connector, **NOZZLE ASSEMBLY/SPRAY BLASTER**; then hang the hose in an upright position so shortening can drain into a container; then **THOROUGHLY** clean the Spray Blaster in the 3 compartment sink.

- 5) Dispose of used shortening as follows:
  - a) Restaurants **NOT** equipped with a Shortening Disposal System:
    - (1) Place the Wash Down Hose nozzle into a **METAL** container and hold it firmly against an inner wall. This prevents the hose from “jumping” when the Filter Pump is turned on.
    - (2) Turn the **RED** Handle Spray Blaster/Wash Wand Activation Lever to the “ON” (**DOWN**) position and pump shortening from the filter tub into the metal container.
    - (3) When all shortening in the filter tub has been pumped into the metal container, turn the **RED** Handle Spray Blaster/Wash Wand Activation Lever to the “OFF” (**UP**) position and remove any sediment from the Micro-Mesh filter screen using the filter tub scraper.

**NOTE:** Magnepad Paper Filter Assemblies **DO NOT** have to be **SCRAPED**.

- (4) Repeat steps d 1), d 2), d 3), d 4), d 5) a) (1) - (3) above to remove shortening from remaining vats to metal containers.
- b) Restaurants **EQUIPPED** with a Shortening Disposal System:
  - (1) Remove the Wash Down Hose from the **TOPSIDE** BULKHEAD connector; then connect the **MALE** plug on the Shortening Disposal Hose to this connector.
  - (2) **SECURELY** connect the fitting on the other end of the Shortening Disposal Hose to the Disposal System connector on the wall.
  - (3) Turn the **RED** Handle Spray Blaster/Wash Wand Activation Lever to the “ON” (**DOWN**) position and pump shortening from the filter tub into the exterior rendering tank.
  - (4) When all shortening has been suctioned from the filter tub, turn the **RED** Handle Spray Blaster/Wash Wand Activation Lever LEVER to the “OFF” (**UP**) position, and remove any sediment from the Micro-Mesh filter screen using the Filter Tub Scraper.

**NOTE:** Magnepad Paper Filter Assemblies **DO NOT** have to be **SCRAPED**. Leave the Shortening Disposal Hose connected to the vat stem and the Disposal Stem connector.

- (5) Repeat steps d1) through d5) and b) (1) through (4) above to transfer shortening from remaining vats to the exterior rendering tank.
- (6) Remove the Shortening Disposal Hose from **TOPSIDE** BULKHEAD connector and replace the the wire grill in each vat.
- (7) **IMMEDIATELY** hang the Wash Down Hose and, if applicable the Shortening Disposal Hose in an upright position and **THOROUGHLY** clean and reassemble the filter tub.

**NOTE:** “**diSP**” will disappear in the Ultrastat 21 Cooking Computer display with the **SHORTENING MANAGEMENT SYSTEM** after the shortening has been disposed.

## 2. FRYER BOIL-OUT

- a. **BOIL-OUT** each fryer following cleaning instructions contained in the Cleaning Manual provided by your approved chemical supplier. The following are generic procedures:
  - 1) Ensure all Drain Levers are in the closed (**UP**) position, then add water to each vat until it reaches a point two **2” (51 mm) BELOW** the middle line of the “**E ←**” in the word **LEVEL** of the **UPPER** shortening level mark on the rear wall of the vats.
  - 2) Add the amount of **BOIL-OUT COMPOUND** in each fryer vat as prescribed in the Cleaning Manual provided by the Chemical Supplier.
  - 3) Turn the Toggle ON/OFF switch and, if applicable, Manual Gas valve for each fryer vat to the **ON** position; then depress the Computer ON/OFF key to the **ON** position.

**NOTE:** The drain lever must be in the closed **UP** position to turn the computer **ON**.

- 4) Place the Computer in the **BOIL MODE** by pressing the following Computer keys in the order shown:

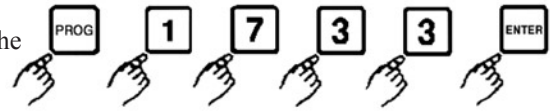

**NOTE:** **boil** will appear in the Computer display and the Computer will turn the Ultrafryer heat mechanism ON and OFF to heat and maintain the boil-out solution to **190°F (88°C)**.

- 5) When the boil-out solution reaches **190°F (88°C)** set a timer for 30 minutes. Frequently scrub the sides, front and rear of each fryer vat with a long handled scrub brush.
- 6) After the boil-out solution has '**BOILED**' for 30 minutes and the timer sounds press the following computer keys in the order shown to **EXIT BOIL MODE**:

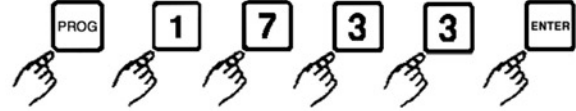

- 7) Turn the Toggle ON/OFF Switch and, if applicable, the Manual Gas Valve for each fryer to their OFF position and **CAREFULLY** dispose of the boil-out solution in each fryer into a floor drain.

**NOTE:** Do not use the filter pump to remove water from the vats as this will cause premature pump failure and void the pump warranty.

- 8) Use a scrubbing pad to remove carbon buildup from the top of the heat mechanism. To remove carbon buildup on the sides and bottom of the heat mechanism; slide one end of a stropping pad under each section, grasp that end with a pair of tongs, and rock the pad up and down along the length of each section until all encrusted material has been removed.
- 9) Rinse each fryer with hot water until the water coming out of the drain valve is **clear**.
- 10) Mix a solution of **ONE PART** vinegar to **25 PARTS** of water. Place this mixture into a one gallon garden pressure sprayer; and **THOROUGHLY** spray this solution onto the **SIDES, HEAT MECHANISM, and BOTTOM** of each fryer to neutralize the Boil-Out Compound.

**NOTE:** Boil-Out Compound will cause shortening to break down rapidly if it is not neutralized.

- 11) **THOROUGHLY** wipe the sides, heat mechanism, and bottom of each fryer with clean, lint-free, dry towels to remove any remaining water; then fill each fryer with **NEW** shortening following procedures on page 5 of this manual.

**ULTRASTAT 25 COOKING COMPUTER OPERATION** - The following are abbreviated operating procedures for a Model S & SC fryer equipped with an Ultrastat 25 Cooking Computer. The attached Ultrastat 25 Ultrafryer Computer Operation Instructions PN 30A051, contains **DETAILED** Operating, Filtering, Boil-Out and Programming Instructions.

**A. START-UP and COOKING**

1. **ULTRASTAT 25 START-UP** - Safely start-up an Electric Fryer equipped with an Ultrastat 25 Cooking computer as follows:

<u>STEP</u>	<u>ACTION</u>	<u>RESPONSE</u>
1	ENSURE the drain lever on the fryer is in the <b>CLOSED</b> position, shortening is at the proper level, then turn the fryer <b>TOGGLE ON/OFF</b> switch to the <b>ON</b> position.	A. The <b>AMBER</b> Power lamp beside the <b>TOGGLE ON/OFF</b> switch will <b>LIGHT</b> .
2	Turn the Computer <b>ON</b> by depressing the computer <b>ON/OFF</b> key.	A. <b>MELT E, G, or P</b> , will appear in the computer Display to indicate the computer is in the <b>SHORTENING MELT MODE</b> . B. The <b>HEAT DEMAND</b> lamps on the computer and the <b>RED INDICATOR</b> lamp on the fryer will cycle <b>ON</b> and <b>OFF</b> indicating the heat mechanism is periodically being turned <b>ON</b> and <b>OFF</b> to gently heat the shortening.
3	When the <b>MELT RELEASE TEMPERATURE</b> is reached, the Melt Mode may be canceled by pushing the <b>OK/EXIT</b> key.	A. <b>LOW</b> will appear in the computer display indicating shortening temperature is more than the <b>READY BAND</b> below the (SETPOINT) temperature B. The <b>HEAT DEMAND</b> lamps on the computer and the <b>RED INDICATOR</b> lamp on the fryer will cycle <b>ON</b> and <b>OFF</b> indicating the heat mechanism is being periodically turned <b>ON</b> and <b>OFF</b> to gently heat the shortening.
4	When <b>READY</b> appears in the computer display indicating the shortening temperature is no more than the <b>READY BAND</b> below (SETPOINT) and is no higher than 40°F (22°C) above the (SETPOINT) temperature, a <b>COOK</b> cycle can be initiated.  <b>NOTE:</b> The <b>READY BAND</b> is factory set according to the customer’s order, usually set at 10°F (5°C).	

**2. COOKING**

When the Computer is taken out of the **SHORTENING MELT MODE** each morning, shortening in the fryer vat will be heated to its **SETPOINT** temperature and “**LOW**” will appear in the display to indicate the shortening temperature is **MORE** than the **READY BAND** temperature **BELOW** the setpoint temperature. When shortening temperature rises to the **SETPOINT** temperature **READY** will appear in the display indicating a **COOK CYCLE** can be started.

**a. STARTING A COOK CYCLE**

To start a cook cycle, simply press the Product Key LED will be displayed, (example, **14:00**) and this time will immediately start to count down in minutes and seconds. If correctly programmed, the computer will count down to **00:00**, the alarm will **SOUND** and **DONE 1** will appear in the display. Press Product Key 1 to silence the alarm and reset that product key for another cook cycle.



the product key you wish to cook. If the product key is programmed, the Product Key **LED** will **BLINK FAST** and **CK 1** and correct cooking time will be displayed.

**b. CANCELLING A COOK CYCLE**

If a cook cycle was inadvertently started

- 1) Press and hold the same product key used to start the cook cycle for **4 SECONDS**. This prevents an accidental cancelling of a cook cycle while a product is being cooked.
- 2) A cook cycle can be **CANCELLED** at any time by turning the Ultrafryer Toggle ON/OFF SWITCH to the **OFF** position.





it may be cancelled two (2) ways:

- B. FILTERING SHORTENING** - In many restaurant situations shortening in the Ultrafryer should be filtered at least twice a day, once after the lunch rush and again after the dinner rush. Other users may establish filter frequencies in line with their oil cleaning requirements and programmed filter prompts. The fryer vat used to cook French Fries should be filtered **FIRST**, followed by fryer vats for other products. The instructions listed below “complements” step-by-step procedures contained in the applicable Ultrafryer Fryer Operations Manual which should be used along with this manual when **FILTERING SHORTENING**.

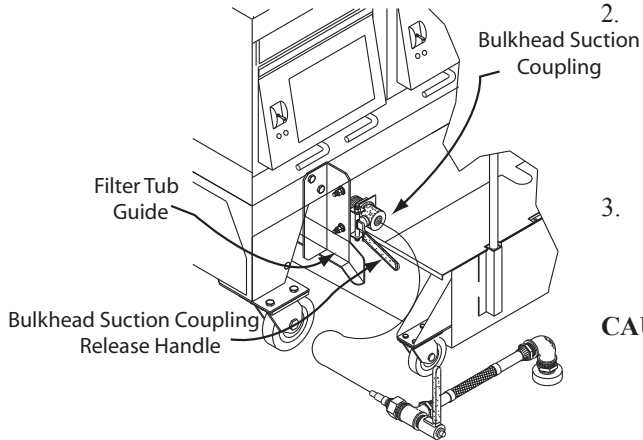
1. Assemble the Filter Tub as described on page 18, **SECURELY** connect the Suction Line Hose **FEMALE** Quick-Connect fitting to the **MALE** Quick-Connect plug on the filter screen **STANDPIPE**, **CAREFULLY** insert the Filter Tub Assembly beneath the fryer; then **SECURELY** connect the **MALE** Quick-Connect fitting on the Suction Line Hose to the **FEMALE** Bulkhead Coupling shown below:



2. When the **FILTER PROMPT FEATURE** has been activated and **FILTER** appears in the display, alternating with a normal display: 1) press the  key to display the current **HITS**, 2) press the  key again to display the current **TIME PROMPT** time and 3) plan to filter shortening at the next convenient time.

3. When it is convenient to filter shortening, filter each fryer as follows:
  - a. Turn the **TOGGLE ON/OFF SWITCH** for the vat to be filtered **OFF**.

**CAUTION: DO NOT TURN THE COMPUTER OFF!!**

- b. Place **16 OUNCES (.45 kg)**, by volume, of **FILTER AGENT** in a 20" (508 mm) and 18" (457 mm) deep fryer vat, 14 ounces (.39 kg) in an 18" (457 mm) shallow fryer vat and 8 ounces (.23 kg) in a

14" (356 mm) fryer vat; thoroughly stir the filter agent into the shortening using the skimmer, then skim the shortening to remove any floating crumbs.

**CAUTION: PRIOR TO PROCEEDING TO THE NEXT STEP, PUT ON SAFETY GOGGLES, NEOPRENE INSULATED GLOVES AND AN APRON.**

- c. Carefully open the drain valve on the vat to be filtered and polished by turning the **DRAIN LEVER** slightly downward, **DRAINING** alternating with **FILTER** will appear in the Computer display. When the bottom of the filter tub is covered with about two (2) inches (51 mm) of shortening, **OPEN** the drain lever and slowly drain shortening to allow the heat mechanism to gradually **COOL**.
- d. When all shortening in the vat has drained into the filter tub, use the **DRAIN ROD** to stand the wire grill on one side of the vat.
- e. Use the drain rod and/or the "L" shaped brush to pull the sediment on the bottom of the vat towards the valve opening, then use the rod to push sediment through the valve opening.
- f. **SECURELY** connect the **MALE** In-Line Plug on the Wash Down Handle & Nozzle to the **FEMALE** Locking Seal Coupling on the Wash Down Hose then **SECURELY** connect the **MALE** IN-LINE Plug on the other end of the Wash Down Hose to the **TOPSIDE** Bulkhead Coupling on the upper rear panel of the fryer. A distinct **CLICK** will be heard when the Male Plug is properly seated in the Female Coupling.
- g. Use a scraper to remove encrusted material from the sides of the vat and a scrubbing pad to remove carbon build-up from the top and sides of the heat mechanism. Use one (1) of the following procedures to **FLUSH** any remaining sediment or debris from the fryer vat:
  - 1) Turn the **PUMP LEVER** to the **DOWN "ON"** position. The **RED "Pump"** Lamp will light and shortening in the filter tub will be pumped back into the vat through the **SWEEPER** nozzle in the bottom of the vat **FLUSHING** sediment and debris towards the vat drain. Use the drain rod or "L" shaped brush to pull the sediment on the bottom of the vat to and through the valve opening. When all sediment has been flushed from the vat, turn the **PUMP LEVER** to the **UP "OFF"** position, which will stop the shortening flow and turn the **RED "Pump"** Lamp **OFF**.
  - 2) Connect the Wash Wand Nozzle to the Wash Wand Hose, **SECURELY** connect this assembly to the **TOPSIDE BULKHEAD** connector; then place the **NOZZLE** in the vat and hold it firmly against an inner wall to prevent the hose from "jumping" when the pump is turned on. Turn the **RED** handle Spray Blaster/Wash Wand Activation Lever to the **DOWN "ON"** position. The **BLUE "OPEN"** lamp will light and shortening in the filter tub will be returned to the vat through the wash wand hose and nozzle which can be used to **FLUSH** sediment and debris from the vat walls, heat mechanism and bottom of the vat through the drain valve. When all sediment and debris has been flushed from the vat, turn the **RED** handle Spray Blaster/Wash Wand Activation Lever to the **UP "OFF"** position which will stop the shortening flow from the nozzle and turn the **BLUE "OPEN"** lamp **OFF**.

- 3) If applicable, hang the **SPRAY BLASTER** assembly on the Fry Basket/Spray Blaster Holder where it is **CENTERED** in the vat. **SECURELY** connect the male plug on the Wash Wand Hose to the female coupler on the Spray Blaster and connect the male plug on the other end of the hose to the **TOPSIDE BULKHEAD** connector. Turn the **RED** handle Spray Blaster/Wash Wand Activation Lever to the **DOWN “ON”** position. The **BLUE “OPEN”** lamp will light and shortening in the filter tub will be returned to the vat through the four (4) nozzles in the bottom of the spray blaster flushing sediment and debris through the drain valve. When all sediment and debris has been flushed from the vat, turn the **RED** handle Spray Blaster/Wash Wand Activation Lever to the **UP “OFF”** position, which will stop shortening flow from the blaster nozzles and turn the **BLUE “OPEN”** lamp **OFF**.

**CAUTION: DO NOT FLUSH SEDIMENT AND DEBRIS FROM THE FRYER VAT ANY LONGER THAN NECESSARY, BUT NO LONGER THAN 2 MINUTES.**

- h. Replace the wire grill in the fryer, ensure the Pump Levers on other vats are in the **UP “OFF”** position and that the **RED** and **BLUE** lamps are **OFF**.

**NOTE:** Ensure the wash wand hose assembly is separated from the **NOZZLE ASSEMBLY/SPRAY BLASTER** and **TOPSIDE** Bulkhead connector; then hang it in an upright position so shortening in the hose can drain into a metal container.

- i. **POLISH** the shortening in the filter tub as follows:
  - 1) Fryers **WITHOUT** a **DIGITAL TIMER** or an **AUTOMATIC VAT CLEANER**:
    - a) Turn the **Pump Lever** to the “ON” (**DOWN**) position to allow shortening in the filter tub to circulate through the system; then, press the **TIME** key on the Computer to activate the Filter Timer. **FILT 10:00** will appear in the display and immediately start counting down.

**CAUTION: DO NOT POLISH THE SHORTENING LONGER THAN TEN (10) MINUTES AS IT WILL PUMP EXCESS AIR INTO THE SHORTENING CAUSING SHORTENING TO BREAK DOWN.**

**NOTE:** The filter pump system can **ONLY** be operated when the fryer’s Toggle ON/OFF switch is in the **OFF** position and the **PUMP LEVER** is in the “ON” (**DOWN**) position.

- b) When the Filter Timer counts down to **00:00**, **FILTER** alternating with **DONE** will appear in the display and an alarm will sound for about 5 seconds.
- c) The Filter Timer can be terminated early or **TIMEOUT/ALARM** acknowledged, by pressing the **OK/EXIT** key. The display will then be **DRAIN** alternating with **CLOSE**.
- d) Turn the **PUMP LEVER** and **DRAIN LEVER** to the (UP) position. The Filter Hit Count and Time Prompt will reset and the display will show **TURN OFF**. In addition, closing the Drain Valve will also terminate the **FILTER DONE** display.
- e) Turn the **Pump Lever** to the “ON” (**DOWN**) position to automatically return the shortening in the filter tub to the Fryer.
- f) When all shortening has been returned to the vat, turn the Pump Lever to the “OFF” (**UP**) position, then **CAREFULLY** remove any sediment from the filter screen using the Filter Tub Scraper.

**NOTE:** Magnepad Paper Filter Assemblies **DO NOT** have to be **SCRAPED** after filtering shortening.

**NOTE:** The **RED** Pump Lamp will **LIGHT** whenever the **PUMP LEVER** is “ON” “DOWN” and will turn **OFF** when the lever is in the **UP “OFF”** position.

- g) If applicable, add shortening to the fryer vat; then press the  key, **OFF**, then back **ON** again to resume normal operation. **MELT G/E/P** will appear in the display.
- h) Repeat step 3 i 1) a) through 3 i 1) g) to filter shortening in the remaining vats.
- i) When all vats have been filtered, separate the Wash Down Hose Nozzle from the hose and **IMMEDIATELY** hang the hose in an upright position so shortening can drain into a container. Remove the the Suction Line Hose Assembly from the **BULKHEAD** Suction Coupling beneath the left end of the fryer by depressing the **BUTTON** release lever; then remove the filter tub from beneath the fryer.
- j) Remove the Filter Tub from beneath the fryer, **THOROUGHLY** clean the filter tub assembly according to procedures in the Cleaning Section; then re-assemble the filter tub and place it in its storage location.
- 2) Fryers **WITH** a **DIGITAL SC TIMER** and an **AUTOMATIC VAT CLEANER**:
  - a) Hang the “Automatic Vat Cleaner” (Spray Blaster) on the Fry Basket/Spray Blaster Holder where it is **CENTERED** in the vat, **SECURELY** connect the female coupler on the Wash Wand Hose to the male plug on the Spray Blaster and connect the male plug on the other end of the hose to the **TOPSIDE** Bulkhead Connector.

- b) Ensure the Drain Lever for the vat to be filtered is in the **DOWN** “OPEN” position then perform the following steps to polish the shortening:

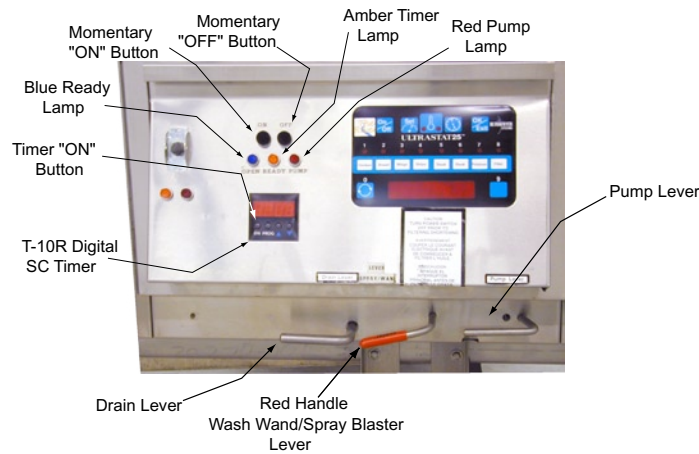

<u>STEP</u>	<u>ACTION</u>	<u>RESPONSE</u>
1	Turn the <b>RED</b> Handle Spray Blaster/Wash Wand Activation Lever to the <b>DOWN</b> “ON” position.	a. The <b>BLUE</b> “READY” lamp will <b>LIGHT</b> .
2	Depress then release the “Momentary” <b>ON</b> button.	a. Electrical power will be applied to the SC Digital Timer circuitry. b. The <b>AMBER</b> “TIMER” lamp will <b>LIGHT</b> .
3	Depress the <b>ON</b> button on the SC Digital Timer.	a. The <b>RED</b> “PUMP” lamp will <b>LIGHT</b> . b. The pre-set <b>POLISH</b> time will appear on the timer display and immediately start counting down. c. Shortening in the Filter tub will begin circulating through the Wash Down Hose or Spray Blaster and the vat to <b>POLISH</b> the shortening.
4	When the “pre-set” <b>POLISH</b> time counts down to <b>00:00</b> , an ALARM will sound.	a. Depress the <b>OFF</b> button on the SC Digital Timer, which will turn the <b>RED</b> “PUMP” lamp <b>OFF</b> . b. Depress then release the “Momentary” <b>OFF</b> button which will turn the <b>AMBER</b> “TIMER” lamp <b>OFF</b> . c. Turn the <b>RED</b> Handle Wash Wand Lever to the <b>UP</b> “OFF” position which will turn the <b>BLUE</b> “READY” lamp <b>OFF</b> .
5	Turn the Drain Lever to the <b>CLOSED</b> “UP” position; then turn the Pump Lever to the <b>DOWN</b> “ON” position.	a. The <b>RED</b> “PUMP” lamp will turn <b>ON</b> . b. Shortening in the filter tub will be returned to the vat through the <b>SWEEPER NOZZLE</b> on the bottom of the vat.
6	When <b>ALL</b> shortening has been returned to the vat as indicated by the bubbling at the rear of the vat, turn the Pump Lever to the <b>UP</b> “OFF” position.	a. The <b>RED</b> “PUMP” lamp will turn <b>OFF</b> . b. Bubbling at the rear of the vat will stop.
7	If applicable, add shortening to the vat, then press the  key <b>OFF</b> , then back <b>ON</b> again to resume normal operation for that vat.	

- c) Remove sediment and debris from the micro-mesh filter screen using the scraper.

**NOTE:** Magnepad Paper Filter Assemblies don not have to be scraped.

- d) Repeat procedures in paragraphs 3 i 2) a) through 3 i 2) c) including steps 1-7 above to polish shortening in the other vats.
- e) When the shortening in **ALL** vats have been polished; remove, clean and place the Spray Blaster in its storage location; then hang the Wash Wand Hose in an upright position so shortening can drain into a container.
- f) Remove the filter tub from beneath the fryer, **THOROUGHLY** clean the filter tub assembly according to procedures on page 30 in the Cleaning Section; then reassemble the filter tub and place it in its storage location.

### C. SHORTENING DISPOSAL/FRYER BOIL-OUT

The instructions listed below “complement” step-by-step procedures contained in the applicable Ultra Fryer Maintenance and Repair Manual which should be used along with this manual when **BOILING OUT** a fryer.

1. **SHORTENING REMOVAL/DISPOSAL** - If the Computer has been programmed for the **DISPOSAL PROMPT FEATURE**, **DISPOSE** alternating with a “NORMAL” display will appear in the Computer Display when the Disposal Hit Count Limit (**DHL #####**) is reached. Cooking Operations may continue until it is convenient to dispose of shortening. When it is convenient to dispose of shortening proceed as follows:

- a. If the store is equipped with a Shortening Disposal System, remove used shortening from the fryer vat that is **CLOSEST** to the Shortening Disposal System connector. If the store is **NOT** equipped with a Shortening Disposal System, remove used shortening from the first fryer vat.
- b. Assemble the Filter Tub as described on page 18, position the filter tub on the **FILTER TUB GUIDES** beneath the **LEFT** side of the fryer, **SECURELY** connect the Suction Line Hose **FEMALE** Quick-Connect fitting to the **MALE** Quick-Connect Plug on the filter screen **STANDPIPE**, **CAREFULLY** insert the Filter Tub Assembly beneath the fryer until it is butted against the **FILTER TUB STOP**; then **SECURELY** connect the **MALE** Quick-Connect Plug on the Suction Line Hose to the **FEMALE** Bulkhead Coupling on the fryer as shown in the diagram:
- c. Turn the **TOGGLE ON/OFF SWITCH** to the first vat **OFF**.

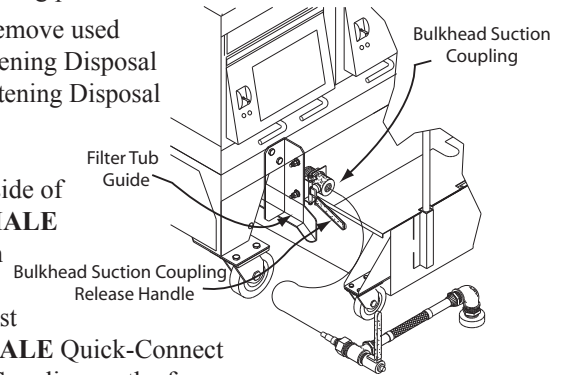

**CAUTION: PRIOR TO PROCEEDING TO THE NEXT STEP, PUT ON SAFETY GOGGLES, NEOPRENE INSULATED GLOVES AND AN APRON.**

- d. Turn the venthood Exhaust Fan **ON** and drain shortening from **EACH** fryer vat as follows:
  - 1) Carefully open the drain valve by turning the **DRAIN LEVER** slightly downward. When the bottom of the filter tub is covered with about 2” (51 mm) of shortening, **OPEN** the drain lever and slowly drain shortening to allow the heat mechanism to gradually **COOL**.

**NOTE:** When the drain valve is opened, **DISPOSE** alternating with **DRAINING** will appear in the display.

- 2) When all shortening has drained into the filter tub, use the **DRAIN ROD** to stand the wire grill on one side of the vat.
- 3) **SECURELY** connect the **MALE** In-Line Plug on the Wash Down Handle and Nozzle to the **FEMALE** Locking Seal Coupling on the Wash Down Hose; then **SECURELY** connect the **MALE** In-Line Plug on the other end of the Wash Down Hose to the female **TOPSIDE** Bulkhead Coupling on the upper rear panel of the Fryer. A distinct **CLICK** will be heard when Male Plugs are properly seated in the female couplings.

**CAUTION: IF THE PLUGS ARE NOT SECURELY ATTACHED TO THE COUPLERS, HOT SHORTENING WILL BE DISCHARGED AROUND THESE CONNECTIONS WHICH COULD CAUSE SEVERE BURNS.**

- 4) Place the Wash Down Hose Nozzle into the vat and hold it firmly against the inner wall. This prevents the hose from “jumping” when the Filter Pump is turned on.
- 5) Turn the **RED** handle Spray Blaster/Wash Wand Activation Lever to the **DOWN “ON”** position. The **BLUE** “OPEN” lamp will light and shortening in the filter tub will be returned to the vat through the Wash Wand Nozzle. Hold the nozzle at a 45° angle from the bottom of the vat causing the shortening sediment and debris to bounce off the rear wall of the fryer and flow toward the drain valve.
- 6) Use the drain rod to push the sediment through the drain valve to keep the drain clear. Hose off the Heat Mechanism and all walls of the fryer vat until all the shortening and residue on the bottom of the vat has been flushed through the drain into the filter tub.
- 7) When all sediment and debris has been flushed from the vat; turn the **RED** handle Spray Blaster/Wash Wand Activation Lever to the **UP “OFF”** position which will stop shortening flow from the nozzle and turn the **BLUE** “OPEN” lamp **OFF**.
- 8) Turn the **DRAIN LEVER** to the closed **UP** position and dispose of the used shortening as follows:
  - a) Restaurants **NOT** equipped with a Shortening Disposal System:
    - (1) Place the Wash Down Hose nozzle into a **METAL** container and hold it firmly against an inner wall. This prevents the hose from “**JUMPING**” when the Filter Pump is turned **ON**.

- (2) Turn the Wash Wand Lever to the “ON” **DOWN** position and pump the used shortening in the filter tub into the metal container.
- (3) When all shortening in the filter tub has been pumped into the metal container, turn the **RED HANDLE** Spray Blaster/Wash Wand Activation Lever to the “OFF” (**UP**) position and remove any sediment from the micro-mesh filter screen using the filter tub scraper.

**NOTE:** Magnepad Paper Filter Assemblies **DO NOT** have to be **SCRAPED**.

- (4) Repeat steps **d1), d2), d3), d4), d5), d6), d7), d8) a) (1) through (3)** above to remove shortening from remaining vats to metal containers.
- b) Restaurants **EQUIPPED** with a Shortening Disposal System:
  - (1) Remove the Wash Down Hose **MALE** In-Line Plug from the female **TOPSIDE** Bulkhead Coupling on the upper panel of the Fryer by depressing the **BUTTON RELEASE** lever; then **SECURELY** connect the Shortening Disposal Hose **MALE** In-Line Plug to this female **TOPSIDE** Bulkhead Coupling.
  - (2) **SECURELY** connect the fitting on the other end of the Shortening Disposal Hose to the Disposal System connector on the wall and **ENSURE ALL** valves (pertinent to the flow of shortening) to the Rendering tank are **OPEN**.
  - (3) Turn the **RED HANDLE** Spray Blaster/Wash Wand Activation Lever to the “ON” (**DOWN**) position and pump shortening from the filter tub into the exterior rendering tank.
  - (4) When all shortening has been suctioned from the filter tub, turn the **RED HANDLE** Spray Blaster/Wash Wand Activation Lever to the “OFF” (**UP**) position, and if applicable, remove any sediment from the Micro-Mesh filter screen using the Filter Tub Scraper.  
**THE MAGNEPAD FILTER DOES NOT HAVE TO BE SCRAPPED.**

**NOTE:** Leave the Shortening Disposal Hose connected to Bulkhead Coupling and Disposal System connector.

- (5) Repeat steps **d1), d2), d3), d4), d5), d6), d7)** and **d8) b) (1) through (4)** to remove shortening from remaining vats to exterior rendering tank.
- 9) Remove the Shortening Disposal Hose/Wash Down Hose from the female **TOPSIDE** Bulkhead Coupling on the rear wall of the fryer and replace the wire grill in each vat.
- (10) **IMMEDIATELY** hang the Wash Down Hose and, if applicable the Shortening Disposal Hose in an upright position and **THOROUGHLY** clean and reassemble the filter tub. If applicable, replace the Magnepad **FILTER PAD ENVELOPE** by following procedures on page 17.

## 2. FRYER BOIL-OUT

- a. **BOIL-OUT** each fryer following cleaning instructions contained in the Cleaning Manual provided by your approved chemical supplier. The following are generic procedures:
  - 1) Ensure all Drain Levers are in the closed (**UP**) position, then add water to each vat until it reaches a point 2” (51 mm) **BELOW** the middle line of the “E ← ” in the word **LEVEL** of the **UPPER** shortening level mark on the rear wall of the vats.

**WARNING: ONLY USE A COMMERCIAL GRADE “NON-CHLORINE” BOIL-OUT COMPOUND!!**

- 2) Add the amount of **BOIL-OUT COMPOUND** in each fryer vat as prescribed in the Cleaning Manual provided by the Chemical Supplier.
- 3) Turn the Toggle ON/OFF switch for each fryer vat to the **ON** position; then depress the Computer ON/OFF Key to the **ON** position.

**NOTE:** The Drain Lever must be in the closed **UP** position to turn the computer **ON**.

- 4) Place the Computer in the **BOIL MODE** by pressing the following Computer keys in the order shown:

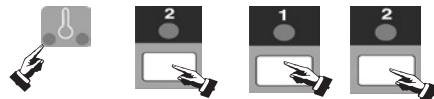

**NOTE:** **BOIL 30:00** will appear in the Computer display and the Computer will turn the Ultrafryer ON and OFF to heat and maintain the boil-out solution at 192°F (89°C).

- 5) Frequently scrub the sides, front and rear of each fryer vat with a long handled synthetic bristle scrub brush.
- 6) After the boil-out solution has “**BOILED**” for 30 minutes and the alarm sounds, press the  key to **EXIT BOIL MODE**.
- 7) Turn the Toggle ON/OFF Switch for each fryer to their **OFF** position and **CAREFULLY** dispose of the boil-out solution in each fryer in a floor drain.

**NOTE:** Do not use the filter pump to remove water from the vats as this will cause premature pump failure and void the pump warranty.

- 8) Use a scrubbing pad to remove carbon buildup from the top of the heat mechanism. To remove carbon buildup on the sides and bottom of the heat mechanism; slide one end of a stropping pad under each heat mechanism, grasp that end with a pair of tongs, and rock the pad up and down along the length of each heat mechanism until all encrusted material has been removed.
- 9) Rinse each fryer with hot water until the water coming out of the drain valve is clear.
- 10) Mix a solution of **ONE PART** vinegar to **25 PARTS** of water. Place this mixture into a one gallon garden pressure sprayer; and **THOROUGHLY** spray this solution onto the **SIDES, HEAT MECHANISM,** and **BOTTOM** of each fryer to neutralize the Boil-Out Compound.

**NOTE:** Boil-Out Compound will cause shortening to break down rapidly if it is not neutralized.

- 11) **THOROUGHLY** wipe the sides, heat mechanism, and bottom of each fryer with clean, lint-free, dry towels to remove any remaining water; then fill each fryer with **NEW** shortening following procedures on page 5 of this manual.
- 12) After the fryer has been filled with new shortening, place the computer in the **FEATURE PROGRAMMING MODE** and set the **DISPOSAL HIT COUNT ( DHC ##### )** to "0" to clear the **DISPOSE PROMPT** ; then press the **SET** key on the computer to exit the programming mode and return to normal operation.

**INTERMEDIATE SEDIMENT FLUSH** - To reduce the amount of sediment and debris build-up in vats used to cook **BATTERED CHICKEN** between filtering routines, it is recommended that the **VAT SWEEPER NOZZLE** be activated after cooking **480** pieces (10 drops of 48 pieces) of battered chicken. To perform an intermediate sediment flush; turn the Toggle ON/OFF Switch to the fryer vat **OFF**, and **ENSURE** the Suction Line Hose Assembly is securely connected to the filter screen **STANDPIPE** and fryer **BULKHEAD SUCTION COUPLING** as shown below.

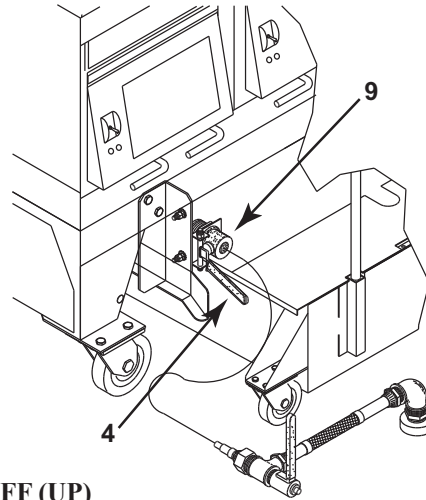
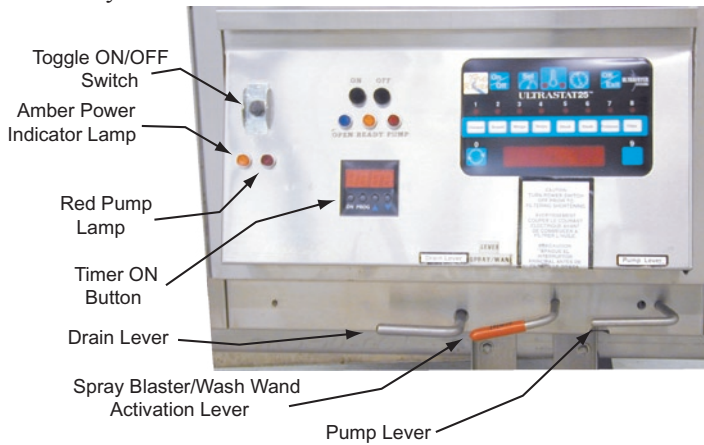

**CAUTION: PRIOR TO PROCEEDING TO STEP 1 ENSURE THE PUMP LEVER ON ALL OTHER FRYER VATS ARE IN THE OFF (UP) POSITION.**

<u>STEP</u>	<u>ACTION</u>	<u>RESPONSE</u>
1	Turn the Toggle ON/OFF Switch to the fryer vat <b>OFF</b> .	
2	Scrape <b>ALL</b> sides of the fryer with a scraper to loosen encrusted material.	
3	<p><b>SLOWLY</b> turn the Drain Lever to the <b>DOWN “OPEN”</b> position, when the bottom of the filter tub is covered with about two (2) inches (51 mm) of shortening, <b>“SLOWLY” OPEN</b> the Drain Lever until shortening <b>DROPS</b> to the <b>TOP</b> of the heat mechanism; then,</p> <ol style="list-style-type: none"> <li>Turn the <b>PUMP LEVER</b> to the <b>DOWN “ON”</b> position.</li> <li>Set the <b>TIMER</b> for <b>TWO (2)</b> minutes.</li> </ol> <p><b>CAUTION: DO NOT FLUSH SHORTENING MORE THAN TWO (2) MINUTES.</b></p>	<ol style="list-style-type: none"> <li>The <b>RED “PUMP”</b> Lamp will <b>LIGHT</b>.</li> <li>Shortening in the filter tub will be pumped back into vat through the <b>SWEEPER</b> nozzle, <b>FLUSHING</b> sediment and debris to the drain opening.</li> </ol>
4	When the Timer sounds at the end of two (2) minutes, turn the Drain Lever to the <b>UP “CLOSED”</b> position.	1. Shortening in the filter tub will be returned to the vat.
5	When <b>ALL</b> shortening in the filter tub has been returned to the fryer vat, as indicated by the bubbling air at the rear of the vat, turn the <b>PUMP LEVER</b> to the <b>UP “OFF”</b> position.	<ol style="list-style-type: none"> <li><b>RED “PUMP”</b> Lamp will turn <b>OFF</b>.</li> <li>Check and, if applicable, add shortening to the vat until it is level with the <b>E ←</b> in the word <b>LEVEL</b> on the rear wall of the vat.</li> </ol>
6	Repeat steps 1 to 5 to perform an Intermediate Sediment Flush on other vats used to Cook Battered Chicken	
7	<p>When all Battered Chicken vats have been flushed:</p> <ol style="list-style-type: none"> <li>Remove the Filter Tub Assembly from beneath the fryer, clean and reassemble the filter tub assembly following the “After Filtering” procedures in the Cleaning Section on page 30.</li> <li>Replace the Filter Tub beneath the fryer and <b>SECURELY</b> connect the Suction Line Hose to the filter screen <b>STANDPIPE</b> and fryer <b>BULKHEAD SUCTION COUPLING</b>.</li> </ol>	

## **CLEANING**

**CLEANING** - Any item of equipment operates better and lasts longer when it is kept cleaned and properly maintained, and the **ULTRAFRYER** and **FILTER TUB ASSEMBLY** are no exception. Clean the Ultrafryer daily and weekly according to the applicable Electric Ultrafryer Operations manual. Clean the **FILTER SCREEN** after Filtering Shortening and at Closing; and **THOROUGHLY** clean the **FILTER TUB ASSEMBLY** each **DAY** and **WEEK** as described below.

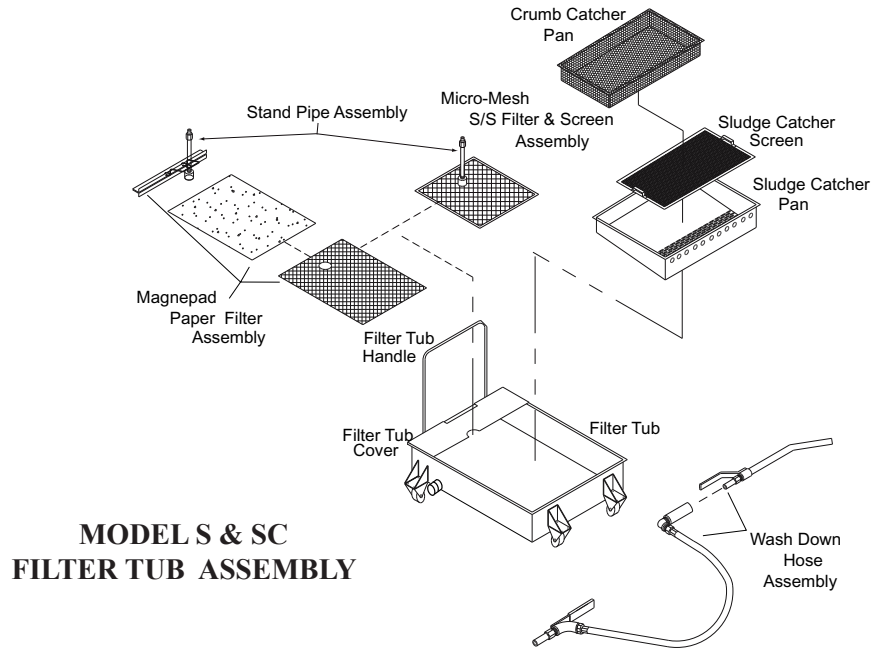

**MODEL S & SC  
FILTER TUB ASSEMBLY**

**NOTE:** With the exception of the Stainless Steel Micro-Mesh Filter Screen and **OPTIONAL** Magnepad Paper Filter Assemblies, all S & SC Filter Tub Assemblies are identical.

**A. Daily**

1. Clean the Filter Tub and Filter Assembly after **FILTERING** and **AT CLOSING** as follows:

a. After Filtering Shortening:

- 1) Disassemble the Filter Tub by removing the following items in the order listed; (1) **CRUMB CATCHER PAN, SLUDGE CATCHER PAN and SCREEN**, (2) **FILTER TUB HANDLE**, (3) **COVER**, (4) **WASH DOWN HOSE**, (5) **SUCTION LINE HOSE**, and (6) **FILTER ASSEMBLY**.
- 2) Clean the Suction Line Hose and Wash Down Hose with sanitizer solution; then hang these hoses in an upright position so any shortening can drain into a container.
- 3) Discard crumb fragments in the Crumb Catcher Pan and **THOROUGHLY** clean the pan with **HOT** water and let it air dry.
- 4) Remove sludge from the Sludge Catcher Screen and Pan using a scraper and **THOROUGHLY** clean these items with **HOT** water and allow them to air dry.
- 5) Raise the Filter Assembly above the Filter Tub and let any sediment or shortening drain into the tub; then **THOROUGHLY** clean the filter assembly as follows:

a) “Micro-Mesh” Stainless Steel Filter Screen

- (1) **CAREFULLY** remove any debris from the screen using a scraper.
- (2) Remove the **STANDPIPE** and **KNURL** knob from the **FILTER SCREEN** assembly, grasp the **FINGER LOOP** on **FRAME A** and adjacent **FINGER LOOP** on **FRAME B**, **EVENLY** pull the frames apart; then **HINGE** **FRAME A** to remove it from the **FILTER SCREENS** **FIRST**.
- (3) Grasp the **FINGER LOOP** on the straight side of **FRAME B**; then **HINGE** it to remove **FRAME B** from the **FILTER SCREENS**.
- (4) Separate the **UPPER FILTER SCREEN** and **BAFFLE** from the **LOWER FILTER SCREEN**.
- (5) **CAREFULLY** clean the two frames, screens and baffle in the 3 compartment sink with hot water and allow these items to air dry. **DO NOT USE SOAP**. If necessary the channels in each frame can be cleaned with the edge of a scotch-brite pad.
- (6) Insert the **SUCTION FITTING** on the **BAFFLE** in the hole of the **UPPER FILTER SCREEN**; then place these items on top of the **LOWER FILTER SCREEN**.
- (7) **ENSURE** all sides of the **FILTER SCREEN** assembly are aligned, place the **PIN** end of **FRAME A** on the **FILTER SCREENS**, place the **CHANNEL** on the frame adjacent to the **PIN** end over the **FILTER SCREENS**; then **HINGE** the frame so the edge of the **FILTER SCREENS** are inserted in the other **CHANNEL** of **FRAME A**.

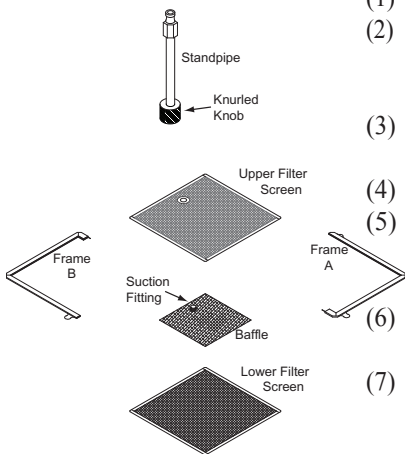

- (8) Place the **PIN** end of **FRAME B** on the **FILTER SCREENS** so the **PIN** is seated in the **CHANNEL** of **FRAME A** near the **FINGER LOOP**, place the **CHANNEL** on the frame adjacent to the **PIN** end over the edge of the **FILTER SCREENS**; then **HINGE** the frame so the edge of the **FILTER SCREENS** are inserted in the other **CHANNEL** of **FRAME B** and the **PIN** of **FRAME A** is seated in the **CHANNEL** of **FRAME B**.
- (9) Adjust **FRAME A** and **B** so both **PINS** are properly seated in the **CHANNEL** of the opposite frame; then **CAREFULLY** connect the **KNURL KNOB** and **STANDPIPE** to the **SUCTION FITTING** on the **FILTER SCREEN** assembly. **DO NOT OVERTIGHTEN!!!**
- b) “Magnepad Paper Envelope” Filter: Magnepad Paper Filter Assemblies **DO NOT** have to be **SCRAPED** after filtering shortening.
- 6) Remove any sediment and shortening in the Filter Tub using a scraper; then wipe the tub dry with paper towels.
- 7) Carefully insert the Filter Assembly in the bottom of the Filter Tub with the **STANDPIPE** centered in the handle end of the tub.

**WARNING: WHEN ASSEMBLED, ENSURE THERE ARE NO FINGER LOOPS ON THE STANDPIPE SIDE OF THE FILTER.**

- 8) **CAREFULLY** insert the Sludge Catcher Screen and Pan in the Filter Tub; then replace the Crumb Catcher Pan.
- 9) Install the assembled Filter Tub Assembly on the filter tub guides beneath the fryer; then **SECURELY** connect the Suction Hose Assembly to the **STANDPIPE** on the Filter Screen and the **BULKHEAD SUCTION COUPLING** on the Fryer as shown to the right.

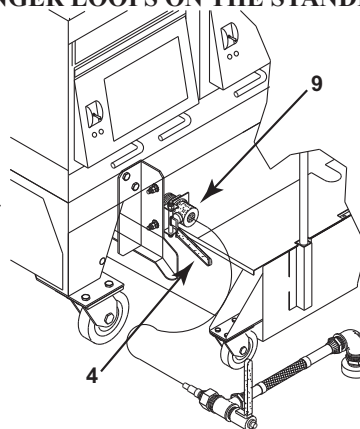

b. At Closing

- 1) Repeat **DAILY** steps A 1 a 1) thru A 1 a 5) above.
- 2) **THOROUGHLY** clean the Filter Assembly as follows:
  - a) “Micro-Mesh” s/s Filter Screen:
    - (1) **THOROUGHLY** flush any remaining sediment from both sides of the filter screen with **HOT WATER**.
    - (2) Remove the **STANDPIPE** and **KNURL** knob from the **FILTER SCREEN** assembly, grasp the **FINGER LOOP** on **FRAME A** and adjacent **FINGER LOOP** on **FRAME B**, **EVENLY** pull the frames apart; then **HINGE FRAME A** to remove it from the **FILTER SCREENS** **FIRST**.
    - (3) Grasp the **FINGER LOOP** on the straight side of **FRAME B**; then **HINGE** it to remove **FRAME B** from the **FILTER SCREENS**.
    - (4) Separate the **UPPER FILTER SCREEN** and **BAFFLE** from the **LOWER FILTER SCREEN**.
    - (5) **CAREFULLY** clean the two frames, screens and baffle in the 3 compartment sink with hot water and allow these items to air dry. **DO NOT USE SOAP**. If necessary the channels in each frame can be cleaned with the edge of a scotch-brite pad.
    - (6) Insert the **SUCTION FITTING** on the **BAFFLE** in the hole of the **UPPER FILTER SCREEN**; then place these items on top of the **LOWER FILTER SCREEN**.
    - (7) **ENSURE** all sides of the **FILTER SCREEN** assembly are aligned, place the **PIN** end of **FRAME A** on the **FILTER SCREENS**, place the **CHANNEL** on the frame adjacent to the **PIN** end over the **FILTER SCREENS**; then **HINGE** the frame so the edge of the **FILTER SCREENS** are inserted in the other **CHANNEL** of **FRAME A**.
    - (8) Place the **PIN** end of **FRAME B** on the **FILTER SCREENS** so the **PIN** is seated in the **CHANNEL** of **FRAME A** near the **FINGER LOOP**, place the **CHANNEL** on the frame adjacent to the **PIN** end over the edge of the **FILTER SCREENS**; then **HINGE** the frame so the edge of the **FILTER SCREENS** are inserted in the other **CHANNEL** of **FRAME B** and the **PIN** on **FRAME B** is seated in the **CHANNEL** of **FRAME A**.
    - (9) Adjust **FRAME A** and **B** so other **PINS** are properly seated in the **CHANNEL** of the opposite frame; then **CAREFULLY** connect the **KNURL KNOB** and **STANDPIPE** to the **SUCTION FITTING** on the **FILTER SCREEN** assembly. **DO NOT OVERTIGHTEN!!!**
  - b) “Magnepad” Envelope Filter - Remove and discard the **USED** Filter Pad Envelope, **CAREFULLY** clean the Baffle Assembly and Clip / Standpipe Assembly in the 3 compartment sink with **HOT** water and allow these items to air dry. **DO NOT USE SOAP!!** Re-assemble the Magnepad Envelope Filter using a **NEW** Filter Pad Envelope as follows:

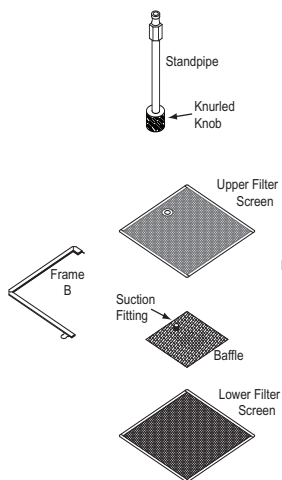

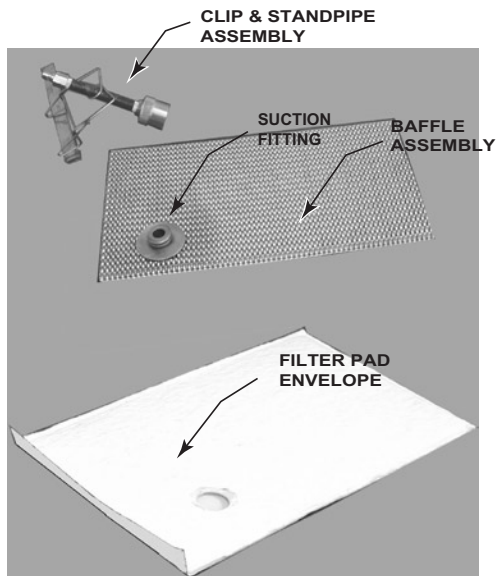

- (1) Insert the **BAFFLE** into the **FILTER PAD ENVELOPE**, when inserted properly the **SUCTION FITTING** will protrude through the hole in the pad.
- (2) Fold **FLAP** over (in the direction of the hole), securing the Baffle inside the **FILTER PAD ENVELOPE**.
- (3) **CAREFULLY**, align the **CLIP & STANDPIPE ASSEMBLY** so that the **CLIP** can secure the **FLAP** on the Envelope and the **STANDPIPE** will align over the **SUCTION FITTING** protruding through the Envelope.
- (4) Tighten the knurled **NUT** on the **STANDPIPE** to the **SUCTION FITTING** protruding through the Envelope.

3) Repeat **DAILY** steps A1 a 6) through steps A1 a 9) page 35.

## B. WEEKLY

1. Perform the daily cleaning steps A 1 a 1) through A 1 a 5) page 34.
2. Clean the Filter Assembly as follows:
  - a) "Micro-Mesh" stainless steel filter screen:
    - 1) Disassemble the filter according to **DAILY** steps A 1 a 5) a) (1) through A 1 a 5) a) (4) and clean the two (2) frames as described in step A 1 a 5) a) (5) page 34.
    - 2) Place the upper and lower **FILTER SCREENS** in the fryer with **BOIL-OUT SOLUTION** for cleaning. **DO NOT PLACE THE BAFFLE OR STANDPIPE IN THIS SOLUTION!!!** **BOIL-OUT** the fryer vat according to instructions contained in the cleaning manual provided by your chemical supplier.
    - 3) After the filter screens have been cleaned in the Boil-Out Solution, **ENSURE** they are **THOROUGHLY** sprayed with a solution of **1 PART** vinegar to **25 PARTS** of water to **NEUTRALIZE** the boil-out solution, then allow the screens to air dry. **NOTE:** any residue of boil-out solution on the filter screens could cause the rapid break-down of the shortening.
    - 4) Reassemble the "Micro-Mesh stainless steel filter screen according to **DAILY** steps A 1 a 5) a) (6) through A 1 a 5) a) (9) page 34.
  - b) "Magnepad" Envelope Filter - Disassemble, clean, and re-assemble the "Magnepad" Filter Assembly according to **DAILY** cleaning steps A 1 b 2) b) above.
3. Place the **CRUMB CATCHER PAN** and **SLUDGE CATCHER SCREEN** in the fryer with the Boil-Out Solution for cleaning, and after they are cleaned, **ENSURE** they are sprayed with a solution of vinegar/water as described in **WEEKLY** step B2 a) 3) above.
4. **THOROUGHLY** clean the Filter Tub, Cover and Sludge Catcher Pan with **HOT SANITIZER SOLUTION** and allow them to air dry.
5. Re-assemble the Filter Tub according to **DAILY** steps A 1 a 6) through A 1 a 9) (page 35).

**WARNING: WHEN ASSEMBLED, ENSURE THERE ARE NO FINGER LOOPS ON THE STANDPIPE SIDE OF THE MICRO-MESH FILTER.**

## **SERVICE AND PARTS**

1. **TECHNICAL ASSISTANCE** - Contact an authorized service agent or the Customer Service Department, Ultrafryer Systems at 1-800-525-8130 for technical assistance.

2. **ORDERING INFORMATION:**

A. **REPLACEMENT PARTS** - Provide the following information when ordering replacement parts by phone, fax or mail:

Your company name and phone number  
Your company purchase order number  
Bill-to address  
Ship-to address  
Quantity desired  
Part number and description of the desired-item  
Your name or signature of authorized-buyer  
Phone in order to: 1-800-545-9189 Ext 5029  
FAX order to: 1-210-731-5099  
Mail order to: Ultrafryer Systems  
Order Entry Office  
P.O. Box 5369  
San Antonio, TX 78201  
E-Mail your order to: Ultrafryerservice@afce.com

B. **TERMS** - Net 30 days for customers on open accounts. Past due balances will be charged 1 1/2% per month (18% per annum) until full balance is paid.

C. **DAMAGES** - Ultrafryer Systems is not responsible for damage occurring in transit. All deliveries must be inspected for damage to shipping containers prior to departure of the delivering carrier. Any damage must be notated on the receiving document to facilitate filing of freight claims. Carriers must be notified immediately and freight inspections must be requested from the carrier. Ultrafryer Systems can and will gladly assist you in preparing and processing of the necessary claims only if proper notification has been accomplished on the carrier delivery document. Damaged equipment and or containers must be available for the claims inspector to inspect.

D. **RETURNS** - Ultrafryer Systems cannot guarantee credit for items returned without proper authorization. All returns must have prior Ultrafryer Systems Customer Service or Warranty department approval. An assigned number will be issued by the approval authority. Please print the assigned number on all returned packages and corresponding paperwork. Returned goods are subject to a 15% restocking charge. Ultrafryer Systems is not responsible for freight charges on returned goods unless authorized by Customer Service and or Warranty personnel. Ultrafryer Systems does not receive freight collect or C.O.D. shipments.

3. **PARTS IDENTIFICATION** - Locate the part on the following sketches and note the index number i.e, 4, 7, etc; then obtain the part number and description for that index number on the right side of the page facing the sketch. Use that part number when ordering a replacement part.

**THIS PAGE IS INTENTIONAL BLANK**

**MODEL EUS & SC FRONT VIEW  
PANEL OPEN & PANEL CLOSED**



**MODEL EUS & SC REAR VIEW**

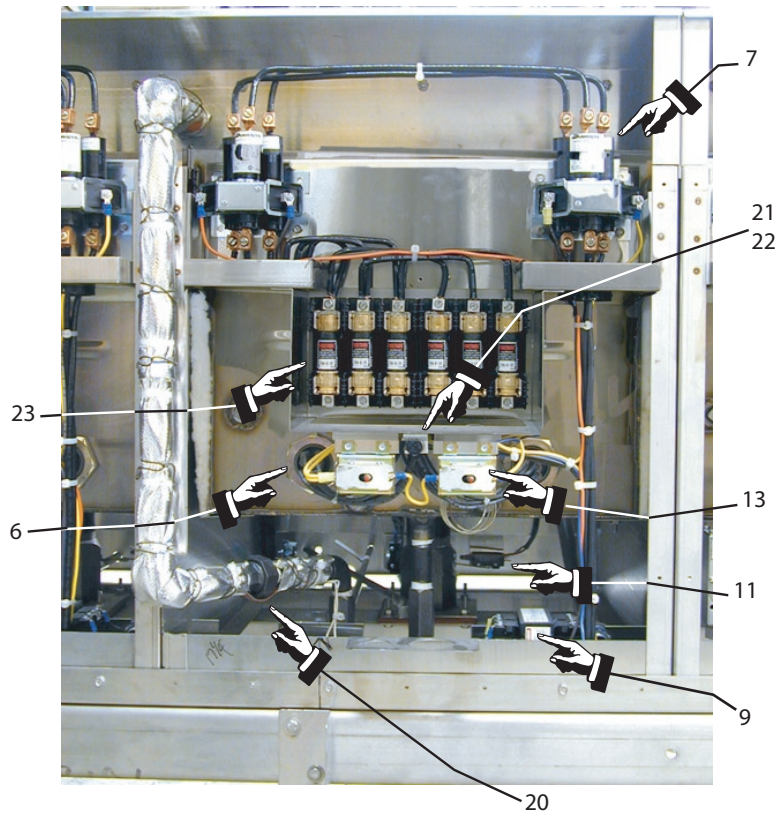

<u>ITEM</u>	<u>DESCRIPTION</u>	<u>PN</u>
1	2" (51mm) Drain Valve for EUS - 18/20" Electric Fryers (Uses Gasket PN <a href="#">22A119</a> ). 1 1/4" (32mm) Drain Valve for EUS - 14" Electric Fryers (Uses Gasket PN <a href="#">22A119</a> ).	12-775 <a href="#">12A483</a>
* 2	Drain Clean-out Rod.	12-569
3	Filter Valve Lever for EUS-14" Electric Fryer. Filter Valve Lever for EUS-18" Electric Fryer. Filter Valve Lever for EUS-20" Electric Fryer.	<a href="#">12A223</a> <a href="#">19A617</a> 19A618
4	<b>RED</b> Handle Spray Blaster/Wash Wand Activation Lever for EUS-14 Electric Fryer. <b>RED</b> Handle Spray Blaster/Wash Wand Activation Lever for EUS-18 Electric Fryer. <b>RED</b> Handle Spray Blaster/Wash Wand Activation Lever for EUS-20 Electric Fryer.	<a href="#">12A474</a> <a href="#">19B060</a> 19A946
5	Drain Ball Valve Lever for EUS-14 Electric Fryer. Drain Ball Valve Lever for EUS-18/20 Electric Fryer.	12A476 <a href="#">12A477</a>
6	Heat Element Teflon Washer.	18-174
7	208/240 Volt 3 Ø 60 Ampere Mercury Contactor w/24 Volt Resistive Coil for all versions of Fryers	18-231
8	Type K 120 to 24 Volt 100 KVA Square D Step Down Transformer for all versions of Fryers.	<a href="#">18A010</a>
9	208 Volt, 3 Ø, 8.5 KW Heat Element for EUS-14 Electric Fryer. 208 Volt, 3 Ø, 10 KW Heat Element for EUS-18/20 Electric Fryer. 240 Volt, 3 Ø, 8.5 KW Heat Element for EUS-14 Electric Fryer 240 Volt, 3 Ø, 10 KW Heat Element for EUS-18/20 Electric Fryer.	<a href="#">18A012</a> <a href="#">18A013</a> <a href="#">18A014</a> <a href="#">18A015</a>
10	Drain Valve Lever Microswitch mounting bracket for all EUS Electric Fryers.	<a href="#">19A104</a>
*11	Heat Element Support Bracket for all EUS-18 Electric Fryer. Heat Element Support Bracket for all EUS-20 Electric Fryer. Heat Element Support Bracket for all EUS-14 Electric Fryer.	<a href="#">19A117</a> <a href="#">19A118</a> <a href="#">19A178</a>
12	Hi-Limit Switch mounting bracket for all EUS Electric Fryers.	19A132
13	Hi-Limit Switch Pre-Set to trip at 450° F (232°C) for all EUS-18/20 Electric Fryers (NOTE1). Hi-Limit Switch Pre-Set to trip at 435° F (224°C) for all EUS-14 Electric Fryers (NOTE1).	<a href="#">19A145</a> <a href="#">19A193</a>
*14	Hi-Limit Switch Probe Holder for all EUS Electric Fryers.	<a href="#">19A788</a>
*15	Basket Hanger Bracket for all EUS-14 Electric Fryer. (NOTE 2) Basket Hanger Bracket for all EUS-18 Electric Fryer. (NOTE 2) Basket Hanger Bracket for all EUS-20 Electric Fryer. (NOTE 2)	19A949 <a href="#">19A950</a> <a href="#">19A951</a>
*16	Hi-Voltage Terminal Block for all EUS Electric Fryers.	22-544
*17	19 1/4" x 19 1/4" (489 mm x 489 mm) Vat Grill for EUS-20 Electric Fryer. 13 1/4" x 13 1/4" (337 mm x 337 mm) Vat Grill for EUS-14 Electric Fryer. 17 1/4" x 17 1/4" (438 mm x 438 mm) Vat Grill for EUS-18 Electric Fryer.	22-671 22-703 22-704
*18	Hexagon Neoprene Pump/Motor Bushing for all EU Electric Fryers.	22-769
*19	Type SJO 16/3 Electric Cord with Molded Plug for all EU Electric Fryers.	23-221
20	120 Volt 75 Watt Silicon Rubber Heater Tape 5' (1352 mm) for all EU Electric Fryers.	23-341
21	Type AP-2 Fuse Holder Assembly for all EU Electric Fryers.	23-373
22	Buss Type AGC-8 8 Ampere Fuse for all EU Electric Fryers.	23-374
23	Class RK5 35 Ampere 250 Volt Time Delay Fuse for EU-18/20 Electric Fryers.	<a href="#">23A043</a>
24	250 Volt 60 Ampere 3 Pole Fuse Block for EU-18/20 Electric Fryers.	<a href="#">23A044</a>
25	1/2" (13mm) Filter System Ball Valve for all EU Electric Fryers.	24-036
*26	Model GPV-0519 7.7 GPM (29.26 LPM) Viking Pump/Motor for all EU 18" & 20" Fryers. <b>NOTE:</b> For replacement Baldor Motor & Bracket Kit order PN 12B129 and for Pump Only order PN 34-329. Model GPV-0514 5.5 GPM (19.25 LPM) Viking Pump/Motor for all EU14 Electric Fryers. <b>NOTE:</b> For replacement Baldor Motor & Bracket Kit order PN 12B129 and for Pump Only order 24-339.	24A183 <a href="#">24A184</a>
*27	Medium Duty 4" (102mm) Front Caster w/Brake for all EU Electric Fryers.	28-015
*28	Medium Duty 4" (102mm) Rear Caster w/o Brake for all EU Electric Fryers.	28-016
*29	"L" Shaped Tip cleaning Brush for all EU Electric Fryers.	<a href="#">29A044</a>
*30	Nema 5-15R/L5-15R Dual Electrical Receptacle for all EU Electric Fryer Banks.	<a href="#">33A005</a>

**Model EUS & SC Center Drain Replacement Vats:**

<u>VAT SIZE</u>	<u>VAT DEPTH</u>	<u>PN</u>
14" (356 mm)	Standard 6 <sup>5</sup> / <sub>8</sub> " (168 mm)	12A715
18" (457 mm)	Standard 9" (229 mm)	12A747
20" (508 mm)	Standard 9 <sup>3</sup> / <sub>8</sub> " (238 mm)	12A748

**Model EUS & SC Front Drain Replacement Vats:**

<u>VAT SIZE</u>	<u>VAT DEPTH</u>	<u>PN</u>
14" (356 mm)	Shallow 7 <sup>3</sup> / <sub>8</sub> " (187 mm)	12A749
18" (457 mm)	Standard 9 <sup>3</sup> / <sub>16</sub> " (223 mm)	12A750
20" (508 mm)	Standard 9 <sup>3</sup> / <sub>16</sub> " (223 mm)	12A751

**BULKHEAD SUCTION COUPLING**

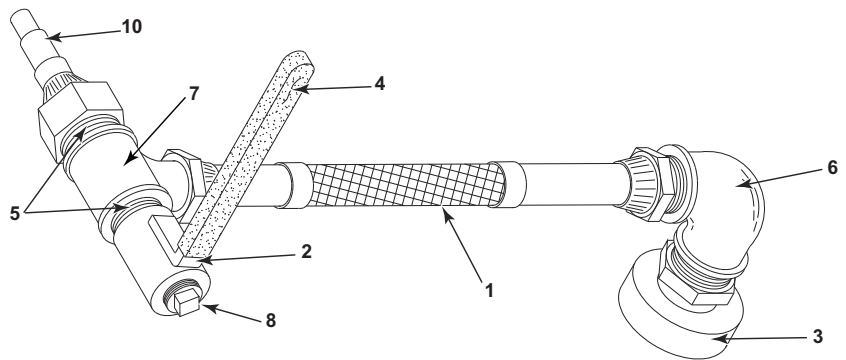
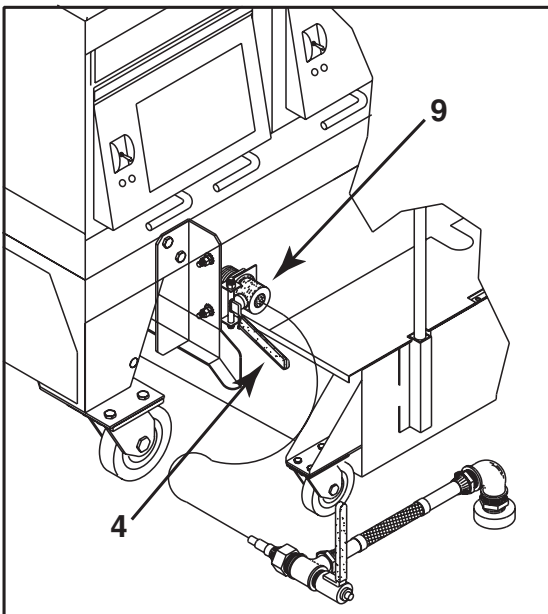

**SUCTION HOSE ASSEMBLY**  
PN 12A912

<u>ITEM</u>	<u>DESCRIPTION</u>	<u>PN</u>
1	<b>NSF APPROVED</b> 1/2" (13 mm) x 10 1/2" (267 mm) Long, Food Grade wire reinforced Hose w/Fittings for all EU Fryers	12A276
2	Suction Line Hose Handle Assembly	19A932
3	Female Quick-Connect Fitting	22-677
4	Cool Handle II Grip	22-734
5	1/2" (13 mm) Closed Black Iron Nipple	24-003
6	3/8" (10 mm) x 90° w/1/2" (13 mm) NPT Internal Threads Black Iron Street Elbow	24-376
7	1/2" x 1/2" x 1/2" (13 x 13 x 13 mm) Black Iron Tee	24A083
8	1/2" (13 mm) Black Iron Square Head Plug	24A084
9	1/2" (13 mm) FPT S/S Female Bulkhead Coupling w/raised Push Button Release	24A157
10	1/2" (13 mm) FPT x 2 7/8" (73 mm) Long S/S In-Line Male Plug	24A160

## MODEL EUS & SC ELECTRIC FRYER TEMPERATURE CONTROL ACCESS PANELS

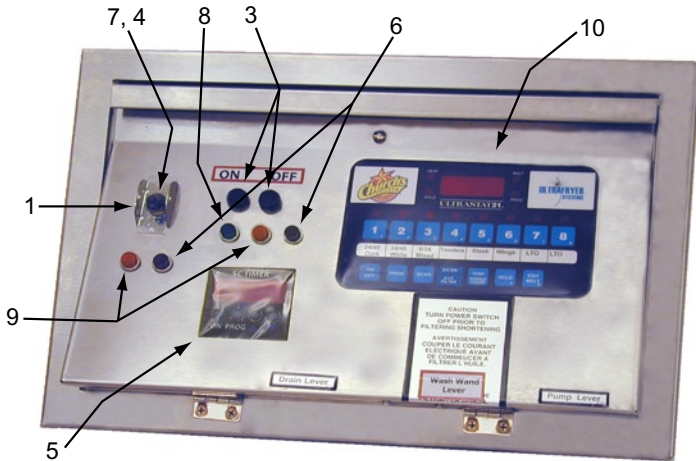

**PANEL WITH DIGITAL TIMER**

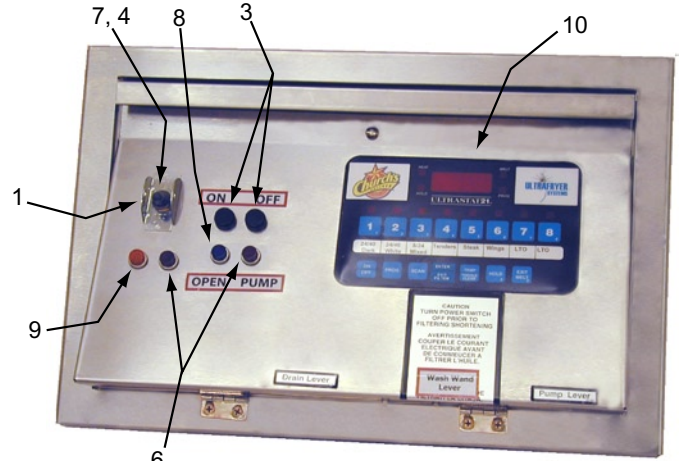

**PANEL WITHOUT DIGITAL TIMER**

<u>ITEM</u>	<u>DESCRIPTION</u>	<u>PN</u>
1	On/Off Toggle Switch Guard.	18-129
* 2	120 Volt Control Relay.	<a href="#">18A020</a>
3	120 Volt Momentary Push Button Switch.	<a href="#">18A054</a>
4	120 Volt 6 Amp SPDT Toggle ON/OFF Switch.	<a href="#">18A287</a>
5	125 Volt Model T-10R Digital SC Timer.	21A269
6	125 Volt 1/3 Watt Snaplight w/ <b>RED</b> Lens.	23-362
7	Toggle ON/OFF Switch Protective Boot.	23-402
8	125 Volt 1/3 Watt Snaplight w/ <b>BLUE</b> Lens.	<a href="#">23A054</a>
9	125 Volt 1/3 Watt Snaplight w/ <b>AMBER</b> Lens.	<a href="#">23A056</a>
10	<b>ULTRASTAT COOKING COMPUTERS</b> Ultrastat 21 Cooking Computer (Uses Temperature Probe <a href="#">18A006</a> ) Ultrastat 25 Cooking Computer (Uses Temperature Probe <a href="#">18A006</a> )	Note Note

\* Item Not Shown

**NOTE:** To obtain a replacement “PROGRAMMED” Ultrastat Cooking Computer contact the Customer Service Department at **1-800-525-8130** and provide the following information:

**TYPE STORE:** CHURCHS, POPEYES COMPANY, POPEYES FRANCHISE, ETC.  
**TYPE FRYER:** ELECTRIC OR GAS  
**PRODUCT:** CHICKEN, FRENCH FRIES, ETC.

**MODEL EUS & SC FILTER TUB ASSEMBLY**  
**PN 11A830 w/Micro-Mesh Filter - PN 11A882 w/Magnepad Filter**

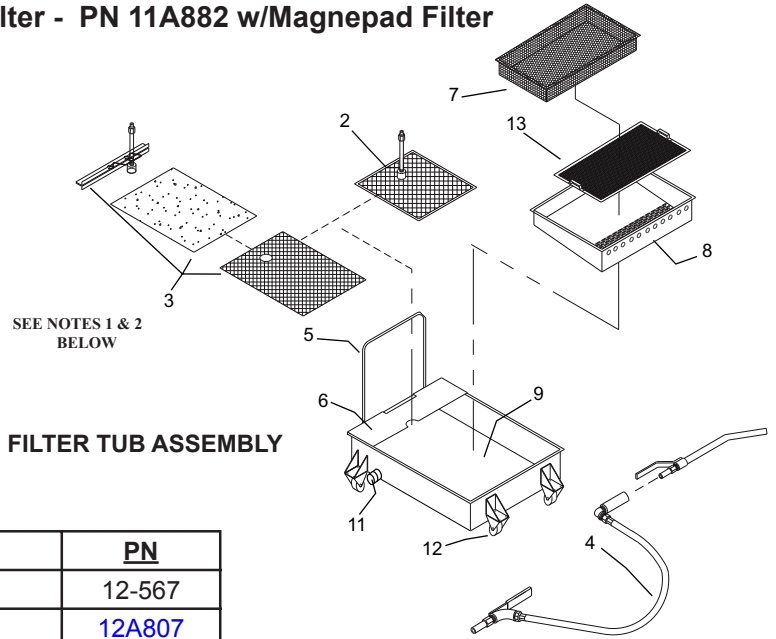

<b>ITEM</b>	<b>DESCRIPTION</b>	<b>PN</b>
* 1	Filter tub Scraper	12-567
2	Micro-Mesh S/S Filter Assembly (Note 1)	<a href="#">12A807</a>
3	Magnepad Paper Filter Assembly (Note 2)	<a href="#">12A813</a>
4	Wash Down Hose Assembly	<a href="#">12A850</a>
5	Filter Tub Handle	19-423
6	Filter Tub Cover	<a href="#">19A481</a>
7	Crumb Catcher Pan	<a href="#">19A796</a>
8	Sludge Catcher Pan	<a href="#">19A797</a>
9	Universal Filter Tub	<a href="#">19A801</a>
*10	1¼" (32 mm) Boil-out Drain Ball Valve (Optional)	<a href="#">24A069</a>
11	1¼" (32 mm) Black Iron Pipe Cap	<a href="#">24A152</a>
12	Medium Duty Caster	28A005
13	Sludge Catcher Screen	<a href="#">29A045</a>

\* Item not shown

Notes: 1) Micro-Mesh S/S Filter PN [12A807](#) is provided with Filter Tub Assembly PN 11A830.

2) Magnepad Paper Filter Assembly PN [12A813](#) is provided with Filter Tub Assembly PN 11A882

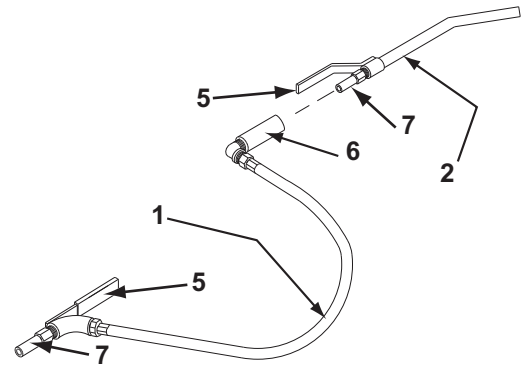

<b>ITEM</b>	<b>DESCRIPTION</b>	<b>PN</b>
1	6 ft (1829mm) Wash Down Hose w/Fittings	12-541
2	Wash Down Handle & Nozzle	<a href="#">12A852</a>
3	Hose Quick Disconnect Assembly	19-248
4	Black Ball Knob	22-620
5	Cool II Handle	22-734
6	½" (13 mm) Female S/S Locking Seal Coupling	<a href="#">24A158</a>
7	½" (13 mm) Male S/S Locking Seal Plug	24A160

**WASH DOWN HOSE ASSEMBLY**  
**PN [12A850](#)**

**MICRO MESH FILTER SCREEN ASSEMBLY**  
PN **12A807**

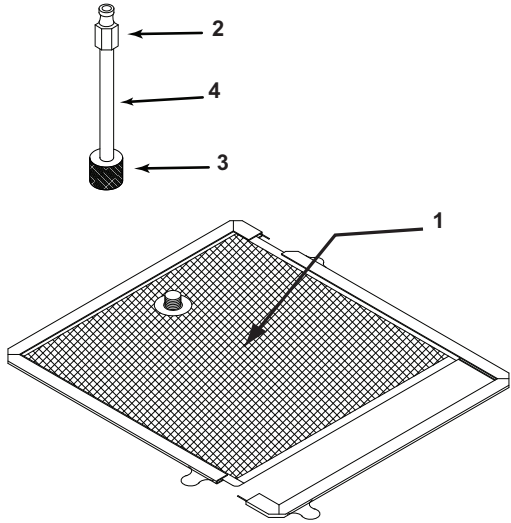

ITEM	DESCRIPTION	PN
1	Micro Mesh Filter Screen (see exploded view)	<a href="#">21A279</a>
2	3/8" (10 mm) NPT Male Stem Quick Connect Fitting	22-676
3	Top Compression Cap (Knurl Knob)	24-369
4	3/8" (10 mm) x 7" (178 mm) S/S Nipple	24-471

**NOTE: USED WITH FILTER TUB ASSEMBLY PN 11A783.**

**EXPLODED VIEW**

ITEM	DESCRIPTION	PN
1	Filter Screen Frame Set	22A280
2	Upper Filter Screen	<a href="#">21A281</a>
3	Baffle w/suction line fitting	<a href="#">21A282</a>
4	Lower Filter Screen	<a href="#">21A274</a>

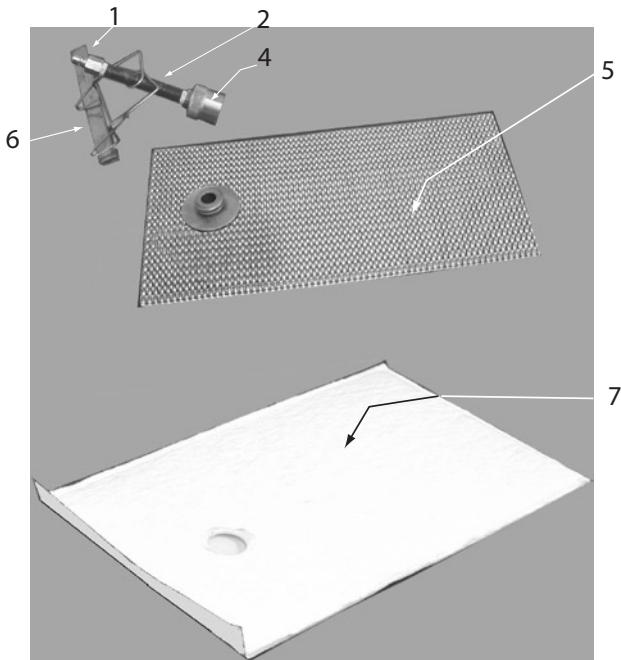
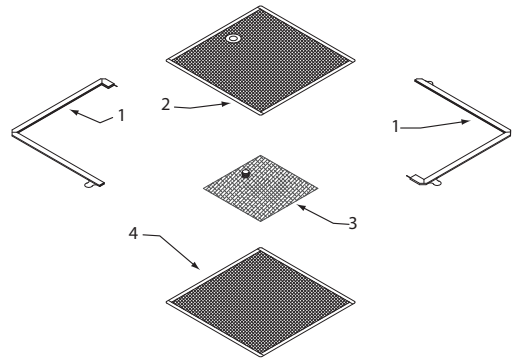

**MAGNEPAD FILTER ASSEMBLY**  
PN **12A813**

ITEM	DESCRIPTION	PN
1	3/8" (10mm) NPT Quick-Connect Male Stem Fitting	22-676
2	3/8" x 7" (10mm x 178mm) S/S Nipple	24-471
3	23" x 30 1/2" (597 x 775mm) Baffle Kit consisting of items 4, 5, & 6.	<a href="#">29A055</a>
4	Top Compression cap (Knurl Knob)	<a href="#">24A153</a>
5	21 1/2" x 29" (456 x 737mm) Baffle	29A049
6	23" (584mm) Long Standpipe Clip	29A051
7	23 1/2" (597mm) x 30" (762mm) Filter Pad	<a href="#">29A047</a>
*8	Case of 30 Filter Pads	<a href="#">29A053</a>

\* Not Shown

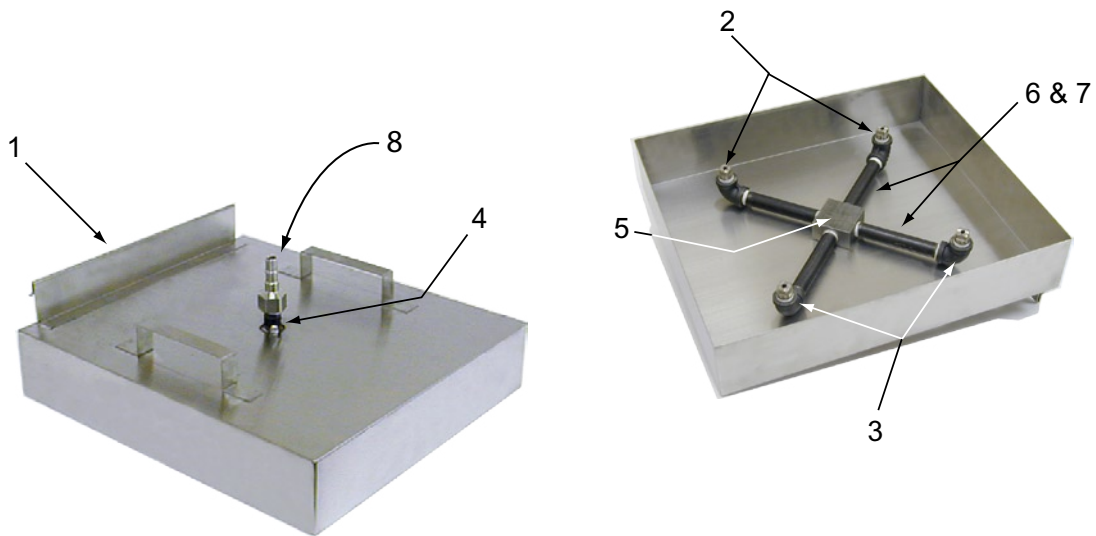

<b>ITEM</b>	<b>DESCRIPTION</b>	<b>PN</b>
1	Blaster, Spray 18½ x 20⅝" (470 x 524 mm) for 20" (508 mm) EUS Fryer Vat. Blaster, Spray 18¾ x 16⅞" (476 x 421 mm) for 18" (457 mm) EUS Fryer Vat. Blaster, Spray 13½ x 14" (343 x 356 mm) for 14" (356 mm) EUS Fryer Vat.	<a href="#">12A849</a> <a href="#">12A991</a> <a href="#">12B004</a>
2	Nozzle, Spray ½ HH - SS36SQ (all versions)	<a href="#">22A111</a>
3	Elbow, ½" (13 mm) x 90° Black Iron (all versions)	24-007
4	Nipple ½" x 2" (13 mm x 51 mm) Black Iron (all versions)	24-272
5	Manifold, 5 Way Crossover ½" Black Iron (all versions)	24A082
6	Nipple ½" x 5¼" (13 mm x 133 mm) Black Iron for 14" (356 mm) Spray Blaster PN <a href="#">12B004</a>	<a href="#">24A100</a>
7	Nipple ½" x 5¾" (13 mm x 146 mm) Black Iron for 18/20" (457/508mm) Spray Blaster PN <a href="#">12A849</a> & <a href="#">12A991</a>	<a href="#">24A101</a>
8	Plug, Male S/S In Line ½" (13 mm) FPT 1½" (38 mm) Diameter x 2⅞" (73 mm) long	24A160

## **WIRING DIAGRAMS**

**WIRING DIAGRAM** - Since minor wiring changes may occur in the future, **USE** the diagram pasted to the fryer for circuit tracing and/or trouble shooting.

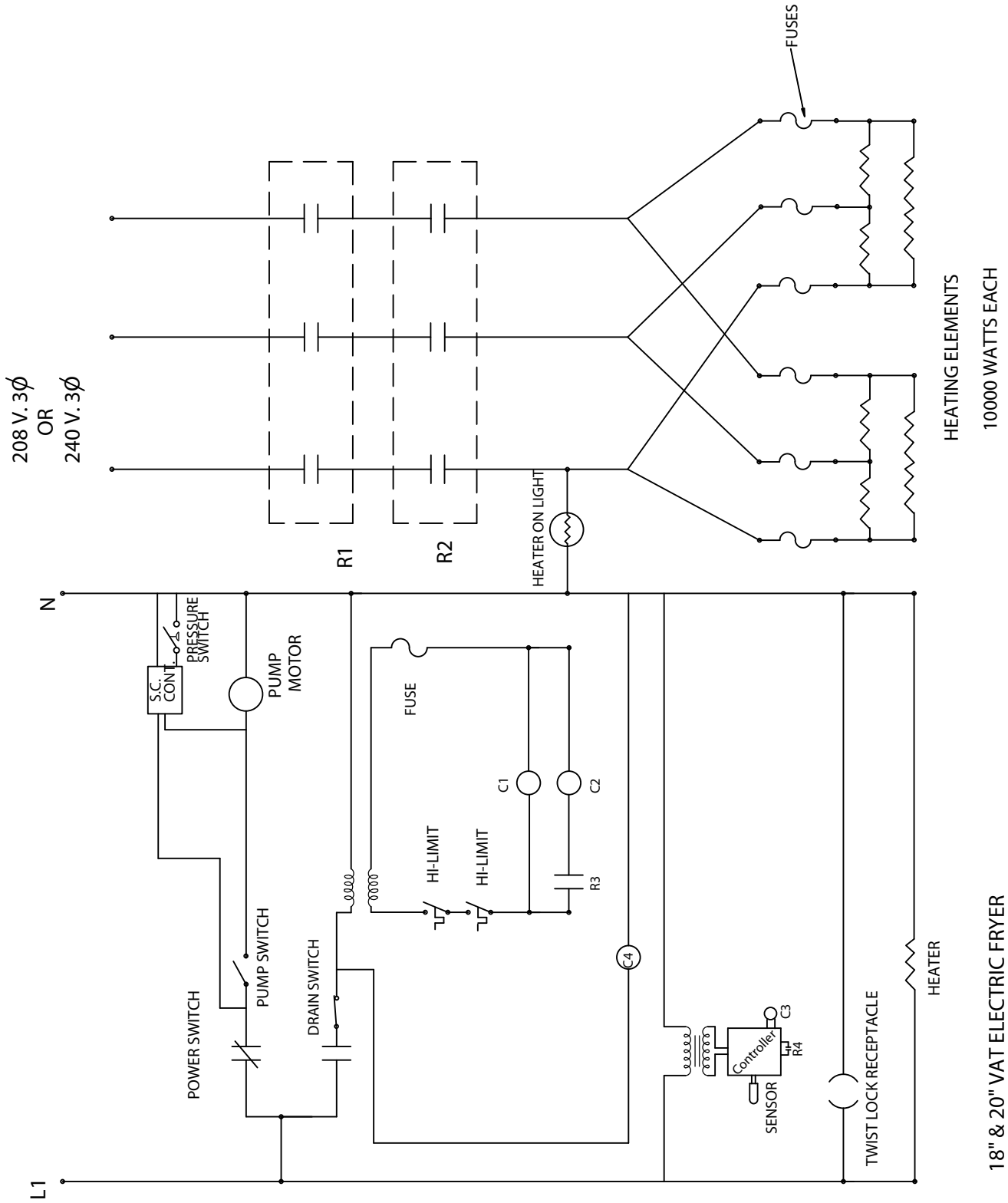

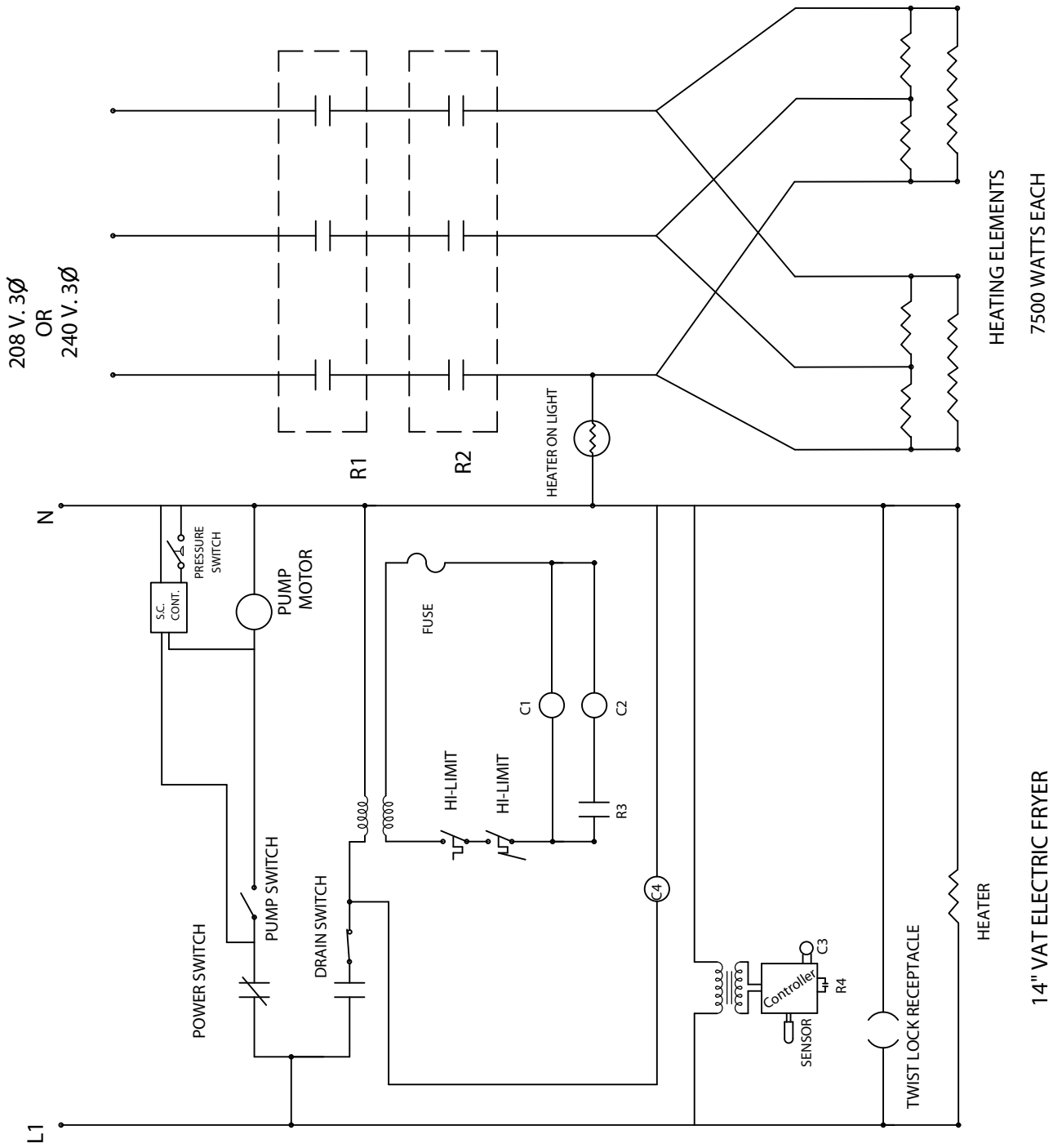

14" VAT ELECTRIC FRYER

MODEL EUS 14 ELECTRIC FRYER