

# Ultrafryer®

## High Performance Series Fryer Model F-ID-20x17 Operation Instructions



**WARNING:** California Residents Only. This product can expose you to chemicals including chromium which is known to the State of California to cause cancer and birth defects or other reproductive harm. For more information go to [www.P65Warnings.ca.gov](http://www.P65Warnings.ca.gov).



### FOR YOUR SAFETY

Do not store or use gasoline or other flammable vapors or liquids in the vicinity of this or any other appliance.

Purchaser to post in a prominent location instructions to be followed in the event the user smell gas.  
This information shall be obtained by consulting the local gas supplier.

### WARNING

Improper installation, adjustment, alteration, service, or maintenance can cause property damage, injury, or death.  
Read the installation, operating, and maintenance instructions thoroughly before installing or servicing this equipment.

302 Spencer Lane • P.O. Box 5369

(800) 525-8130 • (210) 731-5000 • Fax: (210) 731-5099

[www.ultrafryer.com](http://www.ultrafryer.com)

San Antonio, Texas 78201

## PREFACE

This manual was written and published by the Ultrafryer Systems Engineering Department for use by personnel who will operate a Model F-ID-20x17 Premix Gas Fryer equipped with an Ultrastat 23 Computer in a commercial cooking environment. Proper use of a manual will allow store employees to operate, clean, and maintain equipment properly, thereby reducing service call expenses.

**This appliance is intended for professional use and is to be operated by qualified personnel.**

**The manual is to be retained for future reference.**

Throughout this manual, NOTE, NOTICE, **WARNING**, **CAUTION** and **DANGER** are used to alert the operator to items of special circumstances. These items are identified as follows:

NOTE: Adequate clearances must be provided for servicing and proper operation.

NOTICE: Programming of an Ultrastat 23 Cooking Computer should only be performed by a store manager or area supervisor.

**WARNING: DISCONNECT THE ELECTRICAL POWER TO THE FRYER.**

**CAUTION: DO NOT ALLOW ANY CLEANING SOLUTION OR WATER TO SPLASH INTO A VESSEL OF HOT COOKING OIL, AS IT WILL CONTAMINATE THE OIL AND MAY CAUSE THE OIL TO SPLATTER, CAUSING SEVERE BURNS.**

**DANGER: THE FRYER MUST BE CONNECTED TO THE TYPE OF GAS IDENTIFICATION ON THE RATING PLATE**

*This manual is intended as a guide for all Model F-ID-20x17 Premix Gas Fryers, regardless of configuration and*

## TABLE OF CONTENTS

<b>GENERAL INFORMATION</b>	
Warranty.....	5
Safety.....	6
Description.....	6
Specifications.....	7
Operating Controls.....	7-8
Automatic Safety Features.....	9
Rating Plate.....	9
Inlet Gas Line Sizing.....	9-10
<b>PRE-INSTALLATION</b>	
General.....	11
Standards.....	11
Air Supply and Ventilation.....	11
<b>RECEIVING AND INSTALLING</b>	
Unpacking.....	14
Installing.....	14
Leveling.....	14
Gas Connection.....	15
Electrical Connection.....	15
<b>ULTRASTAT 23</b>	
Computer Panel Key Descriptions.....	16-17
Programming Guide.....	18
Start-up and Cooking Operation.....	19-21
<b>PREVENTIVE MAINTENANCE AND TROUBLESHOOTING</b>	
Preventive Maintenance.....	23
Troubleshooting.....	24
Troubleshooting Chart.....	24-25
<b>CLEANING</b>	
Daily.....	27
Weekly.....	27
<b>TECHNICAL ASSISTANCE &amp; ORDERING INFORMATION</b>	
Technical Assistance.....	28
Ordering Information.....	28
<b>RECOMMENDED SPARE PARTS</b>	
Spare Parts Listing.....	31
<b>PARTS IDENTIFICATON</b>	
Parts Identification.....	33-36
<b>SERVICE PROCEDURE AND ADJUSTMENTS</b>	
Harmonic Tone.....	38
Gas Valve.....	38
Infrared Burner Spark Ignitor and Temperature Probe Settings.....	39
Ground Wire Connection.....	39
Premix Gas Blower (PWM) Settings.....	40
Delay On Make Settings.....	40
Temperature Probe Settings.....	41
Hi Limit Probe Settings.....	41
<b>LADDER / SCHEMATIC DIAGRAM</b>	
Ladder Diagram.....	43
Schematic Diagram.....	44

**GENERAL INFORMATION**

## A. WARRANTY



### ULTRAFRYER® LIMITED WARRANTY PAR-3 GAS, ELECTRIC

Ultrafryer Systems warrants to the original purchaser of a gas or electric Ultrafryer® sold within the United States, its territories and Canada, that it will be free of defects in material and workmanship for the periods listed below:

**STAINLESS STEEL FRYER VAT** – Stainless Steel fryer vats are warranted for (10) ten years upon the terms hereinafter described. The (10) ten year warranty coverage applies ONLY to the Stainless Steel fryer vat and does not apply to the other components such as controls, fire boxes, gaskets, mounting hardware, or the heat shield weldment. The (10) ten year limited warranty coverage for the Stainless Steel fryer vats are as follows: (1) Vats that fail due to faulty workmanship or materials within the first twelve (12) months from the date of initial start up will be exchanged at no cost. Standard delivery ground freight will be prepaid by Ultrafryer Systems for first year failures only. The cost of labor to install the replacement vat will be covered by Ultrafryer Systems for vats, which fail within twelve (12) months from the date of initial start up. Labor for vat replacements after the first year is the responsibility of the owner.

(2) Vats that fail within the second year will be exchanged at \$150.00 FOB San Antonio. (3) Vats that fail within the third through fifth year will be exchanged at \$200.00 FOB San Antonio. (4) Vats that fail within the sixth through eighth year will be exchanged at 50% of current selling price of said vat FOB San Antonio. (5) Vats that fail within the ninth through tenth year will be exchanged at 70% of the current selling price of said vat FOB San Antonio. (Example: If the current selling price for a particular vat is \$1000.00, then a failure during the sixth through eighth year would be exchanged for \$500.00; if the failure occurred in the ninth or tenth year it would be exchanged for \$700.00.) Proper credit issue for vat failures is contingent upon receipt, by Ultrafryer Systems, of the serial number identification tag for any failed vat.

**ULTRAFRYER PARTS** – All parts on the Ultrafryer® are covered for a period of one (1) year from the initial date of start up. This is to include computers, gas valves, switches, thermostats, etc. Ultrafryer Systems reserves the right to charge for certain parts such as computers, filter pumps and motors or any item over the amount of \$100.00 until Ultrafryer Systems receives the defective part back. After inspection, credit for the part will be issued to the purchaser provided the part is deemed defective and that defect is not the result of neglect or abuse by the user. The shortening filtration system, (hoses) are warranted for ninety (90) days from the initial date of start up.

**PROCESSING WARRANTY CLAIMS** – The equipment owner must promptly notify Ultrafryer Systems Warranty Department of any alleged defects as soon as they are discovered by calling 1-800-525-8130. After such notice, the Warranty Department will perform its obligation under this warranty within a commercially reasonable period of time. If alleged defects develop after normal business hours, on weekends or on holidays the owner must call Ultrafryer Systems first at the above number. This number is monitored 24 hours a day, 7 days a week. Ultrafryer Systems will notify an authorized service agent to make repairs during normal hours or after hours. Any parts that need to be shipped back to Ultrafryer Systems will be shipped back prepaid by the customer marked with the processing number and to the attention of the WARRANTY DEPARTMENT.

**NON WARRANTY COVERAGE** – This warranty does not include coverage for any consequential cost of damages including, but not limited to, any loss in store sales, spoiled food products, transportation, duty or custom cost. This warranty does not cover the Ultrafryer® exported to countries outside the United States and its territories. This warranty does not cover original installation and adjustments such as leveling, calibrations and electrical and gas connections. This warranty does not cover travel over 100 miles or 2 hours driving time from the location of the Ultrafryer® or overtime or holiday charges unless the Warranty Department granted prior approval. This warranty does not cover damage due to misuse, abuse, alteration or accident. This Warranty does not cover improper or unauthorized repair or installation, damage in shipment, normal maintenance items such as gaskets, hoses, and exterior finishes. Ultrafryer Systems reserves the right to void component part warranty on any Ultrafryer that is stored more than six (6) months after shipment from Ultrafryer Systems and not put into service.

**LABOR COVERAGE** – The cost for labor to replace parts are covered for one (1) year after the initial start up. This warranty will include the labor involved in the twelve (12) month fryer inspection recommended by the manufacturer for the first year after initial startup. The Warranty Department must be promptly notified of any defects within the first year of operation. The labor warranty does not include the cost to repair or clear dirty filter systems or perform any adjustments that would normally fall under the tasks associated with a proper start up and/or demonstration. Labor is covered by Ultrafryer Systems for repairs by an AUTHORIZED service agent. Owner is responsible for all costs associated with fryer installation and start up unless prior arrangements have been made with Ultrafryer Systems.

#### DISCLAIMER OF WARRANTIES

Other than as stated herein, ULTRAFRYER SYSTEMS makes no warranty of any kind, express or implied, including but not limited to any warranty of merchantability of fitness for a particular purpose, including trade usage. Ultrafryer Systems' sole obligation, and purchaser's sole remedy, under this warranty is repair or replacement, at the discretion of Ultrafryer Systems, of any part or component that proves to be defective in materials or workmanship. In no event shall Ultrafryer Systems be liable for consequential, incidental, or special loss or damages arising from the use of, or inability to use, the ULTRAFRYER®. This limited warranty is the only and complete statement with respect to warranties of NEW Ultrafryer® PAR-3 Gas and Electric ULTRAFRYERS® sold after June 1st, 2000. There are no other documents or oral statements for which Ultrafryer Systems will be responsible.

## **B. SAFETY**

The major safety concern associated with the Ultrafryer Premix Gas fryer is burns from hot shortening. In order to prevent serious burns, good housekeeping habits are required. The floor in front of and the area around the fryer should be kept clean and dry. Whenever anything is placed into a fryer vat, care should be used not to splash the hot shortening. Product should always be "PLACED" into the shortening, not thrown. Safety goggles, neoprene insulated gloves, and an apron must be worn while boiling-out a fryer vat. Electrical controls used in the gas fryer operate on 120 volts single phase electrical power, and no adjustments or replacement of electrical controls should ever be attempted without first disconnecting electrical power. The fryer should never be operated with wet hands or while standing in water. To do so can result in serious electrical shock or death.

## **C. DESCRIPTION**



**ULTRAFRYER ID 20x17 PREMIX GAS FRYER**

The Ultrafryer 20"x17" (508mm x 432mm) ID premix gas fryer was designed by Ultrafryer Systems® to operate as an energy-efficient, gas-fired fryer and is design-certified by the Canadian Standards Association (CSA) and the National Sanitation Foundation (NSF). It is manufactured to operate on either NATURAL or PROPANE gas according to the following Operational Requirements. Each fryer is shipped completely assembled with the accessories packed inside the fryer vat, and each fryer has been adjusted, tested and inspected prior to shipment. This gas fryer is designed to be used in a commercial food preparation environment after it is properly installed as outlined in this manual.

**D. SPECIFICATIONS**

**MODEL 20"x17" (508mm x 432mm) ID PREMIX GAS FRYER  
OPERATIONAL REQUIREMENTS**

<u>SPECIFICATION ITEM</u>	<b>20"x17" ID</b>
Overall Width	21.375" (543mm)
Overall Depth	33.49" (850mm)
Work Height	34.95" (888mm)
Oil Capacity High Level Low Level	100 lbs (45.4 liters) 78 lbs (35.8 liters)
Vat Container Size	20.00" x 17.375" (508mm x 441mm)
Gas Pressure (inlet to fryer) Natural Gas Propane	7" (178mm) W.C. 14" (356mm) W.C.
Gas Rating Natural Gas Propane	150,000 BTU/hr (158.15 MJ/hr) 150,000 BTU/hr (158.15 MJ/hr)
Shipping Cube	29" x 42" x 45" (74mm x 107mm x 114mm)
Shipping Weight	412 lbs (186.9 kgs)
Power Input	120 Volt, 15 Amp, 60Hz, 1 Phase

**FT<sup>3</sup> / HR (M<sup>3</sup> / HR) VALUES May vary due to heating value and specific gravity of gas supplied by local Gas Company**

**NOTE:**

**Test Start-Up, Operation, Cooking, Filtering and Boil Out Procedures of a 20"x17" Model ID Premix Gas Fryer in the manual are based on the Ultrastat 23 Cooking Computer.**

**Refer to Manual P/N 30A216 to perform these functions in a fryer equipped with this controller.**

**E. OPERATING CONTROLS**

The fryer is equipped with an Ultrastat 23 Cooking Computer as shown on the next page. Operating instructions for the Ultrastat 23 Cooking Computer (P/N 30A216) will be provided with the fryer. Operating controls on the fryer include the Ultrastat 23 Cooking Computer and the Red Heating Indicator Lamp, these controls are mounted on the Controller Door. The Temperature Probe and Hi-Limit Switch, these controls are located inside the vat. The Drain Ball Valve and Red Hi-Limit Reset Switch, these controls are located behind the Service Access Door. These controls were identified in the illustrations shown on the next page.

**F. OPERATING CONTROLS LOCATION**

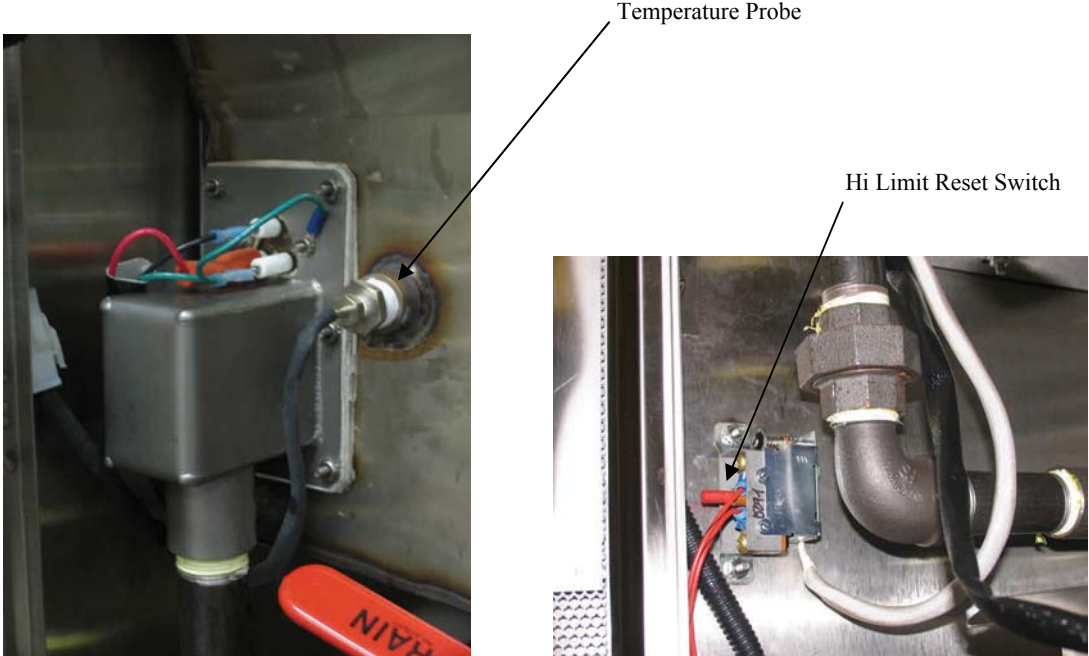
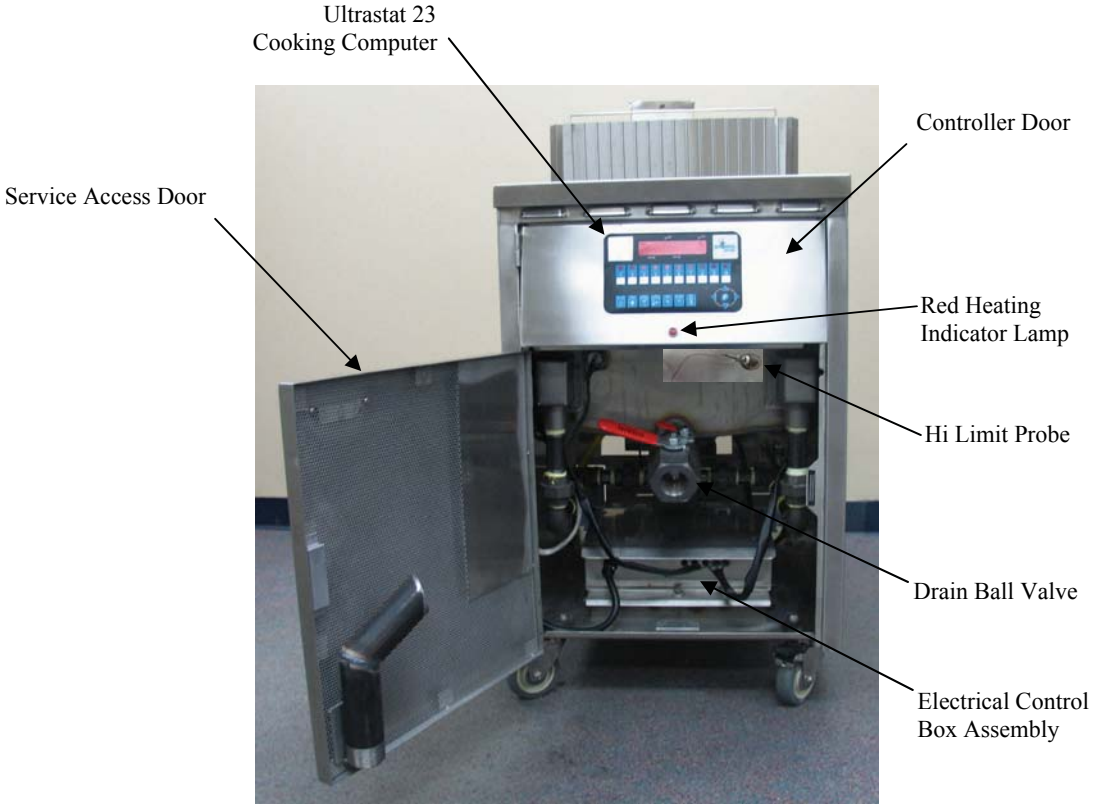

## G. AUTOMATIC SAFTEY FEATURES

1. High Limit thermostat to shut off gas to the main burners by opening a solenoid –activated safety valve in the combination gas control valve.
2. Combination gas control valve which includes a built-in pressure regulator.
3. Air pressure switch to open the 24 volt electrical circuit to the gas control valve, which turns off the gas to the fryer OFF if a Blower Motor becomes inoperable.
4. Sensing Circuit within the spark ignitor module to which turns gas to the fryer OFF if a burner FLAME OUT occurs.
5. A Current Sensor and Air Pressure Switch which, combined, provide an air Proof System for the fryer.

## H. RATING PLATE

The Rating Plate is located on the inside of the Service Access door and contains the following information: the model and serial numbers, BTU/HR input rating of the burners, gas manifold pressure in inches W.C. , minimum inlet gas required, and gas type. This data is essential for proper identification when communicating with ULTRAFRYER SYSTEMS or requesting special parts or information.

### DANGER:

**THE FRYER MUST BE CONNECTED ONLY TO THE TYPE OF GAS IDENTIFICATION ON THE RATING PLATE !**

## I. INLET GAS LINE SIZING

The table below is to be utilized to calculate the size (diameter) of the inlet gas line from the building regulator to the fryer manifold.

INLET GAS LINE REQUIREMENTS									
PIPE LENGTH Feet (Meters)	PIPE DIAMETERS (inches & mm equivalents) Maximum Allowable Flow (Shown in ft <sup>3</sup> /hr (M <sup>3</sup> /hr))								
	1/2" (13 mm)	1/2" (19mm)	1" (25mm)	1 1/4" (32mm)	1 1/2" (38mm)	2" (51mm)	2 1/2" (64 mm)	3" (76mm)	4" (102mm)
15 (4.6)	62 (1.7)	170 (4.7)	350 (9.8)	620 (17.4)	960 (26.9)	2,000 (56.0)	3,500 (98.0)	5,400 (151.2)	11,200 (313.6)
30 (9.1)	43 (1.2)	120 (3.4)	245 (6.9)	430 (12.0)	680 (19.0)	1,400 (39.2)	2,450 (68.6)	3,800 (106.4)	7,900 (221.2)
45 (13.7)	35 (1.0)	98 (2.7)	200 (5.6)	355 (9.9)	530 (14.8)	1,150 (32.2)	2,000 (56.0)	3,200 (89.6)	7,900 (182.0)
60 (18.3)	30 (0.8)	84 (2.4)	175 (4.9)	310 (8.7)	480 (13.4)	1,000 (28.0)	1,760 (49.3)	2,700 (75.6)	5,600 (156.8)
75 (22.9)	27 (0.8)	76 (2.1)	155 (4.3)	275 (7.7)	430 (12.0)	890 (24.9)	1,560 (43.7)	2,450 (68.6)	5,000 (140.0)
90 (27.4)	25 (0.7)	70 (2.0)	145 (4.1)	250 (7.0)	395 (11.1)	810 (22.7)	1,430 (40.0)	2,260 (63.3)	4,550 (127.4)
105 (32.0)	23 (0.6)	64 (1.8)	132 (3.7)	232 (6.5)	370 (10.4)	750 (21.0)	1,300 (36.4)	2,100 (58.8)	4,200 (117.6)
120 (36.6)	21 (0.6)	60 (1*7)	125 (3.5)	215 (6.0)	340 (9.5)	700 (19.6)	1,200 (33.6)	1,950 (54.6)	4,000 (112.0)
150 (45.7)	19 (0.5)	54 (1.5)	no (3.1)	195 (5.5)	310 (8.7)	630 (17.6)	1,080 (30.2)	1,750 (49.0)	3,550 (99.4)
180 (54.9)	17 (0.5)	49 (1.4)	100 (2.8)	175 (4.9)	280 (7.8)	570 (16.0)	960 (26.9)	1,600 (44.8)	3,200 (89.6)
210 (64.0)	16 (0.4)	44 (1.2)	94 (2.6)	165 (4.6)	260 (7.3)	530 (14.8)	890 (24.9)	1,450 (40.6)	3,000 (84.0)
240 (73.2)	15 (0.4)	43 (1.2)	88 (2.5)	155 (4.3)	240 (6.7)	500 (14.0)	840 (23.5)	1,350 (37.8)	2,800 (78.4)
270 (82.3)	14 (0.4)	40 (1.1)	83 (2.3)	145 (4.1)	230 (6.4)	470 (13.2)	780 (21.8)	1,300 (36.4)	2,650 (74.2)
300 (91.4)	14 (0.4)	38 (1.1)	79 (2.2)	138 (3.9)	215 (6.0)	440 (12.3)	750 (21.0)	1,250 (35.0)	2,500 (70.0)
450 (137.2)	11 (0.3)	31 (0.9)	64 (1.8)	112 (3.1)	176 (4.9)	360 (10.1)	630 (17.6)	1,000 (28.0)	2,050 (57.4)
600 (182.9)	10 (0.3)	27 (0.8)	56 (1.6)	97 (2.7)	152 (4.3)	315 (8.8)	530 (14.8)	860 (24.1)	1,750 (49.0)

NOTE: 1) FT<sup>3</sup>/HR (M<sup>3</sup>/HR) values may vary due to heating value and specific gravity of gas supplied by local companies.

2) To determine the inlet gas line diameter for the distance between the fryer and main gas regulator, locate the FT<sup>3</sup>/HR (M<sup>3</sup>/HR) of gas required for the fryer and pipe length and read the pipe diameter on the top row. For example, a 14" PD fryer operating on NATURAL GAS requires 105 FT<sup>3</sup>/HR (3.0 M<sup>3</sup>/HR) of gas at the fryer's inlet gas manifold. If the fryer bank is located 60 feet from the building gas regulator, a 1" (25mm) diameter gas line MUST be installed between the manifold and regulator.

**J. FLEXIBLE GAS LINE LENGTHS**

The Flexible Gas Line used to connect the gas manifold to the building gas supply line must be rated for the BTU/Hr (MJ/Hr) designated for the Fryer. Flexible gas lines and their ratings stocked by Ultrafryer Systems are listed below:

FLEXIBLE GAS LINES STOCKED BY ULTRAFRYER SYSTEMS		
NUMBER	DESCRIPTION	RATING BTU/HR (MJ/HR)
24322	3/4" (19mm) Diameter Flexible Gas Line (w/quick connect couplings) 48" (1219mm) long. Connect-It SSGC75-48-UCQ	225,000 (238)
24323	1" (25mm) Diameter Flexible Gas Line (w/quick connect couplings) 48" (1219mm) long. Connect-It SSGC100-48-UCQ	435,000 (459)
24456	1 1/2" (32mm) Diameter Flexible Gas Line (w/quick connect couplings) 48" (1219mm) long. Connect-It SSGC125-48-UCQ	875,000 (924)

## **PRE-INSTALLATION**

#### **A. GENERAL:**

Safe and satisfactory operation of a Model F-ID 20x17 premix gas fryer depends on its proper installation. Installation must conform to local codes or, in the absence of local codes, with the current National Fuel Gas Code ANSI Z223.1/NFPA 54 (latest edition). In Canada, gas installation shall be in accordance with the current CSA B 149.1 and .2 installation codes and/or local codes. Each Model F-ID 20x17 premix gas fryer should be installed as follows:

1. Placed beneath a properly designed exhaust hood
2. Installed by a licensed plumber.
3. Connected to the type gas for which the unit was fabricated as shown on the rating plate.
4. Connected to the proper size pressure regulator installed in the gas supply line and adjusted to the proper manifold pressure.
5. Connected to the main gas supply line with the proper size supply line.
6. Restrained by use of a restraining device to avoid splashing of hot liquid and to assure tension cannot be placed on the flexible gas line or fittings. **CLEARANCES:** The appliance must be kept free and clear of all combustibles. The minimum clearance from combustible and non-combustible construction is 6" (152 mm) from the sides, and 6" (152 mm) from rear. The fryer may be installed on combustible floors.

**NOTE:** Adequate clearances must be provided for servicing and proper operation.

**B. STANDARDS:** Installation must be planned in accordance with all applicable state and local codes, taking into account the following standards:

1. The fryer and its individual shut-off valve must be disconnected from the gas supply piping system during any pressure testing of that system at pressures in excess of 1/2 psi (3.45kPa). In Canada, gas installation shall be in accordance with the current CSA B 149.1 and .2 installation codes and/or local codes.
2. The fryer must be isolated from the gas supply piping system by closing its individual manual shut-off valve during any pressure testing of the gas supply piping system at pressures equal to or less than 1/2 psig (3.45kPa).
3. When installed the fryer must be electrically grounded in accordance with local codes, or in the absence of local codes, in accordance with the current National Electrical code ANSI/NFPA 70 (latest edition). In Canada electrical installation must be in accordance with the current CSA C22.1 Canadian Electrical Code and/or local codes.
4. Other applicable nationally recognized installation standards such as:
  - a. National Fuel Gas Code ANSI Z223.1/NFPA 54 (latest edition)  
American Gas Association  
1515 Wilson Blvd.  
Arlington, VA 22209
  - b. NFPA Standards #54, #94 and #221 (latest edition)  
National Fire Protection Association  
470 Atlantic Avenue  
Boston, MA 02110
  - c. ANSI Z21.69/CSA-6.16 AND ANSI Z21.41/CSA 6.9
5. Exhaust vent hood, when installed must conform to the current NFPA 54-1 and Canadian Standards (latest edition).

**NOTE:** Local building codes will usually not permit a fryer with its open tank of hot oil to be installed immediately next to an open flame of any type, whether a broiler or an open burner or range. Check local codes before beginning installation.

**C. AIR SUPPLY AND VENTILATION:** The area around the appliance must be kept clear of any combustible or flammable products and avoid any obstruction to the flow of ventilation air as well as for ease of maintenance and service. **NOTHING** is to be stored in the interior of the fryer's cabinet.

1. A means must be provided for any commercial, heavy duty-cooking appliance to exhaust combustion wastes outside of the building. It is essential that a fryer be set under a powered exhaust vent hood or that an exhaust fan be provided in the wall above the unit, as exhaust temperatures are in the vicinity of 400°F (204°C).

**NOTE:** Strong exhaust fans in a hood or in the overall air conditioning system can produce slight air drafts in the room, which can interfere with burner performance and be hard to diagnose. Air movement should be checked during installation and if burner problems persist, make-up air openings or baffles may have to be provided in the room.

2. Exhaust temperature, in addition to the open tank of hot oil, make the storage of anything on shelving over or behind the fryer unsafe.
3. Filters and drip troughs should be part of any industrial hood, but consult local codes before constructing and installing any hood.
4. Provisions must be made for an adequate supply of fresh air and adequate clearance must be maintained for air openings into the combustion chamber.

## **RECEIVING AND INSTALLING**

- A. UNPACKING:** Check that the container is upright. Use an outward prying motion – **DO NOT USE A HAMMER** - to remove the carton. Check the fryer for visible damage; if such damage has occurred do not refuse shipment, but contact the carrier and file the appropriate freight claims.
- B. INSTALLING:** Roll the assembled fryer into the building, to its operating location.

**WARNING: IMPROPER INSTALLATION, ADJUSTMENT, ALTERATION, SERVICE, OR MAINTENANCE CAN CAUSE PROPERTY DAMAGE, INJURY, OR DEATH. READ THE INSTALLATION, OPERATING AND MAINTENANCE INSTRUCTIONS THOROUGHLY BEFORE INSTALLING OR SERVICING THIS EQUIPMENT.**

**C. LEVELING:**

- When the fryer is placed in its operating location, check to be sure it is level. If not, loosen the casters and insert the appropriate number of shim plates between leg and caster plates then retighten the caster bolts.
- If the floor is smooth and level, adjust to the high corner and measure with a spirit level. If the floor is uneven or has a decided slope, level the unit with metal shims.

**NOTE:** A caster may not return exactly to the same position after being moved, which may require re-leveling after each move.

- Connect the gas manifold to the building gas supply line by means of a CSA Group APPROVED flexible gas line as shown in the figure below.

**NOTE:** CONNECT-IT Inc. 3/4" (19mm), 1" (25mm) and 1 1/4" (32mm) flexible gas hose 4 feet long (1219mm) with a quick disconnect coupling on one end is available from Ultrafryer Systems under PN 24322 (3/4" (19mm) hose), PN 24323 (1" (25mm) hose) and PN 24456 (1 1/4" (32mm) hose). These hoses are equipped with a fusible link, which melts at 361°F (183°C) that will **SHUT OFF** the gas supply when it melts. Reference Installation Instructions sheet provided with hose for additional information. A 44" (1119mm) long restraining device is also available under PN 24324. Install as shown below between the wall and the fryer using existing mounted hardware or add hardware to the wall and fryer making a secure connection at each ends.

**CAUTION: THE BUILDING GAS SUPPLY LINE MUST BE SIZED TO PROVIDE THE VOLUME OF GAS REQUIRED FOR PROPER OPERATION AS EXPLAINED ON THE PREVIOUS PAGE.**

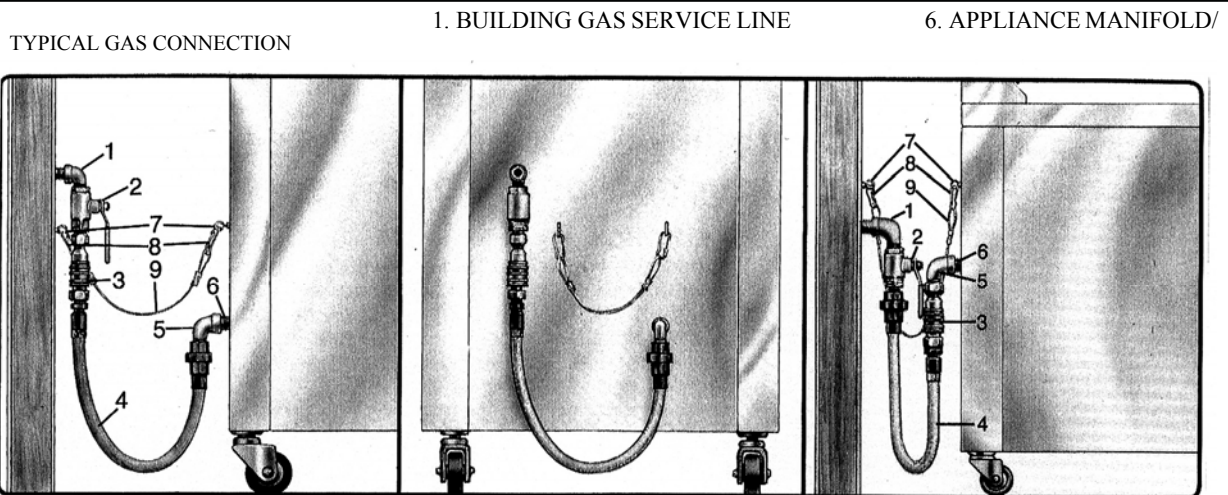

**WARNING: THE RESTRAINT DEVICE (ITEM 9) MUST BE INSTALLED TO ASSURE TENSION CANNOT BE PLACED ON THE FLEXIBLE GAS LINE OR FITTING.**

- |                                |        |                      |
|--------------------------------|--------|----------------------|
|                                | NIPPLE |                      |
| 2. MAIN GAS CUT-OFF VALVE      |        | 7. EYELET FASTENERS  |
| 3. CONNECT-IT QUICK-DISCONNECT |        | 8. SPRING HOOK       |
| 4. FLEX-CON CONNECTOR          |        | 9. RESTRAINING CHAIN |
| 5. ELBOW                       |        |                      |

**D. GAS CONNECTION:** The gas supply (service) line must be the same size or greater than the inlet line of the appliance. **THE GAS SUPPLY LINES MUST BE SIZED TO ACCOMMODATE ALL THE GAS FIRED EQUIPMENT THAT MAY BE CONNECTED TO THAT SUPPLY.** Refer to the Inlet Gas Line Sizing Table and inlet gas requirements.

**NOTE:** Sealant used on all pipe joints must be resistive to natural and propane gas.

1. Manual shut off valve: This supplier-installed valve must be installed in the gas service line ahead of the appliance and in a position where it can be reached quickly in the event of an emergency.
2. Pressure regulator: All commercial cooking equipment must have a pressure regulator on the incoming service line for safe and efficient operation, because service pressure may fluctuate with local demand. External regulators are not required on this fryer, as that function is performed by a combination gas control valve, however if the incoming pressure is in excess of 1/2 psig, a step-down regulator will be required.
3. Natural gas: Natural gas fryers require 7" (178mm) water column (W.C.) "inlet" pressure to the fryer's combination gas control valve for proper operation, when all gas units are operating simultaneously. Propane gas fryers require 14" (356 mm) water column (W.C.) "inlet" pressure to the fryer's combination gas control valve for proper operation, when all gas units are operating simultaneously. This "inlet" pressure **MUST** be checked with a manometer **PRIOR** to

**WARNING: IF THE "INLET" GAS PRESSURE AT THE FRYER'S COMBINATION GAS CONTROL VALVE "EXCEEDS" 1/2 lb/in2 (.035 kg/cm2) OR APPROXIMATELY 11" (280mm) W.C., AN EXTERNAL REGULATOR MAY BE NEEDED TO PREVENT DAMAGE TO THE COMBINATION GAS VALVE AND VOIDING OF WARRANTY. FAILURE TO ADDRESS THIS COULD RESULT IN AN EXPLOSION OR A FIRE.**

placing the fryer in operation.

4. Combination gas control valve: The correct combination gas control valve and orifice is installed at the factory for **NATURAL** and **PROPANE** units based on each Purchase Order. This valve should be **CHECKED/ADJUSTED** by qualified service personnel using proper test equipment for the following "**OUTLET**" gas pressure **PRIOR** to start-up of a fryer. **NATURAL GAS FRYERS 7" (178mm) W.C. PROPANE FRYERS 14" (356mm) W.C.**
5. Rigid connections: Check any installer-supplied intake pipe(s) visually and/or blow them out with compressed air to clear dirt particles, threading chips or any other foreign matter before connecting to the service line as these particles may clog the orifice when gas pressure is applied. All connections must be tested with a soapy solution before lighting the fryer. **DO NOT USE AN OPEN FLAME TO CHECK FOR LEAKS!** Putting an open flame beside a new connection is not only dangerous, but will often miss small leaks that a soapy solution would find.
6. Flexible Couplings and Connectors: The installation is to be made with a connector that (1) complies with the **Standard for Connectors for Movable Gas Appliances, ANSI Z21.69 (CSA 6.16)**, and a quick-disconnect device that complies with the **Standard for Quick-Disconnect Devices for Use With Gas Fuel, ANSI Z21.41 (CSA 6.9)** (2) adequate means must be provided to limit the movement of the appliance without depending on the connector and the quick disconnect device or its associated piping to limit the appliance movement and (3) the location(s) where the restraining means may be attached to the appliance shall be specified. **DOMESTIC CONNECTORS ARE NOT SUITABLE!!!**
7. Fryer Service: The fryer is equipped with swivel casters. To service the fryer:
  - a) Remove / unplug power supply from fryer
  - b) Turn "OFF" gas supply at the supply source.
  - b) Disconnect the flexible gas line quick-disconnect
  - c) Disconnect restraint means and roll fryer out for rear service access.
  - d) When the fryer is re-positioned, be sure to reconnect the restraint and level the fryer.

**E.ELECTRICAL CONNECTION:** The MAXIMUM current draw per vat at Initial Start-up or during a Warm-up Cycle will be 3 Amperes at 120 Volts. When running the Filter System simultaneously allow for an additional 3 Amperes. Refer to the wiring diagram attached to the inside of the Service Access door for internal electrical connections.

**WARNING: (ELECTRICAL GROUNDING INSTRUCTIONS)**  
**THIS APPLIANCE IS EQUIPPED WITH A THREE-PRONG (GROUNDING) PLUG FOR YOUR PROTECTION AGAINST SHOCK HAZARD AND SHOULD BE PLUGGED DIRECTLY INTO A PROPERLY GROUNDED THREE-PRONG RECEPTACLE. DO NOT CUT, REMOVE, OR OTHERWISE BYPASS THE GROUNDING PRONG ON THIS PLUG!**

### F. Ultrastat 23 Cooking Computer

The Ultrastat 23 Cooking Computer is a high performance, microprocessor-based electronic controller designed for use in commercial appliance temperature and timing control applications. Utilizing a microcontroller board, membrane switch front panel with a digital LED readout and display board, the Ultrastat 23 Cooking Computer has been customized for Ultrafryer Systems applications by the addition of up to 10 stage cooking profiles for each of the 10 product keys; features can be programmed to cook products under “Flex” or “Straight” timing modes. Operation of the Ultrastat 23 Cooking Computer is covered in its Instruction Manual PN 30A216 provided with the Fryer.

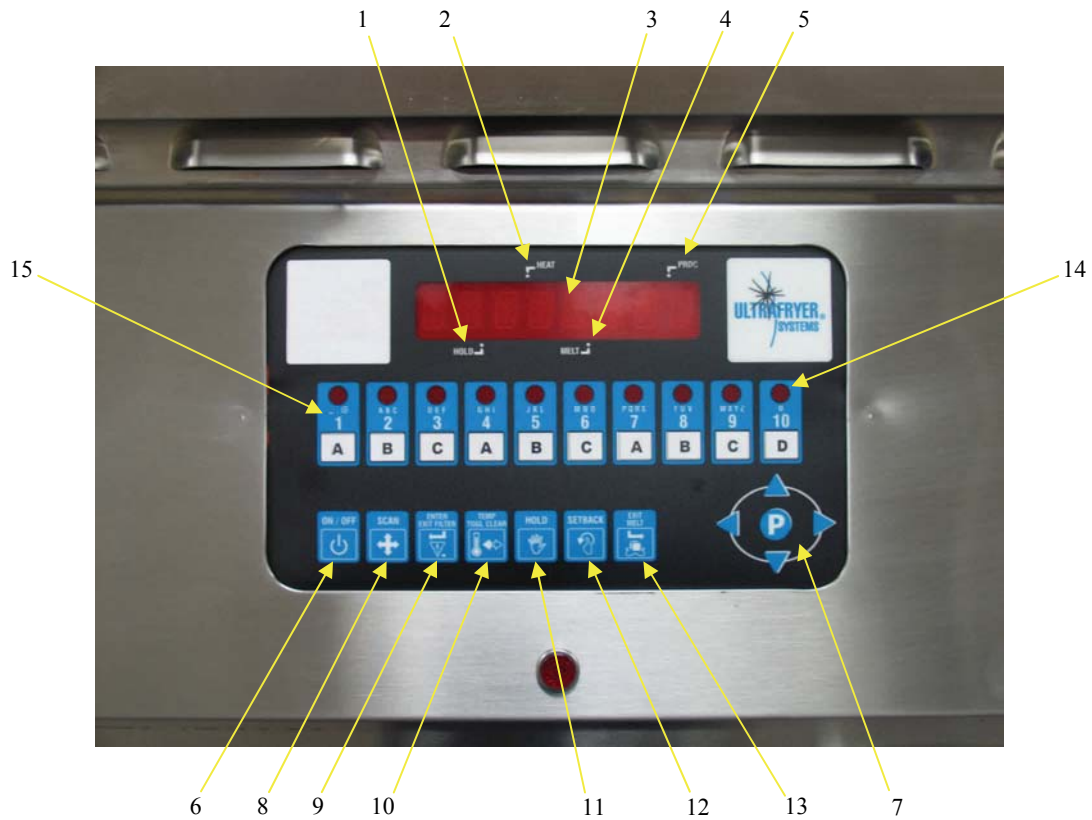



## COMPUTER PANEL KEY DESCRIPTIONS

1. HOLD LAMP  
When lit (bright) indicates a product hold time is being tracked.
2. HEAT LAMP  
When lit (bright) indicates the computer is calling for heat.
3. DISPLAY  
Displays modes, functions and operations of the computer.
4. MELT LAMP  
When lit (bright) indicates the computer is in the melt cycle.
5. PROGRAM LAMP  
When lit (bright) indicates the computer is in the program mode.
6. ON/OFF KEY  
Turns the computer ON and OFF when the fryer power switch is in the ON position and the drain valve lever is in the closed UP position.
7. PROGRAM KEY
  - a. In “operating” mode, allows access to the programming mode.
  - b. In “programming” mode, allows access to the operating mode and general navigation function.
8. SCAN KEY
  - a. In “operating” mode, displays the remaining cook time on every product currently in a cook cycle and lights the respective products “LED” for 2 seconds.
  - b. In “programming” mode, steps to the next function to be programmed.
9. ENTER EXIT FILTER KEY  
This key will force the fryer into the filter mode. This key is an optional feature.
10. TEMP/TOGGLE CLEAR KEY
  - a. In “operating” mode, displays the actual temperature followed by the programmed “set” temperature.
  - b. In “programming” mode, will “clear” values from a data field.
11. HOLD KEY
  - a. In “operating” mode, used to view remaining hold times.
12. SET BACK
  - a. In operating mode forces setback . Display will show “setback” and appliance will be controlled to **setback** temperature instead of **set point** temperature.
13. EXIT/MELT KEY
  - a. In “operating” mode, used to manually exit the shortening melt cycle.
14. PRODUCT LED
  - a. When lit (bright) in the “operating” mode, identifies the product data being displayed.
  - b. When lit (bright) in the “programming” mode, identifies the product being programmed.
15. PROGRAMMING AND PRODUCT COOK KEY
  - a. In “operating” mode, used to start and stop a product’s cook cycle.
  - b. In “programming” mode, used to enter numerical values 1 to 10.

# Ultrastat 23 Programming Guide

- 1** Turn Toggle ON/OFF switch to ON position and amber power indicator lamp will illuminate.  
Then press power ON/OFF key.



- 2** Push and hold the "P" key for 3 seconds to enter PROGRAMMING MODE. PROGRAM will appear in display.



- 3** Push "P" key the second time to display CODE. Enter "1724" and push the "P" key. RECIPE will display.



- 4** Push "P" key and "PRODUCT" will display. Hit product key you want to program and hit "P" key.



- 5** Display shows "ALL". Push "P" key to program each function and "NAME" appears. To change hit the "DOWN ARROW" and scroll to find the word you want in the library. Then push the "P" key to enter it and go to the next item.



- 6** "TIME 1" will display. To change the time hit "TOGGLE CLEAR" index the time you want on the number pad and press the "P" key to save.



- 7** "TEMP 1" will display. To change hit "TOGGLE CLEAR" and key in the amount you want and hit the "P" key.



- 8** "FLEX" or "STRAIGHT" time will appear. To change from one to the other, hit the left arrow key. Then hit the "P" key to save it.



- 9** Display shows "TIME 2". Repeat steps 6, 7, and 8 for each profile. After the last profile, display will show "ALARM TIME 1".

- 10** To change "ALARM TIME 1" hit "TOGGLE CLEAR" and index what you want on the number keys and hit the "P" key and the display will show "ALARM NAME".

- 11** To change "ALARM NAME" hit "DOWN ARROW" and scroll until you find the name you want. Then hit the "P" key. Repeat for alarm 2 and 3 if applicable.

- 12** Display will show "HOLD TIME 1". For most applications this is not used so exit at this point. To exit press the "DOWN ARROW" key repeatedly until "EXIT" shows on the display. Then hit the "P" key. "PRC DUCT" will show on the display.

- 13** Then hit the "UP ARROW" key and display will show "EXIT". Hit the "P" key and display shows "RECIPE". Hit the "UP ARROW" again then hit "P" key and "PREHEAT" or "READY" should appear. You are now out of program mode and ready to operate with the latest changes.



## ULTRASTAT 23 START-UP AND COOKING COMPUTER OPERATION

### NOTICE:

- 1) The computer will keep the fryer in the MELT CYCLE until the EXIT MELT button is manually depressed.
- 2) The computer CANNOT be taken out of the SHORTENING MELT MODE until the shortening temperature reaches the MELT LIMIT TEMPERATURE. The Melt Limit Temperature is factory set for a HIGH exit temperature (135°F / 57°C) or a LOW exit temperature (100°F/38°C).

The following are abbreviated operating procedures for a fryer equipped with an Ultrastat 23 Cooking Computer. The attached Ultrastat 23 Ultrafryer Computer Operating Instructions, Manual PN 30A216, contains DETAILED Operating, Filtering, Boil-Out, and Programming Instructions.

### START-UP and COOKING

ULTRASTAT 23 START-UP - Safely start-up an gas fryer equipped with an Ultrastat 23 Cooking computer as follows:

<u>STEP</u>	<u>ACTION</u>	<u>RESPONSE</u>
1	ENSURE the drain valve lever on the fryer is in the CLOSED position, shortening is at the proper level, then turn the computer ON by depressing the computer ON/OFF button.	A. The fryer heat exchanger will power up and begin to heat the shortening.

### CAUTION:

**PRIOR TO PROCEEDING TO NEXT STEP, VISUALLY CHECK THAT THE HEAT EXCHANGER IS COVERED WITH AT LEAST 2” (51mm) OF SHORTENING**

2	Turn the Computer ON by depressing the computer ON/OFF button.	A. The MELT lamp will LIGHT to indicate the computer is in the SHORTENING MELT MODE. B. The HEAT lamp on the computer and the RED heat mechanism indicator lamp on the fryer will cycle ON and OFF indicating the heat mechanism is periodically being turned ON and OFF to gen- tly heat the shortening.
3	Once the Melt Limit Temperature is reached depress the EXIT MELT BUT- TON on the computer to cancel the SHORTENING MELT MODE.	A. “HEATING” will appear in the computer display indicating shortening temperature is more than 10°F (5°C) below the set- point temperature. B. The HEAT lamp on the computer and the RED heat mechanism indicator lamp will remain ON until the set-point temperature is reached.
4	When “READY” appears in the Computer display indicating the SET-POINT TEM- PERATURE of the shortening has been reached, a COOK cycle can be initiated.	A. Stir the shortening several times to ensure that all the shortening has reached the set point temperature.

### ULTRASTAT 23 COOKING COMPUTER PROGRAMMING

Program the Ultrastat 23 Cooking Computer according to the Computer Operating Instructions Manual (PN 30A216) provided with the Fryer.

### NOTICE:

Programming of an Ultrastat 23 Cooking Computer should only be preformed by a store manager or area supervisor.

### **GENERAL COOKING**

Most products should be cooked with a shortening temperature about 350°F (177°C); however, each product should be cooked at the LOWEST temperature that produces a high quality product while obtaining maximum usage of the shortening.

#### **WARNING:**

- I – DO USE A HIGH QUALITY SHORTENING TO ACHIEVE A CONSISTENT QUALITY PRODUCT AND LONG TERM SAVINGS**
- II – DO NOT SALT PRODUCTS OVER THE FRYER AS SALT QUICKLY DETERIORATES THE SHORTENING AND FLAVORS OTHER PRODUCTS COOKED IN THE SAME SHORTENING**
- III – DO FILTER SHORTENING AFTER THE LUNCH AND DINNER RUSH AND MORE OFTEN IN A HIGH SALE VOLUME STORE; AND BOIL-OUT THE FRYER EVERY 7 DAYS**

#### **NOTICE:**

Startup steps 1, 2, 3, and 4 will have to be repeated each time any of the following occurs:  
DRAIN VALVE IS OPEN. FRYER ON/OFF SWITCH IS TURNED OFF TO FILTER SHORTENING OR BOIL-OUT A FRYER. FRYER ON/OFF SWITCH IS TURNED OFF AT CLOSING OR ANY OTHER REASON.

### **POWER FAILURE**

This fryer cannot be operated during power failures. **DO NOT** attempt to bypass safety and manually operate fryer.

#### **CAUTION:**

**THE FRYER HAS A RESTRAINT ATTACHED TO THE WALL TO LIMIT MOVEMENT AND TIPPING IN ORDER TO AVOID SPLASHING OF HOT LIQUID.**

**MOVING THE FRYER WITH HOT COOKING OIL IN THE VESSEL MAY CAUSE SPLASHING OF THE HOT LIQUID CAUSING SEVERE BURNS.**

**IF MOVING THE FRYER IS REQUIRED FOR CLEANING OR SERVICING. TAKE THE REQUIRED STEPS OF REMOVING THE RESTRAINT, POWER AND GAS CONNECTIONS BEFORE MOVING THE FRYER AND MAKE SURE THE COOKING OIL IN THE VESSEL IS COLD OR HAS BEEN REMOVED FROM THE VESSEL TO LIMIT ACCIDENTAL BURNS OR DAMAGE TO THE FRYER.**

When the Computer is taken out of the SHORTENING MELT MODE each morning, shortening in the fryer vat will be heated to its SETPOINT temperature, "HEATING" will appear in the display to indicate the shortening temperature is MORE than 20°F (-6.6°C) BELOW the set point temperature. When shortening temperature rises to the SETPOINT temperature, "READY" will appear in the display indicating a COOK CYCLE can be started.

### STARTING A COOK CYCLE

To start a cook cycle simply press the product key for the product you wish to cook. Cooking time will be displayed "3:00" (example) and this time will immediately start to count down in minutes and seconds. It will count down to ":00" followed by a beeping signal. To turn this signal OFF and reset the Computer, press the same product key used to start the COOK CYCLE.

### CANCELLING A COOK CYCLE

If a cook cycle was inadvertently started it may be cancelled two (2) ways:

- 1) Press and hold the same product key used to start the cook cycle for 4 SECONDS. This prevents an accidental start of a cook cycle while a product is being cooked.
- 2) A cook cycle can be CANCELLED at any time by turning the fryer ON/OFF Switch to the OFF position.

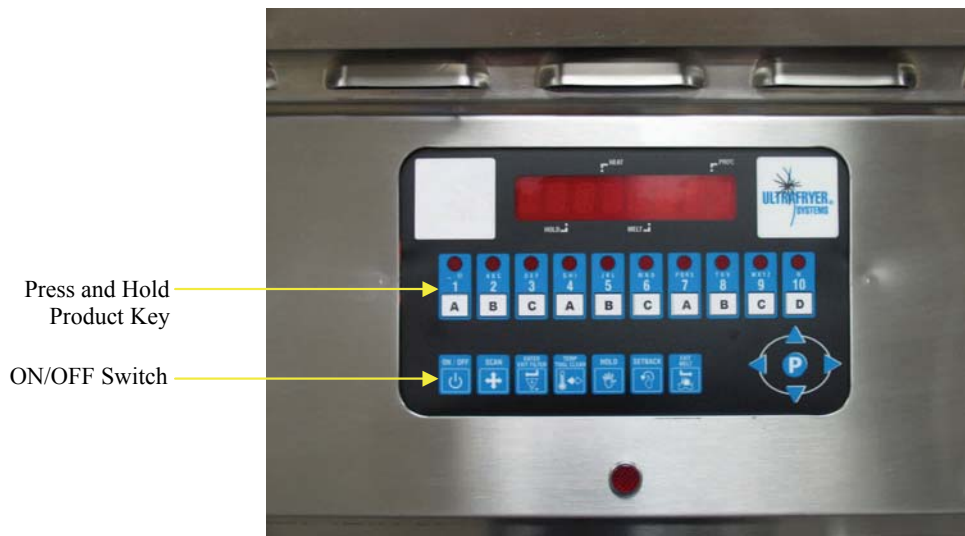

**PREVENTIVE MAINTENANCE AND TROUBLESHOOTING**

**PREVENTIVE MAINTENANCE**

Minimal maintenance is required on the fryer because of its design and materials used in the manufacturing process. However some preventive maintenance and inspection must be performed periodically to prevent breakdowns which could curtail food sales. Any preventive maintenance or inspection should be accomplished with **CAUTION** while the fryer is in operation since **HOT** liquid shortening could cause severe burns. If service or repairs are required, all electrical power and gas **MUST BE TURNED OFF PRIOR TO** performing that service or repair.

PREVENTIVE MAINTENANCE SCHEDULE

DAILY

ITEM

INSPECT FOR

Grease Filters

Clean grease filters in the exhaust vent hood every evening and allow them to dry overnight.

WEEKLY

ITEM

INSPECT FOR

Drain Valve Handle

Determine if the Drain Valve Handle is securely attached to the drain valve and that the valve can be easily opened and closed.

Temperature Sensing Probes

During boil-out of the fryer, inspect the temperature and hi limit sensing probes for any visible damage.

## TROUBLESHOOTING

**A. GENERAL:** The problems and possible solutions listed in the troubleshooting chart below are typical problems that are frequently encountered. **ONLY** qualified repairmen are to use the troubleshooting chart to repair this fryer. In the event a main burner malfunction occurs, perform the following checks **PRIOR** to contacting a repairman:

1. Check that the fryer electrical plug is connected to an electrical receptacle.
2. Ensure the applicable Circuit Breaker is in the **ON** position and that the fryer ON/OFF switch is in the **ON** position.
3. Ensure the applicable fryer control has been placed in the **EXIT MELT** mode.
4. Ensure the gas supply line quick-disconnect coupling is **SEATED** on the gas manifold fitting.
5. Determine that the blower is operating.

**B. TROUBLESHOOTING CHART:** Should a problem occur that cannot be corrected after performing the above CHECKS, contact an **AUTHORIZED** repairman and/or Ultrafryer Systems Customer Service 1-800-525-8130 and provide the information acquired while performing these checks.

<u>ITEM</u>	<u>PROBLEMS</u>	<u>POSSIBLE SOLUTIONS</u>
1	Ignition Lockout	1.) Harness connection to gas valve 2.) Gas valve or gas pressure 3.) All harness connections 4.) Electrode 5.) Interconnecting wiring malfunction 6.) Ignition module malfunction 8.) Grounding Status
2	No spark, No blower	1.) Harness connections 2.) Probe lead wires 3.) Open probe 4.) Controller
3	“Puffing” during normal start up	1.) Incorrect gas pressure 2.) Cracked electrode 3.) Electrode gap exceeded
4	Burner lights but will not maintain flame	1.) Igniter / flame sense misalignment 2.) Insufficient gas pressure
5	Excessive Heat	1.) Incorrect temperature offset selected 2.) Set Temperature exceeding 400 deg F 3.) Temperature probe malfunction 4.) Cooking control malfunction 5.) Interface board malfunction 6.) Gas pressure incorrect
6	Low heat	1.) Incorrect temperature offset selected 2.) Cooking control malfunction 3.) Temperature probe malfunction 4.) High limit tripped 5.) Interface board malfunction 6.) Gas pressure incorrect
7	Intermittent problems	1.) High ambient temperatures 2.) Wiring connections loose
8	No power to cooking control, fryer does not heat	1.) Should display “OFF” when powered 2.) Main circuit breaker off 3.) Transformer inoperative 4.) Interconnecting wiring malfunction

**TROUBLESHOOTING CHART CONTINUED:**

Should a problem occur that cannot be corrected after performing the above CHECKS, contact an **AUTHORIZED** repairman and/or Ultrafryer Systems Customer Service 1-800-525-8130 and provide the information acquired while performing these checks.

<u>ITEM</u>	<u>PROBLEMS</u>	<u>POSSIBLE SOLUTIONS</u>
9	High limit thermostat shutting down system	1.) Shortening level below minimum fill line 2.) Probe malfunction 3.) Controller malfunction
10	Excessive time to melt shortening	1.) Melt cycle timing incorrect 2.) Insufficient gas pressure 3.) Probe malfunction 4.) Control malfunction
11	Dry fire fry tank	1.) No shortening in vat 2.) Control malfunction 3.) Probe malfunction

**CAUTION: ENSURE REPAIRMEN ARE ADVISED THAT FRYER RESTRAINTS MUST BE DISCONNECTED/ RECONNECTED. IF A FRYER IS TO BE MOVED DURING MAINTENANCE OR REPAIR, AND THAT ELECTRICAL POWER AND GAS MUST BE TURNED OFF PRIOR TO PERFORMING ANY MAINTENANCE OR REPAIR.**

## **CLEANING**

## GENERAL CLEANING

Any item of equipment operates and lasts longer when kept clean and properly maintained, and the Ultrafryer is no exception. In order for this fryer to provide years of trouble-free service, it must be CLEANED and MAINTAINED according to the instructions listed below.

### DAILY

- 1) Clean the fryer surfaces periodically during operating hours with a solution of sanitizer and hot water, and at closing with stainless steel cleaner. If necessary, use a dampened type 7447 RED or 7440 BROWN (heavy duty) Scotch brite pad to remove encrusted material. DO NOT use steel wool, abrasive cloths, cleaners, powders, metal knife, spatula or any metal object to scrape stainless steel! Scratches on stainless steel are almost impossible to remove.
- 2) Filter the shortening in each fryer once a day or according to Company Policy.

### CAUTION:

**DO NOT ALLOW ANY CLEANING SOLUTION / WATER TO SPLASH INTO THE VESSEL OF HOT COOKING OIL AS IT WILL CONTAMINATE THE OIL AND MAY CAUSE THE OIL TO SPLATTER, CAUSING SEVERE BURNS**

### WEEKLY

- 1) BOIL-OUT the fryer vat using Boil Out Compound according to procedures in the cleaning manual provided by the chemical provider.
- 2) Perform steps 1 and 2 listed above under the Daily Cleaning.

**TECHNICAL ASSISTANCE, ORDERING INFORMATION**

**A. TECHNICAL ASSISTANCE** - Contact an authorized service agent or the Customer Service Department, Ultrafryer Systems at 1-800-525-8130 for technical assistance.  
E-Mail technical assistance at: techserv@ultrafryer.com

**B. ORDERING INFORMATION:**

1. **REPLACEMENT PARTS** - Provide the following information when ordering replacement parts by phone, fax or mail:

Your company name and phone number  
Your company purchase order number  
Bill-to address  
Ship-to address  
Quantity desired  
Part number and description of the desired-item Your name or signature of authorized-buyer

Phone in order to: 1-800-525-8130  
FAX order to: 1-210-731-5061  
Mail order to: Ultrafryer Systems  
Order Entry Office  
P.O. Box 5369  
San Antonio, TX 78201  
E-Mail your order to: custserv@ultrafryer.com

2. **TERMS** - Net 30 days for customers on approved accounts. Past due balances will be charged 1% per month (12% per annum) until full balance is paid.

3. **DAMAGES** - Ultrafryer Systems is not responsible for damage occurring in transit. All deliveries must be inspected for damage to shipping containers prior to departure of the delivering carrier. Any damage must be notated on the receiving document to facilitate filing of freight claims. Carriers must be notified immediately and freight inspections must be requested from the carrier. Ultrafryer Systems can and will gladly assist you in preparing and processing of the necessary claims only if proper notification has been accomplished on the carrier delivery document. Damaged equipment and or containers must be available for the claims inspector to inspect.

4. **RETURNS** - Ultrafryer Systems cannot guarantee credit for items returned without proper authorization. All returns must have prior Ultrafryer Systems Customer Service or Warranty department approval. An assigned number will be issued by the approval authority. Please print the assigned number on all returned packages and corresponding paperwork. Returned goods are subject to a 15% restocking charge. Ultrafryer Systems is not responsible for freight charges on returned goods unless authorized by Customer Service and or Warranty personnel. Ultrafryer Systems does not receive freight collect or C.O.D. shipments.

## **RECOMMENDED SPARE PARTS**

**A. RECOMMENDED SPARE PARTS**

To minimize downtime on the premix gas fryer upon failure of a component part, at least one (1) of the following items should be kept as a spare part in a local area:

PREMIX GAS FRYER RECOMMENDED SPARE PARTS LISTING	
<u>DESCRIPTION</u>	<u>PN</u>
Computer, Cook U23	22A651
Blower Premix 5.0 Power Burner and Gas Valve	17A031
Gasket, Blower Motor / Manifold IDE	22A810
Burner Infrared 1x3x8 W/ Mounting Plate	22A807
Rod, Ignitor Infrared Burner F/ 22A807	18610
Gasket, Mount Infrared Burner IDE 20in	22A811
Module, Ignitor Spark Dual Infrared	18A384
Transformer, Step Down 110V to 24V	18180
Transformer, FAST Wiring Harness	18A047
Relay, 24V DC 10 AMP SPDT Computer	23A023
Relay, 24V AC Flange Mounted	18A034
Relay, 24V AC DELAY ON MAKE	18A102
Control, 24VAC Universal Gas Blower (PWM)	23A462
Switch, Air Pressure	18A291
Switch, HI Limit	19B782
Probe, Temp Thermistor	18A006
Snap Light, Red Neon 125V 1/3 Watt	23043

## **PARTS IDENTIFICATION**

**MODEL F-ID-20X17 PREMIX GAS FRYER  
CONTROL PANEL**



<u>ITEM</u>	<u>DESCRIPTION</u>	<u>PN</u>
1	Computer, Cook U23	22A651
2	Snap Light, Red Neon 125V 1/3 Watt	23043

**MODEL F-ID-20X17 PREMIX GAS FRYER  
FRONT VIEW**

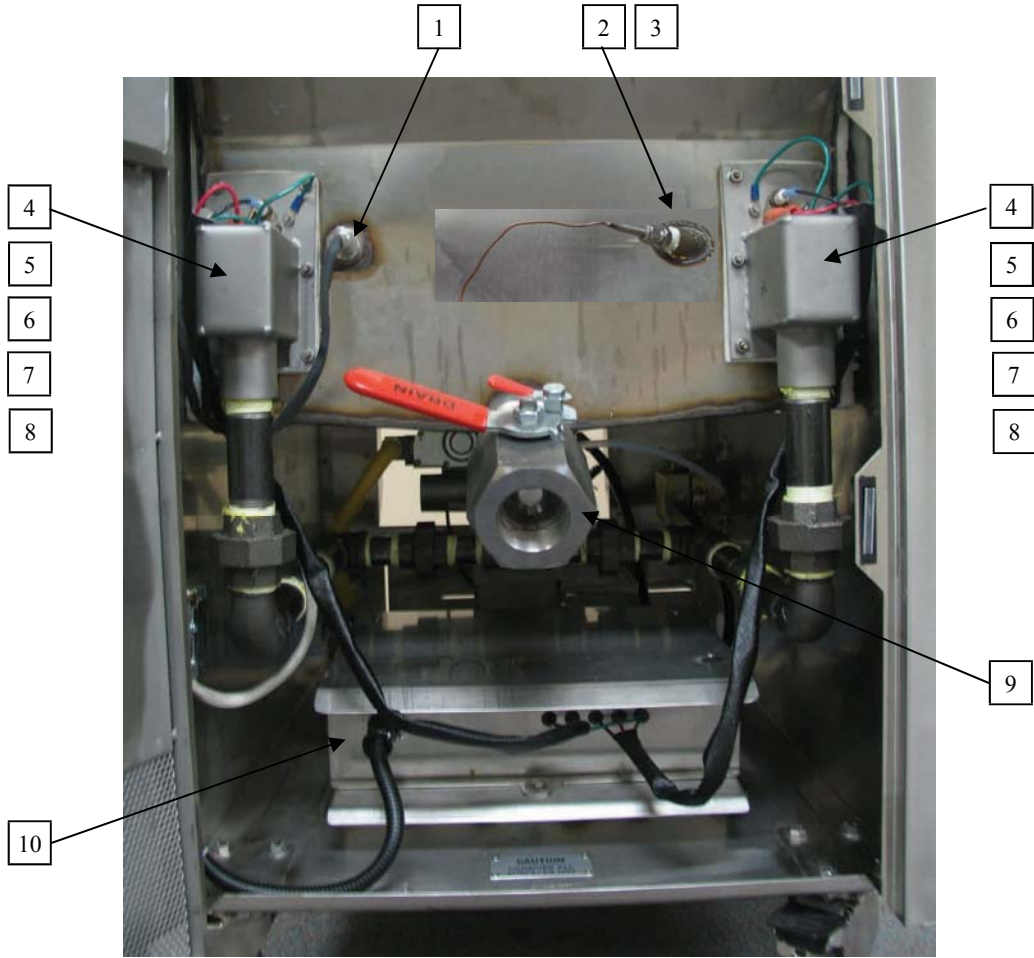

<u>ITEM</u>	<u>DESCRIPTION</u>	<u>PN</u>
1	Probe, Temp Thermistor	<a href="#">18A006</a>
2	Fitting, Compression Male 3/8 NPT	<a href="#">24A270</a>
3	Switch, HI Limit	<a href="#">19B782</a>
4	Box Mount, Infrared Burner	19C991
5	Burner Infrared 1x3x8 W/ Mounting Plate	<a href="#">22A807</a>
6	Rod, Ignitor Infrared Burner	<a href="#">22A807</a>
7	Gasket, Blower / Box IDE	22A803
8	Baffle, Agitator 20in IDE Front	19C993
9	Valve, Ball 1 1/2in Full W/ Lock Mech	<a href="#">24A204</a>
10	Box, Assy IDE Electrical Control	12D111

**MODEL F-ID-20X17 PREMIX GAS FRYER  
REAR VIEW**



<u>ITEM</u>	<u>DESCRIPTION</u>	<u>PN</u>
1	Box, W/ Flue F/ 20in IDE	19C992
2	Gasket, Blower / Box IDE 20in	22A803
3	Baffle, Agaitor 20in IDE Rear	19C994
4	Blower, Premix 5.0 Power Burner and Gas Valve	<a href="#">17A031</a>
5	Gasket, Blower Motor / Manifold IDE	<a href="#">22A810</a>
6	Switch, Air Pressure	<a href="#">18A291</a>

**BOX ASSEMBLY, IDE ELECTRICAL CONTROL**

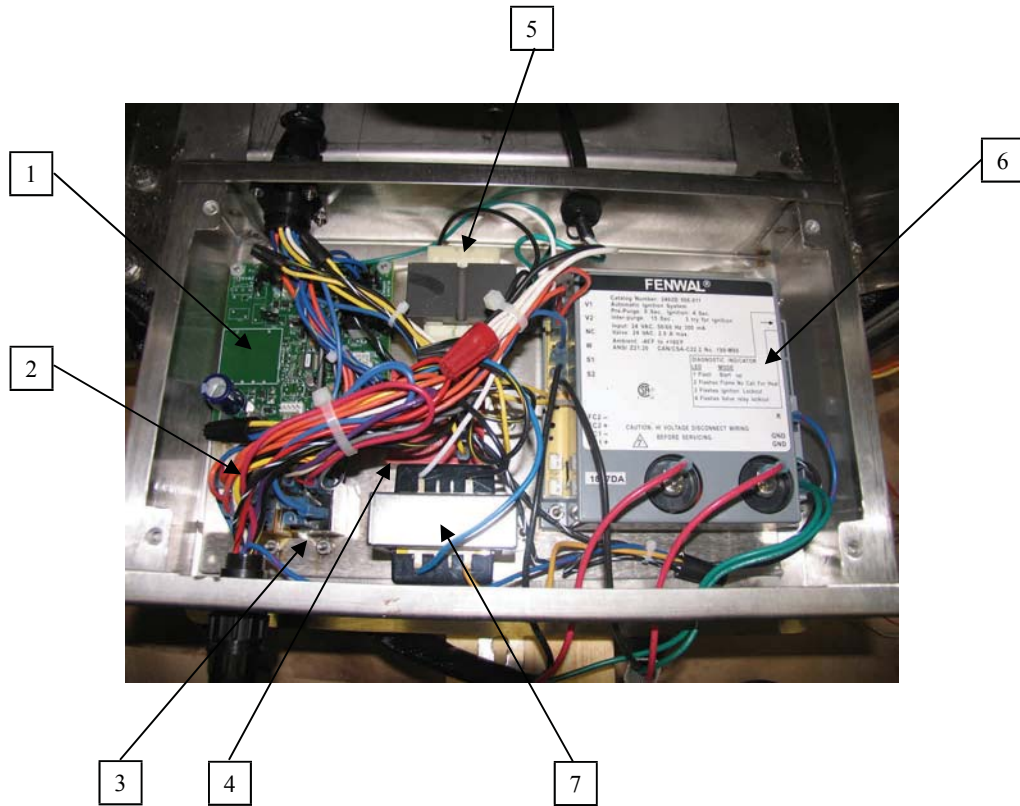

<u>ITEM</u>	<u>DESCRIPTION</u>	<u>PN</u>
1	Control, 24VAC Universal Gas Blower (PWM)	<a href="#">23A462</a>
2	Relay, 24V AC Flange Mounted	<a href="#">18A034</a>
3	Relay, 24V DC 10 AMP SPDT Computer	<a href="#">23A023</a>
4	Relay, 24V AC DELAY ON MAKE	<a href="#">18A102</a>
5	Transformer, FAST Wiring Harness	<a href="#">18A047</a>
6	Module, Ignitor Spark Dual Infrared	<a href="#">18A384</a>
7	Transformer, Step Down 110V to 24V	<a href="#">18180</a>

**SERVICE PROCEDURES AND ADJUSTMENTS**

**HARMONIC TONE**

Harmonic Tone (hum) at First Start, fryer will begin heating in low fire and a few seconds later go to high fire. There will be a harmonic tone that is NORMAL to hear. As fryer continues to heat, harmonic tone will dissipate and become less noticeable.

**GAS VALVE**

**WARNING:**

**DISCONNECT THE ELECTRICAL POWER TO THE FRYER.**

**WARNING:**

**SHUT OFF THE GAS BEFORE SERVICING THE FRYER.**

**WARNING:**

**ALL GAS JOINTS DISTURBED DURING SERVICING MUST BE CHECKED FOR LEAKS.  
CHECK WITH A SOAP AND WATER SOLUTION (BUBBLES).  
DO NOT USE AN OPEN FLAME**

The gas valve is considered part of the Blower Premix 5.0 Power Burner and Gas Valve assembly. If the gas valve fails and needs to be replaced, you must order a complete blower / gas valve assembly (burner). The reason for this is every blower / gas valve assembly (burner) is set up at the factory to operate at the most efficient level possible. This set up procedure can not be duplicated inn the field.

**MODULATING GAS VALVE ADJUSTMENTS**

**WARNING:**

**DISCONNECT THE ELECTRICAL POWER TO THE FRYER.**

**WARNING:**

**SHUT OFF THE GAS BEFORE SERVICING THE FRYER.**

**WARNING:**

**ALL GAS JOINTS DISTURBED DURING SERVICING MUST BE CHECKED FOR LEAKS.  
CHECK WITH A SOAP AND WATER SOLUTION (BUBBLES).  
DO NOT USE AN OPEN FLAME**

The modulating gas valve is adjustable at the factory and requires no adjustments. If the modulating gas valve needs to be replaced, the new gas valve from the factory will be adjusted properly and will only need to have the gas pressure verified coming into the gas valve.

**INFRARED BURNER SPARK IGNITOR AND TEMP PROBE SETTINGS**

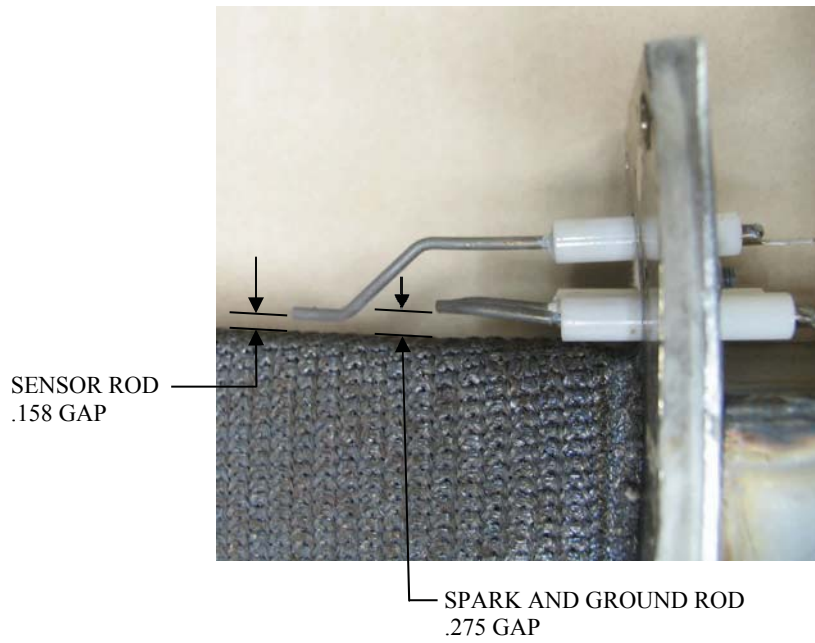

**GROUND ROD  
GROUND WIRE CONNECTION**

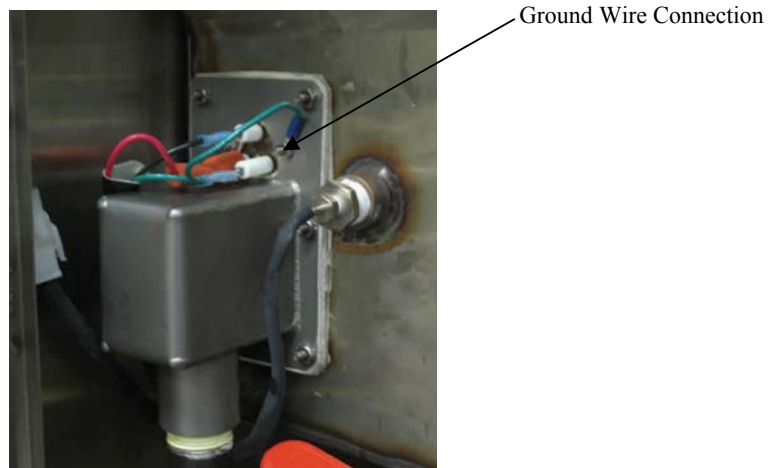

## CONTROL, 24VAC UNIVERSAL GAS BLOWER (PWM) SETTINGS

Dip Switch Settings

- #1 = OFF
- #2 = OFF
- #3 = OFF
- #4 = ON

Low Fire Setting = A

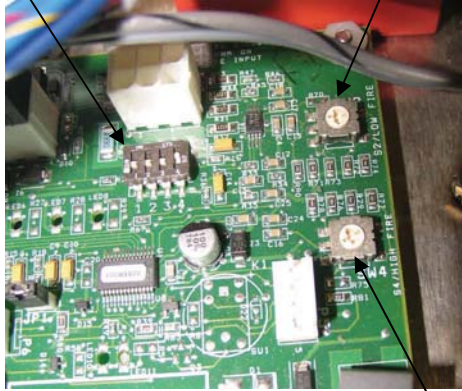

High Fire Setting = D

## DELAY ON MAKE SETTING

Setting = 2 Second

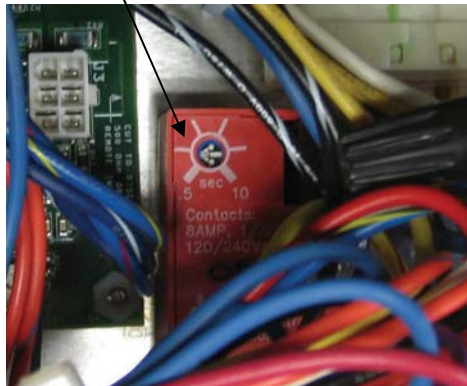

### TEMPERATURE PROBE SETTING

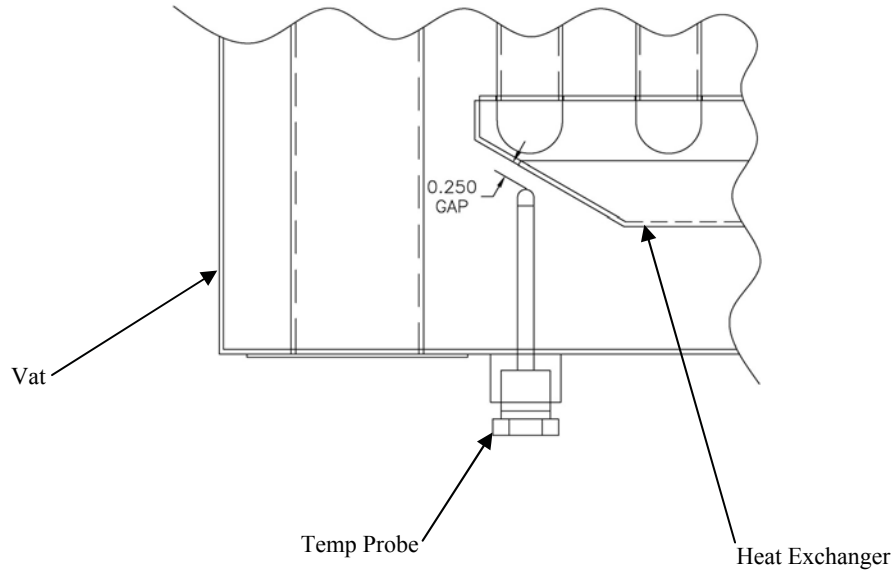

### HI LIMIT PROBE SETTING

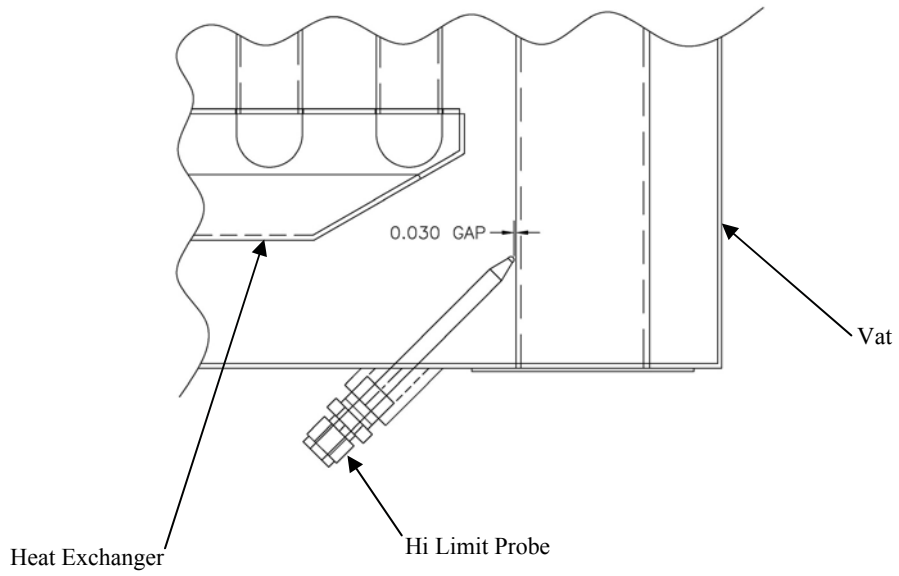

## **WIRING DIAGRAM**

