

# AURA



TECHNICAL NOTE

**Thank you for choosing UNIC, the first French manufacturer of professional espresso machines since 1919**

The manufacturer reserves the right to modify the appliance presented in this publication without notice.  
Read carefully the safety instructions before use.

AU9061 07/2019

**UNIC**



# Table des matières

▶ Safety advice .....	5
<b>1- INSTALLATION &amp; MAINTENANCE .....</b>	<b>6</b>
▶ Preparing the machine .....	6
♦ <i>Unpacking the machine</i> .....	6
♦ <i>Preparing the site and installing the machine</i> .....	6
♦ <i>Fitting high feet (optional)</i> .....	6
▶ Water connection .....	6
▶ Electrical connection .....	7
♦ <i>Electrical connections</i> .....	7
♦ <i>Connection Diagrams</i> .....	7
▶ Starting up .....	8
♦ <i>Filling the boilers</i> .....	8
♦ <i>Steam boiler</i> .....	8
♦ <i>Internal boilers</i> .....	8
♦ <i>Heating</i> .....	8
▶ Checks & adjustments.....	8
♦ <i>Adjusting the temperature using the pressure switch</i> .....	8
♦ <i>Adjusting the expansion valve</i> .....	8
♦ <i>Adjusting the pump pressure</i> .....	9
♦ <i>Adjusting the water entry solenoid valve</i> .....	9
♦ <i>Adjusting the coffee grinding</i> .....	9
♦ <i>Ambiance lighting</i> .....	9
♦ <i>Adjustment of mixer tap for the hot water</i> .....	9
♦ <i>Sensibility of keyboard</i> .....	10
♦ <i>Softener</i> .....	10
♦ <i>Cup seal</i> .....	10
♦ <i>Removing the grille</i> .....	11
▶ Maintenance .....	12
♦ <i>Specifications</i> .....	12
♦ <i>Chart of LED signals</i> .....	13
♦ <i>Dosamat display</i> .....	13
♦ <i>2 Cups Display</i> .....	14
♦ <i>Steamair display</i> .....	15
♦ <i>Codes Error</i> .....	16
♦ <i>Procedure for updating software</i> .....	18
♦ <i>Copy the file into the USB key</i> .....	18
♦ <i>Updating the machine</i> .....	19
▶ Wiring diagrams .....	20

<b>2- USE &amp; PROGRAMMING .....</b>	<b>22</b>
▶ <b>Presentation of the various keyboards .....</b>	<b>22</b>
♦ <i>4 doses keyboard .....</i>	<i>22</i>
♦ <i>Dosamat keyboard .....</i>	<i>22</i>
♦ <i>Hot water &amp; steam keyboard .....</i>	<i>23</i>
♦ <i>SteamAir keyboard .....</i>	<i>23</i>
♦ <i>Key operation.....</i>	<i>24</i>
♦ <i>Setting default.....</i>	<i>24</i>
♦ <i>Different levels of menus .....</i>	<i>25</i>
♦ <i>Access to parameter .....</i>	<i>26</i>
♦ <i>The menu tree.....</i>	<i>27</i>
▶ <b>PROGRAMMING THE DIFFERENT VOLUMES OF COFFEE .....</b>	<b>31</b>
♦ <i>Electronic box.....</i>	<i>31</i>
♦ <i>Use .....</i>	<i>31</i>
♦ <i>Programming.....</i>	<i>31</i>
♦ <i>Dosamat box .....</i>	<i>31</i>
♦ <i>4 doses box.....</i>	<i>32</i>
♦ <i>Copy setting between coffee boxes .....</i>	<i>32</i>
♦ <i>Reset to factory values .....</i>	<i>32</i>
♦ <i>Option SteamAir.....</i>	<i>33</i>
♦ <i>Components .....</i>	<i>33</i>
♦ <i>SteamAir key.....</i>	<i>33</i>
♦ <i>SteamAir temperature adjustment .....</i>	<i>33</i>
▶ <b>Cleaning .....</b>	<b>34</b>
♦ <i>Reference of cleaning tools: .....</i>	<i>34</i>
♦ <i>After each use.....</i>	<i>34</i>
♦ <i>Steam output tube: .....</i>	<i>34</i>
♦ <i>Daily.....</i>	<i>34</i>
♦ <i>Before use or after several hours of inactivity: .....</i>	<i>34</i>
♦ <i>After the service : .....</i>	<i>34</i>
♦ <i>Weekly .....</i>	<i>35</i>
♦ <i>Filter holder cup.....</i>	<i>35</i>
♦ <i>Basin.....</i>	<i>35</i>
♦ <i>Bodywork.....</i>	<i>35</i>
♦ <i>Cleaning coffee groups.....</i>	<i>35</i>
♦ <i>Launching of cleaning after group blocked: .....</i>	<i>35</i>
♦ <i>Launch of cleaning Volunteer: .....</i>	<i>35</i>
♦ <i>Keyboards cleaning .....</i>	<i>36</i>
▶ <b>List of color LED .....</b>	<b>37</b>

## ► Safety advice

This device is intended to be used only for its specific use.  
The manufacturer disclaims any liability for damage caused by abnormal use or abuse.

Children 8 years of age or older and persons with reduced physical, mental or sensory abilities, or lack of experience and skill may use this device, if supervised by a qualified person, or they have received the instructions for use and security necessary to understand the risks involved.

Supervise children to make sure they do not play with the appliance and they can't make the cleaning & maintenance of the machine.

Do not leave the packaging elements within reach of children. These elements are potentially a source of danger.

The installation must be done by a qualified technician and following local and national regulations. He is the only one to be authorized to access the internal parts of the device for maintenance and repair.

Use only the technical and spare parts manuals for proper functioning of the machine, and avoid compromising safety.

Access to the service area is limited to persons with the necessary knowledge of safety and hygiene as well as practical experience of the device.

Leave enough free space around the machine to facilitate its use and to perform any maintenance operations.

The device **must not be**:

- exposed to the elements of the external environment or placed in damp places,
- exposed to a water jet or splashing.
- installed in areas where the jets or high pressure cleaners are used.

The device **must be**:

- placed on a stable, level and horizontal surface
  - used at an ambient temperature of 5°C to 35°C (41°F - 95°F), (if it is stored at an ambient temperature below 5°C (41°F) the water circuit (boiler-piping) must be drained.)
  - if the device freezes, wait 24 hours at a minimum temperature of 10°C (50°F) before restarting the device.
- Before connecting the power and water supplies, check that the electrical and water network are in accordance with the technical information plate of the device.

The power supply must be provided with the following safety features: power switch which completely isolates the machine from the mains (gap between contacts of at least 3 mm), efficient earthing and an effective circuit breaker for protection against earthing leaks; section of the conductors appropriate for a power capacity.

Before connecting or disconnecting the power cable, switch the main switch onto position 0. If the power supply cable is damaged, it must be replaced by the manufacturer, by its after-sales service technician or similarly qualified persons, to avoid any danger.

For electrical safety, make sure that the device is properly earthed.

The manufacturer disclaims any liability for damage caused by improper earthing.

The device must be connected to a water network with a pressure of 1 to 8 bar (0.1 to 0.8 MPa) and a tap readily accessible must be fitted in front of the water supply tube. The device is to be installed with adequate backflow protection to comply with applicable federal state and local codes.

In case of emergency (fire, surge, abnormal noise, etc. the first thing to do is to cut off the current and close the water tap.

Be careful not to obstruct the air inlets of the machine with towels or other objects.

Beware of hot surfaces such as cup heaters, the unit heads and the hot water and steam outputs.

Never install containers filled with liquid on the top of the machine.

Beware of jets of hot water or steam.

The machine should be descaled only by a qualified technician.

## 1-INSTALLATION & MAINTENANCE

### ► Preparing the machine

The machine is delivered in a cardboard box and is screwed onto a wooden pallet.

#### ◆ Unpacking the machine

- Cut the strapping.
- Open the crate and take out the box containing the accessories.
- Unscrew the nuts securing the machine to the pallet.
- Separate the cardboard box from the pallet.
- Remove the machine from the pallet and place it on wooden blocks.
- Remove the transport screws and washers.

#### ◆ Preparing the site and installing the machine

- Position the machine in its final location, and level it with rubber washers if necessary.
- The machine must be installed on a flat surface.
- It is necessary to leave a space of 5 cm at the back. Do not obstruct the air intakes provided on the top of the machine.
- An earthed electric socket corresponding with the characteristics of the machine and a water supply are enough.
- The canopies are put in place after the settings have been done.
- The machine must not operate without its feet.

#### ◆ Fitting high feet (optional)

Reference UNIC feet NSF: **NM-176**

Reference UNIC M8 x 16 bolts: **50402**

For fitting the aluminium feet, once the machine is installed in its location:  
Screw the 50402 bolts to the aluminium feet, tip the machine onto the front two feet to screw in the aluminium feet at the base of the rubber feet at the back, and then do the same operation for bolting the feet to the front.

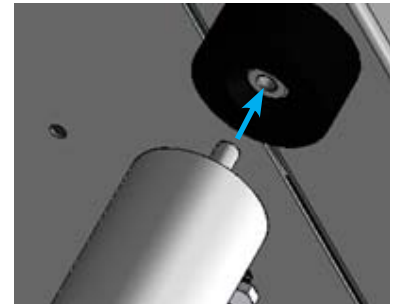

### ► Water connection

Water softener essential above 5° KH

Water supply:

- Pressure: 0 - 8 bars (0.1MPa - 0.8 MPa).
- Union: 3/8 female gas (male union on the machine).
- Tube: internal diameter 8 mm minimum.
- Provide a shut-off tap.

Work on the right side of the machine:

Unscrew the bolt (ref. NM096) at top at the cup heater.

Slide the side toward the back.

Screw the water inlet tube to the union in the machine (photo opposite).

Draining:

- Union: Ø18 mm (female on the machine).
- Tube: internal diameter 12 mm minimum.

The drain tube is supplied fitted on the machine. It is held by an adjustable Rilsan collar. Dislodge the tube from the collar.

Then connect the other end of the drain tube to a waste water drain by ensuring that no adverse slope interferes with good outflow.

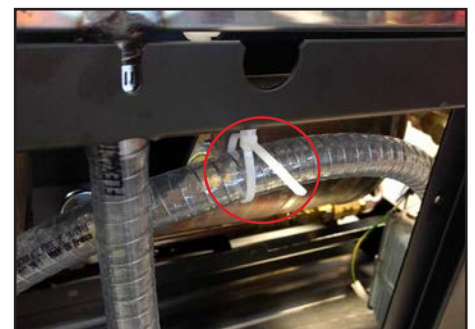

## ► Electrical connection

- None of the switches on the machine must be on.
- Check that the values of the voltage, frequency and power shown on the technical information plate of the device match those of the mains.=

### ◆ Electrical connections

Put the switch of the machine on position 0.

The machine is delivered with a cable of 3 or 5 numbered wires (including the earth wire).

It is necessary to check that the wiring of the machine matches the available mains voltage, in accordance with the connection diagrams below. If necessary, modify by working on the power supply cable and the terminal block located in the vicinity of the pressure switch.

### ◆ Connection Diagrams

A : Electronic box  
B : Switch  
N = NEUTRAL

1 = BROWN PHASE  
2 = BLACK PHASE  
3 = GREY PHASE

IN ALL CASES THE GREEN/YELLOW WIRE MUST BE CONNECTED TO THE EARTH OF THE INSTALLATION

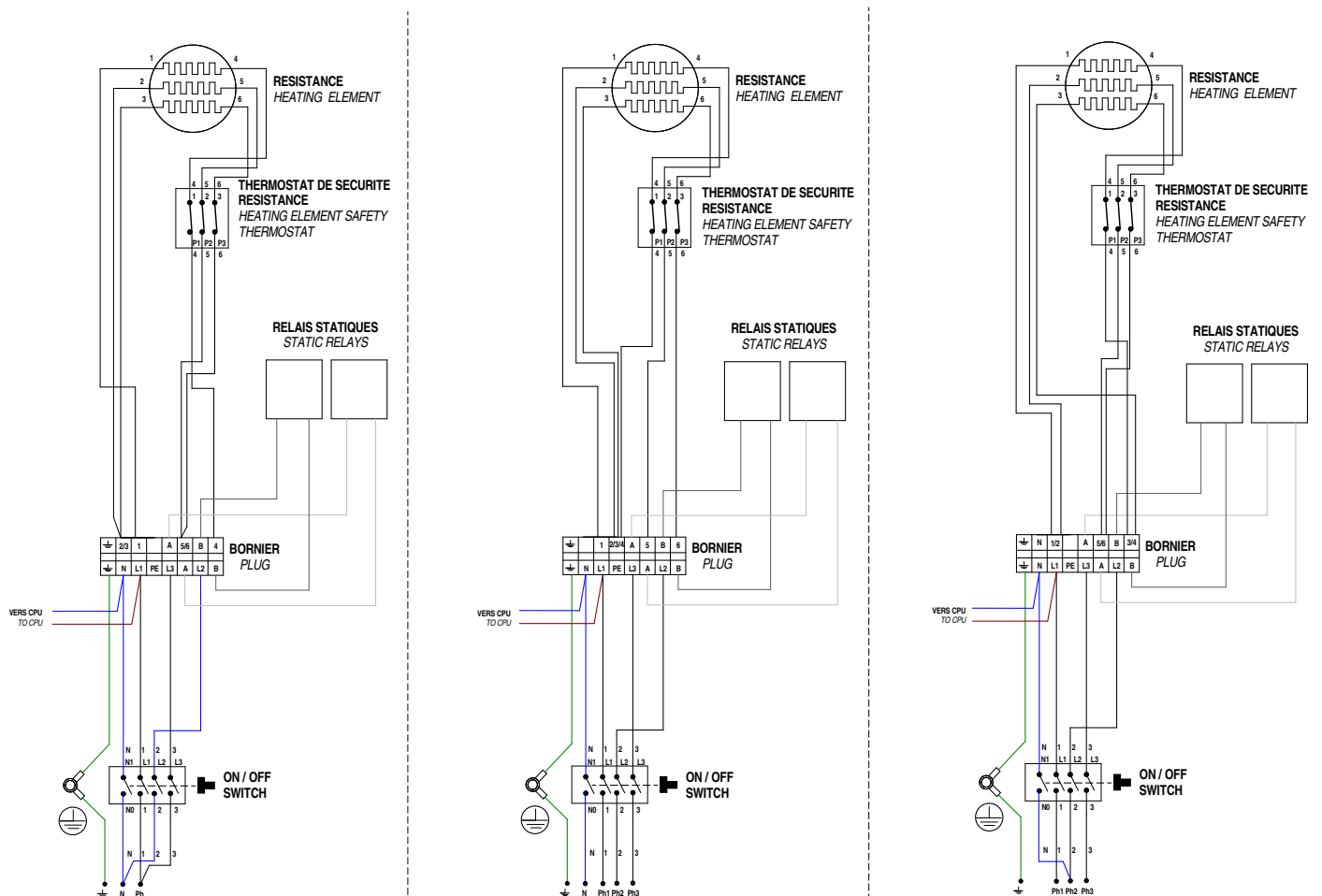

200 / 230 / 240 MONO + TERRE

200 / 230 / 240  
SINGLE PHASE+EARTH

380 / 400 / 415 TRI+N+TERRE

380 / 400 / 415  
3-PHASE+N+EARTH

200 / 230 / 240 TRI + TERRE

200 / 230 / 240  
3-PHASE+EARTH

## ► Starting up

### ◆ Filling the boilers

- Open the water shut-off tap.
- Connect the mains electric plug.
- Turn the power switch onto 1.

**Do not put on position 2 for as long as the boiler is not filled.**

#### ◆ Steam boiler

When the switched on, the filling is done automatically.  
A safety is provided, if the filling is not done before 3 minutes. In this specific case, the solenoid valve for filling and the pump cut off.  
The display shows **FL** blinking.

- Check the machine's water supply.
- Shut down and restart the machine by turning the power on switch onto 0 then on 1.
- The filling starts again for 3 minutes.

#### ◆ Internal boilers

With the filter holder in place, press the Continuous / Stop key  of each unit. As soon as the water flows properly by the beak, (without air) press the same key again to stop the water.

### ◆ Heating



When the filling is complete, turn the power switch onto 2.

When the operating temperature of the machine is reached, the pressure gauge should indicate a pressure of 0.9 to 1 bar (0.09MPa et 0.1MPa) (the pressure is visible when we press on setting key ).

**It is advisable to leave the machine on heating continuously and to leave the filter holders engaged on the machine outside the infusion periods.**

## ► Checks & adjustments

### ◆ Adjusting the temperature using the pressure switch

The temperature's setting is electronic, make this setting on the left group.  
Press 3 seconds on setting key , menu **da** appears,  
Press a second time on setting key , the menu **P-5** (means pressure),  
Enter in this menu by pressing the cleaning key .

In the menu:

**INCREASE** the pressure with the key  **DECREASE** the pressure with the key   
Adjust a pressure between 0.9 and 1 bar (0.09MPa et 0.1MPa) for a temperature of 120°C (248°F).  
Validate setting on by pressing on key  and to exit of the settings press 3 seconds on the key .

### ◆ Adjusting the expansion valve

The valve is located at the top, on the right rear of the machine. It is necessary to remove the right side. The valve must open at about 13 bar (1.3MPa) (gauge green scale).

- If it opens ABOVE 13 bar: **UNSCREW**
- If it opens BELOW 13 bar: **SCREW IN**

Use a lug wrench (ref: OU003). After adjustment, do not forget to lock the lock-nut.

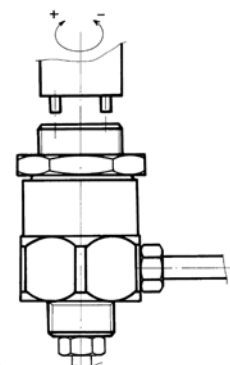
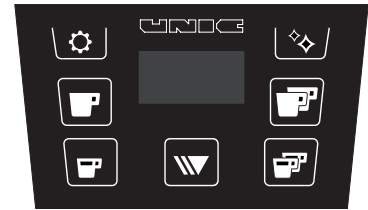

### ◆ Adjusting the pump pressure

In infusion, the pressure must be 9 to 10 bar (0.9MPa et 1MPa) (gauge green scale).  
The pump is located on the right side of the machine and is adjusted by this same side.

**SCREW IN** to INCREASE the pressure,  
**UNSCREW** to DECREASE the pressure,

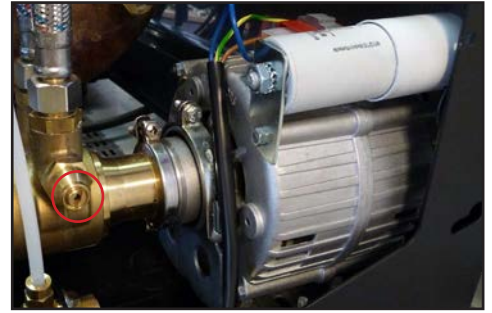

### ◆ Adjusting the water entry solenoid valve

The solenoid valve is located at the top, on the back-right of the machine. It is necessary to remove the cup heater.

Machine at temperature, launch a cycle (with coffee) continuously on each unit simultaneously.  
Make the boiler fill up (draw hot water). Adjust the maximum flow rate of the solenoid valve so as not to descend below 7 bar (0.7MPa).  
Then check that the filling time of the boiler is not excessive.



### ◆ Adjusting the coffee grinding

Wait until the machine has reached the set temperature 0.9 to 1 bar (0.09MPa à 0.1MPa).

It is the finesse of the grinding which determines the time for passing the hot water through the dose. This time is usually monitored by using the two-cup filter with two doses of coffee.

Average passing time for 2 cups (6 to 7 cl. per cup): 30 to 35 seconds.

- If this time is shorter, reduce the grinding.
- If this time is too long, increase the grinding.

To obtain a good result, use at least 6 g. of (good) ground coffee per cup.

### ◆ Ambiance lighting

The switch for the ambient lighting is located to the left of the machine near the basin. It lights up the grille strip, and if your machine is so equipped, the lighting of the cups. 0=OFF & 1=ON.



### ◆ Adjustment of mixer tap for the hot water

The mixer tap is located at the top, on the front-right of the machine. For access, it is necessary to remove the right side.

The temperature range is 55°C to 95°C (131°F à 203°F). To adjust the desired temperature, use a flat screwdriver. We adjust the cold circuit electrovalve, open at his maximum the high circuit electrovalve.

Make the settings during the hot water cycle.

**SCREW IN** to INCREASE the temperature,  
**UNSCREW** to DECREASE the temperature.

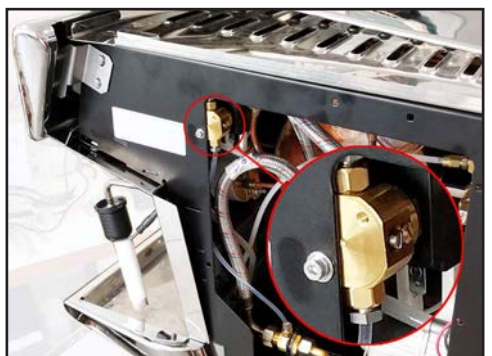

### ◆ Sensibility of keyboard

**WARNING, intervene on this setting only in case of specific need**

It's possible to change the touch behavior during extreme use (presence of moisture and / or dirt on the keyboard).

Go into the menu **☰**, there are 3 levels of setting, 0 (default) the most responsive, 2 the least responsive.

### ◆ Softener

Two water softener suppliers are available at UNIC SA.

BRITA®

BESTMAX™

Test the water hardness of the network and refer to the technical documentation of the water softener used for optimum adjustment.

*Note: A softener must be changed every 1 year, even if it does not reach the end of its filtering capacity.*

### ◆ Cup seal

- Remove the unit cover.  
(Attention if the machine is equipped with LED lighting, disconnect the cable)

- Remove the cup holder (Allen key No. 6) and the filter (pipe wrench of 8 mm).

- Unscrew the 2 screws of the tamper and remove the piston spring assembly (photos no. 1 and no. 2).

- Remove the 2 O-rings and the piston cup seal.

- Clean the assembly.

- Lubricate the seal Ref 27718 (silicone grease) and position it at the base of the unit (photos no. 3 and no. 4).

- Prepare the tamper NZ4007, piston NZ4008 and spring 28828 assembly (without seals), and then position and screw the assembly (photo no. 6).

- Install the O-ring 27800 (photo no. 7).

- Install the cup seal PC-17 (photo no. 8).

- Refit the ID-103 filter and the diffuser 31910 (pay attention to the direction of the diffuser) (photo no. 9).

- Attach the cup holder NZ4011.

- Make 2 espressos and check the mobility of the piston and the sealing (photo no. 10).

- Refit the LED cable and unit cover assembly.



### ◆ Removing the grille

To remove the grille:

Remove the cup heater glass panels from the machine



1

Unscrew the 2 pan-head screws and 1 allen key screw (2.5 mm key).



2

Remove the side panels and cup heaters.



3

Pull the grille upwards to get it out of its place.



4

There is no screw above the grille.

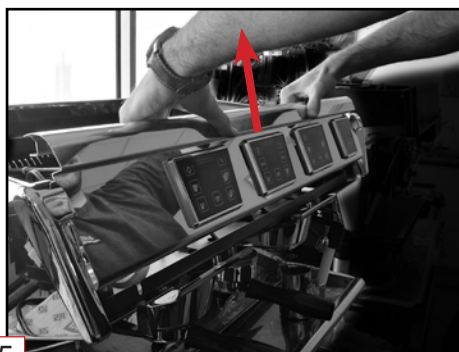

5

To refit the grille, perform the same operations in reverse order.

## ► Maintenance

VERY IMPORTANT!

BEFORE UNDERTAKING ANY ACTION, MAKE SURE ALL SETTINGS ARE CORRECT.

- TEMPERATURE 120°C (248°F).

STEAM PRESSURE: 0,9 TO 1 bar (0.09MPa to 0.1MPa).

- INFUSION PRESSURE: 9 TO 10 bar (0.9MPa to 1MPa).

The HP valve opens for a value greater than 13 bar (1.3MPa).

- SUPPLY PRESSURE: 1 TO 8 bar (0.1MPa to 0.8MPa).

If the machine sucks water into a reservoir, check the level of the tank and the state of cleanliness of the footstrainer valve if it is installed

- PRECAUTIONS TO TAKE

A. Switch off the machine before any work on the electrical circuits.









B. Cool the machine and make the pressures drop before any work on the hydraulic circuit.

### ◆ Specifications



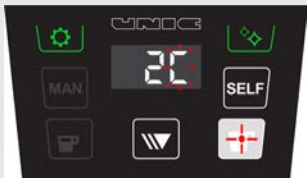

DIMENSIONS	AURA 2GR	AURA 3GR	SETTINGS	
Width	79 cm / 31"	98 cm / 38.5"	Temperature	118 to 120°C 244 to 248°F
Height	48 cm / 19"	48 cm / 19"	Steam pressure	0.9 to 1 bar 0.09 to 0.1 MPa
Depth	60 cm / 23.6"	60 cm / 23.6"	Pump pressure	9 to 10 bar 0.9 MPa to 1MPa
Weight	70 kg / 154.3 Lb	80 kg / 176.3 Lb	HP valve	13 bar / 1.3 MPa
Power			LP valve	3.2 bar / 0.3 MPa
110V mono	-	-	Dose of ground coffee	7 g
200V mono	3.5 kW (option 2.3)	3.5 kW	Water dose	5 to 7 cl
220V mono-380V tri+N	4.3 kW (option 2.7)	4.3 kW	Infusion time	20 to 25s
230V mono-400V tri+N	4.7 kW (option 3)	4.7 kW		
240V mono-415V tri+N	5.1 kW (option 3.2)	5.1 kW		

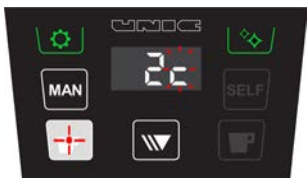
## ◆ Chart of LED signals







### ◆ Dosamat display

Normal operation	Touchpad	Comments
Starting machine		Snap the filter holder on the group for activate the coffee keys
Ready (self mode)		(Touch continu/stop ON) Coffee buttons active to switch dose. In This example, large dose shown because the last dose used, is large dose. Without filter holder
Ready (self mode)		(Touch continu/stop ON) Coffee buttons active to switch dose. In This example, 2 large doses shown because the last dose used, is 2 large doses. With filter holder
During time self (self mode)		Buttons not active
During cycle (self mode) (2 large cups shown)		Coffee buttons active to switch dose. And only touch continu/stop active to stop cycle.
During continue cycle (self mode)		Stop cycle by pushing only continu/stop button.
Ready (manual mode)		Without filter holder
Ready (manual mode)		With filter holder. In this example 2_ because 2 cups filter holder inserted.
During cycle (manual mode) (2 small cups shown)		You can stop cycle only by continu/stop button. Coffee buttons active to switch dose.



♦ 2 Cups Display

Normal operation	Touchpad	Comments
Ready		All Buttons active. (touch continu/stop ON)
Ready		Only button continu/stop not active. (touch continu/stop OFF)
During cycle (1 Small cup shown)		Coffee buttons active to switch dose. And touch continu/stop active to stop cycle.
Coffee dispensing (2 large cups shown)		Stop cycle by pushing button again or button continu/stop. Or button 2small cups if small dose is achieved
During continue cycle		Stop cycle by pushing any button.

◆ Steamair display

SteamAir Box	Touchpad	Comments
Ready		Continu/stop not active. (touch continu/stop ON)
Small hot water cycle		We Can stop the cycle manually with small hot water & continu/stop buttons. (Security at 105 seconds)
Large hot water cycle		We Can stop the cycle manually with large hot water & continu/stop buttons. (Security at 105 seconds)
Steam cycle		We Can stop the cycle manually with steam & continu/stop buttons. (Security at 180 seconds)
Automatic <b>SteamAir</b> cycle		We Can stop the cycle manually with stemair & continu/stop buttons.
Simultaneous cycle of small hot water & steam		Display show steam in priority. We Can stop the cycles manually with continu/stop button.

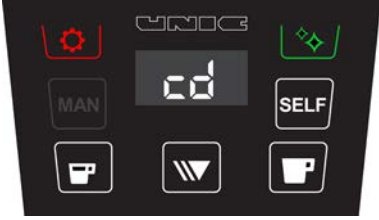
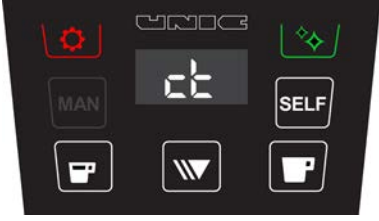
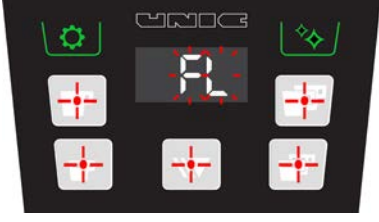
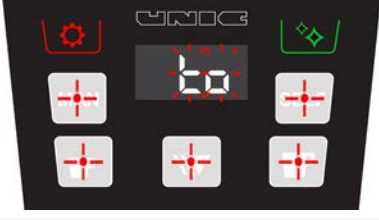
♦ Codes Error

LED signals Code error	Touchpad	Comments
Flow meter disconnected		No dosage but you Can delivering a coffee in self and manual mode.
Flow meter in short circuit		No dosage but you Can delivering a coffee in self and manual mode.
Flow meter no signal		No electrical problem, but no signal, propeller is blocked
Flow meter time out		Time out during a coffee cycle. Time-out at 2 min (120s)
Machine startup Boiler Filling (0 bar) Safeguard		FL=Filling
Boiler Filling Safeguard (Machine cold, 0 bar)		To=Time out at 3 min (180s) Machine is blocked no heating Check the water supply
Boiler Filling Safeguard (Machine hot, ~1.2 bar)		to= Time out at 1min 45seconds Hot water/steam box is locked Coffee box work's

Pressure sensor disconnected		Heating doesn't work, but you can deliver a coffee
Pressure sensor short circuit		Heating doesn't work, but you can deliver a coffee
Heating security		Heating doesn't work, but you can deliver a coffee
hall sensor dosamat		Only manual works. Coffee button not active. Continuation/stop button active.
hall sensor dosamat		Only manual works. Coffee button not active. Continuation/stop button active.
<b>SteamAir</b> probe disconnected (Only if StA is ON)		(When StA is ON) Hot water and normal steam active. <b>SteamAir</b> not active.
<b>SteamAir</b> probe disconnected		(When StA is OFF) Hot water and normal steam active. <b>SteamAir</b> active like normal steam = By time.

## ◆ Procedure for updating software

### ◆ Copy the file into the USB key

Use an USB key standard type A



#### 1 Format the key (right click > Format) (option)

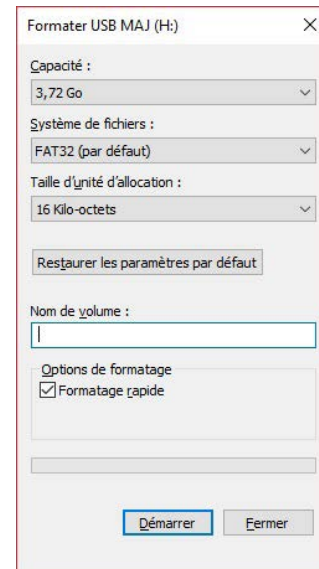

#### 2 Copy the received file in the USB key

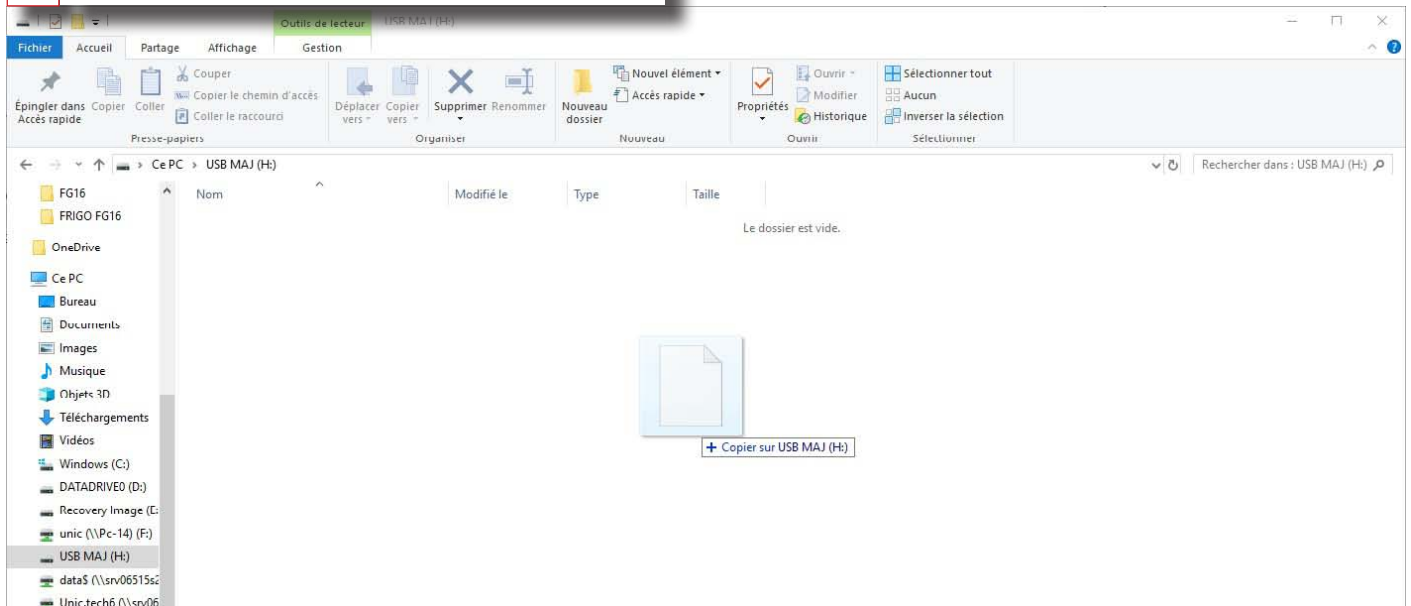

#### 3 Rename the file (right click > Rename)

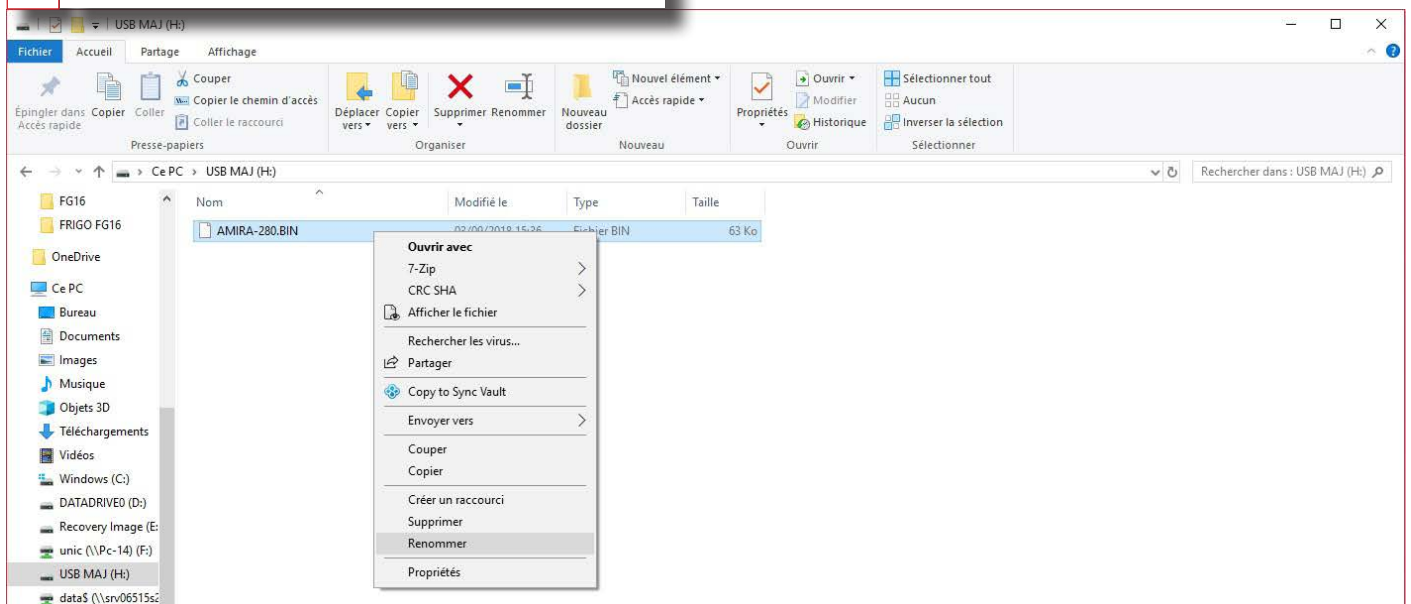

#### 4 Rename *AMIRA-280.BIN* by **AMIRA.BIN**

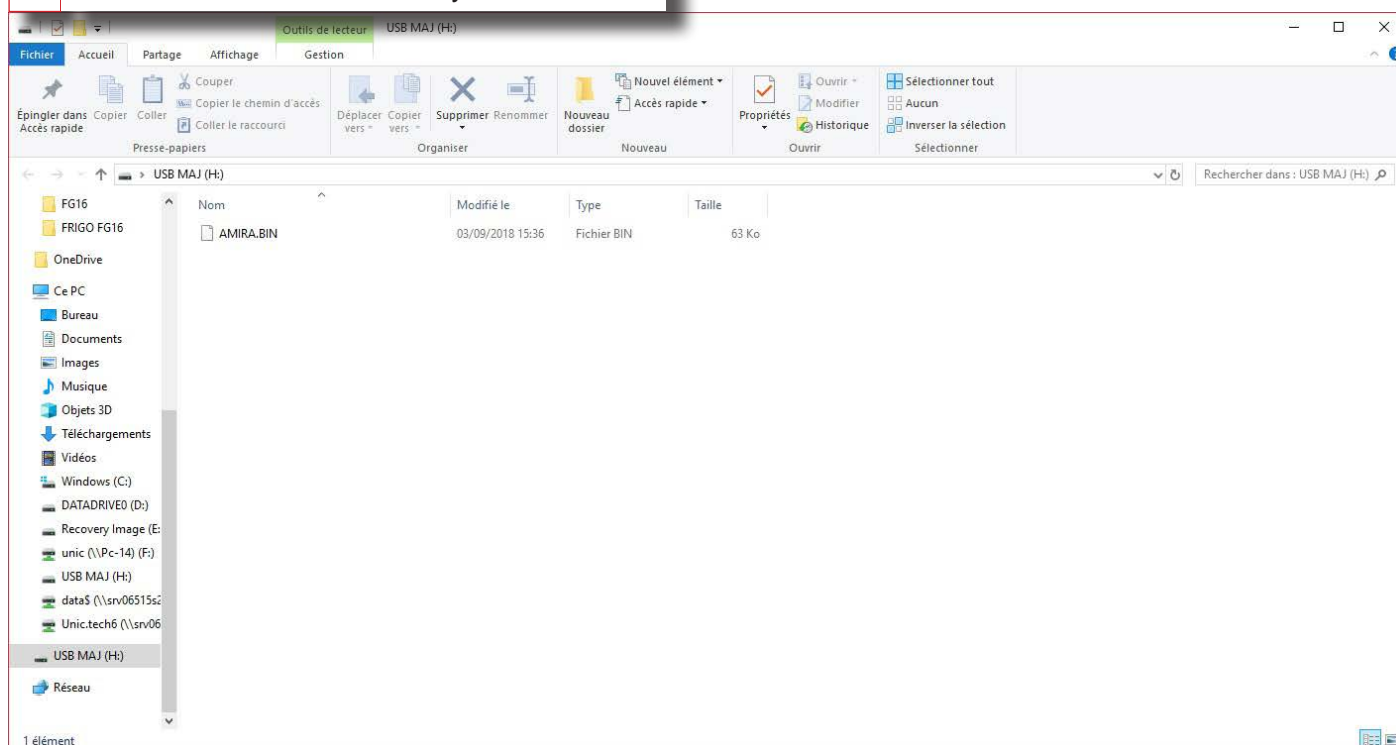

**The USB key is now ready to update the machine.**

#### ◆ Updating the machine

**WARNING:** The operation must be performed by a qualified technician.  
Step 4 requires power to the machine with the covers off.

1. Turn the main power switch to position 0
2. Remove the left side panel, the card is accessible
3. Insert the USB key into the USB port
4. Turn the main power switch ON (position 1)

**Waiting 10 seconds**

**DO NOT TURN OFF OR UNPLUG THE USB DURING UPDATE**

5. Turn the main power switch OFF (position 0)
6. Remove the USB key (The machine will not function with the card in place)
7. Replace all covers and panels
8. Turn ON the machine
9. Check programmed settings for coffee, water and steam

**The machine is now up to date**



► Wiring diagrams

Wiring diagram  
AURA 3GR 230V mono

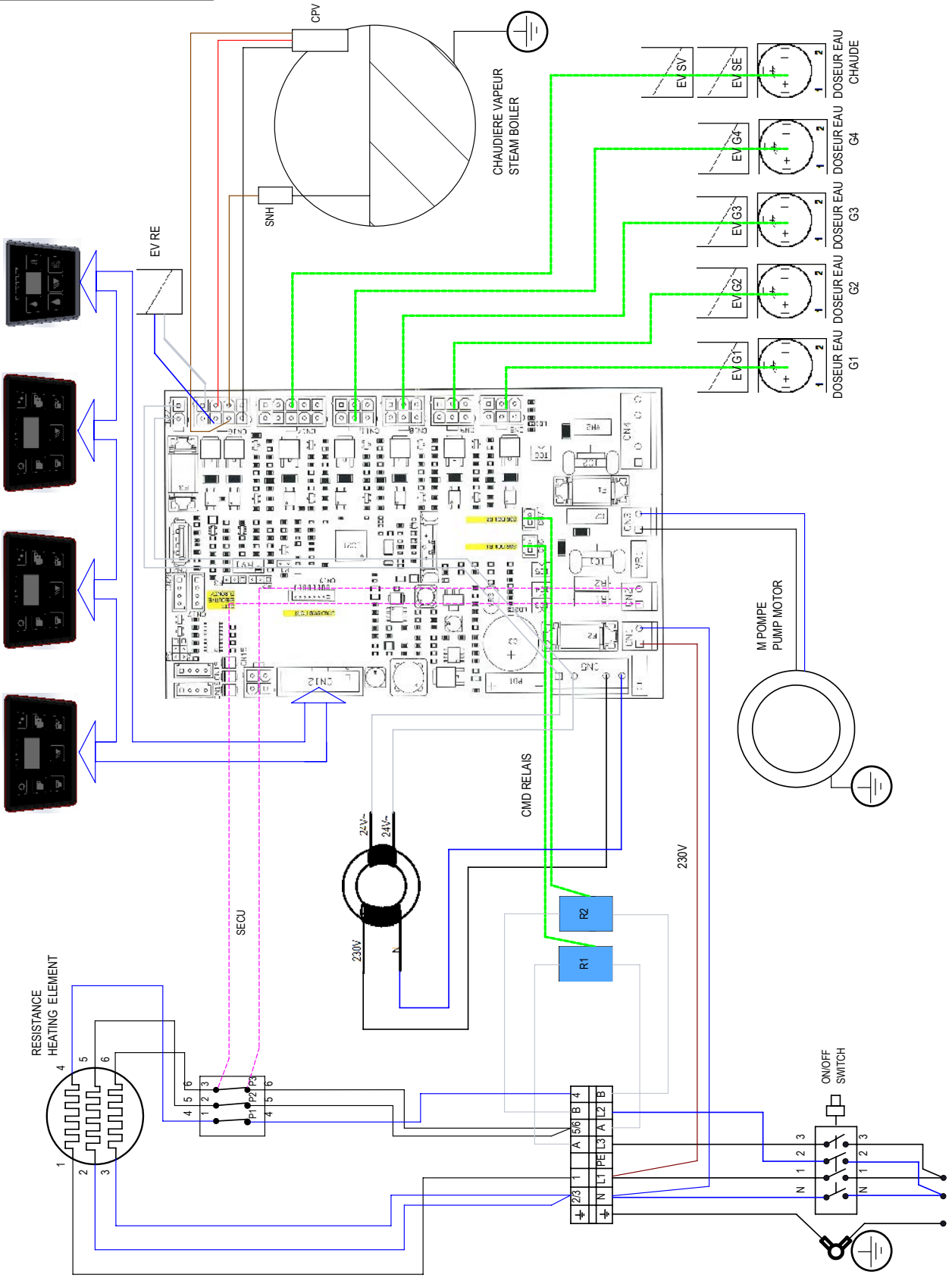

Wiring diagram  
AURA 3GR 400V tri

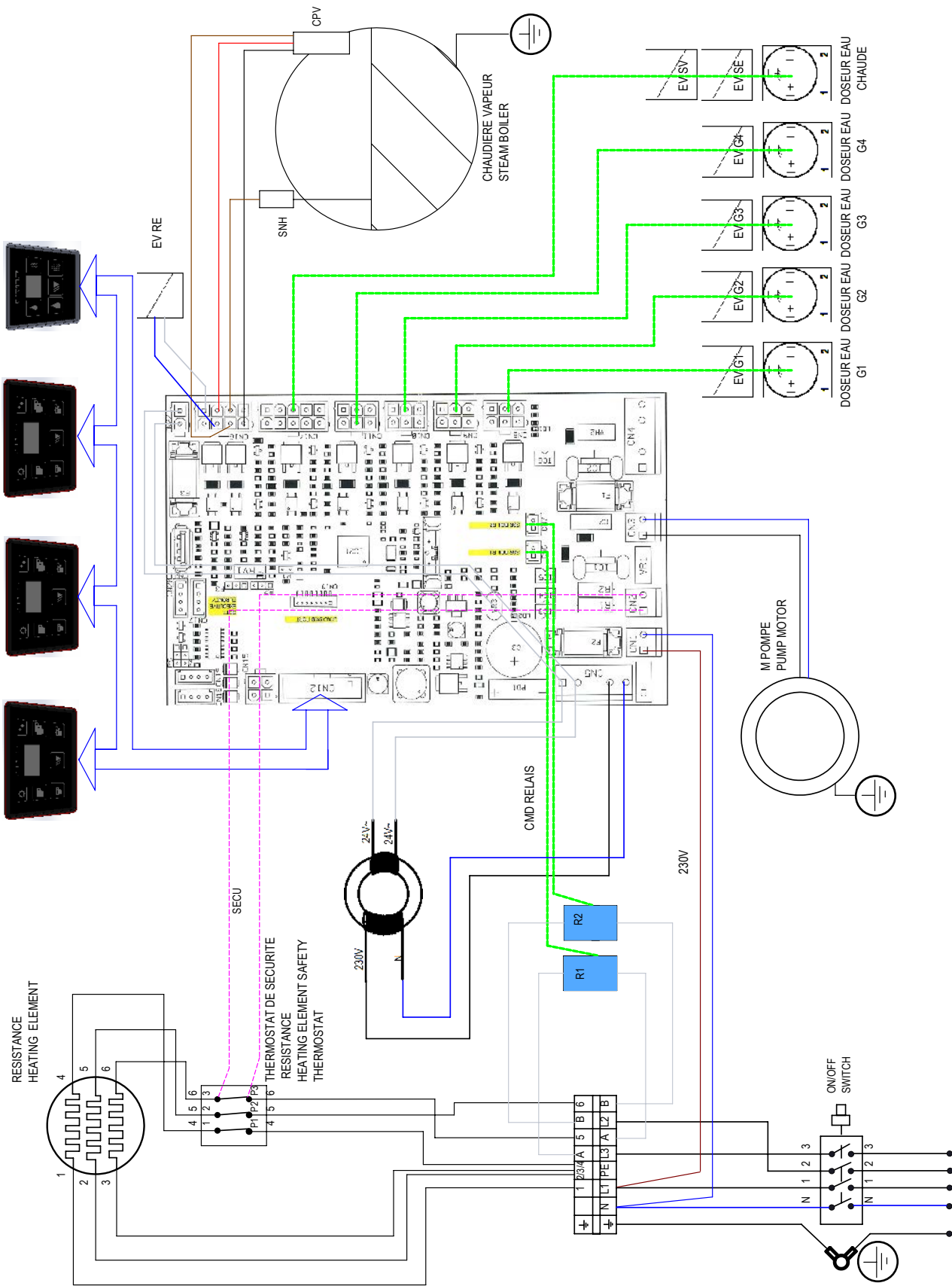

## 2-USE & PROGRAMMING

### ► Presentation of the various keyboards

#### ◆ 4 doses keyboard

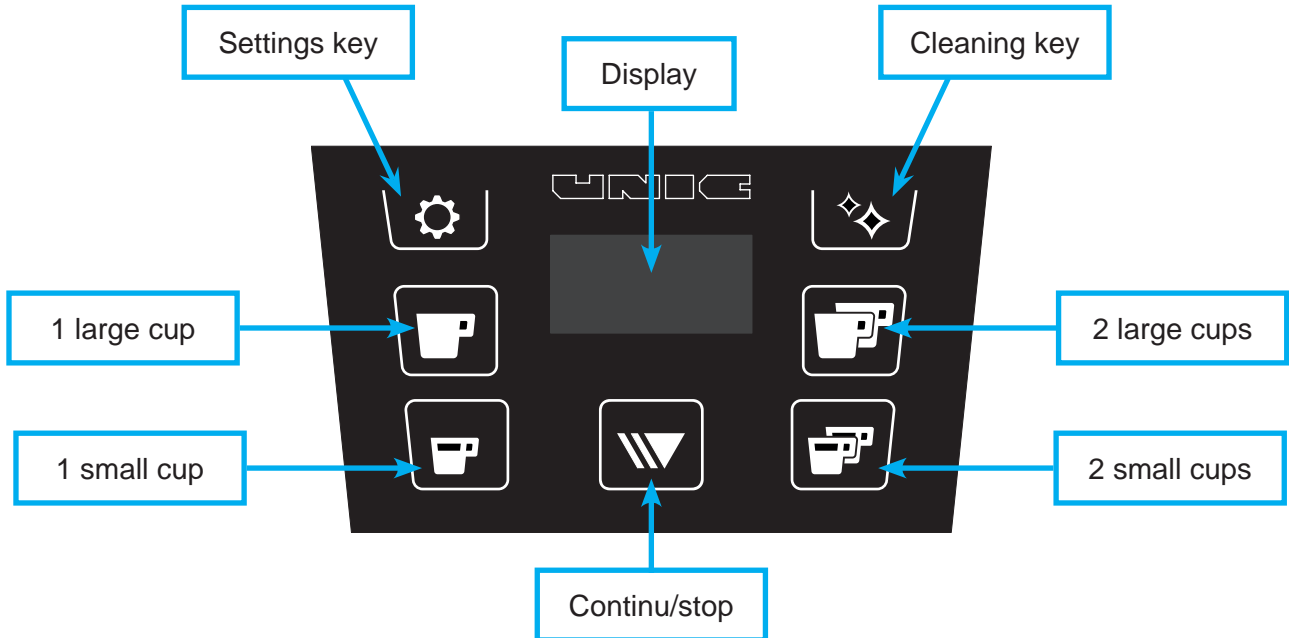

#### ◆ Dosamat keyboard

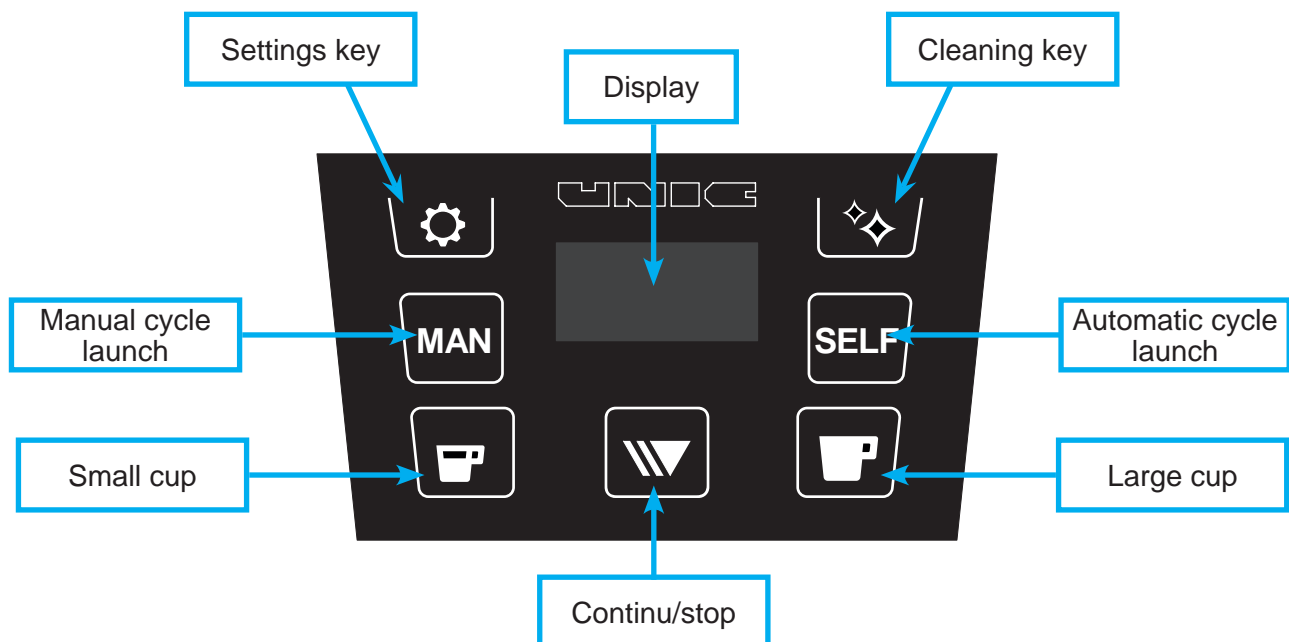

◆ Hot water & steam keyboard

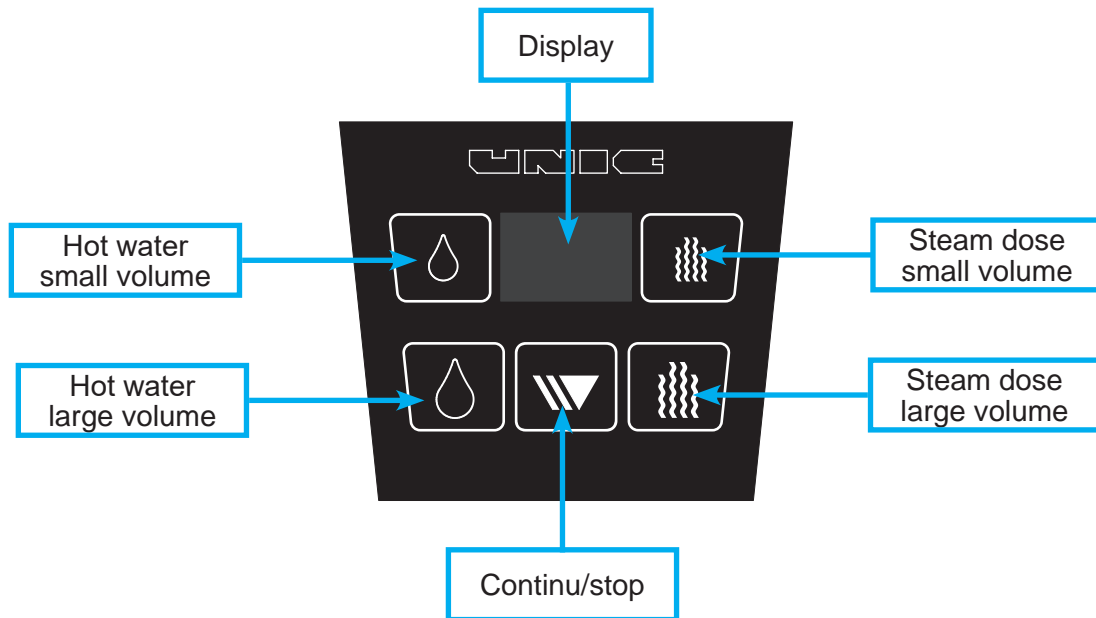

◆ steamAir keyboard

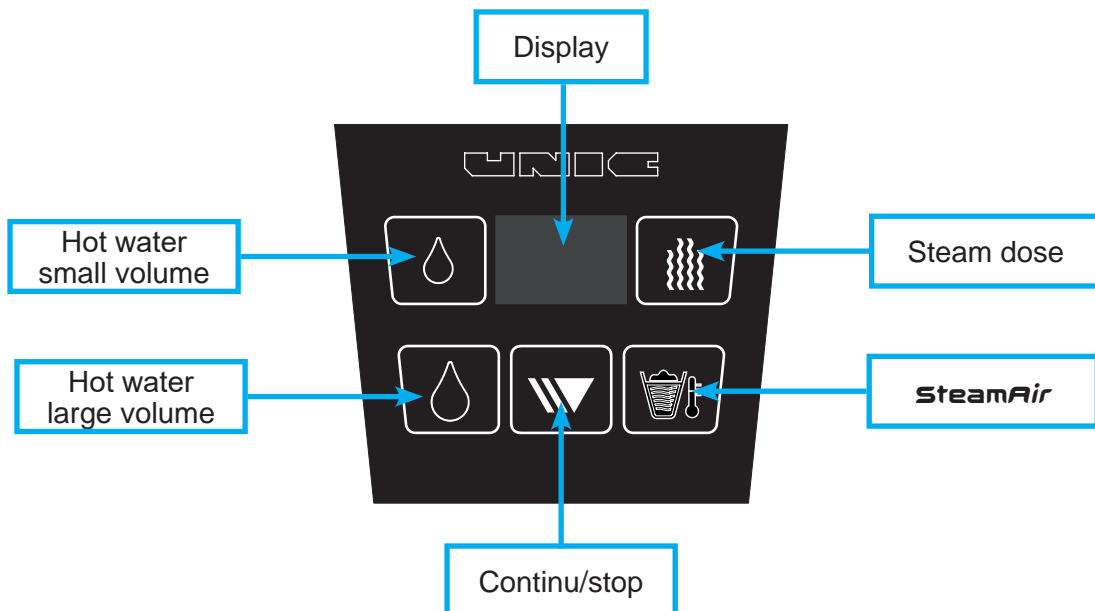

### ◆ Key operation

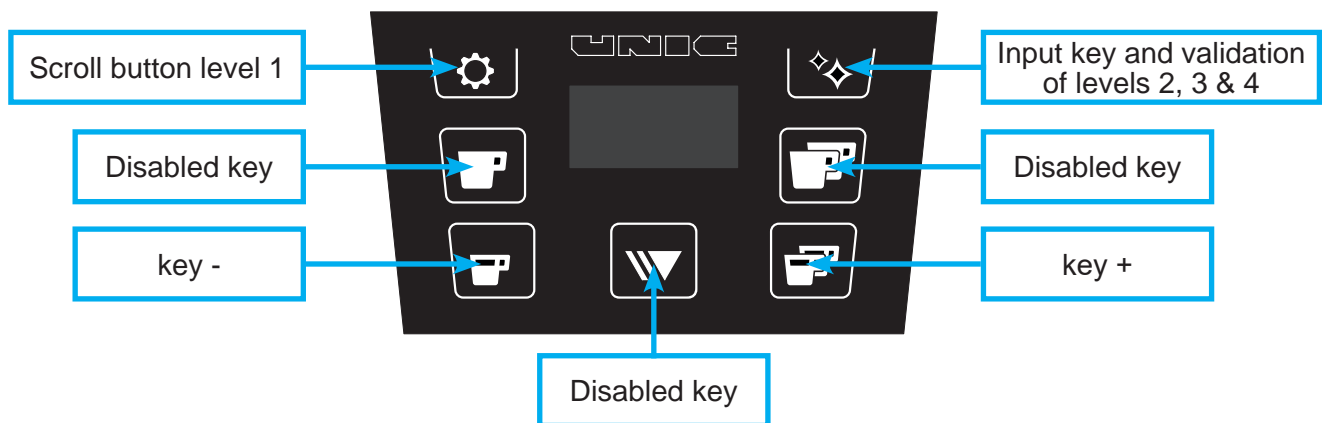

### ◆ Setting default

	Coffee box		Factory settings
Independent on each group	1	<b>do</b> coffee doses	1 small cup = 42 ml 1 large cup = 65 ml 2 small cups = 84 ml 2 large cups = 130 ml
Common, only on GR1	2	<b>PrS</b> Steam pressure	1 bar (0.1MPa)
Independent on each group	3	<b>net</b> Cleaning	ON = 150 cycles
Common, only on GR1	4	<b>ECL</b> Lighting LED	Automatic
Common, only on GR1	5	<b>ect</b> Cup warmer	OFF
Group 1 = master	6	<b>CH</b> Chronometer	OFF
Group 1 = master	7	<b>Pr</b> Pre-infusion	Pri ON = 0 Pri OFF = 0
Group 1 = master	8	<b>dos</b> Dosamat	OFF
Group 1 = master	9	<b>cts</b> Continu/stop key	ON
Independent on each group	10	<b>rin</b> Rinsing barista	OFF
Common, only on GR1	11	<b>doE</b> Hot water dosing	OFF
Common, only on GR1	12	<b>StA</b> <b>SteamAir</b>	ON
Common, only on GR1	13	<b>inf</b> Paiement system	OFF
Common, only on GR1	14	<b>cty</b> Tactile setting	0
		Service box	Factory settings
	1	Hot water small volume	10s
	2	Hot water large volume	20s
	3	Steam small volume	10s
	4	Steam large volume	20s
	5	<b>SteamAir</b>	62°C (143.6°F)

### ◆ Different levels of menus

	Level 1	Level 2	Level 3	Level 4
1	coffee doses		Dose adjustments	
2	Steam pressure	Setting 0.5 to 1.5 bar 0.05 to 0.15 MPa		
3	Cleaning		Setting 20 to 999 cycles	
4	Lighting LED			Setting 0 to 256
5	Cup warmer		Setting 60 to 100°C / 140°F to 212°F	
6	Chronometer			
7	Pre-infusion		Setting 0 to 2.5s	
			Setting 0 to 2.5s	
8	Dosamat		 	Setting 0 to 9s
9	Continu/stop key			
10	Rinsing barista	Setting 0 to 4s		
11	Hot water dosing			
12	SteamAir			
13	Paiement system			
14	Tactile setting			
		Setting 0 to 2		

### ◆ Access to parameter

Double authentication to enter in setting :

*Nota: Possibility to block the programing by jumper on CPU on P1 jmupe*

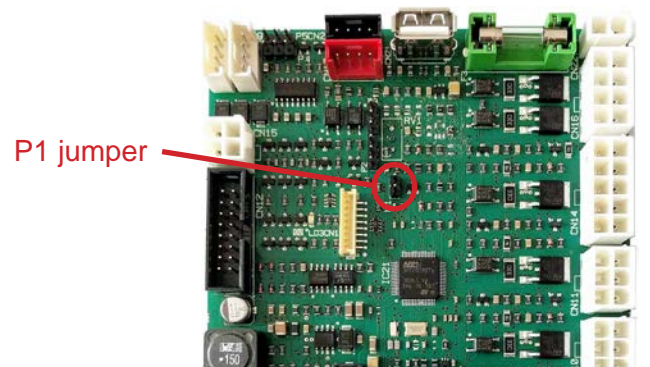
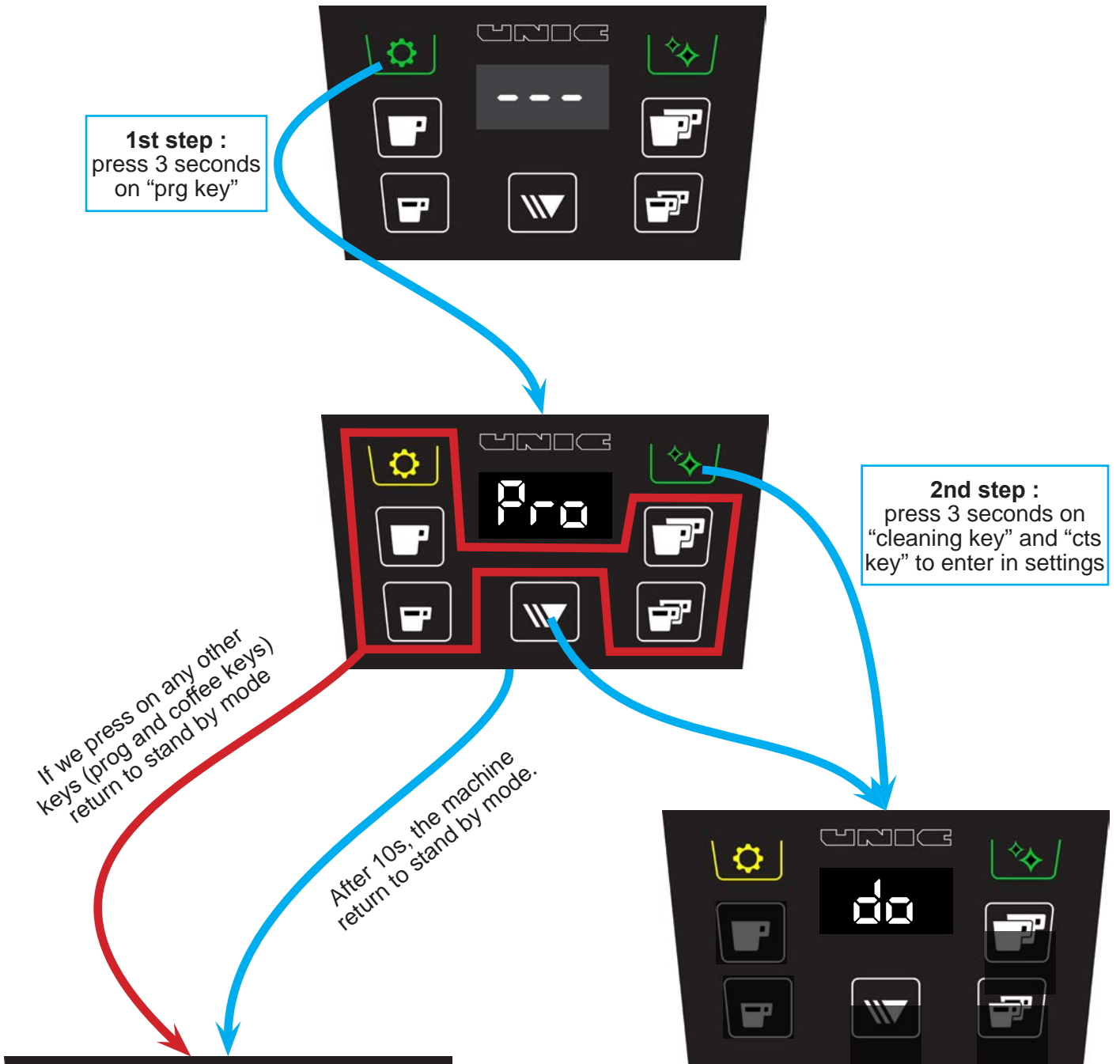

◆ *The menu tree*

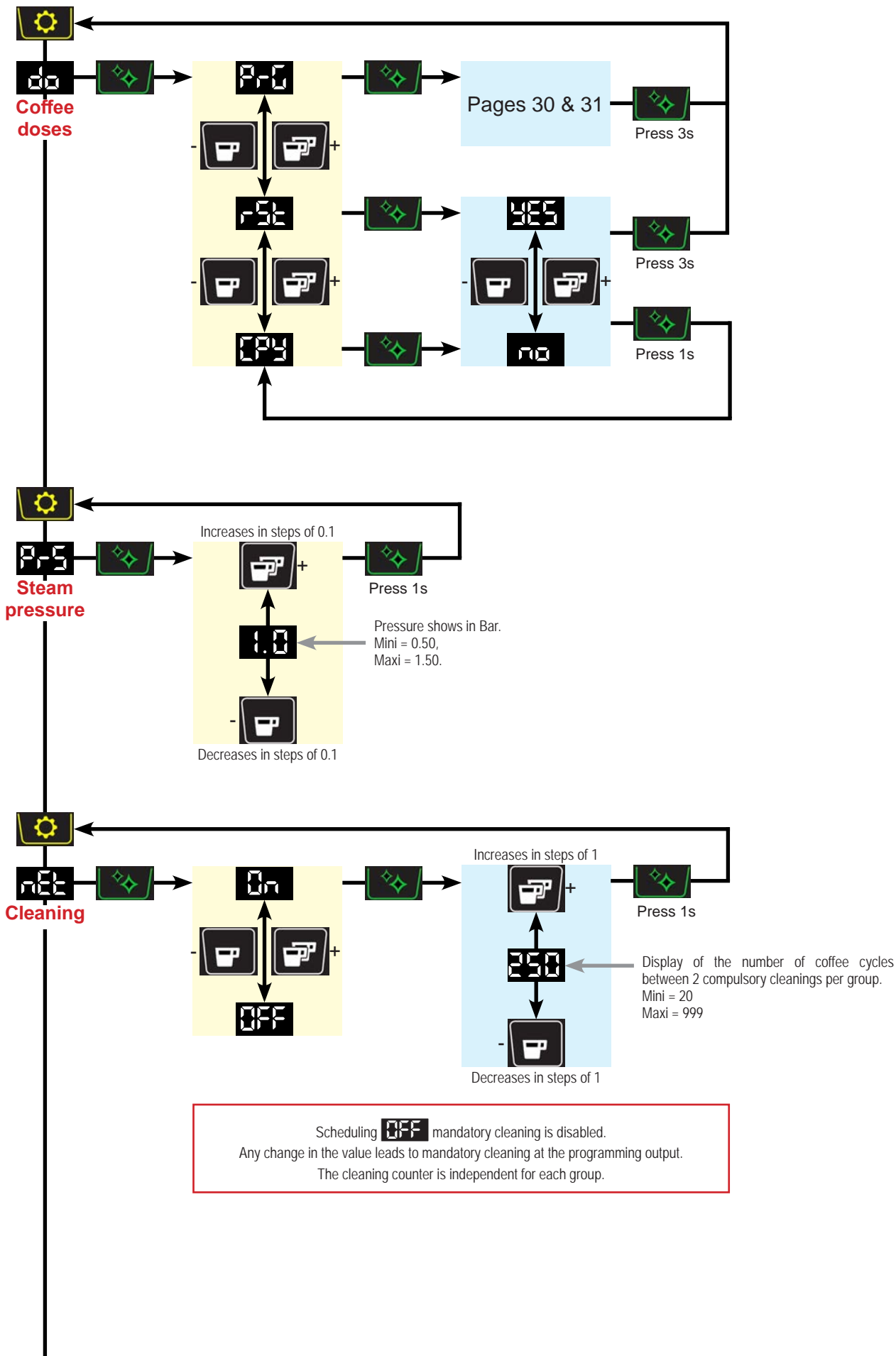

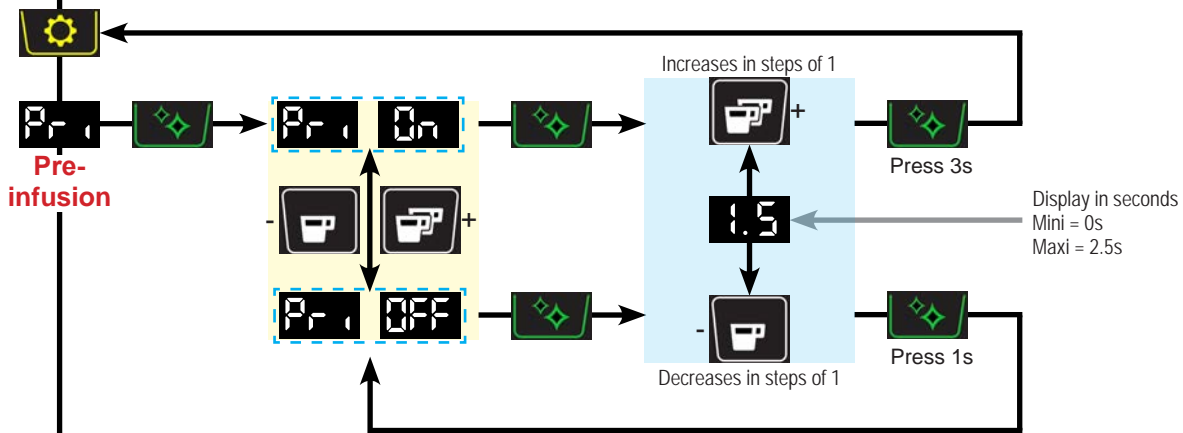
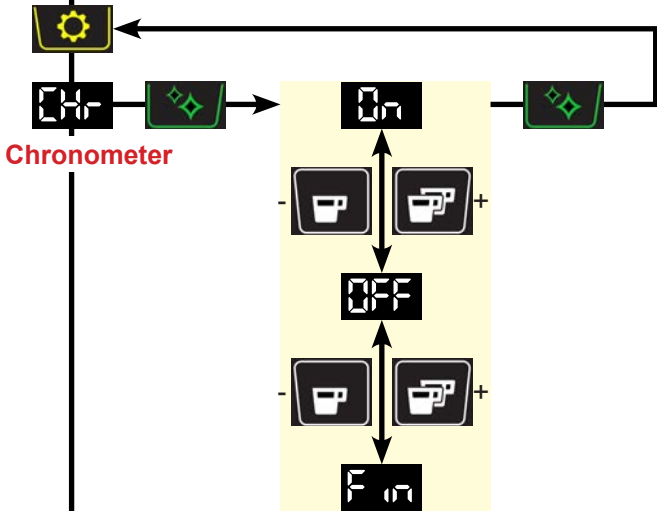
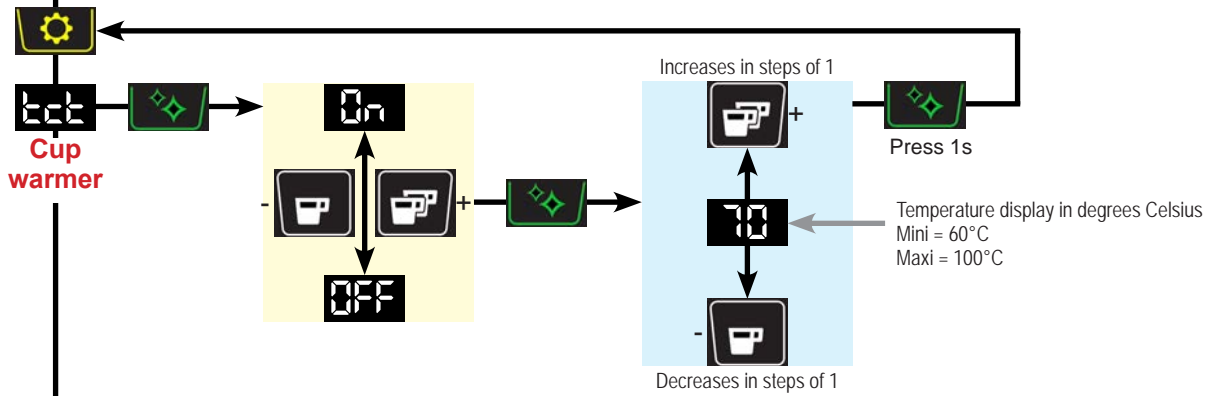
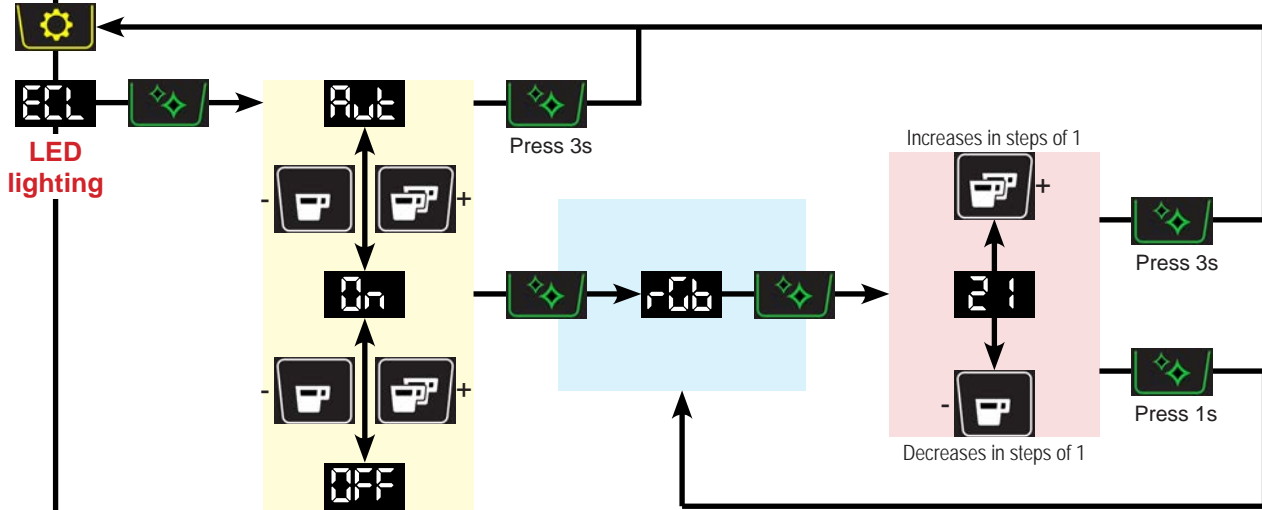



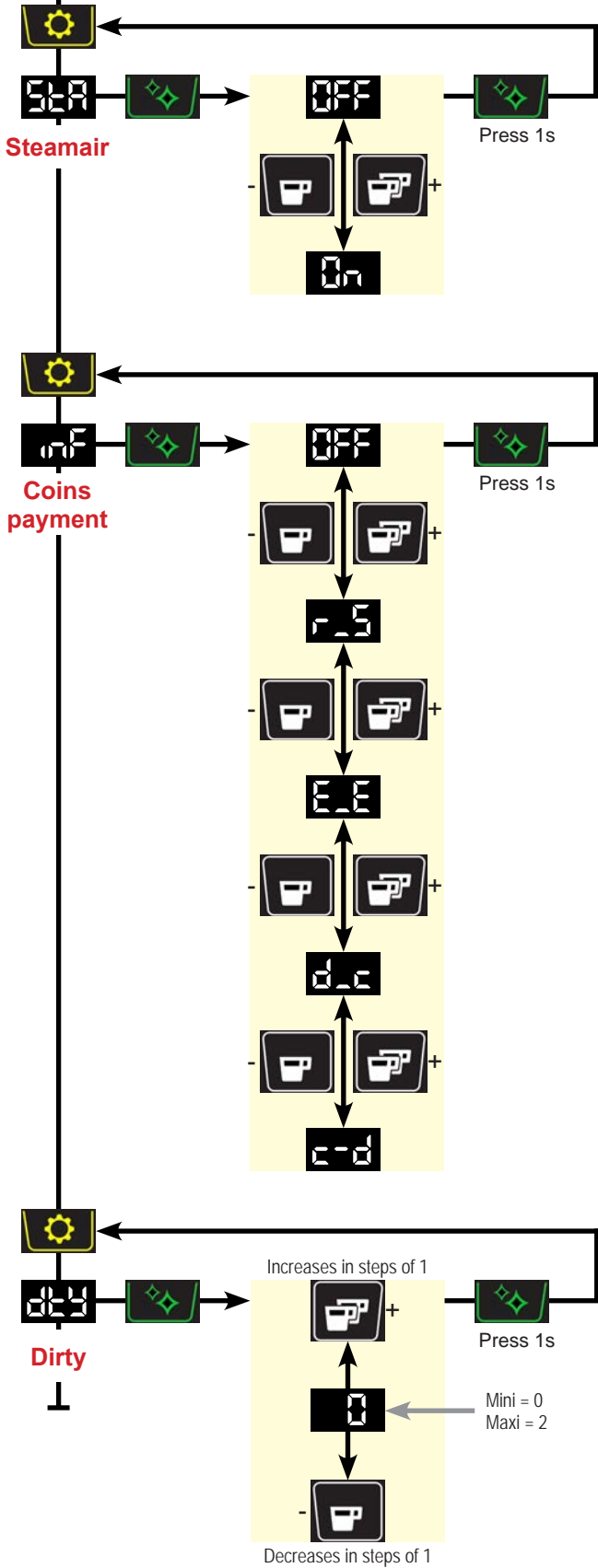

## ► PROGRAMMING THE DIFFERENT VOLUMES OF COFFEE

### ◆ Electronic box

#### ◆ Use

An impulse on the key    and  activates the corresponding flow delivery. During cycle, the display shows the remaining time in seconds. To stop before the end of the delivery, press again the same key.

*Note: a safety stops the flow after 105 seconds for the water and after 180 seconds for the steam.*

#### ◆ Programming

The electronic box enter automatically in programming (blinking keys), when we press 3 seconds on the "programming key"  of coffee boxes.

The programming mode













Programming mode allows you to set the hot water and steam doses (time) :

- Place a container under the outlet and press the key to be adjusted.
- When the level in the container is correct press the same key again.
- Press on key  of coffee boxes, to confirm new settings and exit programming mode.

### ◆ Dosamat box

















The dosamat box detects the number of cups when the filter holder is switched on, it is therefore imperative to make the settings with the different cups (1 cup and 2 cups).

1	Press 3 seconds on the key  to enter in programming mode
2	Menu  appears, press on the key 
3	The sub-menu  appears, press on the key  (All keys blinking)
	The keys    are programmable
Example with the key  and a filter holder 2 cups:	
4	Pack the ground coffee in the filter holder
	Snap the filter holder on the group
	Press the key  , to start de coffee cycle (volume not shown)
	When the volume is correct, press again on the key  to stop the cycle
Repeat the same process for other doses (large volume & different filter holder)	
5	Once all the doses have been programmed, confirm the programming by pressing 3 seconds on 







### ◆ 4 doses box



1	Press 3 seconds on the key  to enter in programming mode
2	Menu  appears, press on the key 
3	The sub-menu  appears, press on the key  (All keys blinking)
	The keys      are programmable
Example with the key  :	
4	Pack the ground coffee in the filter holder
	Snap the filter holder on the group
	Press the key  , to start de coffee cycle (volume shown in millimeter during cycle)
	When the volume is correct, press again on the key  to stop the cycle
	Repeat the same process for other doses
5	Once all the doses have been programmed, confirm the programming by pressing 3 seconds on 

### ◆ Copy setting between coffee boxes

The programming is independent on the coffee boxes, it is possible to copy the dose settings from one box to another, using the copy function .

- After the programming doses on group 1, go to the sub-menu , select  to execute the copy of the doses, then confirm by pressing the key  (all keys blinking).
- Go to another coffee box (ex: group 2) select the sub-menu Gr1 then select  to confirm the transfer of data to group 2, press the key , all keys blinking to indicate the validation of the copy.
- To exit, press on the key of programming  during 3 seconds, on one of the groups of the machine.

### ◆ Reset to factory values

At the starting of the machine, when the boxes shows the version (example «2.80») Press on the 3 keys (as shown opposite) until the display shows «PRE».

Restart the machine to validate the values.



### ◆ Option steamAir

The **SteamAir**  option allows, particularly when making cappuccino, to foam the milk very easily and automatically: the supply of air mixed with steam brings milk to a programmed temperature 60° to 70° (140°F to 158°F) and foams it.

The stop is done automatically when the temperature is reached which saves milk from boiling. By this way the milk qualities are preserved.

Once the air/steam adjustment is defined, the operation is as follows:

- Insert the **SteamAir** outlet into the milk container

- Push on the **SteamAir** key

Wait for it to stop automatically.

The **SteamAir** box also controls a timed steam and hot water outlet

### ◆ Components

- Wipe the steam wand with a clean towel after each use.

- Purge the wand after each use with a short burst of steam.

- Remove and clean the steam tip, outer wand and temperature probe at least once per day.

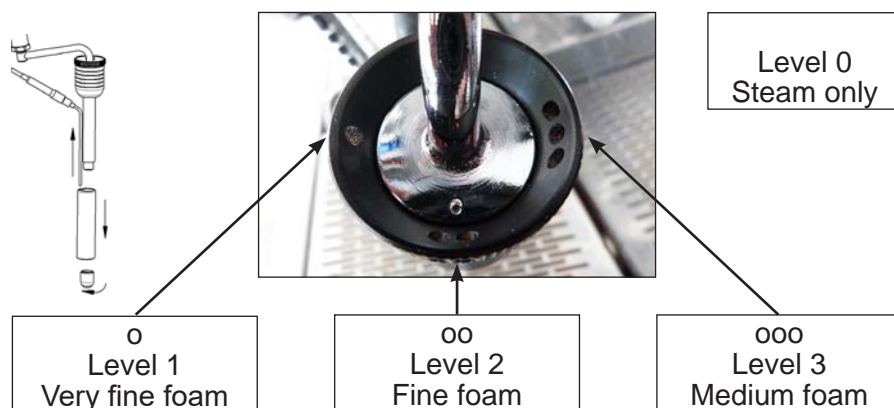

### ◆ SteamAir key

- Automatic mode: (To reach the programmed T°)

One impulse on the key makes the **SteamAir** flow until the liquid reaches the preset temperature (You can stop it manually by pushing again on the key).

- Manual mode: (Over the programmed T°)

If after the stop in automatic mode (temperature reached) you wish to continue the heating, you have to press again the key.

Then you go into manual mode and the outlet is again activated.

To stop you will have to push again on the same key.

If you don't do it, it will be stopped automatically by one of the two safeties: after 180 seconds or when the liquid temperature reaches 96°

### ◆ SteamAir temperature adjustment

-The steam tip must be at least 1" below the surface of the milk.

- Press the button with the **SteamAir** key The milk probe temperature is displayed on the screen. (Use a separate thermometer for more accuracy).

- Re-press the button when the desired temperature is reached

- The new value is saved automatically.

*Note: The temperature adjustment can be done in a range of 50°C to 90°C (122°F 194°F). The default is 62°C (143.6°F).*

Once all settings, exit the programming mode to validate the settings.

## ► Cleaning

REMEMBER TO CHECK THE WATER TREATMENT SYSTEM PERIODICALLY.

DO NOT USE ABRASIVE CLEANERS SCOURING PADS.  
DO NOT USE CLEANERS CONTAINING BLEACH.

THE DESCALING OF THE MACHINE MUST BE DONE BY A QUALIFIED TECHNICIAN.

WARNING: The air must circulate freely around the machine. The ventilation openings on the rear of the machine and on top must not be obstructed.

### ◆ Reference of cleaning tools:

UNIC Reference Puly caff: 92040

UNIC Reference support: RB0100

Note: for more information on cleaning products, refer to the manufacturer's safety data sheet

### ◆ After each use

#### ◆ Steam output tube:

After each use, clean the steam outlet with a damp cloth and release steam for a short time to eliminate the small residue of milk which has been able to remain in the tube.  
(Remove the tip of the steam pipe for easier cleaning).

### ◆ Daily

#### ◆ Before use or after several hours of inactivity:

Drain:

- by each unit and water outlet 0.5 litre of water.
  - by each steam outlet of the steam for 1 minute.
- "BEFORE PREPARING A DRINK"

#### ◆ After the service :

- Take the 2-cup filter holder cup.
- Place the rubber plug (Ref. DO-197) inside the filter.

Rinsing the decompression circuit:

- Engage the cup on the unit by tightening it.
- Press a coffee key to pressurize the cup, and then stop the unit. Repeat the operation several times by emptying the water contained in the cup each time.

Rinsing the cup seal:

- Engage the cup on the unit without tightening it.
- Press a coffee key by tightening and loosening the cup alternately, to create a leak at the level of the seal to clean it.

### ◆ Weekly

#### ◆ Filter holder cup

Clean the filter holder cups and filters (by taking the filter out of the cup) with washing powder.

#### ◆ Basin

Remove the basin - top of basin assembly, and clean each component in your sink.

#### ◆ Bodywork

Use a soft cloth and alcohol for the parties in stainless steel, and non-abrasive detergent for painted parts.

### ◆ Cleaning coffee groups

3 different situations:

#### **Pre alert**

At 130 coffee default  
The light become yellow



#### **Group blocked**

At 150 coffee default  
The light become red





#### **Cleaning mode**

Press the cleaning touch to enter in cleaning mode.



*Note : the cleaning key become yellow when there are 20 coffee left before compulsory cleaning.*

#### ◆ Launching of cleaning after group blocked:

- Press the cleaning touch  (it turns blinking blue).
- Put a detergent pellet above the rubber plug (ref. DO197) then insert and tighten the filter-holder in the unit.
- Press the key continu/stop  to launch the cleaning cycle (2s ON / 8s OFF x 10 sequences).  
Display nP (cleaning)
- When the display shows rP: take off the filter-holder from the unit and wait the end of the rinsing cycle (3x 30 seconds)
- At the stop of the automatic cycle: put back the filter holder without the plug and without coffee then start a 2 large cups cycle  to rinse it

#### ◆ Launch of cleaning Volunteer:

- Press the cleaning touch  for 3 seconds (it turns blinking blue when entering cleaning mode).
- Then follow the same instructions for cleaning after blocking.

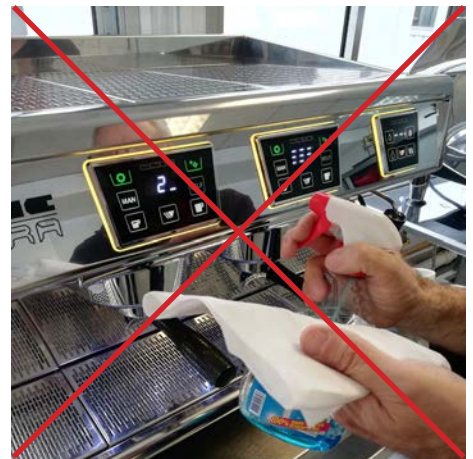

## ◆ Keyboards cleaning

**NEVER CLEAN KEYBOARDS WITH LIQUID WHEN THE MACHINE IS IN NORMAL OPERATION**



To clean keyboards, there is 2 process :

### 1<sup>st</sup> process :

1. Enable the function «keyboards cleaning» press simultaneous on the keys  &  during 1.5 s on left keyboard (all boxes are inactive)
2. Clean the keyboards and the front panel with a smooth towel and an adequate cleaning product
3. When the cleaning is done, press during 1.5 s on the key  (blinking) to return to standby of the machine.



### 2<sup>nd</sup> process :

1. Turn OFF the machine by main switch (position 0)
2. Clean the keyboards and the front panel with a smooth towel and an adequate cleaning product
3. When the cleaning is done, turn ON the main switch (position 2).



## ► List of color LED

n° 0	n° 61	n° 122	n° 183	n° 244
n° 1	n° 62	n° 123	n° 184	n° 245
n° 2	n° 63	n° 124	n° 185	n° 246
n° 3	n° 64	n° 125	n° 186	n° 247
n° 4	n° 65	n° 126	n° 187	n° 248
n° 5	n° 66	n° 127	n° 188	n° 249
n° 6	n° 67	n° 128	n° 189	n° 250
n° 7	n° 68	n° 129	n° 190	n° 251
n° 8	n° 69	n° 130	n° 191	n° 252
n° 9	n° 70	n° 131	n° 192	n° 253
n° 10	n° 71	n° 132	n° 193	n° 254
n° 11	n° 72	n° 133	n° 194	n° 255
n° 12	n° 73	n° 134	n° 195	n° 256
n° 13	n° 74	n° 135	n° 196	
n° 14	n° 75	n° 136	n° 197	
n° 15	n° 76	n° 137	n° 198	
n° 16	n° 77	n° 138	n° 199	
n° 17	n° 78	n° 139	n° 200	
n° 18	n° 79	n° 140	n° 201	
n° 19	n° 80	n° 141	n° 202	
n° 20	n° 81	n° 142	n° 203	
n° 21	n° 82	n° 143	n° 204	
n° 22	n° 83	n° 144	n° 205	
n° 23	n° 84	n° 145	n° 206	
n° 24	n° 85	n° 146	n° 207	
n° 25	n° 86	n° 147	n° 208	
n° 26	n° 87	n° 148	n° 209	
n° 27	n° 88	n° 149	n° 210	
n° 28	n° 89	n° 150	n° 211	
n° 29	n° 90	n° 151	n° 212	
n° 30	n° 91	n° 152	n° 213	
n° 31	n° 92	n° 153	n° 214	
n° 32	n° 93	n° 154	n° 215	
n° 33	n° 94	n° 155	n° 216	
n° 34	n° 95	n° 156	n° 217	
n° 35	n° 96	n° 157	n° 218	
n° 36	n° 97	n° 158	n° 219	
n° 37	n° 98	n° 159	n° 220	
n° 38	n° 99	n° 160	n° 221	
n° 39	n° 100	n° 161	n° 222	
n° 40	n° 101	n° 162	n° 223	
n° 41	n° 102	n° 163	n° 224	
n° 42	n° 103	n° 164	n° 225	
n° 43	n° 104	n° 165	n° 226	
n° 44	n° 105	n° 166	n° 227	
n° 45	n° 106	n° 167	n° 228	
n° 46	n° 107	n° 168	n° 229	
n° 47	n° 108	n° 169	n° 230	
n° 48	n° 109	n° 170	n° 231	
n° 49	n° 110	n° 171	n° 232	
n° 50	n° 111	n° 172	n° 233	
n° 51	n° 112	n° 173	n° 234	
n° 52	n° 113	n° 174	n° 235	
n° 53	n° 114	n° 175	n° 236	
n° 54	n° 115	n° 176	n° 237	
n° 55	n° 116	n° 177	n° 238	
n° 56	n° 117	n° 178	n° 239	
n° 57	n° 118	n° 179	n° 240	
n° 58	n° 119	n° 180	n° 241	
n° 59	n° 120	n° 181	n° 242	
n° 60	n° 121	n° 182	n° 243	