

OPERATING INSTRUCTIONS

TEDDY™ 5L Mixer

CONTENTS:

GUARANTEE:.....	1
SAFETY:	1
INSTALLATION OF NEW MIXER:.....	1
CONNECTION TO POWER:.....	2
INTRODUCTION TO THE MIXER:	2
RECOMMENDED WORKING SPEEDS:.....	2
OPERATION OF THE MIXER:	3
MAXIMUM CAPACITY OF THE MIXER:	3
OVERLOAD:	3
CLEANING AND HYGIENE:.....	3
MAINTENANCE:.....	4
LIST OF ERRORS AND POSSIBLE SOLUTIONS:	4
MOUNTING OF ACCESSORIES:.....	4
RECOMMENDED SPEEDS FOR ATTACHMENT DRIVE:	4

GUARANTEE:

The guarantee does not cover faults resulting from faulty operation, overloading and lacking observance of directions of maintenance.

In case of complaints, please contact your supplier.

In case you want further information, please state machine type and serial number of the mixer.

Varimixer A/S reserves the right to change and improve the products without notice.



SAFETY:

The machine is a technical tool, and is intended solely for working purposes.

The constant noise level of the workplace of the operator is lower than 70 dB (A).

The safety of the user is achieved by:

- The mixer will only start when the upper part is lowered.
- The upper part can only be tilted up when the mixer is stopped.
- Protection from excess current, excess voltage and too low voltage.
- The mixer is provided with fixed safety guard.

	<i>The machine must only be used by persons aged 14 and over.</i>
	<i>The machine must be monitored while it is in operation.</i>
	<i>Putting your fingers in the bowl while the mixer is running may cause injuries.</i>

INSTALLATION OF NEW MIXER:

The following equipment is included:

- | | |
|--------------------|----------------|
| ✓ Cable | ✓ Hook |
| ✓ Bowl | ✓ Beater |
| ✓ Lid for the bowl | ✓ Whip |
| ✓ Filling skid | ✓ Splash guard |

Before taking the mixer into use, check that all parts are delivered.

Dimensions and weight

TEDDY incl. equipment:

- Net weight with equipment: 22,0 kg
- Outside dimensions of mixer: 462 x 240 x 400 mm

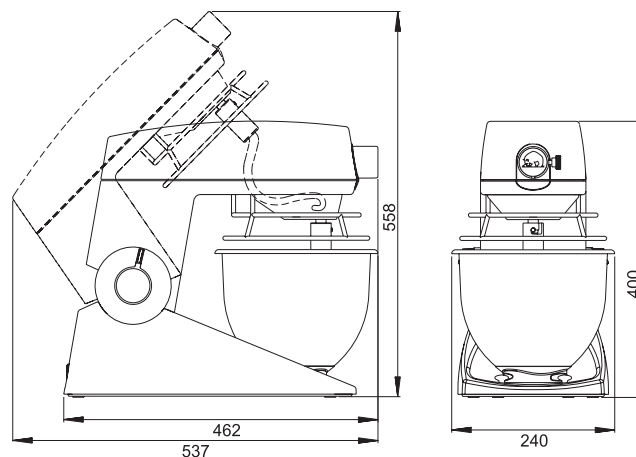

Location:

The mixer is to be placed on a stable and horizontal table.

™TEDDY is a registered trademark belonging to Varimixer A/S

Varimixer A/S

Kirkebjerg Søpark 6
DK-2605 Brøndby
Denmark

Phone: +45 43 44 22 88
info@varimixer.com
www.varimixer.com

CONNECTION TO POWER:



The enclosed cable must be used.

The mixer must be connected to earth!

- Only single phase power supply with earth must be used for the mixer. Use the enclosed cable.
- A plug with 2 pins + earth must be used.
- Check that the voltage of the power supply corresponds the voltage printed on the rating plate placed in the bottom of the mixer and stated on the packing.
- The mixer must be protected by a differential circuit breaker and a fuse of max. 10 A.
- A 2.5 amp fuse is built into the cable connector.

The power characteristics of the mixer:

Supply voltage (V)	Frequency (Hz)	Voltage (A)	Power consump. (W)
230	50/60	2,4	300
115	50/60	4,8	300

INTRODUCTION TO THE MIXER:

TEDDY is a small professional mixer for kneading, mixing and whipping in all environments where professional equipment is required.

Any operation of the mixer is made by means of the rotary buttons on the sides of the mixer. The two buttons can be used simultaneously or individually and are used both for start/stop, speed regulation and as opening/closing function.

The attachment drive **A** makes it possible to connect meat mincer.

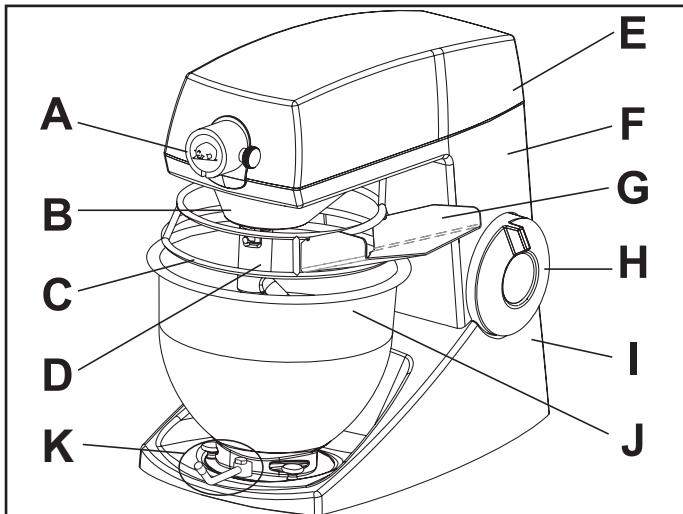

Fig. 1 The construction of the mixer

- | | |
|----------|--|
| A | Attachment drive, extra equipment |
| B | Housing of the planetary gear |
| C | Safety guard stainless steel |
| D | Bayonet shaft |
| E | Lid |
| F | Upper part |
| G | Filling skid |
| H | Control button (two pcs.) |
| I | Base |
| J | Bowl in stainless steel, contents 5 litres |
| K | Locking arm |

Equipment:

As standard the mixer comes with the following equipment:

- Bowl in stainless steel.
- White plastic lid for bowl
- Filling skid.
- Dough hook in stainless steel for kneading of dough.
- Beater in stainless steel for mixing.
- Whip in stainless steel for whipping.
- Splash guard in plastic.

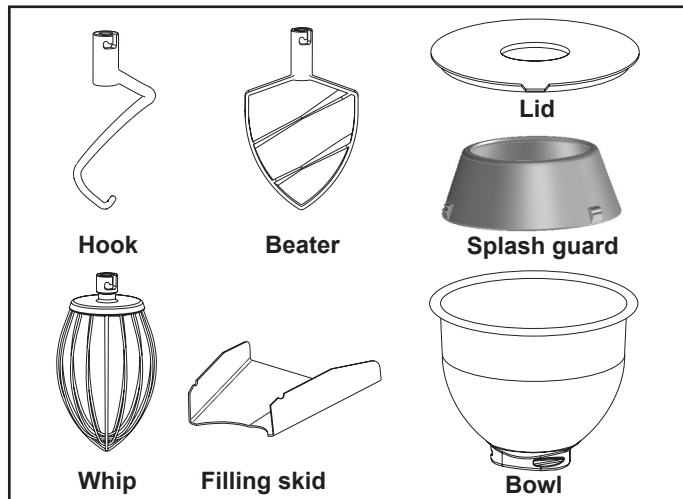

Extra equipment:

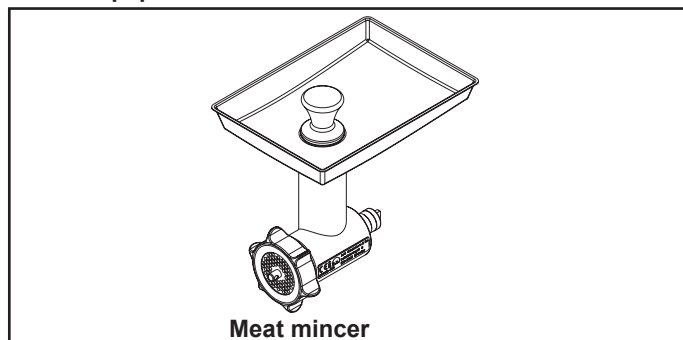

RECOMMENDED WORKING SPEEDS:

- Position 1-2: Low speed Kneading
- Position 1-3: Medium speed Mixing
- Position 1-5: High speed Whipping

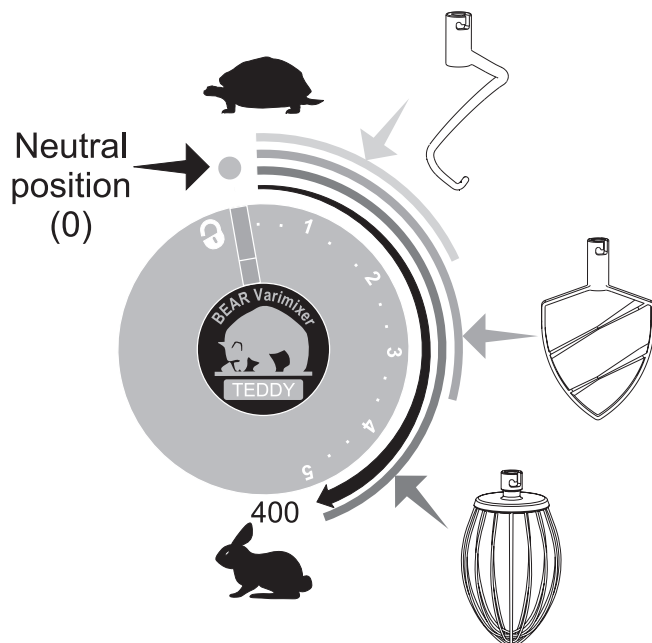

Fig. 2 Recommended working speeds

OPERATION OF THE MIXER:



The bowl must be mounted when the mixer is started!

The machine must be monitored while it is in operation

- A. Turn the control button to the locking symbol (fig. 3A).

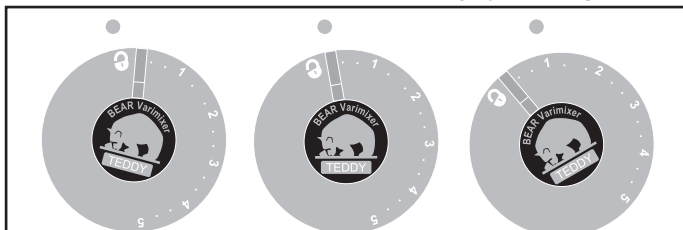

Fig. 3 The three positions of the rotary button.

- B. Tilt backwards the upper part of the mixer.
C. Place a tool in the bayonet shaft and turn it counter-clockwise to lock it in position (fig. 4).

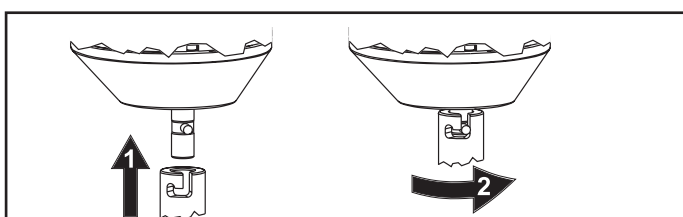

Fig. 4 Mounting of tool in the bayonet shaft.

- D. Place the bowl between the three locking bolts in the foot of the mixer and turn it clockwise until locked (fig. 5). Turn the locking arm anticlockwise to hold the bowl.

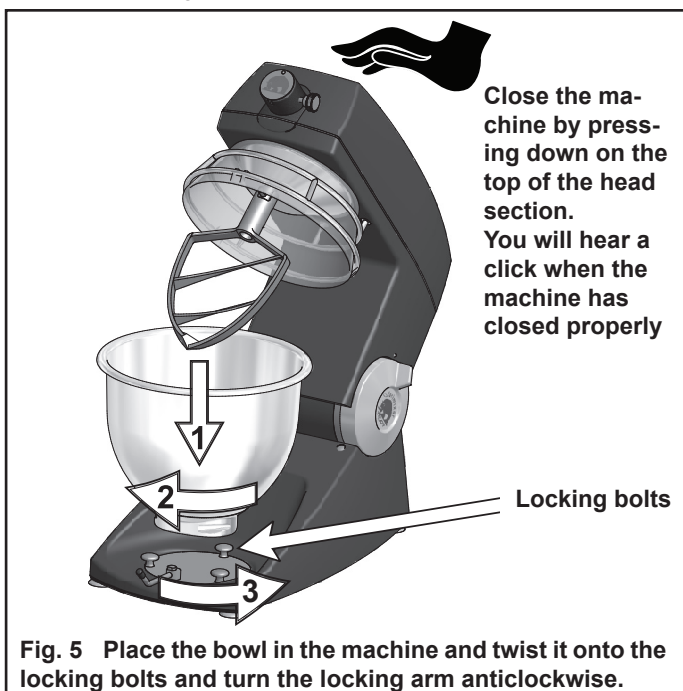

Fig. 5 Place the bowl in the machine and twist it onto the locking bolts and turn the locking arm anticlockwise.

- E. Fill the ingredients in the bowl.
F. Tilt the upper part of the mixer, including tool, down.
G. Start the mixer by turning the control button away from the locking symbol and past 1. To avoid splashing and dust from flour, it is recommended to increase the speed gradually until the required speed is obtained (fig. 3C), (see fig. 2 for recommended working speeds).
H. Stop the mixer by turning the control button back to neutral position (fig. 3B).
I. The upper part of the mixer can only be tilted backwards when the control button is turned to the locking symbol (fig. 3A).

3

MAXIMUM CAPACITY OF THE MIXER:

The working capacity of the mixer depends of:

- The tool used.
- Sort and quantity of the raw materials.
- The optimum speed for a good result.



Too big quantities will always reduce the quality of the product and the life of the mixer. Overloading can also result in sudden stops.

Product	Raw material	Approximate max. quality
Bread dough, 60%	kg dough	2,5
Flaky paste	kg dough	2
Wipped cream	l cream	1,5
Egg whites	no. of eggs	20
Sponge cake	no. of eggs	12
Meatball mix	kg	3

OVERLOADING:

If the mixer is moving e.g. kneading dough, this is **not** due to errors or overloading.

In case of overloading the electronic variator will reduce the current to the motor and stop it.



In case of stop due to overloading, turn the rotary button back to neutral position, and the mixer can be started again.

If the motor stops after long time of operation, and cannot be started immediately after, the thermosensor of the motor has switched off the current, and the mixer needs to cool down before it can be re-started. This protects the mixer from being destroyed.

The mixer contains two thermal cut-outs, which automatically reconnect in case of previous disconnection by the thermosensor.

CLEANING AND HYGIENE:

The equipment's ability to withstand the ingress of solid objects and water/fluids corresponds to IP42

After use:

- Remove bowl and tools.
- Wash the bowl and the tools in hot water and detergent / degreaser / disinfectant. Rinse with pure water and dry.



Do not spray water on the mixer

Tools and bowl can be cleaned in dishwasher.

- Wipe the housing of the planetary gear, the bayonet shaft and the safety guard. Use a damp sponge and a detergent / disinfectant. Rinse the parts with sponge and pure water.
- Check that the various parts have been cleaned thoroughly.
- Do not use abrasive detergents, which could scratch the surface.
- Use cleaning agents suitable for use on powder painted surfaces and plastic (polycarbonate).

MAINTENANCE:

The mixer requires no maintenance (motor and bearings for the mechanical parts are greased for life).

Safety device:

Check the function of the safety device regularly:

- The motor **must** stop when the rotary button is in neutral position (see fig. 3B).



If the safety device does not function, do not use the mixer. Contact your dealer.

LIST OF ERRORS AND POSSIBLE SOLUTIONS:



If the problem cannot be solved, contact your dealer.

The mixer does not start:

Check that ...

- The upper part of the mixer is in its down position.
- The mixer is plugged in and connected to power.
- The electrical power supply is correct.
- The fuse in the cable plug (fig.6, 1) has not been burned. If the fuse is defective, it can be replaced by the extra fuse (fig.6, 2) that is also available in the cable plug.

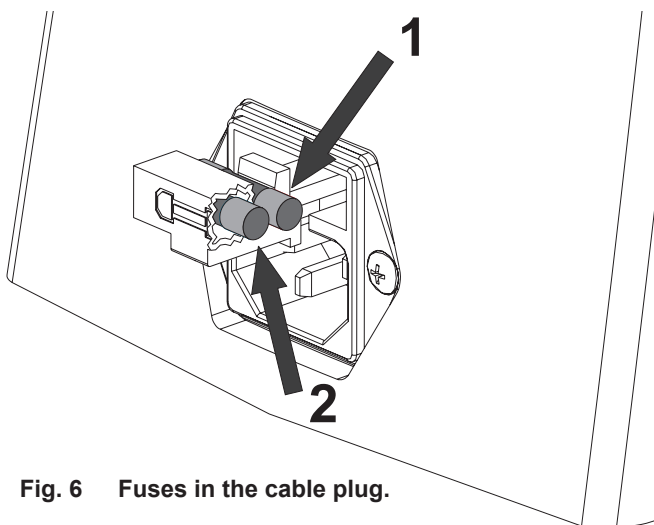

Fig. 6 Fuses in the cable plug.

The mixer stops during work:

- The mixer is overloaded due to too high speed or too heavy loading. See the paragraph "Overloading".



In case of power failure set the rotary button back to neutral position, and the mixer can be started again.

The tool is stuck in the bayonet shaft:

This is normally due to insufficient cleaning or damaged hole in the tool:

- Turn the tool backwards and forwards until it can be removed.
- Contact your distributor.

Unnormal noise:

Metallic noise ...

- The tool is distorted and hits the bowl.
- The bowl has been damaged or is not in its proper position.

MOUNTING OF ACCESSORIES:

The mixer can be equipped with an attachment drive with variable speed, and with the possibility of attaching the following equipment:

- Meat mincer Ø62 mm, supplied with meat tray, stamper and set of knives consisting of blade and plate Ø8 mm.



For further information regarding accessories, please see the special sheets following the accessories.

The mixer must always be disconnected before mounting or dismantling of the accessory.

Mounting of accessories (fig. 7):

- Assemble the accessory in question.
- Stop the mixer.
- Turn the cover plate C away from the hole.
- When mounting the pre-mounted accessory A, the shaft B is inserted into the attachment drive D of the mixer.
- By turning the accessory until the pin E is pointing towards the slot G a correct clutch is obtained.
- The accessory is pushed as far into the attachment drive D as possible. (The pin E must be in the slot G, then the shaft of the accessory is in a correct clutch with the attachment drive).
- The accessory is fastened by turning the star handle H clockwise.

Dismantling of accessories (fig. 7):

- Stop the mixer.
- Turn the star handle H counterclockwise until the locking screw is free of the hole F.
- Take out the accessory of the attachment drive, dismantle and clean it.

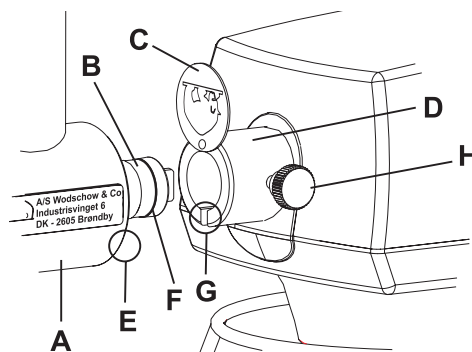

Fig. 7 Mounting of accessories.

RECOMMENDED SPEEDS FOR ATTACHMENT DRIVE:

