

**VULCAN®**

**INSTALLATION, OPERATING,  
SERVICE AND PARTS MANUAL  
FOR ELECTRIC COUNTER  
TILTING BRAISING PAN  
MODEL: VECTS12**

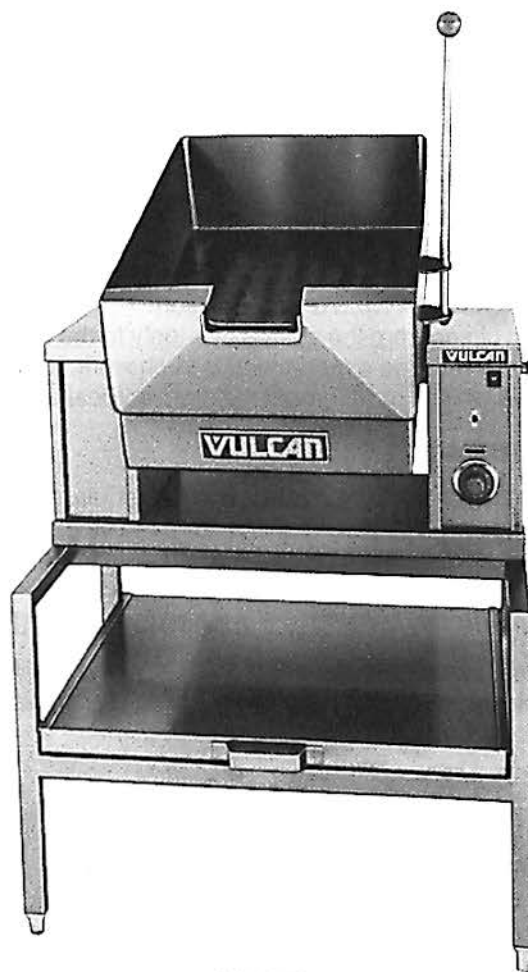

**VECTS12**  
Shown with optional stand and drain pan

Vulcan service agencies are located throughout the United States.  
For location and phone number of one near you, call your local Vulcan dealer.

VULCAN-HART CORPORATION, P.O. BOX 696, LOUISVILLE, KY 40201-0696, TEL. (502) 778-2791

# **IMPORTANT**

## **OPERATING, INSTALLING AND SERVICE PERSONNEL**

The operating information on this equipment has been prepared for use by qualified and/or authorized operating personnel.

All installation and service on this equipment is to be performed by qualified, certified, licensed and/or authorized installation or service personnel, with the exception of any part marked with a □ in front of the part number.

To obtain the name and location of an authorized Vulcan service agency, contact your Food Service Equipment dealer.

## **DEFINITIONS**

### **QUALIFIED AND/OR AUTHORIZED OPERATING PERSONNEL**

Qualified or authorized operating personnel are those who have carefully read the information in this manual and are familiar with the equipment's functions or have had previous experience with the operation of the equipment covered in this manual.

1. For the installation of gas piping from the outlet side of the gas meter, or the service regulator when the meter is not provided, and the connection and installation of the gas appliance, qualified installation personnel must be experienced in such work, be familiar with all precautions required, and have complied with all requirements of state or local authorities having jurisdiction. In the absence of local codes, installation must comply with National Fuel Gas Code ANSI Z223.1-latest edition.
2. For the installation of electrical wiring from the electric meter, main control box or service outlet to the electric appliance, qualified installation personnel must be experienced in such work, be familiar with all precautions required, and have complied with all requirements of state or local authorities having jurisdiction. In the absence of local codes, installation must comply with the National Electrical Code ANSI NFPA No. 70 latest edition.
3. For the installation of steam piping from the source of supply to the service inlet of the appliance, qualified installation personnel must be experienced in such work, be familiar with all precautions required, and have complied with all requirements of state or local authorities having jurisdiction.

### **QUALIFIED SERVICE PERSONNEL**

Qualified service personnel are those who are familiar with this equipment who have been endorsed by our company. All authorized service personnel are required to be equipped with a complete set of service and parts manuals and stock a minimum amount of parts for this equipment.

## **SHIPPING DAMAGE CLAIM PROCEDURE**

For your protection, please note that equipment in this shipment was carefully inspected and packed by skilled personnel before leaving the factory. The transportation company assumes full responsibility for safe delivery upon acceptance of this shipment.

### **If shipment arrives damaged:**

1. **VISIBLE LOSS OR DAMAGE** — Be certain this is noted on freight bill or express receipt and signed by person making delivery.
2. **FILE CLAIM FOR DAMAGES IMMEDIATELY** — Regardless of extent of damage.
3. **CONCEALED LOSS OR DAMAGE** — If damage is unnoticed until merchandise is unpacked, notify transportation company or carrier immediately, and file "concealed damage" claim with them. This must be done within fifteen (15) days of the date the delivery is made to you. Be sure to retain container for inspection.

We cannot assume responsibility for damage or loss incurred in transit. We will, however, be glad to furnish you with necessary documents to support your claim.

**PLEASE RETAIN THIS MANUAL FOR FUTURE REFERENCE**

# ELECTRIC COUNTER TILTING BRAISING PAN MODEL VECTS12 INSTALLATION, OPERATING, SERVICE AND PARTS MANUAL

## INDEX

Your Vulcan counter tilting braising pan is produced with quality workmanship and material. Proper installation, usage and maintenance will result in many years of satisfactory performance.

The manufacturer suggests that you thoroughly read this entire manual and carefully follow all of the instruc-

tions provided. Please retain this manual for future reference.

A data plate with the unit model number and serial number and the electrical characteristics that the unit requires is on the lower right outside corner of the console.

## DESCRIPTION

## PAGE

DEFINITIONS OF PERSONNEL (Operating, Installation and Service) and  
SHIPPING DAMAGE CLAIM PROCEDURE

(Inside Front Cover)

INDEX	3
DESCRIPTION	4
INSTALLATION	4
OPERATING	5
CLEANING	8
PARTS	8
WIRING DIAGRAMS	9-16

# DESCRIPTION

- A. The capacity of this tilting braising pan is approximately 12 gallons.
- B. The tilting braising pan is one of the most versatile pieces of equipment to be found in any restaurant or institutional kitchen.
- C. This unit will stew, simmer, pan fry, braise, grill and saute and all with a very uniform heat pattern. It cannot be used as a deep fat fryer.
- D. The tilting braising pan should always be preheated and allowed to cycle for more satisfactory results.
- E. A great deal of lifting and transferring of foods from one pan to another can be eliminated and, therefore, pot washing will be reduced.
- F. Frozen vegetables can be cooked in the braising pan in the serving pan, then removed and transferred directly to the serving line.
- G. The cover has a lip at the back edge which directs the condensate on the cover into the pan.
- H. The unit drains completely at full tilt.

# INSTALLATION

**WARNING: ELECTRICAL AND GROUNDING CONNECTIONS MUST COMPLY WITH APPLICABLE PORTIONS OF THE NATIONAL ELECTRICAL CODE AND/OR OTHER LOCAL ELECTRICAL CODES.**

## SET UP

- A. Check for the correct counter or stand position for the braising pan. Place it approximately 30" from the wall to the front of the pan. The pan should tilt easily.
- B. The surface for the braising must be level. Then secure the braising pan with the bolts that are provided.
- C. Seal the pan to the table top or stand with a high grade sealing compound.

## SERVICE CONNECTION

- A. All internal wiring of the braising pan was completed at the factory.
- B. Have a waterproof electrical connection from the incoming lines into the control box.
- C. Ground the braising pan to the terminal provided in the control housing.
- D. A wiring diagram is provided inside the control housing cover panel.
- E. All braising pans have been factory tested for control operation and for operation of the electrical heating elements.
- F. Check for proper operation.

## ELECTRICAL CHARACTERISTICS

MODEL	PH	208V		230V		240V		380V		415V		480V	
		KW	AMP	KW	AMP	KW	AMP	KW	AMP	KW	AMP	KW	AMP
VECTS12	1	9.0	43.2	9.0	39.1	9.0	37.5	—	—	—	—	—	—
	3	9.0	25.1	9.0	22.6	9.0	21.6	9.0	13.6	9.0	12.5	9.0	10.8

## CONTROLS

The controls on the braising pan are an "ON-OFF" electric switch and a thermostat. Turn the switch to "ON" when ready to start cooking. Dial the temperature control to bring the pan up to temperature and begin cooking. Do not leave the unit "ON" when not warming it up for cooking, or when nothing is being cooked. Turn the

unit "OFF" when through cooking. The pilot "ON" light lights when unit is turned on and the heating elements turn on. Use the thermostat to dial the correct temperature for the type of cooking being done. When the dialed temperature is reached the elements turn off. The elements continue to cycle off and on, holding the dialed temperature.

# OPERATING

**WARNING: DO NOT USE A BRAISING PAN FOR DEEP FAT FRYING. RESTRICT FRYING ACTIVITY TO SHALLOW PAN FRYING (OIL FILM NOT MORE THAN 1/8 INCH THICK) OR SAUTÉING. FAILURE TO FOLLOW THIS COULD RESULT IN A FIRE HAZARD.**

**WARNING: THE BRAISING PAN IS HOT. USE CARE WHEN OPERATING AND SERVICING THE BRAISING PAN.**

- A. Check that unit has been electrically connected and that circuit breakers are on.
- B. Turn the power switch to the "ON" position.
- C. Tilt the braising pan to check that it moves easily. Turn the handle as far as it will go and then return it to its upright position (approximately 90 degrees).
- D. Dial the thermostat dial to the temperature needed

- E. Preheat the unit for 5 to 7 minutes and allow it to cycle to equalize heat across the surface.
- F. When the optional cover is provided, use it to boil water faster and to reduce evaporation.
- G. When cooking is completed, return the thermostat to the "OFF" position, turn the power switch "OFF", remove the food, put water and detergent in the pan and let it soak, for easier cleaning.
- H. If the cooking oils or fat get too deep in the pan, drain off the excess by slightly tilting the pan and draining the fat into a container.
- I. Turn the thermostat down to hold food warm.
- J. Do not use sharp cooking or cleaning instruments. They can scratch the finish.

## OPERATING TIPS

- A: Sauces usually lose less moisture when the cover accessory is used.
- B. Frozen vegetables can be cooked in the braising pan,

Proofing	100°F .....	Thermostat Setting 1-2
Holding	150°-170°F .....	Thermostat Setting 2-3
Roasting	160°-200°F .....	Thermostat Setting 2-4
Simmering	Maximum of 200°F .....	Thermostat Setting 1-4
Sautéing	225°-275°F .....	Thermostat Setting 5-6
Searing	300°-350°F .....	Thermostat Setting 7-8
Frying	325°-375°F .....	Thermostat Setting 8-9
Griddling	350°-425°F .....	Thermostat Setting 9-10

- D. Temperatures of approximately 200°F should always be used for milk based products or scorching will take place. Lower temperatures (150°-175°F) prevent thickening.
- E. Breakfast foods such as sausage, bacon, pancakes, fried eggs, scrambled eggs and french toast are a few of the more common items cooked in this pan.
- F. When cooking meat or poultry, all pieces should be of fairly uniform size and weight and should be turned at least once while simmering.
- G. This unit can be used as a proof box by placing a

placed in a serving pan, then removed and transferred directly to the serving line.

- C. The following temperatures should be used:

small amount of water in the pan to form steam and then placing the food in another pan. The thermostat should be set very low (100°-150°F).

- H. It can be used as a holding cabinet by adding water and setting the thermostat at approximately 175°F.
- I. When cooking vegetables be sure to add water occasionally to keep level at about 3-4 inches. The thermostat should be set at 200°F.
- J. Perforated 2½" deep pans are suggested for vegetables for the most satisfactory results.

# THE VULCAN TILTING BRAISING PAN

The tilting braising pan is a very versatile piece of commercial cooking equipment. It can stew, simmer, pan fry, braise, griddle or saute with a very uniform heat pattern. The figures given below are suggested quantities, tem-

perature settings and estimated numbers of orders per load and per hour. When two temperatures are given, the first is to start the product, the second to complete the product.

ITEM	PORTION SIZE	THERMOSTAT SETTING	BATCHES PER HOUR
<b>BREAKFAST FOODS</b>			
Bacon	3 Slices	350°	12
Eggs			
Boiled-Hard	1 Egg	225°	5
Boiled-Soft	1 Egg	225°	8
Fried	1 Egg	400°	4
Poached	1 Egg	225°	5
Scrambled	1½ Eggs	300° 200°	1
French Toast	3 Slices	450°	7
Regular Oatmeal	½ Cup	250°	2
Pancakes	2 Each	400°	10
<b>FISH</b>			
Clams	1 pt.	400°	10
Fish Cakes	2 - 3 oz.	400°	5
Haddock Filet	4 oz.	400°	4
Halibut Steak	5 oz.	450°	3
Lobster	1 - 1 lb.	350°	4
Swordfish	5 oz.	450°	3
<b>SAUCES, GRAVIES, SOUPS</b>			
Brown Gravy	1 oz.	350° 200°	2
Cream Sauce	2 oz.	250° 175°	1
Cream Soup	6 oz.	200°	1
French Onion Soup	6 oz.	225°	1
Meat Sauce	4 oz.	350° 200°	1
<b>MEAT - POULTRY</b>			
Bacon	3 Slices	350°	12
Beef			
Chop Suey	6 oz.	400° 225°	2
Beef Stew	8 oz.	300°	--
Corned Beef Hash	5 oz.	400°	5
Cheeseburger	3 oz.	300°	12
Hamburger	3 oz.	300°	15
Meatballs	1 oz.	400° 225°	3
Pot Roast	2 oz.	350° 200°	--
Salisbury Steak	5 oz.	400°	3
Sirloin Steak	6 oz.	400°	5
Swiss Steak	4 oz.	300° 200°	1

ITEM	PORTION SIZE	THERMOSTAT SETTING	BATCHES PER HOUR
Chicken: Pan Fried	2 quarters	350°	3
Chicken: Whole	2 oz.	350° 200°	--
Hot Dogs: Grilled	2 oz.	300°	8
Hot Dogs: Boiled	2 oz.	250°	12
Ham Steak	3 oz.	400°	8
Pork Chops	5 oz.	350°	4
Sausage Links	3 links	350°	7
Turkey			
Off Carcass	2 oz.	400° 200°	--
On Carcass	2 oz.	400° 200°	--
<b>MISCELLANEOUS</b>			
Grilled Cheese Sandwiches	1 Sandwich	400°	8
Macaroni & Cheese	8 oz.	200°	2
Rice	4 oz.	350° 225°	1
Spaghetti	4 oz.	350° 225°	2
<b>VEGETABLES</b>			
Canned	3 oz.	400°	6
<b>FRESH</b>			
Beans, Wax, Green	3 oz.	400°	3
Beets	3 oz.	400°	1
Broccoli	3 oz.	400°	3
Cabbage	3 oz.	400°	5
Carrots	3 oz.	400°	2
Cauliflower	3 oz.	250°	5
Corn	1 Ear	400°	8
Potatoes	3 oz.	400°	2
Spinach	4 oz.	250°	10
Turnip	4 oz.	400°	2
<b>FROZEN</b>			
Beans, French Green	3 oz.	400°	6
Lima Beans	3 oz.	250°	4
Broccoli	3 oz.	400°	8
Sliced Carrots	3 oz.	250°	6
Small Whole Carrots	3 oz.	250°	3
Corn	3 oz.	250°	18
Small Whole Onions	3 oz.	250°	7
Peas	3 oz.	400°	10
Spinach	3 oz.	400°	3
<b>DESSERTS, PUDDINGS, SWEET SAUCES</b>			
Butterscotch Sauce	1 oz.	200°	1
Cherry Cobbler	3 oz.	200°	1
Chocolate Sauce	1 oz.	200°	1
Cornstarch Pudding	4 oz.	200°	1
Fruit Gelatin	3 oz.	250°	2

# CLEANING

---

The pan interior and exterior should be thoroughly washed after each use when a different food is to be cooked next or when cooking is completed for the day. Before cleaning check that the unit has cooled enough to touch it.

- A. Soak the cooking surface to remove any food stuck to the surface.
- B. Wash the pan surface with a mild detergent and warm water.

- C. Remove the wash water by tilting and draining it into a container.
- D. Check that the pouring spout, cover (optional) and sides of unit as well as the cooking surface are clean.
- E. Rinse the complete unit, then dry it.
- F. Never spray or pour water over the control console.

# PARTS

---

<u>Part Number</u>	<u>Description</u>
881970	Power Switch
840467	Thermostat
836832	Hi Limit Thermostat
881972	Pilot Light
*	Contactor
881985	Terminal Block
836834	Element Block Assembly 208V
836835	Element Block Assembly 240V
836836	Element Block Assembly 220/380V
836837	Element Block Assembly 480V
836838	Element Block Assembly 230V

\* Specify KW & Voltage

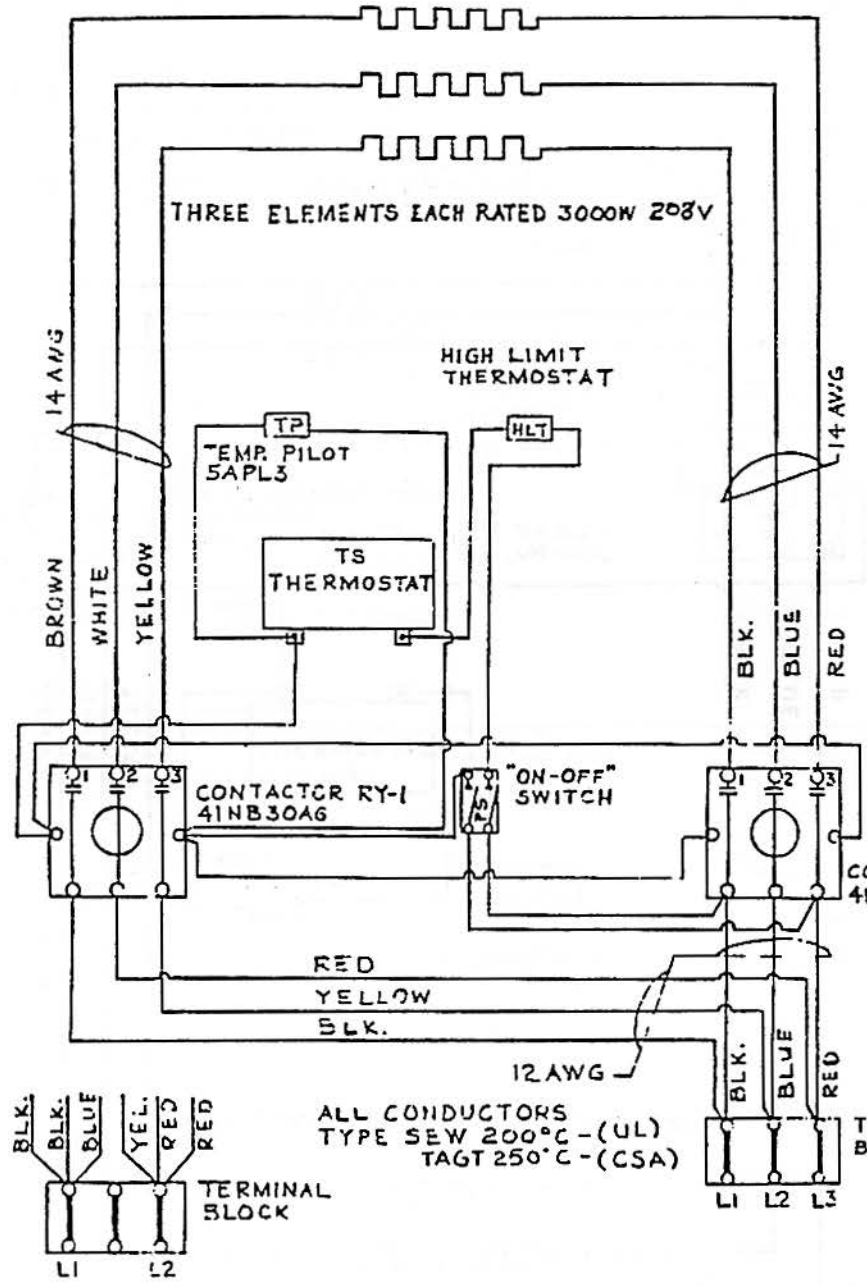

SINGLE PHASE CONNECTION

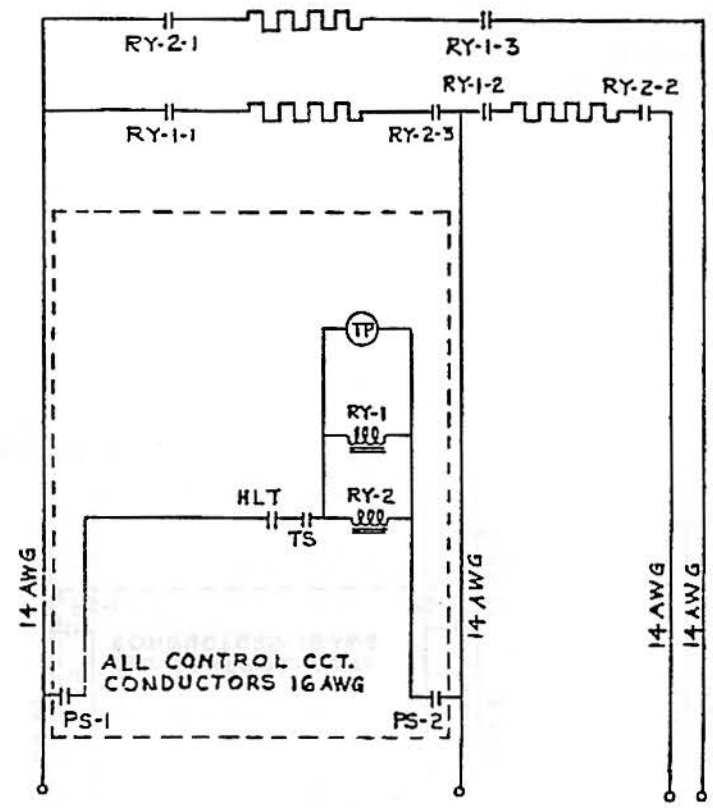

THREE PHASE CONNECTION

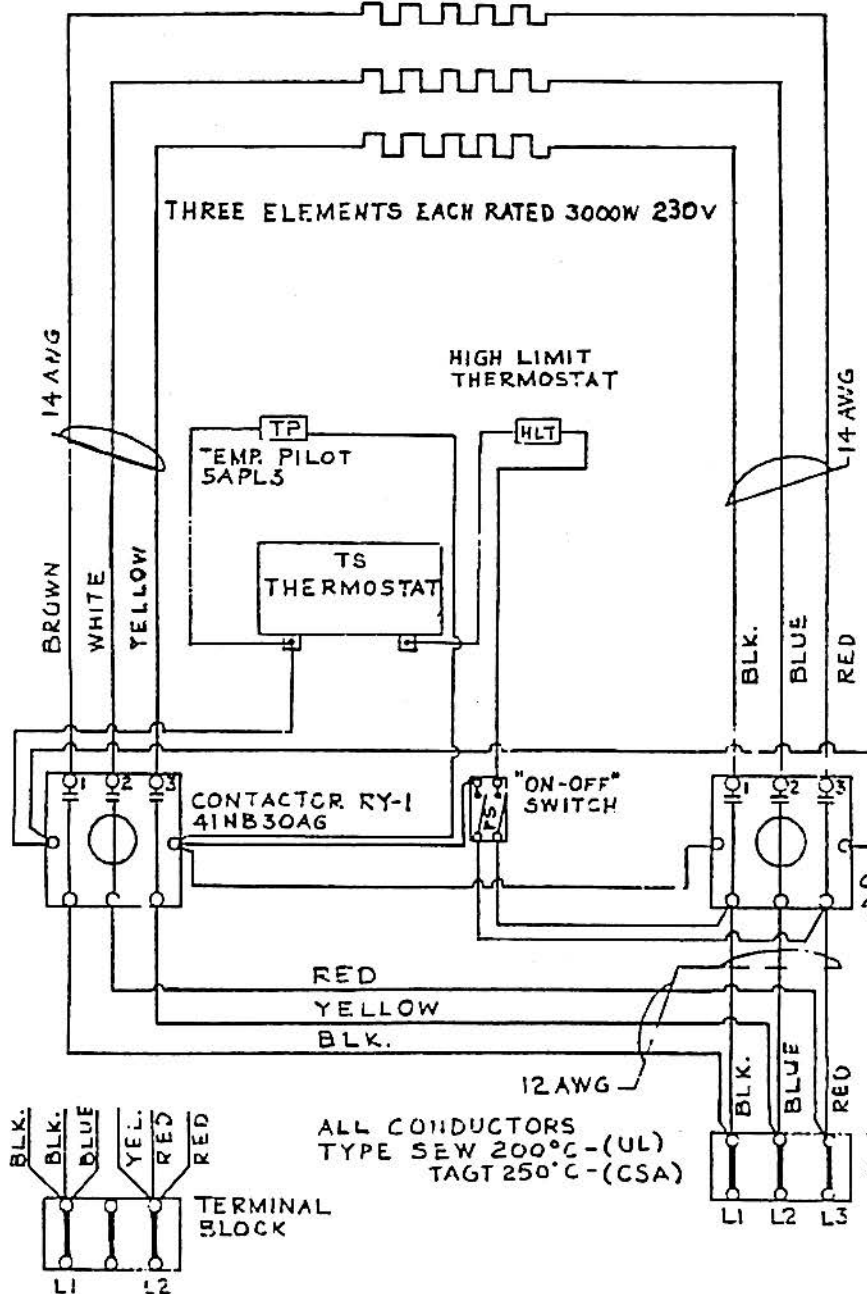

SINGLE PHASE CONNECTION

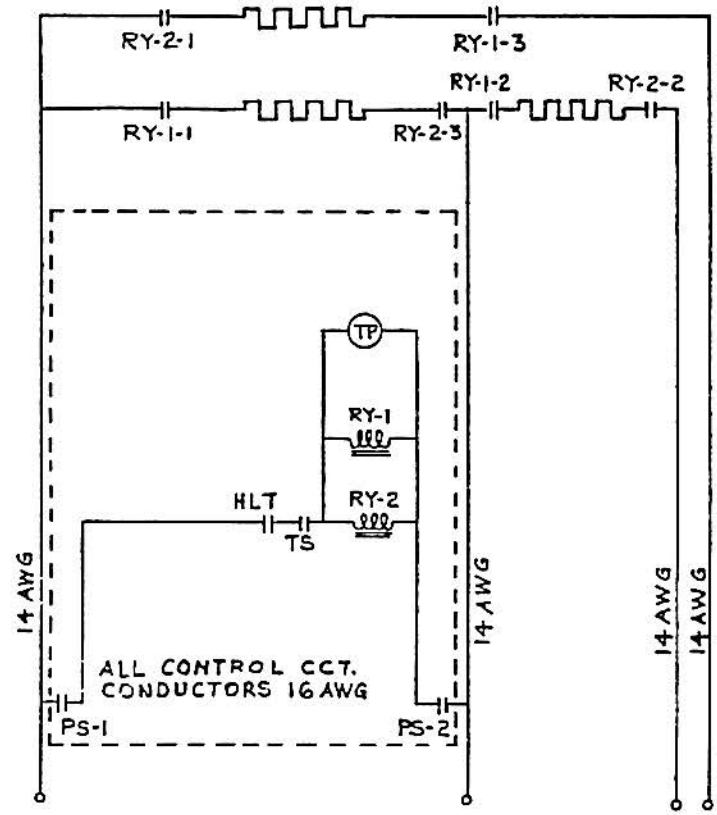

THREE PHASE CONNECTION

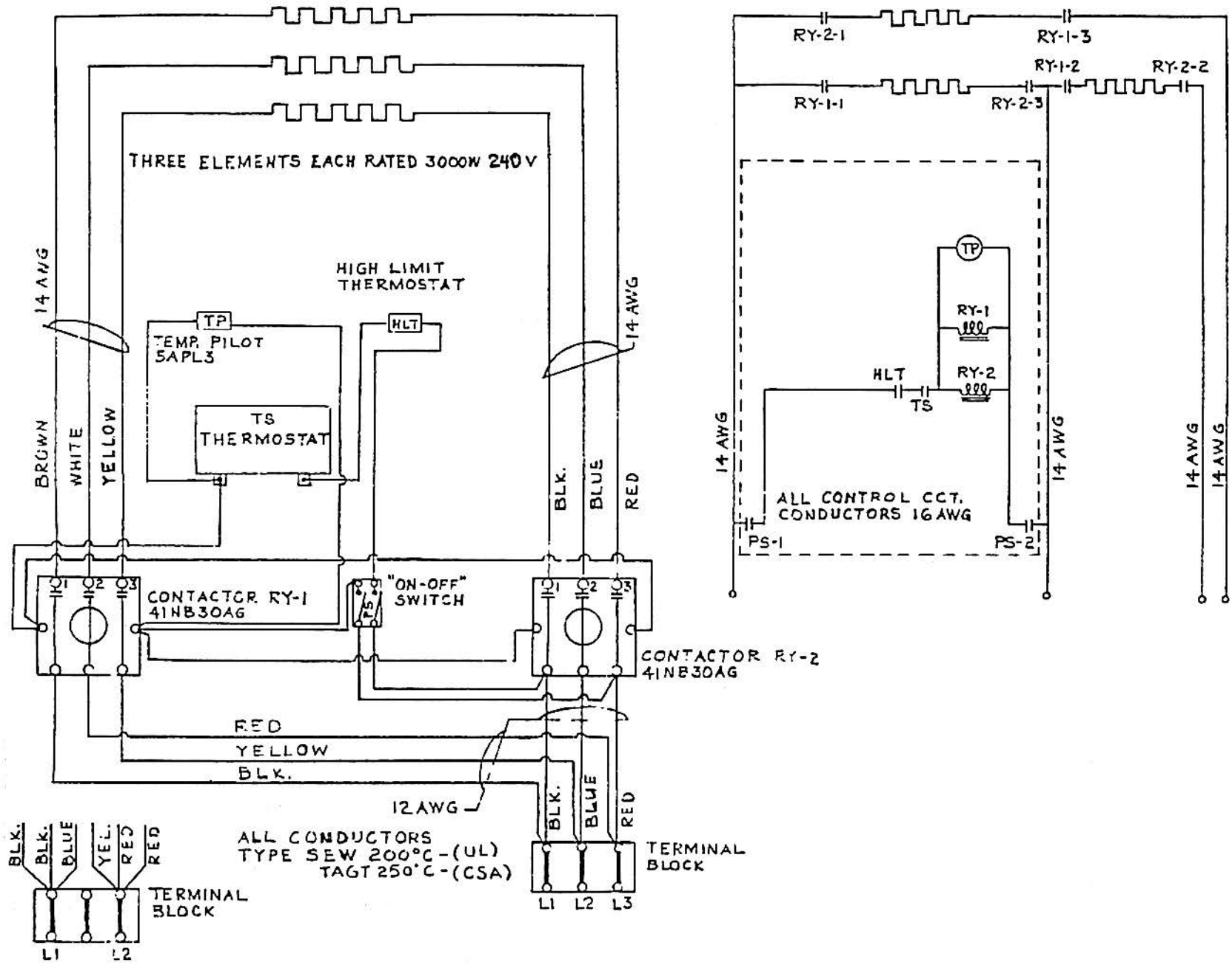

SINGLE PHASE CONNECTION

THREE PHASE CONNECTION

WIRING DIAGRAM 220V-380V - 9 KW

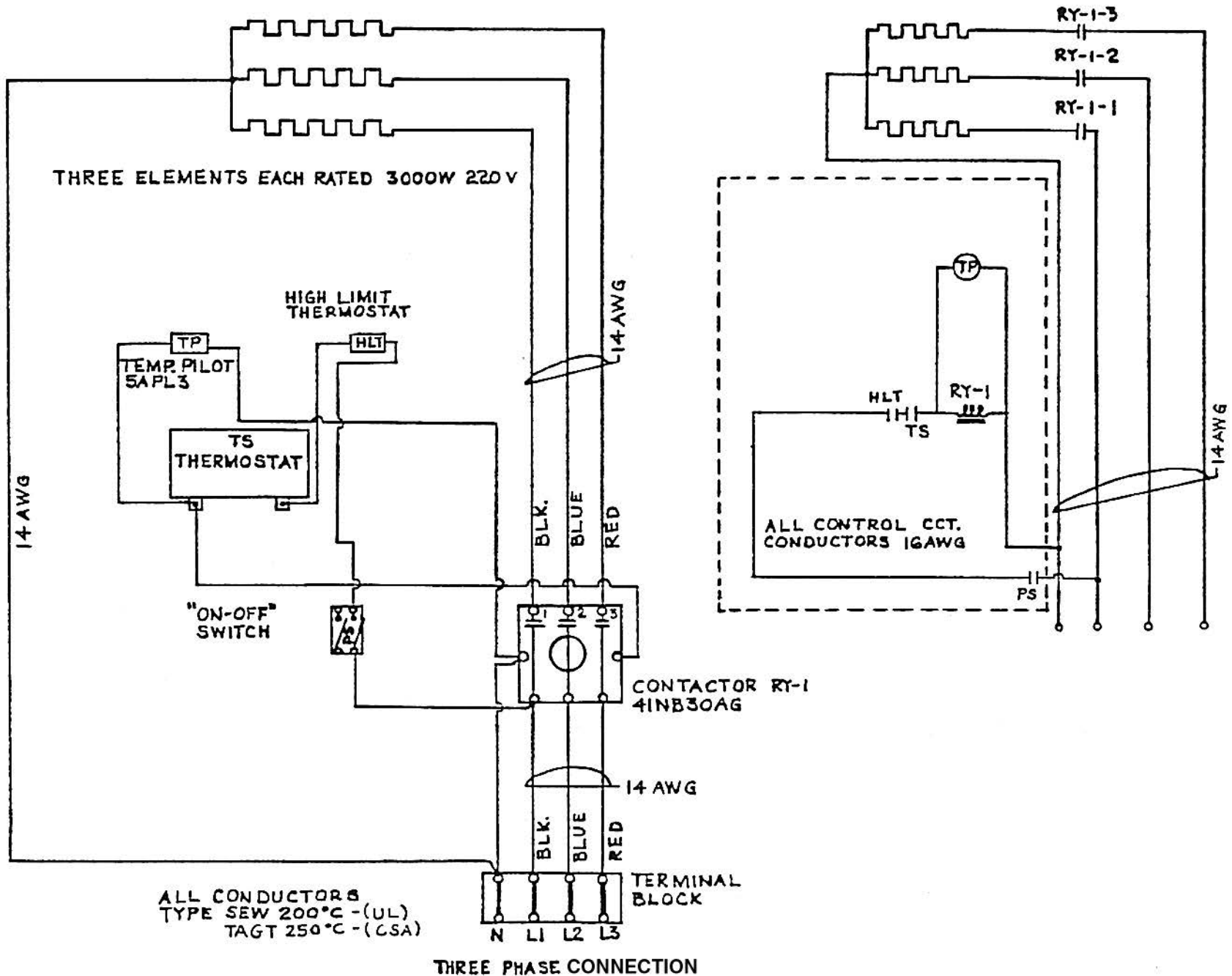

ALL CONDUCTORS  
TYPE SEW 200°C -(UL)  
TAGT 250°C -(CSA)

THREE ELEMENTS EACH RATED 3000W 220V

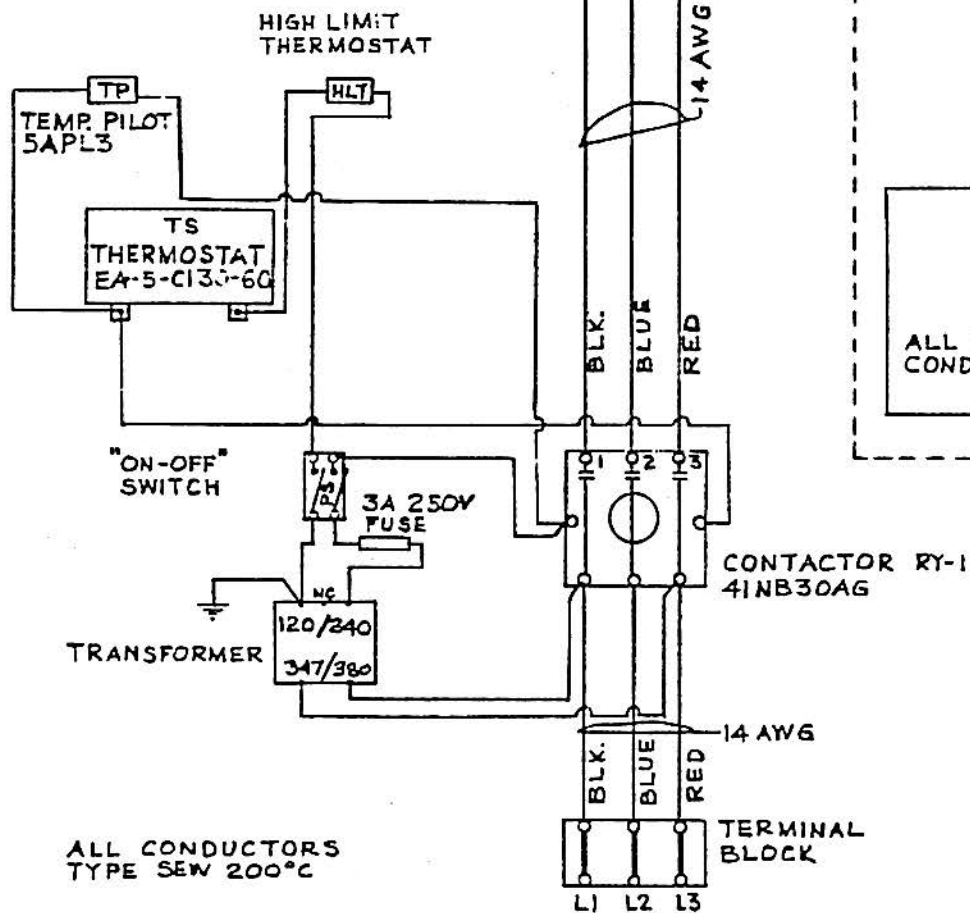

THREE PHASE CONNECTION

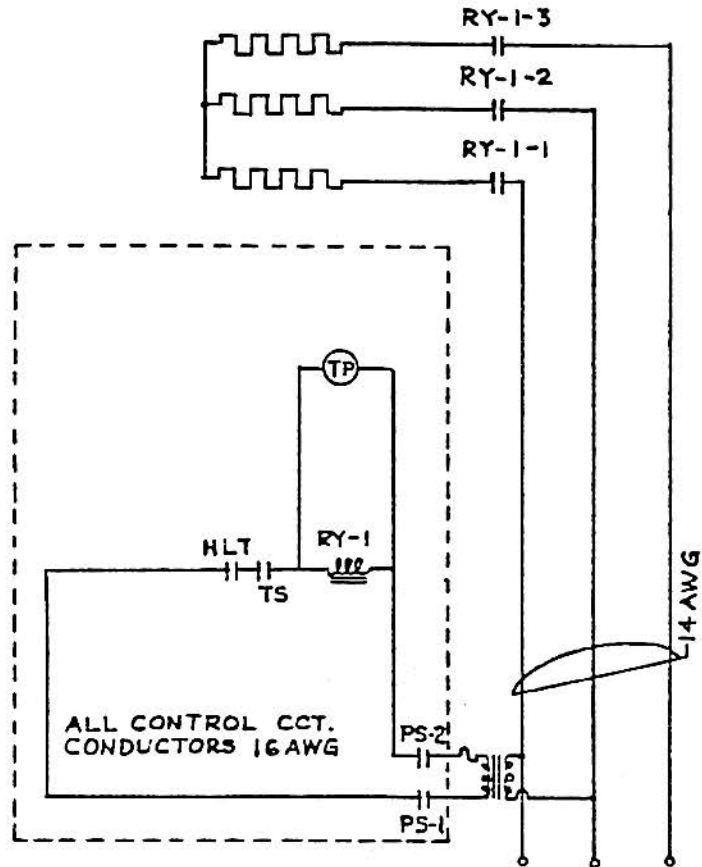



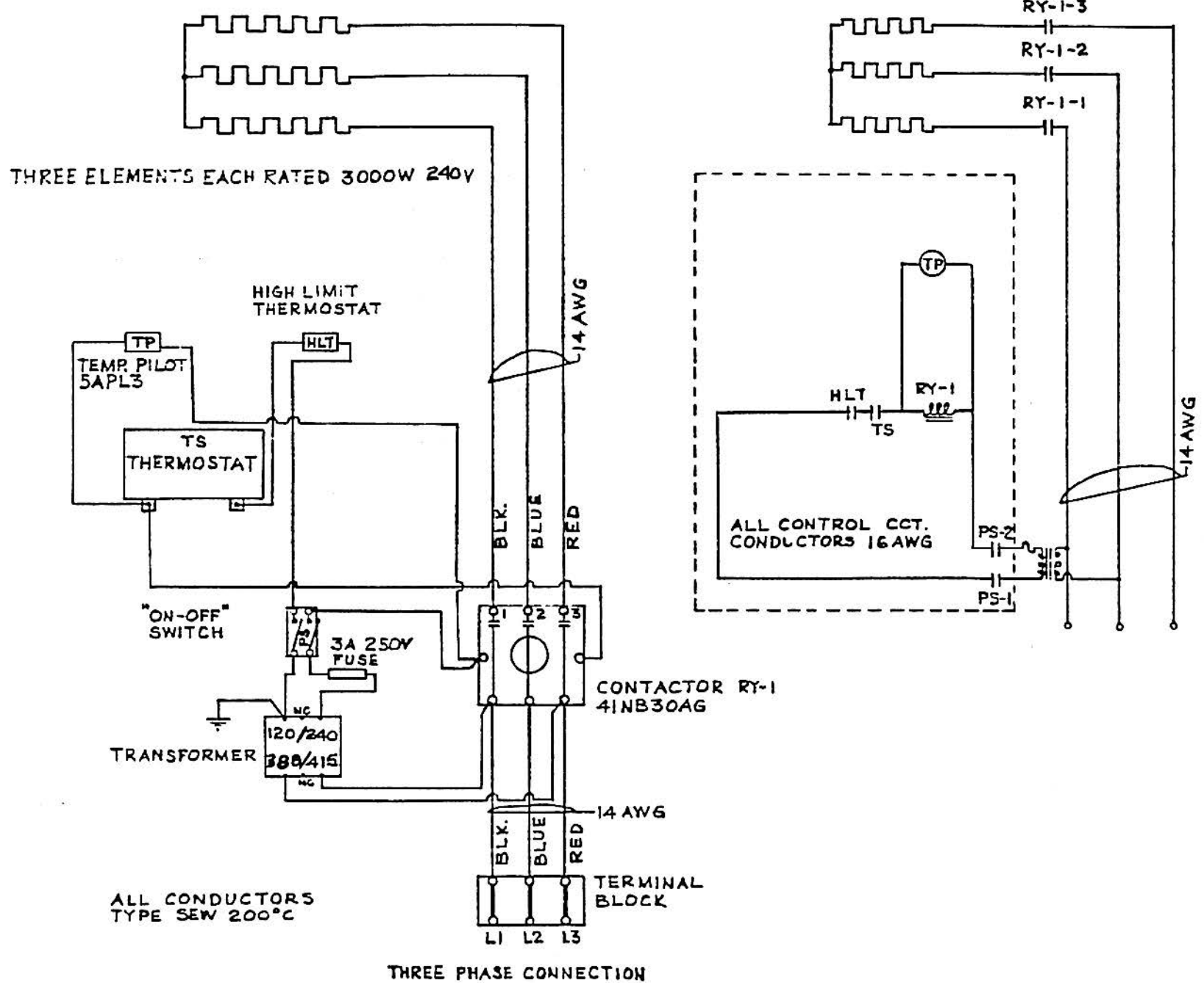

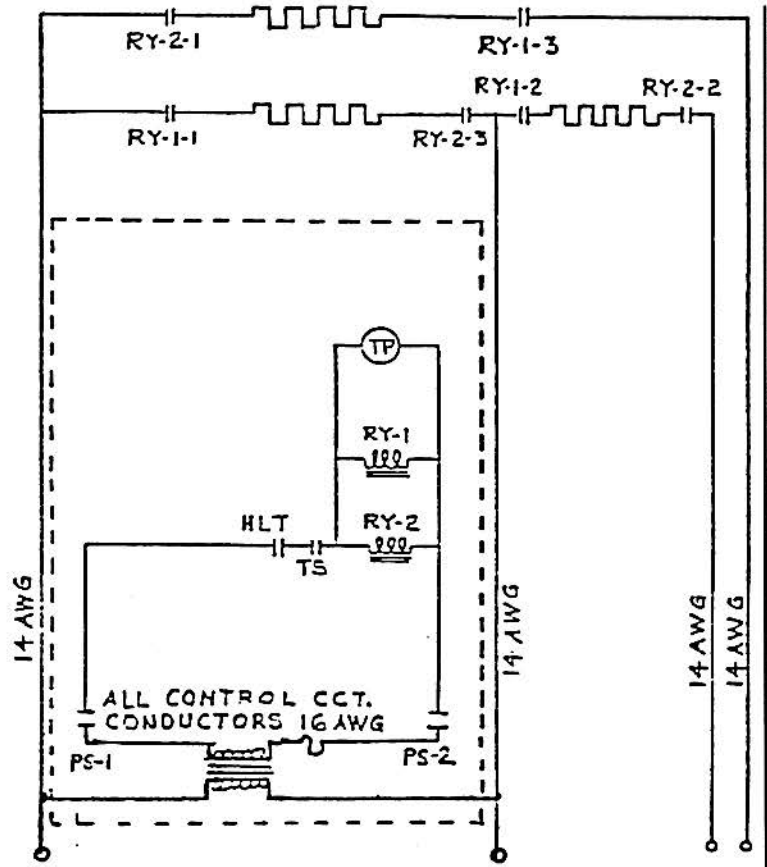
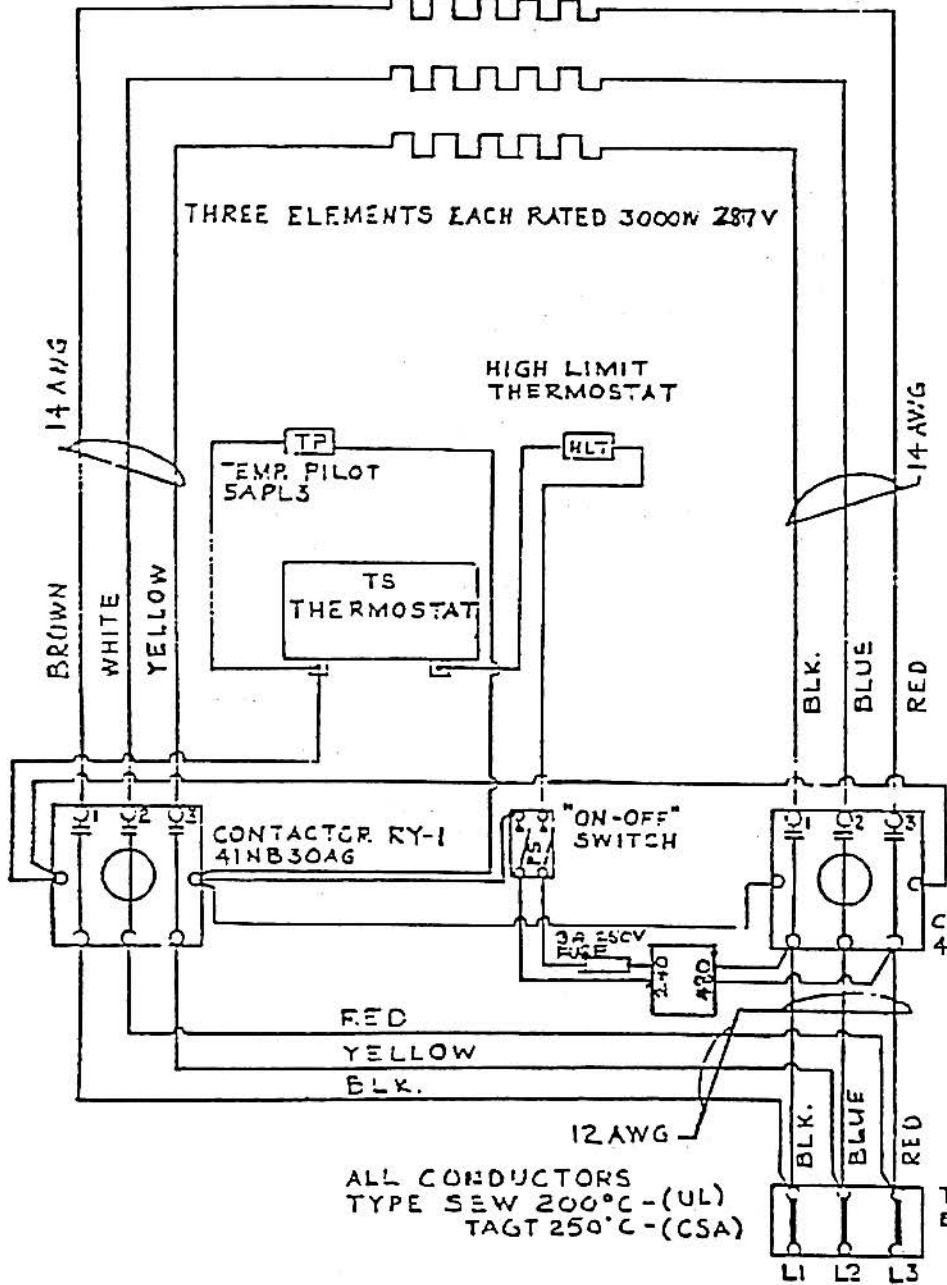

THREE PHASE CONNECTION