



## Sink-Mount Rinse-o-matic®

### Blender Container Rinser

The Vitamix Sink-Mount Rinse-o-Matic can be used with any 10-½" tall container.  
The Sink-Mount Rinse-o-Matic is designed to be paired with a Vitamix Advance Container.

### Use and Care Manual

Read and save these instructions

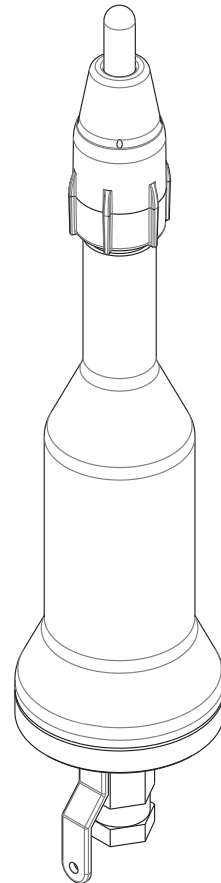



Vita-Mix® Corporation  
8615 Usher Road  
Cleveland, OH 44138-2103 U.S.A.  
800.886.5235  
**vitamix.com**

# CONTENTS

Contents .....	2
Important Safeguards .....	3
Installation .....	4
Operation .....	8
Caring for your Product.....	9
Appendix A .....	10
Warranty.....	13
Specifications .....	16
Parts List.....	16

# IMPORTANT SAFEGUARDS

**⚠️ WARNING:** To avoid the risk of serious injury when using your Rinse-o-Matic, basic safety precautions should be followed, including the following.

⚠️ WARNING		
	<p><b>To Avoid Injury.</b> Read and understand use and care manual before operating this product.</p>	

## Sink-Mount Rinse-o-Matic

⚠️ WARNING	
	<p><b>To Avoid Injury.</b> Use cold water only. Hot water will cause scalding under pressure. Water pressure is not to exceed 80 psi.</p>

## Container

1. Container blades are sharp. Be very cautious when cleaning and rinsing a blender container.
2. Keep hands and utensils out of the container to prevent the possibility of severe personal injury and/or damage.

# INSTALLATION

## ⚠ CAUTION



### To Avoid Property Damage.

- Damage to the Rinse-o-Matic as a result of improper installation is not covered under warranty.
- Vitamix is not responsible for property damage as a result of improper installation and/or improper use.

## IMPORTANT!

- Inspect underneath the sink for any interference with existing plumbing BEFORE installation.
- If the Rinse-o-Matic is being installed in a three-compartment sink that is used for wash, rinse, and sanitize, the Rinse-o-Matic MUST be installed in the rinse sink. **The installation MUST comply with all applicable federal, state and local plumbing and health codes having jurisdiction.**
- The Rinse-o-Matic is intended to rinse the container, not to sanitize. Cleaning and sanitizing MUST comply with all applicable federal, state and local health codes having jurisdiction.
- Connect to cold water supply only.
- When plumbing to the Rinse-o-Matic, use as few elbows and tees as possible.
- All water line fittings are 1/4" NPT.

## Required Tools/Materials:

- Hammer
- Center punch
- Cordless drill
- 1-3/4" hole saw or a 1-3/4" knock out
- Round file
- Pliers, channel locks or pipe wrench
- 3/4" open end wrench or adjustable wrench
- Petroleum Jelly
- Teflon® tape
- Mounting Hole Template (Refer to "Appendix A")

## Unpacking

1. Check for any obvious damage to the carton or its contents. If damage is found, contact Vitamix Technical Service at 800.886.5235.
2. Remove all loose packing and components from the carton.

# INSTALLATION

## Installation

1. Check underneath the sink for any interference with existing plumbing.
2. Cut out the Mounting Hole Template. Refer to Appendix A for important installation information.
3. Put the mounting hole template on the sink bowl surface. Locate the center of the mounting hole a minimum of 3 ½ inches from any side wall of the sink bowl. Locate the mounting hole on the flattest surface of the sink bowl as sink bowls tend to taper toward the drain.

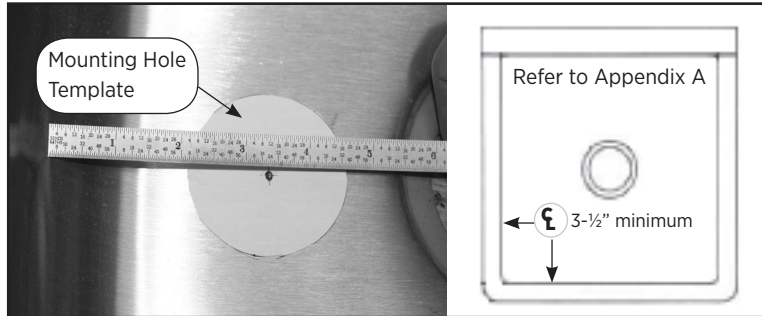

4. Use a center punch to make a dent in the bottom of the sink to mark the center of the mounting hole.

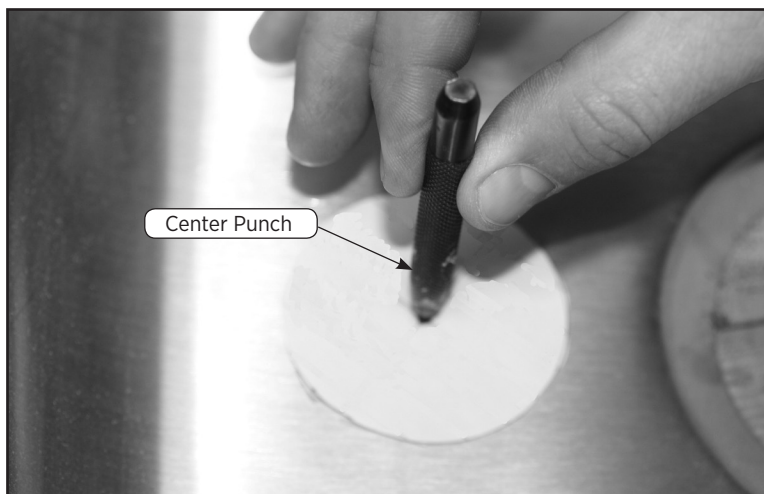

5. Cut out the mounting hole in the sink bowl using a 1-¾" hole saw and drill.

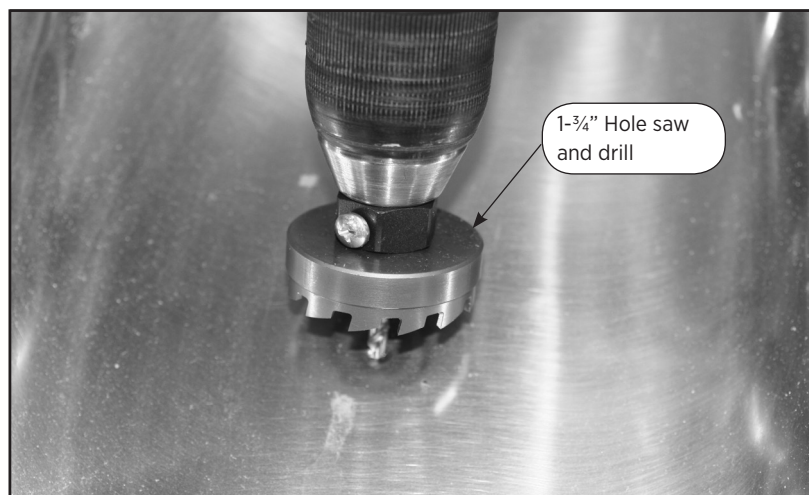

# INSTALLATION

## ⚠ CAUTION



### Sharp Edges.

Mounting hole edges will be sharp

6. Use a round file to remove sharp edges and burrs along edges of mounting hole cutout.

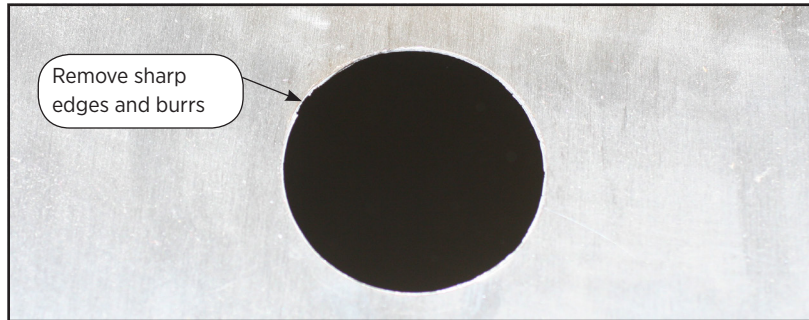

7. Apply a thin coating of Petroleum Jelly to the O-ring. Put the O-ring into the groove on the bottom of the Rinse-o-Matic base.

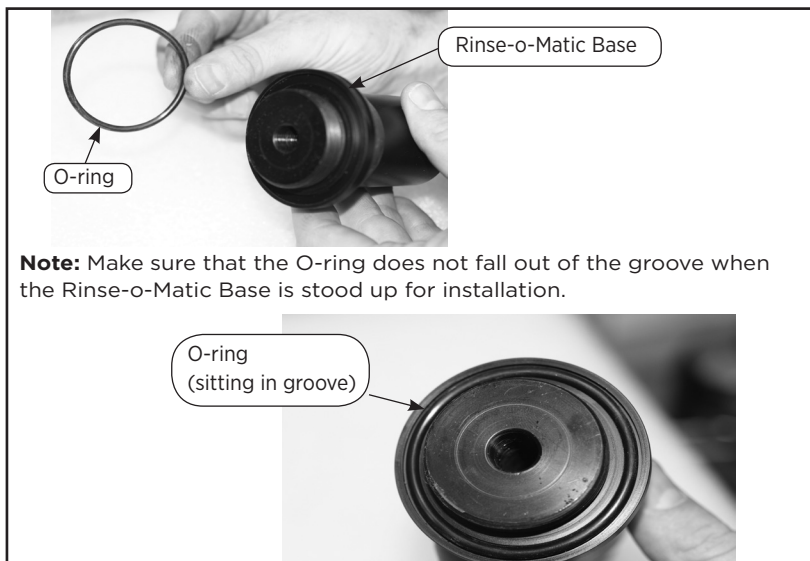

8. Insert the bottom of the Rinse-o-Matic Base into the mounting hole in the sink.

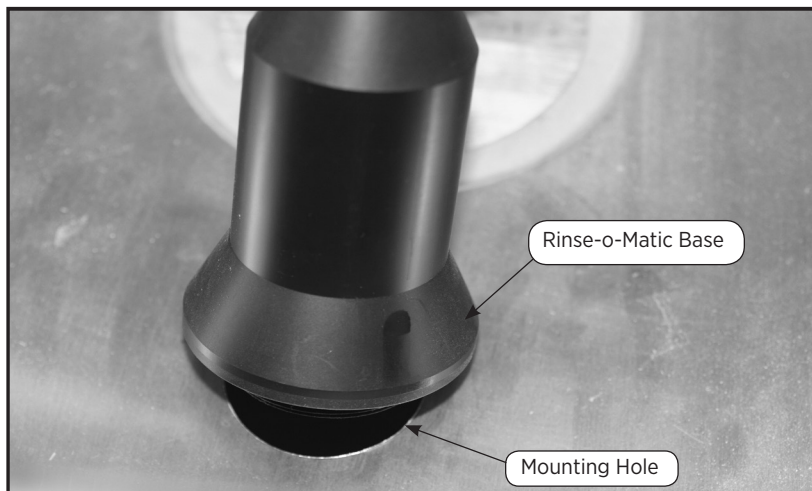

# INSTALLATION

9. Grip the Rinse-o-Matic base with one hand. Reach under the sink and thread the nut onto the threads on the underside of the Rinse-o-Matic base.
10. Using a pair of channel locks, carefully and securely tighten the nut.

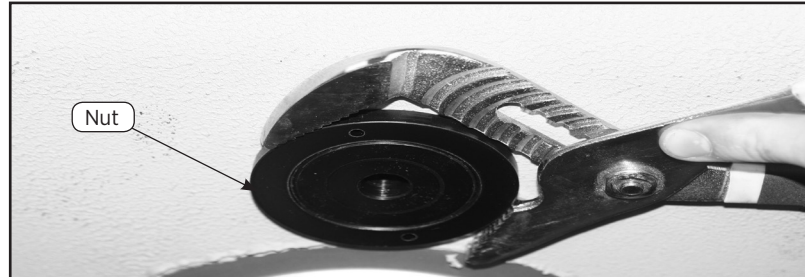

11. Plug drain and fill the sink with 2 to 3 inches of water. Check underneath the sink for leaks.
12. Follow these instructions if a leak is found:
  - a. Drain the sink.
  - b. Unscrew the nut from the base of the Rinse-o-Matic.
  - c. Pull the Rinse-o-Matic base out of the mounting hole.
  - d. Check to make sure the O-ring is in place in the groove.
  - e. Follow Installation steps 1-6. Proceed to step 8 if no leaks are found.
13. Apply Teflon® tape on the threads of the shut off valve. Thread the shutoff valve into the bottom of the Rinse-o-Matic base.
14. Securely tighten the shutoff valve using a ¾ inch open end or adjustable wrench. DO NOT use the handle on the shutoff valve to tighten.

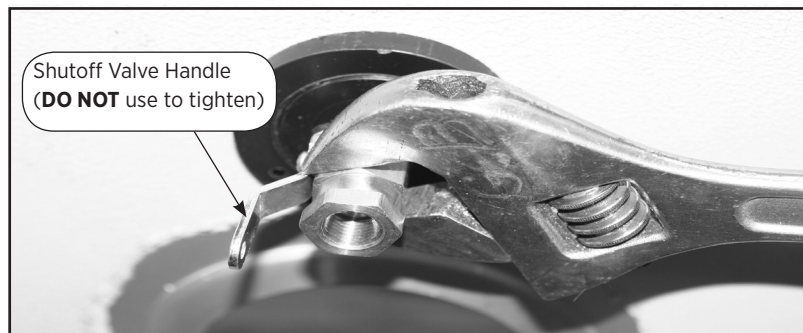

## ⚠ WARNING



### To Avoid Injury.

Use cold water only. Hot water will cause scalding under pressure.  
Water pressure is not to exceed 80 psi.

15. Plumb the Rinse-o-Matic to the cold water supply. The installation MUST comply with all applicable federal, state and local plumbing and health codes having jurisdiction.

# OPERATION

## Rinsing Instructions

### IMPORTANT!

For items with a blade assembly, make sure the blades are not resting on the tip of the valve assembly. The bottom internal surface of the item being rinsed should be in contact with the valve assembly.

1. Place the item to be rinsed upside down over the top of the Sink-Mount Rinse-o-Matic until it rests on the valve assembly.
2. Press down on the item to be rinsed. This will depress the valve assembly and release the water. Hold for 2-5 seconds or until the item is fully rinsed.
3. Lift the item from the Sink-Mount Rinse-o-Matic. The water will stop flowing.
4. Continue with the cleaning and sanitizing process necessary for the item. Cleaning and sanitizing **MUST** comply with all applicable federal, state and local health codes having jurisdiction.

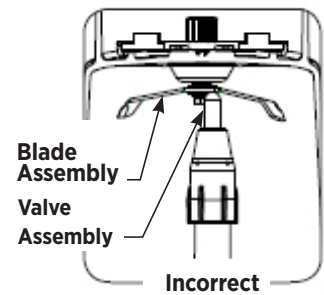
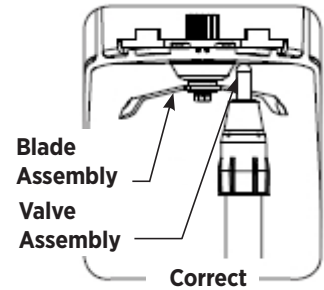



# CARING FOR YOUR PRODUCT

## Cleaning the Sink-Mount Rinse-o-Matic

Wash all surfaces with a soft cloth. Use a soft brush when necessary to remove residue.

## Sprayhead and Valve Assembly Replacement

The sprayhead and valve assembly may wear due to improper contact with the blade while rinsing containers. Damaged parts may affect rinsing performance. Inspect the sprayhead and valve assembly weekly and replace parts when necessary.

⚠ CAUTION		
	<p><b>To Avoid Injury.</b> Read and follow instructions when performing this operation.</p>	

**Note:** It is not necessary to remove the Sink-Mount Rinse-o-matic from the sink to perform this procedure.

1. Turn off the water supply.
2. To relieve water pressure, use a container to push down on the valve assembly, as if you were cleaning the container.
3. Rotate the sprayhead counterclockwise to loosen and remove it from the base. Discard the worn sprayhead.
4. Remove the valve assembly and discard it.
5. Put the replacement valve assembly into the Rinse-O-Matic base.
6. Put the replacement sprayhead onto the Rinse-O-Matic base.
7. Rotate the sprayhead clockwise by hand to tighten until snug. **Do not use any tools to tighten the sprayhead onto the base.**

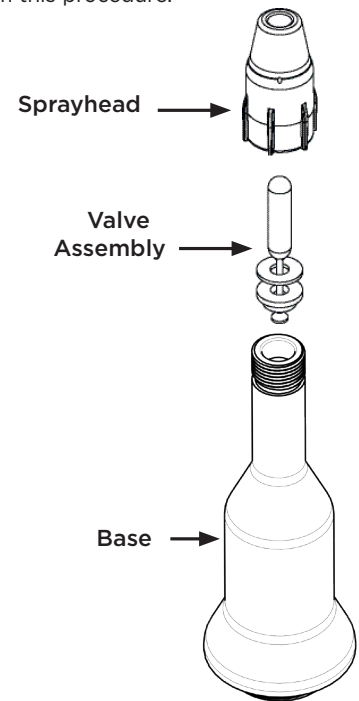

## Troubleshooting

Problem:	Possible Actions:
Water leaks between the spray head and the rinser or from holes on spray head	<ol style="list-style-type: none"> <li>1. Make sure the sprayhead has been screwed on and is tight.</li> <li>2. Turn the water supply to the Rinse-o-Matic off. Depress the sprayhead plunger and unscrew the sprayhead. Check the sprayhead for damage and debris. Clean sprayhead if necessary and screw sprayhead onto threads.</li> </ol>
Water leaks underneath sink at mounting hole location.	Refer to Installation; STEP 12 on page 7.

If the problem is not solved using these suggestions, technical help is available by calling the Vitamix Technical Support at 800.886.5235. If you purchased your equipment outside of the U.S.A., contact your local Vitamix Distributor or call the Vitamix International Division at +1.440.782.2450. For online help, visit [www.vitamix.com/foodservice](http://www.vitamix.com/foodservice).

APPENDIX A - IMPORTANT PLACEMENT INFORMATION AND MOUNTING HOLE TEMPLATE

Drawing is FOR REFERENCE ONLY and is NOT TO SCALE. Mounting Hole template is to scale.

**\*Mounting Hole** - Only one mounting hole is required for installation. This drawing shows a mounting hole located in each of the 4 quadrants of the sink bowl for location information only.

NTS = Not to Scale

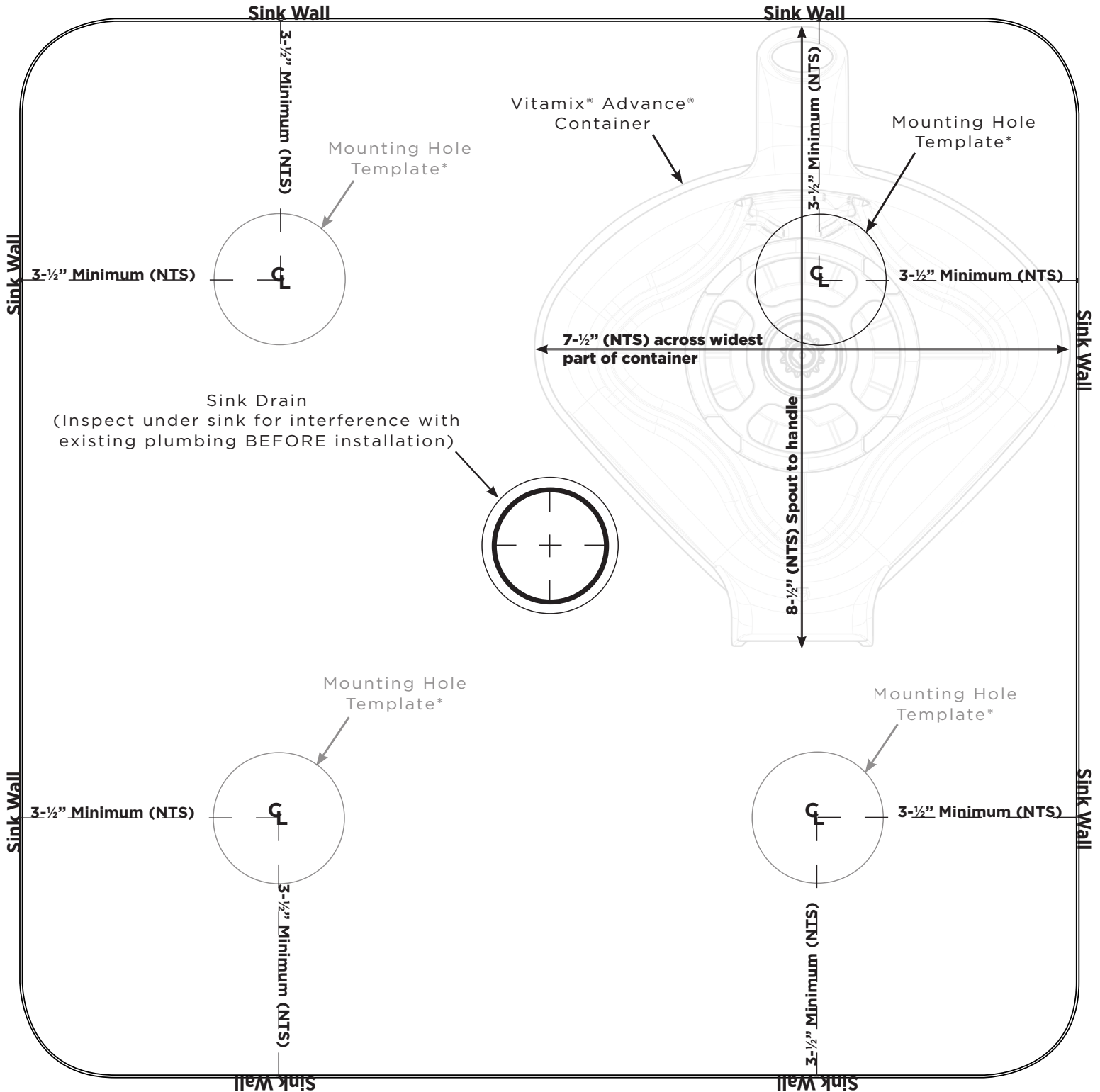

## ⚠ CAUTION



### To Avoid Property Damage.

- Inspect underneath sink for interference with existing plumbing BEFORE installation.
- Make sure the mounting hole is offset a MINIMUM 3-1/2" from ANY sink wall.
- Damage to the Rinse-o-Matic as a result of improper installation is not covered under warranty.
- Vitamix is not responsible for property damage as a result of improper installation and/or improper use.
- Installation must comply with all applicable federal, state and local plumbing and health codes having jurisdiction.

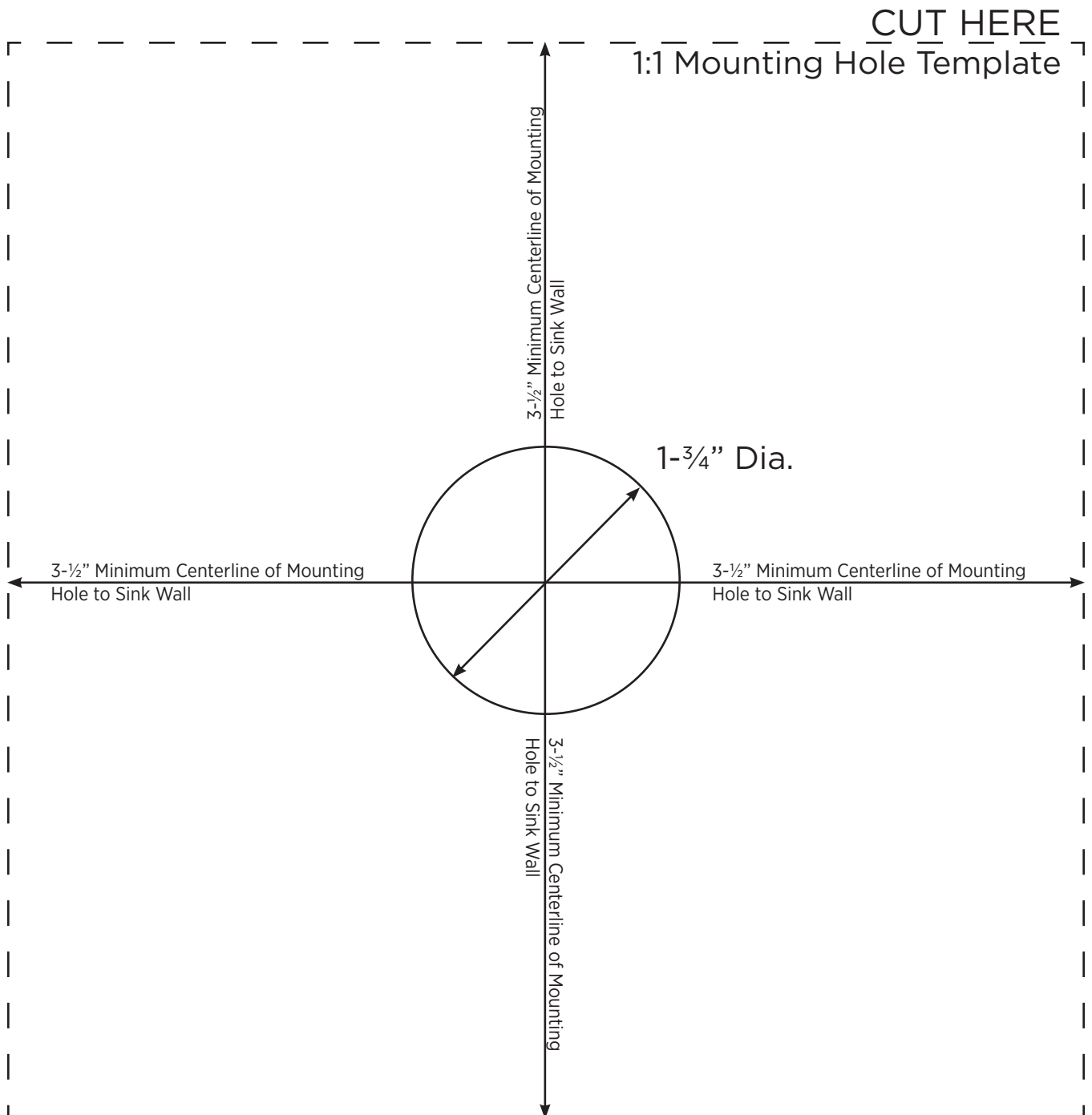

**This page intentionally left blank**

# WARRANTY

## LIMITED WARRANTY- (Unless otherwise covered by Contract)

Vita-Mix® Corporation (hereinafter “Vitamix”) warrants to the original end-user (“Purchaser”) that its commercial Rinse-o-Matic, the “Equipment”) will be free from defects in material and workmanship for one (1) year from the date of purchase as described herein and subject to the conditions set forth below. Proof of purchase is required.

The following are the sole remedies of the Purchaser and set forth the only warranty obligations of Vitamix.

No employee of Vitamix or any other person is authorized to make any warranty in addition to or amendment of the following warranties.

### WHAT IS COVERED UNDER WARRANTY

Vitamix warrants to the original end-user that:

If the Equipment fails due to defects in material or workmanship within one (1) year from the date of purchase, then Vitamix will assume the cost of all parts or will replace the unit.

The sole obligation of Vitamix under these warranties is to repair or replace the warranted part or parts as determined exclusively by Vitamix.

**IN NO EVENT, WHETHER BASED ON CONTRACT, INDEMNITY, WARRANTY, TORT (INCLUDING NEGLIGENCE), STRICT LIABILITY OR OTHERWISE, SHALL VITAMIX BE LIABLE FOR ANY SPECIAL, INDIRECT, INCIDENTAL OR CONSEQUENTIAL DAMAGES WHATSOEVER INCLUDING, WITHOUT LIMITATION, LOSS OF PROFIT OR REVENUE. THE ABOVE LIMITED WARRANTY IS YOUR EXCLUSIVE REMEDY, AND YOU AND VITAMIX HEREBY EXPRESSLY DISCLAIM ALL OTHER WARRANTIES OR CONDITIONS, EXPRESS OR IMPLIED, STATUTORY OR OTHERWISE, INCLUDING ANY IMPLIED WARRANTY OF MERCHANTABILITY AND ANY IMPLIED WARRANTY OF FITNESS FOR A PARTICULAR PURPOSE, AND, WITHOUT LIMITING THE GENERALITY OF THE FOREGOING, YOU AND VITAMIX HEREBY EXPRESSLY EXCLUDE, TO THE EXTENT PERMITTED BY LAW, THE APPLICATION OF ANY SALE OF GOODS LEGISLATION AND THE UNITED NATIONS CONVENTION ON CONTRACTS FOR THE INTERNATIONAL SALE OF GOODS, AS MAY BE APPLICABLE.**

Some jurisdictions do not allow a limitation on implied warranties or on special, incidental or consequential damages.

### WHAT IS NOT COVERED UNDER WARRANTY (Coverage Exclusions)

These warranties do not include repairs needed due to:

- A. Normal wear-and-tear;
- B. Abuse, misuse, negligent use;
- C. Alteration of the Equipment;
- D. Exposure to extreme conditions; or
- E. Improper installation of the Equipment, including but not limited to poor workmanship, not following specifications provided

### WHEN DO THE WARRANTIES APPLY (Coverage Conditions)

The warranties contained herein run only to the original end-user and are not transferable. To make a warranty claim, proof of purchase is required.

Any warranty offered by Vitamix is only valid if used in accordance with: a) the owner’s manual that may also be accessed at [vitamix.com](http://vitamix.com) b) the express warranty; and c) any and all maintenance instructions regardless of when they are supplied.

### WHAT CAUSES THE WARRANTY TO BE VOID

All warranties are void if:

- Any component of a covered piece of Equipment has been modified, altered, “reconditioned” or repaired by persons someone other than Vitamix, an authorized Vitamix Service Center or an authorized Vitamix Distributor.
- Any covered Vitamix Equipment is used with a component not expressly authorized in writing by Vitamix; or
- Any Equipment is improperly installed, including but not limited to poor workmanship, not following specifications provided.

# WARRANTY

## HOW TO OBTAIN WARRANTY COVERAGE AND REPAIR

Who to Contact For Warranty Service and Repair. In the event your Vitamix Equipment needs service or repair covered by the terms of this warranty, please call Vita-Mix Corporation or a local distributor for warranty assistance.

- For Equipment purchased and located in the U.S.A., call Vitamix Technical Support: 800.886.5235
- For Equipment purchased outside the continental U.S.A., contact your authorized Vitamix Distributor, or contact the Vitamix International Division at +1.440.782.2450 or email [international@vitamix.com](mailto:international@vitamix.com) for a distributor near you.

You will be asked to provide proof of purchase for the Equipment. If the remote technical support team cannot fix the Equipment remotely, the Equipment will need to be serviced.

## How to Ship the Equipment for Service

- Obtain a Return Authorization Number Before Shipment.** Do not return or send in Equipment without the approval from Vitamix. Under no circumstances will Vitamix be responsible for the cost of any unauthorized repairs. All Equipment returns must have the Return Authorization Number ("RA") clearly marked on the outside of the box. Any Equipment that is sent to Vitamix without prior authorization or approval will be returned to the shipper's address "as is" without repair.
- Shipping Equipment or Parts.**
  - In the United States. If the Equipment is under the above warranty Vitamix will ship replacement parts or a replacement Rinse o- Matic to the location where the Equipment was used at Vitamix's expense using standard ground freight. Purchaser will pay the shipping costs to return a Rinse o- Matic to Vitamix. If the Purchaser fails to return a malfunctioning Rinse o- Matic to Vitamix within thirty (30) days of the replacement Rinse o- Matic delivery, Vitamix or its Authorized Distributor may invoice the Purchaser the then-current price for the Rinse o- Matic. Purchaser will have the option to request expedited freight using the Purchaser's credit card to pay for all applicable shipping expenses. Vitamix will credit the Purchaser's account for the amount of the standard ground freight shipping expense.
  - In All Other Countries. If the Equipment is under the above warranty Vitamix or its Authorized Distributor will ship replacement parts or a replacement Rinse o- Matic to the location where the Equipment was used at the Purchaser's expense using standard ground freight unless otherwise specified. Purchaser will pay the shipping costs to return a malfunctioning Rinse o- Matic base to the Authorized Distributor. If Purchaser fails to return a malfunctioning Rinse o- Matic to Vitamix or its Authorized Distributor within thirty (30) days of the replacement Rinse o- Matic delivery, Vitamix or its Authorized Distributor may invoice the Purchaser the then-current price for the Rinse o- Matic.
- Properly Package The Returned Item.** Any item sent to Vitamix must be sent in original or sufficient packaging.



# SPECIFICATIONS

## Dimensions and Weight

Weight: 16.0 oz. (0.454 kg)  
Dimensions: Length: 11.25 in (28,58 cm)  
Diameter at base: 2.5 in. (6,4 cm)

## Plumbing

Cold Water Supply Pressure: 25 psi minimum / 80 psi maximum

# PARTS LIST

To order replacement parts, contact Vitamix Technical Support at 800.886.5235.

Drawing Reference	Part Number	Description
1	1443	Rinse-o-Matic Spray Head Kit
2	1462	Rinse-o-Matic Spray Head
		ROM Base/Body
		ROM Base/Body Nut 1.75x12 UN
		O-Ring/AS3578-226 x 1/8 Buna
		Shutoff Valve/Brass Ball/1/4 in NPT/ Female to Male

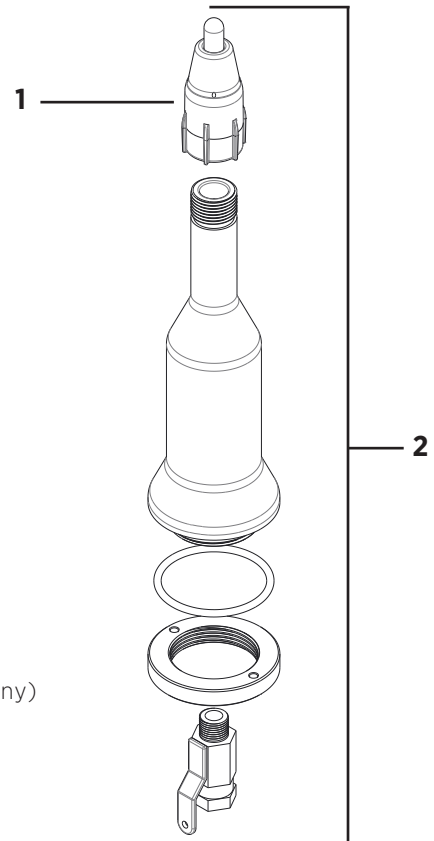

Telfon is a registered trademark of DuPont (E. I. du Pont de Nemours and Company)

When applicable:



To see the complete line of Vitamix® products,  
visit [vitamix.com](http://vitamix.com)



**Vita-Mix® Corporation**  
**Commercial Division**

8615 Usher Road, Cleveland, Ohio 44138 U.S.A.  
Tel: 440.235.0214 Email: [commercial@vitamix.com](mailto:commercial@vitamix.com)

©2013 Vita-Mix Corporation. No part of this publication may be reproduced or transmitted in any form or by any means or stored in a database or retrieval system without the written permission of the Vita-Mix Corporation.

Printed in the U.S.A.

103737 04/13