

Operator's Manual

COUNTERTOP CONVECTION OVEN



Item	Model	Description	Shelves (Included)	Watts	Amps	Voltage	Plug
40703	COA7002	Half-size	3	1,500	12.5	120	5-15P
40701	COA8004	Half-size	4	2,520	11	230	6-15P
40702	COA8005	Full-size	4	5,600	25.5	230	6-50P

Thank you for purchasing this Vollrath Counter Top Cooking Equipment. Before operating the equipment, read and familiarize yourself with the following operating and safety instructions. **SAVE THESE INSTRUCTIONS FOR FUTURE REFERENCE.** Save the original box and packaging. Use this packaging to ship the equipment if repairs are needed.

SAFETY PRECAUTIONS

To ensure safe operation, read the following statements and understand their meaning. Please read carefully.

WARNING

Warning is used to indicate the presence of a hazard that *can* cause severe personal injury, death, or substantial property damage if the warning is ignored.

CAUTION

Caution is used to indicate the presence of a hazard that *will* or *can* cause *minor* personal injury or property damage if the caution is ignored.

NOTE

Note is used to notify people of installation, operation, or maintenance information that is important but not hazard-related.

	 WARNING
	Fire Hazard. Have this equipment installed by a qualified installer in accordance with all Federal, State and Local Codes. Failure to install this equipment properly can result in injury or death.

	 WARNING
	Fire Hazard. This unit is designed to be used with legs. Do not use without legs installed. Use of this equipment without legs can cause the unit to over heat and cause a fire.

 	 WARNING
	Fire Hazard and Burn Hazard. Injuries or death can occur if this equipment is not used properly. To reduce risk of injury or death: <ul style="list-style-type: none"> • Unit should only be used in a flat, level position. • Let hot unit cool before cleaning or moving. • Do not spray controls or outside of unit with liquids or cleaning agents. • Do not operate unattended.

For Your Safety!

These precautions should be followed at all times. Failure to follow these precautions could result in injury to yourself and others.

To reduce risk of injury or damage to the equipment:

- Do not set items on door, use the door as a shelf or lean on door.
- Use only grounded electrical outlets matching the nameplate rated voltage.
- Do not use an extension cord with this equipment. Do not plug this equipment into a power strip or multi-outlet power cord.
- Unplug equipment, turn off and let it cool before cleaning or moving.
- Keep equipment and power cord away from open flames, electric burners or excessive heat.
- Do not operate equipment in public areas and/or around children.
- The equipment may be hot, even though the pilot light(s) is not on.
- Do not operate if equipment has been damaged or is malfunctioning in any way.
- Do not clean the equipment with steel wool.

FUNCTION AND PURPOSE

This unit is intended to be used for cooking fresh or frozen foods in a commercial foodservice operations only. It is not intended for household, industrial or laboratory use.

Before using this equipment it must be cleaned and dried thoroughly. Clean all surfaces before use. Failure to clean surfaces before using the unit could cause food contamination.

This equipment is a medium duty appliance capable of a wide variety of bake applications. The temperature is thermostatically controlled. The temperature range is 150°F - 570°F (65°C - 299°C).

UNPACKING THE EQUIPMENT AND INITIAL SETUP

When no longer needed, dispose of all packaging and materials in an environmentally responsible manner.

1. Remove all packing material and tape, as well as any protective plastic from the equipment.
2. Clean any glue residue left over from the plastic or tape.

NOTE:

There must be a minimum of 12" (30.4 cm) between the equipment and any surrounding walls. The surrounding walls must be made of noncombustible materials. The equipment must be installed in accordance with local fire and building regulations.

3. Place the equipment in the desired position and height.
4. **Model 40702 Only.** This model is equipped with a water spray feature. To utilize the water spray feature the unit should be connected to a potable water supply with a pressure between 3 and 30 PSI. The 4" legs must be installed to comply with NSF.
5. Plug the equipment into a properly grounded electrical supply matching the nameplate rating. Damage to the equipment can occur if incorrect power is supplied to equipment.

CONTROLS

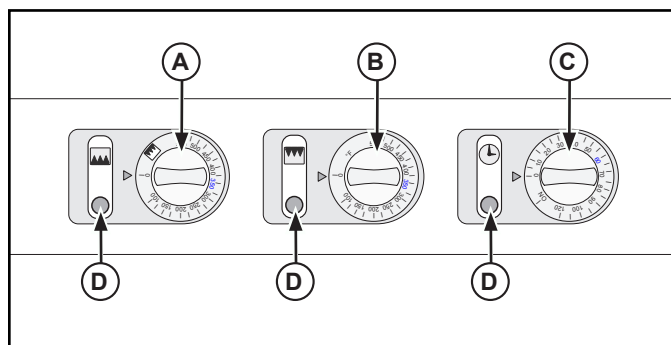

Figure 1. 40703 and 40701 Controls.

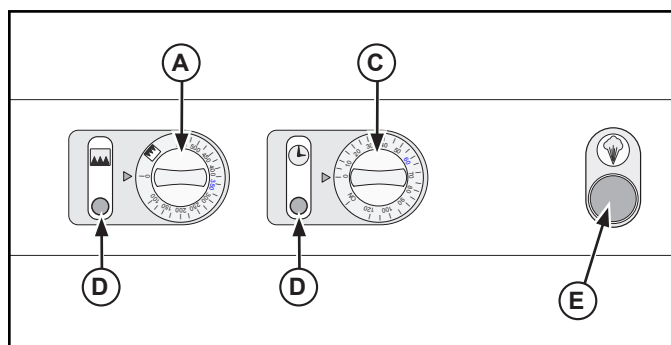









Figure 2. 40702 Controls.

- (A) BAKE CONTROL** . Used to set or adjust the temperature of the oven. The numbers on the dial correspond with the oven temperature. The "0" position is off. The timer needs to be "ON" for the heating elements to function.
- (B) BROWN CONTROL**  (40701 and 40702 Only). Used to set or adjust the temperature of the upper element. The numbers on the dial correspond with the oven temperature. The bake control must be set in the "BROWN" position and the timer in the "ON" position for the upper element to heat. The fan does not operate when the brown function is operating.
- (C) TIMER** . Timer can be set for 1 - 120 minutes, or it can set to constant "ON" position. The timer must be operating in order for "Bake" to function. The timer has no bell or buzzer.
- (D) PILOT LIGHTS**. This light indicates that the oven is heating and the timer is activated. Once the set temperature has been reached the light will go out. Equipment will continue to maintain heat and temperature as the light cycles on and off. This light is not a power "ON" indicator. The timer pilot light will illuminate when the timer is operating.
- (E) MIST CONTROL BUTTON**  (40702 Only). A push button located on the front panel of the oven. Sprays a small amount of water to enter the baking chamber.



OPERATION

	 WARNING
	Burn Hazard. Do not touch hot food, liquid or heating surfaces while equipment is heating or operating.
Hot surfaces and food can burn skin. Allow the hot surfaces to cool before handling. Do not drop or spill water onto the cooking surface as it can spray or splatter.	

Before initial use burn-in procedure:

1. Plug the equipment into a properly grounded electrical supply matching the nameplate rating. Damage to the equipment can occur if incorrect power is supplied to equipment.
2. Close the door and turn the bake control  (A) to 525°F (274°C), set the timer  (C) for 30 minutes. During this burn-in you may notice a slight odor, this is normal. See Figures 1 and 2.

All Models: Baking Function - Used to bake or cook food product.

1. Place the wire shelves or pans in the desired positions inside the unit. Allow a space of at least 2" (5 cm) between wire shelves or pans.
2. Set the bake control  (A) the desired temperature.
3. Set the timer control  (C) to the desired time. The fan and oven light will operate continuously. The heating elements will cycle on and off to maintain a consistent temperature.
4. Place food product into the unit and monitor.

Models 40701 and 40703 Only: Browning Function - Used to brown a food product has been fully cooked.

1. Place the shelves in the desired positions inside the unit. Assure the food product is not too close or touching the inside top or heating element.

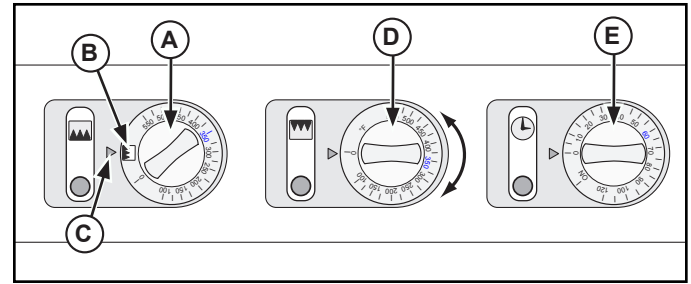





Figure 3. 40703 and 40701 Controls set for the Browning Function.

NOTE:

The fans do not operate in the browning mode. It is recommended that the door be opened slightly during browning.

2. Switch the bake control  knob (A) to the brown function icon  (B) to the indicator (C). See Figure 3.
3. Set the brown control  knob (D) to the desired temperature. The timer control (E) does not need to be used for the browning function to operate.
4. Place food product into the unit and monitor.



Models 40702 Only: Humidity Function - Used to provide a heavier crust on bread and rolls.

The humidity function works best if activated at the beginning of the baking cycle after the oven has reached the cooking temperature and the food product has just been placed into the oven.

1. Press the mist control  button (E) to activate a spray of water into the cooking chamber. See Figure 2. Do not press the button longer than 2-second pulses.

CLEANING

To maintain the appearance and increase the service life, clean your equipment daily.

	 WARNING
	Electrical Shock Hazard. Keep water and other liquids from entering the inside of the equipment. Liquid inside the equipment could cause an electrical shock.
Do not spray water or cleaning products. Liquid could contact the electrical components and cause a short circuit or an electrical shock. Do not use equipment if power cord is damaged or has been modified	

1. Turn off and unplug the equipment.
2. Allow the equipment to cool completely before cleaning.

NOTE:

Do not immerse the cord, plug or equipment in water or any other liquid.

3. Using a damp cloth, sponge dipped in soapy water to clean the outside of the equipment.
4. Do not use caustic or abrasive cleaners on this unit.

The oven door may be removed for cleaning.

To remove and install the oven door:

1. Allow the equipment to cool completely before removing the door.
2. Open the door (B). See Figure 4.
3. Note the down or back position of hinge locks (E). Check that both sides are in this position.

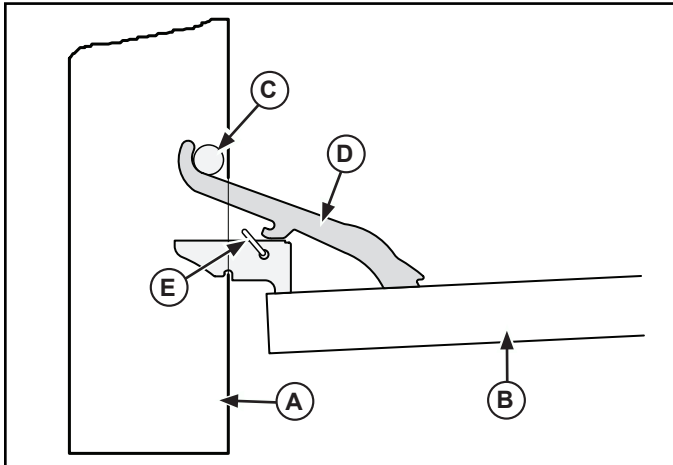

Figure 4. Oven Door and Hinge Lock (down or back position).

4. Place the hinge lock (E) over the hinge arm (D) as shown. Repeat on both sides. See Figure 5.

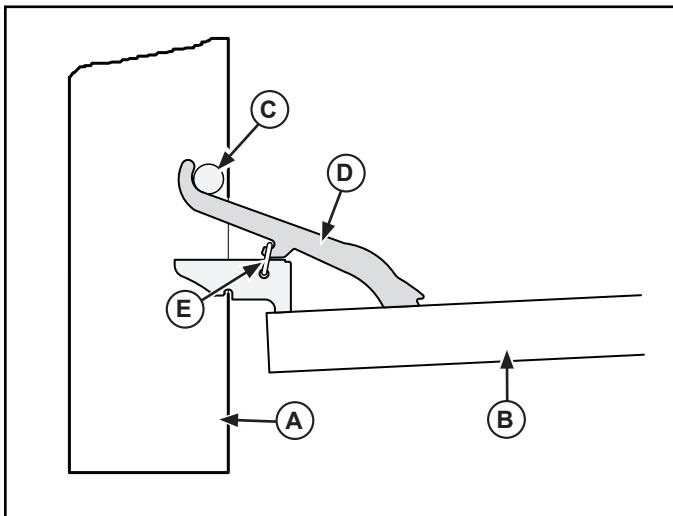

Figure 5. Oven Door and Hinge Lock (up or locked position).

5. Tilt the oven door (B) up slightly and lift the oven door out.
6. Door (B) may be cleaned.
7. Using a damp cloth, sponge dipped in soapy water to clean the door (B).
8. Use towels to completely dry the door (B) or allow it to air dry completely.

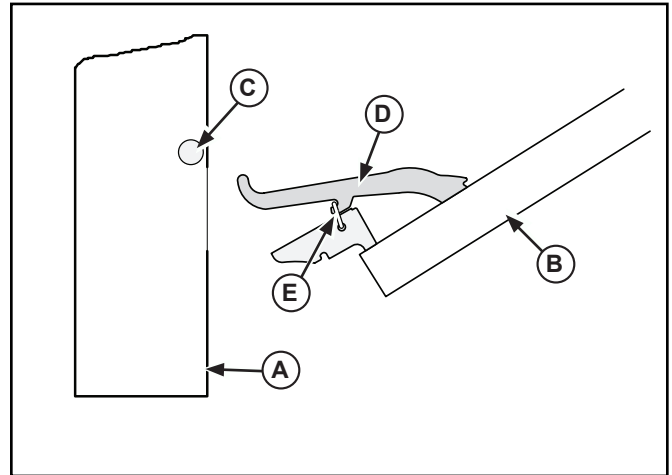

Figure 6. Oven Door removal and Installation.

9. Carefully set the oven door (B) into the oven (A). Place the arm (D) so that it sets under pin (C). See Figure 6.
10. Rotate the hinge lock (E) off the hinge arm (D) as shown. Repeat on both sides. See Figure 4.
11. Carefully open and close the door to verify that it is operating correctly. If not repeat steps 4 and 5.

MAINTENANCE

Replacement of the oven light.

1. Turn off and unplug the equipment.
2. Allow the equipment to cool completely before cleaning.
3. Unscrew the light cover.
4. Remove and discard the old light.
5. Install a new light. The new light must be rated for the high temperature and must match the nameplate voltage.
 - 40703, Mini Prima Pro, 120 Volt - 15 watts
 - 40701, Prima Pro, 220 Volt - 25 watts
 - 40702, Proton, 220 Volt - 25 watts
6. Install the light cover.

TROUBLESHOOTING

Problem	It might be caused by	Course of Action
Pilot Light does not come on when the temperature control is turned up.	The equipment is not plugged in.	Plug equipment in.
	Pilot Light malfunction.	Replace Pilot Light.
	Thermostat Control malfunction.	Replace Thermostat Control.
The light comes on, equipment does not heat.	Heating Element malfunction.	Replace Heating Element.
Brown function does not work.	Bake Control not set to brown setting.	Set Bake Control to brown setting.
Mist function does not operate.	Blocked or no water supply.	Turn water supply on or clean blockage.

The only user serviceable part for this appliance is the light bulb. To avoid serious injury or damage, never attempt to repair the equipment or replace a damaged power cord yourself. Do not send equipment directly to the Vollrath Company. Please contact the qualified professional repair service listed below.

VOLLRATH Technical Service • 1-800-628-0832

ELECTRICAL DRAWING - CONVECTION OVEN ~ 40703

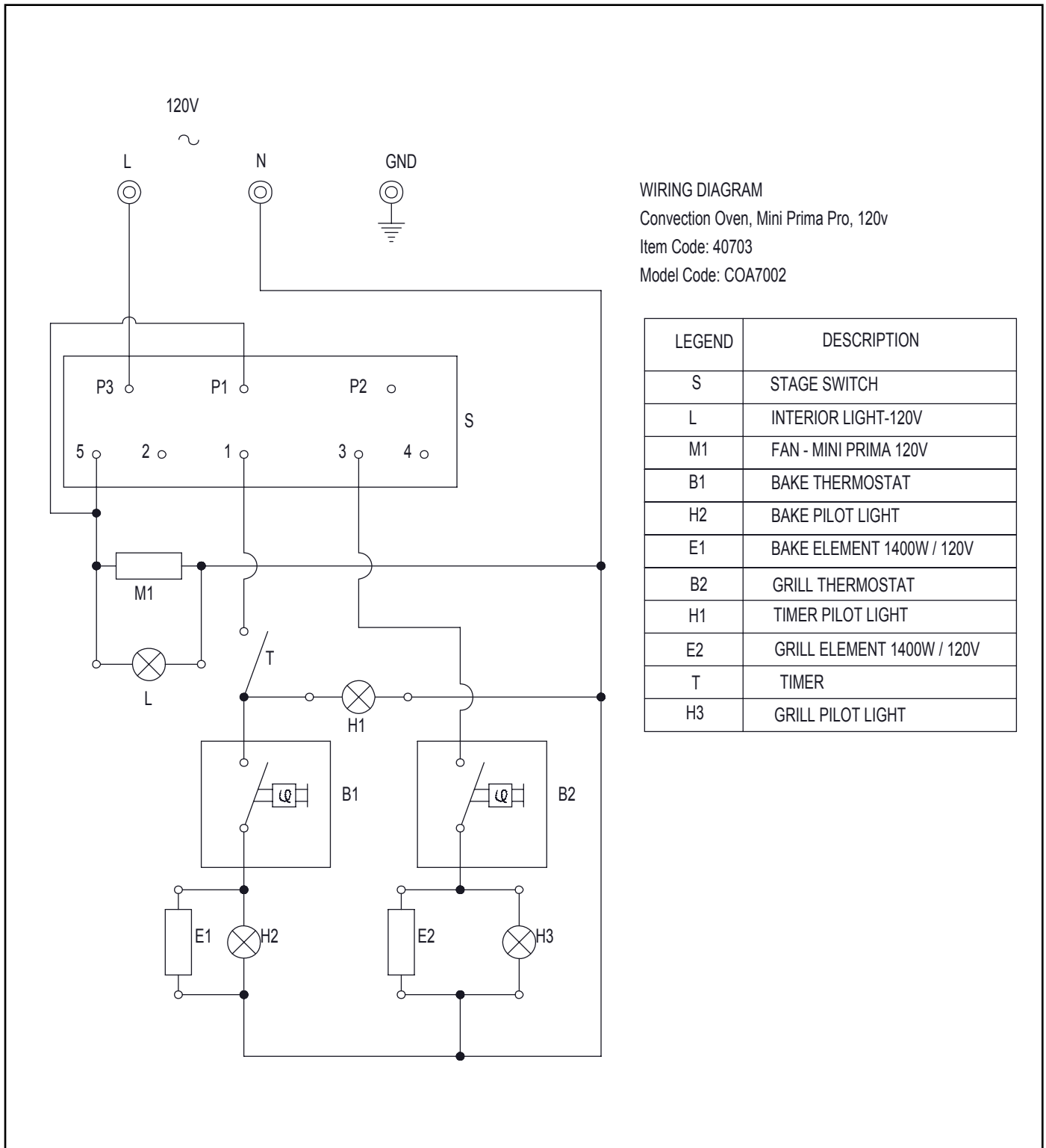

WIRING DIAGRAM

Convection Oven, Mini Prima Pro, 120v

Item Code: 40703

Model Code: COA7002

LEGEND	DESCRIPTION
S	STAGE SWITCH
L	INTERIOR LIGHT-120V
M1	FAN - MINI PRIMA 120V
B1	BAKE THERMOSTAT
H2	BAKE PILOT LIGHT
E1	BAKE ELEMENT 1400W / 120V
B2	GRILL THERMOSTAT
H1	TIMER PILOT LIGHT
E2	GRILL ELEMENT 1400W / 120V
T	TIMER
H3	GRILL PILOT LIGHT

ENGLISH

EXPLODED VIEW DRAWING - CONVECTION OVEN ~ 40701

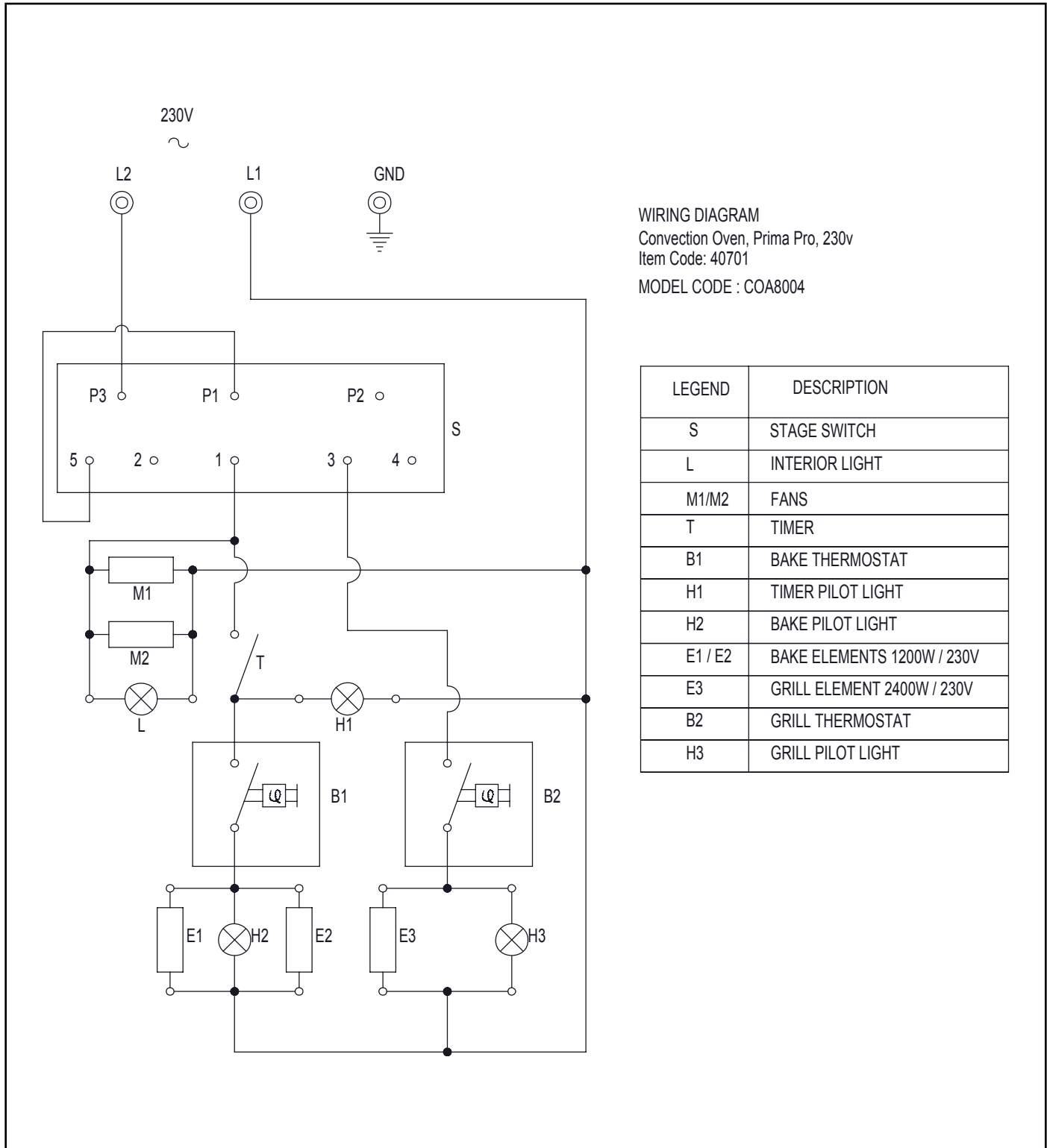

WIRING DIAGRAM
 Convection Oven, Prima Pro, 230v
 Item Code: 40701
 MODEL CODE : COA8004

LEGEND	DESCRIPTION
S	STAGE SWITCH
L	INTERIOR LIGHT
M1/M2	FANS
T	TIMER
B1	BAKE THERMOSTAT
H1	TIMER PILOT LIGHT
H2	BAKE PILOT LIGHT
E1 / E2	BAKE ELEMENTS 1200W / 230V
E3	GRILL ELEMENT 2400W / 230V
B2	GRILL THERMOSTAT
H3	GRILL PILOT LIGHT

ELECTRICAL DRAWING - CONVECTION OVEN ~ 40702

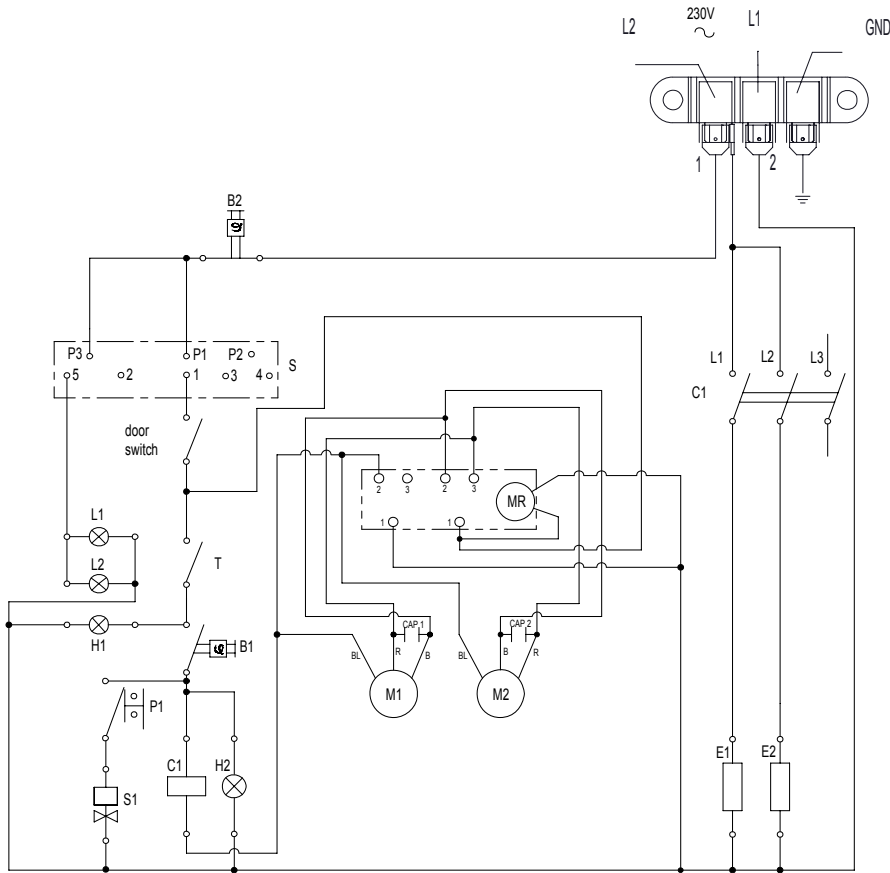

WIRING DIAGRAM
 Convection Oven, Proton
 Vollrath Model 40702
 Model Code: COA8005R02

	DESCRIPTION
B1	CONTROL THERMOSTAT
S	STAGE SWITCH
M1/M2	PROTON CATERING OVEN FAN
T	TIMER-2HR
E1/E2	CATERING OVEN ELEMENT 2800W / 230V
L1/L2	INTERIOR LIGHT
H1	TIMER PILOT LIGHT
H2	BAKING PILOT LIGHT
C1	CONTACTOR 220V COIL
B2	OVER TEMPERATURE THERMOSTAT
P1	PUSH BUTTON SWITCH
S1	SOLENOID VALVE
MR	MOTOR REVERSE TIMER
CAP1/CAP2	MOTOR CAPACITOR

MOTOR WIRE COLOURS

BL	BLUE WIRE NEUTRAL
R	RED WIRE LIVE DIRECTION
B	BLACK WIRE LIVE DIRECTION

ENGLISH

EXPLODED VIEW DRAWING - CONVECTION OVEN ~ 40703

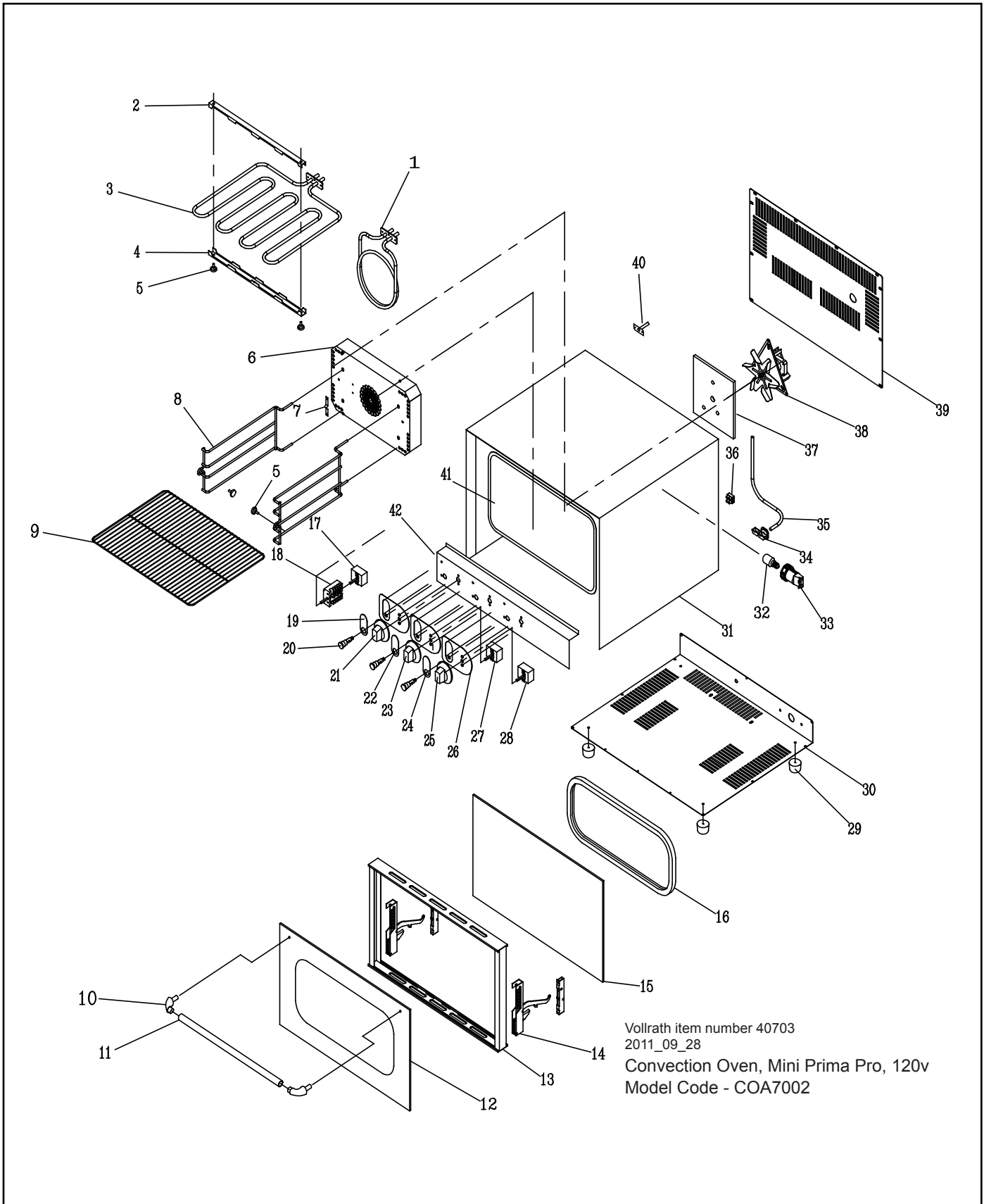

SPARE PARTS LIST - CONVECTION OVEN ~ 40703

Callout	Part Number	Description
1	XCOA3006	BAKE ELEMENT, 1400W, 110V
2	N/A	BROIL ELEMENT BRACKET
3	XCOA4005	BROIL ELEMENT, 1400W, 110V
4	N/A	ELEMENT BRACKET
5	XCOA1018	SHELF RUNNER THUMBSCREW
6	N/A	REAR ELEMENT COVER
7	N/A	PROBE CLAMP
8	XCOA4002	SHELF RUNNER
9	XCOA1016	WIRE SHELF
10	XPOA0003	PLASTIC HANDLE ELBOW
10-15	XCOA4003	COMPLETE DOOR
11	N/A	STEEL HANDLE
12	XCOA4008	OUTER GLASS
13	N/A	DOOR FRAME
14	XCOA1033	DOOR HINGE
	XCOA1010	HINGE ROLLERS
15	XCOA4007	INNER GLASS
16	XCOA4004	DOOR GASKET
17	XCOA1002	THERMOSTAT
18	XCOA1001	SELECTOR SWITCH
19	N/A	PILOT LIGHT FASCIA
20	XAA0011	PILOT LIGHT, 120V (YELLOW)
21	XCOA1005	TEMPERATURE CONTROL & BROIL SELECTOR KNOB
21	XCOA1006	TEMPERATURE CONTROL & BROIL SELECTOR KNOB (0-550) VOLLRATH BLUE
22	N/A	PILOT LIGHT FASCIA
23	XTSA0010	BROIL TEMPERATURE KNOB
23	XCOA1009	BROIL TEMPERATURE KNOB (0-550) VOLLRATH BLUE
24	N/A	PILOT LIGHT FASCIA
25	XCOA1007	TIMER KNOB
	XCOA1008	TIMER KNOB VOLLRATH BLUE
26	XAA0007	BLACK PLASTIC D SHAPE FASCIA
26	XAA0009	BLUE PLASTIC FASCIA (VOLLRATH)
27	XCOA1002	THERMOSTAT
28	XCOA1003	TIMER
29	XCOA1012	RUBBER FOOT
30	N/A	BASE COVER

Callout	Part Number	Description
31	N/A	OUTER FRAME
32	XCOA1031	LIGHT BULB(15W), 120V
33	XCOA1015	LIGHT HOLDER
34	XCOA1013	CABLE RESTRAINT
35	XAA0005	POWERCORD, 120V
36	XSAA1012	TERMINAL BLOCK
37	N/A	FAN COVER PLATE
38	XCOA3005	FAN & MOTOR, 120V, LEFT HAND THREAD
39	N/A	REAR COVER
40	N/A	EXHAUST
41	N/A	OVEN CHAMBER
42	N/A	FRONT PANEL

EXPLODED VIEW DRAWING - CONVECTION OVEN ~ 40701

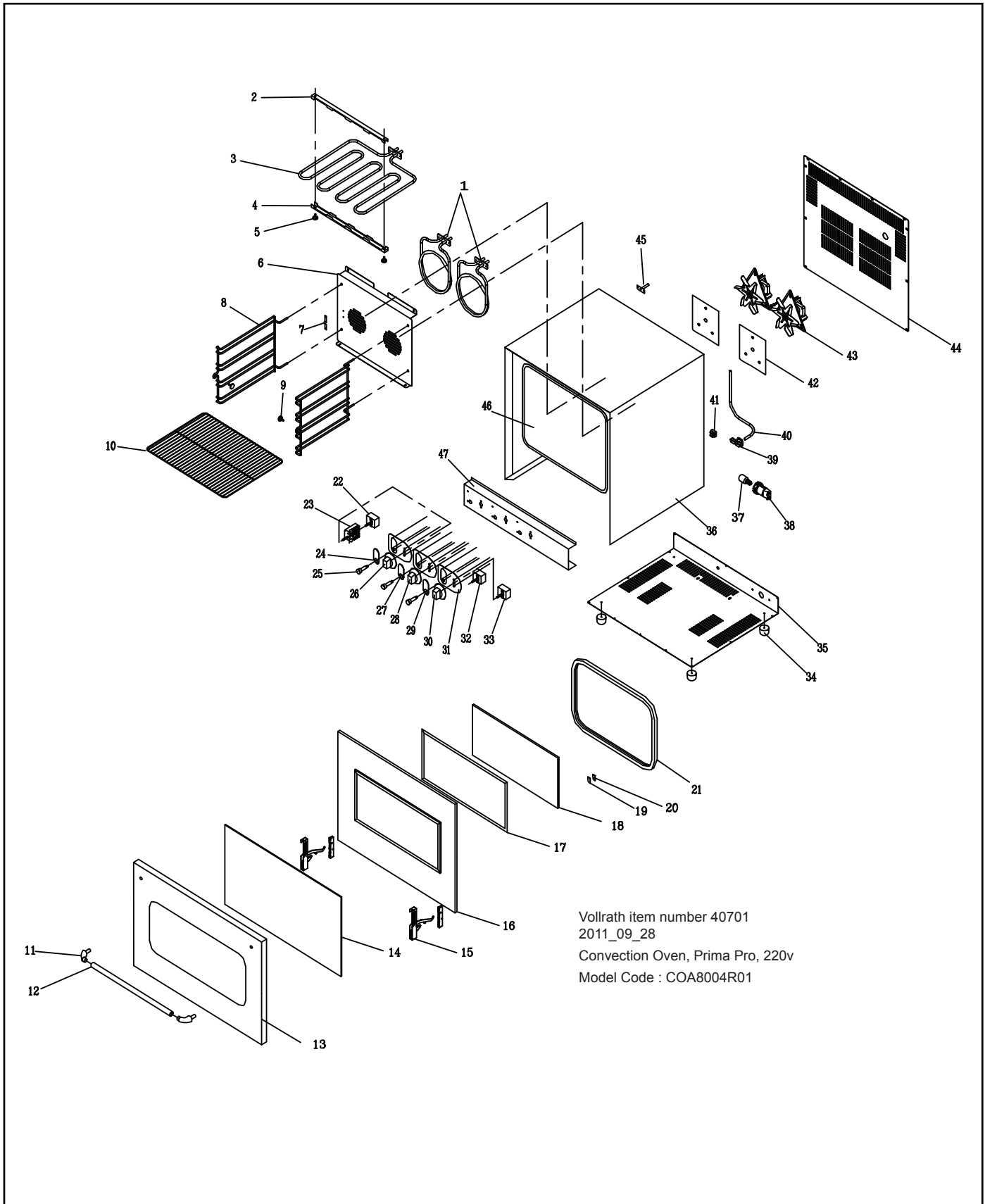

Vollrath item number 40701
 2011_09_28
 Convection Oven, Prima Pro, 220v
 Model Code : COA8004R01

SPARE PARTS LIST - CONVECTION OVEN ~ 40701

Callout	Part Number	Description
1	XCOA1019	BAKING ELEMENT, 1200W, 230V
2	N/A	GRILL ELEMENT SUPPORT
3	XCOA1020	GRILL ELEMENT
4	N/A	GRILL ELEMENT CLAMP
5	N/A	GRILL ELEMENT SCREW
6	N/A	FAN COVER
7	N/A	PROBE CLAMP
8	XCOA1017	SHELF RUNNER
9	XCOA1018	SHELF RUNNER THUMBSCREW
10	XCOA1016	WIRE SHELF
11-20	XCOA1023	COMPLETE DOOR, (INCLUDES HINGES)
11	XCOA1030	PLASTIC HANDLE ELBOW, Full Glass Door Model
11	XPOA0003	PLASTIC HANDLE ELBOW, Stainless Steel Door Trim Model
12	XCOA1025	STEEL HANDLE
13	N/A	OUTER DOOR FRAME
14	XCOA1029	OUTER GLASS, Stainless Steel Door Trim Model
15	XCOA1022	DOOR HINGE
	XCOA1010	HINGE ROLLER
16	N/A	INNER DOOR FRAME
17	N/A	INNER GLASS GASKET
18	XCOA1028	INNER GLASS, Stainless Steel Door Trim Model
19	N/A	INNER GLASS CLAMPING GASKET
20	N/A	INNER GLASS CLAMP
21	XCOA1024	DOOR GASKET
22	XCOA1002	BAKE THERMOSTAT
23	XCOA1001	SELECTOR SWITCH
24	N/A	BAKE CONTROL FASCIA
25	XAA0002	PILOT LIGHT, 230V, (RED)
26	XCOA1005	TEMPERATURE CONTROL & BROIL SELECTOR KNOB
26	XCOA1006	TEMPERATURE CONTROL & BROIL SELECTOR KNOB, (0-550) VOLLRATH BLUE
27	N/A	BROIL CONTROL FASCIA
28	XTSA0010	BROIL TEMPERATURE KNOB
28	XCOA1009	BROIL TEMPERATURE KNOB, (0-550) VOLLRATH BLUE

Callout	Part Number	Description
29	N/A	TIMER CONTROL FASCIA
30	XCOA1007	TIMER KNOB
	XCOA1008	TIMER KNOB VOLLRATH BLUE
31	XAA0007	BLACK PLASTIC D SHAPE FASCIA
31	XAA0009	BLUE PLASTIC FASCIA VOLLRATH BLUE
32	XCOA1002	GRILL THERMOSTAT
33	XCOA1003	TIMER
34	XCOA1012	RUBBER FOOT
35	N/A	BOTTOM COVER
36	N/A	OUTER CASING
37	XCOA1041	LIGHT BULB, 25W, 230V
38	XCOA1015	LIGHT HOLDER
39	XCOA1013	CABLE RESTRAINT
40	XAA0006	POWERCORD, 230V
41	XSAA1012	TERMINAL BLOCK
42	N/A	FAN MILL BOARD
43	XCOA1021	FAN & MOTOR, 230V, LEFT HAND THREAD
44	XCOA1034	REAR COVER
45	N/A	EXHAUST
46	N/A	INNER CHAMBER
47	XCOA1042	FRONT FASCIA PANEL

ENGLISH

ELECTRICAL DRAWING - CONVECTION OVEN ~ 40702

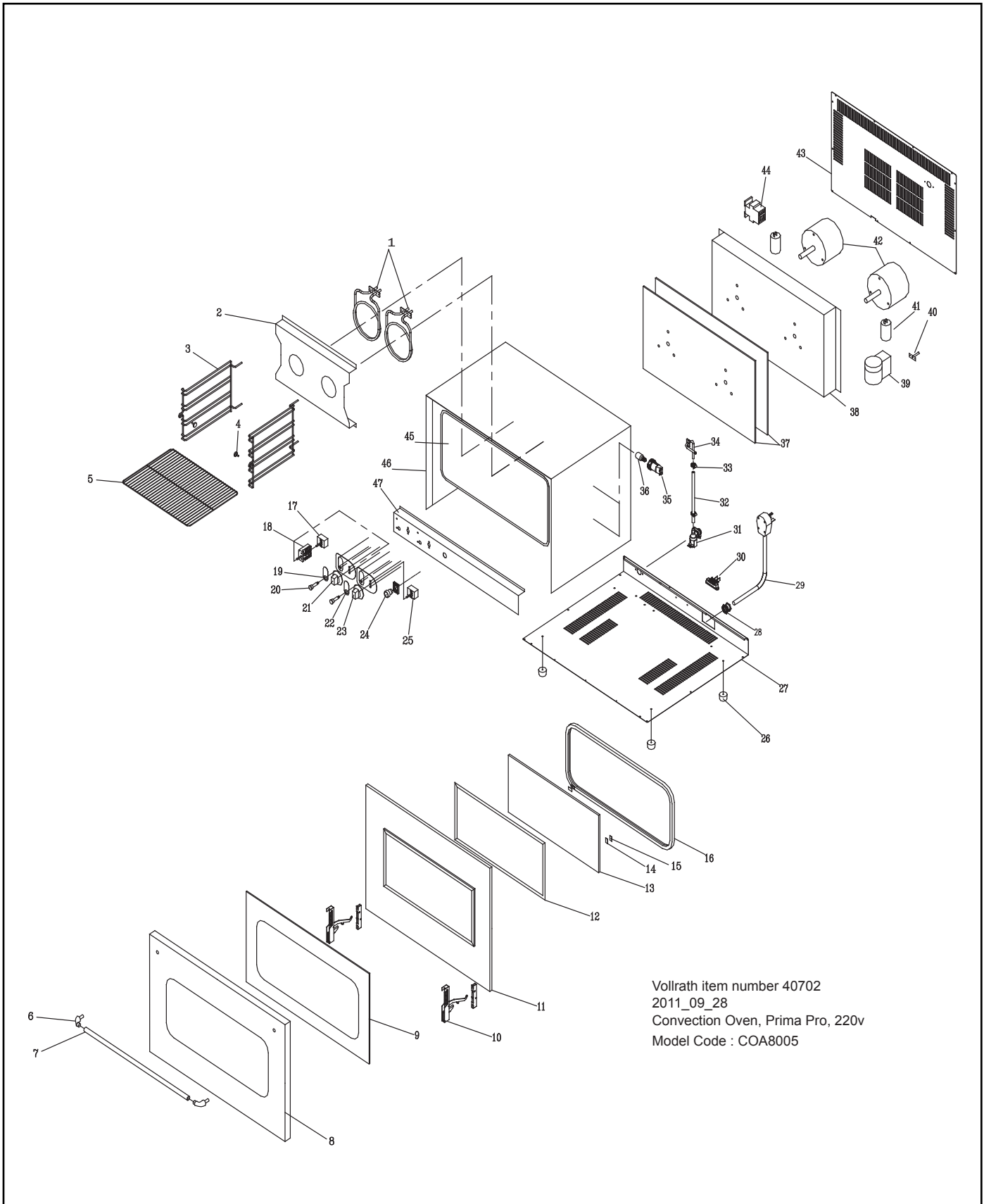

Vollrath item number 40702
 2011_09_28
 Convection Oven, Prima Pro, 220v
 Model Code : COA8005

SPARE PARTS LIST - CONVECTION OVEN ~ 40702

Callout	Part Number	Description
1	XCOA5006	BAKING ELEMENT, 2800W, 230V
3	XCOA5029	SHELF RUNNER, LEFT SIDE
	XCOA5030	SHELF RUNNER, RIGHT SIDE
4	XCOA1018	SHELF RUNNER THUMBSCREW
5	XCOA5001	WIRE SHELF
6-15	XCOA5003	COMPLETE DOOR, Stainless Steel Door Trim Model
6-15	XCOA5015	COMPLETE DOOR, Full Glass Door Model
6	XCOA1030	PLASTIC HANDLE ELBOW, Full Glass Door Model
6	XPOA0003	PLASTIC HANDLE ELBOW, Stainless Steel Door Trim Model
7	N/A	STEEL HANDLE
8	N/A	OUTER DOOR FRAME
9	XCOA5008	OUTER GLASS, Full Glass Door Model
9	XCOA5011	OUTER GLASS, Stainless Steel Door Trim Model
10	XCOA1022	DOOR HINGE, Full Glass Door Model
10	XCOA5022	DOOR HINGE, Stainless Steel Door Trim Model
	XCOA1010	HINGE ROLLER
11	N/A	INNER DOOR FRAME
12	N/A	INNER GLASS SEAL
13	XCOA5007	INNER GLASS, Full Glass Door Model
13	XCOA5010	INNER GLASS, Stainless Steel Door Trim Model
14	N/A	INNER GLASS CLAMP GASKET
15	N/A	INNER GLASS CLAMP
16	XCOA5004	DOOR GASKET
17	XCOA1002	THERMOSTAT
18	XCOA1001	SELECTOR SWITCH
19	N/A	PILOT LIGHT FASCIA
20	XAA0002	PILOT LIGHT 230V (RED)
21	XTSA0010	CONTROL KNOB
21	XCOA1009	CONTROL KNOB (0-550) VOLLRATH BLUE
	XAA0007	BLACK PLASTIC D SHAPE FASCIA
	XAA0009	BLUE PLASTIC FASCIA (VOLLRATH)
22	N/A	TIMER LIGHT FASCIA

Callout	Part Number	Description
23	XCOA1007	TIMER KNOB
23	XCOA1008	TIMER KNOB VOLLRATH BLUE
24	N/A	MIST CONTROL
25	XCOA1003	TIMER
26	XCOA1012	RUBBER FOOT
27	N/A	BASE
28	XCOA5012	CABLE RESTRAINT
29	XCOA5013	POWER CORD, NEMA6-50P PLUG
30	XFTA0002	TERMINAL BLOCK
31	XCOA5028	SOLENOID VALVE (PLUGS DIRECTLY INTO WATER MAINS)
32	N/A	12MM NYLON WATER TUBE
33	N/A	12MM HOSE CLAMP
34	N/A	WATER INJECTOR
35	XCOA1015	LIGHT HOLDER
36	XCOA1041	LIGHT BULB, 25W, 230V
37	N/A	FAN MOTOR INSULATION PAD
38	N/A	FAN MOTOR MOUNTING BOARD
39	XCOA5017	TIMER FOR REVERSABLE MOTOR (COA8005R03)
40	N/A	EXHAUST
41	N/A	CAPACITOR
42	XCOA5016	FAN & MOTOR(INCLUDES CAPACITOR) (COA8005R03)
43	N/A	REAR COVER
44	XCOA5024	CONTACTOR NC1-25
	XCOA5009	OVERTEMP THERMOSTAT (SAFETY CUT OUT)

ENGLISH

WARRANTY STATEMENT FOR THE VOLLRATH Co. L.L.C.

The Vollrath Company LLC warrants the products it manufactures and distributes against defects in materials and workmanship for a period of one year, except as specifically provided below. The warranty runs 12 months from the date of original installation. (End user receipt)

1. Refrigeration compressors – The warranty period is 5 years.
2. Refrigerated Display Cases (RDE) compressors the warranty is 3 years.
3. Replacement parts – The warranty period is 90 days.
4. Aluminum Fry pans are 90 days.
5. EverTite™ Riveting System – The warranty covers loose rivets only, lifetime to original purchaser.
6. Cayenne® Heat Strips – The warranty period is 1 year plus an additional 1 year period on heating element parts only.
7. Ultra, Ultra Fajita, Mirage® Pro and Professional Induction Ranges – The warranty period is 2 years.
8. Mirage®, Mirage® Cadet, Mirage® Fajita and Commercial Induction ranges - The warranty period is 1 year.
9. ServeWell® Induction Workstations – The warranty period is 1 year on the workstation table and 2 years on induction hobs.
10. Slicers – The warranty period is 10 years on gears and 5 years on belts.
11. Mixers – The warranty period is 2 yrs parts, 1 yr labor and belts are 5 years.
12. Vollrath – Redco products – The warranty period is 2 years.
13. Optio / Arkadia product lines – The warranty period is 90 days.
14. All non-stick products (i.e. fry pans and surfaces) are 90 days for the non stick surfaces.
15. All TRAEX® product warranty (with the exception of T-REX™) is 1 year.
16. T-REX™ product by TRAEX® is lifetime warranty.

All products in the Jacob's Pride® collection, including the following, have a lifetime warranty:

- NSF Certified One-Piece Dishers
- NSF Certified Spoodle® Utensils
- NSF Certified Heavy-Duty Spoons with Ergonomic Handle
- NSF Certified Heavy-Duty Basting Spoons
- Heavy duty Turners with Ergonomic handle
- One-Piece Tongs*
- Heavy-Duty One-Piece Ladles*
- Nylon Handle Whips
- One-Piece Skimmers
- Tribute®, Intrigue®, and Classic Select® Cookware*

*Jacob's Pride® warranty does not cover Kool-Touch®, non stick coatings and silicone handles.

All Miramar® Cookware listed below has a lifetime warranty.

- Casseroles Pans
- Oval Pans
- Sauté Pans
- French Omelet Pans
- Brazier Pans
- Stir Fry Pans
- Stir Fry Server
- Sauce Pans
- Small / Large food Pans
- French Oven
- High/Low Dome Covers

Note: Miramar® warranty does not include Buffet, Table Top Service, Templates, Decorative pans, or soup inserts

THIS WARRANTY IS IN LIEU OF ANY OTHER WARRANTIES, EXPRESS OR IMPLIED, INCLUDING ANY IMPLIED WARRANTY OF MERCHANTABILITY OR FITNESS FOR A PARTICULAR PURPOSE

As The Vollrath Company LLC's only responsibility and the purchaser's only remedy, for any breach of warranty, The Vollrath Company LLC will repair or, at its option, replace the defective product or part without charge, except as otherwise provided below:

- For refrigeration compressors and the second year of the warranty on Cayenne® Heat Strips and mixers, The Vollrath Company LLC will provide the repaired or replacement part only; and the buyer will be responsible for all labor charges incurred in performing the repair or replacement.
- To obtain warranty service, the buyer will be responsible to return to The Vollrath Company LLC any product (other than gas equipment that is permanently installed) weighing less than 110 lbs. or located outside of a 50-mile radius of a certified technician designated by The Vollrath Company LLC to perform warranty repairs. If a Vollrath Technician cannot be contacted check the website for service contact points. (Please refer to the Product Catalogue for weights and sizes of product)
- No remedy will be available for products that have been damaged by accident, carelessness, improper installation, lack of proper setup or supervision when required, neglect, improper use, installation or operation contrary to installation and operating instructions or other causes not arising out of defects in materials or workmanship. At the buyer's request, The Vollrath Company LLC will repair and or replace such products at a reasonable cost.
- No remedy will be available for slicers where blade has not been sharpened (Refer to owner's manual for sharpening instructions)
- No remedy will be available for mixers damaged by changing gears while unit is running or overloading, in either case as determined by a Vollrath Certified Technician
- Warranty work must be authorized in advance by The Vollrath Company LLC. See the operating and safety instructions for each product for detailed warranty claim procedures.
- No remedy will be available for product returned and found to be acceptable to the product specification.
- No remedy will be available under any warranty not registered as required below.

Items Not Covered Under Warranty:

- Meat Grinder Knives
- Light Bulbs in Convection Ovens, Hot Food Merchandiser and displays, Heat Lamps, and Heat Strips
- Oven Door Seals
- Oven Door Glass, Breath Guard Glass
- Hot Food Merchandisers / Display Case Glass
- Calibration and set up of gas equipment
- Manual Slicer / Dicer blades (table top food prep) – Redco and Vollrath

LIMITATION OF LIABILITY:

THE VOLLRATH COMPANY LLC SHALL HAVE NO LIABILITY FOR INCIDENTAL OR CONSEQUENTIAL DAMAGES OF ANY KIND, WHETHER BASED UPON NEGLIGENCE OR OTHER TORT, BREACH OF WARRANTY, OR ANY OTHER THEORY.

WARRANTY PROCEDURE

On all warranty calls, the following process and information is required:

- All warranty claims will start with a call to Vollrath Technical Service support line.(800-628-0832).
- A technical support professional will work to diagnose the issues, and provide the details for the service solution.
- Name and phone number of person calling
- Business name, street address, city, state and zip
- Model and serial number
- Date of purchase and proof of purchase (Receipt)
- Name of dealer where unit was purchased

NOTE: Vollrath will not accept products sent without the proper procedure being followed.

Important:

TO MAKE A CLAIM FOR ANY REMEDY UNDER THIS WARRANTY, YOU MUST REGISTER YOUR WARRANTY.

REGISTER TODAY

ONLINE: Register your warranty on-line now at www.Vollrathco.com

NO WEB ACCESS: If you do not have access to the web, kindly register by completing the warranty registration form and faxing it to The Vollrath Co. LLC office in the country of purchase.

WARRANTY REGISTRATION			
BUSINESS NAME			
KEY CONTACT NAME		EMAIL	
STREET ADDRESS			
CITY	STATE	ZIP CODE	
COUNTRY	PHONE	FAX	
MODEL		ITEM NUMBER	
SERIAL NUMBER	<input type="text"/>	-	<input type="text"/>
OPERATION TYPE			
<input type="checkbox"/> Limited Service Restaurant	<input type="checkbox"/> Full Service Restaurant	<input type="checkbox"/> Bars and Taverns	<input type="checkbox"/> Supermarket
<input type="checkbox"/> Convenience Store	<input type="checkbox"/> Recreation	<input type="checkbox"/> Hotel/Lodging	<input type="checkbox"/> Airlines
<input type="checkbox"/> Business/Industry	<input type="checkbox"/> Primary/Secondary School	<input type="checkbox"/> Colleges/University	<input type="checkbox"/> Hospitals
<input type="checkbox"/> Long-Term Care	<input type="checkbox"/> Senior Living	<input type="checkbox"/> Military	<input type="checkbox"/> Corrections
REASON FOR SELECTING OUR PRODUCT			
<input type="checkbox"/> Appearance	<input type="checkbox"/> Full Service Restaurant	<input type="checkbox"/> Availability	<input type="checkbox"/> Sellers Recommendation
<input type="checkbox"/> Ease of Operation	<input type="checkbox"/> Versatility of Use	<input type="checkbox"/> Price	<input type="checkbox"/> Brand
WOULD YOU LIKE TO RECEIVE OUR FULL-LINE CATALOG AND REMAIN ON OUR MAILING LIST?			<input type="checkbox"/> Yes <input type="checkbox"/> No

ENGLISH



www.vollrathco.com

The Vollrath Company, L.L.C.
1236 North 18th Street
Sheboygan, WI 53081-3201
U.S.A.

Main Tel: 920.457.4851
Fax: 800.752.5620

Technical Services: 800.628.0832
Service Fax: 920.459.5462

Canada Service: 800.695.8560

© 2013 The Vollrath Company, L.L.C.
