

VOLLRATH THERMOSTAT GAS GRIDDLE, 60", HEAVY DUTY, 1" THICK PLATE

ITEM NO./MODEL NO.	DESCRIPTION
GGHDT-60	THERMOSTAT GAS GRIDDLE, 60", HEAVY DUTY, 1" THICK PLATE

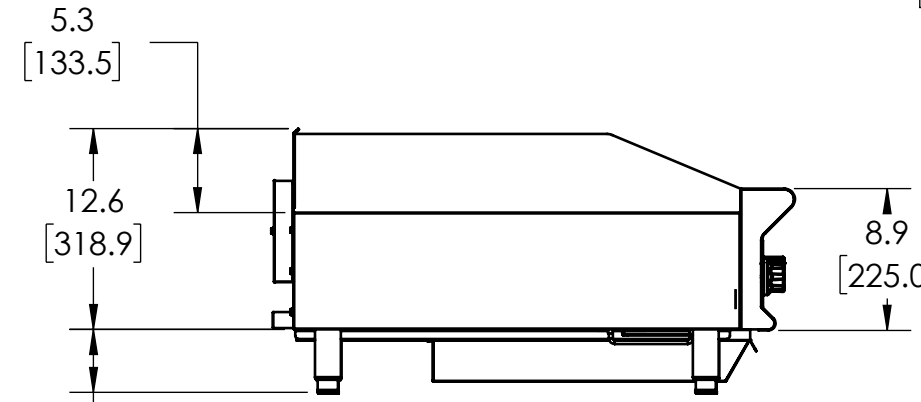
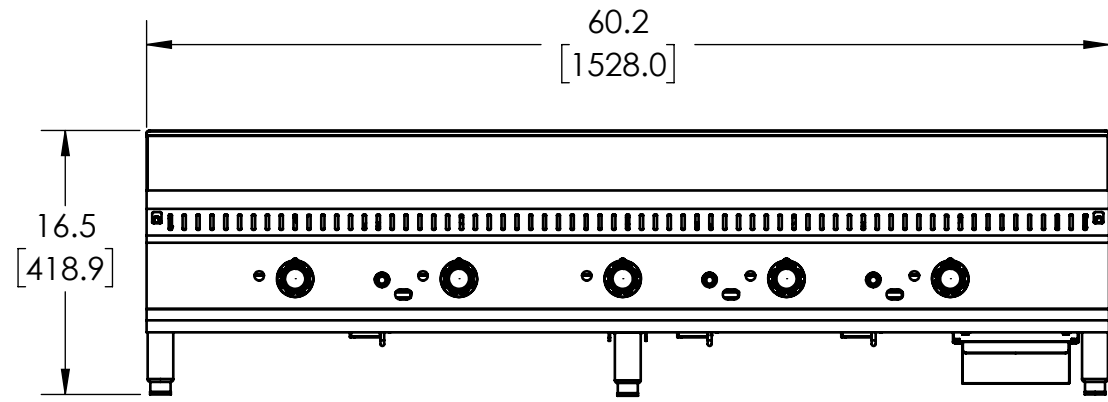

4.0 - 5.5
[101.6 - 139.7]

NOTE:

1. OUTPUT IS 150,000 BTU.
2. UNIT SHOULD BE INSTALLED UNDER A HOOD IN ACCORDANCE WITH THE LATEST EDITION OF THE STANDARD FOR VENTILATION CONTROL AND FIRE PROTECTION OF COMMERCIAL COOKING OPERATIONS, NFPA 96.
3. STANDING PILOTS WITH A MANUAL BURNER CONTROL VALVE FOR EACH BURNER. 3/4" NPT GAS INLET.
4. UNIT WEIGHT IS: 546.7 LBS.
5. MATERIALS: STAINLESS STEEL AND PRE-SEASONED CAST IRON.
6. CERTIFICATIONS:
 1. ANSI Z83.11:2016.
 2. CSA 1.8:2016.
 3. NSF/ANSI 4.

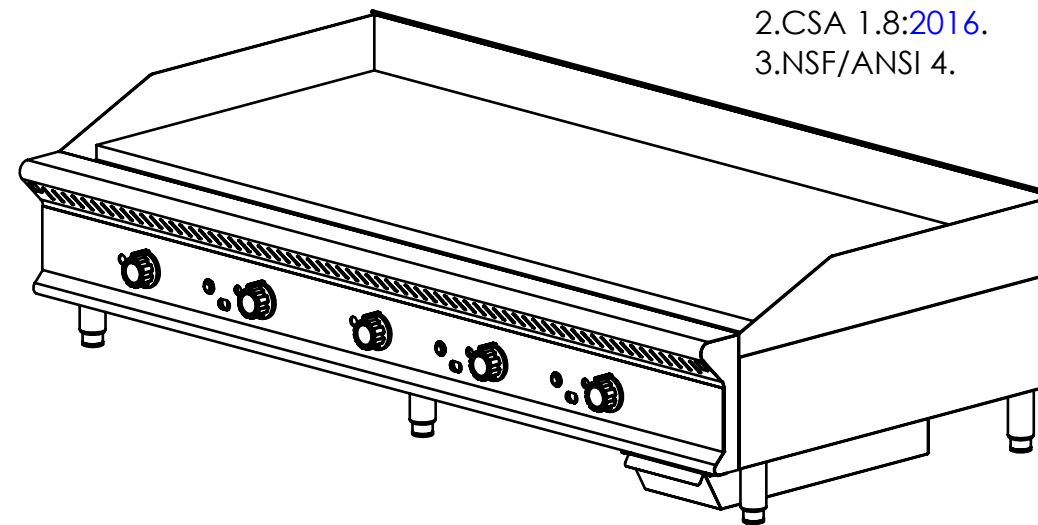
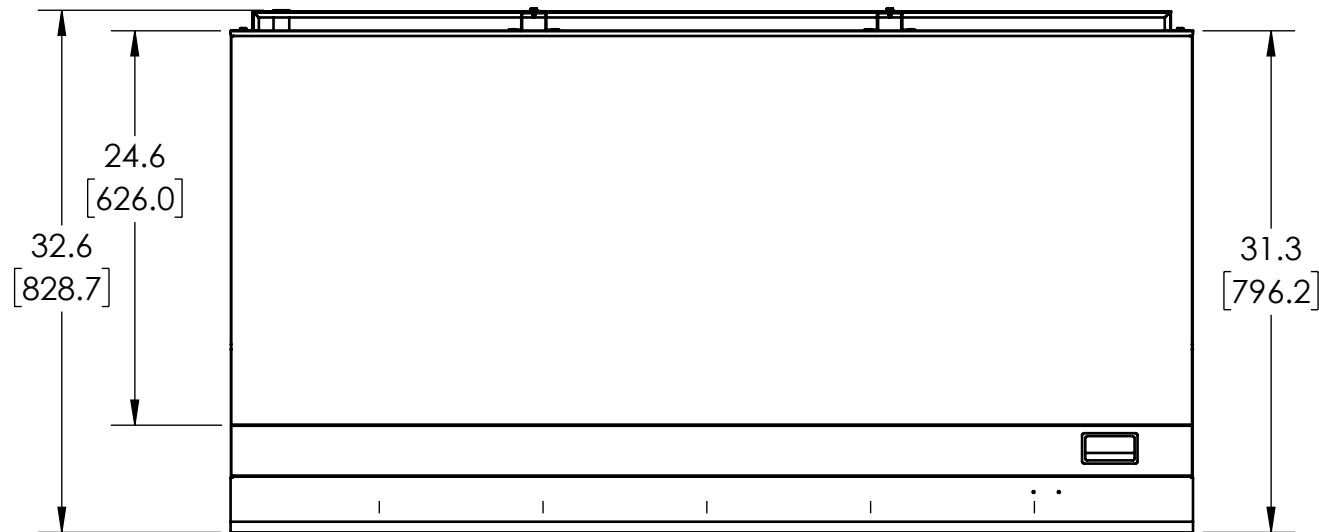

DIMENSIONS ARE IN INCHES (IN) UNLESS OTHERWISE NOTED.
DIMENSIONS IN BRACKETS ARE IN MILLIMETERS (MM) AND ARE FOR REFERENCE ONLY.

ITEM NO./MODEL NO.	DESCRIPTION
GGHDT-60	THERMOSTAT GAS GRIDDLE, 60", HEAVY DUTY, 1" THICK PLATE

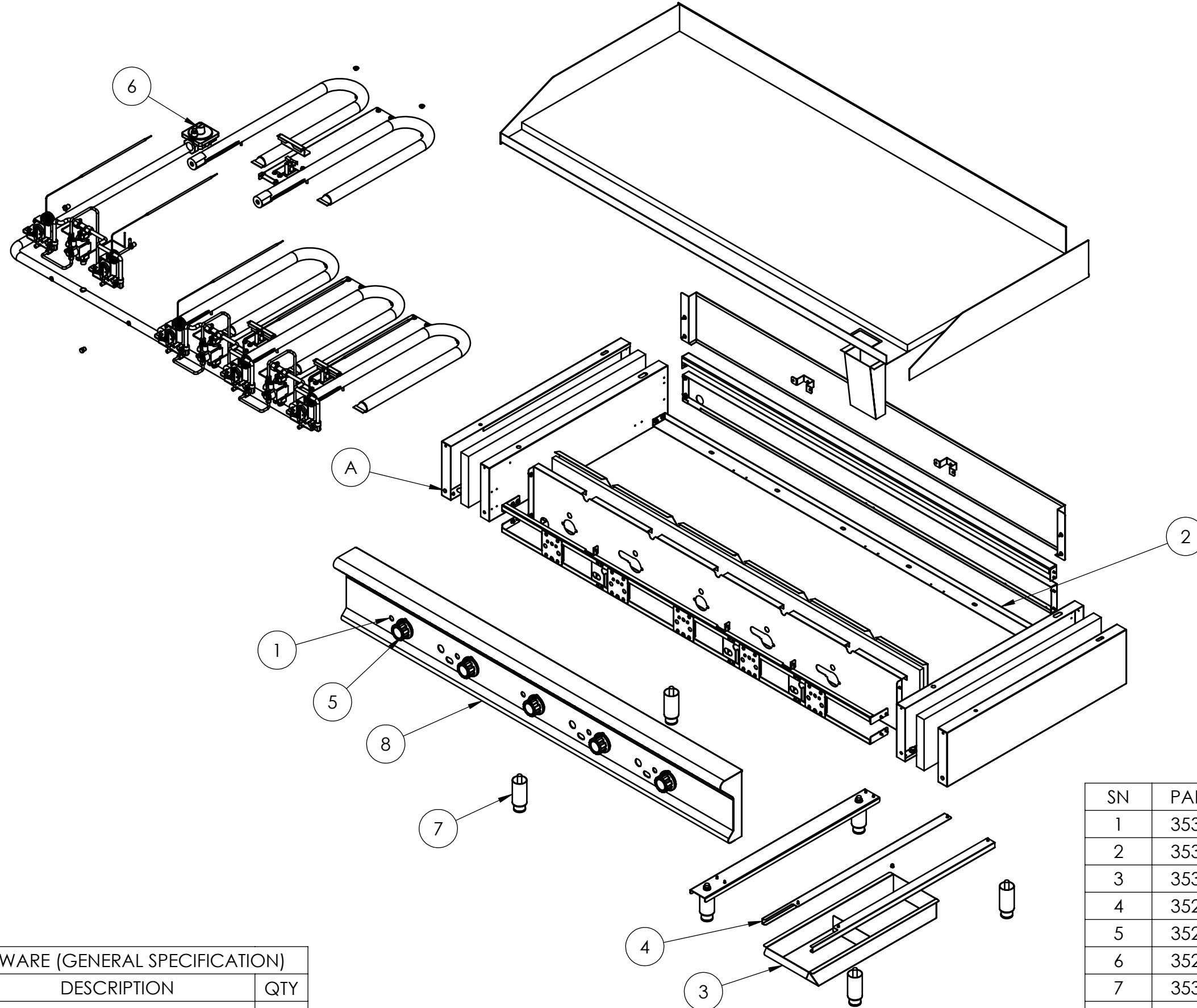

HARDWARE (GENERAL SPECIFICATION)		
SN	DESCRIPTION	QTY
A	M5X0.8X10 SS TAP SCREW, FL HEX	42

SN	PART NO	DESCRIPTION	QTY
1	353480-1	FASCIA - 60IN HDT GRIDDLE	1
2	353403-1	BURNER SUPPORT - 60IN GRIDDLE	1
3	353386-1	DRIP TRAY - GRIDDLE	1
4	352506-1	DRIP TRAY SUPPORTS - HD GD	1
5	352495-1	CONTROL KNOB SM INSERT	5
6	352509-1	REGULATOR 5IN WC	1
7	353376-1	LEG, GAS APPLIANCE	6
8	354239-1	GGHDT-60 FRONT PANEL ASSY	1

ITEM NO./MODEL NO.	DESCRIPTION
GGHDT-60	THERMOSTAT GAS GRIDDLE, 60", HEAVY DUTY, 1" THICK PLATE

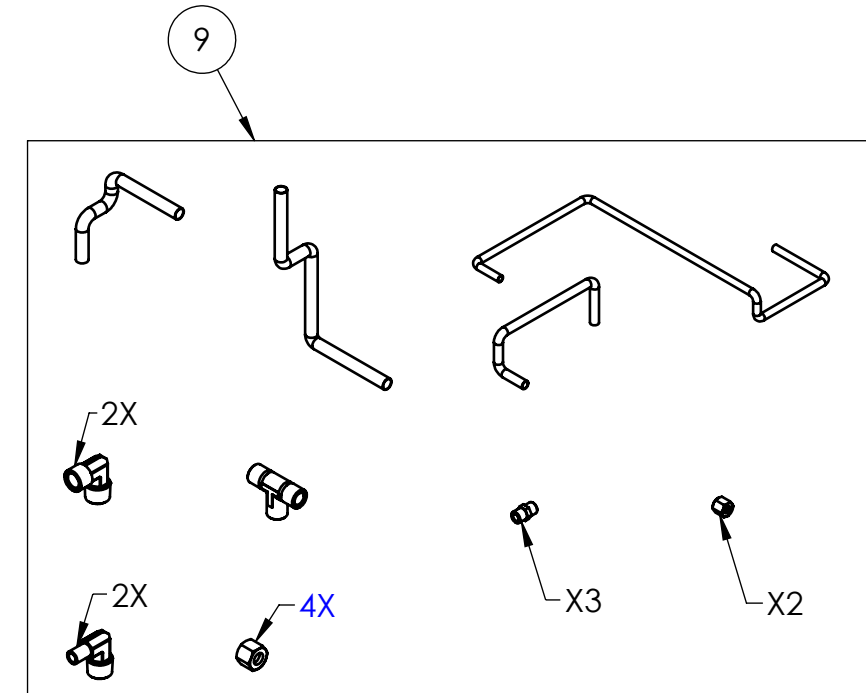
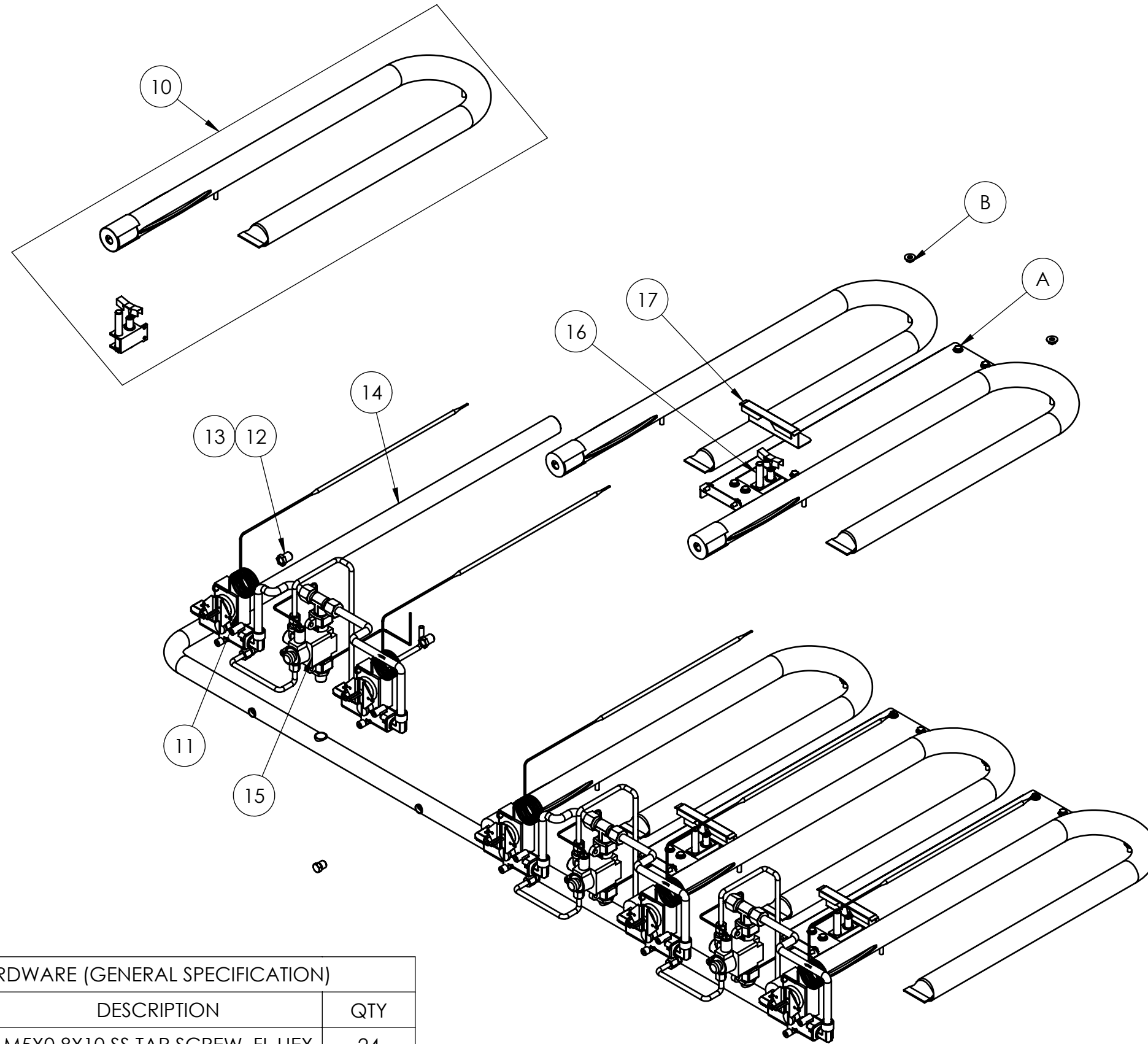

*NOTE: ONLY ONE TYPE OF ORIFICE IS REQUIRED, 2.35MM FOR NATURAL GAS OR 1.60MM FOR LP

HARDWARE (GENERAL SPECIFICATION)		
SN	DESCRIPTION	QTY
A	M5X0.8X10 SS TAP SCREW, FL HEX	24
B	M5X0.8X4 SS HEX NUT	17

SN	PART NO	DESCRIPTION	QTY
9	353477-1	HD VALVE CONNECTORS ASSY	3
10	353474-1	BURNER/PILOT ASSY - HDT GAS GRID	5
11	353475-1	HD GST VALVE ASSY	5
12	353440-1	2.35MM BRASS ORIFICE	5
13	353369-1	1.60MM BRASS ORIFICE	5
14	352498-1	MANIFOLD - 60IN HDT GRIDDLE	1
15	352500-1	HDT GRIDDLE SAFETY VALVE	3
16	352501-1	HDT GRIDDLE THERMOCOUPLE	3
17	352547-1	HDT PILOT DIVERTER	3