

**VOLLRATH** MANUAL GAS GRIDDLE, 18", MEDIUM DUTY, 3/4" THICK PLATE

ITEM NO./MODEL NO.	DESCRIPTION
GGMDM-18	MANUAL GAS GRIDDLE, 18", MEDIUM DUTY, 3/4" THICK PLATE

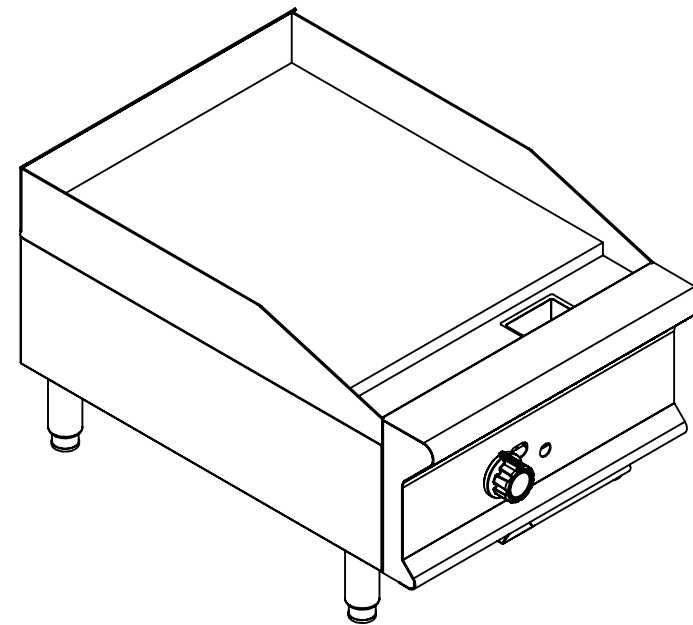
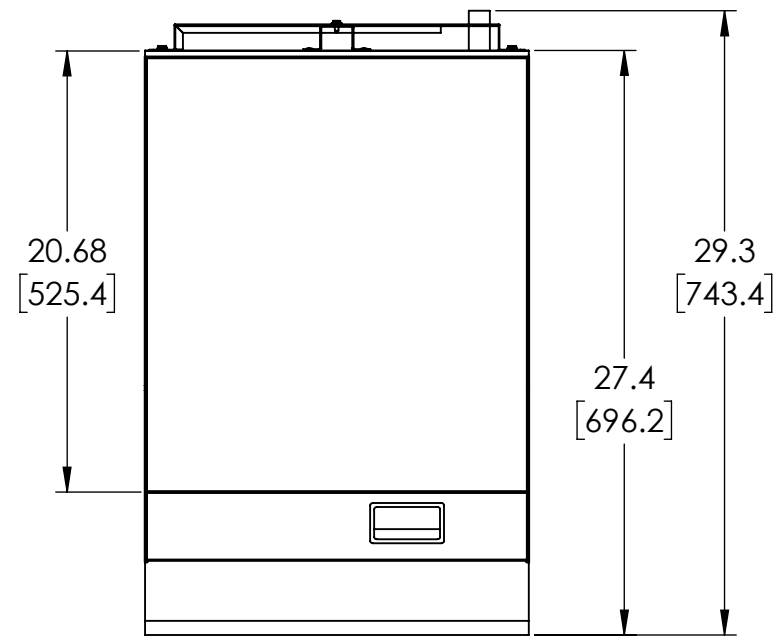
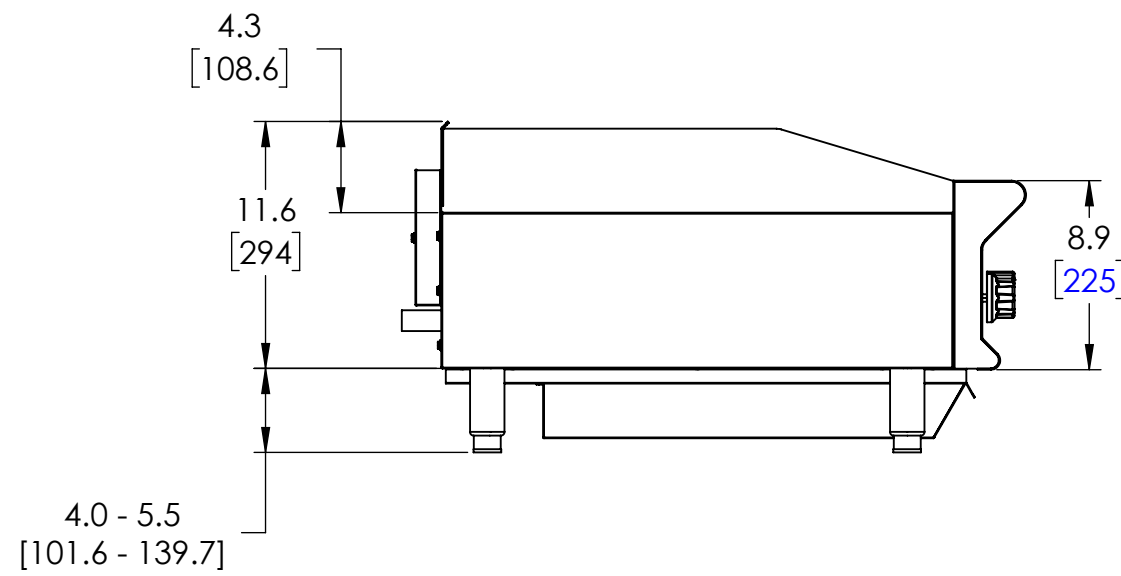
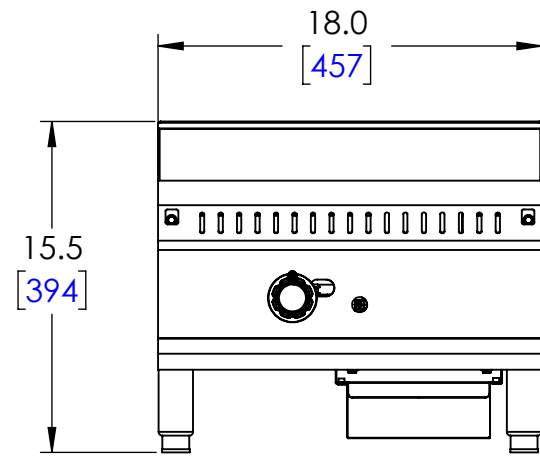

NOTE:

1. OUTPUT IS 28,000 BTU.
2. UNIT SHOULD BE INSTALLED UNDER A HOOD IN ACCORDANCE WITH THE LATEST EDITION OF THE STANDARD FOR VENTILATION CONTROL AND FIRE PROTECTION OF COMMERCIAL COOKING OPERATIONS, NFPA 96.
3. STANDING PILOTS WITH A MANUAL BURNER CONTROL VALVE FOR EACH BURNER. 3/4" NPT GAS INLET.
4. UNIT WEIGHT IS: 131.18 LBS.
5. MATERIALS: STAINLESS STEEL AND PRE-SEASONED CAST IRON.
6. CERTIFICATIONS:
  1. ANSI Z83.11:2016.
  2. CSA 1.8:2016.
  3. NSF/ANSI 4.

DIMENSIONS ARE IN INCHES (IN) UNLESS OTHERWISE NOTED.  
 DIMENSIONS IN BRACKETS ARE IN MILLIMETERS (MM) AND ARE FOR REFERENCE ONLY.

ITEM NO./MODEL NO.	DESCRIPTION
GGMDM-18	MANUAL GAS GRIDDLE, 18",MEDIUM DUTY, 3/4" THICK PLATE

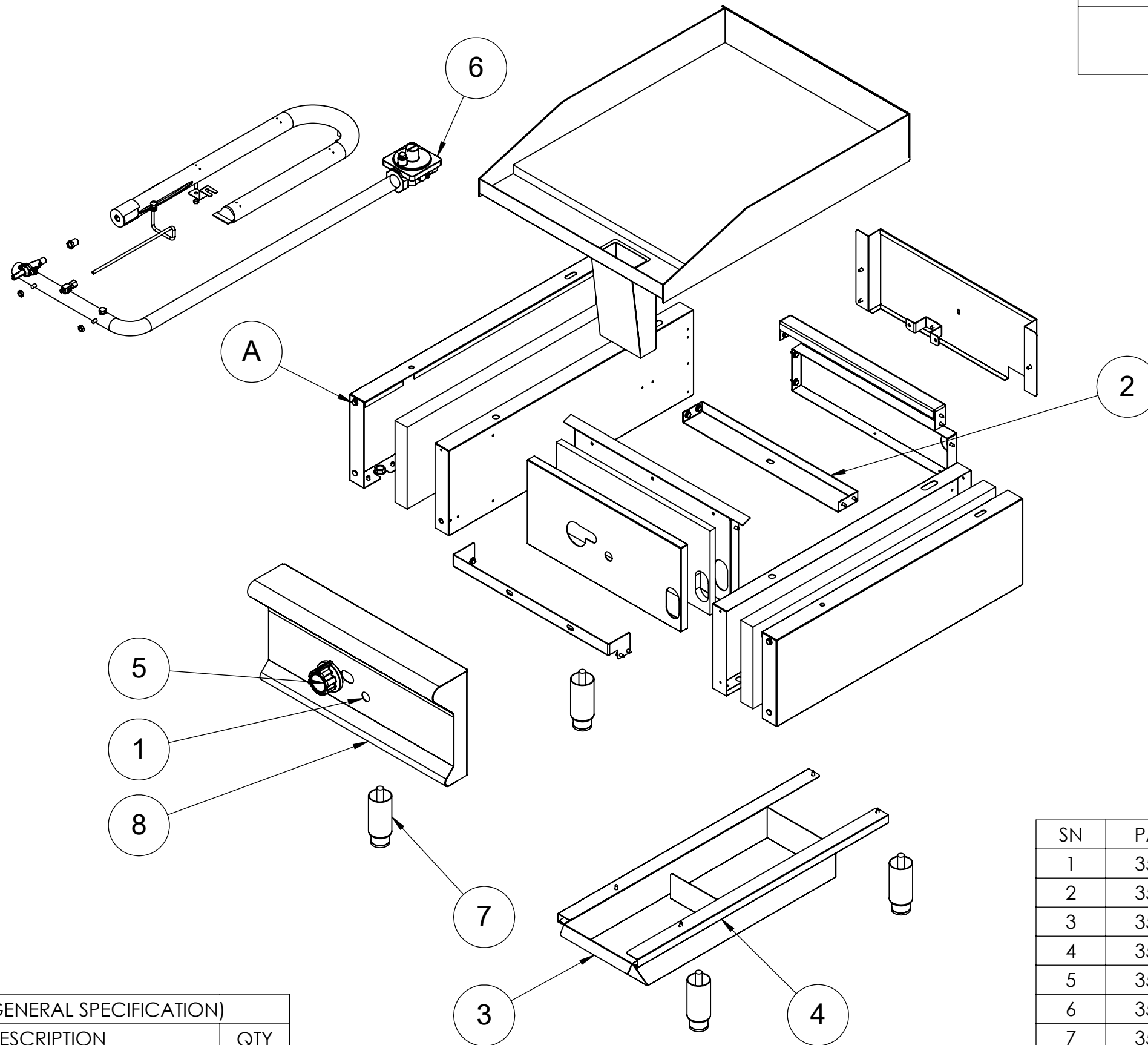

HARDWARE (GENERAL SPECIFICATION)		
SN	DESCRIPTION	QTY
A	M5X0.8X10 SS TAP SCREW, FL HEX	33

SN	PART NO	DESCRIPTION	QTY
1	353390-1	FASCIA - 18IN MDM GRIDDLE	1
2	353391-1	BURNER SUPPORT - 18IN GRIDDLE	1
3	353386-1	DRIP TRAY - GRIDDLE	1
4	353375-1	DRIP TRAY SUPPORTS - MD GD	1
5	353373-1	CONTROL KNOB LG INSERT	1
6	353374-1	REGULATOR 4IN WC	1
7	353376-1	LEG, GAS APPLIANCE	4
8	354219-1	GGMDM-18 FRONT PANEL ASSY	1

ITEM NO./MODEL NO.	DESCRIPTION
GGMDM-18	MANUAL GAS GRIDDLE, 18",MEDIUM DUTY, 3/4" THICK PLATE

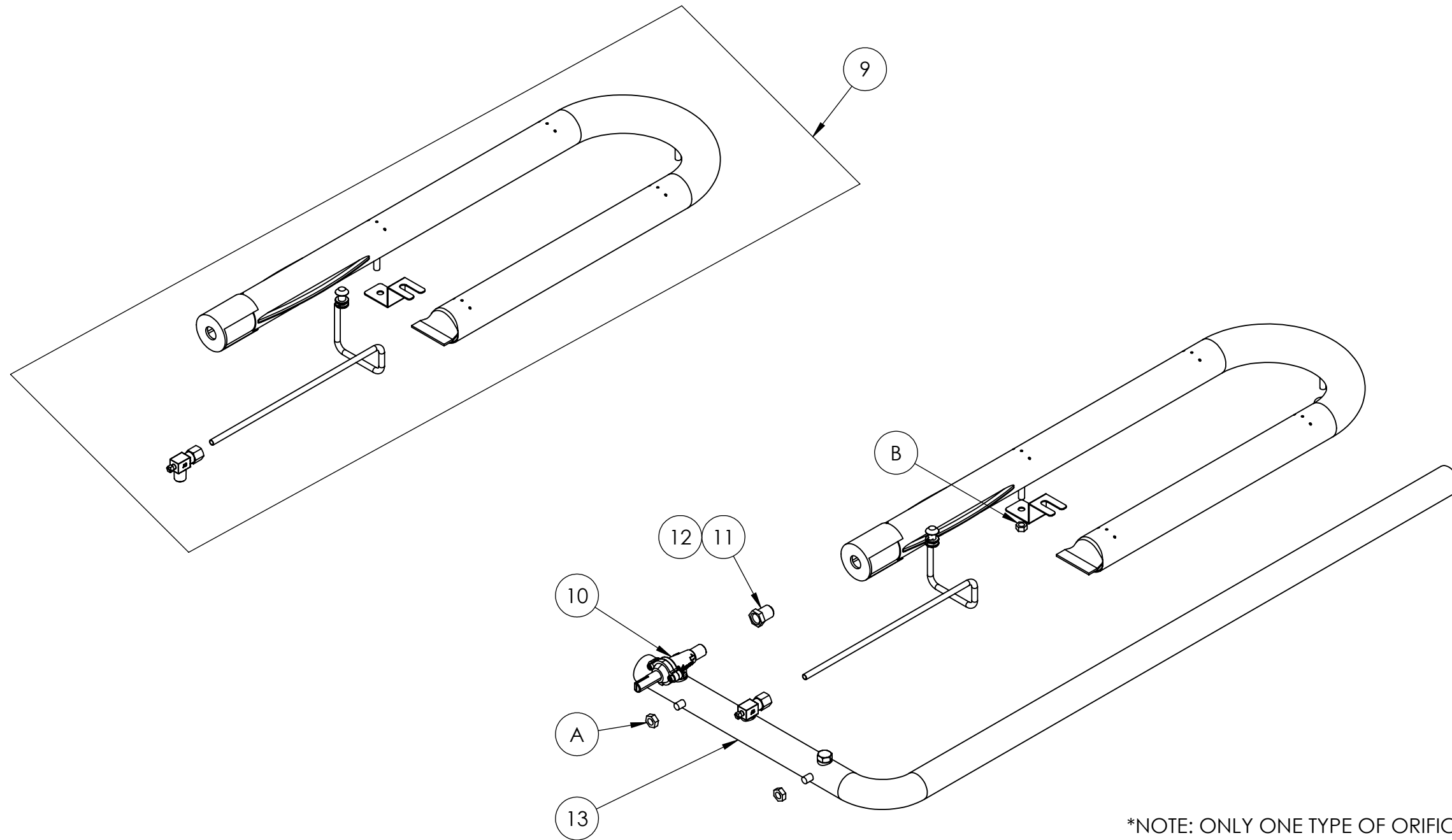

\*NOTE: ONLY ONE TYPE OF ORIFICE IS REQUIRED, 2.44MM FOR NATURAL GAS OR 1.61MM FOR LP

HARDWARE (GENERAL SPECIFICATION)		
SN	DESCRIPTION	QTY
A	M6X1X5 SS HEX NUT	2
B	M5X0.8X4 SS HEX NUT	2

SN	PART NO	DESCRIPTION	QTY
9	353385-1	BURNER/PILOT ASSY - MDM GAS GR	1
10	353367-1	MANUAL CONTROL VALVE	1
11	353387-1	2.44MM BRASS ORIFICE *	1
12	353388-1	1.61MM BRASS ORIFICE *	1
13	353392-1	MANIFOLD - 18IN MDM GRIDDLE	1