

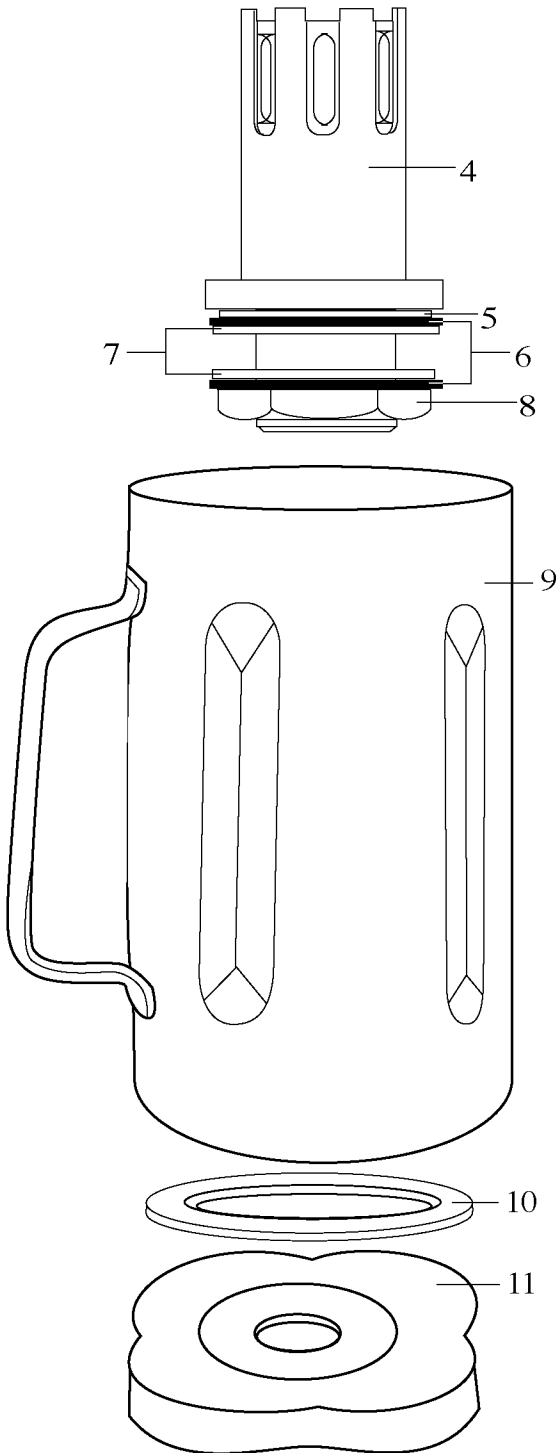

LC101

High Shear Stainless Steel Container

300ML to 850ML working capacity
Flow/thru centrifugal blending assembly



501881
Container with Blending Assembly

Illustration#	Part#	Description
1	013617	Actuator Switch Nut
2	020491	Screw
3	017324	Lid
4	018649	Blade Assy.
5	009724	Washer /nylon
6	003537	Washer /stainless steel
7	003509	Washer /neoprene
8	009780	Hex Nut /left handed thread
9	012860	32 oz. Stainless Steel Container
10	009762	Gasket
11	015055	Container Adapter