

**Container Information**  
500 ml Working Capacity  
Unique Blade for Dry  
Homogenizing and Pulverizing

**WARING**  
**COMMERCIAL**  
**SS115**  
Dry Blending Container

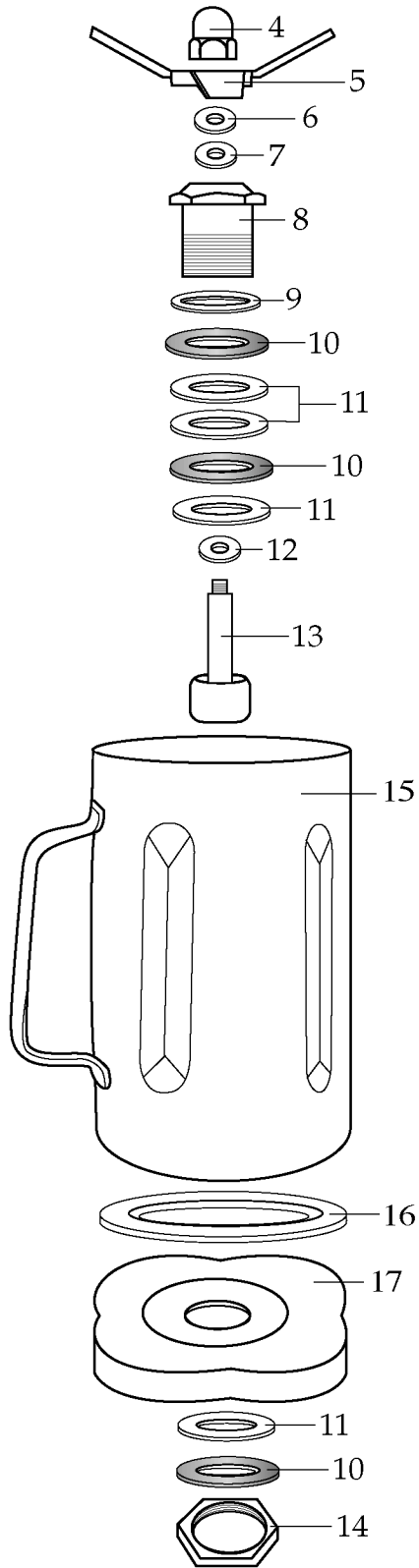

Illustration#	Part#	Description
1	013617	Actuator Switch Nut
2	020491	Screw
3	017324	Jar Lid
4	003504	Cap Nut
5	024225	Blade
6	003609	Washer /stainless steel
7	003508	Washer /fairprene
8	010012	Bearing Holder
9	009724	Washer /nylon
10	003537	Washer /stainless steel 3 Req.'d
11	003509	Washer /neoprene (rubber) 4 Req.'d
12	003510	Washer /fiber
13	002406	Socket Head Drive Shaft
14	009780	Hex Nut
15	012860	32 Oz. Stainless Steel Container
16	009762	Gasket
17	015055	Container Adapter