



# Multi-Function Oven

Salamander / Baker / Oven

Item No: **54016**

120V~60 Hz, 1750W, 14.6A



**WARNING ELECTRICAL SHOCK HAZARD.**

**FAILURE TO FOLLOW THESE INSTRUCTIONS COULD RESULT IN SERIOUS INJURY OR DEATH.**

**WARNING:** Handling the cord on this product may expose you to lead, a chemical known to the State of California to cause cancer and birth defects or other reproductive harm. WASH HANDS AFTER HANDLING.

Electrical ground is required on this appliance.

1. Do not modify the power supply cord plug. If it does not fit the outlet, have a proper outlet installed by a qualified electrician.
2. Do not use an extension cord with this appliance.
3. Check with a qualified electrician if you are in doubt as to whether the appliance is properly grounded.

## SAFETY INSTRUCTIONS

1. Plug electrical cord into a certified electrical outlet with a corresponding voltage rating as listed on the machine model labels.
2. Always unplug the electric cord when appliance is not in use and before cleaning, adjusting or maintaining this steamer. Do not operate with a damaged cord or plug or after the machine malfunctions, has been dropped or damaged. Use authorized service for examination, electrical or mechanical adjustment or repair.
3. This equipment will be HOT during use and for a short time after it is turned off. BE CAREFUL. To avoid burns, do not let bare skin touch hot surfaces. If provided, use handles when moving this appliance. Keep combustible materials away from appliance.
4. Extreme caution is necessary when any appliance is used by or near children and whenever the appliance is left operating and unattended.
5. This appliance is not intended for use in wet locations. Never locate appliance where it may fall into a water container.  
Do not insert or allow foreign objects to enter any ventilation or exhaust opening as this may cause an electrical shock, fire or damage to the appliance.

## Assembly Instructions

1. Remove any packaging materials.
2. Plug in to a properly grounded 120V outlet.
3. It is recommended to perform an initial burn off before using. Set oven to 550°F and let it bake for approximately one hour.

## Operating Instructions

1. Plug the machine into a properly grounded 120 volt outlet.
2. Choose which circuit you would need for your products. There is an “Always On” or a “Timer Controlled” circuit.
3. Set the thermostat to desired temperature. Refer to product instructions.
4. Power on the heating elements inside the oven using the individual switches. You have the option of using both the top and bottom heaters or only using one or the other. The oven can be utilized as a salamander, toaster, or an oven.
5. Allow oven to preheat for approximately 10 mins.
6. The timer can be used during either circuit. In the “Always On” circuit, the timer is simply a timer. In the “Timer Controlled” circuit, the heaters will only operate while timer is on.

## Cleaning

1. Turn off the machine and unplug it from the power source.
2. Remove any remaining food product from the cabinet and dump the crumb tray.
3. The baking rack and crumb tray can be washed using soapy water.
4. Clean the stainless steel cabinet outer panels with damp cloth and mild detergent.
5. Return the baking rack and crumb tray to the oven.

## Oven Functions

Top Heater	Bottom Heater	Always On	Timer Controlled	Function
ON	OFF	Continuous Heat	For Duration of Timer	Salamander
OFF	ON	Continuous Heat	For Duration of Timer	Baking
ON	ON	Continuous Heat	For Duration of Timer	Oven

## Wiring Diagram

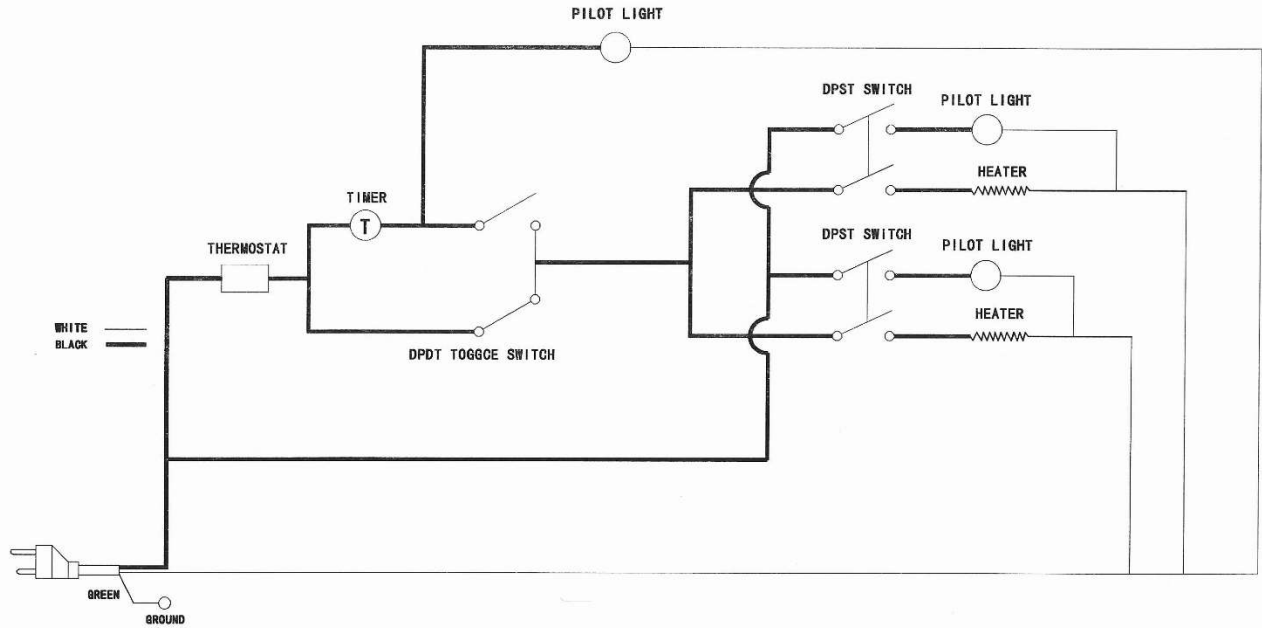

## Diagram

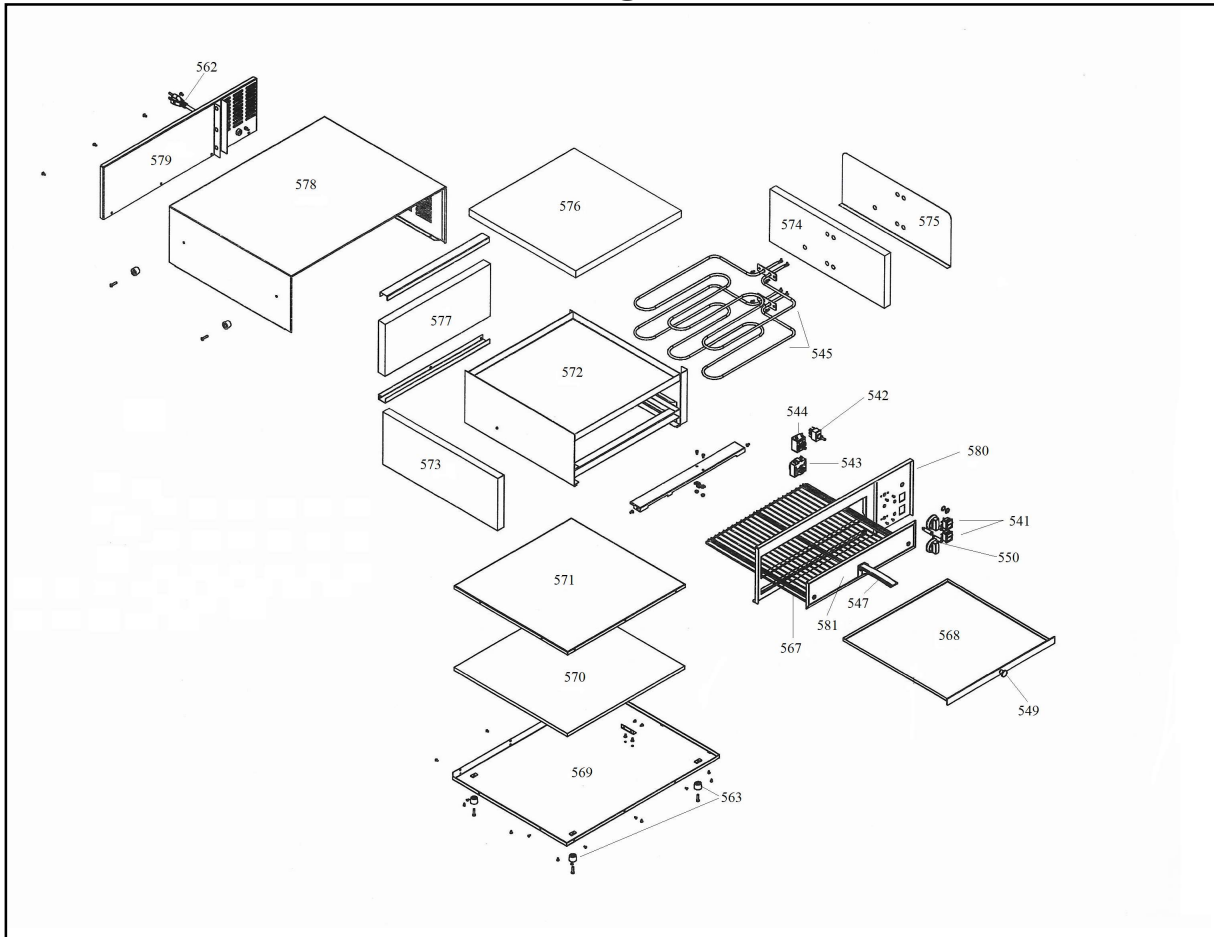

## Parts List

Part #	Description
541	Heater Switch
542	Circuit Switch
543	Oven Timer
544	Adjustable Thermostat
545	Heating Element
567	Baking Rack
547	Handle
568	Crumb Tray
549	Crumb Tray Handle
550	LED
569	Bottom Panel
570	Bottom Insulation

Part #	Description
571	Bottom Chassis Panel
572	Oven Chassis
573	Left Panel Insulation
574	Right Panel Insulation
575	Right Panel Cover
576	Top Insulation
577	Back Insulation
578	Top Panel
579	Back Panel
562	Power Cord
563	Rubber Feet
580	Front Control Panel