



Series 3

Models 550 and 750 MBH
Commercial Condensing
Gas-fired water boilers

Boiler Manual

- Installation
- Maintenance
- Startup
- Parts



WARNING

This manual must only be used by a qualified heating installer/service technician. Read all instructions, including this manual and all other information shipped with the boiler, before installing. Perform steps in the order given. Failure to comply could result in severe personal injury, death or substantial property damage.



The SlimFit® Series 3 COMMERCIAL gas-fired water boiler

1 Cast aluminum sectional heat exchanger

2 Heat exchanger cleanout plate

3 Blower

Air enters the boiler enclosure through the air intake adapter (18), flows through the enclosure, enters the air inlet silencer (5), then enters the venturi (6). The blower pulls air and gas through the venturi and pushes the mixture into the burner. The advanced blower design and air inlet silencer yield very quiet operation.

3a Blower motor

4 Automatic gas valve

The automatic gas valve incorporates two solenoid-operated valve seats. The valve senses the vacuum in the venturi (item 6) caused by flowing air. Gas flows in proportion to air flow, so fuel/air ratio remains constant as blower speed/air flow changes.

5 Air inlet silencer

The horn-shaped air inlet silencer significantly reduces fan noise, providing exceptionally quiet operation.

6 Venturi

When air flows through the venturi, it creates a vacuum that is sensed by the gas valve to regulate gas flow (see item 4).

7 Control module (see discussion upper right)

8 Expansion module

The expansion module operates the gas valve, monitors gas pressure switches and provides a dry contact for the boiler circulator (suitable for up to 10 amps). Connections for BMS and Boiler-to-Boiler communications also located on board.

10 Electronic display & buttons

The electronic display is used to configure boiler settings and monitor boiler operation. The buttons allow changing display mode, entering setting values, and resetting after lockout.

11 Flue pipe adapter (6-inch PVC size, female)

12 Premix gas burner (not shown)

Made with high-grade stainless steel and fiber mesh construction, the burner uses pre-mixed air and gas. The burner and control provide modulating firing.

13 Water outlet pipe (system supply)

14 Water return pipe (system return)

15 Gas connection pipe

16 Manual gas shut-off valve

17 Swing-away control panel assembly

The SlimFit control panel is mounted to a hinged sub panel, allowing the panel to be swung forward and down for easy access to the electrical connections.

18 Air intake adapter (6-inch PVC size, female)

19 Electrical entrances knockouts

Knockouts are provided in the jacket top panel, allowing conduit entry directly behind the control panel or near the wall.

20 Air pressure switch

21 Low water cutoff

22 Heat exchanger flue gas condensate drain

23 Flue gas condensate drain field connection

24 Front door

The front door is sealed to the boiler assembly around its entire perimeter.

25 Jacket door latches

26 Ignition electrode/flame sensor

The burner flame is ignited by applying a high voltage to the ignition electrode. This causes a spark (from electrode to ground). After ignition, the electrode measures flame signal.

Control overview

- The control can operate a single boiler or coordinate with other SlimFit 550/750 Series 3 boilers in a multiple boiler system.
- Control inputs and outputs allow operation of multiple heating circuits (space heating and DHW, for example).
- Up to three priority levels can be set, providing automatic switch-over on demand.
- This manual provides quick set-up information for single boiler installations.
- The Advanced Manual, also supplied with the boiler, provides instructions for setting up multiple-boiler systems and for using advanced options for single boilers.

Control operation

- The control responds to signals from the room thermostats, DHW aquastats (if used), boiler sensors (boiler return, boiler supply, flue temperature), outdoor temperature and system sensor, if used.
- The control automatically adjusts blower speed (and gas flow rate) to match boiler output to space heating and/or DHW heating demand.
- The default control settings provide for three space heating zones. The control can be easily set up for operation with a DHW zone, with or without domestic priority.

Control WIZARD

- The control setup Wizard is available from the BOILER SETTINGS menu that appears during initial startup.
- The Wizard leads through a step-by-step setup procedure designed for the application chosen.
- Context-sensitive help is available to explain the purpose of key setup items.

27 Flame inspection window

The quartz glass window provides a view of the burner surface and flame.

28 Line voltage terminal strip (120 volt power)

29 ON/OFF switch

30 Low gas pressure switch

31 High gas pressure switch

32 Transformer

33 Blower relay

34 Control temperature sensor well

35 P/T gauge pressure sensor tapping

36 P/T gauge temperature sensor well

37 Wire harness connector, line voltage

38 Wire harness connector, low voltage

39 Blower plate

A blower plate is used on SF-550 for both natural gas and propane applications. The SF-750 propane requires a blower plate, but does not use a blower plate on natural gas.

40 Propane gas orifice location

Boilers are shipped with no orifice installed (not required for natural gas). The propane orifice must be installed to operate on propane.

41 Boiler outlet temperature sensor well

42 T/P gauge temperature sensor well

43 Tapping plugged, not used

44 T/P gauge pressure sensor tapping

Located in bottom of supply manifold.

45 Flue inspection plug



The **SlimFit® Series 3** COMMERCIAL gas-fired water boiler

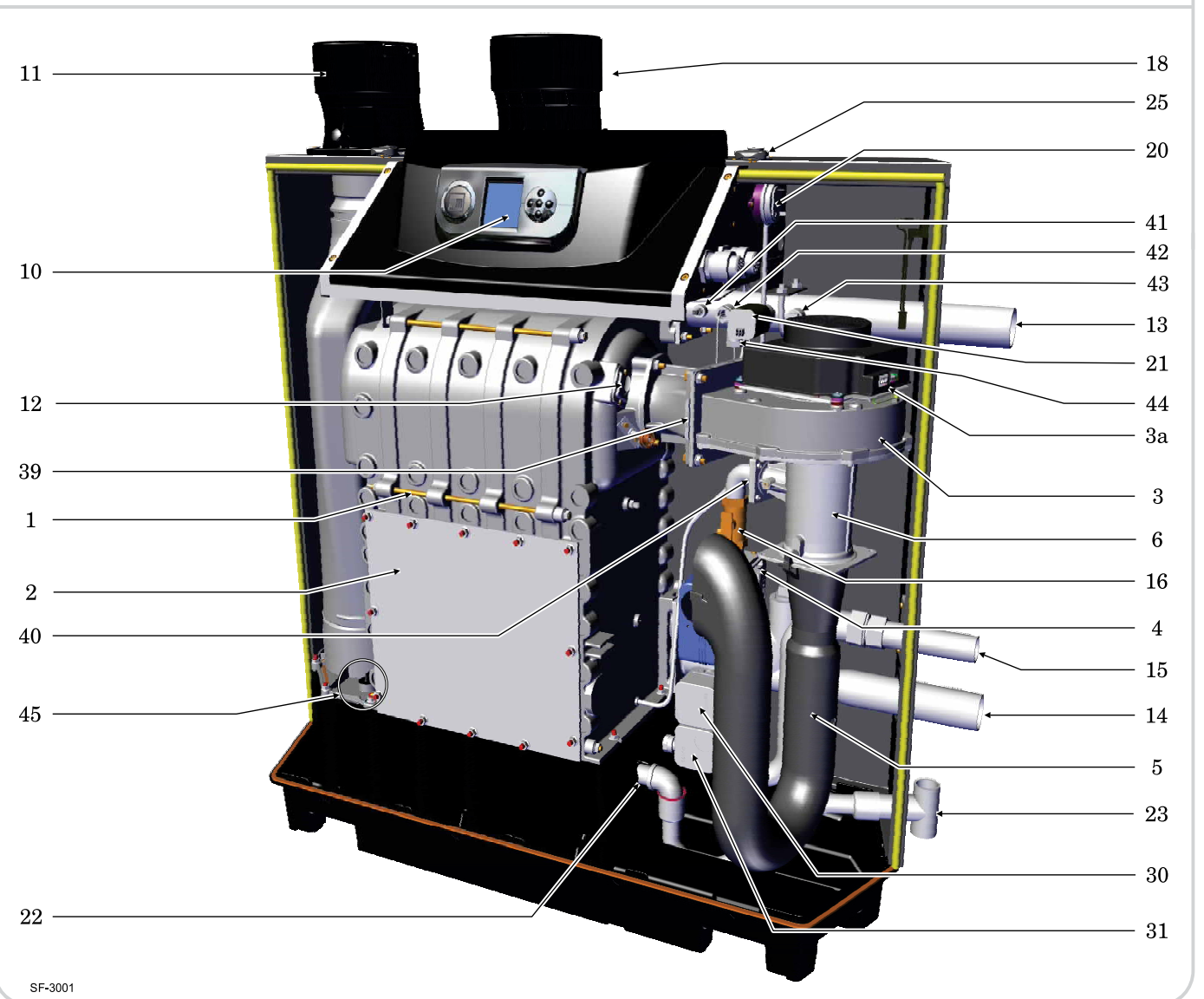
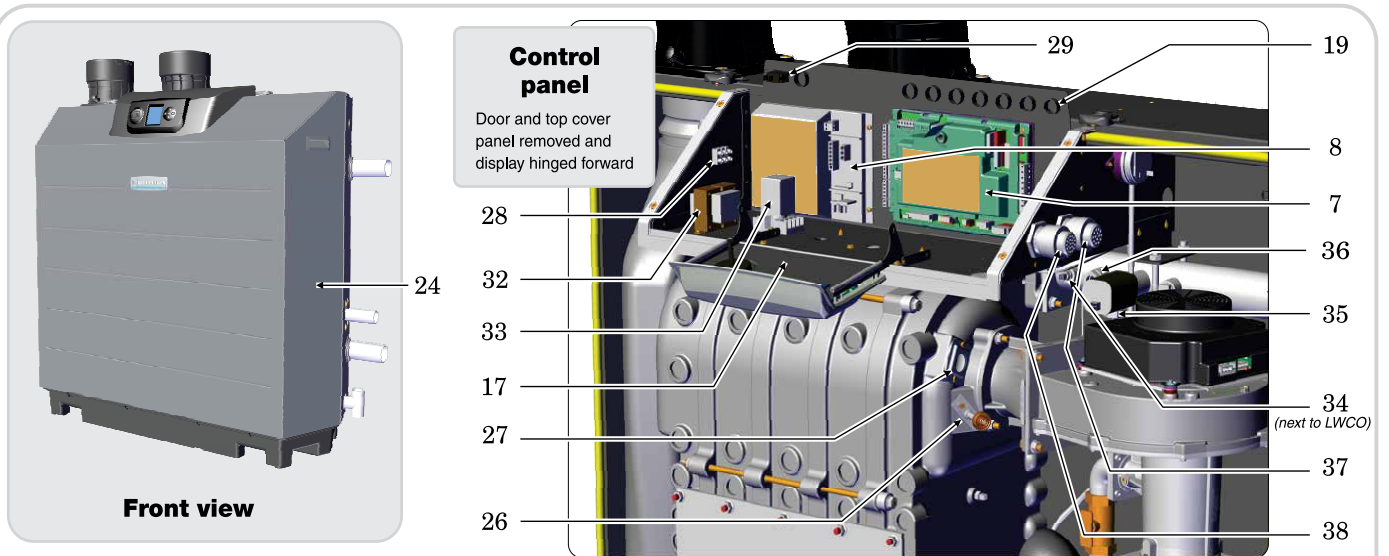

SF-3001



Contents

Contents	4	Field wiring	50
Hazard definitions	4	Wiring Diagrams	60
Please read before proceeding	5	Zoning with the SlimFit Control.	64
Prepare boiler location	6	Control operation and setup	66
Prepare boiler	8	CONTRACTOR menus	72
Install water piping	12	BOILER SETTINGS menu, BASIC mode	73
Venting/air piping — Massachusetts installations	20	PRIORITY 1, 2, 3 menus, BASIC mode	74
Venting/combustion air — general	21	ASSIGN INPUTS menu, BASIC mode	75
Venting/combustion air — options (Category II & IV)	23	DIAGNOSTIC menu	77
Appliances remaining on an existing vent system	23	MAINTENANCE, DATE AND TIME menus	82
Venting/combustion air — options (Category II)	24	Startup — fill the system	83
Direct Exhaust (Category II Only) Venting – general	25	Startup — final checks	85
Direct Exhaust (Category II Only) Boiler room air opening.	26	Operating Instructions	88
Direct Exhaust (Category II Only) – Vertical	27	Check-out/startup verification	89
DIRECT EXHAUST — Boiler room air openings	29	Annual startup and general maintenance.	90
DIRECT EXHAUST — Sidewall	31	Annual startup.	91
DIRECT EXHAUST — Vertical.	34	Troubleshooting	96
DIRECT VENT — Boiler room air openings	36	Maintenance.	105
DIRECT VENT — Sidewall	38	Replacement parts	108
DIRECT VENT — Vertical	42	Dimensions	120
Install vent/air piping — from termination to boiler.	45	Ratings — SlimFit Series 3 boilers	121
Install condensate components.	46	Ratings — multiple SlimFit Series 3 boilers	122
Gas piping	48	Installation and Service Certificate	123
		Installation and Gas Boiler Data Collection Sheet	124

Hazard definitions

The following defined terms are used throughout this manual to bring attention to the presence of hazards of various risk levels or to important information concerning the life of the product.

- ▲ DANGER** Indicates presence of hazards that will cause severe personal injury, death or substantial property damage.
- ▲ WARNING** Indicates presence of hazards that can cause severe personal injury, death or substantial property damage.
- ▲ CAUTION** Indicates presence of hazards that will or can cause minor personal injury or property damage.
- NOTICE** Indicates special instructions on installation, operation or maintenance that are important but not related to personal injury or property damage.



Please read before proceeding

▲WARNING Installer— Read all instructions, including this manual and all other information shipped with the boiler, before installing. Perform steps in the order given.

User — This manual is for use only by a qualified heating installer/service technician. Refer to User's Information Manual for your reference.

User — Have this boiler serviced/inspected by a qualified service technician, at least annually.

Failure to comply with the above could result in severe personal injury, death or substantial property damage.

NOTICE Write in the Consumer Protection (CP) number in the space provided on the Installation certificate on [page 123](#) if not already shown.

When calling or writing about the boiler— Please have the boiler model number from the boiler rating label and the CP number from the boiler jacket.

Consider piping and installation when determining boiler location.

Any claims for damage or shortage in shipment must be filed immediately against the transportation company by the consignee.

▲DANGER If any part of a boiler, burner or its controls has been sprayed with or submerged under water, either partially or fully, **DO NOT attempt to operate the boiler until the boiler has been either replaced or completely repaired, inspected, and you are sure that the boiler and all components are in good condition and fully reliable.** Otherwise, by operating this boiler, you will cause a fire or explosion hazard, and an electrical shock hazard, leading to serious injury, death, or substantial property damage. See the instructions at right.

Saltwater Damage — The exposure of boiler components to saltwater can have both immediate and long-term effects. While the immediate effects of saltwater damage are similar to those of freshwater (shorting out of electrical components, washing out of critical lubricants, etc.), the salt and other contaminants left behind can lead to longer term issues after the water is gone due to the conductive and corrosive nature of the salt residue. Therefore, Weil-McLain equipment contaminated with saltwater or polluted water will no longer be covered under warranty and should be replaced.

Electrical Damage — If any **electrical component or wiring** came into contact with water, or was suspected to have come into contact with water, replace the boiler with a new Weil-McLain boiler.

▲WARNING The installer must verify that at least one carbon monoxide alarm has been installed within a residential living space or home following the alarm manufacturer's instructions and applicable local codes before putting the appliance into operation. Failure to adhere can result in severe personal injury, death, or substantial property damage.

▲WARNING Failure to adhere to the guidelines below can result in severe personal injury, death or substantial property damage.

When servicing boiler —

- To avoid electric shock, disconnect all electrical supplies to the boiler before performing maintenance.
- To avoid severe burns, allow boiler to cool before performing maintenance.
- This boiler contains ceramic fiber and fiberglass materials. Refer to the WARNING and instructions on [page 91](#).

Boiler operation —

- Do not block flow of combustion or ventilation air to boiler.
- Should overheating occur or gas supply fail to shut off, do not turn off or disconnect electrical supply to pump. Instead, shut off the gas supply at a location external to the appliance.

Boiler water —

- The SlimFit heat exchanger is made of aluminum, and requires that system pH always be between 7.0 and 8.5 and water chemistry be checked.
- Chemical treatment is required. See [page 83](#) for details.**

- Thoroughly flush the system** (without boiler connected) to remove sediment. **Install a strainer or other sediment removal equipment** if necessary. The high-efficiency heat exchanger can be damaged by build-up or corrosion due to sediment.
- Do not use petroleum-based cleaning or sealing compounds in boiler system. Gaskets and seals in the system may be damaged. This can result in substantial property damage.
- Continual fresh make-up water will reduce boiler life. Mineral buildup in heat exchanger reduces heat transfer, overheats the aluminum heat exchanger, and causes failure. Addition of oxygen carried in by make-up water can cause internal corrosion. Leaks in boiler or piping must be repaired at once to prevent make-up water. Use this boiler **ONLY** in a closed-loop system.
- Do not add cold water to a hot boiler. Thermal shock can cause heat exchanger to crack.

Freeze protection fluids —

NEVER use automotive or standard glycol antifreeze, even glycol made for hydronic systems. Use only freeze-protection fluids recommended in this manual (see [page 83](#)). Follow all guidelines given. Thoroughly clean and flush any replacement boiler system that has used glycol before installing the new SlimFit boiler.

▲CAUTION Frozen Water Damage Hazard

- Residences or buildings that are unattended in severely cold weather, boiler system components failures, power outages, or other electrical system failures could result in frozen plumbing and water damage in a matter of hours. For your protection, take preventative actions such as having a security system installed that operates during power outages, senses low temperature, and initiates an effective action. Consult with your boiler contractor or a home security agency.

Commonwealth of Massachusetts

When the boiler is installed within the Commonwealth of Massachusetts:

- This product must be installed by a licensed plumber or gas fitter.
- If antifreeze is used, a reduced pressure back-flow preventer device shall be used.
- Sidewall vent air installations — see instruction on [page 20](#).



Prepare boiler location

Installations must comply with:

- Local, state, provincial, and national codes, laws, regulations and ordinances.
- National Fuel Gas Code, ANSI Z223.1/NFPA 54 – latest edition.
- Standard for Controls and Safety Devices for Automatically Fired Boilers, ANSI/ASME CSD-1, when required.
- National Electrical Code, ANSI/NFPA 70 – latest edition.
- For Canada only: B149.1 or B149.2 Installation Code, CSA C22.1 Canadian Electrical Code Part 1 and any local codes.

NOTICE The SlimFit boiler gas manifold and controls met safe lighting and other performance criteria when boiler underwent tests specified in ANSI Z21.13 — latest edition.

Before locating the boiler, check:

1. Check for nearby connection to:
 - System water piping
 - Venting connections
 - Gas supply piping
 - Electrical power
 - Location of drain for condensate
2. Check area around boiler. Remove any combustible materials, gasoline and other flammable liquids.

WARNING Failure to keep boiler area clear and free of combustible materials, gasoline and other flammable liquids and vapors can result in severe personal injury, death or substantial property damage.

3. The SlimFit boiler must be installed so that gas control system components are protected from dripping or spraying water or rain during operation or service.
4. If new boiler will replace existing boiler, check for and correct system problems, such as:
 - System leaks causing oxygen corrosion or heat exchanger cracks from hard water deposits.
 - Incorrectly-sized expansion tank.
 - Lack of freeze protection in boiler water causing system and boiler to freeze and leak.

Provide clearances:

Clearances from combustible materials

1. Hot water pipes — at least 1/2" from combustible materials.
2. Vent pipe — at least 3/16" from combustible materials.
3. See Figure 1 for other clearance minimums.

Clearances for service access

See Figure 1 for recommended service clearances. If you do not provide minimum clearances shown, it might not be possible to service the boiler without removing it from the space.

Figure 1 Clearances

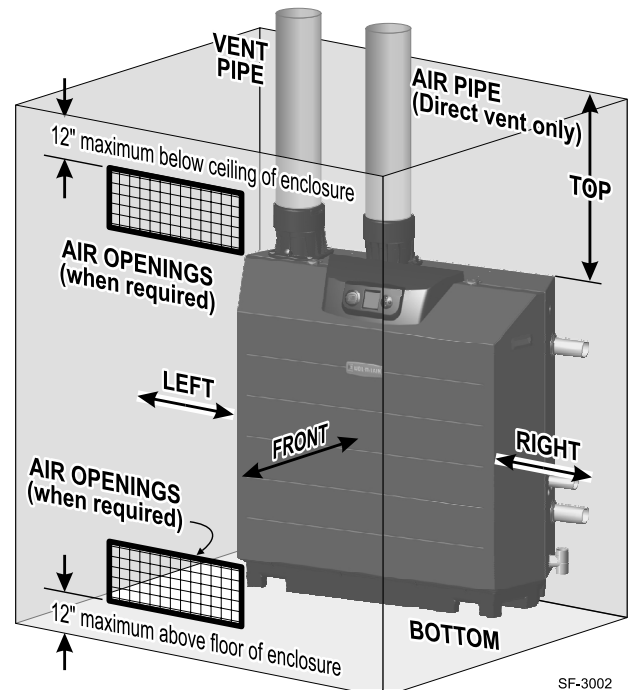

Clearance from	Minimum clearance to combustible surfaces (inches)	Recommended service access clearances (inches)
LEFT	0	0
RIGHT	0	12
TOP	20	20
BOTTOM (Floor)	0	0
FRONT	1/2	24
BACK	0	0
VENT PIPE	3/16 **	NA
HOT WATER PIPES	1/2	NA

** Openings in combustible floors, walls, ceilings or roofs must be 3/8" larger in diameter than the vent pipe and must be lined with steel thimbles and designed for fire stopping as required by applicable codes.

WARNING Provide air openings for combustion air and/or ventilation of the room as specified in this manual and as required by applicable codes.



Prepare boiler location *(continued)*

Flooring and foundation

Flooring

The SlimFit boiler is approved for installation on combustible flooring, but must never be installed on carpeting.

▲WARNING Do not install boiler on carpeting even if foundation is used. Fire can result, causing severe personal injury, death or substantial property damage.

Foundation

1. The boiler mounting surface must be level and suitable for the load.
2. Provide a solid foundation pad, at least 2 inches above the floor, if any of the following is true:
 - floor can become flooded.
 - the floor is dirt, sand, gravel or other loose material.
 - the boiler mounting area is severely uneven or sloped.
3. The minimum foundation size is:
 - 48 inches wide x 20 inches deep.
4. Foundation may be of wood, brick or concrete (minimum 2 inches thick) construction.
5. If flooding is possible, elevate boiler sufficiently to prevent water from reaching boiler.

Garage installation

Precautions

Take the following special precautions when installing the boiler in a garage. If the boiler is located in a garage:

- Mount the boiler at a height above the floor as specified in the National Fuel Gas Code, ANSI Z223.1/NFPA 54 for U. S. installations, or CSA B149.1 and B149.2 for Canadian installations.
- Locate or protect the boiler so it cannot be damaged by a moving vehicle.
- Ensure that the installation complies with all applicable codes.

Provide air openings to room

Air openings — General

Follow the National Fuel Gas Code (U. S.) or CSA B149.1 and B149.2 (Canada) and all applicable codes to size/verify size of the combustion/ventilation air openings into the space. See the venting instructions section of this manual for required air openings and sizing for either direct vent or direct exhaust installation.

Air openings — SlimFit boiler alone in boiler room

1. **DIRECT VENT** — For direct vent installations (air piped to boiler), no air ventilation openings into boiler room are needed if clearances around the SlimFit boiler are at least equal to the SERVICE clearances shown in [Figure 1, page 6](#). For spaces that DO NOT supply the minimum service access clearances, see the direct vent venting instructions in this manual for required openings.

2. **DIRECT EXHAUST** — For direct exhaust installations (combustion air from inside), provide air openings as specified in the direct exhaust venting section of this manual.

Air openings — SlimFit boiler in same room with other gas or oil-fired appliances

1. **DIRECT VENT** — For direct vent installations (combustion air piped to boiler), size openings only on the basis of the other appliances in the space. No additional air opening free area is needed for the SlimFit boiler because it takes its combustion air from outside.

▲WARNING For direct vent installations, when the SlimFit boiler is located in the same room as other appliances, provide combustion air openings correctly sized for all appliances in the room except the SlimFit boiler.

Reinstall the boiler jacket front door after servicing. The boiler front door must be securely fastened to the boiler to prevent the boiler from drawing air from inside the boiler room. This is particularly important if the boiler is located in the same room as other appliances.

Failure to comply with the above warnings could result in severe personal injury, death or substantial property damage.

2. **DIRECT EXHAUST** — For direct exhaust installations, combustion air openings into the room must be sized to handle the SlimFit boiler and all other appliances. See the direct exhaust venting instructions in this manual for required openings.

▲WARNING For direct exhaust installations, when the SlimFit boiler is located in the same room as other appliances, provide combustion air openings correctly sized for all appliances, including the SlimFit boiler.

Failure to comply with the above warnings could result in severe personal injury, death or substantial property damage.



Prepare boiler

Vent and air piping requirements (page 20)

- The SlimFit boiler requires a special vent system, designed for pressurized venting.
 - SlimFit boilers are rated ANSI Z21.13 Category IV (pressurized vent, likely to condense in the vent).
 - SlimFit commercial boilers can be either **direct-exhaust** (vent to the outside, combustion air from inside) or **direct-vent** (vent and air piped outside).
 - See instructions beginning on [page 20](#) for vent/air configuration options and installation requirements.
- Note “Prevention of combustion air contamination” on [page 22](#) when considering vent/air terminations and boiler room conditions when using inside air (direct exhaust installation).
- Be sure to locate the boiler such that the vent and air piping can be routed through the building and properly terminated. The vent/air piping lengths, routing and termination method must all comply with the methods and limits in instructions beginning on [page 21](#).

Remove boiler from crate

CAUTION Cold weather handling — If boiler has been stored in a very cold location (below 0°F) before installation, handle with care until the plastic components come to room temperature.

WARNING Do not lift or handle the boiler by the water or gas pipes.

- Leave boiler on crate base until ready to place in final location.
- Cut the retaining straps. Make sure the boiler is sitting securely.
- Remove outer shipping carton from boiler.

CAUTION Leave the plastic cover on the boiler vent outlet until ready to attach vent piping. This will prevent debris from falling into the vent adapter.

Flue cover

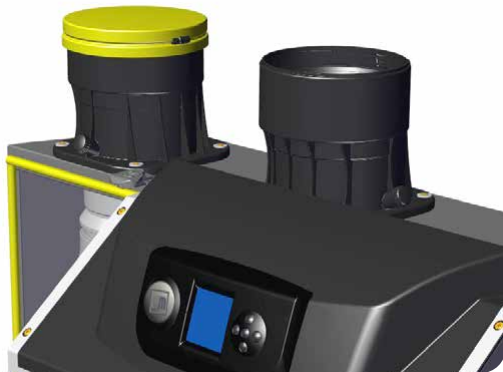

- After removing the packaging, lift boiler from the skid and place in position.

NOTICE Do not drop the boiler. Damage to boiler components can result.

WARNING **Inspect the boiler base for cracks or possible damage in handling.** The base must be in good condition and sealed tightly for proper operation of the boiler.

Placing the boiler

Set the boiler in place and check level. Use shims if necessary to level the boiler (and condensate pump, if used).

Prepare boiler for propane (when required)

WARNING SlimFit boilers must be converted for propane operation — all boilers are shipped ready for natural gas operation, and must be fitted with a propane orifice to be used on propane. Model 750 boilers also require installation of a propane blower orifice, supplied in the propane conversion kit.

High altitude installations

No orifice change is required for high-altitude installations. The Control automatically adjusts boiler operation for altitude when set properly. Select “YES” in the Control setup for the **High Altitude** option (see [Figure 62, page 73](#)).

Verify orifice size

See [Figure 2, page 10](#). Verify when installing the propane orifice that the orifice size marking matches boiler size.

Model 750 boilers also require installation of a blower orifice for propane operation. The orifice is supplied in the propane conversion kit.

Converting existing natural gas-fired boiler for propane

For a boiler already installed, you must turn off gas supply, turn off power and allow boiler to cool before proceeding.

Verify operation after conversion

You must completely test the boiler after conversion to verify performance. Start up the boiler following instructions in this manual.

Failure to comply with the above could result in severe personal injury, death or substantial property damage.

Install propane orifice — SF-550 or -750

WARNING **If boiler is already installed** — You must turn off electrical supply to the boiler and close the external manual gas shut-off valve to isolate the boiler during conversion. Allow the boiler to cool if it has been operating. Following conversion of an installed boiler, follow all instructions in this manual to start up the boiler and verify operation of the boiler and all system components.

WARNING SF-550 boilers are shipped with a blower plate that is used for natural gas and propane. The blower plate must be left in place for propane applications.



Prepare boiler *(continued)*

1. Locate propane orifice disc from conversion kit bag shipped with the boiler.
2. Verify that the stamping on the orifice disk matches the model size (see [Figure 2, page 10](#)).
3. Remove front door by rotating the two rotary latches.
4. Lift the door away from boiler.
5. See [Figure 2, page 10](#).
6. Disconnect the gas train adapter flange (see item 12) from the venturi gas line flange (see item 7):
 - a. Use a 4 mm Allen wrench and 8 mm open-end or box wrench to loosen the four (4) screws and nuts (items 10 and 11).
 - b. Remove the gasket (item 9).
16. Secure the flanges together with the bolts and nuts, being careful not to over-tighten (torque to 15 N-m/132 in-lbs/11 ft-lbs).
17. Reconnect the two (2) blower wiring harnesses.
18. Reinstall front door, and secure the latches.
19. Restore electrical power, turn on gas by opening manual gas valve and check for leaks.
20. Follow instructions starting on [page 86](#) to adjust combustion values for propane gas.
21. Perform a complete start up sequence, starting on [page 83](#), including a check for gas leaks and confirming proper performance.
22. After placing the boiler in operation, the ignition system safety shutoff device must be tested, [page 87](#).

- ▲WARNING** Inspect the gasket between the gas train adapter flange (see item 12) and the venturi gas line flange (see item 7). The gasket must be in good condition and must be installed. Failure to comply could result in a gas leak, resulting in severe personal injury, death or substantial property damage.
- c. The gas train is connected with a flexible gas line. Pull the gas train forward and support it temporarily.
 - d. Insert the propane orifice into the counterbore in the venturi flange.
 - e. Reposition the gasket and gas train adapter against the venturi gas line flange.
 - f. Secure with the four (4) screws and nuts. Do not over-tighten, but make sure the joint is secure (torque to 1.5 N-m/13 in-lbs/1 ft-lb).

SF-750 propane only — Install the propane blower plate and gaskets

1. See [Figure 2, page 10](#).
2. Disconnect the two wire harnesses connected to the blower.
3. SF-750 natural gas boilers do not use a blower plate. The boiler is shipped with a blower plate and gaskets that must be installed to operate the boiler on propane.
4. Obtain the two (2) gaskets (item 3) and blower plate (item 4) shipped with the boiler.
5. Check the blower plate to ensure it says “750 LP.”
6. Turn off all power sources to the boiler.
7. Disconnect the two (2) wiring connectors on the blower.
8. Disconnect the blower flange (see item 6) from the mixing tube flange (see item 5) as shown.
9. Use a 13 mm nut driver or ratchet for the screws and a 13 mm open-end wrench for the nuts.
10. Support the weight of the blower and gas train temporarily.
11. Insert the top two (2) bolts through the mixing tube flange.
12. Slide on the two (2) gaskets and blower plate, with one gasket on each side as shown.
13. Position the blower.
14. Align all parts and start the nuts on the top two (2) bolts.
15. Insert the remaining two (2) bolts and fasten with nuts. Be careful not to tear the gasket.

Legend for [Figure 2, page 10](#)

(see [Figure 98, page 116](#) for part numbers)

1. Hex bolts (4), M8 x 30 mm — requires 13 mm open-end wrench, box wrench or ratchet.
2. Hex nuts (4), M8 keps — nylon lock nuts — requires 13 mm open-end wrench, box wrench or ratchet.
3. Blower plate gasket (one on each side of blower plate). One gasket is used on SF-750 natural gas, because this unit does not use a blower plate — blower plate is only used for the SF-750 propane. SF-550 boilers use a plate for natural gas and propane (same plate is used for both fuels).
4. Blower plate — used on all SF-550, natural gas and propane; used on SF-750 propane only (not on SF-750 natural gas).
5. Mixing tube.
6. Blower motor and blower.
7. Venturi — with gas line flange and inlet air connection.
8. Propane orifice — shipped with boiler — verify the model number stamped on the orifice.
9. Gasket — venturi gas flange to gas line adapter flange.
10. Hex nuts (4), M5 keps — requires 8 mm open-end or box wrench.
11. Hex bolts (4), M 5 x 20 mm — requires 4 mm Allen wrench.
12. Gas line adapter flange.
13. Manual gas valve.
14. Automatic gas valve.



Prepare boiler *(continued)*

See page 9 for legend

Figure 2 A blower plate is used on all SF-550 boilers, for both natural gas and propane.
 A blower plate is used on SF-750 propane, but NOT on natural gas.
 A propane orifice MUST be installed on both the SF-550 and SF-750 to operate on propane.

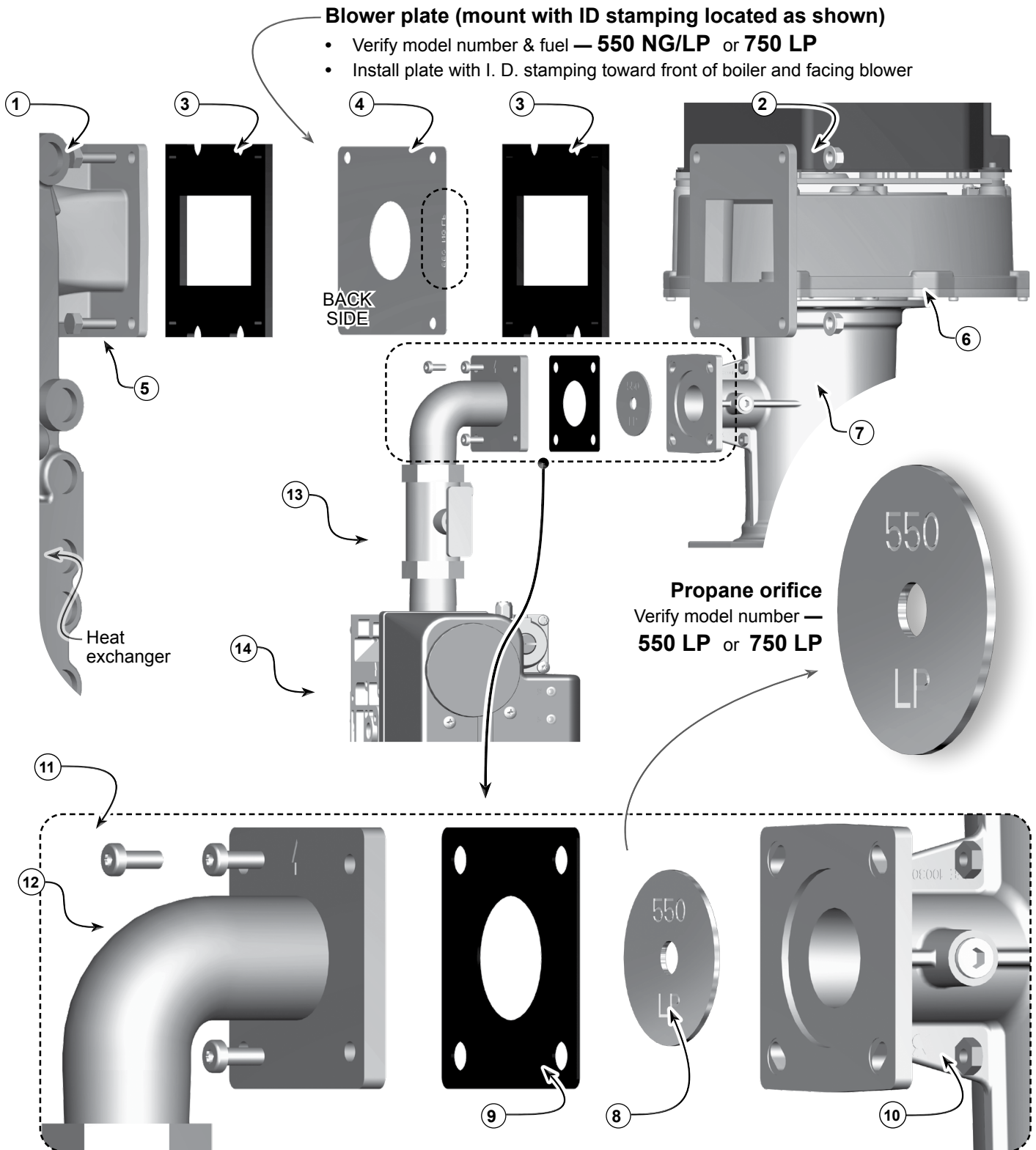

Prepare boiler *(continued)*

⚠WARNING DO NOT install a relief valve with a pressure higher than 80 PSIG. This is the maximum allowable relief valve setting for the SlimFit boiler. The boiler is shipped with a 30 PSIG relief valve. See [Replacement parts](#), starting on page 108 for alternate pressure setting relief valves.

Perform hydrostatic pressure test

Pressure test boiler before permanently attaching water or gas piping or electrical supply.

Prepare boiler for test

1. See Figure 3 for reference in following steps. Use pipe dope sparingly.
2. Remove 2" supply line tee, 2x $\frac{3}{4}$ " bushing and $\frac{3}{4}$ " nipple from accessory bag.
3. Pipe 2" tee, bushing and $\frac{3}{4}$ " nipple to boiler supply connection as shown.
4. Temporarily plug the end of the 2" supply tee.
5. Attach a $\frac{3}{4}$ " shut-off valve (by others) to the $\frac{3}{4}$ " nipple.
6. Attach a 2-inch tee (by others) to the boiler return pipe.
7. Install a bushing and a $\frac{3}{4}$ -inch boiler drain valve off of the tee as shown. Temporarily plug the end of the tee. (All fittings by others.)
8. Connect a hose to the boiler drain valve, with the other end connected to a fresh water supply. Make sure the hose can also be used to drain the boiler after test.
9. To avoid getting water on the boiler, you may want to pipe street elbows on top of shutoff valves and attach catch-buckets beneath.
10. If convenient, install any other piping compatible with Figure 3 that would still allow bleeding air from shutoff valves.

Fill and pressure test

1. Open the shutoff valves you installed on supply and return connections.
2. Slowly open boiler drain valve and fresh water supply to fill boiler with water. The boiler will fill quickly because of its low water content.
3. When water reaches the shutoff valve on top, allow water to flow long enough to ensure all air is out of the heat exchanger. Then close the boiler drain valve.
4. Close shutoff valve on top.
5. Increase test pressure until the pressure/temperature gauge reaches 120 psig, but no higher. DO NOT exceed 120 psig.
6. Hold at test pressure for 10 minutes.

⚠WARNING Do not leave boiler unattended. A cold water fill could expand and cause excessive pressure, resulting in severe personal injury, death or substantial property damage.

7. Make sure constant gauge pressure has been maintained throughout test. Check for leaks. Repair if found.

Figure 3 Hydrostatic test piping connections

Attach the 2x2-inch tee supplied with the boiler to the boiler supply pipe. Insert the 2x $\frac{3}{4}$ -inch bushing (supplied with the boiler) and $\frac{3}{4}$ -inch nipple (supplied with the boiler) into the branch side of the tee. Attach a temporary $\frac{3}{4}$ -inch shut-off valve (by others) to the nipple and temporarily plug the end of the 2-inch tee.

After testing, remove the temporary $\frac{3}{4}$ -inch shut-off valve. Replace with the relief valve. Remove the plug (by others) in the supply end of the 2-inch tee.

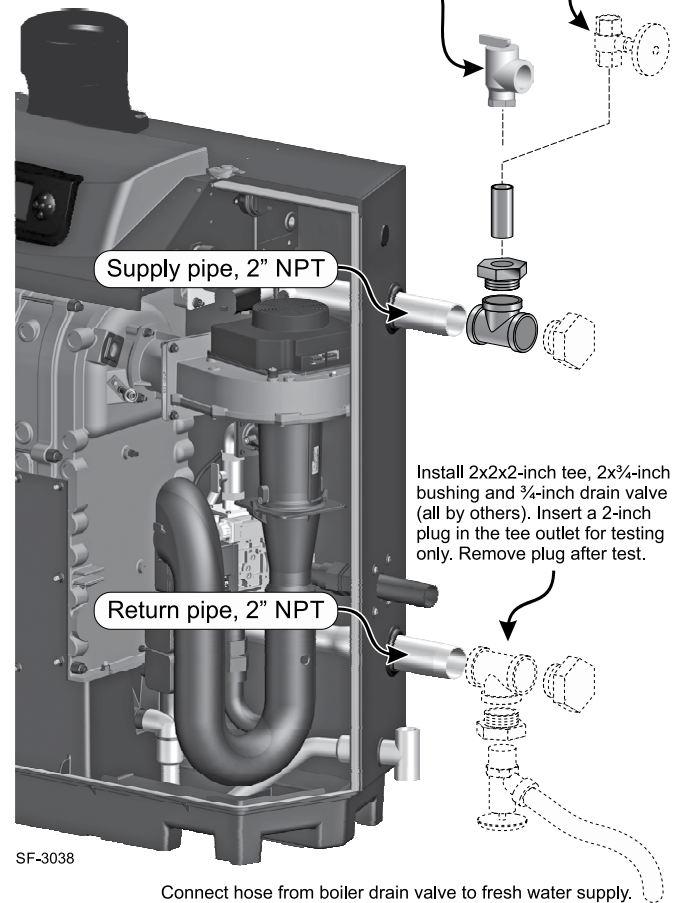

SF-3038

Connect hose from boiler drain valve to fresh water supply.

⚠WARNING Leaks must be repaired at once. Failure to do so can damage boiler, resulting in substantial property damage.

⚠WARNING Do not use petroleum-based cleaning or sealing compounds in boiler system. Gaskets and seals in the system may be damaged. This can result in substantial property damage.

Drain and remove fittings

1. Disconnect fill water hose from water source.
2. Drain boiler through drain valve. Remove hose after draining.
3. Remove pipe fittings unless they will remain for use in the system piping.
4. Remove the $\frac{3}{4}$ " shut-off valve from the $\frac{3}{4}$ " relief valve nipple.
5. See [page 12](#) to install relief valve (female) on the $\frac{3}{4}$ " nipple.



Install water piping

▲WARNING Use two wrenches when tightening water piping at boiler, using one of the wrenches to prevent the boiler interior piping from turning. Failure to support the boiler piping connections to prevent them from turning could cause damage to boiler components.

General piping information

Additional controls, when required

NOTICE The Control module uses temperature sensors to provide both high limit protection and modulating temperature control, and is UL353 Limit Controls certified to meet ASME CSD-1 and Section IV requirements. The Control module also provides low water protection, both with a low water cut-off inside the boiler jacket and by sensing the temperature of the heat exchanger. Some codes/jurisdictions may require additional external controls.

Additional limit controls

1. Consult local requirements for other codes/standards to determine if additional limit devices are needed.

▲WARNING **Multi-temperature systems** — If the heating system includes circuits that require lower temperature water (radiant slab circuits, for example) as well as higher temperature circuits, it is recommended to protect low-temperature circuits with limit controls that are wired to a Control external limit circuit (P13 terminals 1 and 2 for manual reset, or P13 terminals 3 and 4 for automatic reset).

2. See instructions beginning on [page 50](#) for wiring information.
 - a. Manual reset operation: If external limit controls are to cause **manual reset** of the Control module, connect series-wired isolated contacts to P13 terminals 1 and 2 (see [page 50](#) for wiring information).
 - b. Automatic reset operation: If external limit controls are to cause **automatic reset** of the Control module, connect series-wired isolated contacts to P13 terminals 3 and 4 (see [page 50](#) for wiring information).

Low water cutoff

1. A push-to-test low water cutoff is included with the boiler. The low water cutoff is mounted on the boiler supply manifold, and is available for test by removing the boiler jacket.
2. Operation of the low water cutoff is manual reset through the Control.

Backflow preventer

Use backflow check valve in cold water supply as required by local codes.

Install relief valve

1. Install relief valve (female) on the 3/4" nipple in the 2x3/4" bushing on the boiler supply piping tee ([Figure 3, page 11](#)). The relief valve must be piped with no smaller than 3/4" pipe and fittings.
2. Connect discharge piping to safe disposal location, following guidelines in the **WARNING** below.

▲WARNING **To avoid water damage or scalding due to relief valve operation, as per local or state codes:**

Discharge line must be connected to relief valve outlet and run to a safe place of disposal. Terminate the discharge line in a manner that will prevent possibility of severe burns or property damage should the valve discharge.

Discharge line must be as short as possible and be the same size as the valve discharge connection throughout its entire length.

Discharge line must pitch downward from the valve and terminate at least 6" above the floor drain where any discharge will be clearly visible.

The discharge line shall terminate plain, not threaded, with a material serviceable for temperatures of 375 °F or greater.

Do not pipe the discharge to any place where freezing could occur.

No shutoff valve shall be installed between the relief valve and boiler, or in the discharge line. Do not plug or place any obstruction in the discharge line.

Test the operation of the valve after filling and pressurizing system by lifting the lever. Make sure the valve discharges freely. If the valve fails to operate correctly, replace it with a new relief valve.

Failure to comply with the above guidelines could result in failure of the relief valve to operate, resulting in the possibility of severe personal injury, death or substantial property damage.



Install water piping *(continued)*

System water piping methods

NOTICE All piping methods shown in this manual use **primary/secondary connection to the boiler loop**. These designs ensure proper flow through the SlimFit boiler, for the most efficient and reliable operation of the boiler and the heating system. For other piping methods, consult your local WM Technologies representative or see separate SlimFit boiler piping guides.

Recommended pipe sizing

Connect minimum pipe sizing shown in Figure 4 to the supply and return connections for SF-550 and SF-750 boilers.

Figure 4 Suggested pipe sizing for boiler loop

Model	Boiler loop
SF-550	2" or larger
SF-750	2" or larger

Size the piping and the boiler circulator to provide the required temperature rise through the boiler loop. See Figure 5 for the head loss through the boiler and minimum/maximum flow rates.

CAUTION **DO NOT** design the piping and components for a boiler loop flow rate above or below the range given in Figure 4. Insufficient flow will cause nuisance outages due to limit operation. Excessive flow can damage to the boiler heat exchanger from erosion.

Circulators

The boiler circulator must be supplied by others. Locate the boiler circulator in the return piping, as shown in the appropriate piping diagram in this manual.

WARNING **DO NOT** use the boiler circulator in any location other than the ones shown in this manual. The boiler circulator must be selected to ensure adequate flow through the SlimFit boiler.

Install the boiler circulator only on the boiler return piping. This ensures the pressure drop through the boiler will not cause low pressure in the circulator intake.

Failure to comply could result in unreliable performance and nuisance shutdowns from insufficient flow.

A Taco model 1400-50 or equivalent will work for most boiler loop circulator applications.

Figure 5 Boiler head loss vs flow rate for SF-550 & SF-750

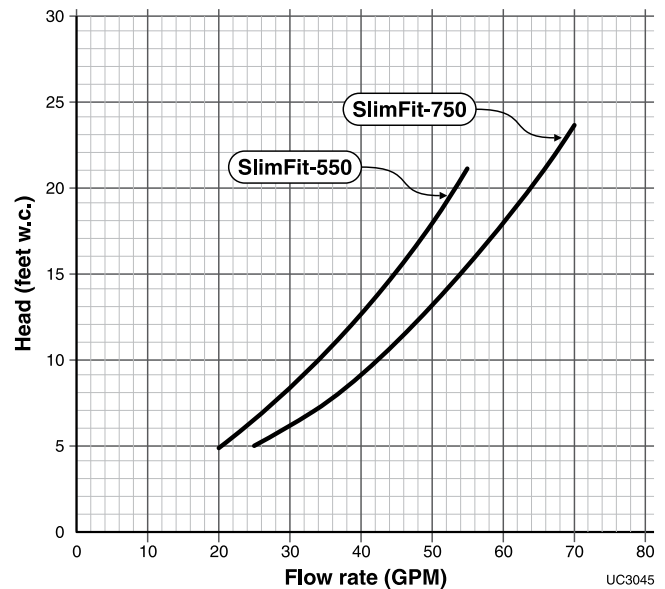

SF-550			SF-750		
GPM	Temp. Rise °F	Boiler head loss Feet w.c.	GPM	Temp. Rise °F	Boiler head loss Feet w.c.
25	41.0	6.3	30	46.4	6.3
30	34.1	8.1	35	39.8	7.6
35 *	29.3	10.2	40	34.8	9.2
40	25.6	12.5	45 *	30.9	11.0
45	22.8	15.1	50	27.8	13.0
50	20.5	18.1	55	25.3	15.3
55	18.6	21.3	60	23.2	17.9
DO NOT design for flow rates above or below the range listed above.			65	21.4	20.7
			70	19.9	23.6
			DO NOT design for flow rates above or below the range listed above.		
* Suggested design flow rates (30°F temperature rise).					

NOTICE The Slimfit 550/750 control will reduce the firing rate when the temperature rise exceeds 45°F, at 58°F the control will turn off the boiler. For modulating pumps a minimum allowable flow for a Slimfit 550 is 4 GPM and the Slimfit 750 is 5 GPM, but the variable speed pump must be controlled to increase flow rate between minimum and full rate.



Install water piping *(continued)*

Expansion tank and make-up water

1. Ensure expansion tank size will handle boiler and system water volume and temperature. Allow 7 gallons per boiler for the boiler and its piping.

CAUTION Undersized expansion tanks cause system water to be lost from relief valve and make-up water to be added through fill valve. Eventual boiler failure can result due to excessive make-up water addition.

2. Tank must be located as shown in this manual, or following recognized design methods. See tank manufacturer's instructions for details.
3. Connect the expansion tank to the air separator only if the separator is on the suction side of the circulator. Always install the system fill connection at the same point as the expansion tank connection to the system.
4. Most piping drawings in this manual show diaphragm expansion tanks. See Figure 6 for piping from air separator to expansion tank and make-up water line using a closed-type expansion tank.
5. Most chilled water systems are piped using a closed-type tank, as shown in [Figure 11, page 19](#).

Diaphragm (or bladder) expansion tank

(Figure 6) Always install an automatic air vent on top of the air separator to remove residual air from the system.

NOTICE When using diaphragm or bladder tanks only — when the boiler is installed above the system main piping, install an automatic air vent in the top of the outgoing boiler piping to prevent air pocketing.

Closed-type expansion tank

1. See Figure 6, Alternate, for piping connections when using a closed-type expansion tank.
2. Pitch any horizontal piping up towards tank 1 inch per 5 feet of piping. Connect to tank with at least 3/4" piping to allow room for air to rise.

CAUTION DO NOT install automatic air vents on closed-type expansion tank systems. Air must remain in the system and return to the tank to provide its air cushion. An automatic air vent would cause air to leave system, resulting in water-logging the expansion tank.

NOTICE Install a union on the boiler supply and return connections as close as possible to the boiler to allow disconnection for service when required. See Figure 6.

Figure 6 Expansion tank piping

Piping to diaphragm (or bladder) expansion tank

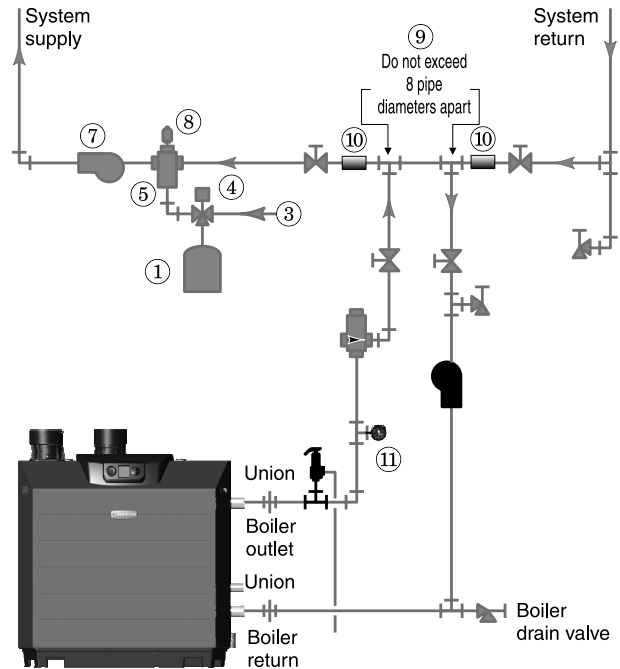

Alternate — Piping to closed-type expansion tank

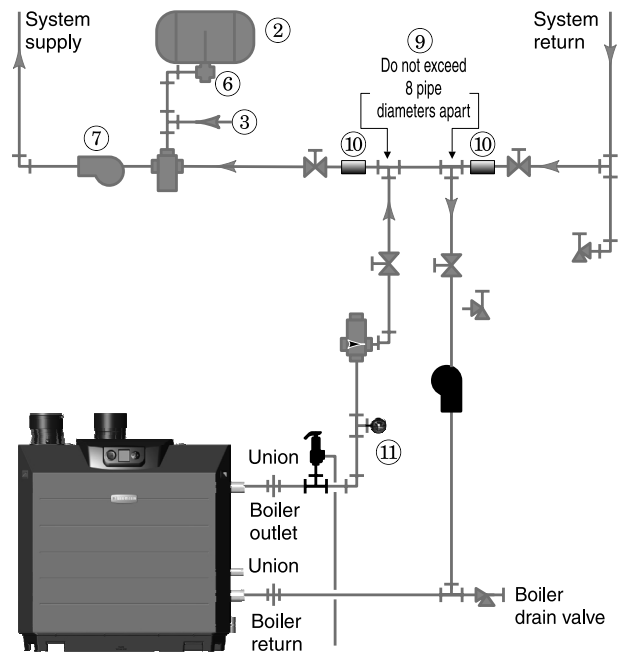

- | | |
|---------------------------------|--|
| ① Diaphragm-type expansion tank | ⑥ Tank fitting |
| ② Closed-type expansion tank | ⑦ System circulator |
| ③ Make-up water supply | ⑧ Automatic air vent |
| ④ Fill valve, typical | ⑨ Primary/secondary connection |
| ⑤ Air separator | ⑩ System supply/return sensors |
| | ⑪ Pressure temperature gage mounted on boiler outlet |

SF-3039



Install water piping *(continued)*

ZONE VALVE zoning – primary/secondary (Shown with optional DHW piping) See Figure 7.

This configuration is for zone valve systems using a boiler loop connected as a secondary circuit off of a primary system loop. The primary/secondary piping shown ensures the boiler loop will have sufficient flow. It also avoids applying the high head of the boiler circulator to the zone valves.

1. Install a system circulator (supplied by installer) capable of delivering the proper flow and head as shown.
2. The flow/check valve shown on the boiler outlet piping prevents gravity circulation in the boiler loop during DHW heating.

CAUTION Use **at least** the **MINIMUM** pipe size shown in Figure 4, page 13 on all boiler loop piping (connecting boiler to and from the primary/secondary connection, item 21). **Primary/secondary piping shown** ensures the boiler loop will have sufficient flow. For other piping methods, see guides on page 13.

Expansion Tank required

1. Provide a system expansion tank following the guidelines on page 14.
2. **DO NOT** use a closed-type tank if connecting to a water heater that is equipped with an automatic vent.

Domestic Hot Water (DHW) tank, if used

1. DHW direct connection—Pipe from the near-boiler piping to the DHW tank's boiler connections as shown.
2. DHW as zone—A DHW tank can be connected as a zone if a DHW tank is **NOT** already connected to the boiler. See Advanced Manual to configure Boiler Pump to run during DHW demands and change TARGET MOD SENSOR to System Supply.
3. Priority of DHW/Space Heating:
 - a. DHW Priority – DHW is priority over space heating. Use Priority 1 for DHW; Priorities 2 and/or 3 for space heating. The control will not run multiple priorities simultaneously.
 - b. Space Heating Priority – Space heating is priority over DHW. Use Priorities 1 and/or 2 for space heating; Priority 3 for DHW. The control will not run multiple priorities simultaneously.
 - c. No Priorities – Space heating and DHW can occur simultaneously. Use only if DHW is a zone in system. Assign DHW and Space heating to same Priority. Do not use outdoor reset for this application.

Controlling the circulators

1. The control can control up to four circulators (boiler circulator and three others). Refer to Field wiring, beginning on page 50, for instructions on wiring to circulators.
2. The factory default settings are: all three inputs are set up for Space Heating (Priority 2). Each input correlates to its respective circulator

Figure 7 Zone valve zoning plus optional DHW piping

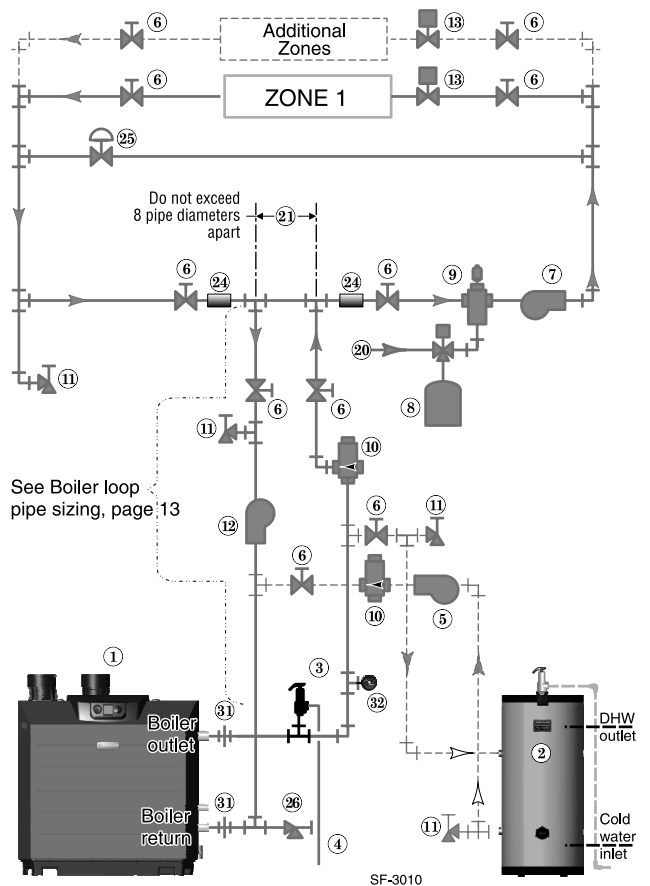

output. For DHW applications, assign DHW inputs to determined Priority (1, 2 or 3). Priority 1 is defaulted to DHW for DHW Priority applications.

3. For more than 3-zones, use Weil-McLain WMZV zone valve controller.

NOTICE Connect zone valve end switches to a Space Heating Priority input, (default Priority 2) to use default settings. Connect system circulator to corresponding output.

CAUTION Use isolation relays if connecting 3-wire zone valve end switches to the inputs.

Legend — Figure 7

1 SlimFit boiler	12 Boiler circulator
2 Indirect water heater (DHW), if used	13 Zone valves, typical
3 Boiler relief valve (see page 12 for piping details)	20 Make-up water supply
4 Relief valve discharge piping (see page 12 for details)	21 Primary/secondary connection
5 DHW circulator	24 Strap system supply and return sensors to lines as shown, at least 6 pipe diameters (but no more than 3 feet) from boiler connection tees.
6 Isolation valves	25 Systems using high-head pumps may require a bypass pressure regulator to prevent damage to control valves.
7 System circulator (see information above for wiring)	26 Boiler drain valve, ¼" or larger
8 Diaphragm (or bladder) type expansion tank (see page 14 for piping of closed-type expansion tank, if used)	31 Install a union on the boiler supply and return connections as close as possible to the boiler to allow disconnection for service when required.
9 Air separator [with automatic air vent only on systems using diaphragm (or bladder) type expansion tank]	32 Pressure/Temperature gauge mounted on boiler outlet.
10 Flow/check valves	■ Items supplied with boiler
11 Purge/drain valves	■ Items supplied by others



Install water piping *(continued)*

Zoning with zone valves — alternate High-flow-rate/high-head-loss DHW circuits

See Figure 8.

This configuration is for applications requiring DHW circuit flow rates higher than allowable for the boiler, or for high pressure-drop coil-type DHW tanks, connect the piping as in Figure 8. The DHW water only flows through the secondary circuit connection piping. The primary/secondary piping shown ensures the boiler loop will have sufficient flow. It also avoids applying the high head of the boiler circulator to the zone valves.

1. Make sure to size the connection piping (Figure 8, item 23) to handle the total flow it must handle.
2. Install a system circulator (supplied by installer) capable of delivering the proper flow and head as shown.
3. The flow/check valve shown on the boiler outlet piping prevents gravity circulation in the boiler loop during DHW heating.

CAUTION Use **at least** the **MINIMUM** pipe size shown in Figure 4, page 13 on all boiler loop piping (connecting boiler to and from the primary/secondary connection, item 21). **Primary/secondary piping shown** ensures the boiler loop will have sufficient flow. For other piping methods, see guides on page 13.

Expansion Tank required

1. Provide a system expansion tank following the guidelines on page 14.
2. **DO NOT** use a closed-type tank if connecting to a water heater that is equipped with an automatic vent.

Domestic Hot Water (DHW) tank, if used

1. DHW direct connection—Pipe from the near-boiler piping to the DHW tank's boiler connections as shown. See Advanced Manual to configure Boiler Pump to run during DHW demands.
2. DHW as Zone – not applicable to this application.
3. Priority of DHW/Space Heating:
 - a. DHW Priority – DHW is priority over space heating. Use Priority 1 for DHW; Priorities 2 and/or 3 for space heating. The control will not run multiple priorities simultaneously.
 - b. Space Heating Priority – Space heating is priority over DHW. Use Priorities 1 and/or 2 for space heating; Priority 3 for DHW. The control will not run multiple priorities simultaneously.

Controlling the circulators

1. The control can control up to four circulators (boiler circulator and three others). Refer to Field wiring, beginning on page 50, for instructions on wiring to circulators.
2. The factory default settings are: all three inputs are set up for Space Heating (Priority 2). Each input correlates to its respective circulator

Figure 8 Zone valve zoning plus optional DHW piping

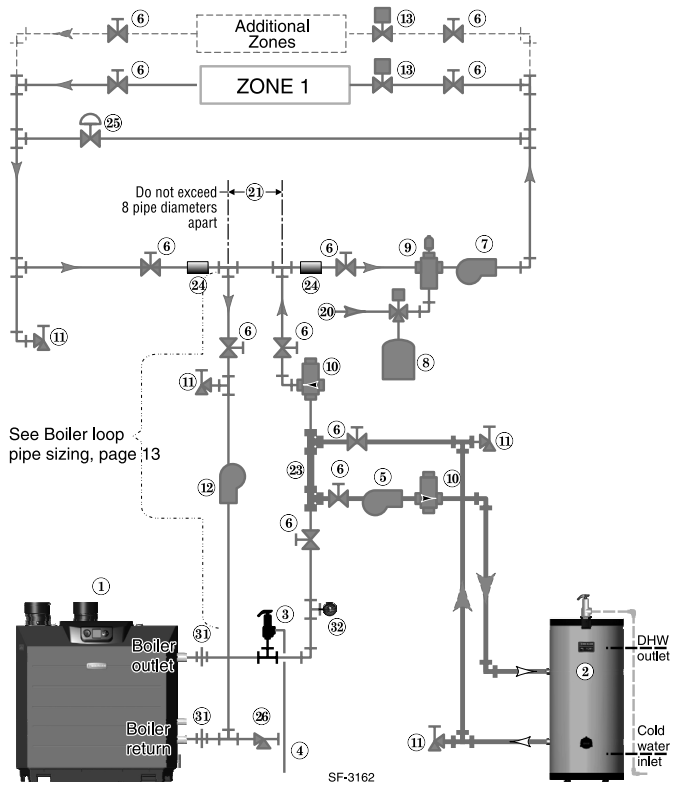

- output. For DHW applications, assign DHW inputs to determined Priority (1, 2 or 3). Priority 1 is defaulted to DHW for DHW Priority applications.
3. For more than 3-zones, use Weil-McLain WMZV zone valve controller.

NOTICE Connect zone valve end switches to a Space Heating Priority input, (default Priority 2) to use default settings. Connect system circulator to corresponding output.

CAUTION Use isolation relays if connecting 3-wire zone valve end switches to the inputs.

Legend — 8

1 SlimFit boiler	12 Boiler circulator
2 Indirect water heater (DHW), if used	13 Zone valves, typical
3 Boiler relief valve (see page 12 for piping details)	20 Make-up water supply
4 Relief valve discharge piping (see page 12 for details)	21 Primary/secondary connection
5 DHW circulator)	23 DHW secondary connector piping — no more than 8 pipe diameters apart.
6 Isolation valves	24 Strap system supply and return sensors to lines as shown, at least 6 pipe diameters (but no more than 3 feet) from boiler connection tees.
7 System circulator (see information above for wiring)	25 Systems using high-head pumps may require a bypass pressure regulator to prevent damage to control valves.
8 Diaphragm (or bladder) type expansion tank (see page 14 for piping of closed-type expansion tank, if used)	26 Boiler drain valve, 3/4" or larger
9 Air separator [with automatic air vent only on systems using diaphragm (or bladder) type expansion tank]	31 Install a union on the boiler supply and return connections as close as possible to the boiler to allow disconnection for service when required.
10 Flow/check valves	32 Pressure/Temperature gauge mounted on boiler outlet.
11 Purge/drain valves	
	■ Items supplied with boiler ■ Items supplied by others



Install water piping *(continued)*

Circulator zoning – primary/secondary (Shown with optional DHW piping) See Figure 9.

This configuration is for circulator-zoned systems using a boiler loop connected as a secondary circuit off of a primary system loop.

1. Install a separate circulator (supplied by installer) for each zone capable of delivering the proper flow and head as shown.
2. The flow/check valve shown on the boiler outlet piping prevents gravity circulation in the boiler loop during DHW heating.

CAUTION Use **at least** the **MINIMUM** pipe size shown in Figure 4, page 13 on all boiler loop piping (connecting boiler to and from the primary/secondary connection, item 21). **Primary/secondary piping shown** ensures the boiler loop will have sufficient flow. For other piping methods, see guides on page 13.

Expansion Tank required

1. Provide a system expansion tank following the guidelines on page 14.
2. **DO NOT** use a closed-type tank if connecting to a water heater that is equipped with an automatic vent.

Domestic Hot Water (DHW) tank, if used

1. DHW direct connection—Pipe from the near-boiler piping to the DHW tank's boiler connections as shown.
2. DHW as zone—A DHW tank can be connected as a zone if a DHW tank is **NOT** already connected to the boiler. See Advanced Manual to configure Boiler Circulator to run during DHW demands and change TARGET MOD SENSOR to System Supply.
3. Priority of DHW/Space Heating:
 - a. DHW Priority – DHW is priority over space heating. Use Priority 1 for DHW; Priorities 2 and/or 3 for space heating. The control will not run multiple priorities simultaneously.
 - b. Space Heating Priority – Space heating is priority over DHW. Use Priorities 1 and/or 2 for space heating; Priority 3 for DHW. The control will not run multiple priorities simultaneously.
 - c. No Priorities – Space heating and DHW can occur simultaneously. Use only if DHW is a zone in system. Assign DHW and Space heating to same Priority. Do not use outdoor reset for this application.

Controlling the circulators

1. The control can control up to four circulators (boiler circulator and three others). Refer to Field wiring, beginning on page 50, for instructions on wiring to circulators. The boiler circulator cannot be used for a zone pump.

Figure 9 Circulator zoning plus optional DHW piping

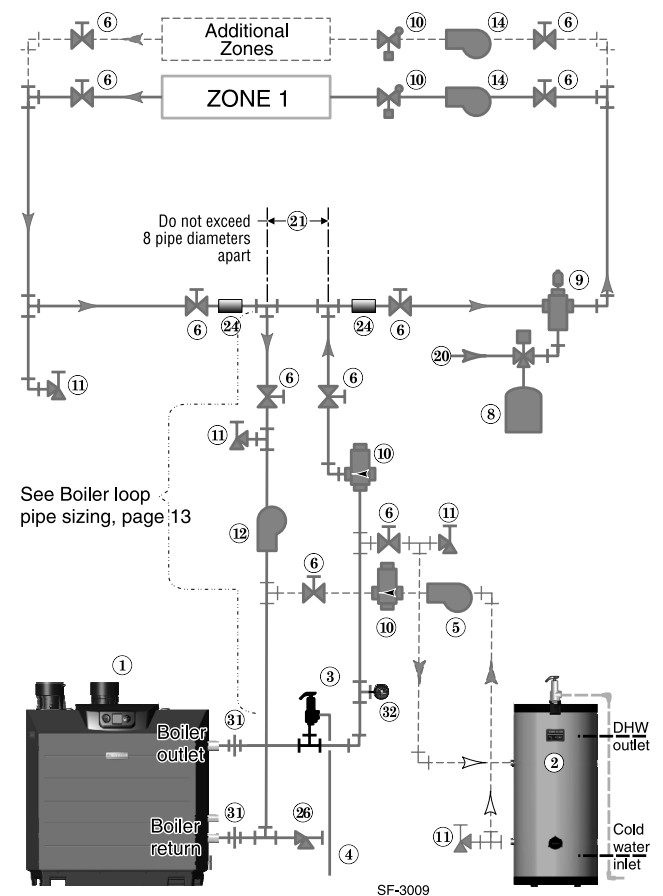

2. The factory default settings are: all three inputs are set up for Space Heating (Priority 2). Each input correlates to its respective circulator output. For DHW applications, assign DHW inputs to determined Priority (1, 2 or 3). Priority 1 is defaulted to DHW for DHW Priority applications.
3. For more than 3-zones, use Weil-McLain WMCR zone Circ controller.

Legend — 9

1 SlimFit boiler	12 Boiler circulator
2 Indirect water heater (DHW), if used	13 Zone valves, typical
3 Boiler relief valve (see page 12 for piping details)	14 Zone circulators, typical
4 Relief valve discharge piping (see page 12 for details)	20 Make-up water supply
5 DHW circulator)	21 Primary/secondary connection
6 Isolation valves	24 Strap system supply and return sensors to lines as shown, at least 6 pipe diameters (but no more than 3 feet) from boiler connection tees.
7 System circulator (see information above for wiring)	26 Boiler drain valve, ¼" or larger
8 Diaphragm (or bladder) type expansion tank (see page 14 for piping of closed-type expansion tank, if used)	31 Install a union on the boiler supply and return connections as close as possible to the boiler to allow disconnection for service when required.
9 Air separator [with automatic air vent only on systems using diaphragm (or bladder) type expansion tank]	32 Pressure/Temperature gauge mounted on boiler outlet.
10 Flow/check valves	■ Items supplied with boiler ■ Items supplied by others
11 Purge/drain valves	



Install water piping *(continued)*

Radiant Heating — Zone valve zoning — primary/secondary (Shown with optional DHW piping) See Figure 10.

The SlimFit boiler is ideal for use in radiant heating. The unique heat exchanger design allows it to work well even in condensing mode. There is no need to regulate boiler return water temperature in radiant heating applications. The primary/secondary piping shown ensures the boiler loop will have sufficient flow. It also avoids applying the high head of the boiler circulator to the zone valves.

1. Apply this configuration for typical radiant heating applications.
2. Size the system piping and circulators to provide the flow and pressure drop needed.
3. The flow/check valve shown on the boiler outlet piping prevents gravity circulation in the boiler loop during DHW heating.

CAUTION Use **at least** the **MINIMUM** pipe size shown in Figure 4, page 13 on all boiler loop piping (connecting boiler to and from the primary/secondary connection, item 21). **Primary/secondary piping shown** ensures the boiler loop will have sufficient flow. For other piping methods, see guides on page 13.

High limit in system piping

1. Add the recommended high limit control (Figure 10, item 22) to help ensure supply water temperature will not exceed the maximum allowable for the radiant system.
2. Wire the limit control to either the manual reset or automatic reset external limit circuit of the Control.

Expansion Tank required

1. Provide a system expansion tank following the guidelines on page 14.
2. **DO NOT** use a closed-type tank if connecting to a water heater that is equipped with an automatic vent.

Domestic Hot Water (DHW) tank, if used

1. DHW direct connection—Pipe from the near-boiler piping to the DHW tank's boiler connections as shown.
2. DHW as zone— Not recommended for this application.
3. Priority of DHW/Space Heating:
 - a. DHW Priority – DHW is priority over space heating. Use Priority 1 for DHW; Priorities 2 and/or 3 for space heating. The control will not run multiple priorities simultaneously.
 - b. Space Heating Priority – Space heating is priority over DHW. Use Priorities 1 and/or 2 for space heating; Priority 3 for DHW. The control will not run for DHW. The control will not run multiple priorities simultaneously.

Controlling the circulators

Figure 10 Typical radiant heating system piping plus optional DHW

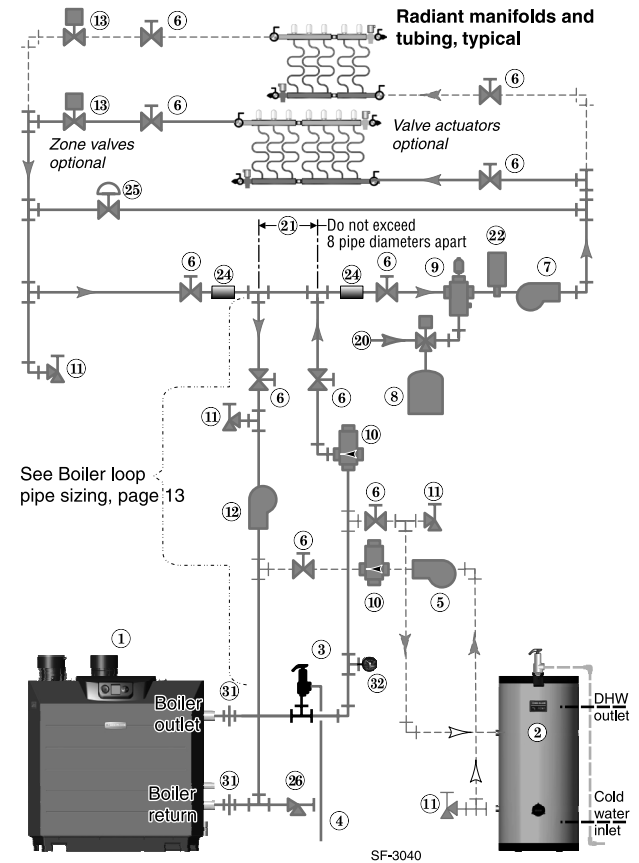

1. The control can control up to four circulators (boiler circulator and three others). Refer to Field wiring, beginning on page 50, for instructions on wiring to circulators.
2. The factory default settings are: all three inputs are set up for Space Heating (Priority 2). Each input correlates to its respective circulator output. For DHW applications, assign DHW Input(s) to determined Priority (1, 2, or 3). Priority 1 is defaulted to DHW for DHW Priority applications.
3. For more than 3-zones, use Weil-McLain WMCR zone Circ controller.

NOTICE Connect zone valve end switches to a Space Heating Priority input, (default Priority 2) to use default settings. Connect system circulator to corresponding output.

Legend — 10

1 SlimFit boiler	13 Zone valves, when used (zoning may also be done using manifold-mounted valve actuators)
2 Indirect water heater (DHW), if used	20 Make-up water supply
3 Boiler relief valve (see page 12 for piping details)	21 Primary/secondary connection (tees no more than 8 pipe diameters apart)
4 Relief valve discharge piping (see page 12 for details)	22 Optional high limit temperature control, set to protect radiant tubing
5 DHW circulator	24 Strap system supply and return sensors to lines as shown, at least 6 pipe diameters (but no more than 3 feet) from boiler connection tees.
6 Isolation valves	25 Systems using high-head pumps may require a bypass pressure regulator to prevent damage to control valves.
7 System circulator (see information above for wiring)	26 Boiler drain valve, 3/4" or larger
8 Diaphragm (or bladder) type expansion tank (see page 14 for piping of closed-type expansion tank, if used)	31 Install a union on the boiler supply and return connections as close as possible to the boiler to allow disconnection for service when required.
9 Air separator [with automatic air vent only on systems using diaphragm (or bladder) type expansion tank]	32 Pressure/Temperature gauge mounted on boiler outlet.
10 Flow/check valves	
11 Purge/drain valves	
12 Boiler circulator	

■ Items supplied with boiler ■ Items supplied by others



Install water piping *(continued)*

WATER CHILLER systems — ZONE VALVES primary/secondary See Figure 11.

1. The chiller must be piped in parallel with the boiler.
2. Use appropriate valves to prevent chilled medium from entering boiler.
3. Circulator zoning option — The space heating system can be zoned with circulators if a separate circulator is supplied for the chilled water loop. Install a separate circulator for each zone.
4. The flow/check valve shown on the boiler outlet piping prevents gravity circulation in the boiler loop during DHW heating.

CAUTION Use **at least the MINIMUM** pipe size shown in **Figure 4, page 13** on all boiler loop piping (connecting boiler to and from the primary/secondary connection, item 21). **Primary/secondary piping shown** ensures the boiler loop will have sufficient flow. For other piping methods, see guides on **page 13**.

NOTICE If antifreeze is used in the system, consider the effects of antifreeze on circulator sizing and DHW performance. Some local codes may require double-wall DHW heat exchanger design. Use only the antifreeze listed by WM Technologies for use with this boiler. See **page 109** for details.

WARNING Chilled medium, if used, is piped in parallel with heating boiler as shown in Figure 11. Use appropriate valves to prevent chilled medium from entering boiler. If boiler is connected to heating coils located in air handling units where they can be exposed to refrigerated air, use flow control valves or other automatic means to prevent gravity circulation during cooling cycle.

Expansion Tank required

1. Provide a system expansion tank following the guidelines on **page 14**.
2. **DO NOT** use a closed-type tank if connecting to a water heater that is equipped with an automatic vent.

Domestic Hot Water (DHW) tank, if used

1. DHW direct connection—Pipe from the near-boiler piping to the DHW tank's boiler connections as shown.
2. DHW as zone— Not recommended for this application.
3. Priority of DHW/Space Heating:
 - a. DHW Priority – DHW is priority over space heating. Use Priority 1 for DHW; Priorities 2 and/or 3 for space heating. The control will not run multiple priorities simultaneously.
 - b. Space Heating Priority – Space heating is priority over DHW. Use Priorities 1 and/or 2 for space heating; Priority 3 for DHW. The control will not run multiple priorities simultaneously.

Controlling the circulators

1. The control can control up to four circulators (boiler circulator and three others). Refer to Field wiring, beginning on **page 50**, for instructions on wiring to circulators.
2. The factory default settings are: all three inputs are setup for Space Heating (Priority 2). Each input correlates to its respective circulator output.

Figure 11 Chilled water system plus optional DHW piping

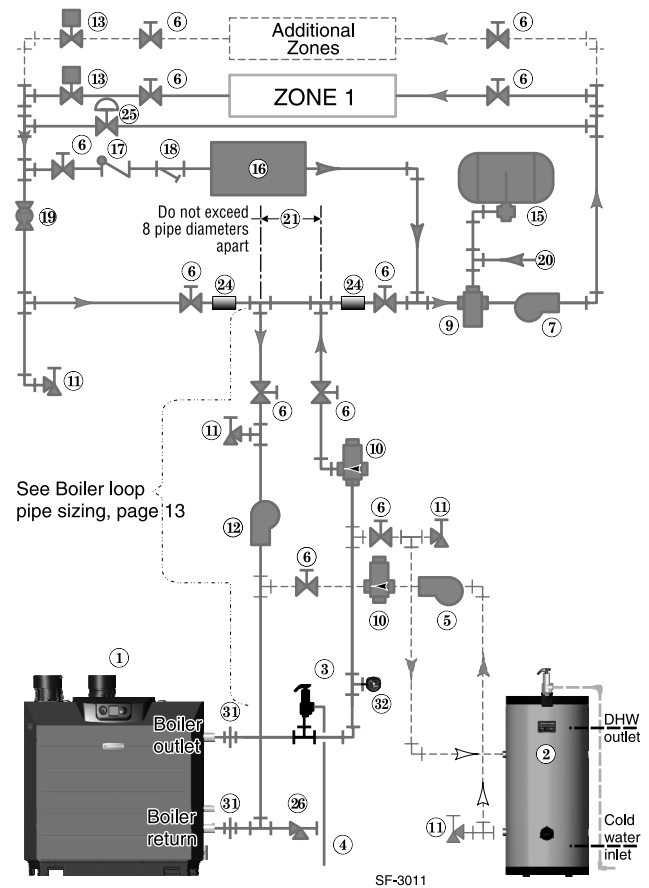

For DHW applications, assign DHW Input(s) to determined Priority (1, 2, or 3). Priority 1 is defaulted to DHW for DHW Priority applications.

3. For more than 3-zones, use Weil-McLain WMZV zone valve controller.

NOTICE Connect zone valve end switches to a Space Heating Priority input, (default Priority 2) to use default settings. Connect system circulator to corresponding output.

CAUTION Use isolation relays if connecting 3-wire zone valve end switches to the inputs.

Legend — 11

1 SlimFit boiler	16 Water chiller
2 Indirect water heater (DHW), if used	17 Check valve
3 Boiler relief valve (see page 12 for piping details)	18 Strainer
4 Relief valve discharge piping (see page 12 for details)	19 Balancing valve
5 DHW circulator	20 Make-up water supply
6 Isolation valves	21 Primary/secondary connection (tees no more than 8 pipe diameters apart)
7 System circulator (see information above for wiring)	24 Strap system supply and return sensors (as shown, at least 6 pipe diameters (but no more than 3 feet) from boiler connection tees.
8 Diaphragm (or bladder) type expansion tank (see page 14 for piping of closed-type expansion tank, if used)	25 Systems using high-head pumps may require a bypass pressure regulator to prevent damage to control valves.
9 Air separator [with automatic air vent only on systems using diaphragm (or bladder) type expansion tank]	26 Boiler drain valve, 3/4" or larger
10 Flow/check valves	31 Install a union on the boiler supply and return connections as close as possible to the boiler to allow disconnection for service when required.
11 Purge/drain valves	32 Pressure/Temperature gauge mounted on boiler outlet.
12 Boiler circulator	
13 Zone valves, typical	■ Items supplied with boiler ■ Items supplied by others
15 Closed-type expansion tank	



Venting/air piping — Massachusetts installations

Venting instructions for the installations in the Commonwealth of Massachusetts

- (a) For all sidewall horizontally-vented gas-fueled equipment installed in every dwelling, building or structure used in whole or in part for residential purposes, including those owned or operated by the Commonwealth and where the side wall exhaust vent termination is less than seven (7) feet above finished grade in the area of the venting, including but not limited to decks and porches, the following requirements shall be satisfied:
1. **INSTALLATION OF CARBON MONOXIDE DETECTORS.** At the time of installation of the side wall horizontal vented gas fueled equipment, the installing plumber or gas fitter shall observe that a hard wired carbon monoxide detector with an alarm and battery back-up is installed on the floor level where the gas equipment is to be installed. In addition, the installing plumber or gas fitter shall observe that a battery operated or hard wired carbon monoxide detector with an alarm is installed on each additional level of the dwelling, building or structure served by the side wall horizontal vented gas fueled equipment. It shall be the responsibility of the property owner to secure the services of qualified licensed professionals for the installation of hard wired carbon monoxide detectors
 - a. In the event that the side wall horizontally vented gas fueled equipment is installed in a crawl space or an attic, the hard wired carbon monoxide detector with alarm and battery back-up may be installed on the next adjacent floor level.
 - b. In the event that the requirements of this subdivision can not be met at the time of completion of installation, the owner shall have a period of thirty (30) days to comply with the above requirements; provided, however, that during said thirty (30) day period, a battery operated carbon monoxide detector with an alarm shall be installed.
 2. **APPROVED CARBON MONOXIDE DETECTORS.** Each carbon monoxide detector as required in accordance with the above provisions shall comply with NFPA 720 and be ANSI/UL 2034 listed and IAS certified.
 3. **SIGNAGE.** A metal or plastic identification plate shall be permanently mounted to the exterior of the building at a minimum height of eight (8) feet above grade directly in line with the exhaust vent terminal for the horizontally vented gas fueled heating appliance or equipment. The sign shall read, in print size no less than one-half (1/2) inch in size, "GAS VENT DIRECTLY BELOW. KEEP CLEAR OF ALL OBSTRUCTIONS."
 4. **INSPECTION.** The state or local gas inspector of the side wall horizontally vented gas fueled equipment shall not approve the installation unless, upon inspection, the inspector observes carbon monoxide detectors and signage installed in accordance with the provisions of 248 CMR 5.08(2)(a) 1 through 4.
- (b) **EXEMPTIONS:** The following equipment is exempt from 248 CMR 5.08(2)(a)1 through 4:
1. The equipment listed in Chapter 10 entitled "Equipment Not Required To Be Vented" in the most current edition of NFPA 54 as adopted by the Board; and
 2. Product Approved side wall horizontally vented gas fueled equipment installed in a room or structure separate from the dwelling, building or structure used in whole or in part for residential purposes.
- (c) **MANUFACTURER REQUIREMENTS — GAS EQUIPMENT VENTING SYSTEM PROVIDED.** When the manufacturer of Product Approved side wall horizontally vented gas equipment provides a venting system design or venting system components with the equipment, the instructions provided by the manufacturer for installation of the equipment and the venting system shall include:
1. Detailed instructions for the installation of the venting system design or the venting system components; and
 2. A complete parts list for the venting system design or venting system.
- (d) **MANUFACTURER REQUIREMENTS — GAS EQUIPMENT VENTING SYSTEM NOT PROVIDED.** When the manufacturer of a Product Approved side wall horizontally vented gas fueled equipment does not provide the parts for venting the flue gases, but identifies "special venting systems", the following requirements shall be satisfied by the manufacturer:
1. The referenced "special venting system" instructions shall be included with the appliance or equipment installation instructions; and
 2. The "special venting systems" shall be Product Approved by the Board, and the instructions for that system shall include a parts list and detailed installation instructions.
- (e) A copy of all installation instructions for all Product Approved side wall horizontally vented gas fueled equipment, all venting instructions, all parts lists for venting instructions, and/or all venting design instructions shall remain with the appliance or equipment at the completion of the installation.

Venting/combustion air — general

Vent and air piping materials

- See [Figure 13, page 23](#) for approved vent and air piping materials, for both **direct exhaust** and **direct vent**.

WARNING Use the same vent or air piping material throughout. — Do not connect different types of piping together.

WARNING **Stainless steel pipe** — Install Dura-Vent – FasNSeal™ adapter at each boiler fitting where stainless steel pipe will be connected. Adapter is available from Dura-Vent or WM Technologies (see [page 109](#) for part number).

Vent piping

- Boiler flue gases must be piped from the boiler to outside, following the instructions in this manual, and compliant with all applicable codes. The vent pipe must terminate either through the sidewall or through the roof, located with the correct separation from the air termination. See the associated instructions in the following pages.
- Each SlimFit boiler requires a separate vent. **DO NOT** common vent.

DIRECT EXHAUST OPTIONS

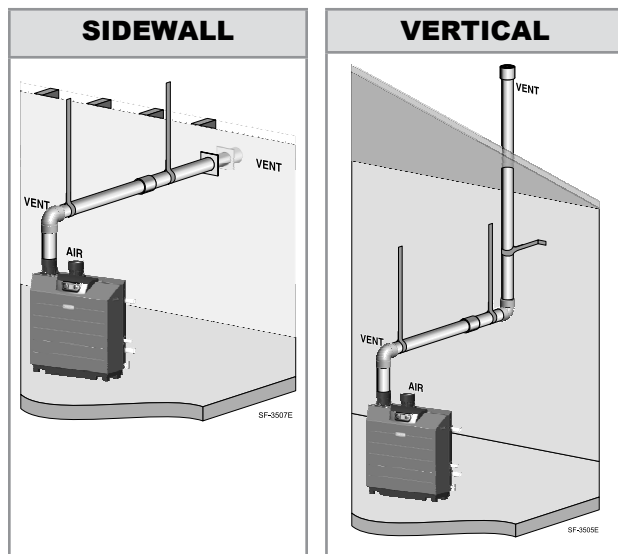

Combustion air openings for direct exhaust

- Combustion air must be supplied through openings into the boiler room, following the instructions in this manual, and compliant with all applicable codes. Read the warning in [Figure 12, page 22](#), and ensure the air and boiler room will not contain contaminated air.
- Where the SlimFit boiler shares a space with other appliances, the combustion air openings must be sized to handle the combined requirements of all appliances in the space.

SIDEWALL direct exhaust option

- Read [page 23](#) through [page 30](#). Then go to [page 31](#).

VERTICAL direct exhaust option

- Read [page 23](#) through [page 30](#). Then go to [page 34](#).

DIRECT VENT OPTIONS

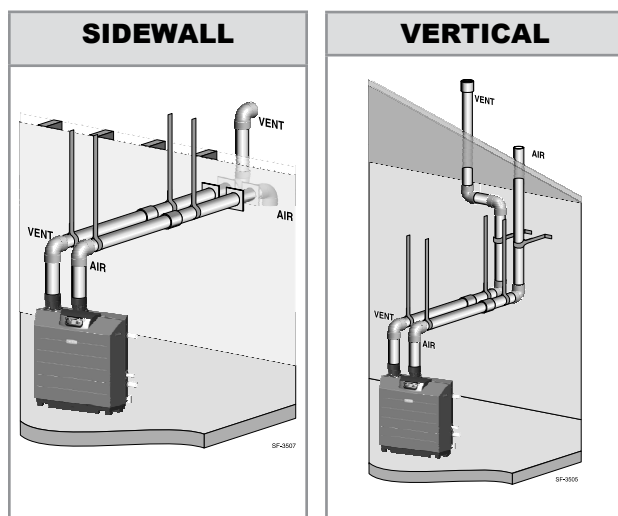

Combustion air piping for direct vent

- Combustion air must be piped from outside to the boiler, following the instructions in this manual, and compliant with all applicable codes. Read the warning in [Figure 12, page 22](#), and ensure the air intake will not be likely to draw in contaminated air.
- Combustion air can be piped individually for each boiler, or it can be manifolded as shown in [Figure 26, page 36](#). Combustion/ventilation openings may also be required in boiler room walls, per instructions in this manual and applicable codes.

SIDEWALL direct vent option

- Read [page 23](#), [page 20](#) and [page 36](#). Then go to [page 38](#).

VERTICAL direct vent option

- Read [page 23](#), [page 20](#) and [page 36](#). Then go to [page 42](#).



Venting/combustion air — general *(continued)*

⚠ DANGER SlimFit Boilers must be vented and supplied with combustion and ventilation air using piping and methods described in this manual.

DO NOT COMMON VENT

Every boiler must have its own vent. DO NOT common vent with any other appliance. See [page 23](#) for checking appliances remaining on a common vent.

INSPECT VENT/AIR COMPONENTS

Inspect finished vent and air piping thoroughly to ensure all are airtight and comply with the instructions provided and with all requirements of applicable codes. Verify all air openings are correctly sized, unobstructed, and free of airborne contaminants.

Failure to provide a properly-installed vent and air system will cause severe personal injury or death.

Code compliance

⚠ WARNING Installations must comply with local requirements and with the National Fuel Gas Code, ANSI Z223.1 for U.S. installations or CSA B149.1 or B149.2 for Canadian installations.

Vent and air piping materials

⚠ WARNING Use only the materials listed in this manual ([Figure 13, page 23](#)) for vent and air pipe and fittings.

A masonry chimney can ONLY be used as a chase for vent and air piping

⚠ WARNING If used, a masonry chimney can ONLY be used as a PIPE CHASE for vent and air pipes — The vent and air piping must be installed as instructed in this manual and all joints must be sealed. The chimney must be used only as a chase for the SlimFit boiler vent/air piping. NO OTHER appliance or fireplace can be connected to the chimney.

The chimney must be straight, with no offsets, and the vent and air piping materials must comply with this instruction manual.

The chimney must be fitted with a sealed access opening, through which the interior of the chimney can be inspected.

The chimney and liner must be inspected at least once annually to verify condition.

Failure to comply could result in severe personal injury, death or substantial property damage.

Combustion air contamination

1. **Direct exhaust** (combustion air from boiler room):
 - a. Provide combustion air openings to boiler room as described in this manual.
 - b. Ensure the boiler room and combustion air source areas are free of contaminants.
2. **Direct vent** (piped combustion air):
 - a. Install air inlet piping for the SlimFit boiler as described in this manual.
 - b. Do not terminate air piping in locations that can allow contamination of combustion air.
3. See [Figure 12](#) for products and areas which may cause contaminated combustion air.

Figure 12 Corrosive contaminants and sources

Products to avoid
Spray cans containing chloro/fluorocarbons
Permanent wave solutions
Chlorinated waxes/cleaners
Chlorine-based swimming pool chemicals
Calcium chloride used for thawing
Sodium chloride used for water softening
Refrigerant leaks
Paint or varnish removers
Hydrochloric acid/muriatic acid
Cements and glues
Antistatic fabric softeners used in clothes dryers
Chlorine-type bleaches, detergents, and cleaning solvents found in household laundry rooms
Adhesives used to fasten building products and other similar products
Excessive dust and dirt

Areas likely to have contaminants
Dry cleaning/laundry areas and establishments
Swimming pools
Metal fabrication plants
Beauty shops
Refrigeration repair shops
Photo processing plants
Auto body shops
Plastic manufacturing plants
Furniture refinishing areas and establishments
New building construction
Remodeling areas
Garages with workshops



Venting/combustion air — options (Category II & IV)

Figure 13 Use only the materials listed below, ensuring that all materials meet local codes

Item/Material	Supplier/Manufacturer (See WARNING below)	Standards for installations in:		
		United States		Canada
		Vent or air piping	Vent piping	Air piping
Polypropylene	DuraVent / M&G – Polypro	Certified for Category IV and direct vent appliance venting.	Certified for Category IV and direct vent appliance venting.	
	Centrotherm Eco Systems – InnoFlue® Single-wall	Certified for Category IV and direct vent appliance venting.	Certified for Category IV and direct vent appliance venting.	
Vent or air pipe & fittings	PVC schedule 40	ANSI/ASTM D1785	ULC S636	PVC, PVC-DWV, CPVC
	PVC-DWV schedule 40	ANSI/ASTM D2665	NA	
	CPVC schedule 40	ANSI/ASTM F441	ULC S636	
PVC & ABS pipe cement & primer	PVC	ANSI/ASTM D2564/F656	ULC S636	Use only cement and primer suitable for piping material used.
	CPVC	ANSI/ASTM F493	ULC S636	
AL29-4C stainless steel	Dura-Vent – FasNSeal™	Certified for Category IV and direct vent appliance venting.	Certified for Category IV and direct vent appliance venting.	

WARNING **Stainless steel pipe** — Install Dura-Vent – FasNSeal™ adapter at each boiler fitting where stainless steel pipe will be connected. Adapter is available from Dura-Vent or WM Technologies (see page 109 for part number).

Appliances remaining on an existing vent system

DANGER Do not install the SlimFit boiler into a common vent with any other appliance. This will cause flue gas spillage or appliance malfunction, resulting in possible severe personal injury, death or substantial property damage.

WARNING Existing common vent systems may be too large for the appliances remaining connected after the existing boiler is removed.

WARNING Failure to follow all instructions can result in flue gas spillage and carbon monoxide emissions, causing severe personal injury or death.

When removing a boiler from an existing common vent system

The SlimFit boiler cannot be common vented with any other appliance. When an existing boiler is replaced with an SlimFit boiler, the SlimFit boiler CANNOT use the existing common vent. The SlimFit boiler requires its own vent and air piping, as specified in this manual. This may cause a problem for the appliances that remain on the old common vent, because the vent may be too large. The following test is intended to check for proper operation of the appliances remaining on the old common vent system.

Vent system verification

At the time of removal of an existing boiler, the following steps shall be followed with each appliance remaining connected to the common venting system placed in operation, while the

other appliances remaining connected to the common venting system are not in operation. Seal any unused openings in the common venting system.

Existing vent test procedure

(The following is intended to test whether the appliances remaining on an existing vent system will operate satisfactorily.)

1. Visually inspect the venting system for proper size and horizontal pitch and determine there is no blockage or restriction, leakage, corrosion or other deficiencies which could cause an unsafe condition.
2. Test vent system — Insofar as is practical, close all building doors and windows and all doors between the space in which the appliances remaining connected to the common venting system are located and other spaces

of the building. Turn on clothes dryers and any appliance not connected to the common venting system. Turn on any exhaust fans, such as range hoods and bathroom exhausts, so they will operate at maximum speed. Do not operate a summer exhaust fan. Close fireplace dampers.

3. Place in operation the appliance being inspected. Follow the lighting instructions. Adjust thermostat so appliance will operate continuously.
4. Test for spillage at draft hood relief opening after 5 minutes of main burner operation. Use the flame of a match or candle, or smoke from a cigarette, cigar, or pipe.
5. After it has been determined that each appliance remaining connected to the common venting system properly vents when tested as outlined herein, return doors, windows, exhaust fans, fireplace dampers, and any other gas-burning appliance to their previous conditions of use.
6. Any improper operation of common venting system should be corrected so the installation conforms with the National Fuel Gas Code, ANSI Z223.1 — latest edition. Correct by re-sizing to approach the minimum size as determined using the appropriate tables in Part 13 of that code. Canadian installations must comply with B149.1 or B149.2 Installation Code.



Venting/combustion air — options (Category II)

Category II Requirements

In addition to the SlimFit boilers Category IV rating (positive pressure, likely to condense), SlimFit boilers are approved for Category II (negative pressure, likely to condense) as well.

This new venting option includes / requires:

- The Vent system for a Category II SlimFit boiler is considered a Designed / Engineered vent system and should be designed by a professional using accepted engineering practices in accordance to local authority having jurisdiction.
- Vertical Vent only.
- Must not be installed into an existing common vent system with other appliances.
- Combustion air must come from the boiler room. See Boiler Room Air opening requirements.
- Must increase venting to 6” or 8” using a 8” to 6” bell reducer at boiler vent adapter for Category II vent connections.
- The Vent System should be designed so that the pressure in the vertical vent pipe immediately following the bell re-

ducer is between the ranges provided in the Table 1, below, during all running (burner lit) conditions (i.e., High Fire through Low Fire).

- Flue gas temperature should not exceed 210°F, the boiler will shut down and recycle if it does. The flue gas temperature should typically be within 20°F of the return water temperature of the boiler. If there is the potential for a wide variation in return water temperatures, the lowest possible temperature should be used for any calculations.
- Stack / Vent Flow Rate for each individual boiler model is listed in the table below. This flow rate is based on the unit running at 9.25% CO₂ and the maximum flue gas temperature of 216°F. The values can vary depending on the location of the installation and operating conditions.
- A carbon monoxide detector(s) is required in the boiler room for SlimFit boilers installed in a Category II configuration. The carbon monoxide detector must be wired on the same electrical circuit as the boiler. Check your local codes for any additional requirements of carbon monoxide detectors.

Table 1 Rating and Vent Data for Category II boilers

<i>Boiler Model</i>	<i>Input Btuh</i>	<i>Stack / Vent flow rate scfm</i>	<i>Negative Pressure to be maintained at Vent Connection of the boiler Inches w.c.</i>	<i>SlimFit Vent Adapter required for Category II (See Note 1)</i>
SF-550	550,000	128	-0.001 to -0.100	6-8”
SF-750	750,000	175	-0.001 to -0.100	6-8”

Note 1: 8 to 6” bell adapters are required for Category II venting.

WARNING Improper Installation of a Category II vent system resulting in positive pressure in the vent system can result in flue gas spillage and carbon monoxide emissions, causing severe personal injury or death.

NOTICE WM Technologies recommends the use of a Variable Speed Chimney Fan/ Power venter to ensure that the appropriate negative pressure is maintained for Category II venting. This is recommended because, as a result of the boiler’s efficiency, the exhaust gas temperatures can be quite low resulting in less natural draft. A flow proving switch should be wired into the Proof of Closure jumper circuit on the boiler control. See the boiler manual for additional information. The use of this device should be considered in any Engineered Vent system.

NOTICE WM Technologies recommends the use of a Double Acting Barometric Damper or Modulating Damper to ensure the appropriate negative pressure range is kept for Category II venting. The use of this device should be considered in any Engineered Vent system.

NOTICE When using a damper of any kind, it is recommended to use a thermal spill switch to detect any exhaust flow into the boiler room. Verify the temperature range on the thermal spill switch is adequate for the Flue gas temperature from the SlimFit boiler. The use and set-point of this shall be determined by the system designer. The Auto reset input on the Boiler’s control can be used to wire in the thermal spill switch.

NOTICE Increasing the negative pressure in the vent pipe will slightly increase the firing rate at low fire, thus reducing the boiler’s true modulation range. Consider this factor during system design.

Code Compliance

WARNING Venting / Combustion air piping – Installations must provide provisions for combustion and ventilation air in accordance with the section “Venting of Equipment”, of the National Fuel Gas Code, ANSI Z223.1 / NFPA 54, or “Venting Systems and Air Supply for appliances” of the Natural Gas and Propane Installation Code, CAN/CSA B149.1, or applicable provisions of the local building codes.



Direct Exhaust (Category II Only) Venting – general

⚠ DANGER SlimFit Boilers must be vented and supplied with combustion and ventilation air using piping and methods described.

Inspect finished vent and air piping thoroughly to ensure all are water-tight and comply with the instructions provided and with all requirements of applicable codes.

Failure to provide a properly-installed vent and air system will cause severe personal injury or death.

NOTICE If the vent/air piping configurations covered in the SlimFit boiler manual cannot be applied for a particular installation, contact WM Technologies for assistance. Other configurations may be available.

⚠ WARNING Installations must comply with local requirements and with the National Fuel Gas Code, ANSI Z223.1 for U.S. installations or CSA B149.1 or B149.2 for Canadian installations.

⚠ WARNING Use only the materials listed in the Boiler manual for vent and air pipe and fittings. Failure to comply could result in severe personal injury, death or substantial property damage.

⚠ WARNING If used, a masonry chimney can ONLY be used as a PIPE CHASE for vent pipe — The vent piping must be installed as instructed in this manual and all joints must be sealed. The chimney must be used only for boilers. NO OTHER appliance or fireplace can be connected to the chimney.

The chimney must be straight, with no offsets, and the vent and air piping materials must comply with this instruction manual. The chimney must be fitted with a sealed access opening, through which the interior of the chimney can be inspected. The chimney (and liner, if installed) must be inspected at least once annually to verify condition.

Failure to comply could result in severe personal injury, death or substantial property damage.

Vent piping

Boiler flue gases must be piped from the boiler to outside, following the instructions in the Boiler manual, and compliant with all applicable codes.

Combustion and ventilation air openings (direct exhaust installations)

Combustion and ventilation air are provided from the boiler room on direct exhaust installations. Follow all instructions in the Boiler manual, plus all applicable codes, to provide required air openings.

Vent termination options

Vent piping must terminate out through the roof of the building, using only one of the methods described in the Boiler manual.

Vent pipe diameter

A 6" or 8" vent pipe diameter must be used.

Vent pipe minimum length

Direct exhaust — no minimum.

Vent and air piping materials

See the SlimFit Boiler Manual for approved vent and air piping materials, for **direct exhaust**.

⚠ WARNING Use the same vent or air piping material throughout. — Do not connect different types of piping together.

Install a bird screen in each vent pipe termination (coupling or elbow). Bird screens are not supplied with the SlimFit boiler. Purchase separately from WM Technologies.



Direct Exhaust (Category II Only) Boiler room air opening

Combustion air openings for direct exhaust

▲WARNING Provide combustion air openings to boiler room and building. Combustion and ventilation air for direct exhaust boilers is provided from the boiler room. Follow all instructions in the Boiler manual plus all applicable codes, providing combustion air openings as specified. Failure to comply could result in severe personal injury, death or substantial property damage.

1. Combustion air must be supplied through openings into the boiler room, following the instructions in this manual and compliant with all applicable codes. Read the warning in [Figure 12, page 22](#), and ensure the air and boiler room will not contain contaminated air.
2. Where the boiler shares a space with other appliances, the combustion air openings must be sized to handle the combined requirements of all appliances in the space.

Sizing combustion air openings

Air openings provide for ventilation (as well as combustion air) to prevent overheating of the boiler controls and boiler space. Air is also needed for other appliances located in the same space.

Use [Figure 1, page 6](#), selecting the appropriate installation conditions.

▲WARNING Air openings must be sized to handle all appliances and air movers (exhaust fans, etc.) using the air supply.

The sizing given in [Figure 1, page 6](#), is based on the National Fuel Gas Code, ANSI Z223.1, allowing adequate air openings for gravity-vented gas appliances (Category I) in addition to that needed for the SlimFit boiler.

The air openings recommended in [Figure 1, page 6](#), will allow adequate ventilation and combustion air provided the boiler room is not subjected to negative pressure due to exhaust fans or other mechanical ventilation devices.

Refer to the National Fuel Gas Code for dealing with other conditions.

Free area — louver allowance

The free area of openings means the area after reduction for any installed louvers or grilles. Be sure to consider this reduction when sizing the air openings.

Special considerations

Tight construction

ANSI Z223.1 defines unusually tight construction where:

1. Walls and ceilings exposed to the outside atmosphere have a continuous water vapor retarder with a rating of 1 perm or less with openings gasketed, and . . .
2. Weather-stripping has been added on openable windows and doors, and . . .

3. Caulking or sealants are applied to areas such as joints around windows and door frames, between sole plates and floors, between wall-ceiling joints, between wall panels, at penetrations for plumbing, electrical, and gas lines, and in other openings.

For buildings with such construction, provide air openings into the building from outside, sized per the appropriate case in [Figure 1, page 6](#), if appliances are to use inside air for combustion and ventilation.

Exhaust fans and air movers

The appliance space must never be under a negative pressure unless all appliances are installed as direct vent. Always provide air openings sized not only to the dimensions required for the firing rate of all appliances, but also to handle the air movement rate of the exhaust fans or air movers using air from the building or space.

Motorized air dampers

If the air openings are fitted with motorized dampers, electrically interlock the damper to:

- Prevent the boiler from firing if the damper is not fully open.
- Shut the boiler down should the damper close during boiler operation.

The SlimFit control provides a Proof of Closure function which will prevent the boiler from firing if the damper is not fully open or closes during boiler operation. Please refer to the Boiler Manual for installation and wiring instructions.

▲WARNING Every vent pipe requires a **bird screen at its termination**. Bird screens are not supplied with the SlimFit boiler. Purchase separately from WM Technologies.

Direct Exhaust (Category II Only) – Vertical

Figure 14 DIRECT EXHAUST vertical termination

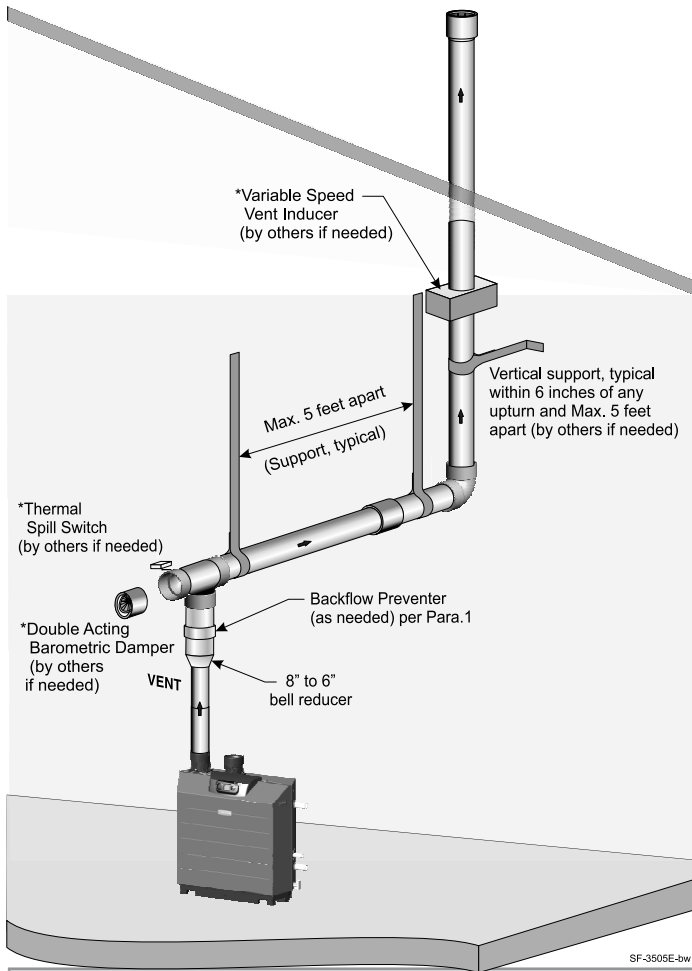

DIRECT EXHAUST — Vertical termination — installation sequence overview

- Step 1** Install the boiler.
- Step 2** Determine the proper location for wall penetration for each termination.
- Prepare roof penetrations before installing vent piping.
 - Finish by attaching external pipe and fittings as shown in the termination instructions.
 - Install terminations as described in this manual.
 - Support vertical runs on the outside of the building with brackets as shown in the termination instructions.
- Step 3** Install vent piping from boiler to termination.
- Install a hanger support within 6 inches of any upturn in the piping.
 - Install pipe supports every 5 feet on both the horizontal and vertical runs.
 - Slope horizontal piping downward toward the boiler at least 1/4 inch per foot.
- Step 4** Connect the vent piping at the boiler per manual instructions.

Determine location for vertical termination

1. Locate the vent termination using the following guidelines:
2. The vent piping must terminate in a coupling as shown in [Figure 15, page 28](#).
3. Consider the surroundings when terminating the vent:
 - a. Position the vent termination where vapors will not damage nearby shrubs, plants or air conditioning equipment or be objectionable.
 - b. The flue products will form a noticeable plume as they condense in cold air. Avoid areas where the plume could obstruct window views.
 - c. Prevailing winds could cause freezing of condensate and water/ice buildup where flue products impinge on building surfaces or plants.
 - d. Avoid possibility of accidental contact of flue products with people or pets.
 - e. Do not locate the termination where wind eddies could affect performance or cause recirculation, such as inside building corners, near adjacent buildings or surfaces, window wells, stairwells, alcoves, courtyards or other recessed areas.
 - f. Locate or guard vent to prevent condensate damage to exterior finishes.
4. Maintain clearances as shown in the illustrations in this manual section. Also maintain the following:
 - a. Vent must terminate:
 - At least 12 inches above roof or snow line as shown in [Figure 15, page 28](#).
 - At least 6 feet from adjacent walls.
 - No closer than 5 feet below roof overhang.
 - At least 3 feet above any forced air intake within 10 feet.
 - No closer than 48 inches below or horizontally from any door or window or any other gravity air inlet.
 - b. Do not terminate closer than 4 feet horizontally from any electric meter, gas meter, regulator, relief valve or other equipment.
5. Where the vent penetrates the roof, the annular space around the penetration must be permanently sealed using approved materials to prevent entry of combustion products into the building.
6. Locate terminations so they are not likely to be damaged by foreign objects, such as stones or balls, or subject to buildup of leaves or sediment.
7. Do not connect any other appliance to the vent pipe.

Prepare roof penetration

1. Vent pipe penetration:
 - a. Cut a hole for the vent pipe. For either combustible or noncombustible construction, size the vent pipe hole at least 0.5" larger than the vent pipe diameter – use a 7" hole for 6" PVC or PP.
 - b. Insert a galvanized metal thimble in the vent pipe hole.
2. Follow all local codes for isolation of vent pipe when passing through floors, ceilings and roofs.
3. Provide flashing and sealing boots sized for the vent pipe and air pipe.

Direct Exhaust (Category II Only) – Vertical *(continued)*

Termination and fittings

1. Prepare the vent termination coupling (Figure 15) by inserting a bird screen. Bird screens are not supplied with the SlimFit boiler. Purchase separately from WM Technologies.
2. The vent piping must terminate in a coupling as shown in Figure 15.
3. Maintain the required dimensions of the finished termination piping as shown in Figure 15.
4. Do not extend exposed vent pipe outside of building more than shown in Figure 15. Condensate could freeze and block vent pipe.

Multiple vent terminations

When terminating multiple SlimFit boilers, terminate each vent connection as described in this section. Space terminations as required for best installation practices and required maintenance.

Complete termination preparation

Install vent terminations before proceeding. See previous pages for instructions.

Installing direct exhaust vent piping

1. For reference in the following see:
 - a. Vertical terminations: see [Figure 14, page 27](#).
2. Work from the boiler to vent or air termination. Do not exceed the lengths given in the previous pages for either the air or vent piping.
 - a. You must install appropriate pipe reducers, where required, at the boiler vent connection.
3. Cut pipe to required lengths.
4. Deburr inside and outside of pipe ends.
5. Chamfer outside of each pipe end to ensure even cement distribution when joining.
6. Clean all pipe ends and fittings. Dry thoroughly.
7. Dry assemble entire vent or air piping to ensure proper fit before assembling any joint.
8. For each PVC/CPVC joint:
 - a. Handle fittings and pipes carefully to prevent contamination of surfaces.
 - b. For PVC/CPVC apply primer liberally to both joint surfaces — pipe end and fitting socket.
 - c. While primer is still damp, lightly apply approved cement to both surfaces in a uniform coating.
 - d. Apply a second coat to both surfaces. Avoid using too much cement on sockets to prevent cement buildup inside.
 - e. With cement still wet, insert pipe into fitting, twisting $\frac{1}{4}$ turn. Make sure pipe is fully inserted.
 - f. Wipe excess cement from joint. Check joint to be sure a smooth bead of cement shows around the entire joint.
9. For polypropylene applications follow manufacturer's instructions for preparation and assembly.
10. Install pipe supports as shown on [Figure 14, page 27](#).
11. Slope vent and air piping continuously toward boiler, with at least $\frac{1}{4}$ inch drop per foot of run. Do not allow sags at any point.
12. Maintain minimum clearance of $\frac{3}{16}$ inch between vent pipe and any combustible wall or material.
13. Seal wall or floor penetration openings following local code requirements.

Figure 15 DIRECT EXHAUST — Vertical termination

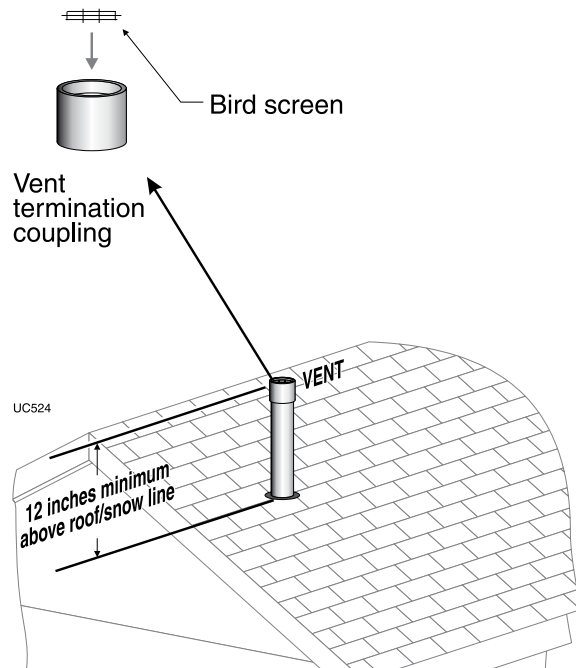



DIRECT EXHAUST — Boiler room air openings

Combustion air provision

The SlimFit Commercial boiler can use inside air if no contaminants are present in the boiler space. (If contaminants are likely to be present, install the boiler as a direct vent appliance, using the appropriate vent instructions in this manual, see [Figure 12, page 22](#))

The boiler room must be fitted with combustion air openings large enough to provide air for all appliances in the room. Use the following information to size the openings. Ensure the installation complies with all applicable codes and standards.

Sizing combustion air openings

Air openings provide for ventilation (as well as combustion air) to prevent overheating of the boiler controls and boiler space. Air is also needed for other appliances located in the same space.

Use [Figure 16, page 30](#), selecting the appropriate installation conditions.

⚠ WARNING Air openings must be sized to handle all appliances and air movers (exhaust fans, etc.) using the air supply.

The sizing given in [Figure 16, page 30](#) is based on the National Fuel Gas Code, ANSI Z223.1, allowing adequate air openings for gravity-vented gas appliances (Category I) in addition to that needed for the SlimFit boiler.

The SlimFit Commercial boiler is rated Category IV (pressurized vent), and has varying requirements for combustion and ventilation air, reflected by the special sizing instructions given in this manual.

The air openings recommended in [Figure 16, page 30](#) will allow adequate ventilation and combustion air provided the boiler room is not subjected to negative pressure due to exhaust fans or other mechanical ventilation devices.

Refer to the National Fuel Gas Code for dealing with other conditions.

Free area — louver allowance

The free area of openings means the area after reduction for any installed louvers or grilles. Be sure to consider this reduction when sizing the air openings.

Special considerations

Tight construction

ANSI Z223.1 defines unusually tight construction where:

1. Walls and ceilings exposed to the outside atmosphere have a continuous water vapor retarder with a rating of 1 perm or less with openings gasketed, and . . .
2. Weather-stripping has been added on openable windows and doors, and . . .
3. Caulking or sealants are applied to areas such as joints around windows and door frames, between sole plates and floors, between wall-ceiling joints, between wall panels, at penetrations for plumbing, electrical, and gas lines, and in other openings.

For buildings with such construction, provide air openings into the building from outside, sized per the appropriate case in [Figure 16, page 30](#) if appliances are to use inside air for combustion and ventilation.

Exhaust fans and air movers

The appliance space must never be under a negative pressure unless all appliances are installed as direct vent. Always provide air openings sized not only to the dimensions required for the firing rate of all appliances, but also to handle the air movement rate of the exhaust fans or air movers using air from the building or space.

Motorized air dampers

If the air openings are fitted with motorized dampers, electrically interlock the damper to:

- Prevent the boiler from firing if the damper is not fully open.
- Shut the boiler down should the damper close during boiler operation.

To accomplish this interlock, wire an isolated contact (proving the damper open) in series with the thermostat input to the boiler. The boiler will not start if this contact is open, and will shut down should it open during operation.



DIRECT EXHAUST — Boiler room air openings *(continued)*

Figure 16 MINIMUM combustion air openings for direct exhaust applications — **ALL OPENING SIZES ARE FREE AREA** Provisions for combustion and ventilation air to be in accordance with the section “Air for Combustion and Ventilation,” of the National Fuel Gas Code, ANSI Z223.1/NFPA 54, or applicable provisions of the local building codes.

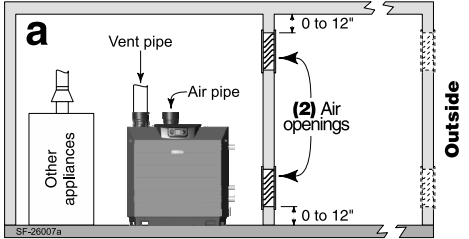
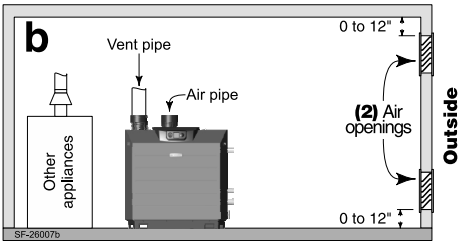
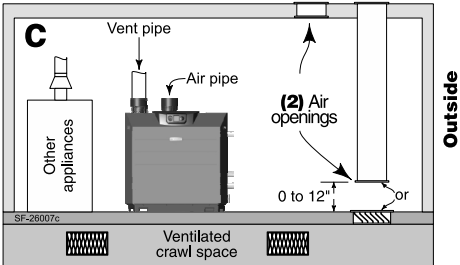
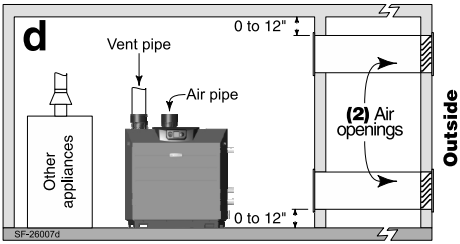
<p>Air openings</p> <p>The required air opening sizes below are FREE AREA, after reduction for louver obstruction. Note the exception below for large spaces.</p>	<p>SlimFit boiler WITH other appliances in room</p>	<p>SlimFit boiler WITHOUT other appliances in room</p>
	<p>TWO openings, each at least: 1 square inch per 1,000 Btuh of all appliances in the room</p>	<p>TWO openings, each at least: 1 square inch per 4,000 Btuh of all appliances in the room</p>
	<p>TWO openings, each at least: 1 square inch per 4,000 Btuh of all appliances in the room — OR — ONE opening **, each at least: 1 square inch per 3,000 Btuh of all appliances in the room</p>	<p>TWO openings, each at least: 1 square inch per 4,000 Btuh of all appliances in the room — OR — ONE opening **, each at least: 1 square inch per 3,000 Btuh of all appliances in the room</p>
<p>Outside or ventilated attic</p> 	<p>TWO openings, each at least: 1 square inch per 2,000 Btuh of all appliances in the room — OR — ONE opening **, each at least: 1 square inch per 3,000 Btuh of all appliances in the room</p>	<p>TWO openings, each at least: 1 square inch per 4,000 Btuh of all appliances in the room — OR — ONE opening **, each at least: 1 square inch per 3,000 Btuh of all appliances in the room</p>
	<p>TWO openings, each at least: 1 square inch per 4,000 Btuh of all appliances in the room — OR — ONE opening **, each at least: 1 square inch per 3,000 Btuh of all appliances in the room</p>	<p>TWO openings, each at least: 1 square inch per 4,000 Btuh of all appliances in the room — OR — ONE opening **, each at least: 1 square inch per 3,000 Btuh of all appliances in the room</p>
<p>** NOTICE: Requirements for using the SINGLE air opening option.</p>	<p>A single combustion air opening can be used for cases b, c or d above, sized as listed, provided that:</p> <ul style="list-style-type: none"> • The single opening must communicate directly to the outdoors or to a space that communicates directly with outdoors (NOT to an interior space). • The top of the opening must be within 12 inches of the ceiling. • The free area of the opening must be at least equal to the sum of the areas of all equipment vent connectors in the space. 	
<p>SPECIAL EXCEPTION FOR LARGE SPACES:</p>	<p>NO combustion air openings are needed when the boiler (and other appliances) are installed in a space with a volume NO LESS than 50 cubic feet per 1,000 Btuh of all appliances in the space. That is, total the input of all appliances in MBH (1,000's of Btuh), then multiply this total times 50. The building MUST NOT be of tight construction.</p> <p>Example: For a total input of 1500 MBH (1,500,000 Btuh) and an 8-foot ceiling height, the minimum volume would be 50 x 1500 x 8 = 60,000 cubic feet.</p>	



DIRECT EXHAUST — Sidewall

Figure 17 DIRECT EXHAUST — Sidewall termination

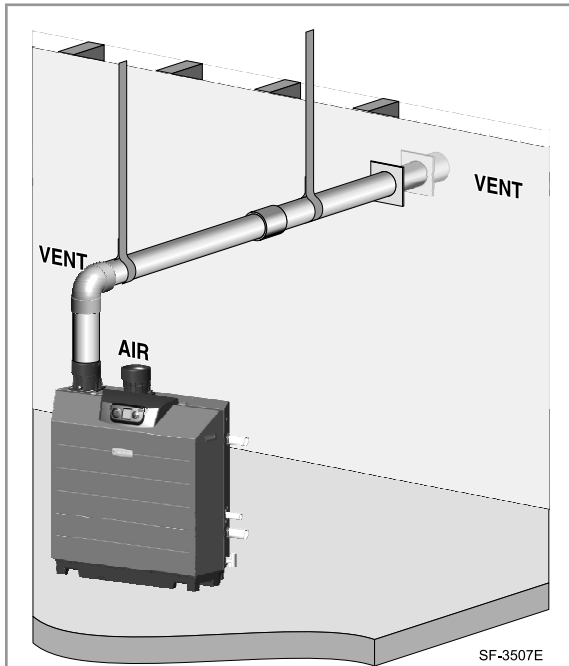

DIRECT EXHAUST — Sidewall termination — installation sequence

⚠ WARNING **Stainless steel pipe** — Install required adapter at each boiler fitting where stainless steel pipe will be connected.

- Step 5** Install the boiler.
- Step 6** Determine the proper location for wall penetration for each termination.
 - Prepare wall penetrations before installing vent piping.
 - Finish by attaching external pipe and fittings as shown in the termination instructions.
 - Support vertical runs on the outside of the building with brackets as shown in the termination instructions.
- Step 7** Install vent piping from boiler to termination.
 - Install a hanger support within 6 inches of any upturn in the piping.
 - Slope horizontal piping downward toward the boiler at least 1/4 inch per foot.
- Step 8** Connect the vent piping at the boiler per manual instructions.

Allowable vent pipe materials

1. Use only the materials listed in Figure 13, page 23.
2. Install a bird screen in each vent pipe termination (coupling or elbow). Bird screens are supplied with the boiler. Cut to size if necessary to fit vent pipe size used.

Maximum piping length

1. Locate the termination such that the total vent piping from the boiler to the termination will not exceed the maximum length given in Figure 18.
2. Maximum lengths listed in Figure 18 allow for 2 elbows. Additional elbows require a reduction in maximum length as explained in the table notes.

Connecting from termination to boiler

1. Install the terminations as instructed in the following. Then proceed to page 45 to complete the vent piping between the termination and the boiler.

Figure 18 Maximum piping lengths for DIRECT EXHAUST sidewall termination

Boiler	** MAXIMUM piping length for pipe diameter =					
	4-inch *		6-inch *		8-inch	
	Feet	Elbows **	Feet	Elbows **	Feet	Elbows **
	PP, PVC, CPVC, ABS, AL29-4C SS					
SF-550	30	2	100	2	Not allowed	
SF-750	Not allowed		30	2	100	2

* For 4-inch or 6-inch piping, install a pipe reducer directly at the boiler connection, oriented vertically. Install reducer above the required adapter if using stainless steel piping.

** For piping using more than 2 elbows, reduce maximum allowable length by 7 feet for each additional elbow (90° or 45°). **ADD** 14 feet to maximum allowable length if the sidewall termination uses a coupling instead of two elbows.

Determine location for sidewall termination

⚠ WARNING A gas vent extending through an exterior wall shall not terminate adjacent to the wall or below building extensions such as eaves, parapets, balconies or decks, except as otherwise instructed in this manual or local codes. Failure to comply could result in severe personal injury, death or substantial property damage.

Place the vent terminations using the following guidelines.

1. Terminate the vent piping with a coupling as shown in Figure 19, page 32. The coupling must butt against the outside wall plate. If vent piping is extended outside, install a coupling at the outer plate and continue vent piping from the coupling (or elbow when snorkeling as in Figure 19, page 32 right side).
 - a. Apply the configuration on the left side of Figure 19, page 32 unless the termination would fail to meet minimum clearance to grade or snow line.
 - b. Apply the configuration on the right side of Figure 19, page 32 when the termination needs to be raised higher to meet clearance to grade or snow line.

DIRECT EXHAUST — Sidewall *(continued)*

- c. The vent pipe may run up as high as 4 feet, as shown in Figure 19 right side, with no enclosure. The vent pipe must be secured with braces, and maintain all required clearances.
- d. Space braces no further than 24 inches apart. (See WARNING below for extremely cold climates.)
- e. External venting greater than 4 feet requires an enclosure around the vent pipe. The vent termination must exit through the enclosure as shown in Figure 19, maintaining all required clearances.

WARNING

Do not exceed the maximum length of the outside vent piping shown in Figure 19. Excessive length exposed to the outside could cause freezing of condensate in the vent pipe, resulting in potential boiler shutdown. In extremely cold climates, install an insulated chase around the vent piping, particularly when using longer lengths. The chase must allow for inspection of the vent pipe, and insulation must be protected from water.

Figure 19 DIRECT EXHAUST — Sidewall — configuration options and minimum clearances

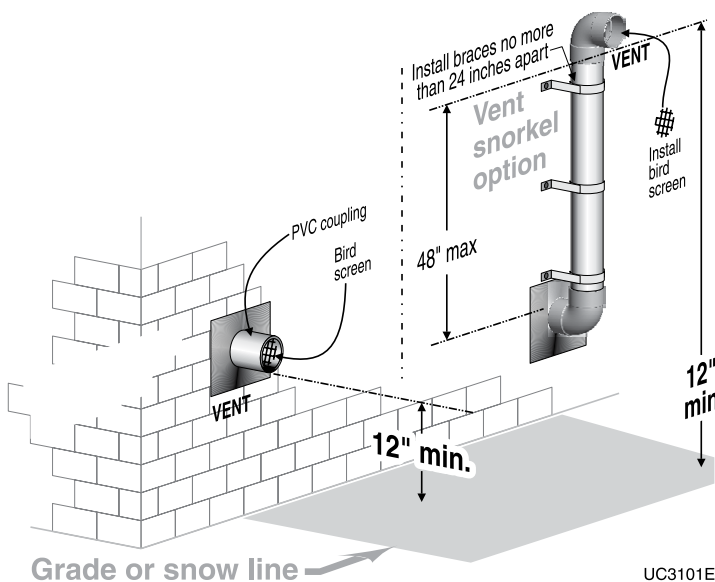

2. Consider the surroundings when terminating the vent:
 - a. Position the vent termination where vapors will not damage nearby shrubs, plants or air conditioning equipment or be objectionable.
 - b. The flue products will form a noticeable plume as they condense in cold air. Avoid areas where the plume could obstruct window views.
 - c. Prevailing winds could cause freezing of condensate and water/ice buildup where flue products impinge on building surfaces or plants.
 - d. Avoid possibility of accidental contact of flue products with people or pets.
 - e. Do not locate the terminations where wind eddies could affect performance, such as inside building corners, near adjacent buildings or surfaces, window wells, stairwells, alcoves, courtyards or other recessed areas.

Figure 20 DIRECT EXHAUST — Sidewall — clearances to openings

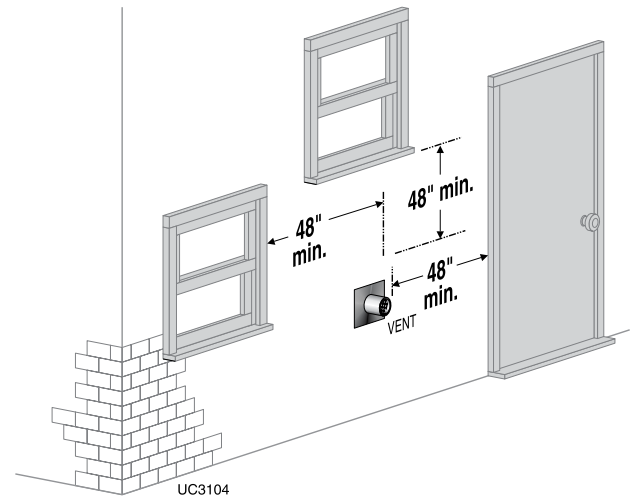
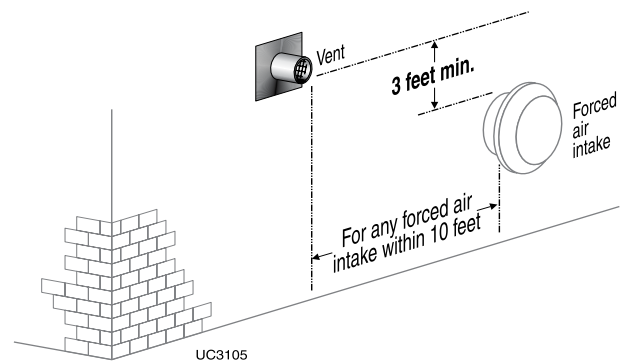

Figure 21 DIRECT EXHAUST — Sidewall — clearances from vent exit to forced air intake



- f. Do not terminate above any door or window or under a deck. Condensate can freeze, causing ice formations.
- g. Locate or guard vent to prevent condensate damage to exterior finishes.
3. Maintain clearances as shown in the illustrations in this manual section. Also maintain the following:
 - a. Vent must terminate:
 - At least 6 feet from adjacent walls.
 - No closer than 5 feet below roof overhang.
 - At least 3 feet above any forced air intake within 10 feet.

DIRECT EXHAUST — Sidewall *(continued)*

- No closer than 48 inches below or horizontally from any door or window or any other gravity air inlet.
 - b. Do not terminate closer than 4 feet horizontally from any electric meter, gas meter, regulator, relief valve or other equipment.
4. Because the SF-550 and SF-750 are Category IV appliances, the National Fuel Gas Code, ANSI Z223.1, requires that the vent must not terminate over a public walkway or over an area where condensate or vapor could create a nuisance or hazard, or could be detrimental to the operation of regulators, relief valves, or other equipment.
 5. Where the vent penetrates an outside wall, the annular space around the penetration must be permanently sealed using approved materials to prevent entry of combustion products into the building.
 6. Locate termination so it is not likely to be damaged by foreign objects, such as stones or balls, or subject to buildup of leaves or sediment.
 7. Do not connect any other appliance to the vent pipe. Do not connect multiple boilers to a common vent pipe.

Completing the vent piping

1. Install vent penetrations as explained in the following pages before installing vent piping from the boiler to the terminations.
2. Insert piping from boiler vent connections, then attach exterior termination piping.
3. Follow instructions beginning on [page 45](#) to complete piping from boiler to termination.

Multiple vent terminations

When terminating multiple direct exhaust SlimFit boilers, terminate each vent connection as described in this manual for individual vents. Space terminations as required for best installation practices and required maintenance.

Prepare wall penetrations

1. Vent pipe penetration:
 - a. Cut a hole for the vent pipe. For either combustible or non-combustible construction, size the vent pipe hole at least 0.4" larger than the vent pipe diameter:
 - 7" hole for 6" PP and PVC
 - 9" hole for 8" PP and PVC
 - b. Insert a galvanized metal thimble in the vent pipe hole as shown in [Figure 35, page 41](#).
2. Use metal cover plates at wall penetrations.
3. Follow all local codes for isolation of vent pipe when passing through floors or walls.
4. Seal exterior openings thoroughly with exterior caulk.

Figure 22 DIRECT EXHAUST — Sidewall — termination assembly — all parts by installer

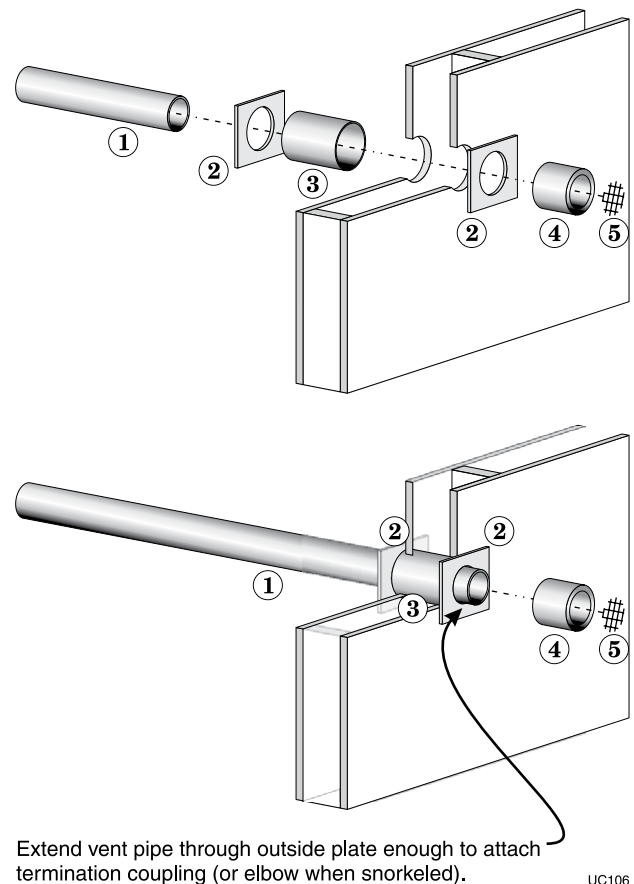

Extend vent pipe through outside plate enough to attach termination coupling (or elbow when snorkeled).

UC106

1 Vent piping	4 Vent elbow
2 Cover plates	5 Bird screen
3 Galvanized thimble	

Termination and fittings

1. Prepare the vent termination elbow ([Figure 19, page 32](#)) by inserting a bird screen. Bird screens are supplied with the boiler, and may have to be trimmed to size for smaller vents.
2. You can install the vent termination using either of the configurations shown in [Figure 19, page 32](#).
3. Maintain the required dimensions of the finished termination piping as shown in [Figure 19, page 32](#).
4. Do not extend exposed vent pipe outside of the building more than shown in this document. Condensate could freeze and block vent pipe.

DIRECT EXHAUST — Vertical

Figure 23 DIRECT EXHAUST vertical termination

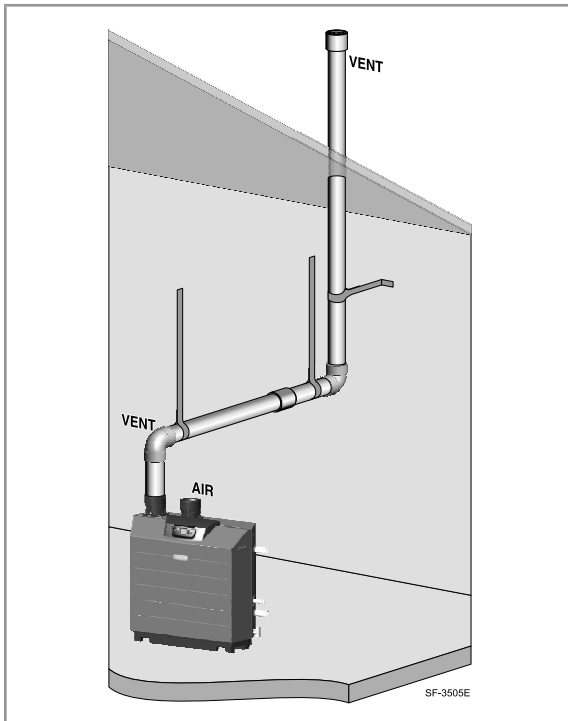

DIRECT EXHAUST — Vertical termination — installation sequence

⚠ WARNING **Stainless steel pipe** — Install required adapter at each boiler fitting where stainless steel pipe will be connected.

Step 1 Install the boiler.

Step 2 Determine the proper location for wall penetration for each termination.

- Prepare roof penetrations before installing vent piping.
- Finish by attaching external pipe and fittings as shown in the termination instructions.
- Install terminations as described in this manual.
- Support vertical runs on the outside of the building with brackets as shown in the termination instructions.

Step 3 Install vent piping from boiler to termination.

- Install a hanger support within 6 inches of any upturn in the piping.
- Slope horizontal piping downward toward the boiler at least 1/4 inch per foot.

Step 4 Connect the vent piping at the boiler per manual instructions.

Allowable vent pipe materials

1. Use only the materials listed in [Figure 13, page 23](#).
2. Install a bird screen in each vent termination (coupling or elbow). Bird screens are supplied with the boiler. Cut to size if necessary to fit vent pipe size used.

Maximum piping length

1. Locate the terminations such that the total vent piping from the boiler to the termination will not exceed the maximum length given in [Figure 24](#).
2. Maximum lengths listed in [Figure 24](#) allow for 2 elbows. Additional elbows require a reduction in maximum length as explained in the table notes.

Connecting from termination to boiler

Install the termination as instructed in the following. Then proceed to [page 45](#) to complete the vent piping between the termination and the boiler.

Figure 24 Maximum piping lengths for DIRECT EXHAUST vertical termination

Boiler	** MAXIMUM piping length for pipe diameter =					
	4-inch *		6-inch *		8-inch	
	Feet	Elbows **	Feet	Elbows **	Feet	Elbows **
	PP, PVC, CPVC, ABS, AL29-4C SS					
SF-550	30	2	100	2	Not allowed	
SF-750	Not allowed		30	2	100	2

* For 4-inch or 6-inch piping, install a pipe reducer directly at the boiler connection, oriented vertically. Install reducer above the required adapter if using stainless steel piping.

** For piping using more than 2 elbows, reduce maximum allowable length by 7 feet for each additional elbow (90° or 45°).

Determine location for vertical termination

1. Locate the vent termination using the following guidelines:
2. The vent piping must terminate in a coupling as shown in [Figure 25, page 35](#).
3. Consider the surroundings when terminating the vent:
 - a. Position the vent termination where vapors will not damage nearby shrubs, plants or air conditioning equipment or be objectionable.
 - b. The flue products will form a noticeable plume as they condense in cold air. Avoid areas where the plume could obstruct window views.
 - c. Prevailing winds could cause freezing of condensate and water/ice buildup where flue products impinge on building surfaces or plants.
 - d. Avoid possibility of accidental contact of flue products with people or pets.
 - e. Do not locate the termination where wind eddies could affect performance or cause recirculation, such as inside building corners, near adjacent buildings or surfaces, window wells, stairwells, alcoves, courtyards or other recessed areas.
 - f. Locate or guard vent to prevent condensate damage to exterior finishes.

DIRECT EXHAUST — Vertical *(continued)*

4. Maintain clearances as shown in the illustrations in this manual section. Also maintain the following:
 - a. Vent must terminate:
 - At least 12 inches above roof or snow line as shown in Figure 25.
 - At least 6 feet from adjacent walls.
 - No closer than 5 feet below roof overhang.
 - At least 3 feet above any forced air intake within 10 feet.
 - No closer than 48 inches below or horizontally from any door or window or any other gravity air inlet.
 - b. Do not terminate closer than 4 feet horizontally from any electric meter, gas meter, regulator, relief valve or other equipment.
5. Where the vent penetrates the roof, the annular space around the penetration must be permanently sealed using approved materials to prevent entry of combustion products into the building.
6. Locate terminations so they are not likely to be damaged by foreign objects, such as stones or balls, or subject to buildup of leaves or sediment.
7. Do not connect any other appliance to the vent pipe. Do not connect multiple boilers to a common vent pipe.

Prepare roof penetrations

1. Vent pipe penetration:
 - a. Cut a hole for the vent pipe. For either combustible or non-combustible construction, size the vent pipe hole at least 0.5" larger than the vent pipe diameter:
 - 7" hole for 6" PP and PVC.
 - 9" hole for 8" PP and PVC.
 - b. Insert a galvanized metal thimble in the vent pipe hole.
2. Follow all local codes for isolation of vent pipe when passing through floors, ceilings and roofs.
3. Provide flashing and sealing boots sized for the vent pipe and air pipe.

Termination and fittings

1. Prepare the vent termination coupling (Figure 25) by inserting a bird screen. Bird screens are supplied with the boiler. Cut to size if necessary to fit vent pipe size used.

Figure 25 DIRECT EXHAUST — Vertical termination

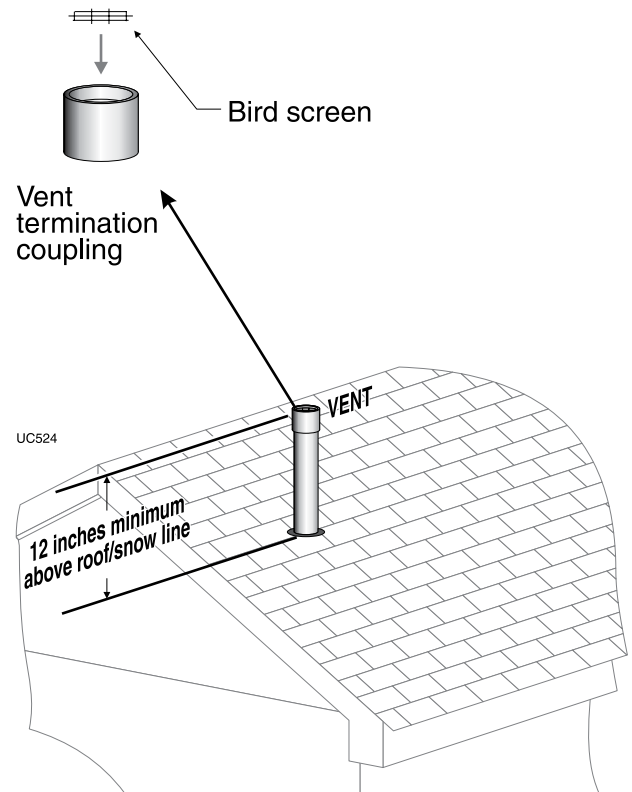

2. The vent piping must terminate in a coupling as shown in Figure 25.
3. Maintain the required dimensions of the finished termination piping as shown in Figure 25.
4. Do not extend exposed vent pipe outside of building more than shown in this document. Condensate could freeze and block vent pipe.

Multiple vent terminations

1. When terminating multiple SlimFit boilers, terminate each vent connection as described in this section. Space terminations as required for best installation practices and required maintenance.

DIRECT VENT — Boiler room air openings

Combustion/ventilation air provision

For direct vent installations, combustion air must be ducted directly from outside to the SlimFit boiler air intake fitting. Two options are available: sidewall or vertical direct vent. Though combustion air is ducted to the SlimFit boiler, the boiler room will still require air openings, either for ventilation or for combustion air for other appliances plus ventilation.

Sizing air openings

Air openings provide for ventilation (as well as combustion air) to prevent overheating of the boiler controls and boiler space. Air is also needed for other appliances located in the same space.

Use [Figure 27, page 37](#), selecting the appropriate installation conditions.

⚠ WARNING Air openings must be sized to handle all appliances and air movers (exhaust fans, etc.) using the air supply.

The sizing given in [Figure 27, page 37](#) is based on the National Fuel Gas Code, ANSI Z223.1, allowing adequate air opening for gravity-vented gas appliances (Category I) when located in the same space as the SlimFit boiler.

When outside air is ducted as directed in this manual, the SlimFit boiler is rated as direct vent (pressurized vent), and has varying requirements for combustion and ventilation air, reflected by the special sizing instructions given in [Figure 27, page 37](#).

The air openings recommended in [Figure 27, page 37](#) will allow adequate ventilation and combustion air provided the boiler room is not subjected to negative pressure due to exhaust fans or other mechanical ventilation devices. Refer to the National Fuel Gas Code for dealing with other conditions.

Louver allowance

The free area of openings means the area after reduction for any installed louvers or grilles. Be sure to consider this reduction when sizing the air openings.

Special considerations

Tight construction

ANSI Z223.1 defines unusually tight construction where:

1. Walls and ceilings exposed to the outside atmosphere have a continuous water vapor retarder with a rating of 1 perm or less with openings gasketed, and . . .
2. Weather-stripping has been added on openable windows and doors, and . . .
3. Caulking or sealants are applied to areas such as joints around windows and door frames, between sole plates and floors, between wall-ceiling joints, between wall panels, at penetrations for plumbing, electrical, and gas lines, and in other openings.

For buildings with such construction, provide air openings into the building from outside, sized per the appropriate case in [Figure 27, page 37](#) if appliances are to use inside air for combustion and ventilation.

Exhaust fans and air movers

The appliance space must never be under a negative pressure unless all appliances are installed as direct vent. Always provide air openings sized not only to the dimensions required for the firing rate of all appliances, but also to handle the air movement rate of the exhaust fans or air movers using air from the building or space.

Motorized air dampers

If the air openings are fitted with motorized dampers, electrically interlock the damper to:

- Prevent the boiler from firing if the damper is not fully open.
- Shut the boiler down should the damper close during boiler operation.

To accomplish this interlock, wire an isolated contact (proving the damper open) in series with the thermostat input to the boiler. The boiler will not start if this contact is open, and will shut down should it open during operation.

Manifolded combustion air option

Multiple SlimFit boilers can use a common combustion air manifold.

- a. See [Figure 104, page 122](#) for minimum cross sectional area of combined air ducts.
- b. Provide minimum clearance to adjacent vents and grade/snow line as shown in [Figure 26](#).
- c. Provide minimum free area in duct (adjusted for louver restriction) of **1 square inch per 2,000 Btuh** total boiler input, or divide the total MBH (1000's Btuh) by 2.
- d. Example: For an MBS system with total input of 3,000,000 Btuh, or 3,000 MBH: Divide 3,000 by 2 = 1500 square inches minimum for a combined air duct.
- e. If combustion air damper is used, wire to boilers to prevent operation except after damper has opened (see Motorized air dampers, above).

⚠ WARNING ONLY air piping can be combined. DO NOT use combined vent piping. Flue gas leakage and boiler component damage can occur. Failure to comply could result in severe personal injury, death or substantial property damage.

Figure 26 Manifolded combustion air option

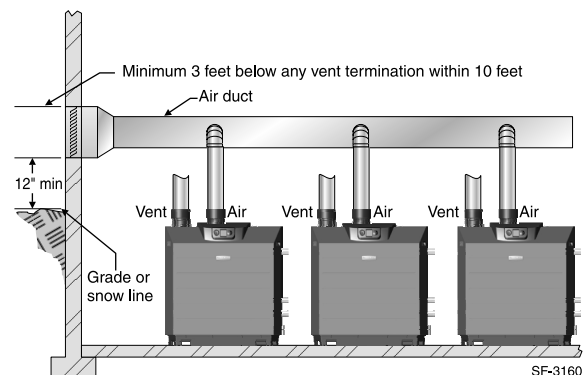



DIRECT VENT — Boiler room air openings *(continued)*

Figure 27 MINIMUM combustion air openings for direct vent applications — ALL OPENING SIZES ARE FREE AREA.
Provisions for combustion and ventilation air to be in accordance with the section “Air for Combustion and Ventilation,” of the National Fuel Gas Code, ANSI Z223.1/NFPA 54, or applicable provisions of the local building codes.

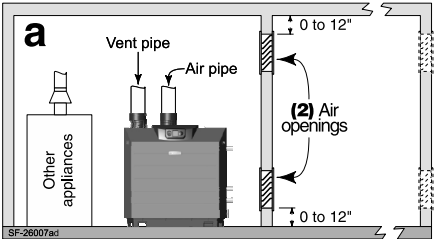
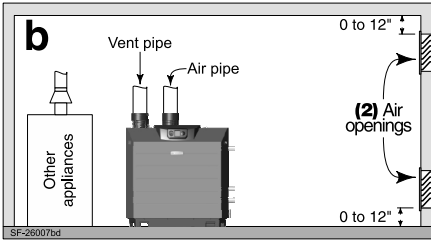
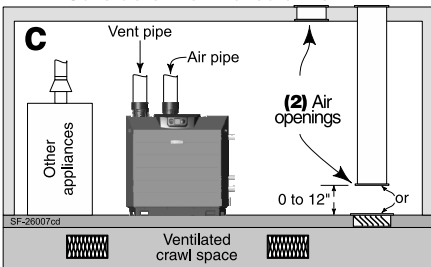
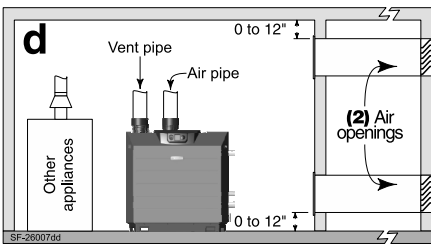
<p style="text-align: center;">Air openings</p> <p>The required air opening sizes below are FREE AREA, after reduction for louver obstruction. Note the exception below for large spaces.</p>	<p style="text-align: center;">SlimFit boiler WITH other appliances in room</p>	<p style="text-align: center;">SlimFit boiler WITHOUT other appliances in room</p>
	<p>TWO openings, each at least: 1 square inch per 1,000 Btuh of all other appliances in the room</p>	<p>NO openings are required if the boiler installation provides at least the Recommended service clearances shown on page 6.</p> <p>If the space is smaller, provide ONE opening to a larger room with at least 1 square inch per 3,000 Btuh of SlimFit boiler input.</p>
	<p>TWO openings, each at least: 1 square inch per 4,000 Btuh of all other appliances in the room — OR — ONE opening **, each at least: 1 square inch per 3,000 Btuh of all other appliances in the room</p>	<p>NO openings are required if the boiler installation provides at least the Recommended service clearances shown on page 6.</p> <p>If the space is smaller, provide ONE opening to a larger room with at least 1 square inch per 3,000 Btuh of SlimFit boiler input.</p>
<p style="text-align: center;">Outside or ventilated attic</p> 	<p>TWO openings, each at least: 1 square inch per 2,000 Btuh of all other appliances in the room — OR — ONE opening **, each at least: 1 square inch per 3,000 Btuh of all other appliances in the room</p>	<p>NO openings are required if the boiler installation provides at least the Recommended service clearances shown on page 6.</p> <p>If the space is smaller, provide ONE opening to a larger room with at least 1 square inch per 3,000 Btuh of SlimFit boiler input.</p>
	<p>TWO openings, each at least: 1 square inch per 4,000 Btuh of all other appliances in the room — OR — ONE opening **, each at least: 1 square inch per 3,000 Btuh of all other appliances in the room</p>	<p>NO openings are required if the boiler installation provides at least the Recommended service clearances shown on page 6.</p> <p>If the space is smaller, provide ONE opening to a larger room with at least 1 square inch per 3,000 Btuh of SlimFit boiler input.</p>
<p>** NOTICE: Requirements for using the SINGLE air opening option.</p>	<p>A single combustion air opening can be used for cases b, c or d above, sized as listed, provided that:</p> <ul style="list-style-type: none"> The single opening must communicate directly to the outdoors or to a space that communicates directly with outdoors (NOT to an interior space). The top of the opening must be within 12 inches of the ceiling. The free area of the opening must be at least equal to the sum of the areas of all equipment vent connectors in the space. 	
<p>SPECIAL EXCEPTION FOR LARGE SPACES:</p>	<p>NO combustion air openings are needed when the boiler (and other appliances) are installed in a space with a volume NO LESS than 50 cubic feet per 1,000 Btuh of all appliances in the space. That is, total the input of all appliances in MBH (1,000's of Btuh), then multiply this total times 50. The building MUST NOT be of tight construction.</p> <p>Example: For a total input of 1500 MBH (1,500,000 Btuh) and an 8-foot ceiling height, the minimum volume would be 50 x 1500 x 8 = 60,000 cubic feet.</p>	



DIRECT VENT — Sidewall

Figure 28 DIRECT VENT sidewall termination

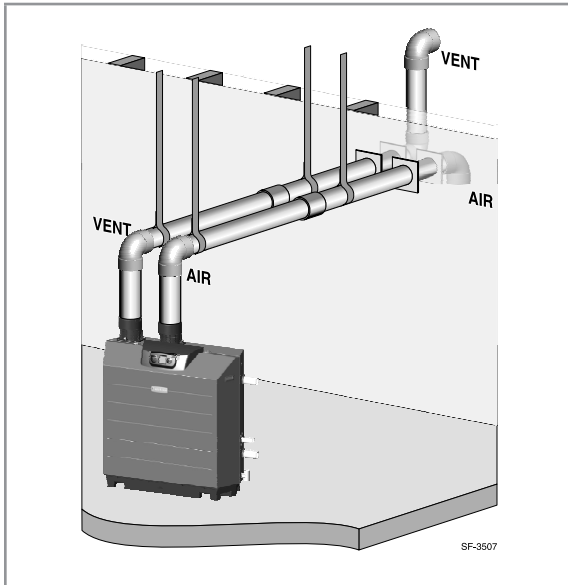

DIRECT VENT — Sidewall termination with separate vent and air pipes — installation sequence

WARNING **Stainless steel pipe** — Install required adapter at each boiler fitting where stainless steel pipe will be connected.

Step 1 Install the boiler.

Step 2 Determine the proper location for wall penetration for each termination.

- Prepare wall penetrations before installing vent and air piping.
- Finish by attaching external pipe and fittings as shown in the termination instructions.
- Install termination assembly as described in this manual.
- Support vertical runs on the outside of the building with brackets as shown in the termination instructions.

Step 3 Install air and vent piping from boiler to termination.

- Install a hanger support within 6 inches of any upturn in the piping.
- Slope horizontal piping downward toward the boiler at least 1/4 inch per foot.

Step 4 Connect the vent and air piping at the boiler per manual instructions.

Allowable vent/air pipe materials

1. Use only the materials listed in Figure 13, page 23.
2. Install a bird screen in each vent and air pipe termination. Bird screens are supplied with the boiler. Cut to size if necessary to fit vent pipe size used.

Maximum piping length

1. Locate the terminations such that the total air piping and vent piping from the boiler to the termination will not exceed the maximum length given in Figure 29.
2. Maximum lengths listed in Figure 29 allow for 2 elbows. Additional elbows require a reduction in maximum length as explained in the table notes.

Connecting from termination to boiler

Install the terminations as instructed in the following. Then proceed to page 45 to complete the air and vent piping between the termination and the boiler.

Figure 29 Maximum piping lengths for DIRECT VENT sidewall termination

Boiler	** MAXIMUM piping length for pipe diameter =					
	4-inch *		6-inch *		8-inch	
	PP, PVC, CPVC, ABS, AL29-4C SS					
	Feet	Elbows **	Feet	Elbows **	Feet	Elbows **
SF-550	30	2	100	2	Not allowed	
SF-750	Not allowed		30	2	100	2

* For 4-inch or 6-inch piping, install a pipe reducer directly at the boiler connection, oriented vertically. Install reducer above the required adapter if using stainless steel piping.

** For piping using more than 2 elbows, reduce maximum allowable length by 7 feet for each additional elbow (90° or 45°).

Determine location for termination

WARNING A gas vent extending through an exterior wall shall not terminate adjacent to the wall or below building extensions such as eaves, parapets, balconies or decks, except as otherwise instructed in this manual or local codes. Failure to comply could result in severe personal injury, death or substantial property damage.

1. Place the vent/air terminations using the following guidelines.
2. The vent and air piping must terminate as shown in Figure 30, page 39. (The elbow at the exit opening must butt against the outside wall plate.) This arrangement avoids recirculation of flue products into the combustion air stream.
 - a. Apply the configuration on the left side of Figure 30, page 39 unless the terminations would fail to meet minimum clearance to grade or snow line.



DIRECT VENT — Sidewall *(continued)*

- b. Apply the configuration on the right side of Figure 30 when the terminations need to be raised higher to meet clearance to grade or snow line.
 - c. The vent and air pipes may run up as high as 4 feet, as shown in Figure 30 right side with no enclosure. The vent and air pipes must be secured with braces, and all clearances and lengths must be maintained. Space braces no further than 24 inches apart. (See WARNING below for extremely cold climates.)
 - d. External venting greater than 4 feet requires an enclosure around the vent and air pipes. The vent and air terminations must exit through the enclosure as shown in Figure 30, maintaining all required clearances.
3. The vent piping must terminate in an elbow pointed outward or away from the building, as shown in Figure 30.

WARNING Do not exceed the maximum lengths of the outside vent piping shown in Figure 30. Excessive length exposed to the outside could cause freezing of condensate in the vent pipe, resulting in potential boiler shutdown. In extremely cold climates, install an insulated chase around the vent piping, particularly when using longer lengths. The chase must allow for inspection of the vent pipe, and insulation must be protected from water.

Figure 30 DIRECT VENT — Sidewall — configuration options and minimum clearances from vent to air terminations

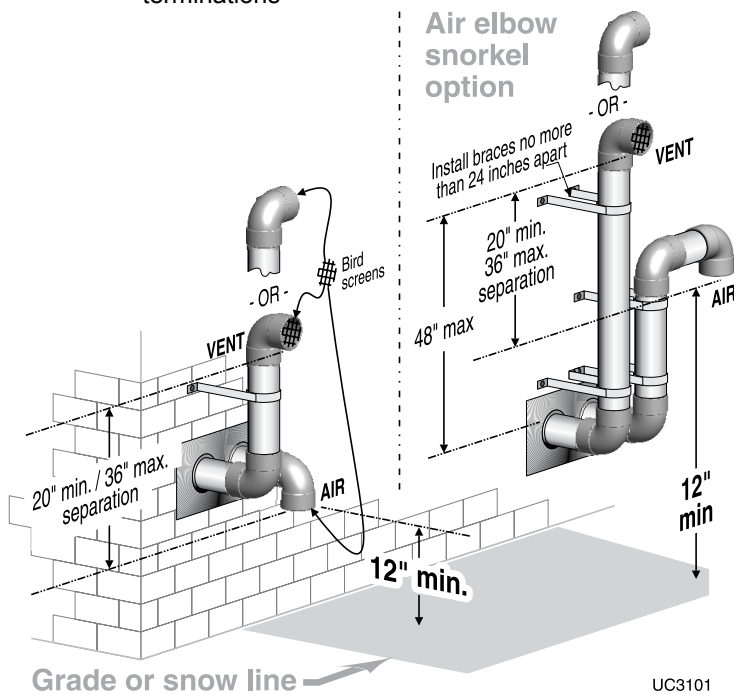

4. Consider the surroundings when terminating the vent and air:
 - a. Position the vent termination where vapors will not damage nearby shrubs, plants or air conditioning equipment or be objectionable.
 - b. The flue products will form a noticeable plume as they condense in cold air. Avoid areas where the plume could obstruct window views.
 - c. Prevailing winds could cause freezing of condensate and water/ice buildup where flue products impinge on building surfaces or plants.

Figure 31 Sidewall termination with separate pipes — clearances to openings

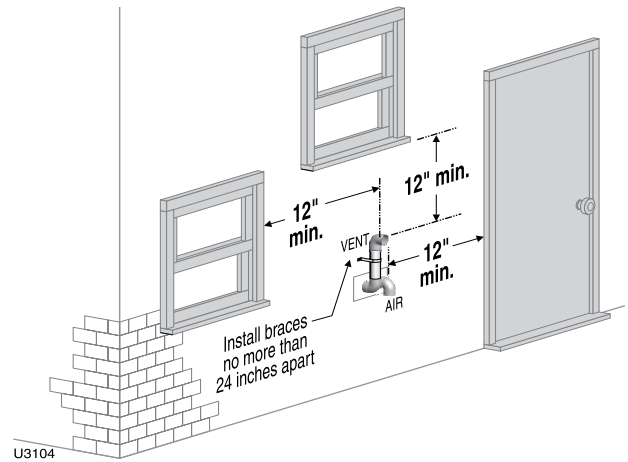
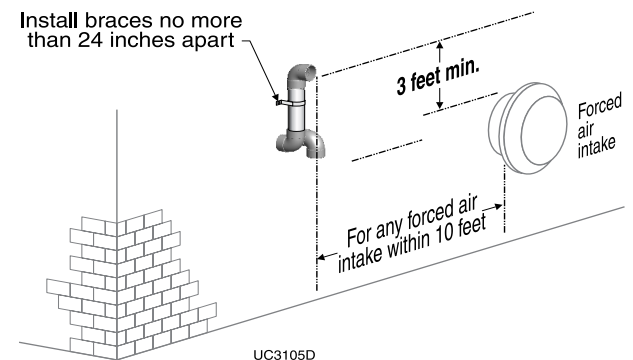

Figure 32 Sidewall termination with separate pipes — clearances from vent exit to forced air intake



CAUTION Terminating with the vent elbow sideways instead of pointed away from the building can result in the possibility of ice build-up on the side of the building.

NOTICE If the vent/air pipes are extended out beyond the wall, install a coupling at the exit opening, with the coupling butted against the outside plate. Then continue vent/air piping from the coupling.

DIRECT VENT — Sidewall *(continued)*

- d. Avoid possibility of accidental contact of flue products with people or pets.
 - e. Do not locate the terminations where wind eddies could affect performance or cause recirculation, such as inside building corners, near adjacent buildings or surfaces, window wells, stairwells, alcoves, courtyards or other recessed areas.
 - f. Do not terminate above any door or window or under a deck. Condensate can freeze, causing ice formations.
 - g. Locate or guard vent to prevent condensate damage to exterior finishes.
5. Maintain clearances as shown in the illustrations in this manual section. Also maintain the following:
 - a. Vent must terminate:
 - At least 6 feet from adjacent walls.
 - No closer than 5 feet below roof overhang.
 - At least 3 feet above any forced air intake within 10 feet.
 - b. Do not terminate closer than 4 feet horizontally from any electric meter, gas meter, regulator, relief valve or other equipment.
 6. Because the SF-550 and SF-750 are condensing appliances, the National Fuel Gas Code, ANSI Z223.1, requires that the vent must not terminate over a public walkway or over an area where condensate or vapor could create a nuisance or hazard, or could be detrimental to the operation of regulators, relief valves, or other equipment.
 7. Where the vent or air pipe penetrates an outside wall, the annular space around the penetration must be permanently sealed using approved materials to prevent entry of combustion products into the building.
 8. Locate terminations so they are not likely to be damaged by foreign objects, such as stones or balls, or subject to buildup of leaves or sediment.
 9. Do not connect any other appliance to the vent pipe or multiple boilers to a common vent pipe.

Completing the vent/air piping

1. Install vent/air penetrations as explained in the following pages before installing vent and air piping from the boiler to the terminations. Insert piping from boiler air and vent connections, then attach exterior termination piping.
2. Follow instructions beginning on [page 45](#) to complete piping from boiler to termination.

Multiple vent/air terminations

1. When terminating multiple SlimFit boilers, terminate each vent/air connection as described in this manual.

- WARNING** All vent pipes and air inlets must terminate at the same height to avoid possibility of severe personal injury, death or substantial property damage.
2. Place wall penetrations to obtain minimum clearance of 12 inches between vent pipe and adjacent air inlet elbow, as shown in Figure 33 for U. S. installations.
 3. For Canadian installations, provide clearances required by CSA B149.1 or B149.2 Installation Code.
 4. The air inlet of an SlimFit boiler is part of a direct vent connection. It is not classified as a forced air intake with regard to spacing from adjacent boiler vents.
 5. Combustion air (NOT vent piping) can be manifolded as shown in [Figure 26, page 36](#).

Figure 33 Multiple terminations — separate pipes — clearance from vent of one to air intake of the next

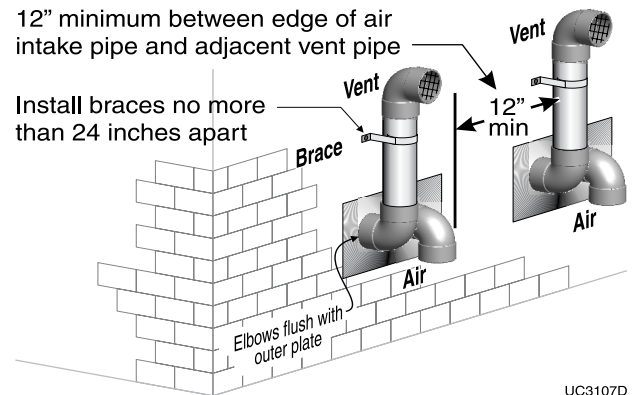

UC3107D

Figure 34 Multiple terminations — separate pipes — clearance from vent of one to air intake of the next — alternate configuration of air and vent terminations

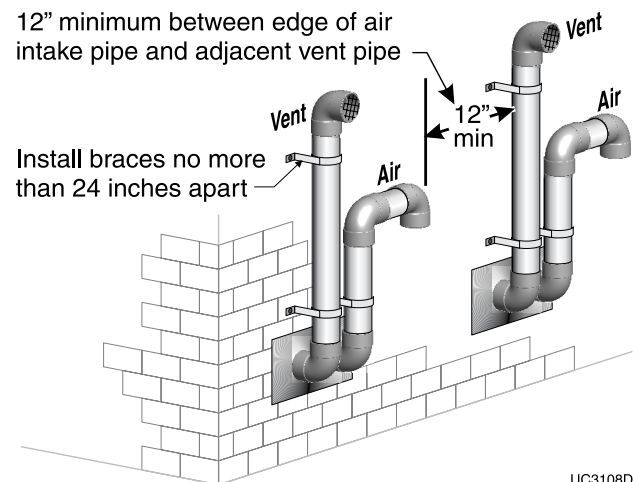

UC3108D

NOTICE If the vent/air pipes are extended out beyond the wall, install a coupling at the exit opening, with the coupling butted against the outside plate. Then continue vent/air piping from the coupling.



DIRECT VENT — Sidewall *(continued)*

Prepare wall penetrations

1. Air pipe penetration:
 - a. Cut a hole for the air pipe. Size the air pipe hole as close as desired to the air pipe outside diameter.
2. Vent pipe penetration:
 - a. Cut a hole for the vent pipe. For either combustible or non-combustible construction, size the vent pipe hole at least 0.4" larger than the vent pipe diameter:
 - 7" hole for 6" PP and PVC
 - 9" hole for 8" PP and PVC
 - b. Insert a galvanized metal thimble in the vent pipe hole as shown in Figure 35.
3. Sidewall termination plates must be provided by the installer.
4. Follow all local codes for isolation of vent pipe when passing through floors or walls.
5. Seal exterior openings thoroughly with exterior caulk.

Termination and fittings

1. Prepare the vent termination elbow and the air termination elbow (Figure 35) by inserting a bird screen in each. Bird screens are supplied with the boiler. Cut to size if necessary to fit vent pipe size used.
2. When completed, the air termination elbow must be oriented at least 20 inches (and no more than 36 inches) below the vent termination, and at least 12 inches above grade or snow line as shown in Figure 30, page 39.
3. You can orient the vent termination elbow either directly outward or 90 degrees away from the air inlet elbow as shown in Figure 30, page 39.
4. Maintain the required dimensions of the finished termination piping as shown in Figure 30, page 39.
5. Do not extend exposed vent pipe outside of building more than shown in this document. Condensate could freeze and block vent pipe.

NOTICE If the vent/air pipes are extended out beyond the wall, install a coupling at the exit opening, with the coupling butted against the outside plate. Then continue vent/air piping from the coupling.

WARNING Do not exceed the maximum lengths of the outside vent piping shown in Figure 30, page 39. Excessive length exposed to the outside could cause freezing of condensate in the vent pipe, resulting in potential boiler shutdown. In extremely cold climates, install an insulated chase around the vent piping, particularly when using longer lengths. The chase must allow for inspection of the vent pipe, and insulation must be protected from water.

Figure 35 DIRECT VENT — Sidewall — termination assembly (all parts by installer, except the bird screens)

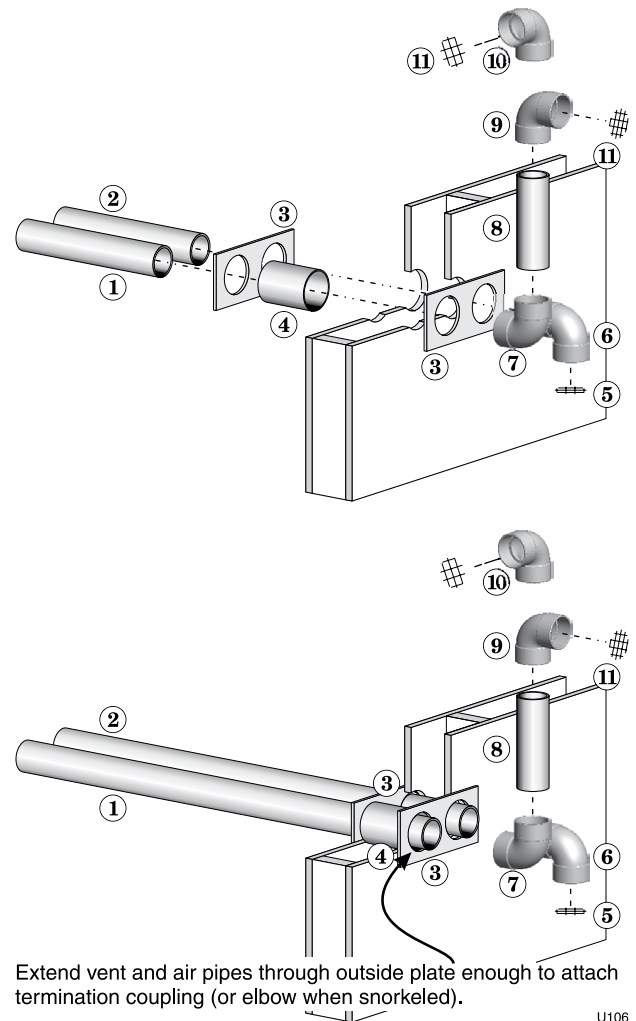

Extend vent and air pipes through outside plate enough to attach termination coupling (or elbow when snorkeled).

U106

1 Vent piping	7 Elbow
2 Air piping	8 Nipple
3 Cover plates	9 Elbow (vent termination)
4 Galvanized thimbles	10 Alternate elbow orientation
5 Bird screen (air)	11 Bird screen (vent termination)
6 Air inlet elbow	

DIRECT VENT — Vertical

Figure 36 DIRECT VENT vertical termination

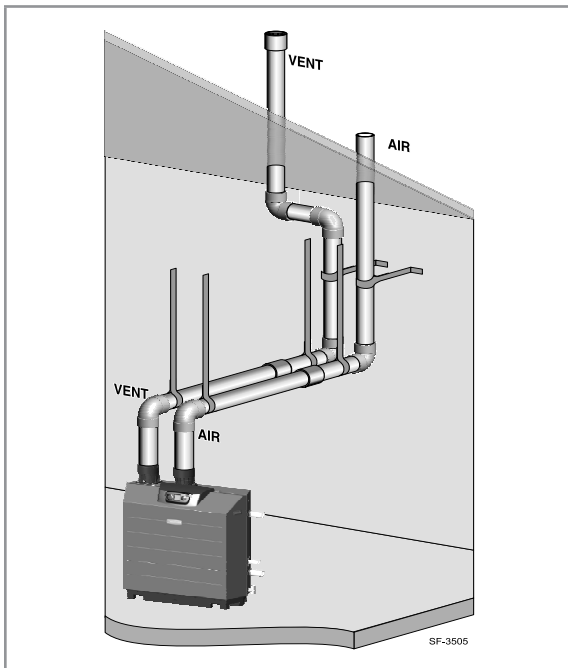

DIRECT VENT — Vertical termination with separate vent and air pipes — installation sequence

⚠ WARNING **Stainless steel pipe** — Install required adapter at each boiler fitting where stainless steel pipe will be connected.

Step 1 Install the boiler.

Step 2 Determine the proper location for wall penetration for each termination.

- Prepare roof penetrations before installing vent and air piping.
- Finish by attaching external pipe and fittings as shown in the termination instructions.
- Install terminations as described in this manual.
- Support vertical runs on the outside of the building with brackets as shown in the termination instructions.

Step 3 Install air and vent piping from boiler to termination.

- Install a hanger support within 6 inches of any upturn in the piping.
- Slope horizontal piping downward toward the boiler at least 1/4 inch per foot.

Step 4 Connect the vent and air piping at the boiler per manual instructions.

Allowable vent/air pipe materials

1. Use only the materials listed in Figure 13, page 23.
2. Install a bird screen in each vent and air pipe termination. Bird screens are supplied with the boiler. Cut to size if necessary to fit vent pipe size used.

Maximum piping length

1. Locate the terminations such that the total air piping and vent piping from the boiler to the termination will not exceed the maximum length given in Figure 37.
2. Maximum lengths listed in Figure 37 allow for 2 elbows. Additional elbows require a reduction in maximum length as explained in the table notes.

Connecting from termination to boiler

Install the terminations as instructed in the following. Then proceed to page 45 to complete the air and vent piping between the termination and the boiler.

Figure 37 Maximum piping lengths for DIRECT VENT vertical termination

Boiler	** MAXIMUM piping length for pipe diameter =					
	4-inch *		6-inch *		8-inch	
	PP, PVC, CPVC, ABS, AL29-4C SS					
	Feet	Elbows **	Feet	Elbows **	Feet	Elbows **
SF-550	30	2	100	2	Not allowed	
SF-750	Not allowed		30	2	100	2

* For 4-inch or 6-inch piping, install a pipe reducer directly at the boiler connection, oriented vertically. Install reducer above the required adapter if using stainless steel piping.

** For piping using more than 2 elbows, reduce maximum allowable length by 7 feet for each additional elbow (90° or 45°).

Determine location for vertical terminations

1. Locate the vent/air terminations using the following guidelines:
2. The air piping must terminate in a down-turned 180-degree return bend as shown in Figure 38, page 43. Locate the air inlet pipe no further than 2 feet from the center of the vent pipe. This placement avoids recirculation of flue products into the combustion air stream.
3. The vent piping must terminate in an up-turned coupling as shown in Figure 38, page 43. The top of the coupling must be at least 1 foot above the air intake. The air inlet pipe and vent pipe can be located in any desired position on the roof, but must always be no further than 2 feet apart and with the vent termination at least 1 foot above the air intake.
4. Consider the surroundings when terminating the vent and air:
 - a. Position the vent termination where vapors will not damage nearby shrubs, plants or air conditioning equipment or be objectionable.

DIRECT VENT — Vertical *(continued)*

- b. The flue products will form a noticeable plume as they condense in cold air. Avoid areas where the plume could obstruct window views.
 - c. Prevailing winds could cause freezing of condensate and water/ice buildup where flue products impinge on building surfaces or plants.
 - d. Avoid possibility of accidental contact of flue products with people or pets.
 - e. Do not locate the terminations where wind eddies could affect performance or cause recirculation, such as inside building corners, near adjacent buildings or surfaces, window wells, stairwells, alcoves, courtyards or other recessed areas.
 - f. Do not terminate above any door or window. Condensate can freeze, causing ice formations.
 - g. Locate or guard vent to prevent condensate damage to exterior finishes.
 - h. Maintain clearances to vent termination as given below:
 - i. Vent must terminate:
 - At least 6 feet from adjacent walls.
 - No closer than 5 feet below roof overhang.
 - At least 3 feet above any forced air intake within 10 feet.
 - No closer than 12 inches below or horizontally from any door or window or any other gravity air inlet.
 - j. Air inlet must terminate at least 12 inches above the roof or snow line and at least 12 inches below the vent termination as shown in Figure 38.
 - k. Do not terminate closer than 4 feet horizontally from any electric meter, gas meter, regulator, relief valve or other equipment.
5. Where the vent or air pipe penetrates the roof, the annular space around the penetration must be permanently sealed using approved materials to prevent entry of combustion products into the building.
 6. Locate terminations so they are not likely to be damaged by foreign objects, such as stones or balls, or subject to buildup of leaves or sediment.
 7. Do not connect any other appliance to the vent pipe or multiple boilers to a common vent pipe.

Prepare roof penetrations

1. Air pipe penetration:
 - a. Cut a hole for the air pipe. Size the air pipe hole as close as desired to the air pipe outside diameter.
2. Vent pipe penetration:
 - a. Cut a hole for the vent pipe. For either combustible or non-combustible construction, size the vent pipe hole at least $\frac{1}{2}$ " larger than the vent pipe diameter:
 - 7" hole for 6" PP and PVC or 9" for 8" PP and PVC.
 - b. Insert a galvanized metal thimble in the vent pipe hole.
3. Space the air and vent holes to provide the minimum spacings shown in Figure 38.
4. Follow all local codes for isolation of vent pipe when passing through floors, ceilings and roofs.
5. Provide flashing and sealing boots sized for the vent pipe and air pipe.

Termination and fittings

1. Prepare the vent termination coupling and the air termination return bend (Figure 38) by inserting a bird screen in each. Bird

Figure 38 Vertical termination — separate pipes

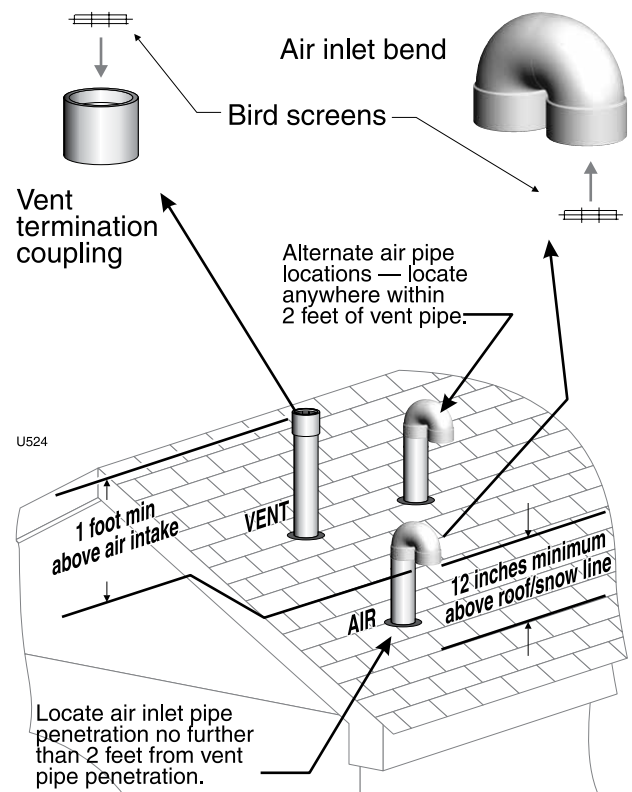

DIRECT VENT — Vertical *(continued)*

screens are supplied with the boiler. Cut to size if necessary to fit vent pipe size used.

2. The air piping must terminate in a down-turned 180-degree return bend as shown in [Figure 38, page 43](#). Locate the air inlet pipe no further than 2 feet from the center of the vent pipe. This placement avoids recirculation of flue products into the combustion air stream.
3. The vent piping must terminate in an up-turned coupling as shown in [Figure 38, page 43](#).
 - a. Vent must terminate:
 - At least 6 feet from adjacent walls.
 - No closer than 5 feet below roof overhang.
 - At least 3 feet above any forced air intake within 10 feet.
 - No closer than 12 inches below or horizontally from any door or window or any other gravity air inlet.
4. The air inlet pipe and vent pipe can be located in any desired position on the roof, but must always be no further than 2 feet apart and with the vent termination at least 1 foot above the air intake.
5. Maintain the required dimensions of the finished termination piping as shown in [Figure 38, page 43](#).
6. Do not extend exposed vent pipe outside of building more than shown in this document. Condensate could freeze and block vent pipe.

Multiple vent/air terminations (Figure 39)

1. When terminating multiple SlimFit boilers, terminate each vent/air connection as described in this section.

- ⚠ WARNING** Terminate all vent pipes at the same height and all air pipes at the same height to avoid possibility of severe personal injury, death or substantial property damage.
2. Place roof penetrations to obtain minimum clearance of 12 inches between edge of air intake elbow and adjacent vent pipe of another boiler for U. S. installations (see [Figure 39](#)). For Canadian installations, provide clearances required by CSA B149.1 or B149.2 Installation Code.
 3. The air inlet of an SlimFit boiler is part of a direct vent connection. It is not classified as a forced air intake with regard to spacing from adjacent boiler vents.

Figure 39 Termination location — separate pipes — terminations for multiple boilers

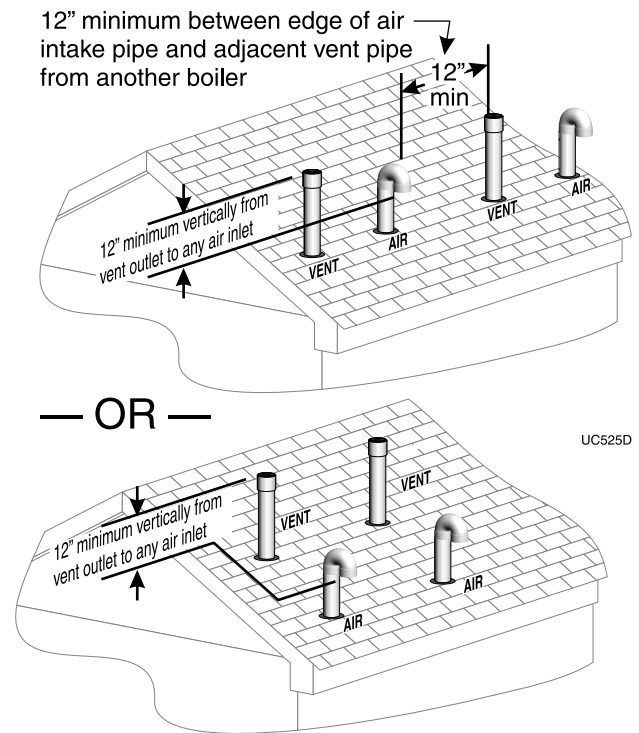

Install vent/air piping — from termination to boiler

Complete termination preparation

Install vent and air terminations before proceeding. See previous pages for instructions.

Pipe joint preparation and sealing

PP, PVC, CPVC or ABS piping

1. Dry assemble entire vent or air piping to ensure proper fit before assembling any joint. Mark pipe with felt-tip pen to ensure full insertion when completing each joint.
2. Cut pipe to required lengths.
3. Deburr inside and outside of pipe ends.
4. Chamfer outside of each pipe end to ensure even cement distribution when joining.
5. Clean all pipe ends and fittings. Dry thoroughly.
6. For each joint:
 - a. Handle fittings and pipes carefully to prevent contamination of surfaces.
 - b. Apply primer liberally to both joint surfaces — pipe end and fitting socket.
 - c. While primer is still damp, lightly apply approved cement to both surfaces in a uniform coating.
 - d. Apply a second coat to both surfaces. Avoid using too much cement on sockets to prevent cement buildup inside.
 - e. With cement still wet, insert pipe into fitting, twisting $\frac{1}{4}$ turn. Make sure pipe is fully inserted.
 - f. Wipe excess cement from joint. Check joint to be sure a smooth bead of cement shows around the entire joint.

CAUTION Use cement sparingly. Excessive cement can cause blockage of the condensate opening.

AL29-4C stainless steel piping

1. Install the required stainless vent adapter at boiler vent connection, following instructions supplied with the adapter.
2. Follow vent pipe manufacturer's instructions for preparing and sealing joints.

Installing vent and air piping

1. For reference in the following see:
 - a. DIRECT EXHAUST — Sidewall terminations: see [Figure 17, page 31](#).
 - b. DIRECT EXHAUST — Vertical terminations: see [Figure 25, page 35](#).
 - c. DIRECT VENT — Sidewall terminations: see [Figure 28, page 38](#).
 - d. DIRECT VENT — Vertical terminations: see [Figure 36, page 42](#).
2. Work from the boiler to vent or air termination. Do not exceed the lengths given in the previous pages for either the air or vent piping.
 - a. As shown in the maximum length tables, the SF-550 must be installed with only 6-inch vent and air piping.
 - b. As shown in the maximum length tables, the SF-750 may be installed with either 6-inch or 8-inch vent and air piping.
 - c. SF-750 only — Install appropriate pipe reducers, when required, at both the boiler vent and air connections. Install directly at the boiler, with reducer in the vertical orientation.
3. See Figure 40 for attaching vent and air pipes at the boiler.

Figure 40 Boiler vent and air connections

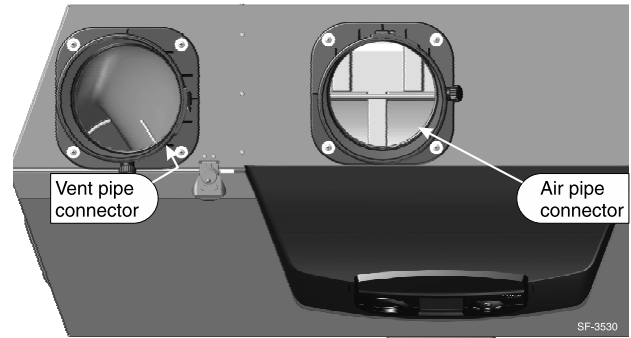

Inserting/securing vent or air pipe into boiler connectors

WARNING **Stainless steel pipe** — Install required adapter at each boiler fitting where stainless steel pipe will be connected.

1. Clean and chamfer insertion end of pipe. Deburr inside of insertion end.
2. Inspect boiler vent or air adapter (above) — verify no obstructions or foreign objects inside.
3. Measure $3\frac{1}{2}$ inches from end of pipe and make a mark with felt-tip pen before assembling joint.
4. Prepare and assemble joints per instructions at left.

WARNING Do not apply excessive force or bend the adapter or flue/air pipe when inserting. The adapter could be damaged.

4. Install pipe supports as shown in [Figure 28, page 38](#) or [Figure 36, page 42](#).
5. Slope vent and air piping continuously toward boiler, with at least $\frac{1}{4}$ inch drop per foot of run. Do not allow sags at any point.
6. Maintain minimum clearance of $\frac{3}{16}$ inch between vent pipe and any combustible wall or material.
7. Seal wall or floor penetration openings following local code requirements.

Install condensate components

Install condensate drain tee

1. See Figure 41.
2. Remove PVC fittings and gasket from the accessories bag.
3. Deburr and chamfer outside and inside of 1" PVC nipple (item 1) to ensure even cement distribution when joining.
4. Clean nipple ends and all fittings. Dry thoroughly.
5. For each joint in the condensate line, apply the following. Assemble parts ONLY in the order given.
 - a. Apply primer liberally to both joint surfaces — pipe end and fitting socket.
 - b. While primer is still damp, lightly apply approved cement to both surfaces in a uniform coating.
 - c. Apply a second coat of cement to both surfaces. Avoid using too much cement on sockets to prevent cement buildup inside.
 - d. With cement still wet, insert pipe into fitting, twisting $\frac{1}{4}$ turn. Make sure pipe is fully inserted.
 - e. Wipe excess cement from joint. Check joint to be sure a smooth bead of cement shows around the entire joint.
6. Assemble the 1" PVC nipple to the PVC condensate drain tee (item 2). Insert the nipple completely into the tee socket.
7. Allow joint to dry completely.
8. Slide the finished nipple/tee assembly into the condensate drain hole.
9. Slide the gasket (item 3) over the nipple.
10. Cement the 1" coupling (item 4) to the protruding 1" nipple. Press together FIRMLY to ensure the gasket is compressed for an air-tight seal. Hold in place long enough for the PVC cement to set.
11. See Figure 42 for completed assembly.

CAUTION Firmly press the coupling and the tee together while the cement sets to ensure the gasket is securely compressed. The gasket ensures the jacket enclosure is airtight at this location.

Figure 41 Condensate drain tee assembly

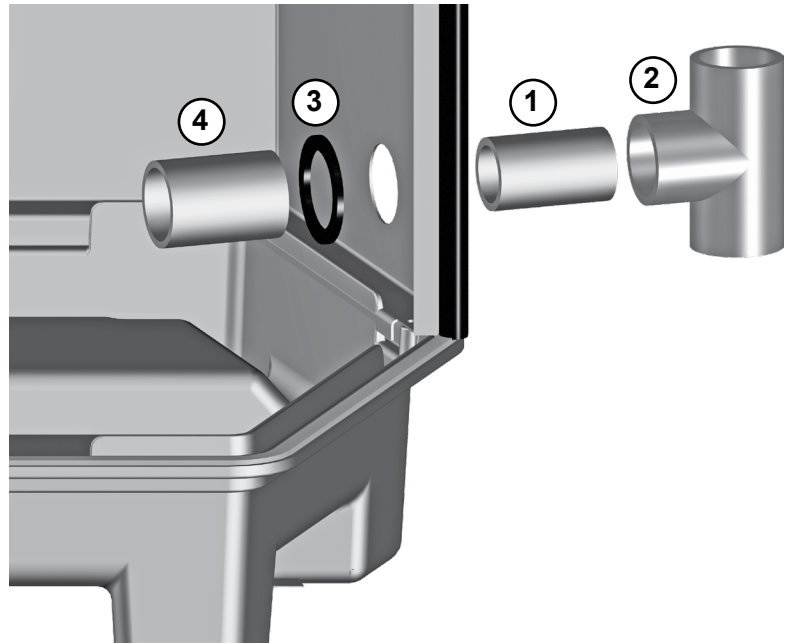
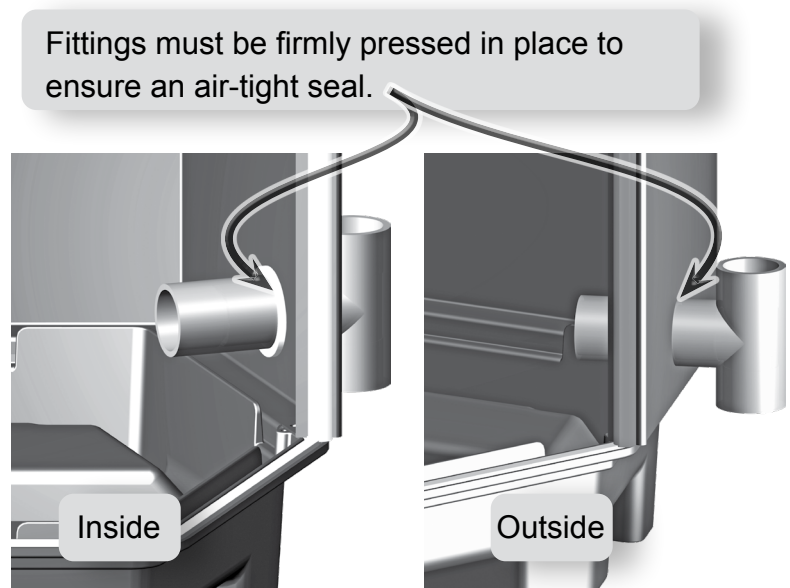

Figure 42 Condensate drain tee, completed





Install condensate components *(continued)*

Connect condensate trap

1. See Figure 44.
2. Remove the protector cap from the bottom of the PVC tee at the heat exchanger condensate connection (location 2).
3. Slide a hose clamp over each end of the condensate trap line.
4. Slide the ends of the line onto the bottom of the PVC tee at the heat exchanger condensate connection (location 2) and onto the PVC coupling on the right (location 1).
5. Slide the hose clamps into position and tighten securely.

Connect condensate line

1. Connect condensate drain tubing to the 1" PVC condensate tee and run to floor drain or condensate pump (see Figure 45). Use 1" PVC or CPVC pipe; or install a hose barb fitting and connect tubing.

NOTICE Use materials approved by the authority having jurisdiction. In the absence of other authority, PVC and CPVC pipe must comply with ASTM D1785, F441 or D2665. Cement and primer must comply with ASTM D2564 or F493. For Canada, use CSA or ULC certified PVC or CPVC pipe, fittings and cement.

2. Leave the top of the 1" tee OPEN. This is needed as a vacuum break.
3. When installing a condensate pump, select one approved for use with condensing boilers and furnaces. The pump should have an overflow switch to prevent property damage from condensate spillage. See Figure 43 for required flow capacity.
4. When sizing condensate pumps, make sure to include the total load of all SlimFit boilers connected to it.

CAUTION The condensate line must remain unobstructed, allowing free flow of condensate. If condensate is allowed to freeze in the line or if the line is obstructed in any other manner, condensate can exit from the boiler tee, resulting in potential water damage to property.

NOTICE Condensate from the SlimFit boiler will be slightly acidic (typically with a pH from 3.2 to 4.5). Install a neutralizing filter if required by local codes. See [Replacement parts, starting on page 108](#) for the Weil-McLain kit.

Figure 44 Condensate trap installed (shown with inlet air silencer hidden)

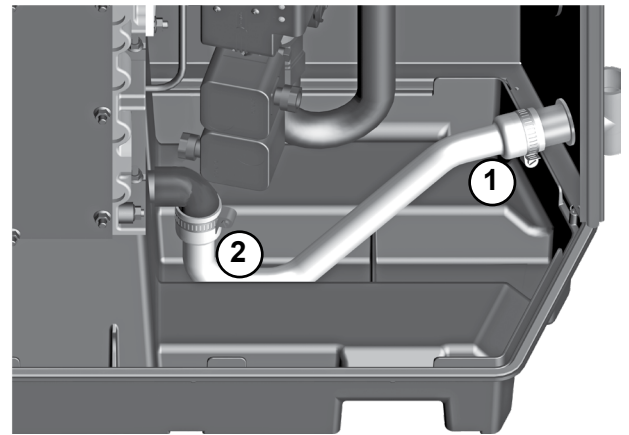
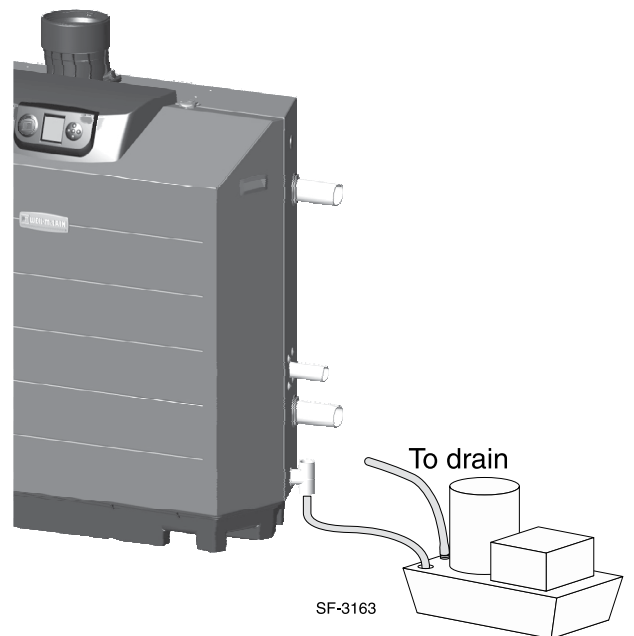

Figure 45 Condensate pump (by others), typical



NOTICE For a condensate pump equipped with an overflow switch, the switch can be connected to the external manual reset or automatic reset limit terminals of the Control. This would shut down the boiler in the event of a condensate overflow. See the wiring diagram for location of the wiring terminals.

Figure 43 Condensate pump capacity, GPH

Minimum recommended condensate pump capacity per boiler, GPH			
SF-550	14	SF-750	20

Gas piping

Connecting gas supply piping

- Remove jacket front panel. See Figure 46 to connect gas supply pipe to the boiler.
 - Install a union for servicing, recommended.
 - Install a manual shutoff valve in the gas supply piping, within 6 feet of the boiler.
 - In Canada, the manual gas valve must be identified by the installer.
- Support piping with hangers, not by the boiler or its accessories.
- Purge all air from the gas supply piping.
- Before placing the boiler in operation, check the boiler and its gas connection for leaks.
 - Close manual main shutoff valve during any pressure testing at less than 20" w.c.
 - Disconnect the boiler gas connection from the gas supply piping during any pressure testing greater than 20" w.c.

WARNING Do not check for gas leaks with an open flame — use a soapy water bubble test. Failure to eliminate gas leaks can cause severe personal injury, death or substantial property damage.

- Use pipe dope compatible with propane gases. Apply sparingly only to male threads of pipe joints so that pipe dope does not block gas flow.

WARNING Failure to apply pipe dope as detailed above can result in severe personal injury, death or substantial property damage.

WARNING SlimFit boilers are shipped ready to fire natural gas ONLY. You must install the propane conversion kit if the boiler will be connected to propane. See [page 8](#) through [page 10](#) for instructions. Failure to comply could result in severe personal injury, death or substantial property damage.

WARNING Install a 100% lockup gas pressure regulator in the gas supply line if inlet pressure can exceed 14" w.c. at any time. Adjust the lockup regulator for 7 to 10" w.c. inlet pressure. This setting provides a cushion below the setting of the high gas pressure switch. Failure to comply could result in shutdown by the high gas pressure switch, resulting in possible serious property damage due to freeze-up.

Natural Gas:

Pipe sizing for natural gas

- Size gas supply piping from meter outlet to entrance of boiler in accordance with [Figure 49, page 49](#) and [Figure 50, page 49](#). Gas pipe must be properly sized with a 100% lockup gas pressure regulator in the gas supply line. An undersized gas pipe feeding the boiler(s) can cause problems.
- Use the total input of all boilers. Divide the total input in Btuh by 1,000 to obtain cubic feet per hour of natural gas.
 - Pipe lengths in [Figure 49, page 49](#) are equivalent lengths of straight pipe. Use [Figure 50, page 49](#) to determine equivalent length of fittings.
 - [Figure 49, page 49](#) is only for natural gas with specific gravity 0.60, with a pressure drop through the gas piping of 0.30" w.c.

WARNING

Use two wrenches when tightening gas piping at boiler, using one wrench to prevent the boiler gas line connection from turning. Failure to support the boiler gas connection pipe to prevent it from turning could damage gas line components.

Figure 46 Connect gas supply piping

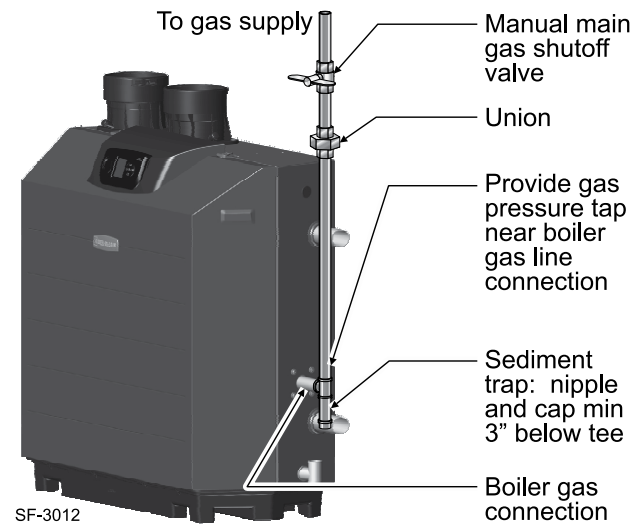
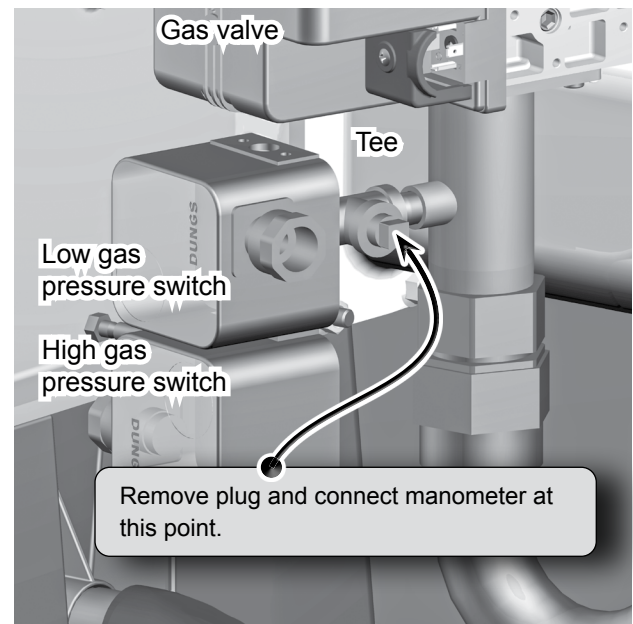

Figure 47 Location of gas train inlet pressure tap





Gas piping *(continued)*

- c. For additional gas pipe sizing information, refer to ANSI Z223.1 (or B149.1 or B149.2 for Canadian installations).

Natural gas supply pressure

Pressure required at gas pressure tap near boiler gas connection (see Figure 46, page 48):

- d. Maximum: 14" w.c. with no flow (lockup) or with boiler on.
- e. Minimum: 3.5" w.c. with gas flowing (verify during boiler startup, while boiler is at high fire).
- f. If no external pressure tap is available, connect manometer to the gas pressure switch tee (Figure 47, page 48). At this point, the minimum gas pressure required is 3.0" w.c.

Propane Gas:

⚠WARNING You must follow the instructions in this manual, beginning on page 8, to operate the boiler on propane. Failure to comply could result in severe personal injury, death or substantial property damage.

Pipe sizing for propane gas

Contact gas supplier to size pipes, tanks and 100% lockup gas pressure regulator. Gas pipe must be properly sized with a 100% lockup gas pressure regulator in the gas supply line. An undersized gas pipe feeding the boiler(s) can cause problems.

Propane supply pressure

Pressure required at gas pressure tap near boiler gas connection (see Figure 46, page 48):

- g. Maximum: 14" w.c. with no flow (lockup) or with boiler on.
- h. Minimum: 3.5" w.c. with gas flowing (verify during boiler startup, while boiler is at high fire).
- i. If no external pressure tap is available, connect manometer to the gas pressure switch tee (Figure 47, page 48). At this point, the minimum gas pressure required is 3.0" w.c.

Manifolded gas supply lines

1. Construct gas header for multiple boilers using Figure 48 and the sizing tables below. Refer to the National Fuel Gas Code for other conditions.
2. Provide manual shutoff gas valve, union and sediment trap (minimum 3 inches below tee) as shown in Figure 46, page 48 and Figure 48 for each boiler.
3. A 1¼" NPT gas piping riser from header to boiler will be large enough for most jobs. Ensure the piping is large enough so that the minimum pressure at the boiler, with all connected appliances firing, will be as specified for natural gas or propane as specified on this page.
4. A 100% lockup regulator should be installed per the regulator manufacturers installation instructions.

Figure 48 Common gas line for multiple boilers

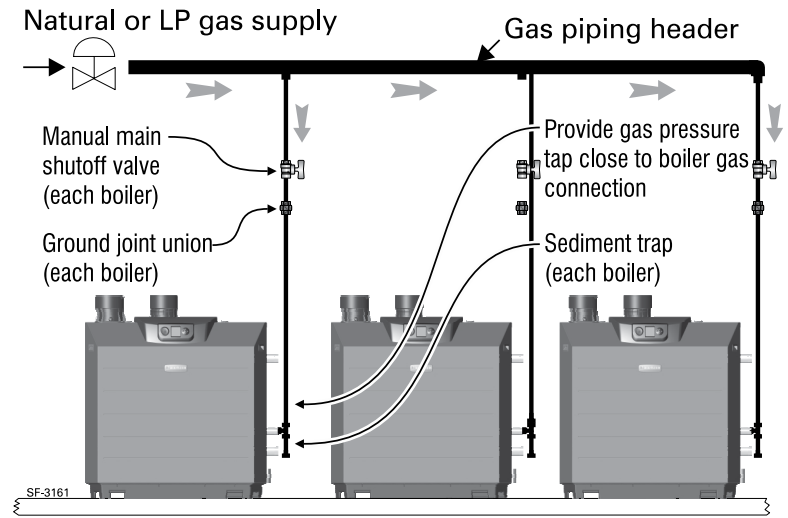

Figure 49 Pipe capacity for natural gas

Gas pipe total length (feet)	Gas supply pipe capacity (cubic feet per hour) @ 0.30" w.c. pressure drop (cubic feet per hour, 0.60 specific gravity)			
	1¼"	1½"	2"	2½"
10	1050	1600	3050	4800
20	730	1100	2100	3300
30	590	890	1650	2700
40	500	760	1450	2300
50	440	670	1270	2000
75	360	545	1020	1650
100	305	460	870	1400
150	250	380	710	1130

Figure 50 Equivalent lengths of straight pipe for gas line fittings

Pipe size inches	Equivalent length, feet	
	90° Elbow	Tee
1¼	3.45	6.90
1½	4.02	8.04
2	5.17	10.3
2½	6.16	12.3

Gas pressure switches

1. SlimFit Commercial boilers are equipped with manual reset high gas pressure and low gas pressure switches (see items 30 and 31, page 3).
2. These switches are factory set and should remain at the following settings:
 - a. High gas pressure: 14 inches w.c.
 - b. Low gas pressure: 2 inches w.c.
3. Note that the low gas pressure switch must be manually reset (button on front of switch) on initial start-up or any time the gas supply is turned off.

Field wiring

(see Wiring Diagrams [Figure 52, page 60](#) & [Figure 53, page 62](#))

⚠ WARNING

ELECTRICAL SHOCK HAZARD — For your safety, turn off electrical power supply at service entrance panel before making any electrical connections to avoid possible electric shock hazard. Failure to do so can cause severe personal injury or death.

NOTICE

The installation must comply with National Electrical Code and any other national, state, provincial or local codes or regulations. In Canada, CSA C22.1 Canadian Electrical Code Part 1, and any local codes.

Wiring must be N.E.C. Class 1. If original wiring as supplied with boiler must be replaced, use only type 105 °C wire or equivalent. Boiler must be electrically grounded as required by National Electrical Code ANSI/NFPA 70 – latest edition.

Do not use 24V from transformer to power any external devices that are not listed in this manual.

Wire entrances

Eight knockouts are provided in the top of the cabinet for line and low voltage wiring. See Figure 51 for locations.

⚠ WARNING

Installer MUST use a strain relief through jacket knockouts. Failure to do so can cause severe personal injury, death or substantial property damage.

Wiring overview

See details on the following pages for the wiring connections outlined below:

Required wiring connections

- 120VAC power to boiler; 120VAC power out to boiler circulator; system supply and return temperature sensors.

Connections as needed by systems

- Thermostat, end switch or other inputs for call for heat.
- System zone circulators, valves, relays, etc.
- System circulator, when required.
- Outdoor temperature sensor.

Optional wiring connections

- External limits; proof-of-closure interlocks (combustion air damper, flow switch, etc.); 0–10VDC for target or modulation control; remote alarm; additional heat demand contact; and communication cables for boiler networking and/or building management system interface (MODBUS).

Figure 51 Wire entrances

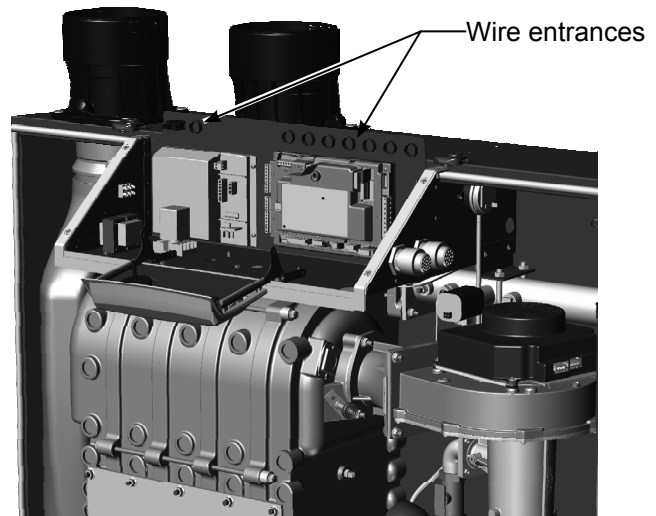

SF-7020



Field wiring (see Figure 52, page 60 & Figure 53, page 62) (continued)

A. 120 VAC Power Supply – REQUIRED

Terminal Block (control panel, left side)

1. Boiler line voltage power — Boiler load is 18 amps. Provide and install a fused disconnect or service switch (25- or 30-ampere rated recommended) as required by applicable codes.
2. Connect properly sized **120 VAC** power wiring to SlimFit boiler line voltage terminal strip as shown at right.
3. If possible, provide a surge suppressor in the supply power line. This will reduce the possibilities of control damage due to line surges.
4. Must wire ground to this terminal to provide boiler grounding.

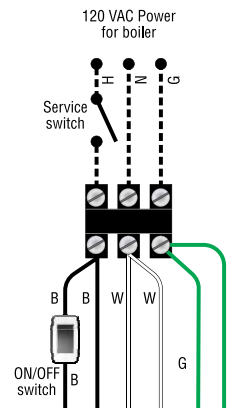

See Figure 52, page 60 for details

B. 120 VAC Outputs 1, 2 & 3 – On each boiler – As needed for systems

Terminal Strip P2 (SlimFit control module, right side)

1. Output 1: P2 Terminals 1 (H), 4 (N), 7 (G).
2. Output 2: P2 Terminals 2 (H), 5 (N), 8 (G).
3. Output 3: P2 Terminals 3 (H), 6 (N), 9 (G).
4. Maximum load: 2.2 amps (use relay if circulator load is higher). See WARNING below.
5. Each boiler has three outputs (Output 1, Output 2, and Output 3) that provide 120 VAC to the following listed below.
 - A zone circulator.
 - A system circulator.
 - A DHW circulator (used to circulate through an indirect tank).
 - An auxiliary item that must be energized during an input call, such as an air damper.
6. When using inputs/outputs for heat/DHW demands, each input (Input 1, Input 2, and Input 3) controls its respective 120 VAC output (Output 1, Output 2, and Output 3). Outputs are energized only when BOTH conditions below are met:
 - a. The corresponding input indicates a call for heat/DHW (i.e., contact closure).
 - b. The PRIORITY assigned to the Input/Output pair is ACTIVE (i.e., the zone may be calling but the pump won't activate unless the boiler is currently running on that system/priority).
7. When using the inputs/outputs for the AUX PUMP/OUTPUT function, the output is controlled by selectable conditions set up in the control.
 - a. Use the AUX PUMP/OUTPUT function for devices such as system pumps, combustion air dampers, and other auxiliary equipment to activate when the boiler is on/running.
 - b. See page 75 and page 76 for more information on the setup and selection of operating conditions.

Circulators (2.2 amps max) or Zone valves (120 VAC)

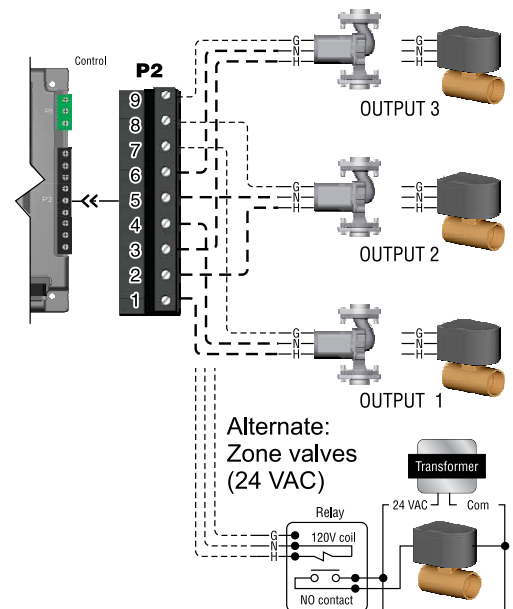

See Figure 52, page 60 for details

NOTICE

For Priority DHW Application:

The DHW aquastat can be connected to any one of the three input/output pairs. The selected input should be assigned to PRIORITY 1 during the WIZARD setup or manually in the ASSIGN INPUTS menu.

WARNING

Output circuits are 120 VAC. If an output is to operate a low voltage circuit or must be an isolated contact, use an isolation relay. See example above for 24 VAC zone valves.

WARNING

CIRCULATOR POWER — The maximum allowable current for each circulator is 2.2 amps at 120 VAC.

For circulators with higher amp ratings, install a circulator relay or starter. Connect only the 120 VAC coil to the SlimFit circulator terminals.



Field wiring (see [Figure 52, page 60](#) & [Figure 53, page 62](#)) (continued)

C. 120 VAC to Boiler Circulator – REQUIRED

Terminal Strip EP7 (BOILER CIRC) (Expansion module, top right)

1. Provides 120 VAC Dry Contact for boiler circulator.
2. Terminals are: 1 (H), 2 (H).
3. Maximum load: 10 amps (use relay if circulator load is higher).
4. Provide and install a fused disconnect or service switch (15-ampere rated recommended) as required by applicable codes for circulator with maximum load of 10 amps.
5. The boiler circulator is used in the boiler loop of the primary / secondary piping. Primary / secondary piping is recommended to be used with the SlimFit boiler to ensure proper flow through the heat exchanger.

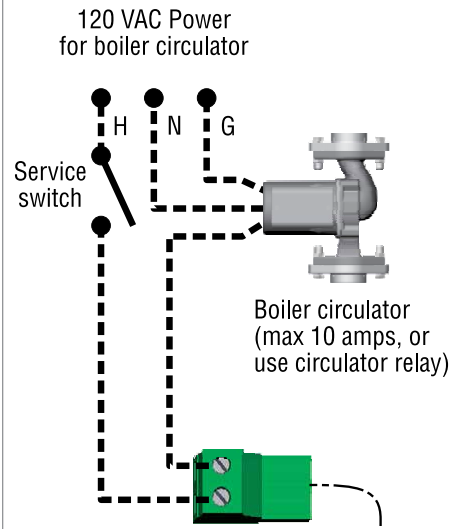

See [Figure 52, page 60](#) for details

D. 24 VAC Inputs 1, 2 and 3 (tstats, end switches, etc.) – As needed for systems

Terminal Strip P11 (input 1) & Terminal Strip P15 (inputs 2 & 3) (SlimFit control module, left side)

1. Input 1 – Terminal Strip P11 – 4 & 5 (SlimFit control module).
2. Input 2 – Terminal Strip P15 – 1 & 2 (SlimFit control module).
3. Input 3 – Terminal Strip P15 – 3 & 4 (SlimFit control module).
4. These three inputs on each boiler can indicate a call for heat to the control by means of a dry contact closure (thermostat, aquastat, or switch). (See right and [Figure 52, page 60](#)).
5. The control provides inputs for up to three zones or three systems (priorities).

NOTICE The control default setting is for three space heating zones tied to PRIORITY 2, which is defaulted to FINNED TUBE BASEBOARD system type.

6. For DHW applications, the aquastat can be connected to one of the three input/output pairs. Take advantage of factory default settings by using PRIORITY 1 for the DHW system. The default control setting for PRIORITY 1 is a direct-piped DHW system type.
7. The default control setting uses each input (INPUT 1, INPUT 2, and INPUT 3) to control its respective 120VAC output (OUTPUT 1, OUTPUT 2, and OUTPUT 3).

NOTICE Use of 0–10VDC input for modulation disables Input 1 from creating calls for heat. See [page 57](#) for instructions.

An input can be assigned to an AUX PUMP/OUTPUT function to operate a system pump or interlock with a combustion air damper. Inputs assigned for this function cannot be used for heat demand operation. See [page 75](#) and [page 76](#) for more information on the setup and selection of operating conditions.

TT or end switch inputs

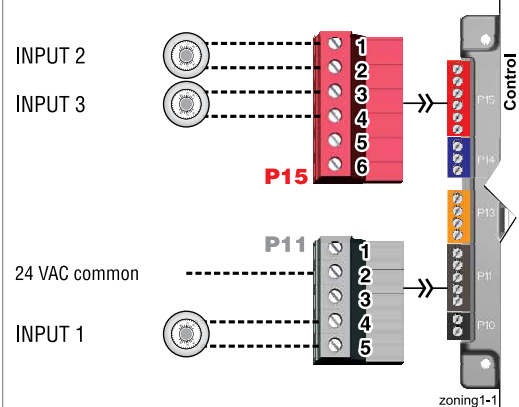

See [Figure 52, page 60](#) for details

WARNING **Thermostats** — DO NOT supply 24-volt power to the thermostat circuits (Input1, Input2 and Input3 in [Figure 52, page 60](#)) or attempt to supply 24 volts for any other application.

For thermostats that require a continuous 24-volt power source, connect the common wire (“C”) to **P11** Pin 2 (see [Figure 52, page 60](#)). Do NOT exceed total amp draw per thermostat.

Zone valves — If using 3-wire zone valves, use relays to provide dry contacts to the Control thermostat connections. The zone valve end switches of 3-wire valves carry 24 VAC from the valve.

Thermostat anticipator setting — 0.1 amps.



Field wiring (see [Figure 52, page 60](#) & [Figure 53, page 62](#)) (continued)

E. System supply and return temperature sensors – REQUIRED

Terminal Block P14 (SlimFit control module, left side)

1. Two strap-on temperature sensors are shipped with each boiler. Attach one to the system supply piping and the other to the system return piping. For piping larger than 5 inch diameter or nonmetallic piping, using immersion sensors will provide faster response. See [Replacement parts, starting on page 108](#) for available immersion sensors.
2. Locate the supply sensor at least six pipe diameters, but no further than 3 feet, downstream from the boiler connection to the main to ensure adequate mixing.
3. Supply sensor – wire between P14 #1 and #2 (common).
4. Return sensor – wire between P14 #3 and #2 (common).
5. Thermostat wire can be used to connect these sensors.
6. The Control compares the system return temperature with the system supply temperature. Should the return temperature ever exceed the supply temperature, the Control knows there is likely a sensor failure and will report this problem on the display.

NOTICE All heating systems shown in this manual require the System Supply and Return sensors to be installed for proper control function. System will not properly provide heat if sensors are not installed according to these instructions.

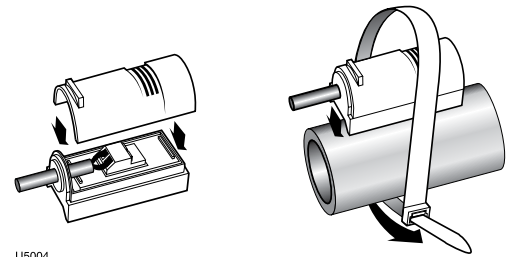

Strap to supply & return piping

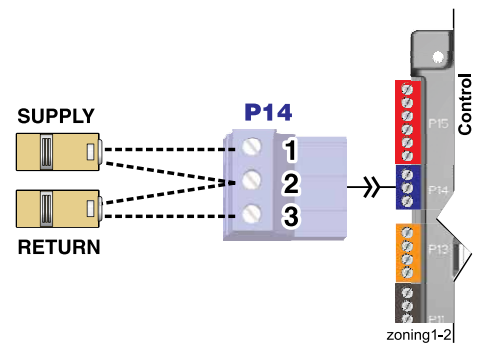

See [Figure 52, page 60](#) for details

F. Outdoor temperature sensor – OPTIONAL

Terminal Block P10 (SlimFit control module, left side)

1. The control provides programmable options if using an outdoor temperature sensor. This sensor is supplied with the boiler.
2. Mount the outdoor sensor on an exterior wall, shielded from direct sunlight or flow of heat or cooling from other sources.
3. The wire outlet on the sensor must be oriented DOWN to prevent water entry.
4. Connect the sensor leads to the terminal shown at right and in the wiring diagrams (see [Figure 52, page 60](#)). Thermostat wire can be used to connect the sensor.

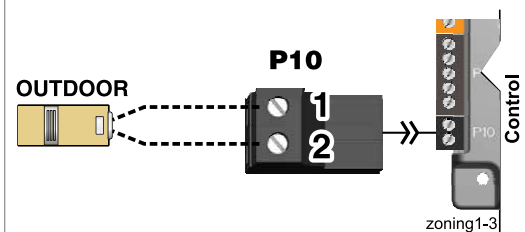

See [Figure 52, page 60](#) for details



Field wiring (see [Figure 52, page 60](#) & [Figure 53, page 62](#)) (continued)

G. External limits – OPTIONAL

To cause MANUAL reset: Terminal Block P13 #1 & #2 (SlimFit control module, left side)

SlimFit control will require manual reset after circuit is interrupted

1. Remove factory-installed jumper and connect isolated contacts of external limits across P13 pins 1 and 2 to cause the control to enter manual reset lockout if the limit circuit opens. The limit must close and the control must be manually reset using the procedure given in this manual. See drawing at right and wiring diagram ([Figure 52, page 60](#)).

NOTICE The control will lockout when a limit in its manual reset circuit opens (P13 pins 1 & 2). The control activates its alarm terminals and shuts the boiler off. An operator (user or technician) must manually reset the control to resume heating. Cycling power on and off will NOT reset the control.

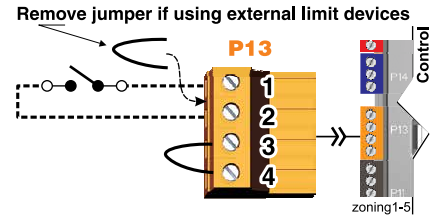

See [Figure 52, page 60](#) for details

To cause AUTOMATIC reset: Terminal Block P13 #3 & #4 (SlimFit control module, left side)

SlimFit control will reset automatically after circuit is interrupted

1. Remove factory-installed jumper and connect isolated contacts of external limits across P13 pins 3 and 4 to cause the control to shut down the burner on limit opening, then automatically restart 150 seconds after the limit closes.
2. See drawing at right and wiring diagram ([Figure 52, page 60](#)).

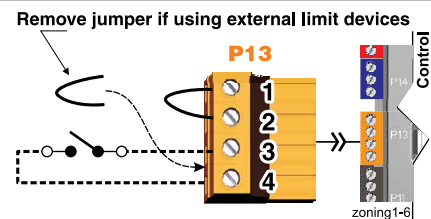

See [Figure 52, page 60](#) for details

H. Alarm contacts – OPTIONAL

Terminal Block P16 #4 & #5 (SlimFit control module, top left)

1. The control's alarm dry contact (P16, terminals 4 and 5) closes when the boiler enters manual lockout only.
2. Connect these terminals for remote alarm notification.
3. Contact electrical ratings: 24 VAC or less; 0.5 amp or less.

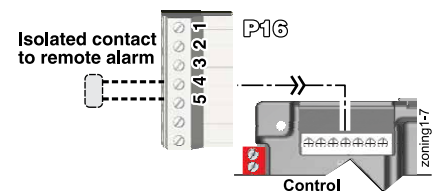

See [Figure 52, page 60](#) for details



Field wiring (see [Figure 52, page 60](#) & [Figure 53, page 62](#)) (continued)

I. Proof of closure (flow switch and/or CAD) – OPTIONAL

Jumper on Terminal Strip P7 (SlimFit control, bottom left of center)

1. A flow switch or combustion air damper (CAD) interlock can be configured by clipping the purple wire attached to Pin 3 of P7 such that there is sufficient room to strip ends and connect to field wiring. Strip the jumper ends and wire components as shown at right and in the wiring diagram (Figure 52, page 60).

NOTICE Do NOT clip wires attached to other pins on P7. Only clip purple wire attached to PIN 3. Damaging the other wires will cause boiler fault and will require part repair or replacement.

2. No control settings are required when using a flow switch.
3. Recommended configuration of the SlimFit control for a CAD interlock:
 - a. Assign **INPUT 3** as a **AUX PUMP/ OUTPUT** function.
 - b. For the **AUX PUMP/OUTPUT** operating mode, select **ANY BURNER DEMAND**. This ensures the damper will be activated any time the boiler is called on to fire.
 - c. **OUTPUT 3** will provide 120VAC to the damper motor. Use an isolation relay if damper motor requires another voltage or more than 2.2 amp if using 120 VAC.

NOTICE * The devices used must provide electrically isolated contacts, because the P7 jumper circuit carries 5 VDC.

NOTICE Ensure that the wires are connected only as shown. The **right side of each jumper must connect only to the right side of other jumpers**. Failure to comply will cause incorrect operation of the proof of closure circuits.

4. When a call for heat occurs, the corresponding output(s) energize, and the blower does not activate until the proof of closure switch is closed and conducting electricity. The boiler is given four (4) minutes to close the proof of closure switch. If the switch opens prior to ignition, the timer continues with the blower remaining active. After four (4) minutes, if the closure switch remains open, or if the closure switch opens during burner firing, the control locks out. The fault will clear when the closure switch returns to a closed state. The corresponding output(s) will remain energized in an attempt to close the switch.

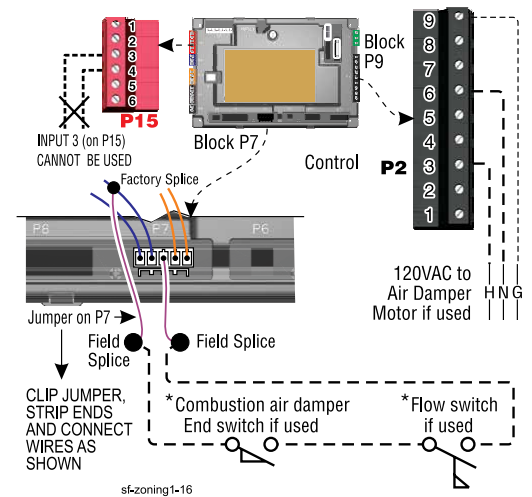

See [Figure 52, page 60](#) for details

Field wiring (see [Figure 52, page 60](#) & [Figure 53, page 62](#)) (continued)

J. 0–10 VDC Remote TARGET input – OPTIONAL

Terminal Block P15 #5 & #6 (SlimFit control module, left side)

1. See illustration at right and [Figure 52, page 60](#) (wiring diagram) for details.
2. Remote target using 0–10VDC input requires a 0–10VDC input signal at P15-4/5 as shown at right.
 - a. The input positive connection must be at P15 terminal 6 and the common connection at terminal 5.
3. This illustration also shows how to connect TT or end switch contacts at INPUT 1, INPUT 2 and INPUT 3.
 - a. If a Heat/DHW demand is required, connect the demand's dry contact to an unused input on the control and its pump/valve to the respective output. Then assign and setup a priority to the input using the Wizard or manually through the contractor menu.
 - b. A dry contact heat demand must be applied to one of the inputs in order to initiate a call for heat.
4. The 0–10VDC signal is used to adjust the supply target temperature, using the TARGET ADJUST setting. Set TARGET ADJUST during the WIZARD or manually in the PRIORITY SETTINGS menu for the desired PRIORITY.
 - a. Many options are available for configuring the control. The following is a suggested setup that uses factory default settings as much as possible.
 - b. Use PRIORITY 1 for the DHW heating system when used. This priority's default values are set for DHW, direct-piped to the boiler. Verify that settings are suitable for the application, change if needed.
 - c. Use PRIORITY 2 for the heating systems.
 - For single boilers, the factory default settings for PRIORITY 2 make this priority a good choice for space heating applications. Set PRIORITY 2 values to the following:
 - Set TARGET ADJUST value to 0–10V.
 - Set VOLTS FOR MAX at the voltage that will call for the highest target temperature. Set SUPPLY MAX at this temperature.
 - Set VOLTS FOR MIN at the voltage that will call for the lowest target temperature. Set SUPPLY MIN at this temperature.
 - For voltages between VOLTS FOR MAX and VOLTS FOR MIN, the target temperature will range proportionately between SUPPLY MAX and SUPPLY MIN. See the SlimFit Advanced Manual for a full discussion.

NOTE: The 0–10VDC signal replaces the ODT sensor as the target temperature modifier (TARGET ADJUST setting). The control does not control target.

TT or end switch inputs
(INPUTS 1, 2, and 3)

With External 0–10VDC input

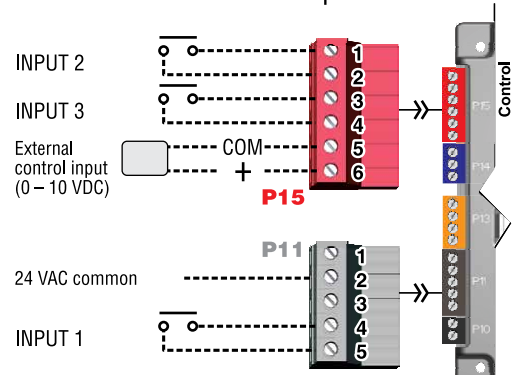

See [Figure 52, page 60](#) for details

Field wiring (see [Figure 52, page 60](#) & [Figure 53, page 62](#)) (continued)

K. 0–10 VDC Remote MODULATION input – OPTIONAL

Terminal Block P15 #5 & #6 (SlimFit control module, left side)



Using an external multiple boiler controller — Remote modulation using an external controller only works with each boiler set up as a SINGLE boiler in the SlimFit Control setup.

1. See illustration at right and [Figure 52, page 60](#) for details.
2. This illustration also shows how to connect TT or end switch contacts at INPUT 2 and INPUT 3 for other uses.
3. This function can only be used with a single boiler, NOT for a boiler in a network.
4. Note that using 0–10VDC input replaces INPUT 1 to generate a heat demand as shown at right.
5. Remote modulation requires a 0–10VDC input signal at P15-4/5 as shown at right.
 - a. The 0–10VDC input positive connection must be at terminal 6 and common connection at terminal 5.
6. Control setup:
 - a. Many options are available for configuring the control. The following is a suggested setup that uses factory default settings as much as possible.
 - b. If DHW is required, use PRIORITY 1 to minimize setup steps.
 - Connect the DHW aquastat to INPUT 2 or INPUT 3 and assign the input used to PRIORITY 1.
 - Verify that control settings are suitable for the application, changing if necessary.
 - c. Use PRIORITY 2 for the system to be remote modulated.
 - The factory default settings for this priority are best suited for space heating.
 - Assign INPUT 1 to the priority chosen. Accept all defaults for INPUT 1 — no changes should be necessary during the WIZARD.
 - After the WIZARD has been completed, go to the ASSIGN INPUTS menu for INPUT 1. Change SOURCE to 0–10V (default setting is TT1). See [page 75](#) for ASSIGN INPUTS menu information.
7. Operation:
 - a. A heat demand is activated at 0.9VDC and turns off at 0.8VDC. 2 VDC = 20% input. 10 VDC = 100% input. These voltage settings are not adjustable.
 - b. OUTPUT 1 (120 VAC) is activated and deactivated as the heat demand is turned on and off. This output is a good choice to operate the system pump.
8. NOTE: The SlimFit control can be configured to use either 0–10VDC for target operation (see previous section) or modulation, **but not both**.

TT or end switch inputs (INPUTS 2, 3)
With External 0–10VDC input

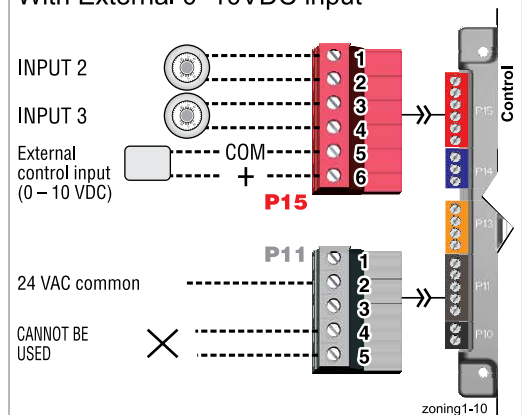

See [Figure 52, page 60](#) for details

L. 120 VAC Power Receptacle

Located on boiler right side panel

1. Electrical rating is 2.0 amps max at 120 VAC.
2. This receptacle can be used to plug in a condensate pump.



Field wiring (see [Figure 52, page 60](#) & [Figure 53, page 62](#)) (continued)

M. Multiple Boiler and BMS Connections – see **ADVANCED Manual**

Terminal Strips P11 and P12 on Expansion Module (Expansion module, right side)

1. The boiler control is capable of multiple boiler communication and control of up to eight boilers in one installation.
2. The boiler control is also capable of BMS communication.
3. See SlimFit Advanced Manual for multiple boiler installation and setup information.

See SlimFit Advanced Manual for details

N. Additional heat demand contacts – **OPTIONAL**

Terminal Block P16 Pins #6 & #7 (SlimFit control module, top left)

1. The control module can be set to activate another heat source using its additional heat demand dry contacts through terminal block P16 pins 6 & 7.
2. Connect these terminals to call for heat from the other heat source.
3. Contact electrical ratings: 24VAC or less; 0.5 amp or less.
4. Set the control to activate the heat demand contacts as needed.
5. See SlimFit Advanced Manual to configure.

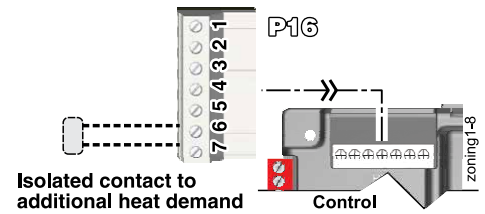

See [Figure 52, page 60](#) for details

O. 0-10 VDC Output Section

Terminal Block P16 Pins #1 & #2 (SlimFit control module, top left)

1. The control module can be set to activate another heat source using its 0-10VDC Output through terminal block P16 pins 1 & 2.
2. Connect these terminals to 0-10VDC inputs on another heat source to control its modulation rate.
3. Maximum electrical ratings: 10VDC; 108μ A.
4. Set the control to activate the output as needed.
5. See SlimFit Advanced Manual to configure.

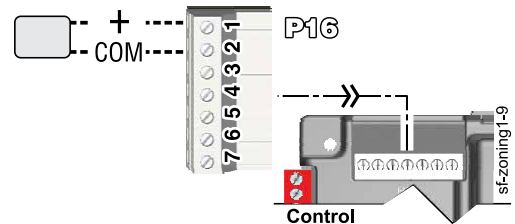

See [Figure 52, page 60](#) for details



Wiring Diagrams

Figure 52 Schematic wiring diagram — SF-550 & SF-750 (continued on next page)

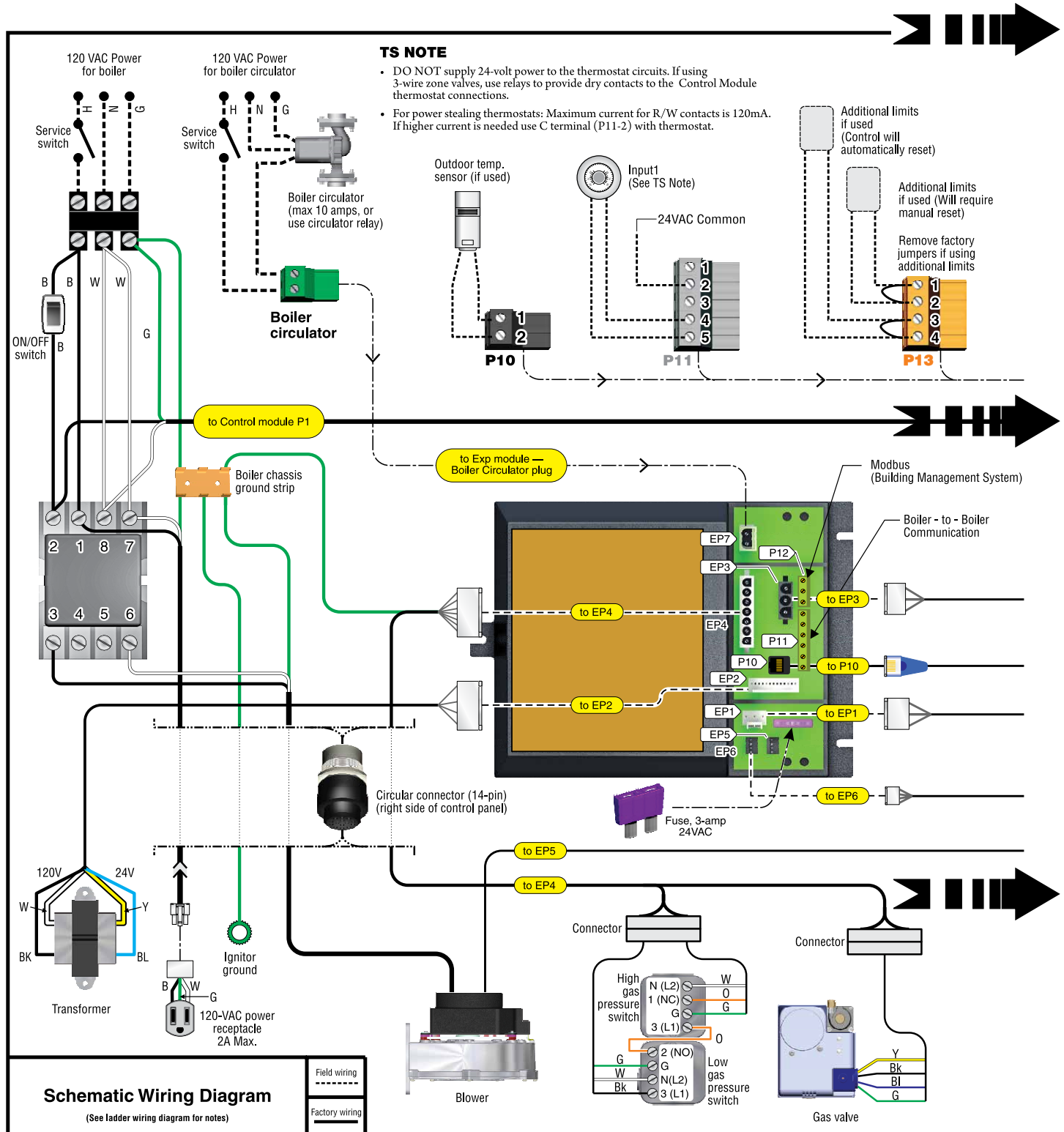



Wiring Diagrams (continued)

Figure 52 (continued from previous page) Schematic wiring diagram — SF-550 & SF-750

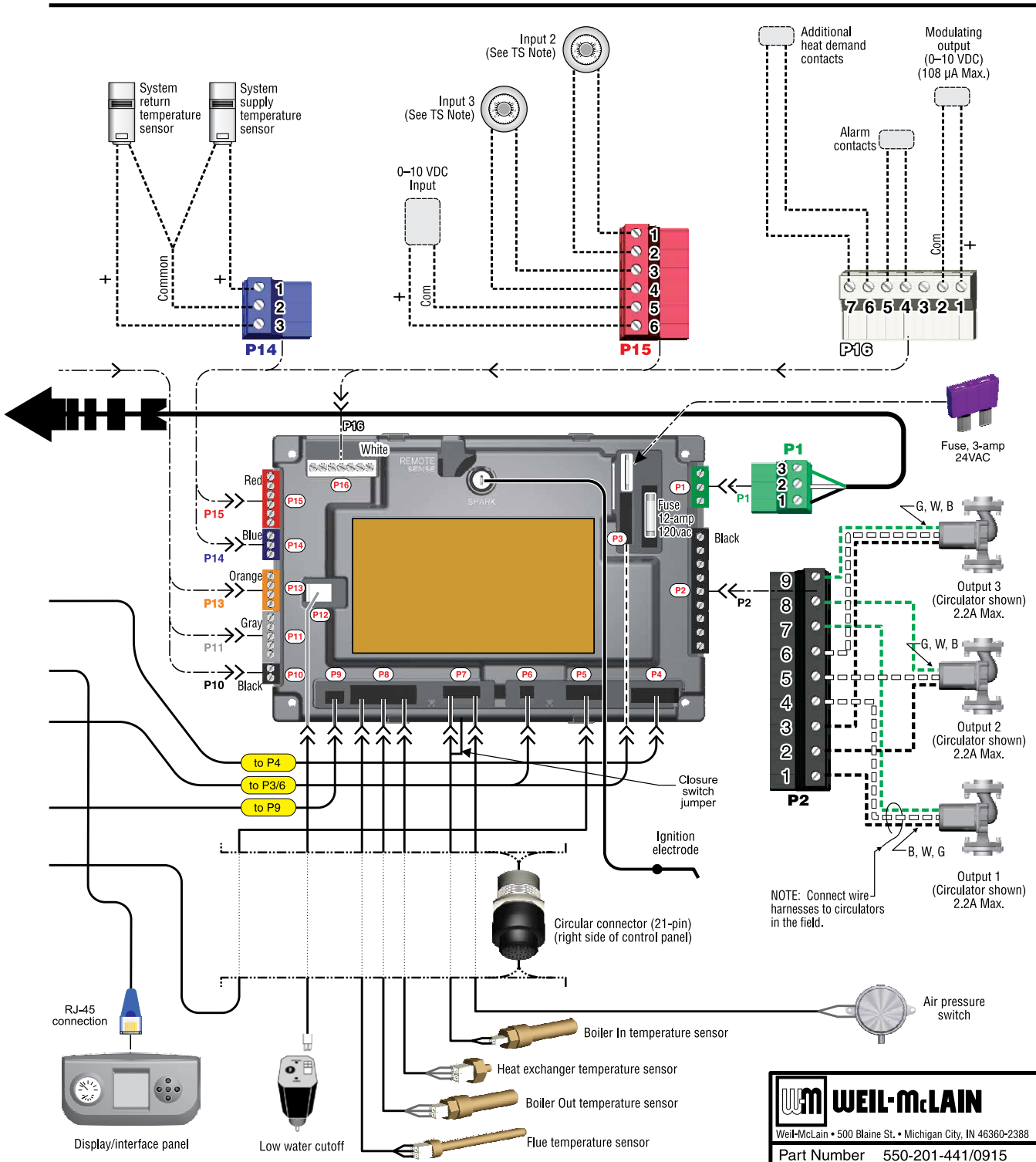



Wiring Diagrams (continued)

Figure 53 Ladder wiring diagram — SF-550 & SF-750 (continued on next page)

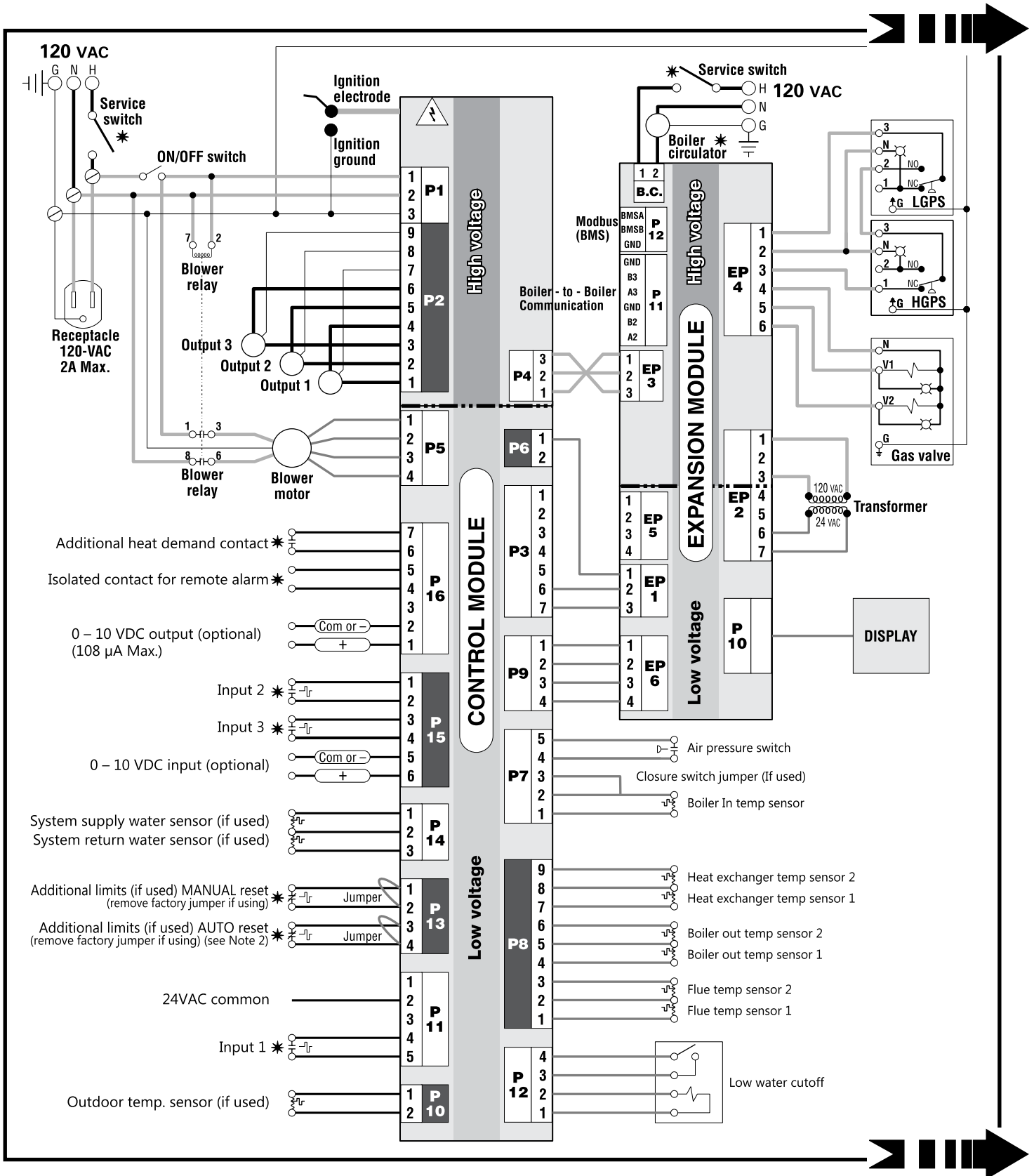



Wiring Diagrams (continued)

Figure 53 (continued from previous page) Ladder wiring diagram — SF-550 & SF-750

Ladder Wiring Diagram

⚠ WARNING

Electrical shock hazard — can cause severe injury or death. Disconnect power before installing or servicing.

NOTICE

All contacts shown without power applied.
 * Indicates items not provided

Legend for ladder wiring diagram only

	120 vac field wiring
	Low voltage field wiring
	120 vac factory wiring
	Low voltage factory wiring
	High voltage spark ignition wiring
	Ground connectors

Notes for Schematic and Ladder Diagrams

1. All wiring must be installed in accordance with:
 U.S.A. — N.E.C. And any other national, state, or local code requirements.
 Canada — C.S.A. C22.1 C.E.C. Part 1 and any other national, provincial, or local code requirements.
2. Connect additional limits (if used) between terminals P13-1 and P13-2 if the boiler control module is to manual reset on limit action. Connect between terminals P13-3 and P13-4 for automatic reset. Remove jumper across terminals used.
3. If any of the original wire as supplied with the appliance must be replaced, use minimum 105 °C wire or equivalent. Exceptions: Ignition lead wire must be obtained from Weil-McLain only.
4. Thermostat anticipator setting (single zone) — set anticipator for 0.1 amps.
5. For multiple zoning, use either zone valves or circulators. Refer to the component manufacturer's instructions and this manual for application and wiring suggestions. Boiler circulator must remain with boiler, and cannot be used for system circulation in any way.
6. Refer to control component instructions packed with the boiler for application information.

WEIL-McLAIN
Weil-McLain • 500 Blaine St. • Michigan City, IN 46360-2388
Part Number 550-201-440/0915



Zoning with the SlimFit Control

A. Zoning with CIRCULATORS, suggested applications

Three space heating zones (no DHW)

1. Review wiring information on [page 60](#) (120VAC outputs) and [page 52](#) (24VAC inputs).
2. The configuration at right uses the three input/output pairs to receive thermostat inputs on P11-4/5, P15-1/2, and P15-3/4; and circulator outputs on P2 as shown.
3. The factory default settings assign all inputs 1, 2 and 3 to PRIORITY 2.
4. Choose the space heating system type that matches the heating system during the WIZARD setup or manually in the PRIORITY 2 menu.
5. Use the factory default settings for the system type chosen, or change if needed.
6. Factory defaults should work for other settings not listed above.

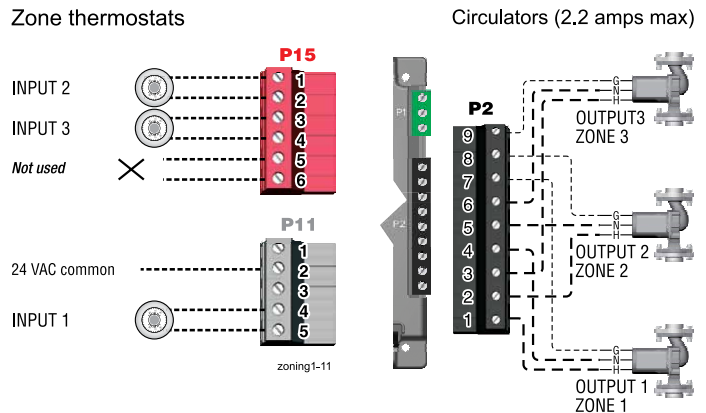

Two space heating zones plus DHW piped directly to boiler

1. Review wiring information on [page 60](#) (120VAC outputs) and [page 52](#) (24VAC inputs).
2. The configuration at right uses INPUT 2 and 3 for space heating thermostats. INPUT 1 uses the input from a DHW aquastat.
3. The factory default settings assign inputs 1, 2 and 3 to PRIORITY 2. Keep inputs 2 and 3 assigned to PRIORITY 2. To set up PRIORITY 2, choose the space heating system type that matches the heating system during the WIZARD setup or manually in the PRIORITY 2 menu.
4. Assign INPUT 1 to PRIORITY 1, which is factory default configured for DHW applications.
5. Use the factory default settings for DHW and for the heating system type chosen, or change if needed.
6. Factory defaults should work for other settings not listed above.

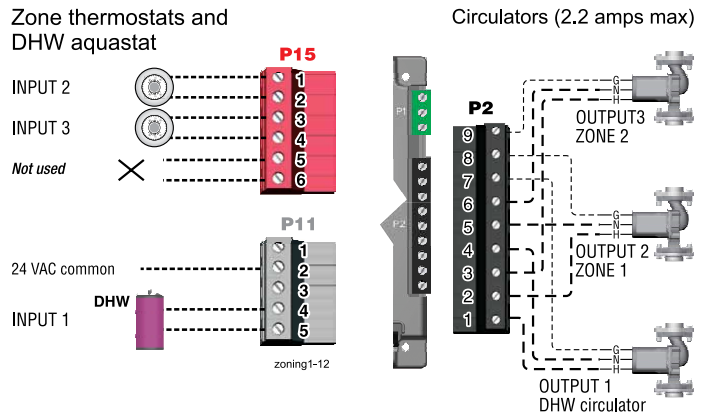

WMCR circulator zone controller plus DHW controlled by boiler, DHW piped directly to boiler

1. Review wiring information on [page 60](#) (120VAC outputs) and [page 52](#) (24VAC inputs).
2. To shut down Space Heating during DHW operation: Provide and connect relay R1 (120VAC coil with NC contact) to interrupt the Zone controller's ZC-ZR (120VAC operating circuit).
3. The configuration at right uses INPUT 2 for space heating with the call for heat coming from the zone controller (X-X). INPUT 1 uses the input from a DHW aquastat.
4. The factory default settings assign inputs 1, 2 and 3 to PRIORITY 2. Keep input 2 assigned to PRIORITY 2. To set up PRIORITY 2, choose the space heating system type that matches the heating system during the WIZARD setup or manually in the PRIORITY 2 menu.
5. Assign INPUT 1 to PRIORITY 1, which is factory default configured for DHW applications. Wire the DHW circulator to OUTPUT 1.
6. Use the factory default settings for DHW and for the heating system type chosen, or change if needed. Factory defaults should work for other settings not listed above.

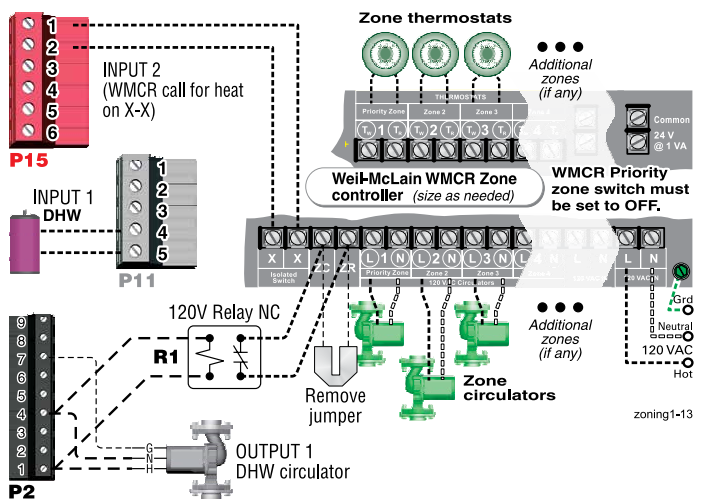

P15, P11 and P2 are terminal strips on the control



Zoning with the SlimFit Control *(continued)*

B. Zoning with ZONE VALVES, suggested applications

Two space heating zones (no DHW)

1. Review wiring information on [page 60](#) (120VAC outputs) and [page 52](#) (24VAC inputs).
2. The configuration at right uses INPUT 2 and 3 for space heating thermostats. INPUT 1 is reserved here for configuring the operation of the system circulator.
3. The factory default settings assign inputs 1, 2 and 3 to PRIORITY 2. Keep inputs 2 and 3 assigned to PRIORITY 2. To set up PRIORITY 2, choose the space heating system type that matches the heating system during the WIZARD setup or manually in the PRIORITY 2 menu.
4. Use the factory default settings for the heating system type chosen, or change if needed.
5. Assign INPUT 1 to AUX PUMP/OUTPUT. Then select ANY INPUT BY ITS PRIORITY when prompted for when to activate the output. This will cause the system pump to run when either of the zones calls for heat. Confirm that Priority 2 RUN AUX PUMP/OUT is set to YES.
6. INPUT 1 (P11-4/5) cannot be used for a wired connection (as shown at right) because it is being used in the control setup to run the system circulator.
7. Factory defaults should work for other settings not listed above.

WARNING The system must be equipped with a by-pass pressure regulating valve. Flow can occur with zone valves closed.

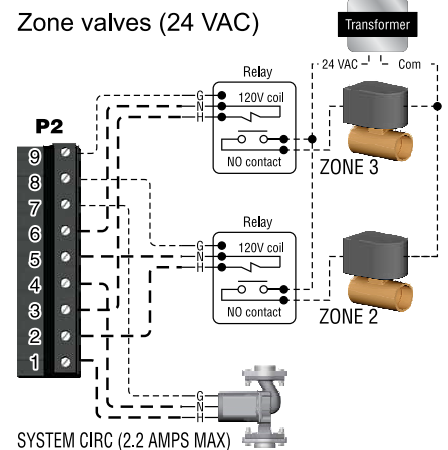
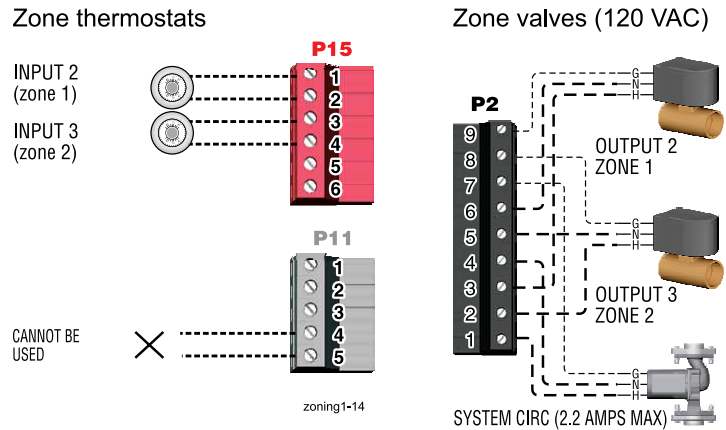

WMZV zone valve zone controller plus DHW controlled by boiler, DHW piped directly to boiler

1. Review wiring information on [page 60](#) (120VAC outputs) and [page 52](#) (24VAC inputs).
2. The configuration at right uses INPUT 2 for space heating with the call for heat coming from the zone controller (X-X). INPUT 1 uses the input from a DHW aquastat.
3. The factory default settings assign inputs 1, 2 and 3 to PRIORITY 2. Keep input 2 assigned to PRIORITY 2. To set up PRIORITY 2, choose the space heating system type that matches the heating system during the WIZARD setup or manually in the PRIORITY 2 menu.
4. The system circulator, wired to OUTPUT 2, will turn on whenever there is a call for heat from the zone controller.
5. Assign INPUT 1 to PRIORITY 1, which is factory default configured for DHW applications. Wire the DHW circulator to OUTPUT 1.
6. Use the factory default settings for DHW and for the heating system type chosen, or change if needed. Factory defaults should work for other settings not listed above.

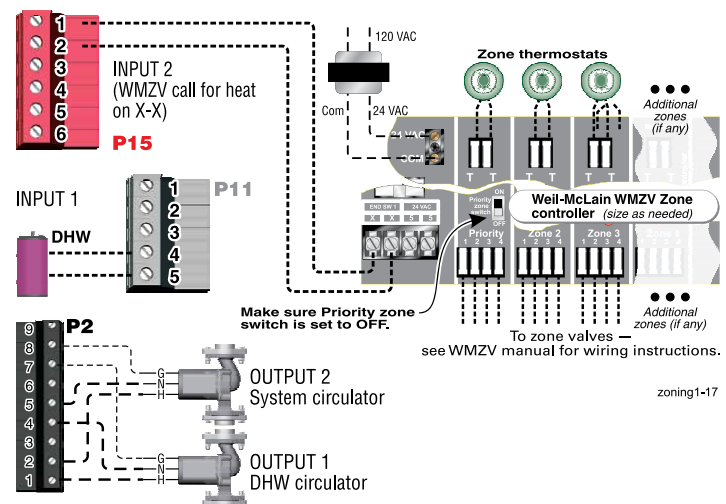

P15, P11 and P2 are terminal strips on the control



Control operation and setup

Control setup

1. Set control parameters using the WIZARD option provided on initial start-up or manually enter parameters using control menus (see [Figure 61, page 72](#) and following pages for information.)
2. See instructions beginning on [page 67](#) for basic systems and minimum settings required (using factory defaults).
3. This manual provides set-up information for a single boiler using BASIC control setting options. See the SlimFit Advanced Manual for single-boiler advanced settings and for all multiple boiler applications.

WARNING

Boiler Model, Altitude are critical settings. Failure to set correctly could result in severe personal injury, death or substantial property damage.

Temperature settings — You must ensure that the Control is set for the proper water temperatures for the system. Excessive water temperature can cause significant property damage in some applications.

Multi-temperature systems — If the heating system includes circuits that require lower temperature water (radiant slab circuits, for example) as well as higher temperature circuits (DHW, finned tube baseboard, etc.), it is recommended to protect low-temperature circuits with limit controls that are wired to an Control external limit circuit. Failure to provide regulation can result in substantial property damage.

Control features

- Single or multiple boiler control (with lead boiler rotation).
- Graphic and robust text display for ease of operation monitoring and troubleshooting.
- Three programmable priority assignments for up to three heat inputs.
- Preset operating parameters for typical heating systems, including target temperatures, reset curves and circulator assignments.
- Integral outdoor reset option, with reset curves matched to the system type selected.
- ModBus communications for external communication and monitoring.
- 0-10VDC input modulation or remote target input.
- Four pump outputs, 3 – powered, 1– dry contact.
- Additional heat demand operation to call a second heat source to help supply the energy required for heating.
- Advanced PI response to anticipate system needs.
- Flue temperature modifier to target temperature.
- Modulation based on flue sensor and boiler/system supply/return sensors.
- Dual temperature sensors on boiler outlet and flue, providing redundant protection.
- Boiler is shipped with an outdoor sensor and strap on system supply and return sensors.
- Blower speed modulation to control boiler firing rate.
- Alarm relay on error/fault for use with an audible safety.
- CSD-1 Valve set leakage test feature (See Advanced Manual).
- Built-in 0–10 VDC signal generator to allow parallel modulation of multiple boilers; also capable of accepting 0–10 VDC input.
- The boiler is equipped with a low water cutoff, factory wired to the Control, manually reset through the Control.

Sequence of operation

Figure 54 is a summary of the operating sequence for the Control.

- The statuses shown appear in the display as the Control cycles the boiler. See [Figure 58, page 70](#) for screen shots.
- The display will flash red if a problem has been detected.

Figure 54 Control sequence of operation

Display status text	Control action <i>(Also see Figure 58, page 70)</i>
POWER UP	<ul style="list-style-type: none"> • Check the boiler model listed on the power-up screen. If it is not correct, turn off the boiler. See page 73 for instructions to change setting. • When power is turned on, the screen lists sensors that are detected. If any sensor is not listed, make sure it is connected correctly. Turn off power and restart.
Standby	<ul style="list-style-type: none"> • Standby - no calls for heat. • Toggles through no dots, 1 dot, 2 dots, then 3 dots while in standby (wrench symbol will show instead if maintenance is needed).
Blower ON	<ul style="list-style-type: none"> • Call for heat detected. • Display on with BLUE light (space heating) or PURPLE light (DHW). • Start min/max timers if more than one system is calling - highest priority starts first. • Start circulators for this priority setup based upon settings. • Calculate target temp — If sensor temp is below target temp, begin firing sequence. • Blower to ignition speed for prepurge.
Ignition	<ul style="list-style-type: none"> • After prepurge times out, begin ignition cycle. • Activate gas valve and ignition spark. • Continue ignition spark for ignition period. • Turn off spark and use electrode to check for flame signal.
Space Heating	<ul style="list-style-type: none"> • Flame detected. • Release boiler to modulation. • NOTE: If flame is not detected, the gas valve is turned off, blower turns on (postpurge), and control starts cycle again. After 5 failures, the control waits 60 minutes, then tries again. • If priority timer times out, switch to next priority and start priority timer. • If demand satisfied, go to postpurge.
DHW Heating	<ul style="list-style-type: none"> • Flame detected. • Release boiler to modulation. • NOTE: If flame is not detected, the gas valve is turned off, blower turns on (postpurge), and control starts cycle again. After 5 failures, the control waits 60 minutes, then tries again. • If priority timer times out, switch to next priority and start priority timer. • If demand satisfied, go to postpurge.
Blower OFF	<ul style="list-style-type: none"> • Demand satisfied (temperature reaches target temperature or limit setting). • Gas valve off. • Blower to ignition speed for postpurge. • Return to standby after purge.
Maintenance	<ul style="list-style-type: none"> • Display turns BLUE, toggling between graphic screen and maintenance screen (occurs if maintenance schedule timer times out). • Will show during standby only. • Boiler operates as normal.
Error/fault	<ul style="list-style-type: none"> • Display turns RED due to error or limit event. • Flashing display means lockout condition.
WWSD	<ul style="list-style-type: none"> • Warm weather shut down - the boiler will not be allowed to fire on space heating if the outside temperature is greater than the WWSD setting. • DHW operation is not affected by WWSD.



Control operation and setup *(continued)*

Control Priorities & Input/Outputs

- For heating installations with multiple systems, the Control uses PRIORITIES to determine the order of operation of the systems. The control's MAX and MIN time settings determine the maximum and minimum times a system will be operated before being turned off to allow another system to operate. A typical example is DHW priority — heat demand from the DHW system is given preference over space heating, if set to use Priority 1.
- Each PRIORITY has its own set of operating parameters. The control prompts the user to select the system type (finned tube baseboard, DHW, etc.) and is factory programmed with parameters suited to each of these system types. The user can also choose CUSTOM to create a system type.
- The Control provides up to three priorities for single boiler applications and up to four priorities for network boiler applications. The order of operation is: PRIORITY 1, PRIORITY 2, PRIORITY 3.
- The 120VAC power output to the boiler circulator is provided by a relay located on the boiler's Pump/Communications Board. For each of the priorities, the control can be setup to run the boiler pump or to leave it off. It is recommended to set Blr Circ to OFF for DHW that is directly piped with its own DHW Circ.
- Each boiler has three input/output pairs (INPUT/OUTPUT 1, 2 and 3). Control setup prompts the user to assign each of these I/O pairs to a PRIORITY. The Control then knows which system (priority) to operate when the input receives a call for heat. On a call for heat to an input, the Control closes the corresponding output (120VAC) and begins controlling the boilers according to the setup for the assigned priority.
- The MAX ON TIME setting controls the maximum time a priority will be allowed to run before switching to a lower priority's call for heat. The MIN ON TIME setting controls the minimum time a priority will be operated before switching to a higher priority's call for heat, or the next lower priority.
- When multiple inputs are set up on the same priority, they will run at the same time if the priority and inputs are active.

Control operation

- The control responds to signals from:
 - Room thermostats.
 - DHW aquastats (if used).
 - Temperature sensors (boiler return, boiler supply, flue temperature) and, when used, system supply and system return, outdoor temperature). **For optimal performance, it is recommended to install the system supply and return sensors.**
- The control automatically adjusts blower speed (and gas flow rate) to match boiler output to space heating and/or DHW heating demand.
- The control provides three inputs and three outputs (for circulators or auxiliary devices) plus a fourth boiler circulator output.
- The outdoor temperature is used for supply temperature reset operation and for the warm weather shut down (WWSD) option.
- System presets:
 - The Control provides presets by system type (see [Figure 59, page 71](#) for complete list).

Setting Up the Boiler	
Step 1	<ul style="list-style-type: none"> DETERMINE input/output needs – What are the inputs? – Thermostats, remote contacts, end switches, etc. What does each control's output need to do? – operate a pump, activate an air louver, etc.
Step 2	<ul style="list-style-type: none"> Connect wiring to the control inputs and outputs to accomplish the purposes set in Step 1.
Step 3	<ul style="list-style-type: none"> Install the boiler following all instructions in the SlimFit Boiler Manual before proceeding further. See the Advanced Manual for multiple boiler installations. Follow instructions in the Boiler Manual to start up and power the boiler.
Step 4	<ul style="list-style-type: none"> Use the WIZARD (below) or enter control parameters manually (skip Wizard).

Control WIZARD

- The Wizard is available on initial setup of the boiler. It leads through a step-by-step setup procedure designed for the application chosen.
- Context-sensitive help is available to explain the purpose of key setup items.
- Advanced settings for single boiler applications can be accessed manually from the Contractor menu.

WIZARD Sequence	
Boiler Settings	<ul style="list-style-type: none"> Altitude – ⚠WARNING – must be set correctly for proper operation. WWSD – set outdoor temperature above which space heating will be deactivated. Fuel (natural gas or propane) – ⚠WARNING – must be set correctly for proper operation – control will pause until this value is selected.
Inputs/Outputs	<ul style="list-style-type: none"> Select the usage of inputs 1, 2 and 3. Determine usage of outputs 1, 2 and 3 (outputs correspond to inputs).
Set Priorities	<ul style="list-style-type: none"> Assign priorities 1, 2 and 3 to the inputs.
System Settings	<ul style="list-style-type: none"> Set system settings or leave at their defaults.
System Types	<ul style="list-style-type: none"> Specify what system type is connected to each of the three outputs; each system type causes the control to preset. operating temperatures.
Output Activation	<ul style="list-style-type: none"> (When applicable) Select when to activate AUX PUMP/OUTPUT – by input, always on, external switch, etc.
Priority Switching	<ul style="list-style-type: none"> Set maximum and minimum timings for priorities.
Date/Time	<ul style="list-style-type: none"> Set date and time – important for control diagnostic logging.
Information	<ul style="list-style-type: none"> Set installer name and contact information. Enter CP#, install date, maintenance date, etc. Set automatic maintenance notification timing.



Control operation and setup *(continued)*

Outdoor reset operation

1. Set desired temperatures for space heating zones.
2. For an explanation of the target temperatures and associated outdoor temperatures, see Figure 55.
3. The temperature settings discussed below are accessed in the priority menu for the applicable system. For detailed explanations of the priority menus, see [Figure 63, page 74](#).

SUPPLY MAX

1. Set Supply max to the required supply water temperature for the system at design maximum heat loss (typically 180°F for finned tube baseboard on new installations).

SUPPLY MIN

1. Supply min should equal the desired minimum supply water temperature for the system.
2. This could be set as low as 70°F, which would supply “zero heat” when outdoor temperature is 70°F, because supply water temperature would equal room temperature.
3. See examples in Figure 55.

OD RESET MAX

1. OD RESET MAX means the outdoor temperature at which the target temperature reaches its minimum (Supply min).
2. In the examples of Figure 55, this occurs at 70 °F (the factory default).

OD RESET MIN

1. OD RESET MIN means the outdoor temperature at which the target temperature reaches its maximum value (Supply max).
2. In the examples of Figure 55, this occurs at 0°F outside (the factory default setting).
3. OD RESET MIN should equal the ODT (outdoor design temperature) for the installation’s location.

Remote target operation (0–10VDC input)

1. This function allows a remote analog input to regulate the supply temperature for control operation/modulation. This can be done for any priority, including network and local priorities for multiple boiler networks.
2. The settings discussed below are accessed in the priority menu for the applicable system. For detailed explanations of the priority menus, see [Figure 63, page 74](#).
3. See Figure 56 for an explanation of target temperature vs voltage when using remote target operation.
4. In the priority menu for the applicable system, select 0-10v for the TARGET ADJUST setting.
5. In the same priority menu, select the VOLTS FOR MIN and VOLTS FOR MAX values. VOLTS FOR MIN sets the voltage value for the desired minimum supply temperature. VOLTS FOR MAX sets the voltage value for the desired maximum supply temperature.

Figure 55 Outdoor reset operation

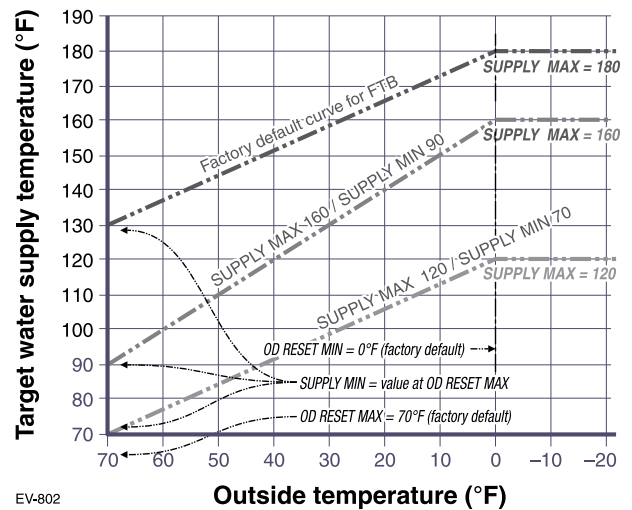

EV-802

Figure 56 Remote target operation

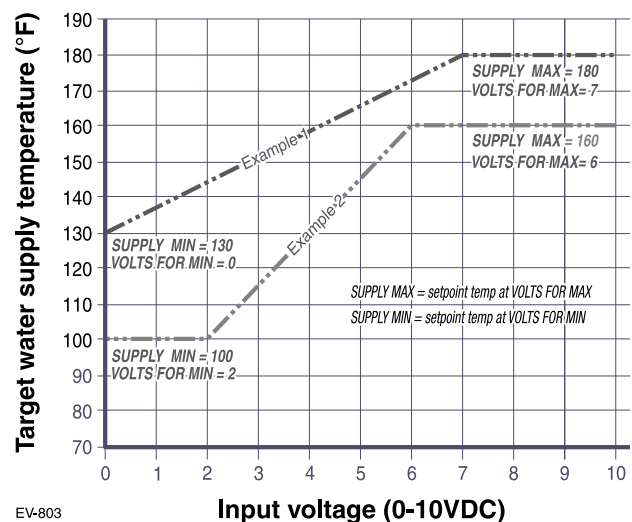

EV-803

Remote modulation operation (0–10v input)

1. To use 0-10VDC for remote modulation, go to Contractor Menu -> Assign Inputs. Then change Input 1’s source to 0-10V. The priority that is assigned to Input 1 cannot be used by any other Input.
2. The boiler comes on at 0.9VDC and turns off at 0.8VDC. 2 VDC = 20% input. 10 VDC = 100% input. These voltage settings are not adjustable.



Control operation and setup (continued)

Figure 57 SlimFit single boiler essential settings (REQUIRED on initial start-up) — see page 71 for explanation

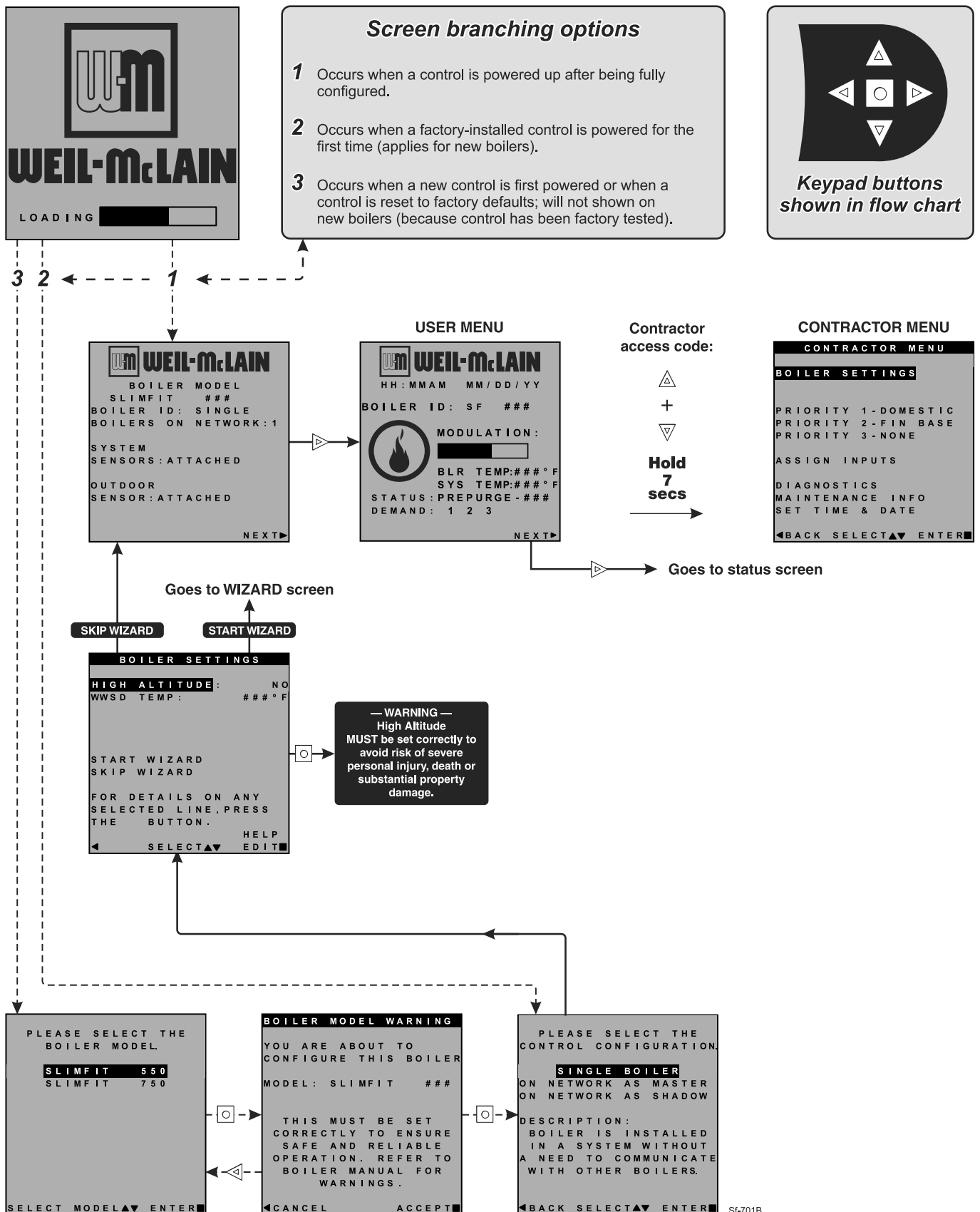



Control operation and setup (continued)

Figure 58 SlimFit control display screens and typical navigation

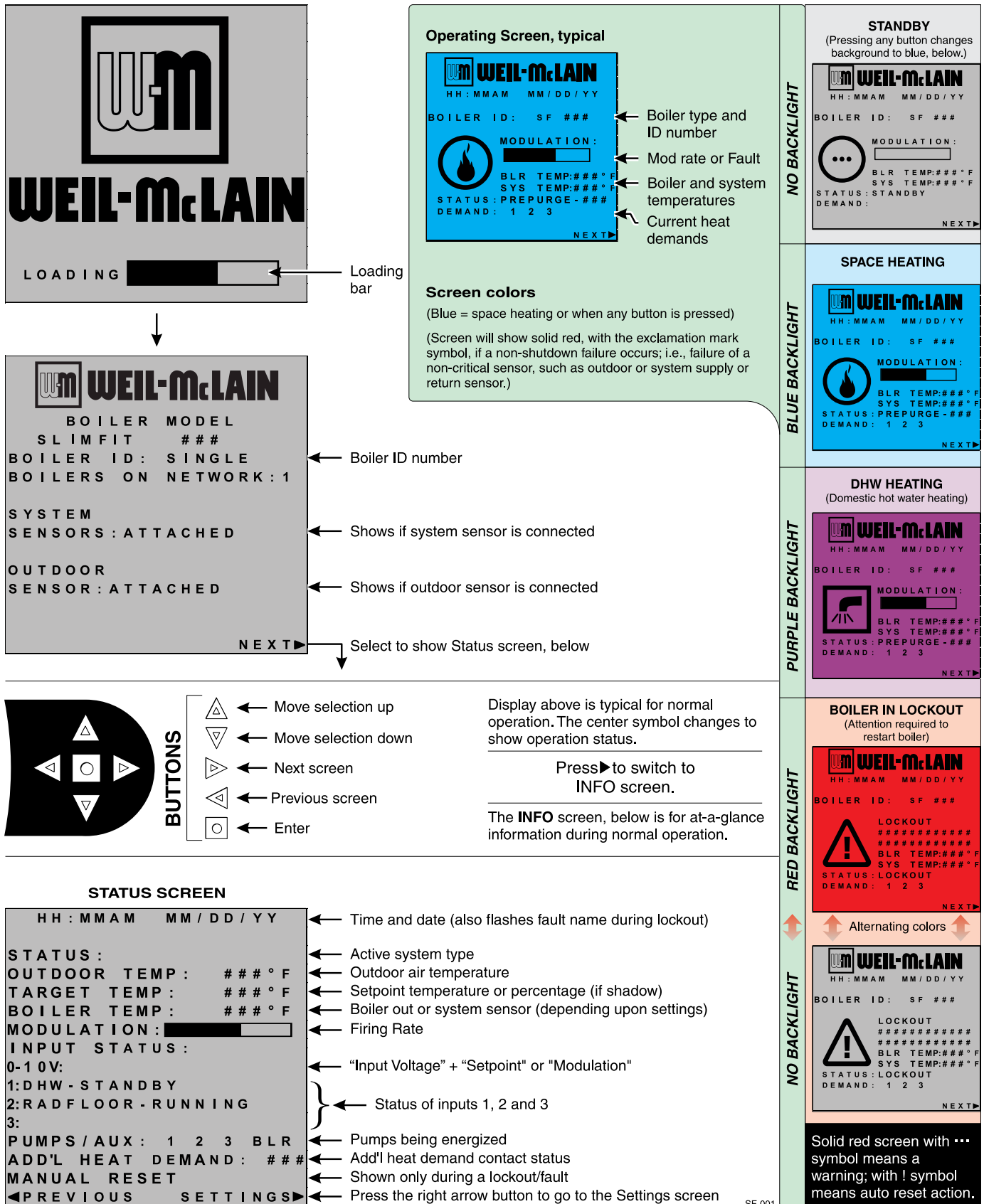



Control operation and setup *(continued)*

Figure 59 SlimFit control settings available in BASIC MODE (see Advanced Manual for ADVANCED MODE settings)

Available settings from CONTRACTOR MENU		
Boiler Settings Menu	Priority 2 menu	Assign Inputs menu
• Boiler Model	• Inputs Assigned (non-selectable)	Input 1: TT1
• Control Type	• System Type	• Priority 1, 2 or 3
• High Altitude	• Target Mod Sensor (non-selectable)	• Source (TT1 or 0-10v)
• LP Gas	• Target Adjust (non-selectable)	• AUX PUMP/OUTPUT
• Manual Reset High Limit Temp	• Supply Max	• Off
• WWSD Temp	• Supply Min (not available for DHW) *	
• Adjust Outdoor	• OD Reset Max (or Volts for Max) *	Input 2: TT2 and Input 3:TT3
• Circulator Exercising	• OD Reset Min (or Volts for Min) *	• Priority 1, 2 or 3
• Freeze Protect Circs	• Boost Time *	• AUX PUMP/OUTPUT
• Reset Factory Default		• Off
	Priority 3 menu	
	• Inputs Assigned (non-selectable)	Diagnostics menu
Priority 1 menu	• System Type	• See Figure 67, page 77 for details.
• Inputs Assigned (non-selectable)	• Target Mod Sensor (non-selectable)	
• System Type	• Target Adjust (non-selectable)	Maintenance Info menu
• Target Mod Sensor (non-selectable)	• Supply Max	• See Figure 72, page 82 for details.
• Target Adjust (non-selectable)	• Supply Min (not available for DHW) *	
• Supply Max	• OD Reset Max (or Volts for Max) *	Set Date and Time menu
• Supply Min (not available for DHW) *	• OD Reset Min (or Volts for Min) *	• See Figure 72, page 82 for details.
• OD Reset Max (or Volts for Max) *	• Boost Time *	
• OD Reset Min (or Volts for Min) *	* These items only appear in the menus if Target Adjust is active.	
• Boost Time *		

Figure 60 System types available in BASIC MODE (each option shown with factory settings)

System Type	8-Character Abbreviation	3-Character Abbreviation	Supply Max °F	OD Reset Min °F	Supply Min °F	OD Reset Max °F	Run Boiler Pump	Run AUX PUMP/ OUTPUT
Fan-coil	FAN-COIL	FCL	180	0	140	70	YES	YES
Finned Tube Baseboard	FIN BASE	FTB	180	0	130	70	YES	YES
Cast Iron Baseboard	IRONBASE	CIB	180	0	120	70	YES	YES
Cast Iron Radiators	RADIATOR	CIR	180	0	120	70	YES	YES
Radiant - slab on grade	RAD SLAB	RSG	120	0	80	70	YES	YES
Radiant - thin slab	RAD SLAB	RTS	140	0	80	70	YES	YES
Radiant - below floor (staple up)	RADFLOOR	RSU	160	0	90	70	YES	YES
Radiant - above floor (sleeper system)	RADFLOOR	RAF	140	0	90	70	YES	YES
Domestic Hot Water	DOMESTIC	DHW	180	N/A	N/A	N/A	NO	NO
Custom (user defined)	XXXXXXXX (user input)	first three of user input	180	0	70	70	YES	YES



CONTRACTOR menus

⚠ WARNING Boiler Model, Altitude and Fuel Type are critical settings. Failure to set correctly could result in severe personal injury, death or substantial property damage.

1. Access contractor menus by pressing and holding the UP and DOWN arrow keys at the same time for 7 seconds.
2. See the following pages for explanations of control setting options.

Figure 61 SlimFit control menu access — accessing contractor menus

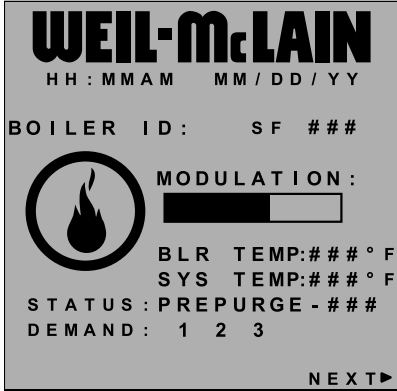

▲ + ▼ **Hold 7 secs**

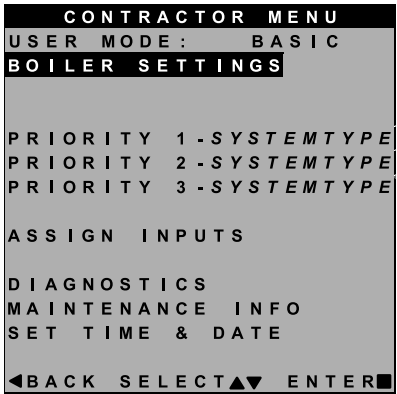

Highlight item, then press
◻ **to select**

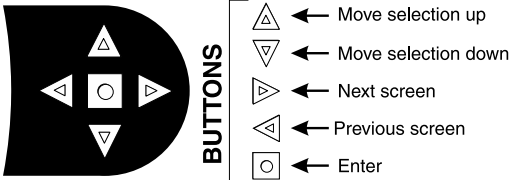

CONTROL NAVIGATION BUTTONS

MENU ITEM	PURPOSE	More information
USER MODE	<ul style="list-style-type: none"> The default for this setting is BASIC mode. Screens shown in this manual assume the USER MODE is set to BASIC. For advanced features available in ADVANCED mode, see the SlimFit Advanced Manual. 	
BOILER SETTINGS	<ul style="list-style-type: none"> Set/change boiler model, control type, high altitude setting, ODT sensor requirement, manual reset, high limit and WWSD temperature settings, outdoor sensor temp adjustment, circulator exercising, freeze protection setup, and restore to factory default option. 	See page 73
PRIORITY 1	<ul style="list-style-type: none"> These settings control operating temperatures and behaviors for systems that are assigned to “PRIORITY 1.” 	See page 74
PRIORITY 2	<ul style="list-style-type: none"> These settings control operating temperatures and behaviors for systems that are assigned to “PRIORITY 2.” 	See page 74
PRIORITY 3	<ul style="list-style-type: none"> These settings control operating temperatures and behaviors for systems that are assigned to “PRIORITY 3.” 	See page 74
ASSIGN INPUTS	<ul style="list-style-type: none"> These settings assign Priority 1, 2 or 3 to each of the three inputs to the control. 	See page 75
DIAGNOSTICS	<ul style="list-style-type: none"> Use to review current and historical information including previous lockouts. 	See page 77
MAINTENANCE INFO	<ul style="list-style-type: none"> Used to set contractor contact information, boiler information and maintenance dates. 	See page 82
SET TIME & DATE	<ul style="list-style-type: none"> Use to set date and time — important since fault occurrences are date/time stamped. 	None

Screens shown above are typical only. Actual screens depend on control settings chosen.



BOILER SETTINGS menu, BASIC mode

⚠WARNING Boiler Model, Altitude and Fuel Type are critical settings. Failure to set correctly could result in severe personal injury, death or substantial property damage.

1. Access contractor menus by pressing and holding the UP and DOWN arrow keys at the same time for 7 seconds.
2. See Figure 61, page 72 for the screen sequences up to the CONTRACTOR menu.

Figure 62 SlimFit BASIC mode BOILER SETTINGS options (USER MODE must be set to BASIC)

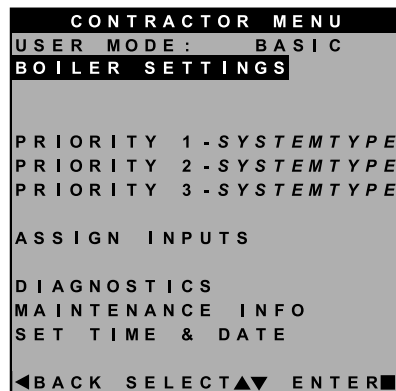

Highlight BOILER SETTINGS then press

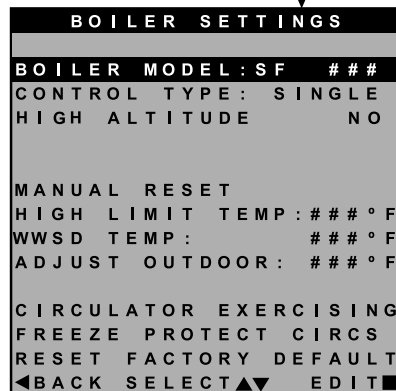

Highlight item, then press to select

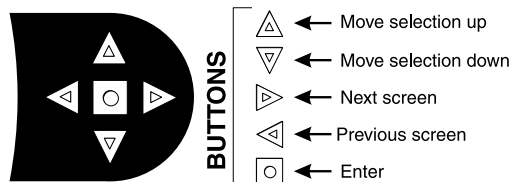

CONTROL NAVIGATION BUTTONS

SF-002b

MENU ITEM	DESCRIPTION
BOILER MODEL	<ul style="list-style-type: none"> • ⚠WARNING MUST be set to correct model. • Check the boiler model against the model listed on the boiler's rating plate. Change the selection to the correct model if not. Also verify the model number on the control display at power-up. Failure to correct would result in severe personal injury, death or substantial property damage.
CONTROL TYPE	<ul style="list-style-type: none"> • Select single, master or shadow. Must be set to Single for basic mode.
HIGH ALTITUDE	<ul style="list-style-type: none"> • ⚠WARNING If the boiler is installed at an altitude above 5500 feet, select YES for high altitude. The control will automatically adjust firing rates (blower speeds) to compensate for altitude. Altitude MUST be set correctly to avoid risk of severe personal injury, death or substantial property damage.
MANUAL RESET HIGH LIMIT TEMP	<ul style="list-style-type: none"> • If boiler outlet water temperature exceeds this temperature, the Control will shut down the boiler and enter lockout. Changing this setting is NOT recommended.
WWSD TEMP	<ul style="list-style-type: none"> • WWSD stands for warm weather shut down. It means the boiler will not be allowed to fire if the outside temperature is greater than the WWSD setting. When the boiler is kept off because the outside temperature is above WWSD, the graphic display will show WWSD, and the boiler will remain in standby until the outside temperature drops below WWSD temperature. WWSD does not apply to DHW systems. The outdoor sensor must be installed to use this function.
ADJUST OUTDOOR	<ul style="list-style-type: none"> • Use this setting to calibrate the outdoor sensor when needed to compensate for variations in lead length or other factors that could affect total resistance in sensor circuit.
CIRCULATOR EXERCISING	<ul style="list-style-type: none"> • For each circulator, select whether you want the control to automatically start the circulator and run for 10 seconds for each 72-hour period of inactivity.
FREEZE PROTECT CIRCS	<ul style="list-style-type: none"> • This function automatically fires the boiler at low fire and starts the circulators chosen if the heat exchanger sensors detect a temperature less than 45 °F. Burner is turned on if temperature drops below 40 °F. Circulators and burner turn off when the temperature rises above 48 °F.
RESET FACTORY DEFAULTS	<ul style="list-style-type: none"> • Use this function to restore all control settings to factory default values — will require complete restart and setup of control after resetting. Record information from the MAINTENANCE screen and any history information that may be of use in the future. ALL stored data is eliminated when reset to defaults except for boiler model number.

Screens shown above are typical only. Actual screens depend on control settings chosen.



PRIORITY 1, 2, 3 menus, BASIC mode

WARNING Boiler Model, Altitude and Fuel Type are critical settings. Failure to set correctly could result in severe personal injury, death or substantial property damage.

1. Access contractor menus by pressing and holding the UP and DOWN arrow keys at the same time for 7 seconds.
2. See Figure 61, page 72 for the screen sequences up to the CONTRACTOR menu.

Figure 63 SlimFit BASIC mode PRIORITY options (USER MODE must be set to BASIC)

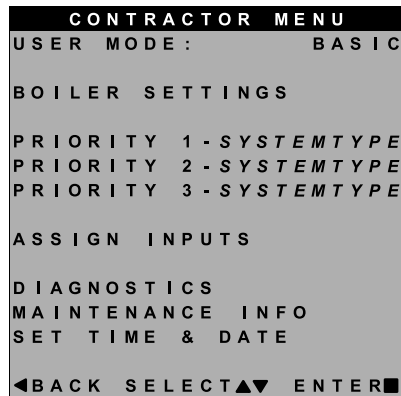

Highlight PRIORITY 1, 2 or 3 then press

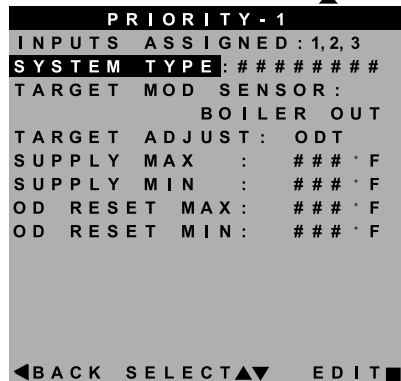

Highlight item, then press to select

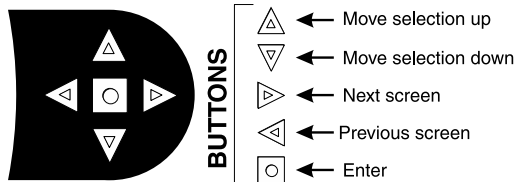

CONTROL NAVIGATION BUTTONS

SF-002c

MENU ITEM	DESCRIPTION
INPUTS ASSIGNED	<ul style="list-style-type: none"> • Lists all the inputs already assigned to this PRIORITY. Inputs will be listed as 1, 2, 3. • Shows NONE if there are no inputs assigned to this priority .
SYSTEM TYPE	<ul style="list-style-type: none"> • Select the system type for this PRIORITY, based on the heating terminal units in the system (see Figure 59, page 71). Use the CUSTOM selection to set the control for a different system type. The factory preset values for SUPPLY MAX, SUPPLY MIN, OD RESET MAX and OD RESET MIN are chosen based on the normal best setting for the terminal units.
TARGET MOD SENSOR	<ul style="list-style-type: none"> • Choose SYSTEM SUPPLY or BOILER OUT to determine which will be the primary temperature sensor. The control will modulate boiler input to reach the TARGET temperature. (Default is System Supply.) If system sensors are not used, boiler defaults to using heat exchanger outlet sensor in place of system sensor. • Not adjustable in Basic Mode, see Advanced Manual for information on adjusting this parameter.
TARGET ADJUST	<ul style="list-style-type: none"> • Select how target temperature is calculated by control: NONE (no reset, fixed target temperature), 0-10V (target temperature based on analog input from remote source), ODT (outdoor reset operation; default setting). • Not adjustable in Basic Mode, see Advanced Manual for information on adjusting this parameter.
SUPPLY MAX	<ul style="list-style-type: none"> • Set SUPPLY MAX to the required supply water temperature for the system at design maximum heat loss (typically 180 °F for finned tube baseboard on new installations.)
SUPPLY MIN	<ul style="list-style-type: none"> • SUPPLY MIN should equal the desired minimum supply water temperature for the system. • This line is not shown on priorities configured as DHW system type or Heating system type, if outdoor temperature sensor not used. See Advanced Manual for information on adjusting this parameter .
OD RESET MAX	<ul style="list-style-type: none"> • OD RESET MAX is the outdoor temperature at which the target temperature reaches its minimum (SUPPLY MIN). • This line is not shown on priorities configured as DHW system type or Heating system type, if outdoor temperature sensor not used. See Advanced Manual for information on adjusting this parameter .
OD RESET MIN	<ul style="list-style-type: none"> • OD RESET MIN means the outdoor temperature at which the target temperature reaches its maximum value (SUPPLY MAX). • OD RESET MIN should equal the ODT (outdoor design temperature) for the installation's location. • This line is not shown on priorities configured as DHW system type or Heating system type, if outdoor temperature sensor not used. See Advanced Manual for information on adjusting this parameter .

Screens shown above are typical only. Actual screens depend on control settings chosen.



ASSIGN INPUTS menu, BASIC mode

WARNING Boiler Model, Altitude and Fuel Type are critical settings. Failure to set correctly could result in severe personal injury, death or substantial property damage.

1. Access contractor menus by pressing and holding the UP and DOWN arrow keys at the same time for 7 seconds.
2. See Figure 61, page 72 for the screen sequences up to the CONTRACTOR menu.

Figure 64 SlimFit BASIC mode ASSIGN INPUT options (USER MODE must be set to BASIC) — see Figure 65, page 76 and Figure 66, page 76 for explanation of AUX PUMP/OUTPUT settings

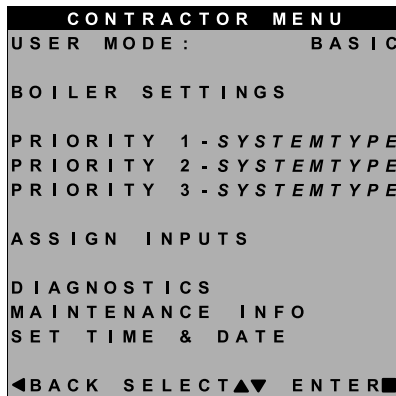

Highlight ASSIGN INPUTS then press

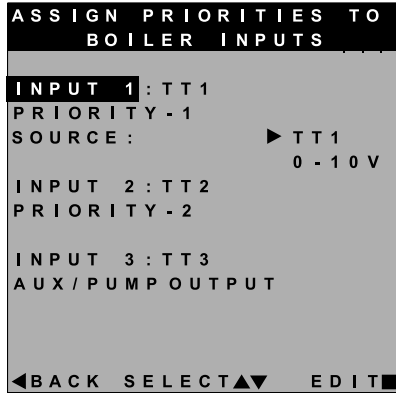

Highlight item, then press to select

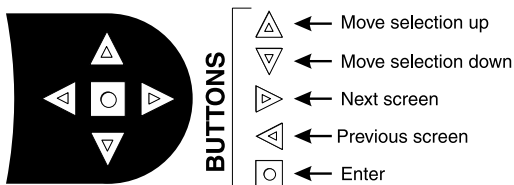

CONTROL NAVIGATION BUTTONS

SF-002db

MENU ITEM	DESCRIPTION
Overview	<ul style="list-style-type: none"> • There are three priority levels defined by the settings chosen in Figure 63, page 74. • For DHW priority, make sure PRIORITY 1 is defined for a DHW system. • If DHW priority is required and analog input is used for space heating, assign INPUT 2 to the DHW aquastat (TT2) and INPUT 1 as PRIORITY 2 and SOURCE set to 0-10V.
INPUT 1	<ul style="list-style-type: none"> • Assign priority (system type) for INPUT 1 — options are: • PRIORITY 1 — assigns INPUT 1 to PRIORITY 1 system. • PRIORITY 2 — assigns INPUT 1 to PRIORITY 2 system • PRIORITY 3 — assigns INPUT 1 to PRIORITY 3 system • AUX PUMP/OUTPUT • OFF • NOTE: For INPUT 1 only, select SOURCE = TT1 for thermostat input or 0-10V if analog input is required.
INPUT 2	<ul style="list-style-type: none"> • Assign priority (system type) for INPUT 2 — options are: • PRIORITY 1 — assigns INPUT 2 to PRIORITY 1 system. • PRIORITY 2 — assigns INPUT 2 to PRIORITY 2 system • PRIORITY 3 — assigns INPUT 2 to PRIORITY 3 system • AUX PUMP/OUTPUT • OFF
INPUT 3	<ul style="list-style-type: none"> • Assign priority (system type) for INPUT 3 — options are: • PRIORITY 1 — assigns INPUT 3 to PRIORITY 1 system. • PRIORITY 2 — assigns INPUT 3 to PRIORITY 2 system • PRIORITY 3 — assigns INPUT 3 to PRIORITY 3 system • AUX PUMP/OUTPUT • OFF

Screens shown above are typical only. Actual screens depend on control settings chosen.



ASSIGN INPUTS menu, BASIC mode *(continued)*

Figure 65 AUX PUMP/OUTPUT operation (accessed in ASSIGN INPUTS menu – see [Figure 64, page 75](#))

Option	Activation conditions	Suggested uses
ALWAYS ON	<ul style="list-style-type: none"> Output is always energized whenever the control is powered. 	<ul style="list-style-type: none"> Hot loop for seasonal boilers that are manually shut down at end of season and started up at start of heating season.
EXTERNAL SWITCH	<ul style="list-style-type: none"> The output is energized on closure of an external switch wired to this input and is de-energized when the external switch opens. 	<ul style="list-style-type: none"> Hot loop for boilers whose CH is manually shut down at end of season and started up at start of heating season, but remain available for local calls (DHW, etc.).
OUTDOOR BELOW WWSD	<ul style="list-style-type: none"> This output is energized only when outdoor temperature is below the WWSD setting (see BOILER SETTINGS menu, Figure 62, page 73). This setting is non-selectable if WWSD is set to OFF or ODT is not connected at initial boiler power. If Outdoor Below WWSD is already chosen and WWSD is later set to OFF, Outdoor Below WWSD will behave as Always On. 	<ul style="list-style-type: none"> Hot loop for boilers whose CH is automatically shut down based on outdoor temperature (inferred heat loss), but remain on for local calls (DHW, etc.).
ANY TT INPUT	<ul style="list-style-type: none"> The assigned output is energized if there is an input closure on this boiler. The assigned output will de-energize once there are; no input on this boiler, post-purge has finished, and post-pump time has expired. If the closed input is configured for a heat demand, its output will de-energize after post-purge and post-pump. 	<ul style="list-style-type: none"> Energize a system pump relay if pump must run during all heating calls.
ANY TT INPUT BY ITS PRIORITY SETTINGS	<ul style="list-style-type: none"> The assigned output is energized: <ul style="list-style-type: none"> If there is an input closure on this boiler. ... and ... RUN AUX PUMP/OUTPUT is set to YES for the priority assigned to the closed input. The assigned output will de-energize once there are; no input closures on any of the network boilers, post-purge has finished, and post-pump time has expired. 	<ul style="list-style-type: none"> Energize a system pump relay if pump must run only on some heat calls (such as systems with locally-connected DHW heating).
BURNER DEMAND	<ul style="list-style-type: none"> The assigned output is energized when the boiler receives a call for heat and starts to pre-purge. The assigned output is de-energized once the burner is off and post-purge is complete. 	<ul style="list-style-type: none"> Use for interlocking with combustion air damper, flow switch, etc.

Figure 66 AUX PUMP/OUTPUT operation — start, run and stop, based on boiler status

Option	Standby	TT Closed	Pre-Pump	Pre-Purge	Burner Running	Post-Purge	Post-Pump	Standby	Comments
ANY TT INPUT OR ANY TT INPUT BY ITS PRIORITY SETTINGS	off	ON	→					off	<ul style="list-style-type: none"> See Figure 65 for explanation of differences between the ANY TT INPUT options.
BURNER DEMAND	off	off	off	ON	→		off	off	



DIAGNOSTIC menu

Figure 67 DIAGNOSTICS menu navigation (see Figure 58, page 70 for access information)

Menus	Next screen	Next screen	Next screen	Next screen
<i>Follow information at the bottom of each screen to navigate to next/previous screen or enter/save data</i>				
DIAGNOSTICS	TEMPERATURES	STATUS: ##### BOILER OUT1: ### °F BOILER OUT2: ### °F HEAT EXCHANGER 1: ### °F HEAT EXCHANGER 2: ### °F BOILER IN: ### °F SYSTEM SUPPLY: ### °F SYSTEM RETURN: ### °F FROM SENSOR: ##### FLUE 1: ### °F FLUE 2: ### °F OUTDOOR TEMP: ### °F FROM SENSOR: #####		See following pages for details.
	INPUTS	STATUS: ##### INPUT1: ##### (8-character system type) INPUT2: ##### (8-character system type) INPUT3: ##### (8-character system type) 0-10V INPUT: #.#V LINKED TO MASTER: ### DEMAND OF MASTER: ### MANUAL LIMIT: ##### AUTO LIMIT: ##### LOW WTR CUTOFF: ##### AIR P-SWITCH: ##### GAS P-SWITCH: ##### CLOSURE SWITCH: ##### BLOWER SPEED: ####RPM FLAME SIGNAL: ###		See following pages for details.
	OUTPUTS	STATUS: ##### GAS VALVE: ### CIRC OUTPUT 1: ### CIRC OUTPUT 2: ### CIRC OUTPUT 3: ### BOILER CIRC: ### BLOWER SIGNAL: ###% ADD'L HEAT DEMANDS: ### ALARM: ### 0-10V OUTPUT: #.#V		See following pages for details.
	RUNTIME	BURNER TIME: ###HR ROTATE TIME: ###DAYS INPUT1 TIME: ###HR INPUT2 TIME: ###HR INPUT3 TIME: ###HR NETWORK TIME: ###HR IGNITION COUNT: ###		See following pages for details.
	MASTER-SHADOW COMM (shows on shadow boilers only)	Boiler ID: ##### Linked to Master: ### Boilers on Network: # Requested to Run: ### Type: #####-## Requested Mod Rate: ### Max Boiler Temp: ### °F Boiler ON Diff: ## °F Boiler OFF Diff: ## °F		See following pages for details.
	NETWORK BOILERS (shows on master boilers only)	Shows firing rate, boiler temperature, active priority, with system type and sequence order of all boilers on the network.		See following pages for details.



DIAGNOSTICS menu *(continued)*

Figure 68 DIAGNOSTICS menu navigation, continued (see [Figure 58, page 70](#) for access information)

Menus	Next screen	Next screen	Next screen	Next screen
Follow information at the bottom of each screen to navigate to next/previous screen or enter/save data				
DIAGNOSTICS <i>(cont.)</i>	NETWORK INPUTS (shows on master boilers only)	Shows input status of all network boiler inputs.		
	SOFTWARE VERSIONS	DISPLAY WM#.## MAIN MICRO WM#.## SECOND MICRO WM#.##	See following pages for details.	
	PAST ERRORS	CONTROL FAULTS: ### IGNITION RETRIES: ###	See following pages for details.	
		MANUAL RESET CNT: ###	See following pages for details.	
		AUTO RESET CNT: ###	See following pages for details.	
		LOCKOUT HISTORY 1 LOCKOUT HISTORY 2 LOCKOUT HISTORY 3	LOCKOUT HISTORY # FAULT NAME: #### FAULT TYPE: #### TIME: HH:MM AM DATE: MM/DD/YY STATUS: ####### TEMPERATURES INPUTS OUTPUTS	TEMPERATURES INPUT STATUS OUTPUT STATUS
MANUAL TEST MODE (Single boiler or network Shadow boiler)	STATUS: ####### HEAT EXCHANGER: ### TARGET: ### °F or “%” for network MODULATION: ####### BOILER OUT: ### °F BOILER IN: ### °F SYSTEM SUPPLY: ### °F SYSTEM RETURN: ### °F FLUE: ### °F OUTDOOR: ### °F BLOWER SIGNAL: ###% BLOWER SPEED: ###RPM FLAME SIGNAL: ### FORCE RATE: AUTO	See following pages for details.		
MANUAL RESET	PRESS ENTER TO RESET THE FOLLOWING ERROR (SCREEN SHOWS A LIST OF ERRORS)	See following pages for details.		



DIAGNOSTICS menu *(continued)*

Figure 69 DIAGNOSTICS menu details (see Figure 58, page 70 for access information)

Menu/Item	Comment
Temperatures	
Status	Current operating status of the boiler. Prepurge, Ignition, Name of the system Type being satisfied, post purge, Warm Weather Shut down, Trouble
Boiler Out1	Temperature of the first sensing element of the boiler's heat exchanger outlet sensor
Boiler Out2	Temperature of the second sensing element of the boiler's heat exchanger outlet sensor
Heat Exchanger 1:	Temperature of the first sensing element of the boiler's heat exchanger block outlet sensor
Heat Exchanger 2:	Temperature of the second sensing element of the boiler's heat exchanger block sensor
Boiler In	Temperature of the boiler's heat exchanger inlet sensor
System Supply	Temperature of the system water after the boiler loop
System Return	Temperature of the system water returning to the boiler loop
From Sensor	Displays where System Supply/Return values are being read from. Most relevant when using multiple sensors connected to the same Master Boiler Network. When Shadow boilers are connected, this will specify which boiler it is reading.
Flue1	Temperature of the first sensing element of the boiler's flue gas sensor
Flue2	Temperature of the second sensing element of the boiler's flue gas sensor
Outdoor	Temperature of the remote outdoor air temperature sensor
Inputs	
Status	Current operating status of the boiler. Prepurge, Ignition, Name of the system Type being satisfied, post purge, Warm Weather Shut down, Trouble
Input 1	Call for heat status on Input 1 (Input 1 can be TT1 or 0-10VDC input)
Input 2	Call for heat status on Input 2
Input 3	Call for heat status on Input 3
0 –10V Input	Voltage input for target adjust or modulation for single boiler
Linked to Master	For Multiple Boiler Networks. Shows if current control is connected to Master boiler
Demand of Master	For Multiple Boiler Networks. Shows if the Master boiler is calling this boiler heat demand
Manual Limit	External manual limit on low voltage terminal strip
Auto Limit	External auto limit on low voltage terminal strip
Low Wtr Cutoff	Low water cutoff device (inside boiler jacket)
Air P-Switch	Limit device (inside boiler jacket) that will shut off the boiler if flue pressure becomes too high
Gas P-Switch	Limit device that will shut off the boiler if gas pressure gets too high or low
Closure Switch	P7 jumper circuit closed or open (flow switch, CAD, etc.)
Blower Speed	Feedback from blower sensor
Flame Signal	Number indicating the presence and quality of the flame used to shut down or boost the boiler
Outputs	
Status	Current operating status of the boiler. Prepurge, Ignition, Name of the system Type being satisfied, post purge, Warm Weather Shut down, Trouble
Gas Valve	Control's gas valve circuit status
Circulator 1	Control's circulator 1 relay status
Circulator 2	Control's circulator 2 relay status
Circulator 3	Control's circulator 3 relay status
Boiler Circ 4	Boiler's circulator
Blower Signal	Control's signal controlling the blower speed
Additional Heat Demand	Additional heat demand contact status
Alarm	Alarm contact status
0 –10V Output	Voltage being output, by P16, pins 1 & 2



DIAGNOSTICS menu *(continued)*

Figure 70 DIAGNOSTICS menu details (continued) (see [Figure 58, page 70](#) for access information)

Menu/Item	Comment
Run Times	
Burner Time	Displays cumulative time the burner has been active (can be increased by user)
Rotate Time	Records the days of operation passed from the last time the Master boiler rotated the firing sequence.
Input 1 Time	Displays cumulative time that Input 1 has been closed (Or 0-10V \geq 1 volt)
Input 2 Time	Displays cumulative time that Input 2 has been closed
Input 3 Time	Displays cumulative time that Input 3 has been closed
Network Time	Records time this boiler was running on a network call for heat generated by the Master boiler
Ignition Count	Displays total number of successful ignitions
Master-Shadow Comm	
Boiler ID	Displays boiler control type and ID number
Linked to Master	Shows if control is currently linked to a Master control
Boilers on Network	Shows number of boilers currently on network
Requested to Run	Shows if this control is being requested to satisfy a network call
Type	Shows whether the control is Network-P1, Network-P2, or NONE
Requested Mod Rate	Rate coming from the Master
Max Boiler Temp	Displays maximum allowable boiler temperature
Boiler On Diff	Temperature differential from master boiler for network priorities
Boiler Off Diff	Temperature differential from master boiler for network priorities
Network Boilers	
For multiple boilers only – See SlimFit Advanced manual	
###%	Shows current rate of boiler
###F	Shows Boiler Out temperature of boiler
#####	Shows priority being satisfied, updated based on active demand
#####	Shows system type of call for heat, updated based on active demand
# OF #	Shows the sequence position of that boiler in all the boilers available
BLR#	Shows boiler number this data belongs to
Network Inputs	
Boiler number	Displays boiler number
Inputs	Displays input's configuration and whether it is active. If input is active, it will be displayed in BOLD print
Software Versions	
Display	Software version of the microprocessor on the display circuit board
Main Micro	Software version of the main microprocessor on the control circuit board
Second Micro	Software version of the second microprocessor on the control circuit board
TO RESET ALL HISTORY COUNTERS TO ZERO:	
PAST ERRORS	
Control Fault	Displays number of control faults
Ignition Retries	Displays cumulative ignition attempts. It is recommended that this be reset during yearly maintenance by holding down the Left and Right arrows or by selecting this line and pressing the Enter button
Manual Reset Cnt	Displays number of manual reset lockouts since last cleared
Auto Reset Cnt	Displays number of auto reset lockouts since last cleared
Lockout History 1	Choose this to view the most recent error recorded
Fault Name	Displays the name of the fault that occurred
Fault Type	Displays the type of fault that occurred



DIAGNOSTICS menu *(continued)*

Figure 71 DIAGNOSTICS menu details (continued) (see [Figure 58, page 70](#) for access information)

Menu/Item	Comment
Time	Displays time that lockout occurred
Date	Displays date that lockout occurred
Status	Displays what the status of the boiler was at the time of the error
Temperatures	Choose this to view the Boiler Temperatures at the time of the error
Inputs	Choose this to view the status of the Boiler Inputs at the time of the error
Outputs	Choose this to view the status of the Boiler Outputs at the time of the error
Lockout History 2	Choose this to view the second most recent error recorded
Fault Name	Displays the name of the fault that occurred
Fault Type	Displays the type of fault that occurred
Time	Displays time that lockout occurred
Date	Displays date that lockout occurred
Status	Displays what the status of the boiler was at the time of the error
Temperatures	Choose this to view the Boiler Temperatures at the time of the error
Inputs	Choose this to view the status of the Boiler Inputs at the time of the error
Outputs	Choose this to view the status of the Boiler Outputs at the time of the error
Lockout History 3	Choose this to view the third most recent error recorded
Fault Name	Displays the name of the fault that occurred
Fault Type	Displays the type of fault that occurred
Time	Displays time that lockout occurred
Date	Displays date that lockout occurred
Status	Displays what the status of the boiler was at the time of the error
Temperatures	Choose this to view the Boiler Temperatures at the time of the error
Inputs	Choose this to view the status of the Boiler Inputs at the time of the error
Outputs	Choose this to view the status of the Boiler Outputs at the time of the error

Manual Test Mode	
Status	Current operating status of the boiler. Prepurge, Ignition, Name of the system Type being satisfied, post purge, Warm Weather Shut down, Trouble
Heat Exchanger	Temperature of the heat exchanger block sensor
Target	Calculated target temperature based on outdoor temp or the max target if no ODR
Modulation	Displays what sensor the boiler is using to modulate from. If the boiler is being self-limited, this may also display what the cause is
Boiler Out	Temperature of the outlet sensor on the boiler heat exchanger
Boiler In	Temperature of the inlet sensor on the boiler heat exchanger
System Supply	Temperature of the system water after the boiler loop
System Return	Temperature of the system water returning to the boiler loop
Flue	Temperature of flue gases
Outdoor	Temperature of outdoor air
Blower Signal	Control's signal controlling the blower speed
Blower Speed	Blower's feedback to the control
Flame Signal	Number indicating the presence and quality of the flame used to shut down or boost the boiler
Force Rate	Used to manually force a rate during a call for heat. Choose auto for normal operation
Manual Reset	
	Reset selected condition



MAINTENANCE, DATE AND TIME menus

Figure 72 MAINTENANCE, DATE AND TIME menus — navigation (see Figure 58, page 70 for access information)

Maintenance Info	Comment
Name	Contractor name to appear in maintenance reminders and during lockouts
Phone	Contractor phone number
Model	Displays the boiler model selected in the boiler setup
CP Number	Enter the CP# of the boiler
Installed	Enter the date the boiler was installed
Last Date	Date automatically entered when Reset Reminder is chosen by contractor
Next Date	Date automatically calculated when Reset Reminder is selected by contractor
Interval Settings	Contractor selects maintenance reminder frequency based on service history
Reset Reminder	Contractor selects this to update Last maintenance Date and Next Date. Homeowner uses this to ignore the reminder and update only the Next Date.

Set Time and Date	
Year	Set year (homeowner or contractor)
Month	Set month (homeowner or contractor)
Day	Set day (homeowner or contractor)
Hour	Set hour (homeowner or contractor)
Minute	Set minute (homeowner or contractor)

MAINTENANCE INFO

Use this section to enter contractor's information, CP number, install date and to enter an automatic notice for maintenance (default is 12 months). Because this shows on the display, it is an automatic means of notifying the homeowner of need for scheduled maintenance by the technician. Select RESET REMINDER to reset for the next maintenance date.

SET TIME AND DATE

Enter current date and time. This allows correct maintenance reminder timing and provides date and time stamp for lockout histories on ERROR screen in Diagnostic Menu.



Startup — fill the system

Clean system to remove sediment

1. You must thoroughly flush the system (without boiler connected) to remove sediment. The high-efficiency heat exchanger can be damaged by buildup or corrosion due to sediment.
2. If necessary, use an approved chemical cleaning agent, following the manufacturer's guidelines for procedures. A list of approved cleaning products is available at www.weil-mclain.com. See **Replacement parts, starting on page 108** for Weil-McLain part numbers to obtain cleaning agents through a WM Technologies distributor.
3. For zoned systems, flush each zone separately through a purge valve. (If purge valves and isolation valves are not already installed, install them to properly clean the system.)
4. Flush system until water runs clean and you are sure piping is free of sediment.

▲WARNING

Do not use petroleum-based cleaning or sealing compounds in boiler system. Damage to elastomer seals and gaskets in system could occur, resulting in substantial property damage.

Before filling the boiler and system with water, verify the following. **DO NOT fill with softened water.** Boiler corrosion can occur.

Failure to comply could result in boiler failure or unreliable operation.

Water chemistry

Water pH between 7.0 and 8.5

1. Maintain boiler water pH between 7.0 and 8.5. Check with litmus paper or have chemically analyzed by water treatment company.
2. If pH differs from above, consult local water treatment company for treatment needed.
3. Softened water maybe used to fill boiler providing Sentinel X100 is added to the system at the proper dosage and properly maintained. Without Sentinel X100, softened water **must not** be used or boiler corrosion may occur.

Hardness must be less than 7 grains

Consult local water treatment companies for unusually hard water areas (above 7 grains hardness).

Chlorine concentration must be LESS THAN 200 ppm

1. Filling with chlorinated fresh water should be acceptable since drinking water chlorine levels are typically less than 5 ppm.
2. Do not use the boiler to directly heat swimming pool or spa water.
3. Do not fill boiler or operate with water containing chlorine in excess of 200 ppm.

Antifreeze

1. Use only antifreeze listed by WM Technologies as suitable for use with SlimFit Gas Boilers. A list of approved antifreeze products is available at www.weil-mclain.com.
2. See **Replacement parts, starting on page 108** for Weil-McLain part numbers to obtain antifreeze through a WM Technologies distributor.

Use the correct amount of antifreeze

1. Determine the freezing temperature needed (to protect against lowest likely temperature the system water will encounter).
2. Find the antifreeze concentration by volume needed for this temperature from the antifreeze manufacturer's data on the antifreeze container. **DO NOT** exceed 50% by volume concentration of antifreeze.
3. Add up the volume (gallons) of all system piping and components, including the expansion tank and boiler.
 - a. Boiler water content is listed on [page 121](#).
 - b. Remember to include expansion tank water content.
4. Multiply this volume by the (percent) antifreeze needed to find the number of gallons of antifreeze to add.

Fill and test water system

1. Fill system only after ensuring the water meets the requirements of this manual.
2. Close manual and automatic air vents and boiler drain valve.
3. Fill to correct system pressure. Correct pressure will vary with each application.
 - a. Pressure will rise when boiler is turned on and system water temperature increases. Operating pressure must never exceed 80 psig.
4. At initial fill and during boiler startup and testing, check system thoroughly for any leaks. Repair all leaks before proceeding further.

▲WARNING

Eliminate all system leaks. Continual fresh make-up water will reduce boiler life. Minerals can build up in sections, reducing heat transfer, overheating heat exchanger, and causing heat exchanger failure.

Purge air from water system

1. Connect a hose to the purge valve (see purge/drain valves, item 11, in piping diagrams beginning on [page 14](#)). Route hose to an area where water can drain and be seen.
2. Close the boiler or system isolation valve between the purge valve and fill connection to the system.
3. Close zone isolation valves.
4. Open quick-fill valve on cold water make-up line.
5. Open purge valve.
6. One zone at a time, open the isolation valves. Allow water to run through the zone, pushing out the air. Run until no noticeable air flow is present. Close the zone isolation valves and proceed with the next zone. Follow this procedure until all zones are purged.



Startup — fill the system *(continued)*

Freeze protection (when used)

▲WARNING Follow these guidelines to prevent possibility of severe personal injury, death or substantial property damage:

NEVER use automotive or standard glycol antifreeze, even glycol made for hydronic systems. Use only freeze-prevention fluids recommended by WM Technologies for application in SlimFit Boiler systems.

Thoroughly flush any system that has used glycol before installing the new SlimFit boiler.

Review the material safety data sheet (MSDS) for the fluid used with the boiler owner and leave a copy for reference. The MSDS contains information on potential hazards and first aid procedures for exposure or ingestion.

Check antifreeze inhibitor level at least annually. Glycol concentration and inhibitor levels may change over time. Add antifreeze to increase concentration if necessary. Add inhibitor as needed to bring to acceptable level, using inhibitor test kit to verify.

When using freeze protection fluid with automatic fill, **install a water meter to monitor water make-up.** Freeze protection fluid may leak before the water begins to leak, causing concentration to drop, reducing the freeze protection level.

DO NOT exceed 50% antifreeze by volume. Antifreeze moves more sluggishly than water and can interfere with heat transfer. At antifreeze concentrations higher than 50%, sludge can develop in the boiler, potentially causing damage to the heat exchanger.

Clean the system before filling. Always drain and flush the system thoroughly before filling with antifreeze. Sludge, iron oxide deposits and other sediment in the system inhibit flow and can cause rapid breakdown of inhibitors.

Use only antifreeze recommended by WM Technologies.

NOTICE WM Technologies provides information for application of the antifreeze products listed in this document only for use in Weil-McLain SlimFit boilers. Do not apply these products or instructions for other applications. Local codes may require a backflow preventer or actual disconnection from city water supply.

7. Close the quick-fill water valve and purge valve and remove the hose. Open all isolation valves. Watch that system pressure rises to correct cold-fill pressure.
8. After the system has operated for a while, eliminate any residual air by using the manual air vents located throughout the system.
9. If purge valves are not installed in system, open manual air vents in system one at a time, beginning with lowest floor. Close vent when water squirts out. Repeat with remaining vents.
10. Open automatic air vent (diaphragm-type or bladder-type expansion tank systems only) one turn.
11. Starting on the lowest floor, open air vents one at a time until water squirts out.
12. Repeat with remaining vents.
13. Refill to correct pressure.

▲WARNING X100 inhibitor is recommended

1. It is recommended that the SlimFit boiler have Sentinel X100 added to the system to prevent damage to the boilers' heat exchanger. See [Replacement parts, starting on page 108](#) for re-ordering information.
2. After filling the system as directed in these instructions, use a caulking gun to inject the X100 inhibitor concentrate into the system, or fill with the X100 in its liquid form, following the instructions on the tube or container.
3. After adding the inhibitor to the system, allow time for the water to circulate and mix. Then check the inhibitor level. Add additional inhibitor if necessary.
4. See separate instructions or www.weil-mclain.com for suggested guidelines to determine how much inhibitor to use.

Check/verify water chemistry

1. The system may have residual substances that could affect water chemistry.
2. After the system has been filled and leak tested, verify water pH and chlorine concentrations are acceptable.
3. Verify antifreeze concentration, when used.
4. Follow the instructions on the Sentinel test kit to sample the system water and verify inhibitor concentration.

Check inhibitor and antifreeze concentrations annually

1. Test the pH of a sample of system water at least annually. The pH of the water mixture must be between 7.0 and 8.5. (Or use the Sentinel inhibitor test kit to check concentration.)
2. If pH is outside this range (or inhibitor test kit indicates low level), the inhibitor level may not be sufficient to prevent corrosion.
3. Test antifreeze concentration.

▲WARNING Test antifreeze concentration at least annually. If concentration is low, add antifreeze or drain system and refill with correct mixture. Follow instructions on [page 83](#) to determine amount of antifreeze needed.

4. Check inhibitor level after adjustments are made.



Startup — final checks

Check for gas leaks

▲WARNING Before starting the boiler, and during initial operation, use a leak detector or smell near the floor and around the boiler for gas odorant or any unusual odor. Remove boiler front door and smell interior of boiler enclosure. Do not proceed with startup if there is any indication of a gas leak. Repair any leak at once.

DO NOT adjust or attempt to measure gas valve outlet pressure. The gas valve is factory-set for the correct outlet pressure. This setting is suitable for natural gas and propane, requiring no field adjustment. Attempting to alter or measure the gas valve outlet pressure could result in damage to the valve, causing potential severe personal injury, death or substantial property damage.

Propane boilers only — Your propane supplier mixes an odorant with the propane to make its presence detectable. In some instances, the odorant can fade, and the gas may no longer have an odor. Before startup (and periodically thereafter), have the propane supplier verify the correct odorant level in the gas.

Check thermostat circuit(s)

1. Disconnect the two external wires connected to the boiler thermostat terminals (see Field wiring, beginning on [page 50](#) for terminal locations).
2. Connect a voltmeter across these two incoming wires. Close each thermostat, zone valve and relay in the external circuit one at a time and check the voltmeter reading across the incoming wires.
3. There should NEVER be a voltage reading.
4. If a voltage does occur under any condition, check and correct the external wiring. (This is a common problem when using 3-wire zone valves.)
5. Once the external thermostat circuit wiring is checked and corrected if necessary, reconnect the external thermostat circuit wires. Allow the boiler to cycle.

Inspect/fill condensate system

Inspect/check condensate lines and fittings

1. Inspect the condensate drain line, condensate PVC fittings and condensate trap. (See [page 46](#) for component locations.)
2. Pour water into the top of the boiler's 1" PVC condensate tee and check for any leaks in the condensate drain line or fittings. Repair any leaks.

Fill condensate trap with water

1. Remove boiler front door.
2. Remove the flue inspection plug (item 45, [page 3](#)).
3. Pour fresh water into the flue inspection opening until the condensate trap is full of water (water begins to flow out through condensate drain tee).

4. Replace the flue inspection plug.

▲WARNING The condensate trap must be filled with water during all times of boiler operation to avoid flue gas emission from the condensate drain line. Failure to fill the trap could result in severe personal injury or death.

Final checks before starting boiler

- Read the instructions to adjust and set up the Control module.
- Verify that the boiler model is set correctly in the Control, and that it displays correctly.
- Verify that the boiler and system are full of water and all system components are correctly set for operation.
- Fill condensate trap with water (see above for procedure).
- Verify electrical connections are correct and securely attached.
- Inspect vent piping and air piping for signs of deterioration from corrosion, physical damage or sagging. Verify air piping and vent piping are intact and correctly installed per this manual.

To start the boiler

1. Turn OFF the boiler ON/OFF switch.
2. Read and follow the Operating Instructions, [Figure 75, page 88](#).
3. The Control display will show installed sensors when first powered. Make sure the right sensors are detected. If not, determine the cause and correct before proceeding.

If boiler does not start correctly

1. Check for loose connections, blown fuse or service switch off?
2. Is external limit control (if used) open? Is boiler water temperature above 200 °F?
3. Is thermostat set below room temperature?
4. Is gas turned on at meter or boiler?
5. Is incoming gas pressure greater or less than required on [page 49](#) (natural gas) or (propane)?
6. Are parameters set correctly as per this manual?
7. Is the warm weather shutdown activated?
8. If none of the above corrects the problem, refer to Troubleshooting, beginning on [page 96](#).

Check system and boiler

Check water piping

1. Check system piping for leaks. If found, shut down boiler and repair immediately. (See **WARNING** on [page 83](#) regarding failure to repair leaks.)
2. Vent any remaining air from system using manual vents. Air in the system will interfere with circulation and cause heat distribution problems and noise.



Startup — final checks *(continued)*

☐ Check vent piping and air piping

Check for gas-tight seal at every connection and seam of air piping and vent piping.

▲WARNING Venting system must be sealed gas-tight to prevent flue gas spillage and carbon monoxide emissions which will result in severe personal injury or death.

☐ Check gas piping

Check around the boiler for gas odor following the procedure of page 48 of this manual.

▲WARNING If you discover evidence of any gas leak, shut down the boiler at once. Find the leak source with bubble test and repair immediately. Do not start boiler again until corrected. Failure to comply could result in severe personal injury, death or substantial property damage.

☐ Propane boilers — verify conversion

Verify propane orifice has been installed per Propane Conversion instructions.

▲WARNING DO NOT adjust or attempt to measure gas valve outlet pressure. The gas valve is factory-set for the correct outlet pressure. This setting is suitable for natural gas and propane, requiring no field adjustment. Attempting to alter or measure the gas valve outlet pressure could result in damage to the valve, causing potential severe personal injury, death or substantial property damage.

SlimFit boilers are shipped ready to fire natural gas ONLY. You must install the propane orifice if the boiler will be connected to propane. See page 9. Failure to comply could result in severe personal injury, death or substantial property damage.

☐ Check flame & combustion with instruments

1. Initiate a call for heat on one of the heat demand inputs.
2. Access the Control installer menus by pressing and holding the UP and DOWN arrow keys for five seconds.
3. Use the Control display to navigate DIAGNOSTICS to Manual test mode (see page 95 for proper instructions on forcing rates during Manual Test Mode) and force the firing rate to High (high fire).
4. Look at the flame through the flame inspection window. The high fire flame should be blue and should be stable. The burner surface should be covered with orange dots.
5. Remove the flue temperature sensor from the flue pipe and insert a combustion test probe., using a calibrated combustion test instrument.
6. Test for CO₂ (or O₂) and for CO. The CO₂ values must be within 1% of the values listed in Figure 73. If results are acceptable, proceed to step 7. IF NOT, follow the instructions under Gas valve adjustment procedure, page 87 to set the CO₂ values. See WARNING in next column.

▲WARNING If combustion at either high or low fire is outside the range given in Figure 73, follow the procedure given for adjusting the throttle screw on the gas valve. If throttle screw adjustment does not correct the problem, then shut down the boiler and contact your local WM Technologies representative. Throttle screw adjustment must be done only by a qualified technician, using calibrated test instruments. Failure to comply could result in severe personal injury, death or substantial property damage.

Figure 73 Acceptable CO₂ and CO values (CO₂ must be within 1.0% of these values)

Boiler	Fuel	High fire		Low fire	
		%CO ₂	CO ppm	%CO ₂	CO ppm
SF-550	NG	9.2	< 60	9.0	< 60
	LP	10.1	< 60	9.9	< 60
SF-750	NG	9.2	< 60	9.0	< 60
	LP	10.1	< 60	10.1	< 60

These values are for altitudes up to 5,500 feet. For higher altitudes, CO₂ may be slightly lower and CO slightly higher.

1. Measure natural gas input:
 - a. Operate boiler 10 minutes.
 - b. Turn off other appliances.
 - c. At natural gas meter, measure time (in seconds) required to use one cubic foot of gas.
 - d. Calculate gas input:

$$\frac{3600 \times 1000}{\text{number of seconds from step c}} = \text{Btuh}$$
 - e. Btuh calculated should approximate input rating on boiler rating label.
2. Use the Control display to navigate to Manual test mode (see Figure 68, page 78) and force the firing rate to Low (low fire).
3. Look at the flame through the flame inspection window. The low fire flame should be stable and evenly distributed over burner surface with a uniform orange color.
4. Repeat the combustion test of steps 5 and 6 above.
5. Use the Control display to navigate to Manual test mode (see Figure 68, page 78) and force the firing rate to AUTO (normal operation).
6. Re-install the flue gas temperature sensor.

▲WARNING You must re-install the flue gas temperature sensor to prevent flue gas spillage into the boiler enclosure. Failure to comply could result in severe personal injury, death or substantial property damage.

Startup — final checks *(continued)*

Gas valve adjustment procedure

⚠ WARNING DO NOT attempt to adjust the gas valve settings unless you are a qualified technician, and with the use of calibrated combustion test instruments. Adjust the valve settings only as needed to meet the combustion values given in [Figure 73, page 86](#).

1. This procedure is only necessary when combustion tests indicate the need, as explained under [□ Check flame & combustion with instruments, page 86](#)
2. Boiler behavior that might indicate a need to check combustion values at high fire (as per [page 86](#)) to verify boiler is in adjustment include: difficulty igniting, poor flame stability at low fire, combustion noise or high carbon monoxide values.
3. Combustion readings must be taken at both high fire and low fire.

Adjust valve at high fire

Use the Control display to navigate to Manual test mode (see [Figure 68, page 78](#)) and force the firing rate to High (high fire). (See [page 95](#) for proper instructions on forcing rates during Manual Test Mode). After the boiler has had time to stabilize and high-fire RPM value (see [Figure 78, page 95](#)) is reached, take a CO₂ reading.

- a. See [Figure 74](#) to adjust if necessary.
- b. Remove the blue cover on the throttle screw opening with a straight-bit screwdriver.

NOTICE

Make only small (1/8-turn) throttle screw adjustments. Adjustment can be sensitive, especially on propane. Navigate to DIAGNOSTICS — Manual test mode (see [page 95](#) for proper instructions on testing).

If the CO₂ is HIGH, turn the throttle screw CLOCKWISE to lower the input. Allow the boiler to stabilize and take another reading. Continue until the desired CO₂ value is achieved.

- c. If the CO₂ is LOW, turn the throttle screw COUNTER-CLOCKWISE to increase the input. Allow the boiler to stabilize and take another reading. Continue until the desired CO₂ value is achieved.
- d. Re-install the blue cover on the gas valve.

Adjust valve at low fire

1. Lock the boiler into low fire using the Control module screen. Verify that the blower rpm value is correct for low fire (see [Figure 78, page 95](#)).
2. Check the combustion readings.
3. If results are acceptable at low fire, verify high fire readings again. Restore firing rate to AUTO.
4. If combustion results are not acceptable, remove the cover screw over the offset adjustment (see [Figure 74](#)). Navigate to DIAGNOSTICS — Manual test mode (see [page 95](#) for proper instructions on testing).
5. Use a T40 Torx driver to adjust the setting. Rotate clockwise to increase CO₂, rotate counterclockwise to decrease CO₂. Re-install the cover screw when completed.
6. Consult your local WM Technologies representative if acceptable results cannot be obtained for both high and low fire.

Figure 74 Throttle screw location (ONLY for use by a qualified technician, using calibrated combustion test instruments)

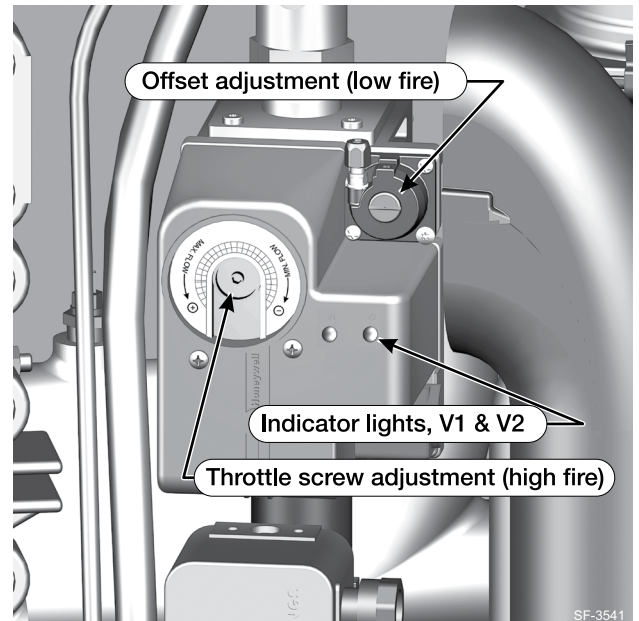

□ Adjust and test boiler controls

Follow instructions in this manual to set and verify operation of the boiler controls.

□ Check ignition system safety shutoff device

1. After the boiler has been installed, turn off the boiler.
2. Shut off the manual gas valve located on the gas line to stop flow of fuel to the boiler.
3. Turn on the boiler. It will start the ignition sequence, but will not light. After some time, the boiler will lockout, the display screen will turn red, and the Control will flash “Ignition Fault”. It means that the boiler tried to ignite without success for five (5) times and went into Lockout mode. This means that the ignition system safety device worked properly.
4. Clear the Lockout condition by selecting “Manual Reset” in the Diagnostic Menu.
5. Open the manual gas valve located on the gas line to resume fuel supply to the boiler.

Operating Instructions

Figure 75 Operating instructions (WARNING — Verify that the Control is set for the correct boiler model before proceeding.)

**FOR YOUR SAFETY
READ BEFORE OPERATING**

WARNING

If you do not follow these instructions exactly, a fire or explosion may result causing property damage, personal injury or loss of life.

A. This appliance does not have a pilot. It is equipped with an ignition device which automatically lights the burner. Do not try to light the burner by hand.

B. Before OPERATING, smell all around the appliance area for gas. Be sure to smell next to the floor because some gas is heavier than air and will settle on the floor. See below.

C. Use only your hand to turn the gas control knob. Never use tools. If the knob will not turn by hand, don't try to repair it, call a qualified service technician. Force or attempted repair may result in a fire or explosion.

D. Do not use this appliance if any part has been under water. Immediately call a qualified service technician to inspect the appliance and to replace any part of the control system and any gas control, which has been under water.

WHAT TO DO IF YOU SMELL GAS

- Do not try to light any appliance.
- Do not touch any electric switch; do not use any phone in your building.

- Immediately call your gas supplier from a neighbor's phone. Follow the gas supplier's instructions.
- If you cannot reach your gas supplier, call the fire department.

OPERATING INSTRUCTIONS

1. Stop! Read the safety information at left on this label. This appliance is equipped with an ignition device which automatically lights the burner. Do not try to light the burner by hand.
2. Set room thermostat(s) to lowest setting. Verify external manual gas cock is open (valve handle parallel to gas piping).
3. Turn OFF all electrical power to the appliance.
4. Rotate two rotary latches at top of access door counterclockwise to release door.
5. Remove boiler access door by tilting forward and lifting up.
6. Turn boiler manual gas valve knob counterclockwise ↶ to open gas supply.
7. Wait five (5) minutes to clear out any gas. Then smell for gas, including near the floor. If you smell gas, STOP! Follow "B" in the safety information to the left. If you don't smell gas, go to the next step.
8. Turn ON all electrical power to the appliance.
9. Set thermostat(s) to desired setting.
10. The display will show symbols and text describing the status of the boiler as it proceeds through its operating sequence. "Standby" status means there is no call for heat. A faucet or flame symbol on the display means the boiler is firing.

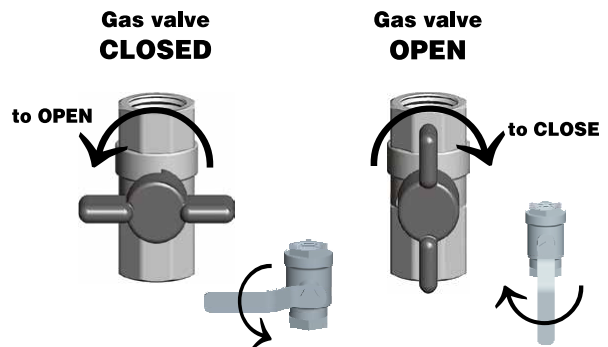

11. If the appliance will not operate when there is a call for heat and piping is not hot, follow the instructions "To Turn Off Gas To Appliance" below and call your service technician or gas supplier.
12. Reinstall jacket front panel. Make sure panel is seated firmly in place and all joints are visually sealed. Then tighten the two thumb screws at bottom of access door firmly.

TO TURN OFF GAS TO THE APPLIANCE

1. Set room thermostats to lowest setting.
2. Turn OFF all electrical power to the appliance.
3. Close external manual gas cock (valve handle perpendicular to gas piping). Remove boiler access door. Turn boiler manual gas valve knob clockwise ↷ to close gas supply.
4. Reinstall boiler access door.



550-101-255 (0116)

Check-out/startup verification

NOTICE Fill out start-up data on the Installation and Service Certificate, [page 123](#).

- Verified that the Control is set for the correct boiler model?
- Boiler and heat distribution units filled with water?
- Water chemistry verified per [page 83](#)?
- Automatic air vents, if used, open one full turn?
- Air purged from system?
- Air purged from gas piping? Piping checked for leaks?
- Primed condensate trap?
- Propane conversion kit installed for propane firing and propane conversion label affixed to jacket?

WARNING SlimFit boilers are shipped ready to fire natural gas ONLY. You must install the propane conversion kit if the boiler will be connected to propane. See [page 8](#). Failure to comply could result in severe personal injury, death or substantial property damage.

- Thermostat circuit wiring checked to ensure there are no stray voltages?
- Followed Operating Instructions, [Figure 75, page 88](#)
- Burner flame and combustion verified per [page 86](#)?
- Verified control operation for space heating and DHW (if used) per this manual?
- Tested additional field-installed controls — If boiler has additional limits, have they been tested for operation as outlined by manufacturer? (Boiler should be operating and should go off when controls are tested. Verify controls cause automatic reset lockout or manual reset lockout as desired.)
- Set additional field-installed limit control(s) to system temperature requirements? Adjusted balancing valves and controls to provide design temperature to system?
- For multiple zones, adjusted for correct flow in each zone?
- Verified thermostat heat anticipator (if available) set properly (see [page 63](#) for requirements)?
- Cycled boiler with thermostat (and with DHW aquastat, if installed) — Raised to highest setting and verified boiler goes through normal startup cycle? Lowered to lowest setting and verified boiler goes off?
- Measured natural gas input? ([page 86](#))
- Checked incoming gas pressure as specified on [page 49](#) (natural gas) or (propane).
- Observed several operating cycles for proper operation.
- Set room thermostat to desired room temperature (and DHW aquastat, if installed, to desired DHW storage temperature)?
- Reviewed all instructions shipped with this boiler with owner or maintenance person?
- Fill in **Installation certificate** on [page 123](#).
- Fill out the warranty registration card and send to WM Technologies.
- Return instructions to envelope and give to owner or place inside boiler housing.

Gas valve leakage testing

WARNING DO NOT connect a manometer to the manual gas valve or the automatic gas valve. The high vacuum from the blower could pull fluid into the gas line, possibly damaging the gas valves.

1. Refer to the gas valve manufacturer's instructions for the procedure to test the valve.
2. To operate the two valve solenoids independently, navigate to the Valve Test Screen on the Control (see [Figure 67, page 77](#) for access sequence).
3. When in the Gas Valve Test Screen, you will see two options:
 - a. Open Gas Valve 1
 - b. Open Gas Valve 2
4. To open only gas valve 1, highlight it and press enter/save.
5. While still in the Gas Valve test screen, give the boiler a call for heat. The boiler will go through its normal Ignition sequence, but will only open Gas Valve 1.
6. After gas valve 1 has opened, end the call for heat.
7. This procedure can be repeated by selecting and entering Open Gas Valve 2.
8. After the testing is complete and the call for heat has been removed, use the back button to exit the Gas Valve Test Screen. This will then reset the control to open both Gas Valves for any call for heat.

Figure 76 Gas valve test pressure tapings

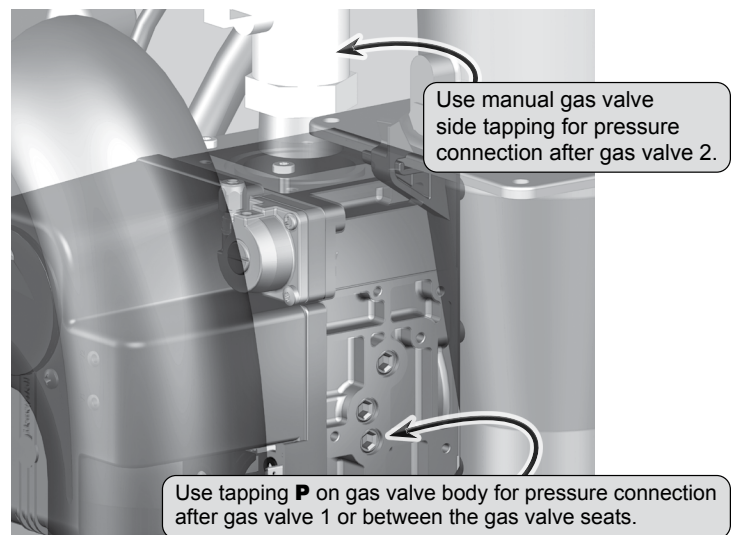

Gas pressure switch settings

After testing the gas pressure switches, restore the settings to the following:

- a. High gas pressure switch — 14" w.c.
- b. Low gas pressure switch — 2" w.c.

WARNING Install a 100% lockup gas pressure regulator in the gas supply line if inlet pressure can exceed 14" w.c. at any time. Adjust the lockup regulator for 7 to 10" w.c. inlet pressure. This setting provides a cushion below the setting of the high gas pressure switch. Failure to comply could result in shutdown by the high gas pressure switch, resulting in possible serious property damage due to freeze-up.



Annual startup and general maintenance

Figure 77 Service and maintenance schedules

Service technician (see following pages for instructions)		Owner maintenance (see SlimFit User's Information Manual for instructions)		
ANNUAL START-UP (See First-year special inspection)	General:			
	Reported problems.	Daily	<ul style="list-style-type: none"> • Check boiler area. • Check air openings. • Check pressure/temperature gauge. • Verify boiler front door is securely in place. 	
	Inspect interior; clean and vacuum if necessary; WARNING — no solvents.		Monthly	<ul style="list-style-type: none"> • Check vent piping. • Check air piping. • Check relief valve. • Check condensate drain system. • Check automatic air vents (if used).
	Clean base collector and condensate trap and fill with fresh water.		Periodically	<ul style="list-style-type: none"> • Test low water cutoff by pressing test button.
	Check for leaks (water, gas, flue, condensate).		Every 6 months	<ul style="list-style-type: none"> • Check boiler piping (gas and water). • Operate relief valve.
Check system water chemistry, inhibitor level and antifreeze concentration, if used.			End of season	<ul style="list-style-type: none"> • Shut boiler down (unless boiler used for domestic water).
Verify flue and air lines in good condition and sealed tight.				
Check system water pressure/system piping/expansion tank.				
Check control settings.				
Ignition electrode (clean with steel wool and reposition).				
Ignition and ground wiring.				
Wiring and connections.				
Perform start-up checkout and performance verification beginning with <u>Startup — fill the system, page 83</u> .				
Flame inspection (stable, uniform).				
Flame signal (see <u>Figure 81, page 94</u>).				
Clean heat exchanger if flue temp is more than 54°F above return water temp.				
Inspect jacket front door gaskets; replace if necessary.				
Additional if combustion or performance indicate need:				
Clean heat exchanger.				
Remove and clean burner using compressed air only.				
Vacuum the blower.				
Review:				
Review with owner.				

⚠ WARNING Follow the service and maintenance procedures given throughout this manual and in component literature shipped with the boiler. Failure to perform the service and maintenance could result in damage to the boiler or system. Failure to follow the directions in this manual and component literature could result in severe personal injury, death or substantial property damage.

Annual startup

HANDLING CERAMIC FIBER MATERIALS

REMOVAL OF SIGHT GLASS GASKET

▲WARNING The sight glass gasket in this product contains ceramic fiber materials that have been identified as carcinogenic, or possibly carcinogenic, to humans. Ceramic fibers can be converted to cristobalite in very high temperature applications. The International Agency for Research on Cancer (IARC) has concluded, “Crystalline silica inhaled in the form of quartz or cristobalite from occupational sources is carcinogenic to humans (Group 1).”:

- Avoid breathing dust and contact with skin and eyes.
 - Use NIOSH certified dust respirator (N95). This type of respirator is based on the OSHA requirements for cristobalite at the time this document was written. Other types of respirators may be needed depending on the job site conditions. Current NIOSH recommendations can be found on the NIOSH web site at <http://www.cdc.gov/niosh/homepage.html>. NIOSH approved respirators, manufacturers, and phone numbers are also listed on this web site.
 - Wear long-sleeved, loose fitting clothing, gloves, and eye protection.
- Apply enough water to the sight glass gasket to prevent airborne dust.
- Remove sight glass gasket from the boiler and place it in a plastic bag for disposal.
- Wash potentially contaminated clothes separately from other clothing. Rinse clothes washer thoroughly.

NIOSH stated First Aid

- Eye: Irrigate immediately
- Breathing: Fresh air.

FIRST-YEAR SPECIAL INSPECTION

1. **No later than 12 months** after the boiler is installed, perform a first-year inspection of the boiler. This must include the following **in addition to routine annual start-up procedures**.
 - a. Remove the heat exchanger cover plate. Inspect the heat exchanger and clean if necessary. See instructions for removing and replacing the heat exchanger cover plate, and for cleaning the heat exchanger, in the Maintenance section of this manual.
 - b. Make sure the burner is clean.
 - c. Make sure the burner gasket is in good condition. Replace if necessary.
 - d. Disconnect condensate trap and drain lines. Inspect, then flush thoroughly.
2. Determine follow-up maintenance and service needs based on the condition of the heat exchanger and condensate lines.
 - a. If the heat exchanger shows substantial fouling, or if condensate lines show accumulation of sediment, schedule a follow-up service call to perform the first-year inspection again, sooner than the normal twelve months between.
 - b. Heavy fouling of the exchanger or condensate lines indicates possible combustion air contamination. Inspect the air intake area carefully, and remove possible contaminants. See [Figure 12](#), page 22, for products to avoid.

▲WARNING You must eliminate causes of corrosion and contamination to ensure reliable operation of the boiler and system.



Annual startup *(continued)*

▲WARNING The boiler should be inspected and started annually, at the beginning of the heating season, only by a qualified service technician. In addition, the maintenance and care of the boiler designated in [Figure 77, page 90](#) and explained on the following pages must be performed to assure maximum boiler efficiency and reliability. Failure to service and maintain the boiler and system could result in equipment failure.

▲WARNING Electrical shock hazard — Turn off power to the boiler before any service operation on the boiler except as noted otherwise in this instruction manual. Failure to turn off electrical power could result in electrical shock, causing severe personal injury or death.

Address reported problems

Inspect any problems reported by owner and correct before proceeding.

Inspect boiler area

1. Verify that boiler area is free of any combustible materials, gasoline and other flammable vapors and liquids.
2. Verify that air intake area is free of any of the contaminants listed on [page 22](#) of this manual. If any of these are present in the boiler intake air vicinity, they must be removed. If they cannot be removed, reinstall the air and vent lines per this manual and the SlimFit Boiler Vent Supplement.

Inspect boiler interior & door gaskets

1. Remove front door and inspect interior of boiler.
2. Visually inspect the door gaskets. Make sure all are in good condition. Obtain replacements if any gasket is damaged.

▲WARNING Door gaskets must be intact, and must provide a reliable seal. Replace any damaged gasket.

3. Remove the venturi air inlet silencer and clean if necessary. Replace silencer.
4. Vacuum any sediment from the inside of the boiler and components. Remove any obstructions.

▲WARNING Do not use solvents to clean any of the boiler components. The components could be damaged, resulting in unreliable or unsafe operation.

Clean condensate trap

1. Remove flue inspection plug (item 45, [page 3](#)).
2. Inspect base collector with flash light. Flush out with water as needed.
3. Loosen condensate trap line hose clamps and remove trap line.
4. Empty water from trap line and inspect. Flush out if needed with fresh water.

5. Check condensate fittings and condensate line to drain. Flush if necessary to clean.
6. Reinstall condensate trap line and tighten hose clamps.
7. Fill trap with fresh water by pouring into flue inspection plug opening.
8. Replace flue inspection plug.

Check all piping for leaks

▲WARNING Eliminate all system or boiler leaks. Continual fresh make-up water will reduce boiler life. Minerals can build up in sections, reducing heat transfer, overheating heat exchanger, and causing heat exchanger failure. Leaking water may also cause severe property damage.

1. Inspect all water and gas piping and verify to be leak free.
2. Look for signs of leaking lines and correct any problems found.
3. Check gas line using procedure on [page 48](#).

Check air openings

1. Verify that combustion and ventilation air openings to the boiler room and/or building are open and unobstructed. Check operation and wiring of automatic combustion air dampers, if used.
2. Verify that boiler vent discharge and air intake are clean and free of obstructions.

Flue vent system and combustion air piping

Visually inspect entire flue gas venting system (and air piping, if installed) for blockage, deterioration or leakage. Repair any joints that show signs of leakage in accordance with vent manufacturer's instructions. When air is ducted to boiler, verify that air inlet pipe is connected and properly sealed.

▲WARNING Failure to inspect for the above conditions and have them repaired can result in severe personal injury or death.

Check water system

1. Verify all system components are correctly installed and operational.
2. Check the cold fill pressure for the system. Verify it is correct (usually around 12 psig).
3. Watch the system pressure as the boiler heats up (during testing) to ensure pressure doesn't rise too high. Excessive pressure rise indicates expansion tank sizing or performance problem.
4. Inspect automatic air vents and air separators. Remove air vent caps and briefly press push valve to flush vent. Reinstall caps. Make sure vents do not leak. Replace any leaking vents.
5. Check system water chemistry (inhibitor concentration, pH and hardness). See [page 83](#).



Annual startup *(continued)*

Check expansion tank

- Expansion tanks provide space for water to move in and out as the heating system water expands due to temperature increase or contracts as the water cools. Tanks may be open, closed or diaphragm or bladder type. See pages 14-19, of this manual for suggested best location of expansion tanks and air eliminators.
 - Open-type — located above highest radiator or baseboard unit, usually in the attic or closet. Has a gauge glass and overflow pipe to a drain.
 - Closed-type — welded gas tight and located above boiler. Tank is partially filled with water, leaving an air cushion for expansion.
 - Make sure this type of tank is fitted with a tank fitting, such as the B & G Tank-Trol or Taco Taco-Trol. This fitting reduces gravity circulation of air-saturated tank water back to the system and prevents the air from bubbling up through the water as it returns from the system.
 - Do not use automatic air vents in systems with closed-type tanks. The air will escape from the system instead of returning to the tank. Eventually, the tank will waterlog and no longer control pressurization. The boiler relief valve will weep frequently.
 - Diaphragm- or bladder-type** — welded gas tight with a rubber membrane to separate the tank pressurizing air and the water. May be located at any point in the system, but most often found near the boiler.
 - Systems with this type of expansion tank require at least one automatic air vent, preferably located on top of an air eliminator, as shown in examples in this manual.
- If relief valve has tended to weep frequently, the expansion tank may be waterlogged or undersized.
 - Closed-type tank** — tank is most likely waterlogged. Install a tank fitting if not already installed. Then check fill level per fitting manufacturer's instructions. If fill level is correct, check tank size against manufacturer's instructions. Replace with a larger tank if necessary.
 - Diaphragm- or bladder-type** — first, check tank size to be sure it is large enough for the system. If size is too small, add additional tank (or tanks) as necessary to provide sufficient expansion. If tank size is large enough, remove tank from system and check charge pressure (usually 12 psig for residential applications). If tank won't hold pressure, membrane has been damaged. Replace tank.

Inspect ignition electrode

- Remove the ignition electrode from the boiler heat exchanger.
- Remove any white oxides accumulated on the ignition electrode using steel wool. If the ignition electrode cannot be cleaned satisfactorily, replace ignitor with a new one.
- Reinstall ignition electrode, making sure gasket is in good condition and correctly positioned.
- Replace gasket if necessary.
- Make sure the ignition electrode ground wire is under the top screw that secures the ignitor to the casting.

Check ignition wiring

- Check ignition cable electrical resistance. A good cable will have resistance between 900 and 1000 ohms. Replace if not acceptable.
- Inspect boiler ground wire from ignition electrode to ground terminal strip.
- Verify all wiring is in good condition and securely attached.
- Check ground continuity of wiring using continuity meter.
- Replace ground wires if results are not satisfactory.

Check all boiler wiring

Inspect all boiler wiring, making sure wires are in good condition and securely attached.

Check control settings

- Use the Control display to navigate through all settings. Adjust settings if necessary.
- Check settings of external limit controls (if any) and adjust if necessary.

Perform startup and checks

- Start boiler and perform checks and tests specified in this manual.
- Verify cold fill pressure is correct and that operating pressure does not go too high.
- Complete the check-out procedure on [page 89](#).

Annual startup *(continued)*

Check burner flame *(See Figure 79)*

WARNING The boiler contains ceramic fiber materials. Use care when handling these materials per instructions on [page 91](#) of this manual. Failure to comply could result in severe personal injury.

1. Inspect flame through the observation window using the procedure on [page 86](#).
 - a. The high fire flame should be blue and should be stable. The burner surface should be covered with orange dots.
 - b. The low fire flame should be stable and evenly distributed over burner surface with a uniform orange color.
2. If the flame is unsatisfactory at either high fire or low fire, perform the testing specified on [page 86](#). If the problem remains, turn off the boiler and allow the boiler to cool down.
3. To access the burner, first turn off all power to the boiler:
 - a. Disconnect the two wire harnesses connected to the blower.
 - b. Use a 13-mm socket wrench to remove the three nuts that secure the mixing tube to the right-end heat exchanger section ([Figure 79](#)).
 - c. The mixing tube, blower, venturi and gas train can be pulled to the right to clear the mounting stud, then pulled forward and placed on a support while working. (If necessary, disconnect the ignitor ground wire and the wire harnesses to the gas valve and gas pressure switches.)
4. Remove the burner gasket and burner (see [Figure 80](#)).
5. Clean the burner ports both inside and outside surfaces, using a vacuum cleaner or compressed air. If necessary, use a soft-bristled brush to loosen particles.

WARNING Do not use compressed air unless doing so outside and wearing eye protection.

6. To replace the burner:
 - a. Insert the burner first. When inserting, place your hand inside the burner throat and tilt the back end of the burner up until the burner flange meets the heat exchanger. This is necessary to prevent the burner from rubbing on the heat exchanger burner support stubs on the left end section.
 - b. Align the burner flange notch with the notch in the casting above the burner opening.
 - c. Inspect the burner gasket. It must be in good condition. If not, replace with a new gasket (see [Replacement parts, starting on page 108](#)).
 - d. Place the gasket over the three studs.

NOTICE The burner-opening studs are unevenly spaced to ensure the gasket and the mixing tube are properly positioned.

7. Position the mixing tube over the studs. Replace the three nuts. Tighten securely (to 12 N-m/106 in-lbs/8.8 ft-lbs).
8. Reconnect any wiring that was disconnected.
9. Retest the boiler, making sure the flame is acceptable after the cleaning.

Check flame signal

1. Navigate to Diagnostics/Inputs on the Control display (see [Figure 67, page 77](#)). The flame signal value must be at least 20 above the Shutdown values given in [Figure 81](#).
2. If the flame signal drops to less than 20 above the Shutdown values, the Control will attempt to correct by increasing the boiler firing rate to increase flame signal.

Figure 79 Burner access

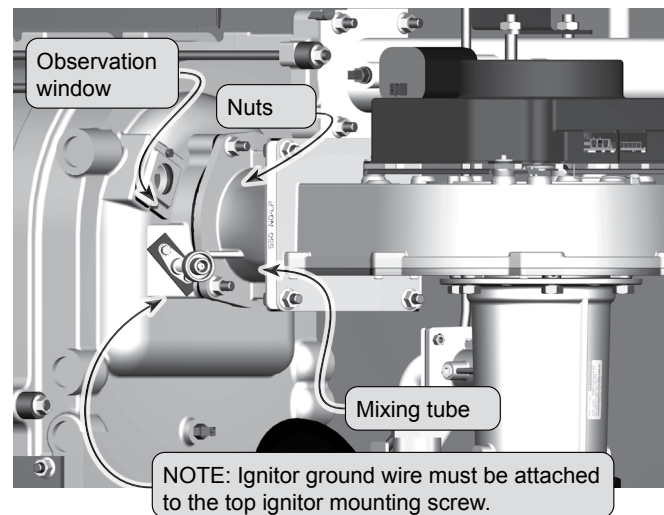

Figure 80 Burner removal and replacement

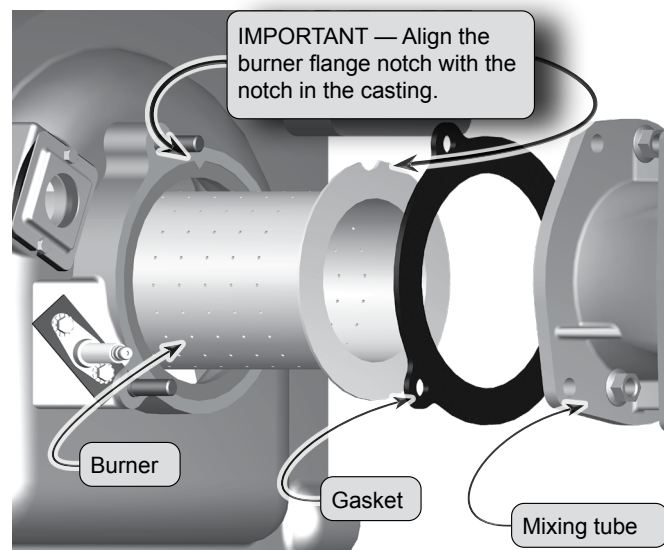

Figure 81 Flame signal shutdown values

Model SlimFit –	Shutdown flame signal	Restore flame signal
550	110	130
750	110	130

3. A lower flame signal may indicate a fouled ignitor or damaged ignitor insulation. If cleaning the ignitor does not improve, ground wiring is in good condition, and ground continuity is satisfactory, replace the ignitor.
4. If flame signal still remains low, inspect the vent and air piping. Then inspect the heat exchanger, following the procedures given in this manual for removal and reinstallation of the heat exchanger cover plate and other boiler components. Clean the heat exchanger as described in this manual if necessary.



Annual startup *(continued)*

Check flue gas temperature

1. Set the boiler to high fire. Then adjust the Control module display to view flue gas temperature and boiler return temperature.
2. The flue gas temperature should be no more than 54 °F higher than the boiler return temperature.
3. If the flue temperature is higher than this, shut down the boiler, allow to cool, and follow the procedure starting on [page 105](#) to clean the heat exchanger.

Check blower speeds

1. For installations at altitudes above 5,500 feet, make sure the control is set up for high altitude in the boiler setup menu. The Control module automatically adjusts low fire and ignition rates to compensate for high altitude conditions.
2. For installations below 5,500 feet, DO NOT enable high altitude.
3. Use the Control display to navigate to Manual test mode (see [Figure 68, page 78](#)).
4. Set the firing rate to Low (low fire).
5. Write down the blower RPM value shown and compare to the value in the table below. Low fire rate (and corresponding blower speed) is adjusted in the boiler setup menu.
6. Set the firing rate to MEDIUM (ignition rate).
7. Write down the blower RPM value. It should be within 200 RPM of the value listed in the table below.
8. Set the firing rate to High (high fire).
9. Write down the blower RPM value. It should be within 200 RPM of the value given in the table below.
10. If any of the values are outside the ranges listed in the previous steps, contact the factory for technical assistance.

Figure 78 Blower speeds for altitudes up to 5,500 feet (factory setting) and high altitude (over 5,500 ft)

Model SlimFit –	Low fire		Ignition		High fire	
	Factory setting	High altitude	Factory setting	High altitude	Factory setting	Maximum setting
550	1300	1900	2500	2800	5725	5950
750	1300	1825	2350	2650	5275	5500

Manual Test Mode for Single and Multiple Boilers

Single Boiler

1. Navigate to Manual Test Mode screen under DIAGNOSTICS menu.
2. Generate a call for heat and wait until the burner is lit, if not yet in operation.
3. Press ENTER and select the desired FORCE RATE. Rate will be forced to setting for 10 minutes.

Multiple Boiler Running

1. Generate a call for heat on a Network Priority or a Local Priority
 - a. Local Priority—allows Force Rate only on the boiler with the call for heat. Follow Single Boiler procedure, above.
 - b. Network Priority—allows Force Rate on any boiler in the network. Follow procedure outline below in steps 2-5.
2. On the Master boiler, navigate to Manual Test Mode screen under DIAGNOSTICS menu. Select desired boiler to be tested.
3. The Manual Test Mode screen will automatically appear on the boiler you selected. On the selected boiler's control, press ENTER and select the desired FORCE RATE (HIGH, MED, OR LOW).

CAUTION

When forcing a rate on a Network Priority call, only boilers running Local Priority calls will remain on. All other boilers on the network will not fire until the Manual Test has ended. Ensure critical applications remain heated. Long periods of low heating can cause property damage.

4. The selected boiler will run at the forced rate until it is either returned to AUTO, the user selects “End Manual Test” on the Master's Manual Test Mode screen, or after 30 minutes of inactivity on the Master control.
5. To test the next boiler, return to the master and select the next desired boiler to test.

Check boiler relief valve

1. Inspect the relief valve and lift the lever to verify flow as in the following warnings, excerpted from a relief valve manufacturer's warning label. Before operating any relief valve, ensure that it is piped with its discharge in a safe area to avoid severe scald potential. Read [Install water piping, page 12](#), before proceeding further.

WARNING

Safety relief valves should be reinspected AT LEAST ONCE EVERY THREE YEARS, by a licensed plumbing contractor or authorized inspection agency, to ensure that the product has not been affected by corrosive water conditions and to ensure that the valve and discharge line have not been altered or tampered with illegally. Certain naturally occurring conditions may corrode the valve or its components over time, rendering the valve inoperative. Such conditions are not detectable unless the valve and its components are physically removed and inspected. This inspection must only be conducted by a plumbing contractor or authorized inspection agency — not by the owner. Failure to reinspect the boiler relief valve as directed could result in unsafe pressure buildup, which can result in severe personal injury, death or substantial property damage.

Following installation, the valve lever must be operated AT LEAST ONCE A YEAR to ensure that waterways are clear. Certain naturally occurring mineral deposits may adhere to the valve, rendering it inoperative. When manually operating the lever, water will discharge and precautions must be taken to avoid contact with hot water and to avoid water damage. Before operating lever, check to see that a discharge line is connected to this valve directing the flow of hot water from the valve to a proper place of disposal. Otherwise severe personal injury may result. If no water flows, valve is inoperative. Shut down boiler until a new relief valve has been installed.

2. If the relief valve weeps or will not seat properly, replace the relief valve. Ensure that the reason for relief valve weeping is the valve and not over-pressurization of the system due to expansion tank waterlogging or undersizing.

Review with owner

1. Review the User's Information Manual with the owner.
2. Emphasize the need to perform the maintenance schedule specified in the User's Information Manual (and in this manual as well).
3. Remind the owner of the need to call a licensed contractor should the boiler or system exhibit any unusual behavior.
4. Remind the owner to follow the proper shutdown procedure and to schedule an annual startup at the beginning of the next heating season.



Troubleshooting

VERIFY PROPER OPERATION AFTER SERVICING.

CAUTION Before servicing and making connections . . . **ALWAYS TURN POWER OFF TO THE BOILER TO PREVENT ELECTRICAL SURGES, WHICH CAN DAMAGE BOILER COMPONENTS.**

WARNING **ELECTRICAL SHOCK HAZARD** — The boiler ON/OFF switch does not turn off all power to the boiler. **TURN OFF ALL POWER TO THE BOILER WHEN SERVICING.** Internal wiring is still powered when the switch is off.

CAUTION Label all wires prior to disconnection when servicing controls. Wiring errors can cause improper and dangerous operation. Always disconnect power to boiler before servicing. Failure to comply could result in severe personal injury, death or substantial property damage.

WARNING Never jumper (bypass) any device except for momentary testing. Severe personal injury, death or substantial property damage can result.

NOTICE
Before calling, always complete the “SlimFit Gas Data Collection Sheet” (page 124). Record the boiler size and Consumer Protection (CP) number (located on the left side of the control box, shown at right).

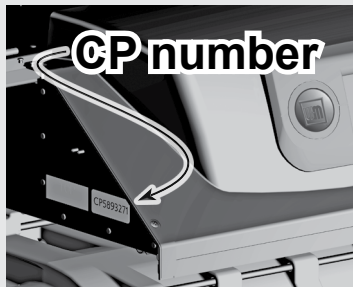

Reinstall boiler jacket front door

WARNING Reinstall boiler jacket front door after servicing. The boiler front door must be securely fastened to the boiler to prevent boiler from drawing air from inside the boiler room. This is particularly important if the boiler is located in the same room as other appliances. Failure to keep the door securely fastened could result in severe personal injury or death.

Before troubleshooting:

1. See Figure 82 for tools recommended for troubleshooting SlimFit boilers.
2. Check for 120 VAC (minimum 102 VAC to maximum 132 VAC) to boiler.
3. Check the Control’s last three lockout histories.
 - a. See [Figure 68, page 78](#) for access information.
 - b. Scroll down to DIAGNOSTICS and press the enter key.
 - c. Scroll down to PAST ERRORS and press the enter key.
 - d. Record the first four data records and then highlight the history record you want to view.
 - e. Follow information at the bottom of the screen to navigate through your lockout histories.

Figure 82 Tools for troubleshooting

Tools needed for troubleshooting	Purpose
#2 Phillips Screwdriver	Remove 4 screws to remove the top front cover
Control Screwdriver or 1/16" flat blade screwdriver	Used for wiring on terminal blocks for the Control (comes with boiler)
3/16" Allen Wrench (Hex Key)	To remove gas valve pressure tap plugs
3/8" Wrench	To remove gas pressure tap plug
13 mm Nut driver/ratchet	To remove the heat exchanger cover plate, mixing tube or blower
3 mm Allen wrench (Hex Key)	To adjust gas valve throttle
4 mm Allen wrench (Hex Key)	To add orifice to change from natural to propane
5 mm Allen wrench (Hex Key)	To disassemble venturi from blower (blower plate access)
13 mm wrench	To access combustion system and heat exchanger assembly, blower or mixing tube
Multimeter	To take measurement readings on sensors and electrical components
Manometer (Incline or digital)	To measure the gas pressure coming to the boiler.
Combustion analyzer (Digital preferred)	For combustion testing.
Contact thermometer	For checking surface temperatures of heat exchanger and pipes
T40 torx	For gas valve offset adjustment
8 mm wrench	For gas piping to venturi



Troubleshooting *(continued)*

Check the following:

1. Make sure heat demand is calling for heat and contacts (including appropriate zone controls) are closed. Check for 24 VAC between thermostat wire nuts and ground.
2. Make sure all external limit controls are either installed (and closed) or temporarily jumpered for testing.
3. Make sure that connectors to control module are securely plugged in at module and originating control.
4. Gas pressures as specified on [page 49](#) (natural gas) or (propane).

Always check Control module fuses

⚠WARNING ALWAYS check control module fuses before replacing control module or any major components (blower, etc.). If one of these fuses is blown, it can prevent control module or other components from operating.

1. Turn OFF power to boiler at external line switch.
2. Remove jacket door and jacket top panel. Rotate the swing-away control panel forward to expose the Control module and Expansion module.
3. Remove and inspect the two (2) Control fuses and the Expansion module fuse (located as shown below).

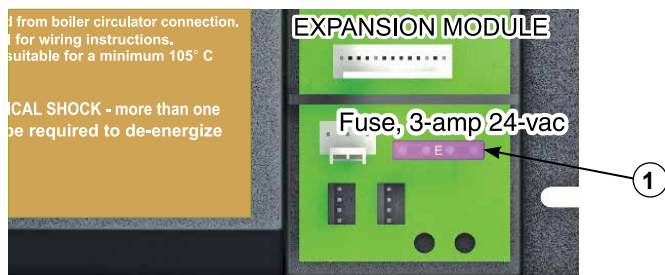
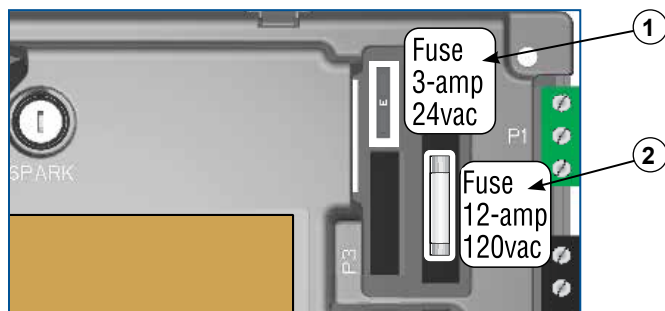

4. If necessary, replace the fuse:
 - a. Item 1 - Low voltage circuit fuse is a 3-amp fast-blow (Littelfuse 0287003).
 - b. Item 2 - Line voltage circuit fuse is a 12-amp fast-blow (Littelfuse 0314012 MXP or Bussman ABC-12-R).

⚠WARNING Do not jumper fuse or replace with any fuse except as specified. Failure to comply could result in severe personal injury, death or substantial property damage.

5. Reinstall jacket top panel and boiler jacket door after checking the fuses.
6. Restore power to boiler at external line switch and verify boiler operation after completing boiler service.

Checking temperature sensors

1. The boiler temperature sensors (flue, outdoor, boiler out, boiler in, heat exchanger and system) are all resistance-type devices.
2. Figure 83 shows the correct value for the sensor at various temperatures.
3. Use the resistance values at 32°F, 60°F, 70°F and 212°F to measure the sensor resistance at known temperatures (freezing point, room temperature and sea level boiling point). For freezing point and boiling point, insert the sensor in water at that temperature. Use an ohmmeter to read resistance value.
4. To check whether the control module is correctly sensing temperature, you can use a resistance decade box. Connect the decade box temporarily in place of a sensor and read the corresponding temperature on the Control display. The temperature should be close to the value corresponding to the input resistance.

Figure 83 Sensor resistance values

Sensor resistance values					
Temp (°F)	Sensor ohms		Temp (°F)	Sensor ohms	
	Min	Max		Min	Max
32	34265	37871	120	4517	4992
40	27834	30764	130	3698	4088
50	21630	23907	140	3043	3364
60	16944	18727	150	2517	2782
70	13372	14780	160	2091	2311
80	10629	11747	170	1744	1928
90	8504	9399	180	1461	1615
100	6847	7568	190	1229	1359
110	5545	6129	200	1038	1147



Troubleshooting *(continued)*

WARNING Make sure to determine the causes of outages. Do not leave the boiler operating without a complete diagnosis.

Control fault indications

1. The Control provides diagnostic information for both automatic reset conditions and manual reset conditions. See [Figure 58, page 70](#) for information available on the Control display.
2. Figure 84 shows the screen behavior during an automatic or manual reset condition. The table below the display illustration lists manual reset conditions and how to reset from them.
3. [Figure 85, page 99](#) lists conditions that will cause the control to display a constant red screen. The boiler will automatically restart if the condition self-corrects or the technician uses the Control's manual reset screens to reset.

Figure 84 Control display toggles when in lockout, with screen flashing red to gray

NOTICE: Screen background color alternates from RED to no backlight (gray screen).

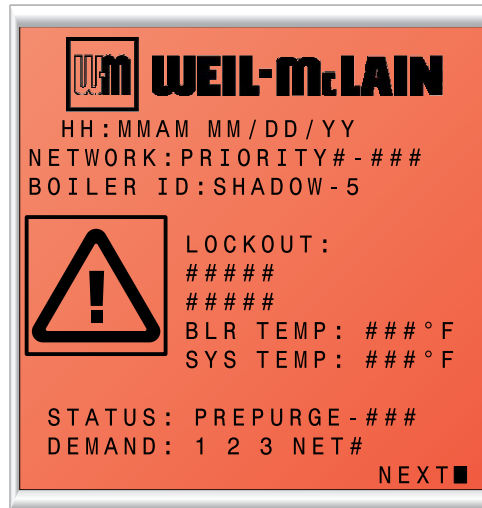

SEE TOP LINE OF DISPLAY FOR ERROR

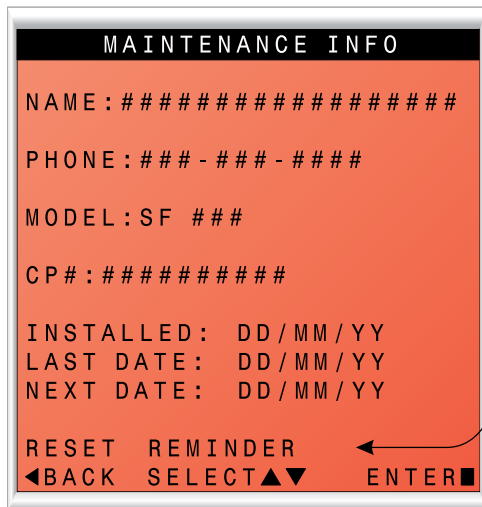

Select **MANUAL RESET** to reset condition. Make sure to correct the cause of the problem if possible.

Select **RESET REMINDER** to reset the counter. The reset reminder will not occur again until the INTERVAL time has elapsed. (Screen flashes blue for maintenance reminders).

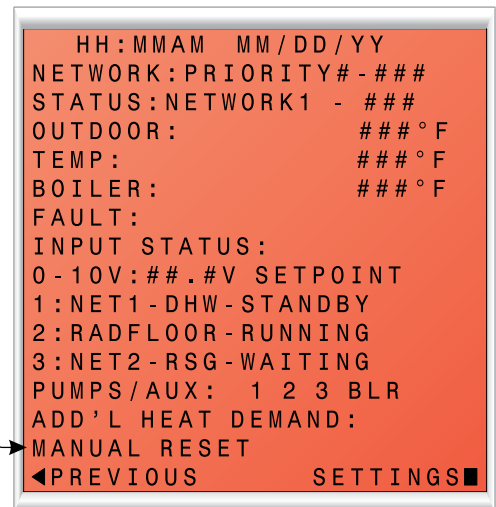

SF-032



Troubleshooting *(continued)*

Figure 85 Troubleshooting suggestions for SlimFit boilers

RESET TO FACTORY DEFAULT

1. Selecting this will prompt the user to hold the enter button for a specified length of time. Upon completion, this will reset the control settings back to factory installed settings. **ONCE THIS IS CHOSEN, PREVIOUS SETTINGS CANNOT BE RECOVERED. ENSURE THIS ACTION IS TRULY DESIRED BEFORE CONTINUING.**
2. Reset to Factory Default can be found on the BOILER SETTINGS menu, see [Figure 62, page 73](#).

Control Error Condition Log

The Control is able to record information about the boiler’s condition at the time of the three previous faults or errors. This information is available to view in Contractor Menus under “DIAGNOSTICS” by selecting “PAST ERRORS.” The control will display the following information:

Information	Description	Action
Control Fault	Records number	Select and press the enter key to reset this count
Ignition Retries	Displays the number of ignition attempts in the current ignition sequence.	
Manual Reset Count	Records number of lockouts that required a manual reset since this count was last cleared.	Select and press the enter key to reset this count
Auto Reset Count	Records number of lockouts that have automatically reset since this count was last cleared.	Select and press the enter key to reset this count
Lockout History 1	Details of present or last recorded lockout	Select and press the enter key for more details
Lockout History 2	Details of boiler during the second oldest lockout still in memory	Select and press the enter key for more details
Lockout History 3	Details of boiler during the oldest lockout still in memory	Select and press the enter key for more details

How to read the last 3 lockout histories:

1. Scroll down to “DIAGNOSTICS” and press the enter key (Square Key in center)
2. Scroll down to “ERRORS” and press the enter key (Square Key in center)
3. Scroll down to “LOCKOUT HISTORY #” and press the enter key.
4. Scroll to choose the either “MANUAL RESET” or “AUTO RESET” and press the enter key to display the fault condition that was recorded.
5. Press the left arrow key to return to the LOCKOUT HISTORY # screen. Scroll up or down to highlight other choices and press the enter key to view the details of the boiler’s condition when the lockout was recorded.
6. TO CLEAR ALL LOCKOUT HISTORIES: While on the “ERRORS” screen, hold the Left and Right arrow buttons simultaneously for 5 seconds.

How to clear all lockout histories:

1. While on the “PAST ERRORS” screen, hold the Left and Right arrow buttons simultaneously for 7 seconds.

Troubleshooting *(continued)*

Figure 85 Troubleshooting suggestions for SlimFit boilers *(continued)*

Control Fault Displays, Diagnostics and Suggested Corrective Actions			
Display	Condition	Diagnostics	Corrective Action(s)
Nothing shown on display screen and boiler will not respond to call for heat	Control is not receiving 24V power.	Check wiring for short circuit or incorrect wiring.	Correct wiring per wiring diagram including connection of transformer to the control.
		Check 3-amp low voltage fuse on control shown on page 97 .	Replace fuse with proper part found in Replacement parts, starting on page 108 . If fuse blows again recheck wiring per diagram.
		Check transformer connection to the control per wiring diagram. Check for 24V output of transformer.	Replace transformer if it is receiving 120VAC, but not outputting 24VAC.
Nothing shown on display screen and boiler will not respond to call for heat	Control is not receiving 24V power.	Check wiring for short circuit or incorrect wiring.	Correct wiring per wiring diagram including connection of transformer to the control.
		Check 3-amp low voltage fuse on control shown on page 97 .	Replace fuse with proper part found in Replacement parts, starting on page 108 . If fuse blows again recheck wiring per diagram.
		Check transformer connection to the control per wiring diagram. Check for 24V output of transformer.	Replace transformer if it is receiving 120VAC, but not outputting 24VAC.
Nothing is shown in display screen and no other boiler components are operating	Control is not receiving 120V power.	Check service switch and/or circuit breaker to boiler is turned on.	Turn on service switch to power boiler.
		Is there 120 VAC at the service switch?	Troubleshoot and correct the power supply to the service switch.
		Check for 120 VAC at the line voltage terminal block located inside the top left electrical compartment.	Correct wiring inside the control pod using the wiring diagram in this manual.
		Inspect 12-amp fuse as shown on page 97 . Replace if necessary.	Replace the fuse with proper part found in Replacement parts, starting on page 108 . If fuse blows again recheck wiring per diagram.
Nothing is shown on display screen, but boiler is operating	Occurs if the communication is lost from the control to the display.	Check for loose connections and proper pin alignment/engagement on the control's plug P9, Pump/Com board P6 + J1, and the back of the display circuit board.	Check for continuity on the wire harness from the display to the control. See Replacement parts, starting on page 108 .
		Cycle power off and on using boiler power switch and check for operation.	Replace with new display module. See Replacement parts, starting on page 108 .
	or Display contrast needs to be adjusted.	Look at the screen from other angles.	Power cycle the boiler, wait about 45 seconds then Press and hold the Enter button. While holding the Enter button, tap the up or down buttons to adjust the contrast level. If this does not work replace display.
TEMP RISE TOO QUICKLY	Occurs if supply water temperature in heat exchanger rises faster than 2° F per second during the first two minutes the burner is on.	Automatically resets after 1 minute delay or using manual reset on display.	Verify water pipe is installed correctly per instructions in this manual.
		Manual reset is necessary after 5 automatic resets have occurred during the same Priority heat demand. Reset using manual reset screen on display.	Verify proper circulator and speed for boiler size and system requirements.
			See message displayed TEMPERATURE SENSOR and follow procedure for loose connections.
DISPLAY COMM Fault	Occurs if display communications out for 30 seconds.	Automatically resets when communication is re-established.	Check for a loose connection at the molex plug on the control and connection on the back of the display.



Troubleshooting *(continued)*

Figure 85 Troubleshooting suggestions for SlimFit boilers *(continued)*

Control Fault Displays, Diagnostics and Suggested Corrective Actions			
Display	Condition	Diagnostics	Corrective Action(s)
LOW WTR CUTOFF OPEN	Occurs if internal low water cutoff contacts open.	Automatic reset occurs if contacts are open at least one second, but less than 5 seconds. Manual reset of control if contacts are open longer than 5 seconds.	Check for low water condition in system. Repair system as necessary refer to piping section of this manual. If low water condition does not exist, check Diagnostics — Inputs screen to view status of Low Water Cutoff. If shown as OPEN check wiring between LWCO and control. If wiring is alright, remove LWCO and Clean probe. If problem still exist, then replace the LWCO. Low water cutoff indicator light codes: GREEN on = Normal operation GREEN + AMBER on = Service probe soon RED + AMBER = Control locked out RED blinking = LWCO component failure ⚠ WARNING When the service indicator light code occurs, schedule a service appointment as soon as possible to avoid the boiler shutting down on low water lockout. To service the probe, shut off all power supplies to the boiler. Close the boiler isolation valves. Then drain enough water from the boiler to allow removing the low water cutoff. Inspect the probe. Clean if necessary to remove scale accumulation. Reinstall the low water cutoff and restore boiler to operation. If the problem persists, replace the low water cutoff probe.
SUPPLY 58° F > RETURN	Boiler Out temperature has exceeded the Boiler In temperature by more than 58° F.	Automatically resets after 30 second delay when conditions no longer exist or using manual reset on display.	Verify water pipe is installed correctly per instructions in this manual.
			Verify proper circulator and speed for boiler size and system requirements.
			See message displayed TEMPERATURE SENSOR and follow procedure for loose connections.
RETURN > SUPPLY	Occurs if a return water temperature is greater than the corresponding supply temperature by 10° F or more.	Automatically resets when condition no longer exists.	Verify proper flow direction of the boiler circulator. Verify proper placement of system sensors for single or multiple boiler system. System sensors should be on system piping not on the boiler loop. Verify sensors are wired to correct terminal locations. System sensors may need to be located further away from the boiler loop connection to the system, if proximity to the boiler loop is causing sensors to be heated inaccurately.
SUPPLY WATER TEMPERATURE TOO HIGH	Occurs when the System Supply temperature goes above 200° F when the burner is running.	Automatically resets when Supply temperature goes below 200° F.	Verify proper flow direction of the boiler circulator. This circulator must be installed to push water through the system.
TEMPERATURE SENSOR FAULT	Occurs if a temperature sensor has electrically shorted (SHORT) or has become disconnected (OPEN).	Will automatically reset if the condition clears.	Check all the temperature readings of the boiler on the DIAGNOSTICS - TEMPERATURES menu to determine if any sensors are currently displayed as SHORT or OPEN. Compare this to the boiler temperatures recorded in the DIAGNOSTICS - ERRORS - LOCKOUT HISTORY # - TEMPERATURES during the last several lockout conditions. Determine which sensors are suspect and measure their resistance value and compare it to the values shown in Figure 81, page 94 . If the resistance values are incorrect replace the temperature sensor. Refer to Replacement parts, starting on page 108 for proper part number.
			Check wire harness for loose connections and pin engagement at sensor connection, chassis mount connection through control housing, and the control. Unplug connection at sensor and at control and check continuity between ends.
			If problem persists after checking items above, replace control. Refer to Replacement parts, starting on page 108 for kit number.
	Occurs if dual temperature sensors values have spread by more than 10° F if the burner is on.	Automatically resets when sensors are within 10° F.	Follow procedure for above for SHORT and OPEN sensor conditions to properly diagnose sensor. If measured resistance values of sensors convert to temperatures separated by more than 10° F replace the sensor.



Troubleshooting *(continued)*

Figure 85 Troubleshooting suggestions for SlimFit boilers *(continued)*

Display	Condition	Diagnostics	Corrective Action(s)
LIMIT OPEN	Occurs if manual or automatic reset limit opens.	Automatic external limit will reset 2½ minutes after external limit device closes. Manual limit fault must be reset by choosing Manual Reset on the display.	Is there an external safety device connected? If yes, trouble shoot the external limit to determine and correct the cause that opened the limit. Also check for loose wiring connections.
			Remove the top right Control tray cover and inspect the connector. Ensure a jumper is installed across the MAN LIMIT terminals if not using a manual reset external limit. Ensure a jumper is installed across the AUTO LIMIT terminals if not using an automatic reset external limit.
HIGH TEMP LIMIT	Boiler temperature sensor reached High Temp Limit setting (no higher than 200° F).	Reset using manual reset screen on display.	Verify that high limit setting is at least 10° F above the maximum target temperature plus the off differential .
			Verify all isolation valves are open and circulators are programmed into the control properly.
			The boiler circulator output and System Pump/Aux. output can be configured to turn on or off with each priority. Refer to the Control Setup section to configure these properly for the system.
			Verify water pipe is installed correctly per instructions in this manual.
			Verify proper circulator sizing for boiler size and system requirements.
See message displayed TEMPERATURE SENSOR and follow procedure for loose connections.			
FLAME FAULT	Occurs if flame is detected when there should be no flame.	Reset using manual reset screen on display.	Burner may be operating too hot due to incorrect combustion. Inspect flame and conduct combustion test. Force boiler into high fire. Check flue gases with combustion analyzer and correct using the maintenance and startup procedure in this manual.
			Verify FLAME SIGNAL value quickly goes to zero on the DIAGNOSTICS - INPUTS screen when the gas valve closes.
			Check for flame at burner via flame current with burner off. Turn boiler off and watch flame through observation port. If flame continues after shut down replace gas valve.
BLOWER FAULT	Blower unable to reach required speed or does not reach 0 RPM when turned off.	Reset using manual reset screen on display; Control will check again after 1 hour and will automatically restart if condition is corrected.	Check wire harness for loose connections and pin engagement at blower connections, chassis mount connection through control housing, and control. Unplug connection at blower and at control and check continuity between ends. Blower is connected to both low voltage and line voltage harness.
			Check Diagnostics - Inputs screen with boiler in standby mode and blower not running. If BLOWER SPEED is not 0 RPM then replace blower.
			If blower does not rotate during ignition sequence check for 120V power at blower connection. If 120 VAC power at blower motor and it doesn't start replace blower. Check power at control. If 120VAC is not present at control when boiler is powered replace Control. Refer to Replacement parts, starting on page 108 .



Troubleshooting *(continued)*

Figure 85 Troubleshooting suggestions for SlimFit boilers *(continued)*

Display	Condition	Diagnostics	Corrective Action(s)
IGNITION FAULT	Boiler went through 5 ignition attempts and never detected flame or flame sense value never reached minimum threshold for boiler model.	Automatically resets after 1 hour or can be reset by performing manual reset on boiler.	Check condensate trap for blockage allowing condensate to accumulate inside heat exchanger. Check ignition cable connection.
			Fouled, worn, bent, or faulty igniter. Fouled igniters can be cleaned for additional use with steel wool. Worn or badly fouled igniters should be replaced with the proper repair part. Igniter rods should be parallel with a 3.5 mm (0.138 in) spark gap. NOTICE: Thin white deposits on the igniter are typical, but brown or black deposits could be the result of flue gas recirculation. Thoroughly inspect the venting system and termination for the possibility of leakage or flue gas feedback into the air line.
			Dirty burner and/or heat exchanger will cause high back pressure and poor ignition. Follow procedure in maintenance section of this manual to clean burner and heat exchanger. Visual inspection of flueways may not be sufficient to diagnose condition.
			Check combustion settings on high and low fire and adjust per setup instructions if necessary.
			Check incoming gas pressure with boiler off and at high fire. Adjust within limits on rating label.
			Verify correct boiler model and altitude is selected in control and correct elevation must be entered when operating above 2,00 feet.
			Check ignition cable resistance. Should measure 1000 Ohms (+/- 50 Ohms).
			Check for flue pipe and intake pipe restrictions or blockage.
			Check burner fasteners and gaskets.
			Check venturi gaskets and proper venturi. (Propane models use different venturi's).
AIR PRESSURE Switch Open	Occurs when Air Pressure connection is open.	Reset using Manual Reset screen on display. High pressure in the exhaust pipe or high vacuum in the boiler intake or cabinet has caused the air switch to open. The switch is closed in normal operating conditions.	Check boiler size selected in control against boiler rating label. Correct if necessary to select the proper boiler size.
			Check exhaust and intake pipe for restrictions or blockage.
			Check condensate drain for blockage. If condensate is unable to drain out of the boiler it can begin to block the flow of exhaust gases. Clean the condensate collection area of the base and condensate trap. Refill trap with fresh water.
			Check the P7 connection as seen on Figure 52, page 60 & Figure 53, page 62 . Check the connections on the pressure switch.



Troubleshooting *(continued)*

Figure 85 Troubleshooting suggestions for SlimFit boilers *(continued)*

Display	Condition	Diagnostics	Corrective Action(s)
GAS PRESSURE SW FAULT	Gas pressure switch is open (high or low).	Either the low gas pressure switch or high gas pressure switch has opened due to incorrect gas pressure being supplied to the boiler. Remove front door of boiler and look at pressure switches. The upper switch is the low gas pressure switch and the lower one is a high gas pressure switch. Whichever switch has locked-out will have an indicator light on. Switches can be reset by pushing on plastic cover in the middle of the dial as indicated on the switch. Control will also need reset using display after gas pressure switch has been reset.	<p>Check gas pressure at tee mounted behind gas pressure switches during high and low fire and boiler off. Pressure should always be with limits on rating label. Undersized gas supply pipes or regulators may cause low gas pressure issues while the boiler is operating and possibly high gas pressure when the boiler shuts down.</p> <p>Insure the pressure regulator in the gas supply line is a lockup-type.</p> <p>Ensure gas pressure switch settings are correct. Low Pressure Switch Setting = 2 inches H2O High Pressure Switch Setting = 14 inches H2O</p>
HW FAULT EXPANSION BRD	Expansion Control Board hardware has failed.	Expansion Control Board has detected an issue with it's hardware and has locked out. Requires a manual reset.	Check boiler size selected in Control against boiler rating label. Correct if necessary to select the proper boiler size.
GV FAULT EXPANSION BRD	Gas valve output of the Expansion module.	Expansion Control Board has detected an issue with the gas valve circuit. Requires a manual reset.	Check the wire harnesses between the Control, Expansion module, and gas valve.
EXP BOARD COM FAULT	Expansion Control Board communication fault.	Communication has been lost between the Control and the Expansion Control Board.	Check the communication wire harness between the two controls.
PS Fault Exp. Board	Pressure switch issue detected on expansion board.	Unit receives manual reset.	Check connections to expansion board. Check air and gas pressure switches
Hardware Fault	Occurs when micro-controllers on main board have a RAM or ROM error, or communication is cut off.	Check for hardware damages.	RAM or ROM errors can be reset with the manual reset option. If problems persist, replace main board.
Hardware Fault X	The control has detected a problem with its gas valve output circuit.	Auto reset if condition is clear after lockout, then 1 hour automatic reset if condition clear, then manual reset required.	Check for physical damages. Check connections to gas valve and gas pressure. If problem persists, replace main board.
Closure Switch Fault	Proof of Closure connections on P7 Pins 2 and 3 are open	Soft lockout for 3 ½ minutes boiler retries. Each consecutive failure adds 1 minute to lockout time, up to 6 ½ minutes maximum.	None – Check jumper on correct pins and secure connection. Flow switch attached – Check correct pump is on, check wiring to flow switch, and check switch is closing. CAD – Check voltage to damper. Check damper is opening.
OUTDOOR SENSOR ERROR	Outdoor temperature sensor short or OPEN.	Will automatically reset if the condition clears. Warning only. Supply Max is targeted until ODT is restored, if used for target adjustment.	<p>Determine which sensors are suspect and measure their resistance value and compare it to the values shown in Figure 83, page 97. If the resistance values are incorrect replace the temperature sensor. Refer to Replacement parts, starting on page 108 for proper part number.</p> <p>Check wire harness for loose connections and pin engagement at sensor connection, chassis mount connection through control housing, and the control. Unplug connection at sensor and at control and check continuity between ends.</p> <p>If problem persists after checking items above, replace control. Refer to Replacement parts, starting on page 108 for kit number.</p>
Flue Temp Too High	Occurs if flue temperature sensor exceeds 210°F (Warning) or 220°F (Lockout).	Automatic reset occurs if temperature drops below 210°F for 2 ½ minutes. Manual reset is required if the temperature rises above 220°F. Reset using manual reset screen on display.	<p>Follow procedure above for SHORT and OPEN sensor conditions to properly diagnose sensor. In addition inspect heat exchanger combustion chamber and flue-ways for abnormal wear and buildup.</p> <p>Inspect vent system for abnormal wear or damage.</p> <p>Contact WM Technologies Technical Support.</p>



Maintenance

Disconnect power

⚠ WARNING Electrical shock hazard — Disconnect all electrical power to the boiler before attempting maintenance procedures. Failure to complete could result in severe personal injury, death or substantial property damage.

Install boiler jacket front door after startup or servicing

⚠ WARNING Reinstall boiler jacket front door after start-up or servicing. The boiler front door must be securely fastened to the boiler to prevent boiler from drawing air from inside the boiler room. This is particularly important if the boiler is located in the same room as other appliances.

Inspect boiler jacket door gaskets. Gaskets must be in good condition, with no tears or gaps. Replace if necessary.

Failure to keep the door securely sealed and fastened could result in severe personal injury or death.

Perform start-up and check/out

⚠ WARNING Removing and reinstalling components can change boiler behavior. After any maintenance procedure, you must prove the boiler is operating correctly. To do so, follow the complete procedure for boiler and system start-up, beginning on [page 85](#). Failure to comply could result in severe personal injury, death or substantial property damage.

General maintenance

1. Oil motors in system requiring regular oiling.
2. See Oiled bearing circulators for motor oiling procedures.

Oiled bearing circulators

Check circulators in the system. Oil any circulators requiring oil, following circulator manufacturer's instructions. Over-oiling will damage the circulator.

Cleaning the heat exchanger — pin side when required

1. Shut down boiler:
 - a. Follow “To Turn Off Gas to Appliance” instructions on boiler and Lighting instructions.
 - b. Do not drain boiler unless it will be exposed to freezing temperatures. If using freeze prevention fluid in system, do not drain.
2. Allow time for boiler to cool to room temperature if it has been firing.
3. Rotate the two rotary latches on the front door. Tilt the top of the door forward, then lift up. Use a 13-mm wrench or socket to remove the nuts on the front cover plate and remove the plate. Use the cleanout plug in the flue pipe to rinse debris into the condensate drain. Flush the condensate drain, then refill.
4. Follow the applicable procedures under [Accessing & cleaning the heat exchanger, page 106](#).

Clean the cast aluminum heat exchanger when required — water side

1. In order for the efficiency of boilers to increase beyond the condensing limit, new materials have been introduced for the heat exchanger, including aluminum.
2. Aluminum has excellent heat transfer characteristics and is light in weight.
3. These new materials also require cleaning solutions that differ from those used in conventional cast iron and steel boilers.

⚠ WARNING One common cleaning method that **CANNOT** be used with systems containing aluminum is a solution of trisodium phosphate, commonly referred to as “TSP”

The reason that trisodium phosphate cannot be used is that the cleaning solution has a very high pH level — while removing the scale in the system, it also removes the natural protective oxide layer from the aluminum. The oxide layer will reform, but if small amounts of the trisodium phosphate remain in the system, the chemical will continue to remove the protective oxide layer, leading to reduced heat exchanger life.

4. Use **ONLY** the cleaning product available from WM Technologies, Sentinel X400. See the [Replacement parts, starting on page 108](#) for ordering information.



Maintenance *(continued)*

Accessing & cleaning the heat exchanger

Remove heat exchanger cover plate and burner

1. Close the external manual gas valve.
2. Disconnect all power to the boiler.
3. Allow the boiler to cool if it has been operating.
4. Use a 13-mm wrench or socket to remove the nuts that secure the heat exchanger cover plate to the heat exchanger ([Figure 86, page 107](#)).
5. Follow the procedure on [page 94](#) to remove the burner. Disconnect wire harnesses as required to move the mixing tube and blower assembly out of the way.

CAUTION Label all wires prior to disconnection when servicing controls. Wiring errors can cause improper and dangerous operation. Always disconnect power to boiler before servicing. Failure to comply could result in severe personal injury, death or substantial property damage.

6. Remove the flue inspection cover.

Use heat exchanger cleaning tool

1. Use the Heat Exchanger Cleaning Tool (supplied with the boiler) or a piece of 20-gauge or lighter sheet metal $\frac{3}{4}$ " wide by about 18 inches long to loosen deposits.
2. Slide the cleaning tool through the heat exchanger pins in the three directions shown in [Figure 87, page 107](#).
3. Vacuum most of the debris out of the base through the flue inspection opening.

Water spray the heat exchanger

1. Disconnect the condensate line at the bottom of the heat exchanger so debris will not clog the trap.
 - a. Loosen the hose clamps at both ends of the condensate line.
 - b. Remove the line and place a pan under the trap connection.
2. Use the burner opening to spray water down onto the heat exchanger pins. Continue spraying until all debris on the pins has been flushed into the base.
 - a. Spray water into the flue inspection opening to flush remaining sediment to the condensate outlet.
 - b. Spray water through the condensate line to clean it thoroughly.
 - c. Remove the pan and re-install the condensate line.
 - d. Re-install the flue inspection plug.

WARNING

If the silicone cord gasket has been damaged or stretched, replace it before placing the boiler back in operation. To install the silicone cord gasket:

- When installing the silicone cord gasket, the seam should start at the top middle of the gasket groove. See [Figure 86, page 107](#).
- Carefully place the cord in the groove all around the cleanout plate.
- Do not splice pieces together. The gasket must be installed as one piece.
- When inserting the gasket, do not stretch the cord or stretch around corners. This could cause the cord not to seal correctly, resulting in possible flue gas or condensate leakage.

Failure to comply could result in severe personal injury, death or substantial property damage.

Inspect cover plate gasket

1. Inspect the silicone cord heat exchanger cover plate gasket. Replace if damaged.
2. Make sure the cover plate gasket is in the groove of the heat exchanger.
3. Inspect the cover plate insulation, replace if damaged.

Re-install cover plate

1. Re-install the cover plate following the sequence shown in the appropriate illustration, [Figure 88, page 107](#) or [Figure 89, page 107](#).
2. Re-install the hex head nuts on the cover plate mounting studs and tighten in the staggered pattern shown for the boiler model ([Figure 88, page 107](#) for SF-550 or [Figure 89, page 107](#) for SF-750) until the cover plate is uniformly tightened.

WARNING

Gradually tighten the cover plate nuts in the sequence shown. Torque to 18 N-m/160 in-lbs/13 ft-lbs.

Re-install burner, mixing tube and blower assembly

1. Follow the procedure on [page 94](#) to re-install the burner and other components.
2. Reconnect wiring, including the ignitor ground wire connection to the top ignitor mounting screw.

Restart and test the boiler

1. Restore gas supply and power to the boiler.
2. Start the boiler and verify operation following the procedures given in this manual.



Maintenance *(continued)*

Figure 86 Removing heat exchanger cover plate

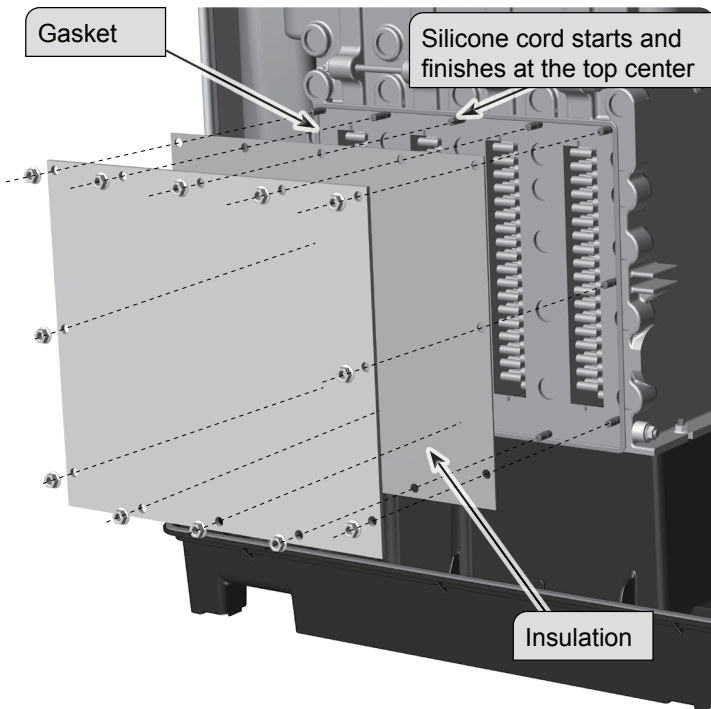

Figure 87 Cleaning heat exchanger with cleaning tool

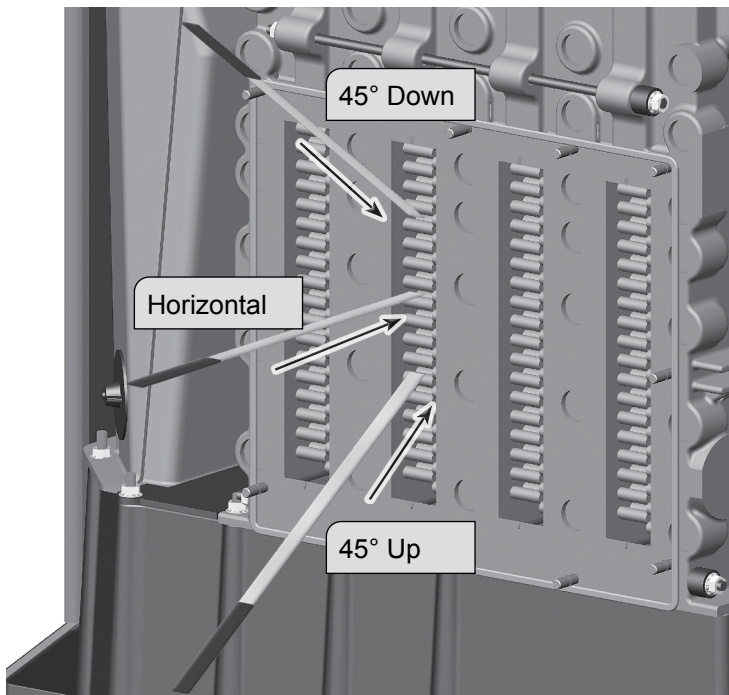

Figure 88 Nut tightening sequence — SF-550
Gradually tighten the nuts, repeating the sequence shown below until the torque reaches 160 inch-pounds +/- 10 inch-pounds / 18 N-m +/- 1 N-m

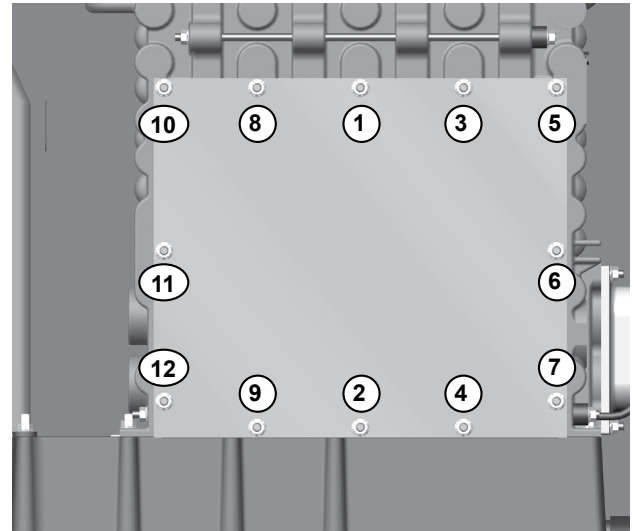
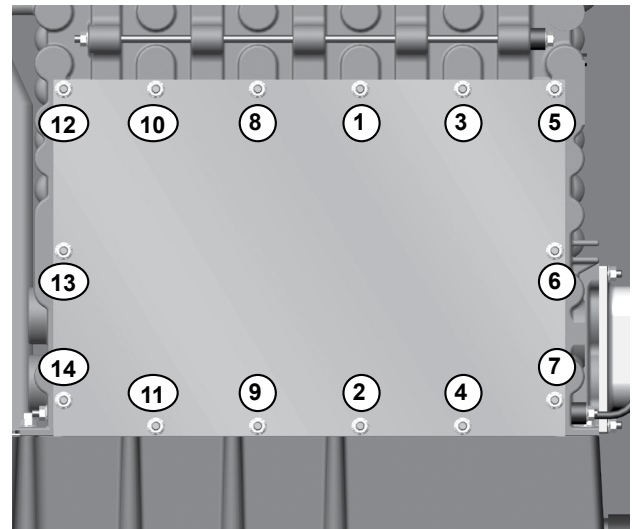

Figure 89 Nut tightening sequence — SF-750
Gradually tighten the nuts, repeating the sequence shown below until the torque reaches 160 inch-pounds +/- 10 inch-pounds / 18 N-m +/- 1 N-m





Replacement parts

▲WARNING Replacement parts must be purchased through a local WM Technologies distributor. When ordering, specify boiler model and size and include description and part number of replacement part. Results from using modified or other manufactured parts will not be covered by warranty and may damage boiler or impair operation.

NOTICE Weil-McLain part numbers are found in Weil-McLain Boilers and Controls Repair Parts Lists.

▲WARNING **The boiler contains ceramic fiber materials.** Use care when handling these materials per instructions on [page 91](#) of this manual. Failure to comply could result in severe personal injury.

Reinstall boiler jacket front door after startup or servicing

▲WARNING Inspect boiler jacket front door gaskets and reinstall boiler jacket front door after start or servicing. The boiler front door must be securely fastened to the boiler to prevent boiler from drawing air from inside the boiler room. This is particularly important if the boiler is located in the same room as other appliances. Failure to keep the door securely fastened could result in severe personal injury or death.

Figure 90 Propane conversion kits

▲WARNING Propane conversion must follow the instructions in this manual. Refer to [page 8](#) for details.

Natural to propane conversion kits — provided with boiler			
Sea level (up to 5,500 feet) and High altitude (over 5,500 feet)			
Model	Kit part #	Kit includes	Instructions
SF-550	383-600-074	550 LP Propane orifice Propane conversion label	See page 8 .
SF-750	383-600-075	750 LP Propane orifice 750 LP Blower orifice plate (2) blower orifice plate gaskets Propane conversion label	



Replacement parts *(continued)*

Figure 91 Miscellaneous parts and kits

Item	Description	Part Number
1	Condensate neutralizer kit (up to 1000 MBH)	383-600-076
2	Heat exchanger cleaning tool	591-706-200
3	Pressure relief valve ASME 30 PSI, 3/4" NPT female ASME 50 PSI, 3/4" NPT female ASME 80 PSI, 3/4" NPT female	383-600-063 383-600-064 383-600-065
4	Bird screen (1 each required for vent and air pipe termination) 6-inch (for 6-inch vent or air pipe) 8-inch (for 8-inch vent or air pipe)	560-907-633 560-907-634
5	CHEMICALS Antifreeze, aluminum-safe, Sentinel X500 (1 gallon) Antifreeze, aluminum-safe, Sentinel X500 (5 gallon) Corrosion inhibitor, Sentinel X100 (one tube, 275 ml) Inhibitor quick-test kit. Cleaner, Sentinel X400 (one tube, 275 ml)	592-900-029 592-900-006 592-900-002 592-900-005 592-900-003
6	Annual maintenance kit (for SF-550 or SF-750) consisting of: (1) ignitor (2) washers for ignitor (2) blower connection gaskets (1) ignitor gasket (1) inhibitor test kit (1) length of silicone cord for cleanout (2) screws for ignitor (1) suppressor plate	383-600-079
7	Vent adapter 6" for stainless steel vent pipe AL29-4C, Dura-Vent – FasNSeal™	383-600-083
8	Minimum Water Flow Switch Kit	384-000-324
9	Isolation Valve, 2 Inch NPT	384-000-368
10	Replacement Isolation Valve Actuator	1004909026
11	Isolation Valve Position Switch	1004907211
12	Circulator Taco VR15M 1/1-2 Inch	511-405-157
13	Wireless Outdoor Temperature Sensor Kit	384-000-325



Replacement parts *(continued)*

Figure 92 Jacket parts

Item	Description	Part Number for SlimFit 550/750
1	Jacket front door	383-600-519
2	Door seal	383-600-022
3	Handle (2 required)	383-500-517
4	Back Jacket	383-600-526
5	Jacket seal kit (base seal, door seal, grommets and gaskets)	383-600-053
6	Plastic top cover (includes cover, gaskets and hardware)	383-600-054
7	Inlet/outlet adapter	593-000-052

Go to www.weil-mclain.com to locate WM Technologies distributors



Replacement parts *(continued)*

Figure 93 Jacket parts

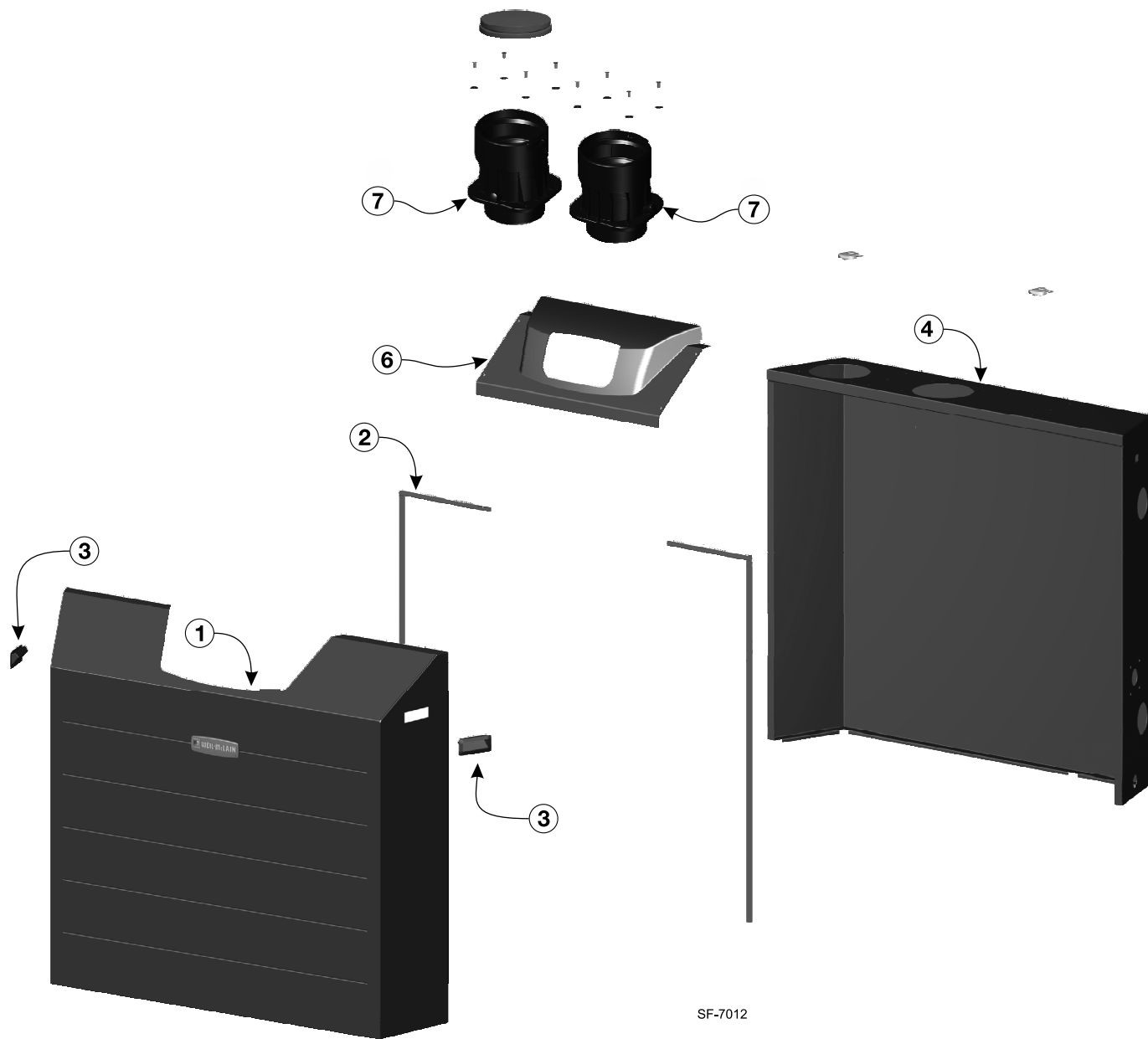

SF-7012



Replacement parts *(continued)*

Figure 94 Heat exchanger

Item	Description	Boiler Models	Part Number
1	5 section heat exchanger assembly kit (includes sections, o-rings, sealing cord & hardware)	550	383-600-029
2	6 section heat exchanger assembly kit (includes sections, o-rings, sealing cord & hardware)	750	383-600-028
3	Left end section replacement kit (includes section, o-rings, sealing cord and hardware)	550 / 750	383-600-036
4	Intermediate section replacement kit (includes section, o-rings, sealing cord and hardware)	550 / 750	383-600-037
5	Right end section replacement kit (includes section, o-rings, sealing cord and hardware)	550 / 750	383-600-038
6	Section/manifold o-ring, 60-mm (single o-ring only)	550 / 750	590-318-039
7	5 section draw rod kit	550	560-134-510
8	6 section draw rod kit	750	560-134-511
9	5 section heat exchanger cover plate kit (includes plate, nuts, sealing cord, insulation and silicone RTV sealant)	550	383-600-040
10	6 section heat exchanger cover plate kit (includes plate, nuts, sealing cord, insulation and silicone RTV sealant)	750	383-600-041
11	5 section supply distribution tube kit (distribution tube, o-ring and nuts)	550	383-600-033
12	6 section supply distribution tube kit (distribution tube, o-ring and nuts)	750	383-600-032
13	5 section return distribution tube kit (distribution tube, o-rings and nuts)	550	383-600-031
14	6 section return distribution tube kit (distribution tube, o-rings and nuts)	750	383-600-030
15	Return manifold casting kit (includes manifold, o-ring and nuts)	550 / 750	383-600-034
17	Plastic flue pipe	550 / 750	560-907-673
18	Plastic base assembly kit (includes base, sealing cord, silicone RTV sealant and hardware)	550 / 750	383-600-026
19	Adapter Flue Pipe / Inlet-Air Bottom	550 750	593-000-053 593-000-054
20	Base seal kit (base sealing gasket cord)	550 / 750	383-600-021
21	Red silicone cord kit (cover plate and base)	550 / 750	383-600-020
22	Tube of silicone RTV, high temperature, red	550 / 750	513-000-001
23	Tube of silicone RTV, high adhesive, black	550 / 750	513-000-000
24	Return distribution tube o-ring, 45 mm	550 / 750	590-318-040
25	Heat exchanger o-ring replacement kit (Not shown) [includes (18) 60-mm o-rings (Item 6); (2) 45-mm o-rings (Item 24); sealing cord; and silicone RTV sealant]	550 / 750	383-600-039

Go to www.weil-mclain.com to locate WM Technologies distributors

Replacement parts *(continued)*

Figure 95 Heat exchanger

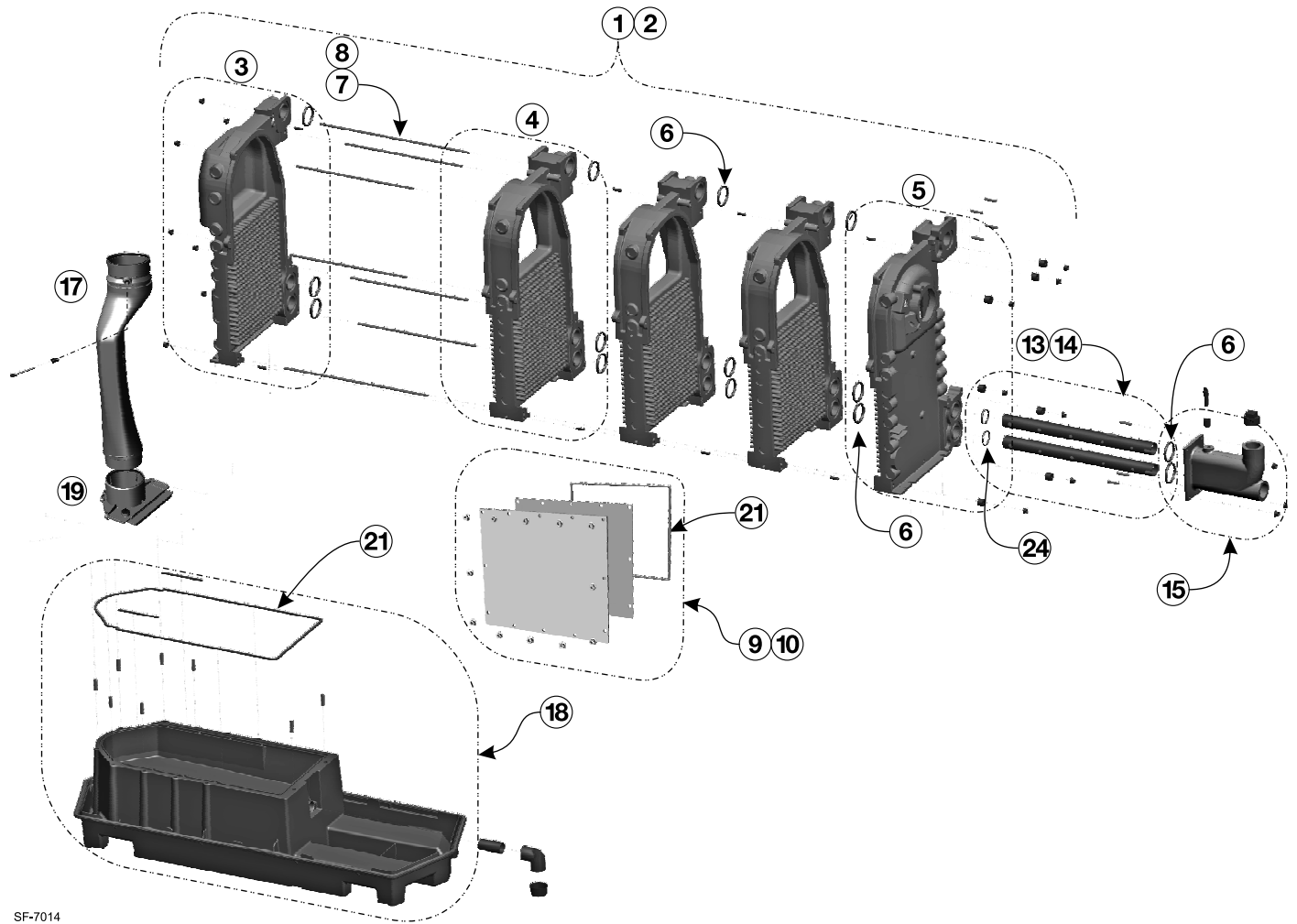

SF-7014



Replacement parts *(continued)*

Figure 96 Piping

Item	Description	Boiler Models	Part Number
1	Supply manifold kit (Includes items 5 through 8 and 10 through 14)	550 / 750	383-600-520
2	Return pipe kit (includes items 9 and 14)	550 / 750	383-600-035
3	Inlet gas pipe kit (includes items 16, 17, and 18)	550 / 750	383-600-056
4	Supply distribution pipe	See Figure 95 , page 113	
5	Serrated-flange nut, M8-1.25 (four (4) required)	550 / 750	In Item 1
6	Supply distribution manifold, 2" NPT	550 / 750	In Item 1
7	Section/manifold o-ring, 60 mm (included in Item 1; also see Item 6, Figure 95 , page 113)	550 / 750	590-318-039
8	Supply/return pipe grommet, 2" NPT x 3½" diameter (included in Item 1)	550 / 750	562-248-747
9	Plug, ½" NPT	550 / 750	In Item 1
10	Low water cut-off	550 / 750	383-600-069
11	Supply temperature sensor	See Figure 101 , page 119	
12	Return pipe, 2" NPT	550 / 750	In Item 2
13	Inlet gas pipe with flange	550 / 750	In Item 3
14	Inlet gas pipe gasket (included in Item 3)	550 / 750	590-300-017
15	Screws, 3/8-16 x ½", button head; washers, 3/8" SAE (4 of each required)	550 / 750	In Item 3



Replacement parts *(continued)*

Figure 97 Piping

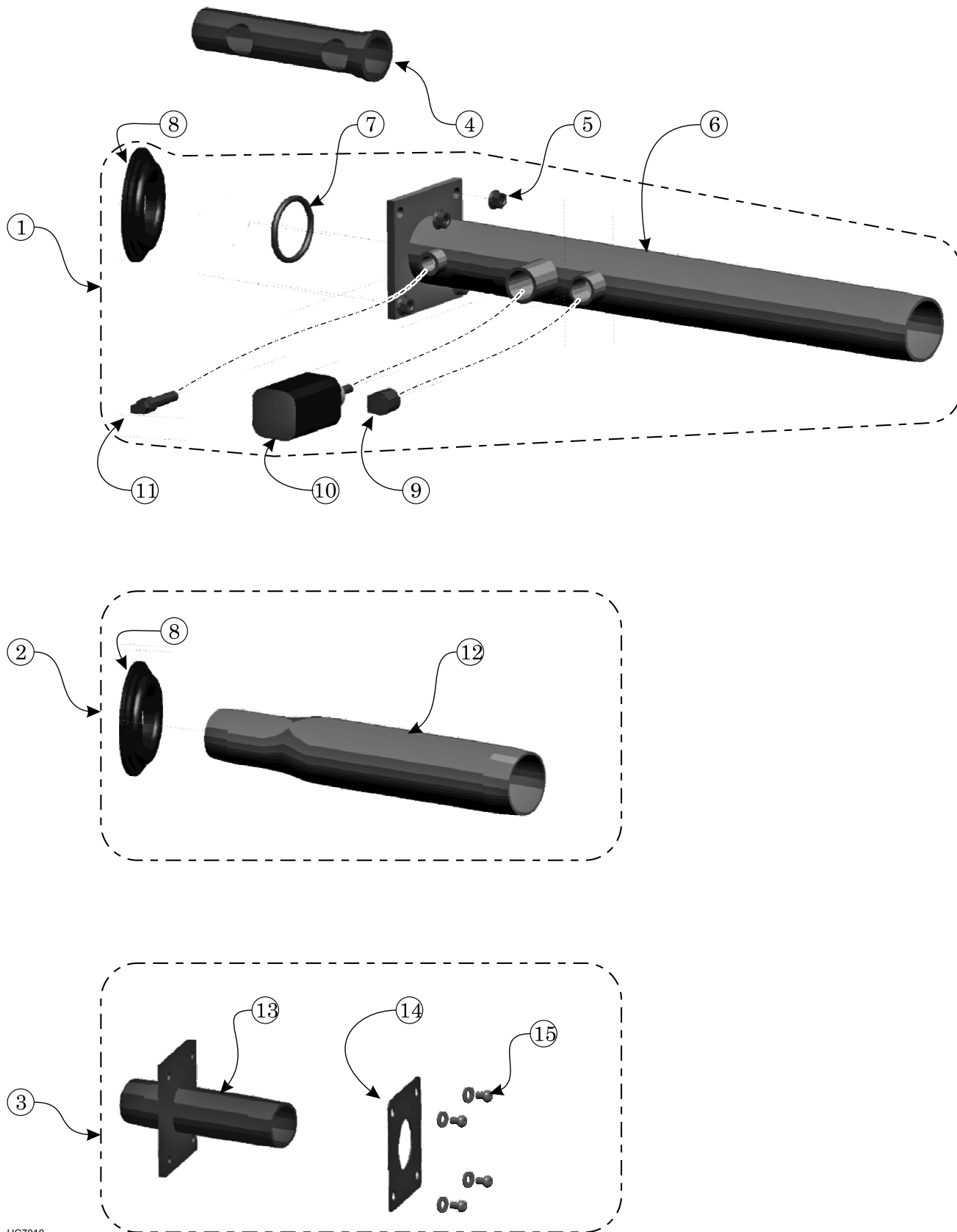

UC7010



Replacement parts *(continued)*

Figure 98 Burner, blower, venturi and gas train

Item	Description	Part Number for SlimFit 550/750
1	5 section burner replacement kit (includes burner, gasket and nuts)	383-600-044
2	6 section burner replacement kit (includes burner, gasket and nuts)	383-600-043
3	Blower assembly kit (includes blower, gasket, o-ring and hardware)	383-600-045
4	5 section venturi replacement kit (includes venturi, o-ring and gasket)	383-600-067
5	6 section venturi replacement kit (includes venturi, o-ring and gasket)	383-600-068
6	Venturi to gas pipe gasket	590-300-022
7	Gas valve replacement kit (includes gas valve only)	383-600-066
8	Gas valve to venturi piping kit (includes piping, gasket, o-ring and hardware)	383-600-046
9	O-Ring, gas valve to adapter pipe	590-318-042
10	Low gas pressure switch replacement kit (includes switch and nipple)	383-600-049
11	High gas pressure switch replacement kit (includes switch and nipple)	383-600-048
12	Gas pressure switch piping	383-600-047
13	Gas pressure switch harness (not shown)	383-600-059
14	Gas valve harness (not shown)	591-391-960
15	Flexible gas line	560-900-021
16	Air silencer	560-900-020
17	Inspection glass kit (includes retainer, glass, gasket and screws)	383-500-020
18	Ignition cable kit (not shown)	383-500-619
19	Ignition electrode kit (includes ignitor, gasket and hardware)	383-600-070
20	Venturi-to-blower o-ring (included in item 4 and item 5)	590-318-041
21	Blower outlet gasket (included in item 3)	590-300-018
22	Burner gasket (included in item 1 and item 2)	590-300-011
23	Blower orifice plate for SF-550 (used for both natural gas and propane)	383-600-078
	Blower orifice plate for SF-750 (used only on SF-750 propane)	See propane conversion kit (Figure 90, page 108)

Replacement parts *(continued)*

Figure 99 Burner, blower, venturi and gas train

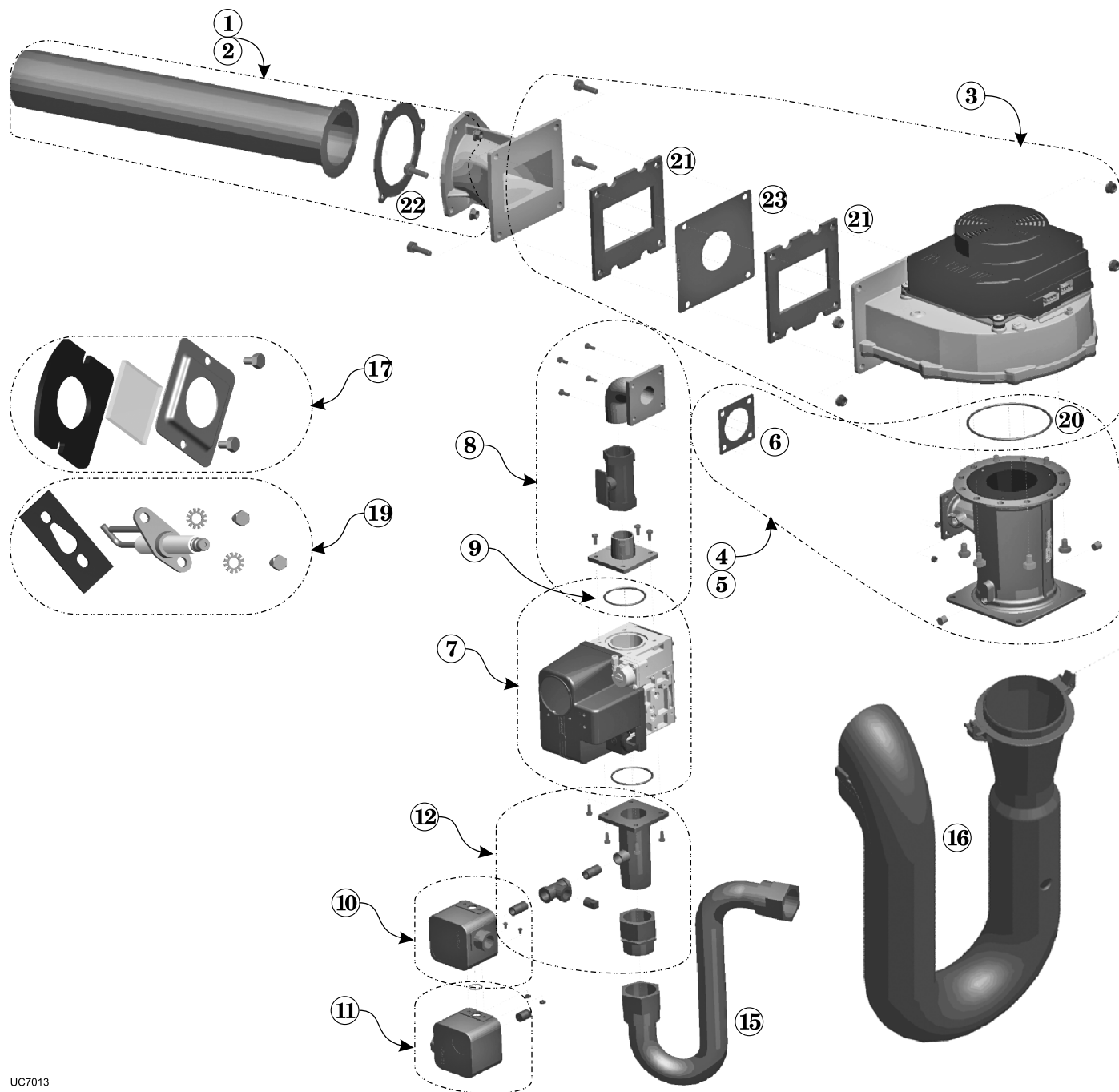

UC7013



Replacement parts *(continued)*

Figure 100 Controls

Item	Description	Part Number for SlimFit 550/750
1	3-amp, fast-blow ATO (5 fuses)	383-500-603
2	12-amp, slow-blow AG (5 fuses)	383 500 604
3	Control module	383-600-162
4	Kit - Service Conversion Series 1 to Series 2 (Includes items 3, 5, 6, 23, 24 & 27)	383-600-164
5	Expansion module	383-600-160
6	Display board assembly	383-600-518
7	Display bracket kit	383-600-042
8	Supply temperature sensor replacement kit, dual sensor (sensor only)	383-600-072
9	Return temperature sensor replacement kit, single sensor (sensor and bushing)	383-600-071
10	Outdoor temperature sensor	510-312-218
11	System temperature sensors	383-500-601
12	Flue Temperature sensor replacement kit (sensor and grommet)	383-500-600
13	Heat exchanger temperature sensor	383-500-602
14	On/off power switch	383-500-205
15	Transformer, 120v/24v	383-500-628
16	Receptacle, 120 volt, 3-wire pre-wired	591-391-959
17	Air pressure switch kit (includes switch, tube and mounting screws)	383-600-073
18	Hose barb for air pressure switch sensing tube connection (not shown)	562-302-525
19	Air pressure switch sensing tube (included in item 18)	In Item 18
20	Blower power relay	570-350-230
21	SlimFit Control terminal block kit (not shown)	383-500-642
22	Control to Expansion Module wire harness, RS485 (not shown)	383-500-633
23	Expansion module to display harness, Cat-se RJ4S (not shown)	383-600-163
24	Upper line voltage wire harness (EP2, EP4, power input and blower relay) (not shown)	383-600-057
25	Low line voltage wire harness (not shown)	591-391-958
26	Upper low voltage wire harness (not shown)	383-600-158
27	Lower low voltage wire harness (P4 through P9 and other) (not shown)	591-391-956
28	Jumper for low voltage terminal blocks (5 jumpers) (not shown)	383-500-641
29	Flue temperature sensor gasket	590-318-011
30	Pressure/ Temperature gauge (not shown)	510-218-099

Go to www.weil-mclain.com to locate WM Technologies distributors



Replacement parts *(continued)*

Figure 101 Controls

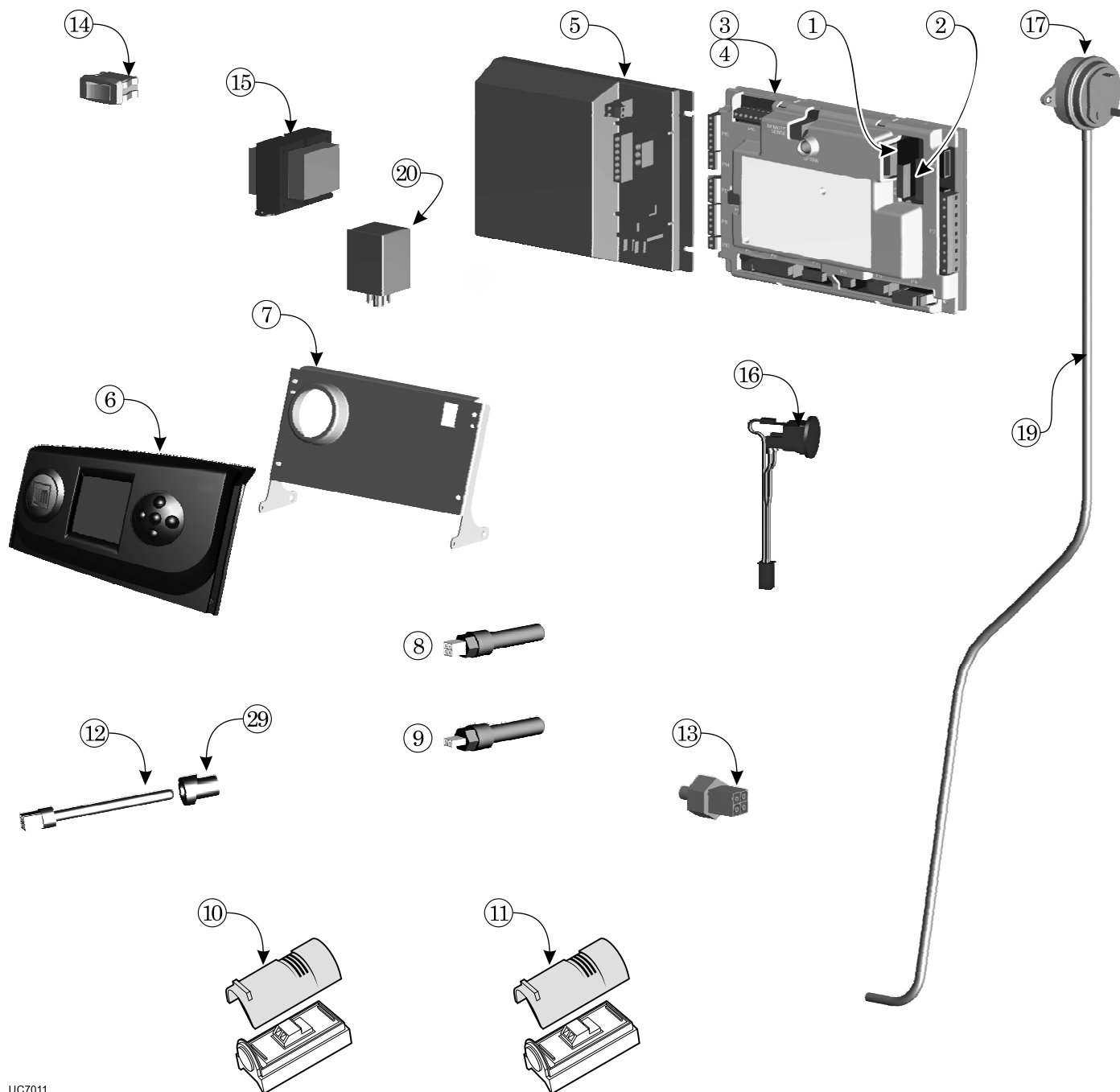

UC7011



Ratings — SlimFit Series 3 boilers

Figure 103 Ratings and engineering data

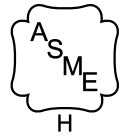

AHRI Certified Ratings							
Boiler Model Number	CSA Input	Gross Output	Net Rating	Combustion Efficiency	Thermal Efficiency	Boiler Water Content	Vent/Air Pipe Size (inches)
	MBH (Note 3)	MBH (Note 3)	MBH (Note 1)	% (Note 2)	% (Note 2)	Gallons	(Note 4)
SF-550	550	517	450	94.7	93.9	5.5	6 or 8
SF-750	750	702	610	94.0	93.6	6.5	6 or 8

Notes	
1	AHRI Net ratings are based on net installed radiation of sufficient quantity for the requirements of the building and nothing need be added for normal piping and pickup. Ratings are based on a piping and pickup allowance of 1.15. An additional allowance should be made for unusual piping and pickup loads.
2	Combustion efficiency and thermal efficiency are based on AHRI testing procedure per BTS-2000.
3	Ratings shown are for sea level applications only. For altitudes above sea level, the SlimFit boiler requires no modifications and automatically derates itself by approximately 4% per 1000 feet above sea level. For elevations over 5,500 feet, configure the Control with HIGH ALTITUDE = YES.
4	SlimFit boilers can be direct vent or direct exhaust vented, either through a side wall or through roof, as instructed in this manual and compliant with all local codes. SlimFit Boilers require special venting, consistent with Category IV boiler. Category II, 8” venting requires 8” vent adapter, see pages 33-34. Use only the vent materials and methods identified in this manual.



Ratings — multiple SlimFit Series 3 boilers

Figure 104 Ratings and engineering data (see Figure 106, page 123 for notes)

Boilers in system		Total CSA input	Total Gross Output	Total Net Rating	Total Boiler H.P.	Manifolded combustion air duct size	Foundation size			
							Side-to-side arrangement <i>(height 2" to 4")</i>		Back-to-back arrangement <i>(height 2" to 4")</i>	
		Input, MBH	Output, MBH	MBH	—	Square inches	Length (inches)	Width (inches)	Length (inches)	Width (inches)
SF-550	SF-750					Figure 26, page 36	Note 1			
2		1100	1034	900	30.9	550	106	21	51	40
	2	1500	1404	1220	41.9	750				
3		1650	1551	1350	46.3	825	165	21	110	40
	3	2250	2106	1830	62.9	1125				
4		2200	2068	1800	61.8	1100	224	21	110	40
	4	3000	2808	2440	83.9	1500				
5		2750	2585	2250	77.2	1375	283	21	169	40
	5	3750	3510	3050	104.9	1875				
6		3300	3102	2700	92.7	1650	342	21	169	40
	6	4500	4212	3660	125.8	2250				
7		3850	3619	3150	108.1	1925	401	21	228	40
	7	5250	4914	4270	146.8	2625				
8		4400	4136	3600	123.6	2200	460	21	228	40
	8	6000	5616	4880	167.8	3000				



Ratings — multiple SlimFit Series 3 boilers *(continued)*

Figure 105 Engineering data (see Figure 106 for notes)

Boiler Model	Shipping weight	Operating weight	Water content	Water flow rate per boiler		Vent/air pipe size — Provide a separate vent for each boiler	Electrical service required
	Pounds per boiler	Pounds per boiler	Gallons per boiler	GPM @ 30°F rise	GPM @ 40°F rise		Amps per boiler
		Note 2				Note 3	Note 4
SF-550	505	476	5.5	34	26	6" or 8"	25 (boiler) 15 (Boiler Circulator)
SF-750	550	529	6.5	47	35	6" or 8"	25 (boiler) 15 (Boiler Circulator)

Figure 106 Notes for Figure 104, page 122 and Figure 105

1	<p>Foundation sizes in Figure 104, page 122 provide 12 inches between boilers and approximately 2 inches from boiler to edge of foundation.</p> <p>Smaller foundations are possible with reduced service clearances. See page 7 for details.</p> <ul style="list-style-type: none"> • For side-to-side installations, see Advanced Control Manual. • For back-to-back installations, see Advanced Control Manual.
2	Operating weight is the total weight of the boiler, including water.
3	<p>All SlimFit installations require a separate vent pipe and termination for each boiler. Vent piping cannot be manifolded. Install and terminate vents as described in vent/air installation instructions in this manual.</p> <p>Combustion air piping can be individually piped or manifolded. See Figure 26, page 36, for manifolded air piping.</p>
4	<p>Boiler total amp load is 18 amps, which includes up to three circulators not exceeding 2.2 amps per circulator. Electrical service required is the minimum recommended breaker or fuse size. DO NOT use larger than a 30-amp breaker or fuse.</p> <p>In addition, circulator #4 requires a separate power supply for circulator amperage not to exceed 10 amps. Electrical service required is the recommended breaker size of 15 amps. DO NOT use a higher-amp-rated breaker or fuse.</p>

Installation and Service Certificate

Boiler Data		
Boiler Model / Series SlimFit _____ / Series _____	Date installed _____	
CP Number _____	FUEL: Natural _____ LP _____	Btu Input _____
<p>CERTIFIED THAT:</p> <p><input type="checkbox"/> Installation instructions have been followed.</p> <p><input type="checkbox"/> Check-out sequence has been performed.</p> <p><input type="checkbox"/> Information on next two pages is certified to be correct.</p> <p><input type="checkbox"/> Information received and left with owner/maintenance person.</p>		
<p>Installer _____</p> <p style="text-align: center;">(Company) (Address) (Phone) (Installer's Signature)</p>		



Installation and Gas Boiler Data Collection Sheet

Boiler Model / Series SlimFit _____ / Series _____		Date Installed: _____	
CP Number: _____	Fuel Type: Natural ___ LP ___	BTU Input: _____	
Flame signal on control display at HIGH fire: _____		Flame signal on control display at LOW fire: _____	
Was venturi changed? YES ___ NO ___	Was gas valve throttle adjusted? YES ___ NO ___	Was gas valve offset adjusted? YES ___ NO ___	
Boiler Settings		Network Settings	
Boiler Model: SlimFit _____	Boiler Address: _____	System Type:	_____
Control Type: _____	Net Max On Time: _____ Min	Target Mod Sensor:	_____
High Altitude: YES ___ NO ___	Net Min On Time: _____ Min	Target Adjust:	_____
	Max Rate On Net: _____%	Supply Max:	_____ °F
	Min Rate On Net: _____%	Supply Min:	_____ °F
Manual Reset High Limit Temp: _____ °F	Rotation & Sequence	OD Reset Max:	_____ °F
WWSD Temp: _____ °F	Sequence Type: _____	OD Reset Min:	_____ °F
Adjust Outdoor: _____ °F	Base Rate High: _____%	Volts For Max:	_____ V
Circulator Exercising	Base Rate Low: _____%	Volts For Min:	_____ V
Circulator 1: ON ___ OFF ___	Boiler Rotation Type: _____	Boost Time:	_____ Mins
Circulator 2: ON ___ OFF ___	Rotate Frequency: _____ Days	System Off Diff:	_____ °F
Circulator 3: ON ___ OFF ___	Force Lead Rotation: YES or NO	System On Diff:	_____ °F
Boiler Circ: ON ___ OFF ___	Modbus Settings	Add BLR Diff:	_____ °F
Freeze Protection	Enable: YES ___ NO ___	Drop BLR Diff:	_____ °F
Circulator 1: ON ___ OFF ___	Address: _____	Mod Delay Time:	_____ Mins
Circulator 2: ON ___ OFF ___	Parity Bit: _____	Stabilization Time:	_____ Mins
Circulator 3: ON ___ OFF ___	Baud Rate: _____ bps	Add Delay Time:	_____ Sec
Boiler Circ: ON ___ OFF ___	Stop Bit: YES ___ NO ___	Drop Delay Time:	_____ Sec
Assign Inputs		Max BLR Temp:	_____ °F
Input 1: Priority ___ Aux ___ OFF ___		Boiler On Diff:	_____ °F
Source: TT1 ___ OR 0-10V ___		Boiler Off Diff:	_____ °F
Input 2: Priority ___ Aux ___ OFF ___		Max On Time:	_____ Mins
Input 3: Priority ___ Aux ___ OFF ___		Run Boiler Pump:	YES ___ NO ___
		Run Aux Pump/Output:	YES ___ NO ___
Max Rate Volts: _____ V		Pre Pump:	_____ Sec
Min Rate Volts: _____ V		Post Pump:	_____ Sec
Temp Dependent: YES ___ NO ___		Max Rate:	_____ %
ODT Setpoint: _____ °F		Min Rate:	_____ %
Activate Contact below setpoint: 1st ___ 2nd ___		Max System BTUs:	_____ MBUTs
		Min Boilers On:	_____
		Additional Heat Demand:	1st ___ 2nd ___ OFF ___
		Response Time:	_____ Mins
		ODT	YES ___ NO ___



Installation and Gas Boiler Data Collection Sheet

CO2 @: High Fire _____ % Low Fire _____ %					
CO@: High Fire _____ ppm Low Fire _____ ppm					
Natural Gas / LP input rate measured: HIGH _____ CFH / LOW _____ CFH					
Priority 2 Settings		Priority 3 Settings		Priority 4 Settings (Multi BLR Sys Only)	
System Type:	_____	System Type:	_____	System Type:	_____
Target Mod Sensor:	_____	Target Mod Sensor:	_____	Target Mod Sensor:	_____
Target Adjust:	_____	Target Adjust:	_____	Target Adjust:	_____
Supply Max:	_____ °F	Supply Max:	_____ °F	Supply Max:	_____ °F
Supply Min:	_____ °F	Supply Min:	_____ °F	Supply Min:	_____ °F
OD Reset Max:	_____ °F	OD Reset Max:	_____ °F	OD Reset Max:	_____ °F
OD Reset Min:	_____ °F	OD Reset Min:	_____ °F	OD Reset Min:	_____ °F
Volts For Max:	_____ V	Volts For Max:	_____ V	Volts For Max:	_____ V
Volts For Min:	_____ V	Volts For Min:	_____ V	Volts For Min:	_____ V
Boost Time:	_____ Mins	Boost Time:	_____ Mins	Boost Time:	_____ Mins
System Off Diff:	_____ °F	System Off Diff:	_____ °F	System Off Diff:	_____ °F
System On Diff:	_____ °F	System On Diff:	_____ °F	System On Diff:	_____ °F
Add BLR Diff:	_____ °F	Add BLR Diff:	_____ °F	Add BLR Diff:	_____ °F
Drop BLR Diff:	_____ °F	Drop BLR Diff:	_____ °F	Drop BLR Diff:	_____ °F
Mod Delay Time:	_____ Mins	Mod Delay Time:	_____ Mins	Mod Delay Time:	_____ Mins
Stabilization Time:	_____ Mins	Stabilization Time:	_____ Mins	Stabilization Time:	_____ Mins
Add Delay Time:	_____ Sec	Add Delay Time:	_____ Sec	Add Delay Time:	_____ Sec
Drop Delay Time:	_____ Sec	Drop Delay Time:	_____ Sec	Drop Delay Time:	_____ Sec
Max BLR Temp:	_____ °F	Max BLR Temp:	_____ °F	Max BLR Temp:	_____ °F
Boiler On Diff:	_____ °F	Boiler On Diff:	_____ °F	Boiler On Diff:	_____ °F
Boiler Off Diff:	_____ °F	Boiler Off Diff:	_____ °F	Boiler Off Diff:	_____ °F
Max On Time:	_____ Mins	Max On Time:	_____ Mins	Min On Time:	_____ Mins
Min On Time:	_____ Mins	Run Boiler Pump:	YES___ NO___	Run Boiler Pump:	YES___ NO___
Run Boiler Pump:	YES___ NO___	Run Aux Pump/Output:	YES___ NO___	Run Aux Pump/Output:	YES___ NO___
Run Aux Pump/Output:	YES___ NO___	Pre Pump:	_____ Sec	Pre Pump:	_____ Sec
Pre Pump:	_____ Sec	Post Pump:	_____ Sec	Post Pump:	_____ Sec
Post Pump:	_____ Sec	Max Rate:	_____ %	Max Rate:	_____ %
Max Rate:	_____ %	Min Rate:	_____ %	Min Rate:	_____ %
Min Rate:	_____ %	Max System BTUs:	_____ MBUTs	Max System BTUs:	_____ MBUTs
Max System BTUs:	_____ MBUTs	Min Boilers On:	_____	Min Boilers On:	_____
Min Boilers On:	_____	Additional Heat Demand:	1st___ 2nd___ OFF___	Additional Heat Demand:	1st___ 2nd___ OFF___
Additional Heat Demand:	1st___ 2nd___ OFF___	Response Time:	_____ Mins	Response Time:	_____ Mins
Response Time:	_____ Mins	ODT	YES___ NO___	ODT	YES___ NO___
ODT	YES___ NO___				

