

Models 725 / 850
Commercial Condensing
Gas-Fired Water Boilers

Boiler Manual



⚠ WARNING

Installation and service of the boiler must be performed by a qualified installer or service technician. Read all instructions, including this manual and all other information shipped with the boiler, before installation or operation. Perform steps in the order given. Failure to comply can result in severe personal injury, death or substantial property damage.

Contents

Tools 4

Abbreviations 4

SECTION 1 – SAFETY **5**

Safety Signals **5**

Please Read Before Proceeding **5**

 Boiler Operation 6

 Boiler Water 6

 Freeze Protection Fluids 6

 Damage from Water Contact 6

 Frozen Water Damage 7

SECTION 2 – INSTALLATION **9**

Prepare Boiler Location. **9**

 Installation Compliance Requirements 9

 Checks Before Boiler Installation 9

 Flooring and Foundation 10

 Garage Installation 10

 Openings 10

 Clearances 11

 Air Openings - General 12

 Preparing for Multiple Boilers 13

Prepare the Boiler **14**

 Removing the Boiler from the Crate 14

 Placing the Boiler 15

 Bolting the Boiler to Mounting Blocks 15

 Propane Conversion Procedure (when required) 16

 High Altitude Installations 17

 Pressure Test Preparation 17

 Pressure Test Precautions 18

 Fill the Boiler 18

 Perform Hydrostatic Pressure Test 18

Install Water Piping **19**

 General Piping Information 19

 Pressure and Temperature Gauge 19

 Relief Valve Installation 20

 Pipe Sizing 21

 Expansion Tank and Make-up Water 22

 Diaphragm or Bladder Expansion Tank 22

 Closed-Type Expansion Tank 22

 ZONE VALVE Zoning - General 23

 ZONE VALVE Zoning - Primary/Secondary 24

 ZONE VALVE Zoning - High-flow-rate or High-head-loss DHW
 Circuits 24

 ZONE VALVE Zoning - Variable Primary Flow 25

 ZONE VALVE Zoning - Circulator Zoning, Primary/Secondary 26

 ZONE VALVE Zoning - Radiant Heating, Primary/Secondary 26

 ZONE VALVE Zoning - Water Chiller Systems, Primary/
 Secondary 27

Commonwealth of Massachusetts Installations. **28**

Venting and Combustion Air - General. **29**

 Code Compliance 29

 Venting Methods 29

 Vent and Air Piping 29

 Boiler Categories 29

 Using a Chimney 30

 Combustion Air Contamination 30

 Vent and Air Adapters 31

 Flue Support Clamp 31

Venting and Combustion Air Options **33**

 Existing Vent System 33

 Existing Vent System Test Procedure 33

 Vent and Air Piping Materials 34

 Category II Requirements 35

 Vent and Air Terminations for Category IV 37

DIRECT EXHAUST - Room Air Openings (Cat. II and IV) . **38**

 Combustion Air Provision 38

 Sizing Combustion Air Openings 38

 Special Considerations 38

DIRECT EXHAUST - Vertical Termination (Cat. II and IV) . **40**

 Vertical Termination Location 40

 Multiple Vent Terminations 40

 Vent Piping Installation 41

 Vent Termination Installation 41

DIRECT EXHAUST - Sidewall Termination (Category IV) . **42**

 Sidewall Termination Location 42

 Determine Termination Location 43

 Multiple Vent Terminations 43

 Vent Piping Installation 43

 Vent Termination Installation 44

DIRECT VENT - Room Air Openings (Category IV) . **45**

 Combustion and Ventilation Air Provision 45

 Sizing Air Openings 45

 Special Considerations 45

 Combustion Air Manifold Option 47

DIRECT VENT - Vertical Termination (Category IV) . **48**

 Vertical Termination Location 48

 Multiple Vent Terminations 48

 Vent Piping Installation 48

 Vent and Air Termination Installation 49

DIRECT VENT - Sidewall Termination (Category IV) . **52**

 Sidewall Termination Location 51

 Determine Termination Location 52

 Multiple Vent Terminations 52

 Vent Piping Installation 52

 Vent Termination Installation 53

Install Condensate Components **55**

 Condensate Trap Installation 55

 Condensate Line Connection 55

Gas Piping **56**

 Gas Supply Piping Connection 56

 Check Natural or LP Gas Supply Pressure 57

 Gas Train Diagram 57

 Pipe Sizing for Natural Gas 58

 Pipe Sizing for Propane Gas 58

 Multiple Boiler Applications - Manifolder Gas Supply Lines 58

 Gas Pressure Switches 58

SECTION 3 – ELECTRICAL **59**

Electrical - General **59**

 Power Requirements 60

 Power Supply Connections 60



Field Wiring	61	Gas Valve Leakage Testing	88
Schematic Diagram	62	Verification Check List	89
Ladder Diagram	64		
A. Power Supply — REQUIRED	66	SECTION 5 – MAINTENANCE	91
B. Start Interlocks (Manual/Auto Limit)	66	Maintenance - General	91
C. Auxiliary Inputs #1 and #2	66	Handling Ceramic Fiber Materials	91
D. Air Damper Interlock (Closure Switch)	67	Perform Startup and Checkout	91
E. Ground, High Voltage.	67	Annual Inspection	92
F. Relay A, B, C, and D (120 VAC Pilot Duty Dry Contacts)	68	First-Year Special Inspection	92
G. Master Alarm Relay (Alarm Contacts)	68	General Information	93
H. Enable/Disable (CH TT Input)	69	Inspect the Boiler Area	93
I. 4-20mA Analog Input (4-20mA Remote Setpoint or Modulation)	69	Inspect the Boiler Interior and the Jacket Door Gaskets	93
J. Spare Analog Input	69	Inspect and Clean the Condensate Trap	93
K. HDR Temp Sensor (System Supply)	69	Inspect All Piping for Leaks.	93
L. DHW Stat or Sensor	70	Service and Maintenance Schedules.	94
M. Outdoor Temperature (ODT) Sensor	70	Annual Startup	95
N. Night Setback.	70	Check Air Openings	95
O. 4-20mA Analog Output	71	Flue Vent System and Air Piping	95
P. Ground, Low Voltage	71	Check the Water System	95
Q. Cascade Shield, A to A, and B to B (Multi-boiler A, B, Ground)	71	Check the Boiler Relief Valve.	95
R. MODBUS Com A, B, and Shield	72	Check the Expansion Tank	96
S. ECOM 1, 2, and 3	72	Inspect the Ignition Electrode and Wiring	96
		Inspect the Flame Sense Rod and Wiring	97
		Inspect and Clean the Burner	98
		Inspect the Combustion Chamber	98
		Cleaning the Heat Exchanger - Water Side	99
		Cleaning the Heat Exchanger - Flue Side	99
		Reinstall All Components.	100
		Inspecting the Pressure Switches	102
		Replacing the Pressure Switches	102
		Check Boiler Wiring	104
		Check Control Settings	104
		Perform Startup and Checks	104
		Low Water Cut-Off Test.	104
		Check the Burner Flame	105
		Check the Flame Signal	105
		Check the Flue Gas Temperature	106
		Check Blower Speeds	106
		High Altitude	106
		Manual Test Mode	108
		Reinstall the Jacket Door After Servicing.	108
		Review with the Owner	108
SECTION 4 – OPERATION	73	SECTION 6 – TROUBLESHOOTING	109
Control Setup and Operation	73	Troubleshooting - General	109
Control Startup	73	Errors and Lockouts	109
Home Screen	73	Control Display	109
Information Screen	74	Loss of Power	109
Setup Wizard	74	Loss of Water Level	109
High Altitude Fan Speed Setup.	75	Low Gas Pressure	109
Control Panel	77	High Gas Pressure	109
Touchscreen Interface	77	High Water Temperature	110
Factory Tests	77	Low Air	110
Sequence of Operations	78	Flame Failure.	110
Startup - Fill the System	79	Flame Error.	110
Clean the System.	79	Flue Issue	110
Water Chemistry	79		
Freeze Protection.	80		
Antifreeze.	80		
Fill and Test the Water System	81		
Recommended Inhibitor	81		
Purge Air from the Water System	81		
Check Concentrations Annually	81		
Startup - Final Checks	82		
Check for Gas Leaks	82		
Check Thermostat Circuits	82		
Inspect and Fill the Condensate System	82		
Inspect the Pressure Switch Hoses	84		
Final Checks Before Starting the Boiler	84		
Startup Procedure	85		
Starting the Boiler	85		
Troubleshooting Startup Issues	85		
Check Flame and Combustion	85		
Gas Valve Adjustment	86		
Maximum and Minimum Final Check.	87		
Check Ignition System Safety Shutoff Device	87		
Check the System for Leaks	88		

Contents, continued

SECTION 7 – PARTS 111
 Miscellaneous Parts 111
 Ordering 111
 The SVF Commercial Condensing Water Boiler. . . . 112
 Replacement Parts 114
 Dimensions 120

SECTION 8 – SERVICE INFORMATION 121
 Ratings 121
 Maintenance Log 123
 Installation and Service Certificate. 124
 Notes 124

Tools

Table 1 Common tools needed

Tools Needed	Purpose
1/16" flat blade screwdriver	Wiring on terminal blocks. Removing the throttle screw cover.
3/16" Allen wrench	Removing gas valve pressure tap plugs.
5/16" socket	Removing the control panel cover.
T40 bit	Removing the offset cover and adjusting the offset screw.
3 mm Allen wrench	Adjusting the throttle screw. Removing the sight glass, igniter, or flame sense rod.
4 mm Allen key	Removing the mixer from the gas train. Removing the burner access plate.
5 mm Allen key	Removing the cover plate to access heat exchanger interior.
8 mm socket or wrench	Removing cover plate insulation.
10 mm socket or wrench	Removing the burner.
11 mm socket or wrench	Removing the mixer from the silencer.
13 mm wrench	Removing the blower.
Multimeter	Measurement readings on sensors and electrical components.
Manometer (inclined or digital)	Measuring the gas pressure coming to the boiler.
Combustion analyzer (digital preferred)	Combustion testing.
Contact thermometer	Checking surface temperatures of the heat exchanger and pipes.

Abbreviations

Table 2 Common abbreviations

Abbreviation	Description
AMP	Ampere or Amperage
ANSI	American National Standards Institute
ASME	American Society of Mechanical Engineers
BTUH	British Thermal Unit per Hour
CH	Comfort Heat
CO	Carbon Monoxide
CO ₂	Carbon Dioxide
CP	Consumer Protection
CPVC	Chlorinated Polyvinyl Chloride
CSA	Canadian Standards Association
CSD-1	Controls and Safety Devices
DHW	Domestic Hot Water
LP	Liquefied Petroleum (Propane)
LWCO	Low Water Cut-Off
MBH	Thousands of Btuh
NFPA	National Fire and Protection Agency
NG	Natural Gas
NIOSH	National Institute for Occupational Safety and Health
NTC	Negative Temperature Coefficient
O ₂	Oxygen
ODT	Outdoor Temperature
P/T	Pressure and Temperature
RPM	Revolutions Per Minute
SCFM	Standard Cubic Feet per Minute
TB<#>	Terminal Block (1, 2, 3, etc.)
ULC	Underwriters Laboratories of Canada
VAC	Volts Alternating Current
VDC	Volts Direct Current
W.C.	Water Column



SECTION 1

Safety

This section is intended to provide safety information for installers and users.

Section Contents

Safety Signals	5
Please Read Before Proceeding	5

Safety Signals

The following defined terms are used throughout this manual to bring attention to the presence of hazards or other important information.

⚠ DANGER

Danger indicates the presence of hazards that will result in severe personal injury, death, or substantial property damage.

⚠ WARNING

Warning indicates the presence of hazards that can result in severe personal injury, death, or substantial property damage.

⚠ CAUTION

Caution indicates the presence of hazards that will or can result in minor personal injury or property damage.

NOTICE

Notice indicates additional information that may be related to property damage, but is not related to personal injury.

IMPORTANT

Important indicates additional information that is important, but is not related to personal injury or property damage.

Please Read Before Proceeding

⚠ WARNING

Adhere to all following guidelines and instructions in this section. Failure to adhere to these guidelines can result in severe personal injury, death, or substantial property damage.

Installer: Read all instructions, including this manual and all other information shipped with the boiler, before installation. Perform steps in the order given. Consider piping and installation when determining boiler location.

User: This manual is for use only by a qualified heating installer or service technician. Refer to the User Manual (part number 550100291) for your reference. A qualified service technician should inspect and service this boiler at least once per year.

Write the Consumer Protection (CP) number and serial number in the space provided on the Installation and Service Certificate on [page 124](#). The CP number can be found on the boiler jacket.

Please include the boiler model number, CP number, and serial number when calling or writing about the boiler. The model number can be found on the boiler rating label.

IMPORTANT

Any claims for damage or shortage in shipment must be filed immediately against the transportation company by the consignee.



Please Read Before Proceeding, continued

Servicing a Boiler

- To avoid electric shock, disconnect all electrical supplies to the boiler before performing maintenance.
- To avoid severe burns, allow boiler to cool before performing maintenance.
- This boiler contains ceramic fiber and fiberglass materials. Refer to the warning and instructions on [page 91](#).

Boiler Operation

- Do not block flow of combustion or ventilation air to boiler.
- Should overheating occur, or gas supply fail to shut off, do not turn off or disconnect electrical supply to pump. Shut off the gas supply at a location external to the appliance.

Boiler Water

- Since the heat exchanger is made of stainless steel, the water chemistry must be checked. The system pH must be in the range of 7.0 to 8.5. Chemical treatment may be required. See pages [79](#) to [81](#) for details.
- Before connecting the boiler, thoroughly flush the system to remove sediment. Install a strainer or other sediment removal equipment if necessary. The high-efficiency heat exchanger can be damaged by build-up or corrosion due to sediment.
- Do not use petroleum-based cleaning or sealing compounds in the boiler system. Gaskets and seals in the system may be damaged, which can result in substantial property damage.
- Continual fresh make-up water will reduce boiler life. Mineral buildup in the heat exchanger reduces heat transfer, overheats the stainless steel heat exchanger, and causes failure. Addition of oxygen carried in by make-up water can cause internal corrosion. Leaks in the boiler or piping must be repaired at once to prevent make-up water. Use this boiler ONLY in a closed-loop system.
- Do not add cold water to a hot boiler. Thermal shock can cause the heat exchanger to crack.

Commonwealth of Massachusetts

When the boiler is installed within the Commonwealth of Massachusetts:

- This product must be installed by a licensed plumber or gas fitter.
 - If antifreeze is used, a reduced pressure back-flow preventer device shall be used.
- See [page 28](#) for sidewall vent air installations.

Freeze Protection Fluids

NEVER use automotive or standard glycol antifreeze, including glycol made for hydronic systems. Use only freeze-protection fluids recommended in this manual. See [page 80](#) for more information. Thoroughly clean and flush any replacement boiler system that has used glycol before installing the new SVF boiler.

Damage from Water Contact

⚠ DANGER

DO NOT attempt to operate any boiler if any part of the boiler, burner, or controls has been partially or fully sprayed with or submerged under water. The boiler must either be replaced or completely repaired and inspected. The boiler and all components must be in good condition and fully reliable before operation.

If these requirements are not met, operating the boiler will cause fire, explosion, and electrical shock hazards, leading to serious injury, death, or substantial property damage.

Saltwater damage: The immediate effects of saltwater damage are like those of freshwater, with electrical components shorting out and the removal of critical lubricants. However, salt and other contaminants left behind can lead to long term issues due to the conductive and corrosive nature of salt residue. WM Technologies equipment contaminated with saltwater or polluted water will no longer be covered under warranty and should be replaced.

Electrical damage: If any electrical component or wiring has, or is suspected to have come into contact with water, replace the boiler.

Frozen Water Damage

Power outages, unattended residences or buildings, boiler component failures, or other electrical system failures in cold weather can result in frozen plumbing and water damage in a matter of hours. Consult with a boiler contractor or a home security agent to take preventative actions, such as installing a security system that operates during power outages, senses low temperature, and initiates an effective action.

This page intentionally left blank

SECTION 2

Installation

This section is intended to provide installation instructions for qualified heating installers.

Section Contents

Prepare Boiler Location	9
Prepare the Boiler	14
Install Water Piping	19
Commonwealth of Massachusetts Installations	28
Venting and Combustion Air - General	29
Venting and Combustion Air Options	33
DIRECT EXHAUST - Room Air Openings (Cat. II and IV)	38
DIRECT EXHAUST - Vertical Termination (Cat. II and IV)	40
DIRECT EXHAUST - Sidewall Termination (Category IV)	42
DIRECT VENT - Room Air Openings (Category IV)	45
DIRECT VENT - Vertical Termination (Category IV)	48
DIRECT VENT - Sidewall Termination (Category IV)	52
Install Condensate Components	55
Gas Piping	56

Prepare Boiler Location

Installation Compliance Requirements

⚠WARNING

Installation and service must be performed by a qualified installer, service agency, or gas supplier. Install the equipment in accordance with this manual to avoid an unsafe operating condition, which can result in severe personal injury, death, or substantial property damage.

- Local, state, provincial, and national codes, laws, regulations, and ordinances.
- National Fuel Gas Code – ANSI Z223.1/NFPA 54, latest edition.
- National Electrical Code – ANSI/NFPA 70, latest edition. For Canada, electrical installation and grounding must be in accordance with Canadian Electrical Code, Part 1 – CSA C22.1, and local codes.
- For Canada only: Natural Gas and Propane Installation Code – CAN/CSA B149.1, and local codes.

- Where required by the authority having jurisdiction, the installation must conform to the Standard for Controls and Safety Devices for Automatically Fired Boilers – ANSI/ASME CSD-1, latest edition.

IMPORTANT

The SVF boiler manifold and controls met safe lighting and other performance criteria when the boiler underwent tests specified in ANSI Z21.13, latest edition.

Checks Before Boiler Installation

1. Check for nearby connections to:
 - System water piping
 - Venting connections
 - Gas supply piping
 - Electrical Power
 - Location of drain for condensate
2. Check area around boiler. Remove any combustible materials, gasoline, and other flammable liquids.

⚠WARNING

Failure to keep boiler area clear and free of combustible materials, gasoline, and other flammable liquids and vapors can create an explosion hazard, which can result in severe personal injury, death, or substantial property damage.

3. Check the boiler location to ensure it protects the gas control system components from dripping or spraying water and rain during operation or service.
4. If a new boiler is replacing the existing boiler, check for and correct system problems:
 - System leaks causing oxygen corrosion or heat exchanger cracks from hard water deposits.
 - Incorrect expansion tank sizing.
 - Lack of freeze protection in boiler water.



Prepare Boiler Location, continued

Flooring and Foundation

The SVF Boiler is approved for installation on combustible flooring, but must never be installed on carpeting.

2 **⚠WARNING**

Do not install the boiler on carpeting even if a foundation is used. Installing a boiler on carpeting can cause a fire, which can result in severe personal injury, death, or substantial property damage.

1. The boiler mounting surface must be level and suitable for the load.
2. Provide a solid foundation pad at least 2" (51 mm) above the floor if any of the following is true:
 - Floor can become flooded.
 - The floor is dirt, sand, gravel, or other loose material.
 - The boiler mounting area is severely uneven or sloped.
3. Foundation may be brick or concrete construction. The minimum foundation dimensions are listed in Table 3.
4. If flooding is possible, elevate the boiler sufficiently to prevent water from reaching the boiler.

Garage Installation

Take the following special precautions when installing the boiler in a garage.

1. Mount the boiler at a height above the floor as specified in the latest edition of the National Fuel Gas Code – ANSI Z223.1/NFPA 54 for U.S. installations. For Canadian installations, use the Natural Gas and Propane Installation Code – CAN/CSA B149.1.
2. Locate or protect the boiler so it cannot be damaged by a moving vehicle.
3. Ensure that the installation complies with all applicable codes.

Table 3 Minimum foundation dimensions

Boiler Model	Minimum Dimensions (inches)
SVF 725	29 x 44 x 2
SVF 850	29 x 44 x 2

Openings

Openings in floors, walls, ceilings, or roofs must be designed for fire stopping as required by local codes.

Vent pipe openings through combustible materials must be 3/8" (9.5 mm) larger in diameter than the vent pipe.

Air pipe openings should be 3/8" (9.5 mm) larger in diameter than the pipe or as required by the pipe manufacturer.

⚠WARNING

Pipe openings that do not have the required diameter can cause a fire, which can result in severe personal injury, death, or substantial property damage.

Provide air openings for combustion air and ventilation of the room. See [page 12](#) for more information.

Clearances

Hot water pipes, vent pipes, and piping ends all have a minimum clearance requirement from combustible surfaces. There are also minimum allowable service clearances and recommended service access clearances. See Figure 1 for all clearances.

IMPORTANT

Without the recommended minimum clearances for service access, it may not be possible to service the boiler without removing it from the space.

Figure 1 Clearances for SVF Boilers

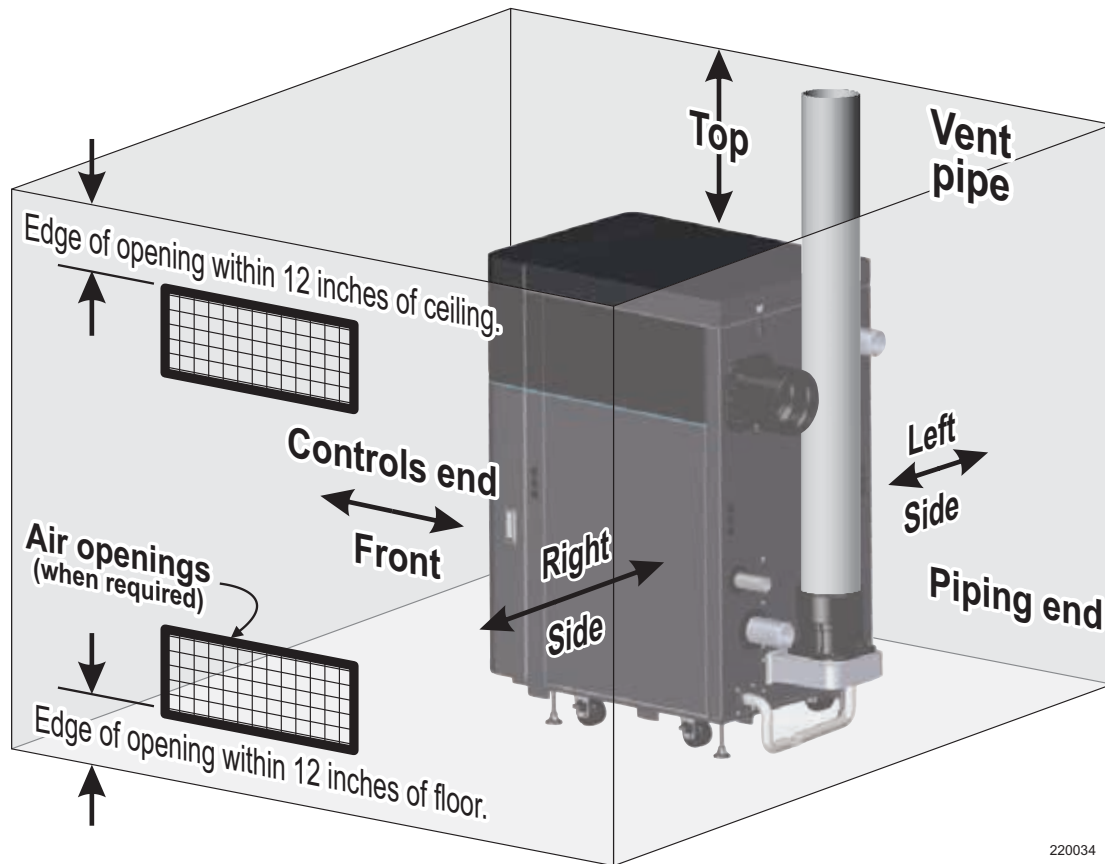

Ensure that the installation complies with all state, local, and applicable codes.

Clearance from:	Minimum clearances to combustible surfaces (inches)	Minimum allowable service clearances (inches)	Recommended minimum service access clearances (inches)
Controls end (Front)	0	24	35
Left side	0	0*	24*
Right side	0	0*	24*
Piping end	18	18	35 (Measured from frame, not pipes)
Top	0	18**	18**
Floor	0	—	—
Vent pipe	3/16	—	—
Hot water pipes	1/2	—	—

* Boiler can be installed next to another boiler. Clearances shown allow for easier service and maintenance.

** Top clearance allows for access to the cover plate for burner and heat exchanger service.

Prepare Boiler Location, continued

Air Openings - General

Follow the National Fuel Gas Code – ANSI Z223.1/ NFPA 54, latest edition, for the U.S. Follow the Natural Gas and Propane Installation Code – CAN/CSA B149.1 for Canada.

Follow all applicable codes to size and verify size of the combustion and ventilation air openings into the space.

The SVF boiler requires a special vent system. See the Venting and Combustion Air sections starting on [page 29](#) for more information on the venting methods, and the required air openings and sizing for direct vent or direct exhaust installations.

SVF Boiler Alone in Boiler Room:

Direct Vent installations: No air ventilation openings into boiler room are needed if the clearances around the boiler are at least equal to the recommended service clearances shown in [Figure 1, page 11](#). For spaces that do not supply the recommended minimum service access clearances, see the direct vent instructions for required openings for venting starting on [page 45](#).

Direct Exhaust installations: Provide air openings as specified in the Direct Exhaust - Room Air Openings section, starting on [page 38](#).

SVF Boiler in a Room With Other Appliances:

Direct Vent installations: Size openings only on the basis of the other appliances in the space. No additional air opening free area is needed for the SVF boiler because it takes its combustion air from outside.

⚠ WARNING

For direct vent installations where the boiler is located in the same room as other appliances, provide combustion air openings correctly sized for all appliances in the room EXCEPT the SVF boiler. Failure to comply can result in severe personal injury, death, or substantial property damage.

Direct Exhaust installations: Combustion air openings into the room must be sized to handle the SVF boiler and all other appliances. See the direct exhaust venting instructions starting on [page 38](#) for required openings.

The boiler control has the ability to operate a combustion air damper. Refer to section D on [page 67](#) and the SVF Advanced Manual (part number 550-100-292).

⚠ WARNING

For direct exhaust installations, provide combustion air openings correctly sized for all appliances in the room, INCLUDING the SVF boiler. Failure to comply can result in severe personal injury, death, or substantial property damage.

Preparing for Multiple Boilers

1. Provide the clearances shown in Figure 2 and follow local codes. Other layouts can be used if all required clearances are maintained.
2. Construct boiler foundation if the floor in the boiler room is uneven or if there is the probability of flooding. Size foundation to allow for clearance and spacing dimensions shown in the figure below.
3. Chalk-line boiler locations on foundation or boiler room floor.
4. Remove boilers from the crate and assemble according to instructions in this manual.
5. Provide clearance for installation of venting, air piping, gas piping, condensate piping and components, expansion tank, boiler pump, and other accessories as given in [Figure 1, page 11](#).

Figure 2 Side-to-side mounting of multiple boilers

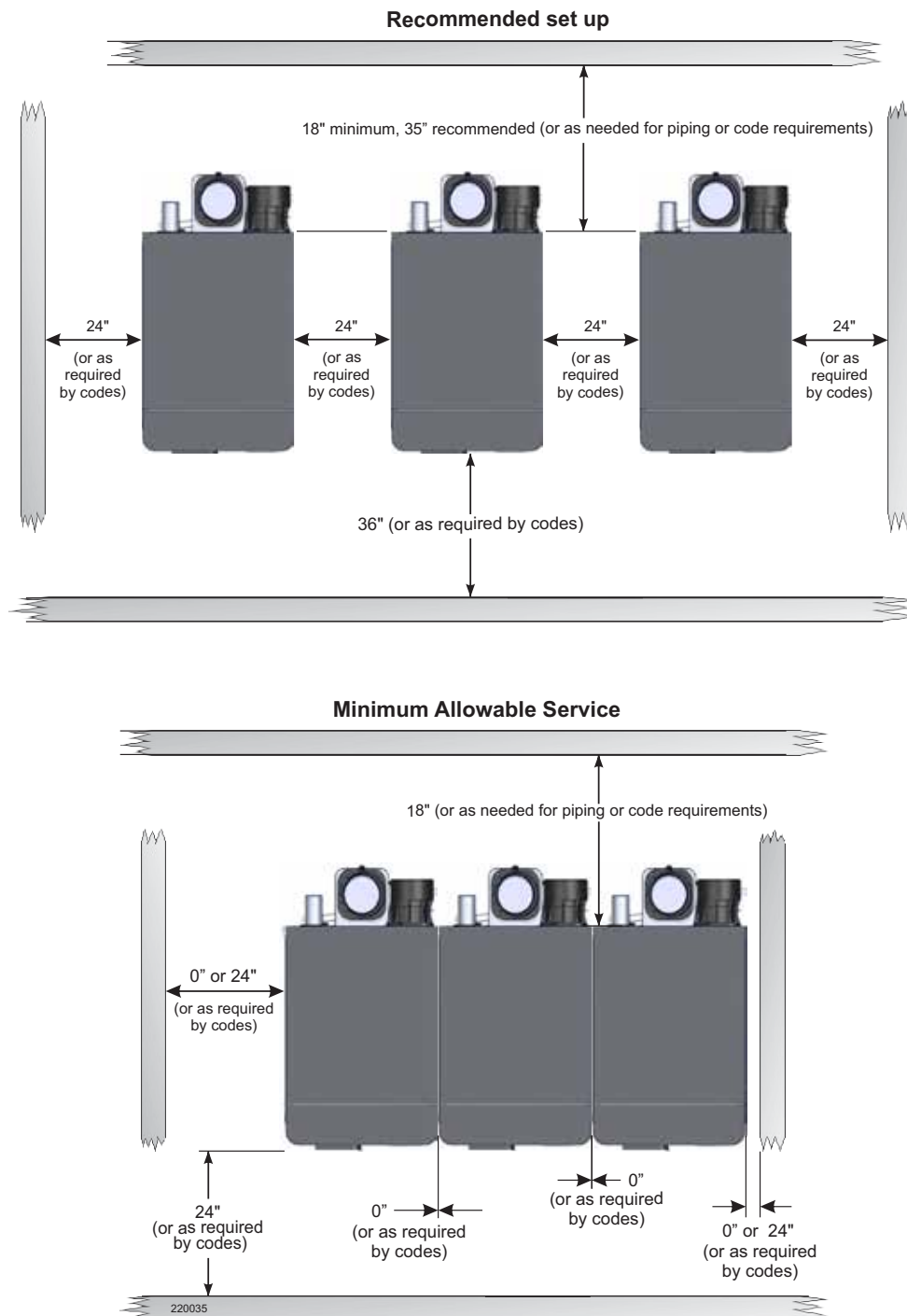

Prepare the Boiler

Removing the Boiler from the Crate

Leave the boiler in the crate pallet until ready to place in the final location. Follow all uncrating instructions. Refer to Figure 3 for the following instructions.

NOTICE

If the boiler has been stored in a location with temperatures below 32°F (0°C), handle with care until the plastic components come to room temperature.

NOTICE

Leave the plastic covers on the connections and adapters until ready to attach piping. This will protect the fitting surfaces from damage and prevent debris from entering the vent or air adapters.

1. Move the crate to a solid, level surface. The crate must sit securely on the ground. Ensure there is sufficient clearance for the crate, ramp, and final boiler placement on the floor in front of the piping.

⚠ WARNING

The boiler is heavy. Use caution not to drop the boiler. Use proper lifting equipment and techniques. Do not lift the boiler with water or gas pipes. Do not handle, apply weight to, or push on the gas pipes. Failure to comply can result in severe personal injury, death, or substantial property damage.

2. Remove the ramp from the crate. Place the end of the ramp into the notch in the pallet as show in Figure 3. Follow the uncrating instruction label to secure the ramp to the pallet.
3. Remove board at ramp end that states "REMOVE TO UNLOAD" with crowbar or claw hammer.
4. Remove the eight screws and eight lag bolts from the four shipping brackets.

Figure 3 SVF boiler on pallet with ramp in position

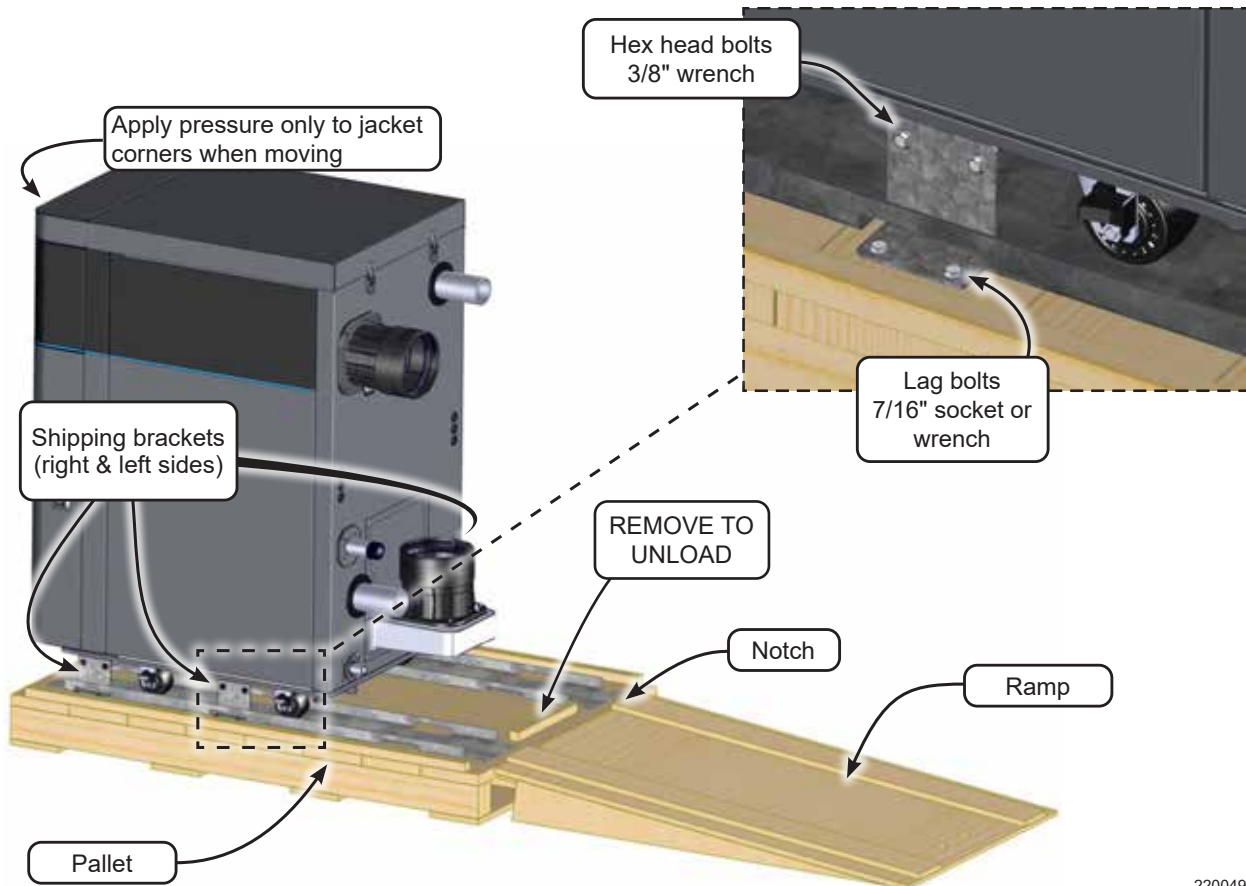

220049

Placing the Boiler

1. Roll the boiler down the ramp and move the boiler into position. The boiler must be unloaded from the pallet onto a solid, level surface.

⚠ WARNING

*The boiler is heavy. Use caution when rolling down the ramp. When moving the boiler, apply pressure **ONLY** at the jacket corner posts or water manifolds. Handling the boiler improperly can result in severe personal injury, death, or substantial property damage.*

2. The front two casters are swivel type, while the back two casters are fixed. Take care to keep the boiler straight when rolling.
3. Adjust the leveling legs down until they are firmly in contact with the floor. Remove the jacket panels to access bolt heads and jam nuts for leveling the boiler.
4. Continue adjusting the legs until the bottom of the boiler base is 1/16" (1.6 mm) above the floor while keeping the boiler level. Check the level, front to back and side to side. Measure level on the cover plate. See Figure 4.

⚠ CAUTION

Do not rest the boiler on the casters. The casters are intended for moving the boiler into position only. The support legs must be extended to take the load off the boiler.

Bolting the Boiler to Mounting Blocks

For applications requiring bolting down of the boiler (such as earthquake zone requirements), use the leveling legs to position the boiler until the bottom of the boiler base is 1/16" (1.6 mm) above the floor. The four brackets used as seismic mounting brackets are also used as shipping brackets. Reattach these brackets with the eight screws and eight lag bolts once the boiler is in place. See [Figure 3, page 14](#) and [Figure 5](#) for details. Refer to the seismic calculations document for additional information.

⚠ WARNING

Follow all applicable codes and recognized engineering design practices to verify the final mounting will meet all seismic, structural, and other requirements. Failure to comply can result in severe personal injury, death, or substantial property damage.

Figure 4 Leveling legs warning



Figure 5 Seismic mounting brackets (provided by others)

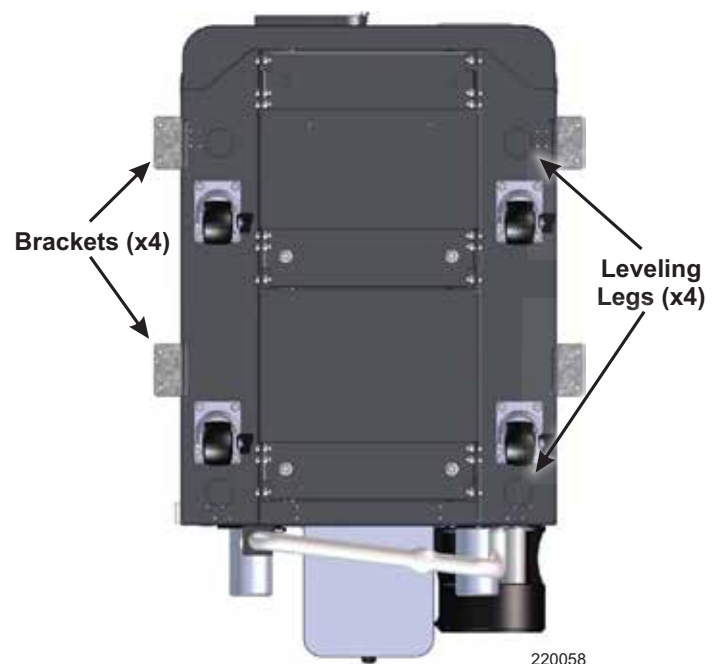

Prepare the Boiler, continued

Propane Conversion Procedure (when required)

PROPANE (LP) DESIGN AVAILABILITY PENDING

All SVF boilers are shipped ready for natural gas operation. The boilers must be fitted with a propane orifice and propane mixer to be used with propane. A conversion kit to convert the boiler to propane is purchased separately. See Miscellaneous Parts on page 111. To obtain the LP label kit, have the boiler serial number and call customer service before installation; reference part number 3840003889.

⚠WARNING

This conversion kit shall be installed by a qualified installer, service agency, or the gas supplier in accordance with the manufacturer's instructions and all applicable codes and requirements of the authority having jurisdiction. If the information in these instructions is not followed exactly, a fire, and explosion, or production of carbon monoxide can result causing property damage, personal injury, or loss of life. The qualified installer, service agency, or the gas supplier is responsible for the proper installation of this kit. The installation is not proper and complete until the operation of the converted appliance is checked as specified in the manufacturer's instructions supplied with the kit.

⚠WARNING

Turn off electrical supply to installed boilers before service. Close the external manual gas shut-off valve to isolate the boiler during conversion. Allow the boiler to cool if it has been operating. Failure to follow these instructions can result in severe personal injury, death, or substantial property damage.

1. Shut off power to the boiler before service.
2. Locate the propane orifice plate and the propane mixer from the conversion kit bag.
3. Verify that the stamping on the orifice plate is correct for the model size. There is one orifice for the SVF 725/850 boiler. The orifice size is 0.559".
4. Verify the orifice sizes on the mixer. The top orifice is 7.4 mm and the bottom orifice is 9.4 mm.
 - a. Ensure the label on the mixer reads:
 - VenturiØ: 50
 - InjØ: 940/740

Figure 6 Propane orifice location

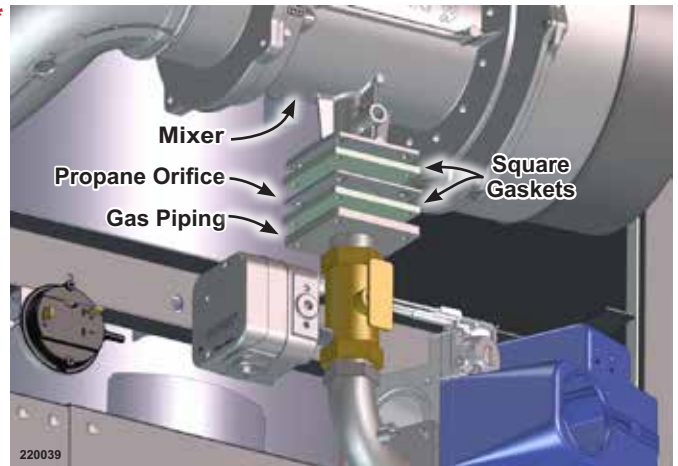

⚠WARNING

The propane orifice size marking must match the required boiler orifice size. Incorrect sizing can cause leaking gas fumes, which can result in severe personal severe personal injury, death, or substantial property damage.

5. Make a coarse throttle adjustment to the gas valve.
 - a. Carefully tighten the throttle screw until it bottoms out.
 - b. Back the screw out 1 and 3/4 turns.
6. Remove the two top panels from the boiler and set aside. Remove the side panels for easier access.
7. Using two 8 mm wrenches, remove the four bolts holding the silencer to the mixer.
8. Using two pipe wrenches, disconnect the gas flex line from the inlet pipe of the automatic gas valve.
9. Using an 8 mm wrench and 4 mm Allen wrench, remove the four bolts holding the gas pipe to the bottom of the mixer. A gasket will come free.
10. Remove the mixer with O-ring from the blower with a 13 mm wrench. Set the mixer aside. Ensure the O-ring is in good condition. Replace if necessary.
11. Take the propane mixer from the kit and install it to the blower. Ensure that the gas hookup is in the down orientation, and the O-ring is seated properly between the blower and mixer. Use a 13 mm wrench to secure the three nuts to the studs that hold the mixer to the blower. These blower studs should be equally spread out at 120° intervals, at the 12, 4 and 8 o'clock positions. Tighten to 87 in-lbs (9.82 Nm).

Propane Conversion Procedure, continued***PROPANE (LP) DESIGN AVAILABILITY PENDING***

12. Install the propane orifice between the gas pipe and the bottom of the mixer, wedged between the two square gaskets supplied with the propane conversion kit. See Figure 6. Secure the gas pipe to the mixer with an 8 mm wrench and a 4 mm Allen wrench and tighten to 44 in-lbs (5 Nm).
13. Install the silencer to the mixer. Secure the silencer with the four previously removed bolts using two 8 mm wrenches. Tighten to 44 in-lbs (5 Nm).
14. Reconnect the gas flex line to the inlet pipe of the automatic gas valve.
15. Apply the conversion label next to the rating label.
16. Reconnect the power to the boiler.
17. Remain at the powered boiler and call Tech Services to change the control to LP settings.

Test the boiler completely after conversion. Fill out the Fire Test label with the test results. Follow all instructions in this manual to start up the boiler. Check combustion levels and verify operation of the boiler and all system components after conversion.

High Altitude Installations

For high altitude installations (over 2,000 ft.), maximum blower, minimum blower, and ignition RPMs must be updated according to [Table 14, page 107](#).

If using propane as the input gas, target CO₂ values must also be adjusted according to the table. See instructions for changing the fan speed settings starting on [page 75](#). Make sure the boiler is converted to propane per the instructions on [page 16](#).

Pressure Test Preparation

Do not install the relief valve until pressure testing is complete. See Relief Valve Installation on [page 20](#) for installation instructions and warnings.

IMPORTANT

Apply pipe dope on all connections in the following steps. Use pipe dope sparingly.

Reference Figure 7 for the following steps. All components in this section are provided by the installer except a 30psig relief valve and the P/T gauge.

1. Remove the relief valve if it is installed.

Figure 7 Hydrostatic test piping connections - flanges, valves, and gaskets provided by installer

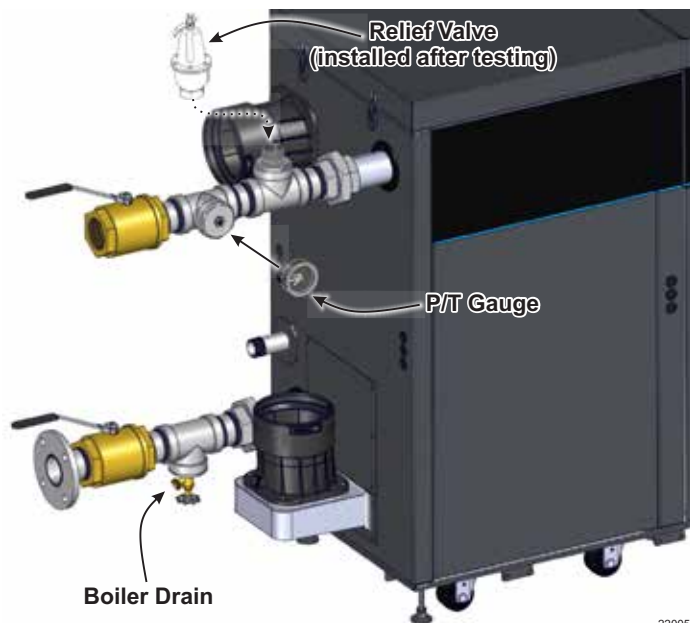

2. On the boiler supply pipe, install two tees as shown in Figure 7. Orient the tee closest to the boiler up into a vertical position. Install the second tee in a horizontal position.
 - a. The tee in the vertical position is where the relief valve will be installed after the pressure test. Install an NPT plug in this location for the pressure test.
 - b. The tee in the horizontal position is where the P/T gauge is installed for testing and for normal boiler operation.
3. Install a shutoff valve on the supply side and connect it to the rest of the system piping.
4. Install a drain valve and a shutoff valve on the boiler return pipe before connecting to the rest of the system piping. See Figure 7 for the boiler drain location.
5. If the pressure test is conducted with a pressure over 160 psig, remove the automatic air vent located inside the boiler cabinet on the heat exchanger port; replace it with a 1/2" NPT plug.

Prepare the Boiler, continued

Pressure Test Precautions

⚠ WARNING

Failure to comply with these precautions can result in severe personal injury, death, or substantial property damage.

All air MUST be purged out of the heat exchanger before performing the hydrostatic pressure test.

The test pressure MUST NOT exceed the maximum pressure on the P/T gauge. If the test pressure is going to exceed the maximum range of the current P/T gauge, use an appropriate gauge for the test.

Leaks must be repaired immediately. Leaks can damage the boiler, leading to substantial property damage.

DO NOT leave the boiler unattended at any time during testing. A cold water fill could expand and cause excessive pressure, resulting in severe personal injury, death, or substantial property damage.

The release of high pressure water should be done in a safe manner. Failure to release the water safely can result in severe personal injury, death, or substantial property damage.

DO NOT use petroleum-based cleaning or sealing compounds in the boiler system. Gaskets and seals in the system may be damaged, resulting in substantial property damage.

Fill the Boiler

1. Open the shutoff valves installed on the supply and return connections.
2. Allow water to flow into the bottom connection and air to flow out the top connection.
3. When water reaches the shutoff valve on top, allow water to flow long enough to ensure all air is out of the heat exchanger.
4. Close the shutoff valves on supply and return lines.
5. Close off the water supply.

Perform Hydrostatic Pressure Test

1. Use the hand pump to raise water pressure for testing.
2. The test pressure should be 1.5 times the pressure setting of the relief valve.
3. Gradually apply pressure until test pressure is reached. Test pressures are shown in Table 4 and are compared to the normal operation of the boiler with the pressure relief valve installed.
4. Hold at test pressure for 10 minutes.
5. Maintain constant gauge pressure throughout the test.

Table 4 Test pressure

Relief Valve Pressure	Test Pressure
30 psig	45 psig
50 psig	75 psig
100 psig	150 psig
160 psig	240 psig

6. Check for leaks. Repair any leaks from threaded joints. If leaks are found in the heat exchanger, consult your WM Technologies representative.
7. Slowly release pressure and drain.
8. Install the automatic air vent if removed.

Install Water Piping

General Piping Information

NOTICE

Use two wrenches when tightening water piping at the boiler with one at the boiler interior piping to prevent it from turning. Failure to prevent boiler piping connections from turning could cause damage to boiler components.

Additional controls, when required:

The control module uses temperature sensors to provide both high limits protection and operating limit control. The module is UL353 Limit Controls certified to meet ASME CSD-1 and Section IV requirements. A manual reset of the equipped low water cut-off (LWCO) is performed through the control module. Some codes and jurisdictions may require additional external controls.

Operating limit set point =
Supply Max. Temperature + Off Differential

Additional limit controls:

- Consult local requirements for other codes and standards to determine if additional limit devices are needed.
- The control provides two sets of limit control contacts. One set will cause automatic reset, while the other will cause manual reset of the control. See the Field Wiring section starting on [page 61](#) for wiring information.
- The control can be reset using the manual RESET function on the control display.

NOTICE

If the heating system includes circuits that require lower temperature water along with circuits that require higher temperature water, it is recommended to protect low-temperature circuits with limit controls that are wired to a manual or automatic reset circuit on the control.

Low water cutoff:

A push-to-test low water cutoff is factory installed on the switch panel on the left side of the control tray. The low water cutoff probe is mounted on the front of the heat exchanger.

The low water cutoff is manually reset through the main control. This can be performed through the display by selecting RESET LOCKOUT.

Backflow preventer:

Use a backflow check valve in the water fill as required by local codes.

Pressure and Temperature Gauge

The boiler is shipped with a 1/4" NPT pressure and temperature (P/T) gauge. The gauge has a pressure range up to 75 psig. This gauge meets ASME requirements for a relief valve setting of up to 50 psig.

The P/T gauge is mounted in a horizontal tee on the boiler supply outlet pipe. Installer must supply a tee connected to the system supply that has the correct sizing for the necessary P/T gauge. See [Figure 7, page 17](#) for placement details.

Install Water Piping, continued

Relief Valve Installation

⚠WARNING

Do NOT install a relief valve with a pressure higher than 160 psig. This is the maximum allowable relief valve setting for the SVF boiler. The boiler is shipped with a 30 psig relief valve. Failure to comply can result in severe personal injury, death, or substantial property damage.

⚠WARNING

Improper installation of the relief valve and discharge line can cause water damage and scalding. Follow all instructions and guidelines in this manual. Failure to comply can result in severe personal injury, death, or substantial property damage.

1. A 30 psig relief valve is shipped with the boiler. The valve must be installed by a qualified installer. The valve should be connected as close to the boiler water outlet as possible.
 2. Connect discharge piping to a safe disposal location according to the guidelines below.
- Discharge line must be connected to the relief valve outlet and run to a safe place of disposal. Terminate the discharge line in a manner that will prevent the possibility of severe burns or property damage should the valve discharge.
 - Discharge line must be as short as possible and be the same diameter as the valve discharge connection throughout its entire length.
 - Discharge line must pitch downward from the valve and terminate at least 6" above the floor drain where any discharge will be clearly visible.

Figure 8 Relief Valve Installed

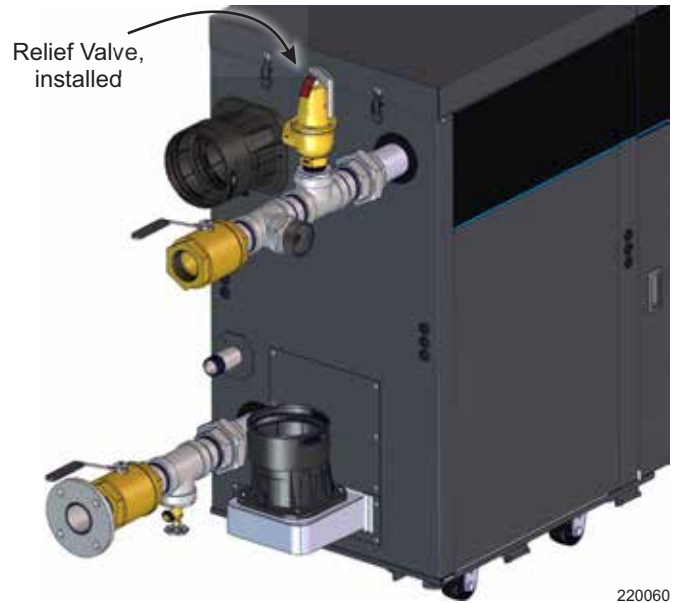

220060

- Discharge line shall terminate plain, not threaded, with a material serviceable for temperatures of 375°F (191°C) or greater.
- Do not pipe the discharge to any place where freezing could occur.
- Do not install any shutoff valve between the relief valve and boiler, or in the discharge line. Do not plug or place any obstruction in the discharge line.
- After filling and pressurizing the system, test the operation of the valve by lifting the lever. Make sure the valve discharges freely. If the valve fails to operate correctly, replace it with a new relief valve.

Pipe Sizing

Size the piping and the pumps to provide the required temperature rise. See Figure 9 for boiler head loss curves. See Table 5 for maximum and minimum flow rate through the boiler and head loss versus flow rate.

NOTICE

Pipe sizing should be based on the desired temperature rise for the system, corresponding to the recommended maximum flow rate. Failure to follow these guidelines can result in system issues.

NOTICE

DO NOT design the piping and components for a boiler flow rate above or below the ranges given in Table 5 without using one of the piping strategies listed below. Insufficient flow will cause nuisance outages due to limit operation. Excessive flow can damage the boiler heat exchanger from erosion.

Size system piping per Table 6, or apply recognized engineering practices to size the piping.

IMPORTANT

The SVF 725 and 850 boilers have 2-1/2" NPT male connections. Installer to provide reducers to adapt from external piping to the boiler supply and return connections if the system allows.

Higher flow rates than shown in Table 5:

- Use Primary/Secondary piping. See pages [24](#), [26](#), and [27](#).
- Add a differential pressure bypass valve to bypass the excessive flow in a Variable/Primary flow system, or provide an alternative engineering solution. See the figures on [page 25](#).

Lower flow rates than shown in Table 5:

- Use Primary/Secondary piping.
- In a Variable/Primary flow system, it is recommended to install a flow switch that is set at the minimum flow rate of the boiler. The variable circulator will increase water flow and prevent the boiler from firing with an insufficient flow rate. The higher water flow will make the flow switch contact, which will start the boiler.

Figure 9 Pressure drop versus flow rate for SVF boilers

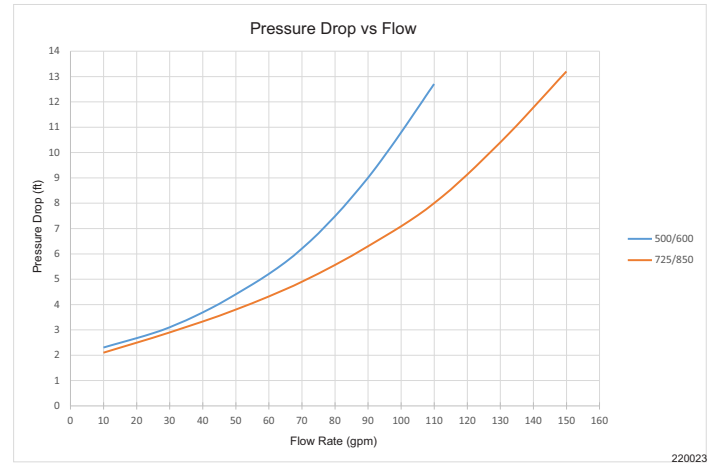

Table 5 Flow rate and pressure drop data

SVF 725			
Minimum Water Pressure	GPM	100% Rate	Boiler Head Loss (Feet W.C.)
		Temp Rise (°F)	
10 PSI	69	20	4.7
	55	25	3.9
	46	30*	3.5
	39	35	3.2
15 PSI	34	40****	3.0
	31	45****	2.9
	28	50****	2.8
	25	55****	2.7
	23**	60****	2.6
SVF 850			
Minimum Water Pressure	GPM	100% Rate	Boiler Head Loss (Feet W.C.)
		Temp Rise (°F)	
10 PSI	81	20	5.5
	65	25	4.5
	54	30*	3.9
	46	35	3.5
	40	40****	3.3
15 PSI	36	45****	3.1
	32	50****	2.9
	29	55****	2.8
	27***	60****	2.7

* Suggested design flow rate (30°F temp. rise, water only)
 **SVF 725 minimum flow rates (GPM): High Fire = 23, Low Fire = 4
 ***SVF 850 minimum flow rates (GPM): High Fire = 27, Low Fire = 4
 ****Temp Rises above 35°F are not recommended in high temp systems; larger Boiler Out on/off Diff's maybe required for proper operation

Table 6 Recommended pipe sizing per flow rate

Sch 40 Pipe Diameter	Maximum Flow Rate GPM	SCH 40 Pipe Diameter	Maximum Flow Rate GPM
2	45	6	800
3	140	8	1650
4	290		
5	500		

Install Water Piping, continued

Expansion Tank and Make-up Water

Ensure the expansion tank size will handle boiler and system water volume and temperature. See [Table 19, page 121](#) for boiler water content.

The expansion tank must be located as shown in this manual or per recognized design methods. See the tank manufacturer's instructions for details.

NOTICE

Undersized expansion tanks cause system water loss from the relief valve, and make-up water to be added through the fill valve. Boiler failure can eventually result due to the excessive addition of make-up water.

Connect the expansion tank to the air separator only if the separator is on the suction side of the pump. Always install the system fill connection at the same point as the expansion tank connection to the system.

Most piping drawings in this manual show diaphragm expansion tanks. See [Figure 11](#) for piping from the air separator to the expansion tank and make-up water line using a closed-type expansion tank.

Most chilled water systems are piped using a closed-type tank. Refer to [Figure 18, page 27](#).

Diaphragm or Bladder Expansion Tank

Always install an automatic air vent on top of the air separator to remove residual air from a system with a diaphragm or bladder expansion tank. See [Figure 10](#).

NOTICE

When the boiler is installed above the system main piping using diaphragm or bladder tanks, install an automatic air vent in the top of the outgoing boiler piping to prevent air pocketing.

NOTICE

The expansion tank needs to be charged to the required system fill pressure before being connected to the system.

Figure 10 Expansion tank piping - diaphragm-type tank

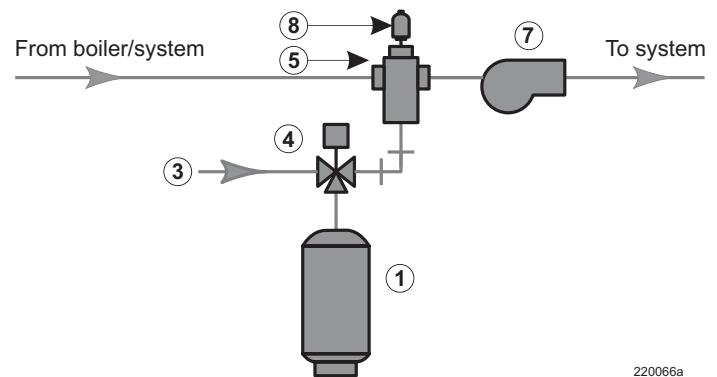
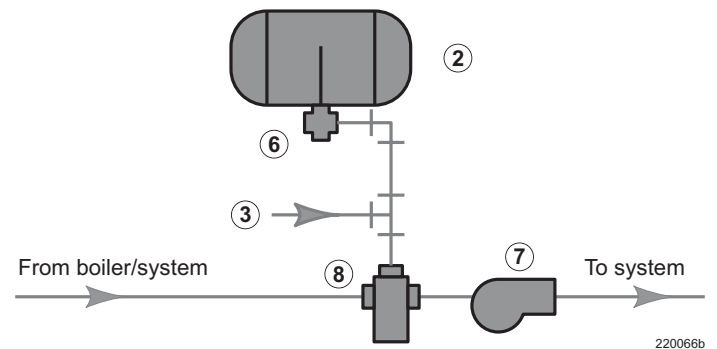

Figure 11 Expansion tank piping - closed-type tank



Legend – Figure 10 & Figure 11	
1. Diaphragm -type expansion tank	5. Air separator
2. Closed-Type expansion tank	6. Tank fitting
3. Make-up water line	7. System pump (when used)
4. Fill valve, typical	8. Automatic air vent

Closed-Type Expansion Tank

Refer to [Figure 11](#) for piping connections when using a closed-type expansion tank.

Pitch any horizontal piping up towards the tank. Pitch at 1" per 5 ft. of piping. Connect to the tank with at least 3/4" piping to allow room for air to rise.

NOTICE

DO NOT use automatic air vents on closed-type expansion tank systems. If there is an automatic air vent installed on the heat exchanger, remove it before operation. Air must remain in the system and return to the tank to provide its air cushion. An automatic air vent would cause air to leave system, resulting in water-logging the expansion tank.

ZONE VALVE Zoning - General

The information on this page applies to all zone valve zoning applications.

NOTICE

Use at least the minimum pipe size shown in [Table 6, page 21](#) on all boiler loop piping connecting the boiler to and from the primary/secondary connection (item 21 on the following pages). The primary/secondary piping shown on pages [24](#), [26](#), and [27](#) ensures the boiler loop will have sufficient flow.

Expansion tank required:

- Provide a system expansion tank following the guidelines on [page 22](#).
- DO NOT use a closed-type tank if connecting to a water heater that is equipped with an automatic vent.

Domestic hot water tank, if used:

1. For a domestic hot water (DHW) direct connection, pipe from the near-boiler piping to the DHW tank's boiler connections as shown on the following pages.
2. A DHW tank can be connected as a zone if a DHW tank is not already connected to the boiler. See the SVF Advanced Manual (part number 550-100-292) to configure Relay Output settings to run a boiler circulator during DHW demands, and to change settings to modulate based on Header Temperature Sensor (System Supply).
3. DHW PRIORITY TIMEOUT ENABLE defines if DHW PRIORITY operation can time out.
 - OFF - DHW operation always takes priority (no timeout).
 - ON - DHW operation takes priority until the DHW PRIORITY TIMEOUT timer expires. After this timer expires, the boiler can resume CH mode operation.

Controlling the pumps:

The control can control the boiler pump and up to three other pumps. Activation of the external pumps must be achieved by closing a relay.

Relay A is generally set to the boiler pump. Relays C and D can be set up according to system requirements. This setup is generally done when first installing the boiler by using the setup wizard on the control. To make changes after initial setup, select "Settings > All Parameters > Boiler Settings > Relay Association" from the home screen.

IMPORTANT

Connect zone valve end switches to a space heating priority input (default Priority 2) to use default settings. Connect the system pump to the corresponding output.

CAUTION

Use isolation relays if connecting 3-wire zone valve end switches to the inputs.

Install Water Piping, continued

ZONE VALVE Zoning - Primary/Secondary

IMPORTANT

Refer to [page 23](#) for general zone valve zoning information for all applications before installation.

This configuration is for zone valve systems using a boiler loop connected as a secondary circuit off a primary system loop. The primary/secondary piping shown in Figure 12 ensures the boiler loop will have sufficient flow. This piping also avoids applying the high head of the boiler circulator to the zone valves.

Install a system circulator (supplied by installer) capable of delivering the proper flow and head as shown.

The flow/check valve shown on the boiler outlet piping prevents gravity circulation in the boiler loop during DHW heating.

For other piping methods, see guidelines starting on [page 21](#).

ZONE VALVE Zoning - High-flow-rate or High-head-loss DHW Circuits

This configuration is for applications requiring DHW circuit flow rates higher than allowable for the boiler, or for high pressure drop coil-type DHW tanks.

Connect the piping as shown in Figure 13. The DHW water only flows through the secondary circuit connection piping. The primary/secondary piping shown ensures the boiler loop will have sufficient flow, and avoids applying the high head of the boiler circulator to the zone valves.

Size the connection piping (item 23) to handle the total flow it must handle.

Install a system circulator (supplied by installer) capable of delivering the proper flow and head.

The flow/check valve shown on the boiler outlet piping prevents gravity circulation in the boiler loop during DHW heating.

Figure 12 Zone valve zoning with optional DHW piping

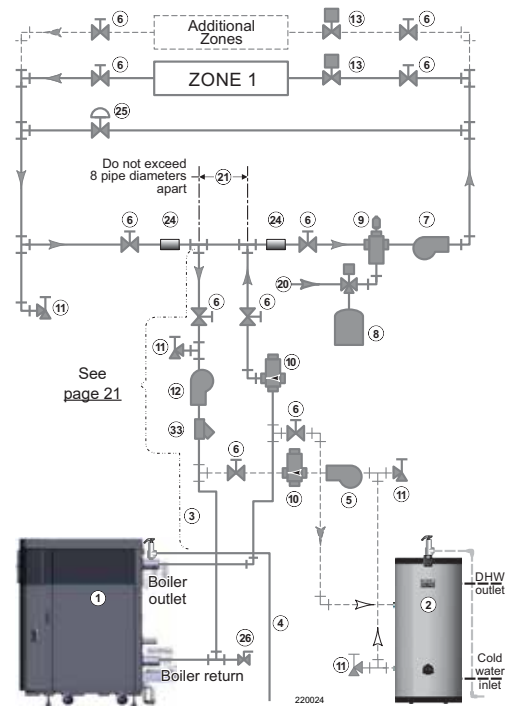
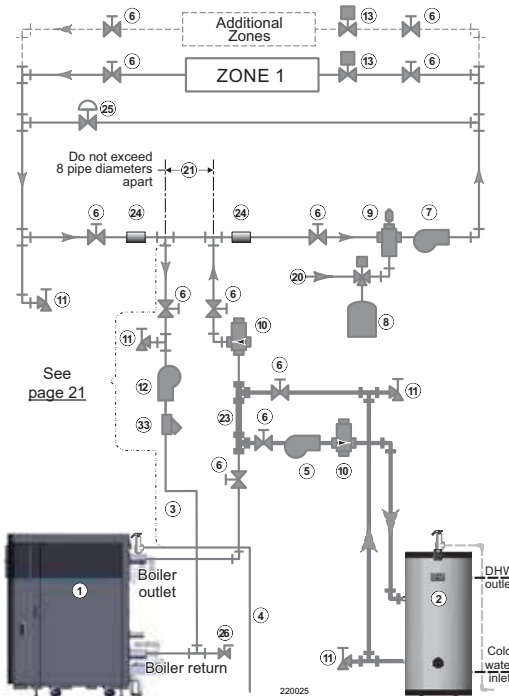

Figure 13 Zone valve zoning alternate with DHW piping



Legend – Figure 12 and Figure 13

1. SVF boiler	9. Air separator	23. DHW secondary connector piping; no more than eight pipe diameters apart
2. Indirect water heater (DHW), if used	10. Flow/check valves	24. System supply and return immersion sensors; at least six pipe diameters (but no more than 3 ft.) from boiler connection tees.
3. Boiler relief valve	11. Purge/drain valves	25. Bypass pressure regulator; for use in systems using high-head pumps that require a regulator to prevent damage to control valves.
4. Relief valve discharge piping	12. Boiler circulator	26. External drain/blowdown valve, when used
5. DHW circulator	13. Zone valves, typical	33. Strainer, recommended
6. Isolation valves	20. Make-up water supply	
7. System circulator	21. Primary/secondary connection; tees no more than eight pipe diameters apart	
8. Diaphragm or bladder type expansion tank		



Install Water Piping, continued

ZONE VALVE Zoning - Circulator Zoning, Primary/Secondary

IMPORTANT

Refer to [page 23](#) for general zone valve zoning information for all applications before installation.

This configuration is for circulator-zoned systems using a boiler loop connected as a secondary circuit off a primary system loop.

Install a separate circulator (supplied by installer) for each zone capable of delivering the proper flow and head as shown in Figure 16.

The flow/check valve shown on the boiler outlet piping prevents gravity circulation in the boiler loop during DHW heating.

ZONE VALVE Zoning - Radiant Heating, Primary/Secondary

The SVF boiler is ideal for use in radiant heating. The unique heat exchanger design allows the boiler to work well even in condensing mode. There is no need to regulate boiler return water temperature in radiant heating applications.

The primary/secondary piping shown in Figure 17 ensures the boiler loop will have sufficient flow. The piping also avoids applying the high head of the boiler circulator to the zone valves. Apply this configuration for typical radiant heating applications.

Size the system piping and circulators to provide the flow and pressure drop needed. The flow/check valve shown on the boiler outlet piping prevents gravity circulation in the boiler loop during DHW heating.

Figure 16 Pump zoning with optional DHW piping

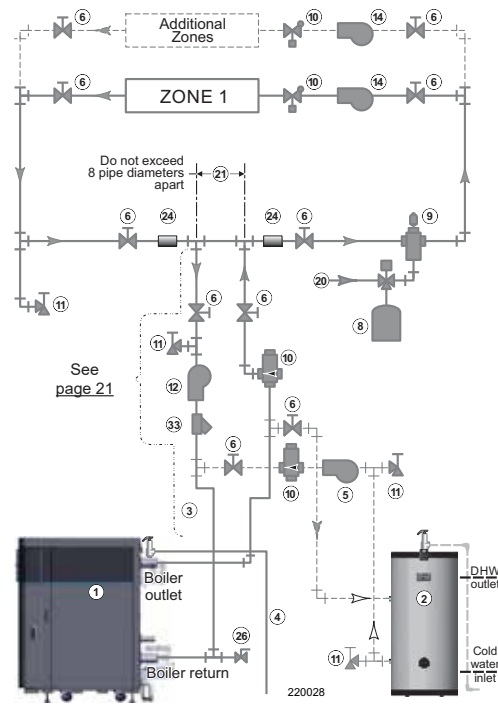
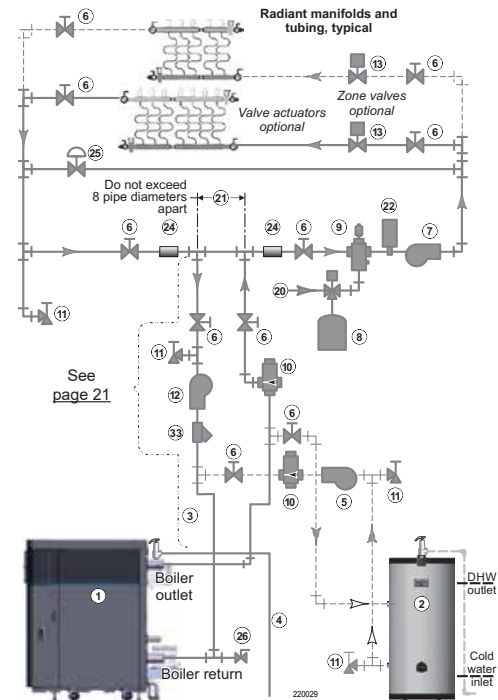

Figure 17 Radiant heating system with optional DHW



Legend – Figure 16 and Figure 17

1. SVF boiler	10. Flow/check valves	22. Optional high limit temperature control; set to protect radiant heating
2. Indirect water heater (DHW), if used	11. Purge/drain valves	24. System supply and return immersion sensors; at least six pipe diameters (but no more than 3 ft.) from boiler connection tees.
3. Boiler relief valve	12. Boiler circulator	25. Bypass pressure regulator; for use in systems using high-head pumps that require a regulator to prevent damage to control valves.
4. Relief valve discharge piping	13. Zone valves, typical	26. External drain/blowdown valve, when used
5. DHW circulator	14. Zone pumps, typical	33. Strainer, recommended
6. Isolation valves	20. Make-up water supply	
7. System circulator	21. Primary/secondary connection; tees no more than eight pipe diameters apart	
8. Diaphragm or bladder type expansion tank		
9. Air separator		

ZONE VALVE Zoning - Water Chiller Systems, Primary/Secondary

IMPORTANT

Refer to [page 23](#) for general zone valve zoning information for all applications before installation.

This configuration is for applications using a chilled water system. The chiller must be piped in parallel with the boiler. Use appropriate valves to prevent chilled medium from entering the boiler.

The space heating system can be zones with circulators if a separate circulator is supplied for the chilled water loop. Install a separate circulator for each zone.

The flow/check valve shown on the boiler outlet piping prevents gravity circulation in the boiler loop during DHW heating.

Chilled medium, if used, is piped in parallel with heating boiler as shown in Figure 18. Use appropriate valves to prevent chilled medium from entering the boiler.

NOTICE

If the boiler is connected to heating coils located in air handling units where they can be exposed to refrigerated air, use flow control valves or other automatic means to prevent gravity circulation during cooling cycle.

NOTICE

If antifreeze is used in the system, consider the effects of antifreeze on circulator sizing and DHW performance. Some local codes may require double-wall DHW heat exchanger design. Use only the antifreeze listed on [page 111](#) for use with this boiler.

Figure 18 Chilled water system with optional DHW piping

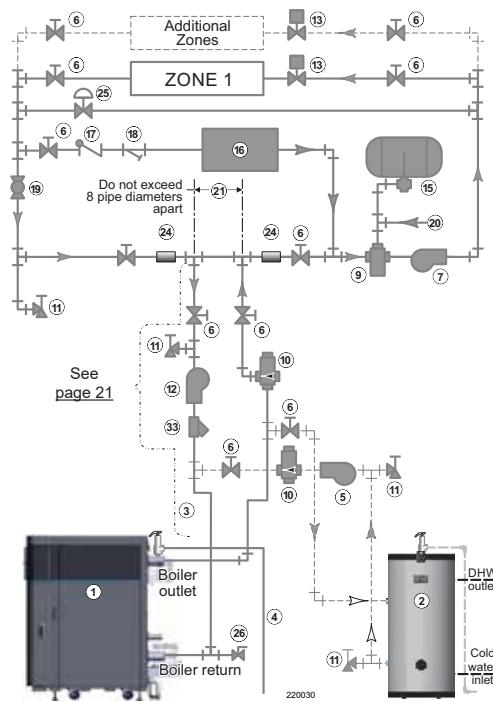

Legend – Figure 18

1. SVF boiler	12. Boiler circulator	21. Primary/secondary connection; tees no more than eight pipe diameters apart
2. Indirect water heater (DHW), if used	13. Zone valves, typical	24. System supply and return immersion sensors; at least six pipe diameters (but no more than 3 ft.) from boiler connection tees.
3. Boiler relief valve	15. Closed-type expansion tank	25. Bypass pressure regulator; for use in systems using high-head pumps that require a regulator to prevent damage to control valves.
4. Relief valve discharge piping	16. Water chiller	26. External drain/blowdown valve, when used
5. DHW circulator	17. Check valve	33. Strainer, recommended
6. Isolation valves	18. Strainer	
7. System circulator	19. Balancing valve	
9. Air separator	20. Make-up water supply	
10. Flow/check valves	21. Primary/secondary connection; tees no more than eight pipe diameters apart	
11. Purge/drain valves		



Commonwealth of Massachusetts Installations

Commonwealth of Massachusetts — When the boiler is installed within the Commonwealth of Massachusetts, the boiler must be installed by a licensed plumber or gas fitter. Read and comply with the instructions below.

1. **REQUIREMENTS:** For all sidewall horizontally-vented gas-fueled equipment installed in every dwelling, building or structure used in whole or in part for residential purposes, including those owned or operated by the Commonwealth and where the side wall exhaust vent termination is less than 7 feet above finished grade in the area of the venting, including but not limited to decks and porches, the following requirements shall be satisfied:
 - a. **INSTALLATION OF CARBON MONOXIDE DETECTORS.**
At the time of installation of the side wall horizontal vented gas fueled equipment, the installing plumber or gas fitter shall observe that a hard wired carbon monoxide detector with an alarm and battery back-up is installed on the floor level where the gas equipment is to be installed. In addition, the installing plumber or gas fitter shall observe that a battery operated or hard wired carbon monoxide detector with an alarm is installed on each additional level of the dwelling, building or structure served by the side wall horizontal vented gas fueled equipment. It shall be the responsibility of the property owner to secure the services of qualified licensed professionals for the installation of hard wired carbon monoxide detectors.
 - In the event that the side wall horizontally vented gas fueled equipment is installed in a crawl space or an attic, the hard wired carbon monoxide detector with alarm and battery back-up may be installed on the next adjacent floor level.
 - In the event that the requirements of this subdivision can not be met at the time of completion of installation, the owner shall have a period of thirty (30) days to comply with the above requirements; provided, however, that during said thirty (30) day period, a battery operated carbon monoxide detector with an alarm shall be installed.
 - b. **APPROVED CARBON MONOXIDE DETECTORS.** Each carbon monoxide detector as required in accordance with the above provisions shall comply with NFPA 720 and be ANSI/UL 2034 listed and IAS certified.
 - c. **SIGNAGE.** A metal or plastic identification plate shall be permanently mounted to the exterior of the building at a minimum height of 8 feet above grade directly in line with the exhaust vent terminal for the horizontally vented gas fueled heating appliance or equipment. The sign shall read, in print size no less than one-half (1/2) inch in size, "GAS VENT DIRECTLY BELOW. KEEP CLEAR OF ALL OBSTRUCTIONS."
 - d. **INSPECTION.** The state or local gas inspector of the side wall horizontally vented gas fueled equipment shall not approve the installation unless, upon inspection, the inspector observes carbon monoxide detectors and signage installed in accordance with the provisions of 248 CMR 5.08(2)(a) 1 through 4.
2. **EXEMPTIONS:** The following equipment is exempt from 248 CMR 5.08(2)(a)1 through 4:
 - a. The equipment listed in Chapter 10 entitled "Equipment Not Required To Be Vented" in the most current edition of NFPA 54 as adopted by the Board; and
 - b. Product Approved side wall horizontally vented gas fueled equipment installed in a room or structure separate from the dwelling, building or structure used in whole or in part for residential purposes.
3. **MANUFACTURER REQUIREMENTS — GAS EQUIPMENT VENTING SYSTEM PROVIDED.**
When the manufacturer of Product Approved side wall horizontally vented gas equipment provides a venting system design or venting system components with the equipment, the instructions provided by the manufacturer for installation of the equipment and the venting system shall include:
 - a. Detailed instructions for the installation of the venting system design or the venting system components; and
 - b. A complete parts list for the venting system design or venting system.
4. **MANUFACTURER REQUIREMENTS — GAS EQUIPMENT VENTING SYSTEM NOT PROVIDED.**
When the manufacturer of a Product Approved side wall horizontally vented gas fueled equipment does not provide the parts for venting the flue gases, but identifies "special venting systems", the following requirements shall be satisfied by the manufacturer:
 - a. The referenced "special venting system" instructions shall be included with the appliance or equipment installation instructions; and
 - b. The "special venting systems" shall be Product Approved by the Board, and the instructions for that system shall include a parts list and detailed installation instructions.
5. **PLASTIC VENTING SYSTEMS.**
The only plastic piping which may be used for venting appliances shall be:
 - a. Allowed by the appliance manufacturer.
 - b. Listed to a national/international standard for plastic venting systems.
 - c. Product-accepted for that purpose by the board.
6. **INSTALLATION INSTRUCTIONS.**
A copy of all installation instructions for all Product Approved side wall horizontally vented gas fueled equipment, all venting instructions, all parts lists for venting instructions, and/or all venting design instructions shall remain with the appliance or equipment at the completion of the installation.

Venting and Combustion Air - General

Code Compliance

Venting and combustion air piping installations must provide provisions in accordance with “Air for Combustion and Ventilation,” of the National Fuel Gas Code – ANSI Z223.1/NFPA 54, latest edition, or sections 8.2-8.4 of the Natural Gas and Propane Installation Code – CAN/CSA B149.1, and applicable local building codes.

⚠ DANGER

DO NOT common vent boilers with other boilers or appliances. Each boiler must have its own vent. Inspect finished vent and air piping thoroughly to ensure all are airtight and comply with instructions in this manual and applicable codes. Verify that all air openings are correctly sized, unobstructed, and free of airborne contaminants. Failure to provide a properly installed vent and air system will cause severe personal injury or death.

⚠ WARNING

Do not cover nonmetallic vent pipe with thermal insulation. Failure to comply can result in severe personal injury, death, or substantial property damage.

⚠ WARNING

Provide a vent manufacturer’s bird screen at each termination. Purchase bird screens from the vent or air piping supplier. Failure to comply can result in severe personal injury, death, or substantial property damage.

⚠ WARNING

Use sweep elbows for all vent and air piping. DO NOT use short-radius elbows for vent or air piping. Failure to comply can result in severe personal injury, death, or substantial property damage.

Venting Methods

There are two venting methods available. Follow the instructions on the following pages for the method used.

Method 1: Direct Exhaust

Combustion air is taken from the inside. Air piping is not connected to the air intake.

Combustion air must be supplied through openings into the boiler room. Follow the instructions in this manual and comply with all applicable codes. Combustion air must not be exposed to any of the contaminants listed in [Table 7, page 30](#). Ensure the air and boiler will not contain contaminated air.

Where the SVF boiler shares a space with other appliances, the combustion air openings must be sized to handle the combined requirements of all appliances in the space.

Method 2: Direct Vent

Combustion air is piped to the boiler from the outside. Follow the instructions in this manual and comply with all applicable codes. Ensure the air intake is not likely to draw in contaminated air. Do not terminate air piping in locations that can allow contamination of combustion air. Refer to [Table 7, page 30](#) for a list of contaminants and sources.

Combustion air can be piped individually for each boiler, or it can be manifolded as shown in [Figure 32, page 47](#). Combustion and ventilation openings may also be required in boiler room walls per instructions in this manual and applicable codes.

Vent and Air Piping

Use only the materials listed in this manual for vent and air pipe and fittings. Refer to [page 34](#) for information and hazards.

Boiler Categories

The SVF boilers are approved for Category II and Category IV ratings. The following pages of this manual will specify which category applies to the venting information given.

Category II: The boiler is setup with a negative pressure vent and is likely to condense in the vent. This category requires a direct exhaust venting method.

Category IV: The boiler is setup with a positive pressure vent and is likely to condense in the vent. This category can use either direct exhaust or direct vent methods.

Venting and Combustion Air - General, continued

Using a Chimney

⚠WARNING

A chimney must only be used as a chase for vent and air piping and must meet all requirements as listed below. Failure to comply can result in severe personal injury, death, or substantial property damage.

A masonry chimney can only be used as a pipe chase for vent and air pipes. No other appliance or fireplace can be connected to the chimney.

- The vent and air piping must be installed as instructed in this manual. All joints must be sealed.
- The chimney must be straight with no offsets. The vent and air piping materials must comply with this instruction manual.
- The chimney must be fitted with a sealed access opening through which the interior of the chimney can be inspected.
- The chimney and liner must be inspected at least once annually.

Combustion Air Contamination

Provide combustion air openings or air inlet piping as described in this manual. See Table 7 for products and areas that may cause contaminated combustion air.

Table 7 Corrosive contaminants and sources

Products to avoid
Spray cans containing chloro/fluorocarbons
Permanent wave solutions
Chlorinated waxes and cleaners
Chlorine-based swimming pool chemicals
Calcium chloride used for thawing
Sodium chloride used for water softening
Refrigerant leaks
Paint or varnish removers
Hydrochloric acid and muriatic acid
Cements and glues
Anti-static fabric softeners used in clothes dryers
Chlorine-type bleaches, detergents, and cleaning solvents
Adhesives used to fasten building products and other similar products
Excessive dust and dirt

Areas likely to have contaminants
Laundry and dry cleaning areas and establishments
Swimming pools
Metal fabrication plants
Beauty shops
Refrigeration repair shops
Photo processing plants
Auto body shops
Plastic manufacturing plants
Furniture refinishing areas and establishments
New building construction
Remodeling areas
Garages with workshops

Vent and Air Adapters

Vent connections are sized for DuraVent Fas-N-Seal®, DuraVent PolyPro®, PVC, and CPVC venting. Installers must provide the correct PVC/CPVC adapters where necessary. See Table 8 for a list of adapters and part numbers.

CPVC pipe must be used on the first 10 linear ft. of the exhaust of a boiler. PVC can only be used after 10 linear ft. of CPVC. All fittings within the first 10 ft. must be CPVC. See Figure 22 for more information.

⚠ WARNING

DO NOT use PVC on the first 10 ft. of boiler exhaust piping. Failure to comply can result in severe personal injury, death, or substantial property damage.

Flue Support Clamp

The flue support clamp may come unassembled from the factory and will need to be assembled before installing on to the boiler exhaust pipe. You should have a bag with the following components:

- QTY 3: Assembly Straps
- QTY 2: Clamps

Take one of the clamps and position all 3 assembly straps as shown in Figure 19. Ensure that the straps are facing the same direction and evenly spaced out around the circular clamp (about 120°) as shown below. Adjust the clamp so that it is roughly 7-9 inches in diameter.

Figure 19 Assembling flue support clamp

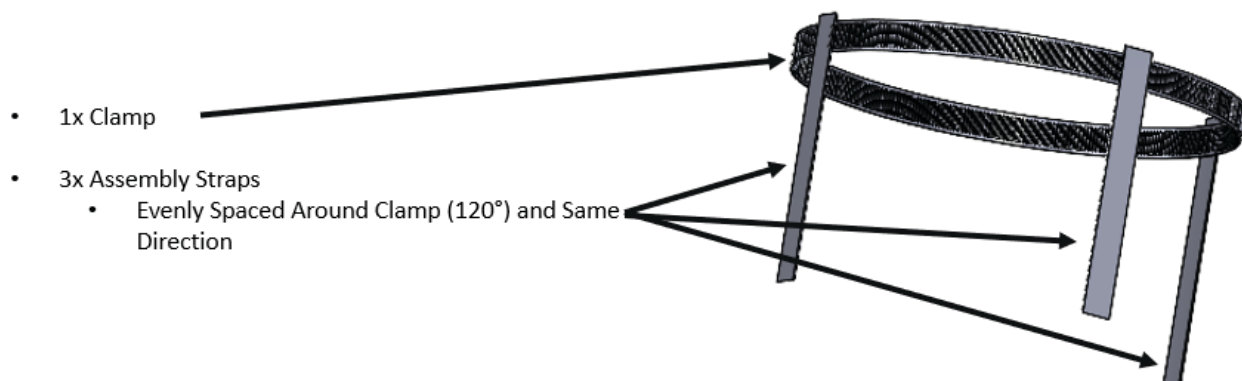

Take the 2nd clamp and feed it through the other end of the assembly straps. Adjust this clamp so it is roughly 7-9 inches in diameter to match the first clamp, see Figure 20 below for complete assembly.

Figure 20 Assembled flue support clamp



The flue support clamp is now ready to be used. Continue with the instructions on the next page to install the flue support clamp.

Venting and Combustion Air - General, continued

The flue support clamp must be installed to help secure the exhaust pipe to the boiler. The clamp is provided with the boiler. Reference Figure 21 for installation.

1. Secure the bottom part of the clamp to the vent connection adapter. Locate it just under the ridge and around the ribs.
2. Secure the top part of the clamp to the exhaust pipe.
3. Torque the hose clamps to 50 in-lbs (5.65 Nm).

Figure 21 Flue support clamp, installed



220178

Table 8 Vent and air adapter part numbers

SVF Boiler Models 725/850			
Supplier / Manufacturer	Description	Mechanical Locking Collar	Vent Adapter Part Number
M&G Simpson-DuraVent PolyPro®	6" polypropylene pipe	810004243 (PPS-PACL)	No adapter required
Centrotherm Eco Systems InnoFlue® Single-wall	6" polypropylene pipe	IADHC0606	ISAAL0606
M&G Simpson-DuraVent Fas-N-Seal®	6" AL29-4C SS	—	No adapter required
Heat Fab, Inc. Saf-T-Vent®	6" AL29-4C SS	—	9601PVC
Metal-Fab, Inc. Corr/Guard®	6" AL29-4C SS	—	6FCSPVCA
Z-Flex, Inc. Z-Vent®	6" AL29-4C SS	—	2SVSPVC06

Figure 22 PVC venting requirements

Exhaust ONLY after 10 linear ft., the pipe and fittings can then be transitioned from CPVC to PVC.

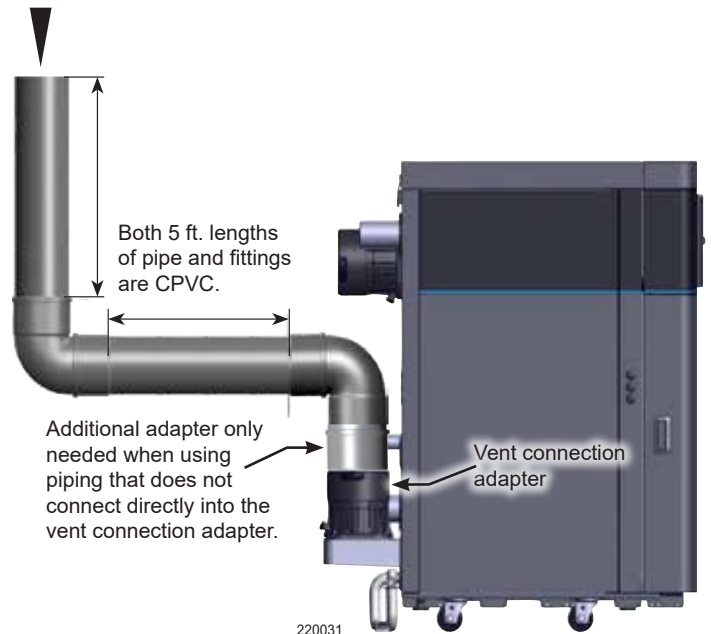

220031

Venting and Combustion Air Options

Existing Vent System

⚠ DANGER

DO NOT install the SVF boiler into a common vent with any other appliance. This will cause flue gas spillage or appliance malfunction, resulting in severe personal injury, death, or substantial property damage.

⚠ WARNING

Follow all venting and piping instructions. Failure to follow all instructions can cause flue gas spillage and carbon monoxide emissions, which can result in severe personal injury or death.

When replacing an existing boiler with an SVF boiler, do not use the existing common vent. The SVF boiler requires its own vent and air piping as specified in this manual. If using a Category II system setup, see additional venting requirements on pages [35-36](#).

Removal of the previous boiler may cause an issue for the appliances that remain on the old common vent as the vent may be too large. The following test is intended to check for proper operation of the appliances remaining on the old common vent system.

Existing Vent System Test Procedure

Perform this test when removing a boiler from the common venting system. The following steps shall be followed with each appliance remaining connected to the common venting system. Test each appliance separately while in operation. Ensure all other appliances connected to the common vent are not in operation.

1. Seal any unused openings in the common venting system before proceeding with the test.
2. Visually inspect the venting system for proper size and horizontal pitch. Ensure there is no blockage, restriction, leakage, corrosion, or other deficiency that could cause an unsafe condition.
3. Close all building doors and windows as practical. Close all doors between the location of the appliances connected to the common venting system and other spaces of the building.
4. Turn on the clothes dryer and any other appliance not connected to the common venting system. Turn on all exhaust fans, except for a summer exhaust fan, and operate at maximum speed. Exhaust fans include range hoods and bathroom fans. Close fireplace dampers.
5. Place the appliance being inspected into operation. Follow the lighting instructions. Adjust the thermostat so the appliance will operate continuously.
6. Test for spillage at the draft hood relief opening after five minutes of main burner operation. Use the flame of a match or candle, or smoke from a cigarette, cigar, or pipe.
7. After it has been determined that each appliance remaining connected to the common venting system properly vents when tested as outlined here, return doors, windows, exhaust fans, fireplace dampers, and any other gas-burning appliance to their previous conditions of use.

Correct any improper operation of the common venting system so the installation conforms with the National Fuel Gas Code – ANSI Z223.1/NFPA 54, latest edition. Adhere to the National Gas and Propane Installation Code – CAN/CSA B149.1 for Canada.

When resizing any portion of the common venting system, approach the minimum size as determined using the appropriate tables in part 11 of the National Fuel Gas Code – ANSI Z223.1/NFPA 54, and Natural Gas and Propane Installation Code – CAN/CSA B149.1.

Venting and Combustion Air Options, continued

Vent and Air Piping Materials

Use only the materials listed in Table 9 for vent and air piping. Ensure that all materials used meet local codes. See Table 8, page 32 for adapter part numbers.

Every PP vent and air piping joint must include a locking collar. See Table 8, page 32 for required lock collar part numbers. DO NOT use alternative locking collars.

All PVC and CPVC joints should be permanently joined using the suitable primer and cement for the vent material.

⚠WARNING

DO NOT use cellular core PVC (ASTM F891), cellular core CPVC, Radel® (polyphenylsulfone) pipe, or any other material not listed in Table 9. Failure to comply can result in severe personal injury, death, or substantial property damage.

⚠WARNING

Failure to supply locking collars and seal the joints could cause vent and air piping leakage, which can result in severe personal injury, death, or substantial property damage.

⚠WARNING

DO NOT mix piping from different pipe manufacturers unless using adapters specifically designed for that purpose by the manufacturer. Failure to comply can result in severe personal injury, death, or substantial property damage.

Table 9 Vent and air piping materials

Items	Material	Supplier / Manufacturer	United States	Canada
Vent or air pipe fittings	Polypropylene	M&G Simpson-DuraVent - PolyPro	Certified for Category II & IV and direct vent appliance venting	Plastic vent pipe must be certified to ULC S636 if required by local codes
		Centrotherm Eco Systems - InnoFlue Single-wall -Requires adapter by others-		
	AL29-4C stainless steel	M&G Simpson-DuraVent - Fas-N-Seal	Certified for Category II & IV and direct vent appliance venting	Certified for Category II & IV and direct vent appliance venting
		Heat Fab, Inc. - Saf-T Vent -Requires adapter by others-		
		Metal-Fab, Inc. - Corr/Guard -Requires adapter by others-		
		Z-Flex, Inc. - Z-Vent -Requires adapter by others-		
		PVC Schedule 40 See Vent and Air Adapters for additional requirements when using PVC on the exhaust.	ANSI/ASTM D1785	Plastic vent pipe must be certified to ULC S636 if required by local jurisdiction. Air pipe can be any of those listed at left if acceptable by local codes.
	PVC-DWV Schedule 40 See Vent and Air Adapters for additional requirements when using PVC on the exhaust.	ANSI/ASTM D2665		
	CPVC Schedule 40	ANSI/ASTM F441		
Primer and Cement	PVC	ANSI/ASTM D2564 (cement) ANSI/ASTM F656 (primer)	ULC S636 rated Primers and Cements	
	CPVC	ANSI/ASTM F493 (cement) Primer that is approved for CPVC.		
	CPVC to PVC transition	Use only Primer and Cement suitable for joining CPVC and PVC pipe.		



Category II Requirements

In addition to the SVF boilers Category IV rating (positive pressure, likely to condense), SVF boilers are also approved for Category II (negative pressure, likely to condense).

The vent system for a Category II SVF boiler is considered a designed and engineered vent system. This system should be designed by a professional while using accepted engineering practices in accordance to local authority having jurisdiction. The Category II venting option requirements are as follows.

- Vertical vent termination only.
- Must not be installed into an existing common vent system with other appliances.
- Combustion air from the boiler room. See Direct Exhaust Combustion Air opening requirements in [Figure 25, page 39](#).
- The vent shall consist of a 3.5 ft. length piece of 6" diameter straight pipe directly after the vent or air adapter, and before any diameter or direction changes in the vent. After at least 3.5 ft. of piping, installer can use a bushing up to an 8" diameter. See [Figure 23](#) for an example. See [Table 10](#) for boiler-specific vent data.
- The vent system should be designed so that the pressure in the vertical vent pipe immediately following the boiler is between the ranges provided in [Table 10](#) during all operating conditions (e.g., High fire, Low Fire).
- Flue gas temperature should not exceed 210°F. The boiler will start to reduce the firing rate at a flue temperature of 200°F, and it will shut down once it exceeds 210°F. The flue gas temperature standard is within 20°F and 30°F of the return water temperature of the boiler. If there is the potential for a wide variation in return water temperatures, the lowest possible temperature should be used for any calculations.
- The Stack/Vent Flow Rate for each individual boiler model is listed in [Table 10](#). This flow rate is based on the unit running at 9% CO₂ and the maximum flue gas temperature of 200°F. The values can vary depending on the location of the installation and operating conditions.

Figure 23 Category II venting



Table 10 Rating and vent data

Boiler Model	Input	Stack/ Vent flow rate	Negative pressure maintained at vent connection of the boiler	Connection/ Minimum vent diameter required for Category II*
	Btuh	Scfm	Inches W.C.	
SVF 725	725,000	150	-0.001 to -0.100	8"
SVF 850	850,000	175	-0.001 to -0.100	8"

*The SVF boiler vent or air connection is sized for 6" DuraVent Fas-N-Seal, DuraVent PolyPro, PVC, and CPVC venting. Installer must provide the correct adapters or reducers needed to connect to other approved vent manufacturer's products. See [Table 8, page 32](#) for a list of adapters.

- A carbon monoxide detector is required in the boiler room for SVF boilers installed in a Category II configuration. The carbon monoxide detector must be wired in the same electrical circuit as the boiler. Check your local codes for any additional requirements of carbon monoxide detectors.

Venting and Combustion Air Options, continued

Category II Requirements, continued

⚠ WARNING

Install a Category II boiler system per all instructions in this manual. Improper Installation of a Category II vent system that results in positive pressure in the vent system can cause flue gas spillage and carbon monoxide, which can result in severe personal injury or death.

In applications where the venting system cannot maintain the required negative pressure on the boiler outlet via natural draft, WM Technologies recommends the use of a variable speed chimney fan or power venter to ensure that the appropriate negative pressure range is kept for Category II venting. Due to the higher efficiency of the SVF boiler, the exhaust gas temperatures are lower, resulting in less draft when using a chimney fan or power venter.

A flow proving switch should also be wired into the closure switch on the terminal block P11 of the boiler. The use of this device should be considered in any engineered vent system in accordance to local authority having jurisdiction.

WM Technologies recommends the use of a double acting barometric damper or modulating damper to ensure the appropriate negative pressure range is kept for Category II venting. The use of this device should be considered in any engineered vent system in accordance to local authority having jurisdiction.

When using a damper of any kind, it is recommended to use a thermal spill switch to detect any exhaust flow into the boiler room. Verify the temperature range on the thermal spill switch is adequate for the flue gas temperature from the SVF boiler. The use and set-point of this shall be determined by the system engineer in accordance to local authority having jurisdiction.

Code Compliance:

Venting and combustion air piping installations must provide provisions for combustion and ventilation air in accordance with the section, "Venting of Equipment" of the National Fuel Gas Code – ANSI Z223.1/NFPA 54, latest edition, section "Venting Systems and Air Supply for Appliances" of the Natural Gas and Propane Installation Code – CAN/CSA B149.1, or applicable provisions of the local building codes.

⚠ WARNING

Follow all applicable national and local codes for installations. Failure to comply with the codes can result in severe personal injury, death, or substantial property damage.

Vent and Air Terminations for Category IV

The figure below lists the acceptable vent and air pipe terminations for Category IV as described in this manual.

The SVF boiler vent or air connection is sized for 6" DuraVent Fas-N-Seal, DuraVent PolyPro, PVC, and CPVC. The installer must provide the correct adapters/reducers needed to connect to other approved vent manufacturer's products.

The air inlet adapter is installed on the back of the boiler as shown in [Figure 73, page 113](#).

Figure 24 SVF boiler Category IV venting and air piping - options and piping limits

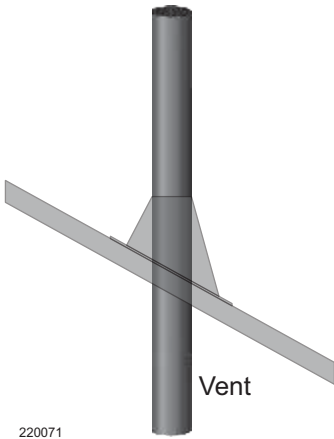
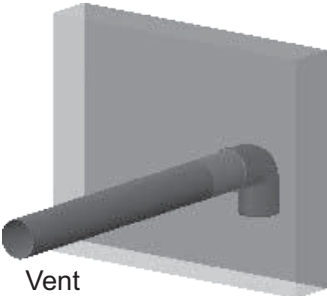
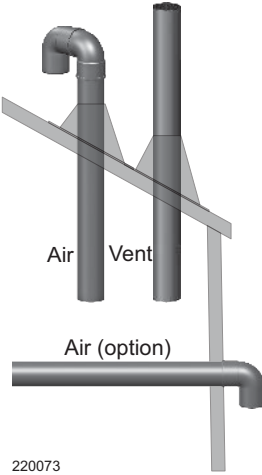
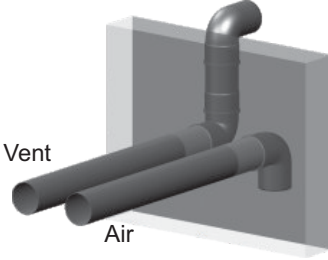
Use only the pipe materials listed in Table 9, page 34			
The information below is for SVF boiler models 725/850 with a 6" vent and 4" or 6" air piping			
Vertical Direct Exhaust	Sidewall Direct Exhaust	Vertical Direct Vent (vertical or sidewall air)	Sidewall Direct Vent (vent and air out sidewall)
 <p>220071</p>	 <p>220072</p>	 <p>220073</p>	 <p>220074</p>
See page 40	See page 42	See page 48	See page 52
Thickness of wall or roof vent penetration (all): Max: 18" Min: 0"			
Length, equivalent feet (all): Max: 100 ft. Min: 10 ft. (see information below)			
<p>Note: For Category IV installations, ensure the flue venting system is designed to maintain a slightly positive exhaust pressure which MUST BE in the following ranges:</p> <ul style="list-style-type: none"> +0.01" W.C. and +0.7" W.C.(Direct Vent / Sealed Combustion) +0.01" W.C. and +0.7" W.C.(Exhaust Only) <p>Note: Total vent combustion pressure not to exceed 0.7" W.C.</p>			
<p>NOTICE</p> <p>If the total number of elbows used in the vent and air piping and terminations is more than two elbows in the vent and one elbow in the air piping, reduce the maximum lengths above by the following lengths for each additional elbow (whether 45° or 90°). Boilers will derate as vent and air pipe length increases. See Table 21, page 122 for derate per piping length.</p> <p>PP & SS - 6" vent and 4" or 6" air piping: See the manufacturer's recommendations for equivalent vent length per elbow.</p> <p>PVC - 6" vent and 4" or 6" air piping: Reduce the maximum allowable length by 7 ft. for each additional elbow used.</p>			
<p>NOTICE</p> <p>If the pipe manufacturer's equivalent lengths for elbows are longer than the values listed above, use the manufacturer's value for length reduction per elbow.</p>			

DIRECT EXHAUST - Room Air Openings (Cat. II and IV)

Combustion Air Provision

NOTICE

A bird screen must be added to the inlet adapter to prevent large debris from entering the boiler cabinet.

The SVF commercial boiler can use inside air if no contaminants are present in the boiler space. If contaminants are likely to be present, install the boiler as a direct vent appliance. Use the appropriate vent instructions in this manual.

The boiler room must be fitted with combustion air openings large enough to provide air for all appliances in the room. Use the following information to size the openings. Ensure the installation complies with all applicable codes and standards.

Sizing Combustion Air Openings

Air openings provide ventilation to prevent overheating of the boiler controls and boiler space. Air is also needed for other appliances located in the same space. Use the information in [Figure 25, page 39](#) for air openings.

WARNING

Air openings must be sized to handle all appliances and air movers, such as exhaust fans, using the air supply. Failure to comply can result in severe personal injury, death, or substantial property damage.

The sizing given in [Figure 25, page 39](#) is based on the National Fuel Gas Code – ANSI Z223.1/ NFPA 54, latest edition. The sizing allows adequate air openings for gravity-vented gas appliances (Category I), in addition to the needs for the SVF boiler, provided the boiler room is not subjected to negative pressure due to exhaust fans or other mechanical ventilation devices.

The SVF commercial boiler is rated Category IV and has varying requirements for combustion and ventilation air, reflected by the special sizing instructions given in this manual. Refer to the National Fuel Gas Code for dealing with other conditions.

Free area and louvers

The free area of openings means the area after reduction for any installed louvers or grilles. Be sure to consider this reduction when sizing the air opening.

Special Considerations

Tight construction: The National Fuel Gas Code – ANSI Z223.1/NFPA 54, latest edition, defines unusually tight construction where all of the following is true:

1. Walls and ceilings exposed to the outside atmosphere have a continuous water vapor retarder with a rating of 1 perm or less with openings fitted with gaskets.
2. Weather-stripping has been added on windows and doors that are capable of being opened.
3. Caulking or sealants are applied to areas such as joints around windows and door frames, between sole plates and floors, between wall-ceiling joints, between wall panels, at penetrations for plumbing, electrical, and gas lines, and in other openings.

For buildings with such construction, provide air openings into the building from outside. Size the openings per the appropriate condition in [Figure 25, page 39](#) if appliances are to use inside air for combustion and ventilation.

Exhaust fans and movers: The appliance space must never be under a negative pressure unless all appliances are installed as direct vent. Always provide air openings sized to the dimensions required for the firing rate of all appliances, with the ability to handle the air movement rate of the exhaust fans or air movers using air from the building or space.

The damper/louver control can also provide 120V to operate a damper, and can provide input for a closure switch to allow the damper to prove it is in the open position.

Figure 25 Minimum combustion air openings for direct exhaust applications

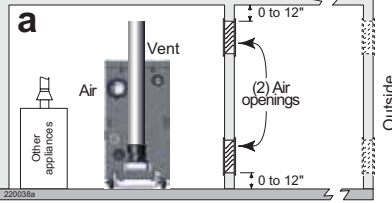
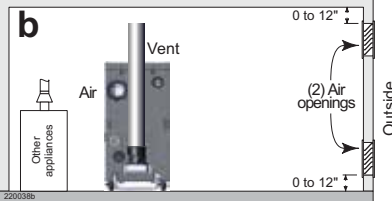
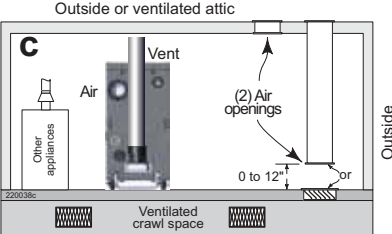
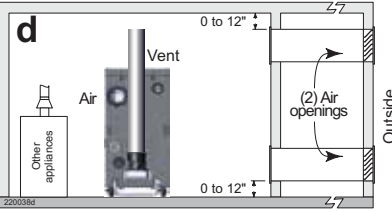
<p>Air openings The required air opening sizes below are FREE AREA, after reduction for louver obstruction. See the important below for large spaces.</p>	<p>SVF boiler WITH other appliances in the same room</p>	<p>SVF boiler WITHOUT other appliances in the same room</p>
	<p>Two openings, each at least: 1 square inch per 1,000 Btuh of all appliances in the room, but not less than 100 in².</p>	<p>Two openings, each at least: 1 square inch per 1,000 Btuh of all appliances in the room, but not less than 100 in².</p>
	<p>Two openings, each at least: 1 square inch per 2,000 Btuh of all appliances in the room -OR- One opening* at least: 1 square inch per 3,000 Btuh of all appliances in the room</p>	<p>Two openings, each at least: 1 square inch per 2,000 Btuh of all appliances in the room -OR- One opening* at least: 1 square inch per 3,000 Btuh of all appliances in the room</p>
	<p>Two openings, each at least: 1 square inch per 4,000 Btuh of all appliances in the room -OR- One opening* at least: 1 square inch per 3,000 Btuh of all appliances in the room</p>	<p>Two openings, each at least: 1 square inch per 4,000 Btuh of all appliances in the room -OR- One opening* at least: 1 square inch per 3,000 Btuh of all appliances in the room</p>
	<p>Two openings, each at least: 1 square inch per 2,000 Btuh of all appliances in the room -OR- One opening* at least: 1 square inch per 3,000 Btuh of all appliances in the room</p>	<p>Two openings, each at least: 1 square inch per 2,000 Btuh of all appliances in the room -OR- One opening* at least: 1 square inch per 3,000 Btuh of all appliances in the room</p>
<p>* Requirements for using the single air opening option</p>	<p>A single combustion air opening can be used for cases b, c, or d above, sized as listed, provided that the following are met:</p> <ul style="list-style-type: none"> • The single opening must communicate directly to open air outside of the building or to a space that communicates directly to the outside of the building. • The top of the opening must be within 12" of the ceiling. • The free area of the opening must be at least equal to the sum of the areas of all equipment vent connectors in the space. 	
<p>IMPORTANT A special exception exists for large spaces. See the information to the right.</p>	<p>No combustion air openings are needed when the boiler and other appliances are installed in a space with a volume no less than 50 cubic ft. per 1,000 Btuh of all appliances in the space. The building must NOT be of tight construction.</p> <p>Calculation: Take the total inputs of all appliances in MBH (1,000s Btuh) and multiply by 50. The space volume must be equal to or greater than the total of this calculation. [Total appliances input in MBH x 50] ≥ space volume</p> <p>Example: For a total input of 1500 MBH (1,500,000 Btuh), the minimum space volume necessary would be 1500 x 50 = 75,000 cubic ft.</p>	

DIRECT EXHAUST - Vertical Termination (Cat. II and IV)

Vertical Termination Location

The vent termination must be installed as shown in Figure 26. The termination placement must comply with clearances and limitations shown in [Figure 27](#), page 42.

1. Install the termination in a location where damage from foreign objects and buildup of leaves or sediment is unlikely.
2. Ensure proper clearance above grade or snow line. Keep vents and air area clear of accumulating snow.
3. Install the boiler in a location that allows proper routing of all vent piping from the boiler vent connection to the selected vertical location.

WARNING

Locate the termination such that the total vent piping from the boiler to the termination will not exceed the maximum length given in [Figure 24](#), page 37 for Category IV venting. Failure to comply can result in severe personal injury, death, or substantial property damage.

Multiple Vent Terminations

When terminating multiple SVF boilers, terminate each vent connection as described in this manual.

For U.S. installations, place wall penetrations to obtain minimum clearances shown in Figure 26.

For Canadian installations, provide clearances required by Natural Gas and Propane Installation Code – CAN/CSA B149.1. Use a ULC S636 compliant vent kit.

IMPORTANT

Read and follow all instructions in this manual. Do not proceed with vent installation until you have read [page 29](#) through [page 42](#). Comply with all vent system manufacturer's instructions.

Figure 26 Vertical direct exhaust termination

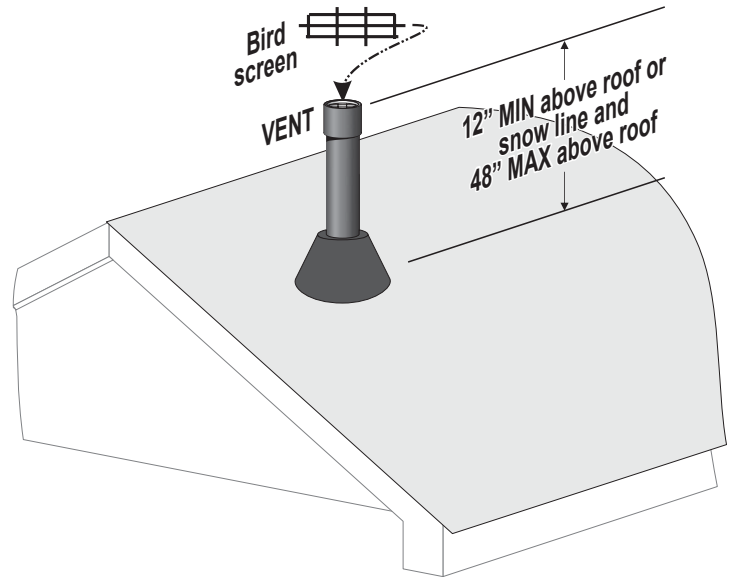

Vent Piping Installation

⚠WARNING

Use only the vent materials and kits listed in [Table 9, page 34](#). Failure to comply can result in severe personal injury, death, or substantial property damage.

⚠WARNING

Every joint on polypropylene vent piping must include a locking collar. Failure to supply locking collars could cause vent or air piping leakage, which can result in severe personal injury or death.

NOTICE

Use sweep elbows for all vent piping when possible. Short-radius elbows cause higher pressure loss, resulting in less allowable vent and air piping length. See [Figure 24, page 37](#) for maximum length reductions required for fittings.

1. Install a vent adapter if needed. Follow instructions from the vent manufacturer.
2. Install a reducer from a vent manufacturer if needed to adapt to the vent size.
3. Slope vent piping toward the boiler a minimum of 1/4" per foot in horizontal runs or larger per vent pipe manufacturer's instructions.
4. Support piping independently of the boiler. Install pipe supports every 5 ft. on both the horizontal and vertical runs. Install a hanger support within 6" of any upturn in the piping.

Vent Termination Installation

1. Vent pipe penetration:
 - a. Cut a hole for the vent pipe.
 - b. For combustible construction, size the vent pipe hole at least 3/8" larger than the vent pipe diameter. Size larger if specified by the vent manufacturer.
 - c. For noncombustible construction, size the opening per vent manufacturer's instructions.
 - d. Insert a corrosion-resistant metal thimble in the vent pipe hole.
 - e. Follow all local codes for isolation of the vent pipe when passing through floors, ceilings, and roofs.
2. Provide flashing and sealing boots sized for the vent pipe.
3. Use a coupling or open-end pipe termination. Follow the guidelines from the vent manufacturer for vertical terminations.
4. Install a bird screen from the vent manufacturer in the open end of the termination.
5. Maintain the required dimensions of the finished termination piping as shown in [Figure 26, page 40](#). Follow the vent or air pipe manufacturer's instructions for proper protection and support of the piping.

⚠WARNING

Do not exceed the maximum length of the outside vent piping shown in [Figure 26, page 40](#). Excessive length exposed to the outside can cause freezing of condensate in the vent pipe, or vent and air piping failure, which can result in severe personal injury, death, or substantial property damage.

DIRECT EXHAUST - Sidewall Termination (Category IV)

Sidewall Termination Location

⚠ WARNING

Follow all location requirements in this section. Failure to comply can result in severe personal injury, death, or substantial property damage.

- The minimum distance from adjacent public walkways, adjacent buildings, windows that can open, and building openings shall not be less than the values specified in the National Fuel Gas Code – ANSI Z223.1/NFPA 54, latest edition, or the National Gas and Propane Installation code – CAN/CSA B149.1.

- Vent and air terminations must be installed at least 12" (0.31m) above grade and snow line.
- Consideration should be given to avoid possible damage caused by vent plumes and condensate when choosing a venting configuration and location.
- Maintain a minimum clearance of 4 ft. (1.22 m) horizontally from electrical meters, gas meters, regulators, and relief equipment. Do not install above or below meters, regulators, or relief equipment.

Figure 27 Direct exhaust installation requirements for termination location

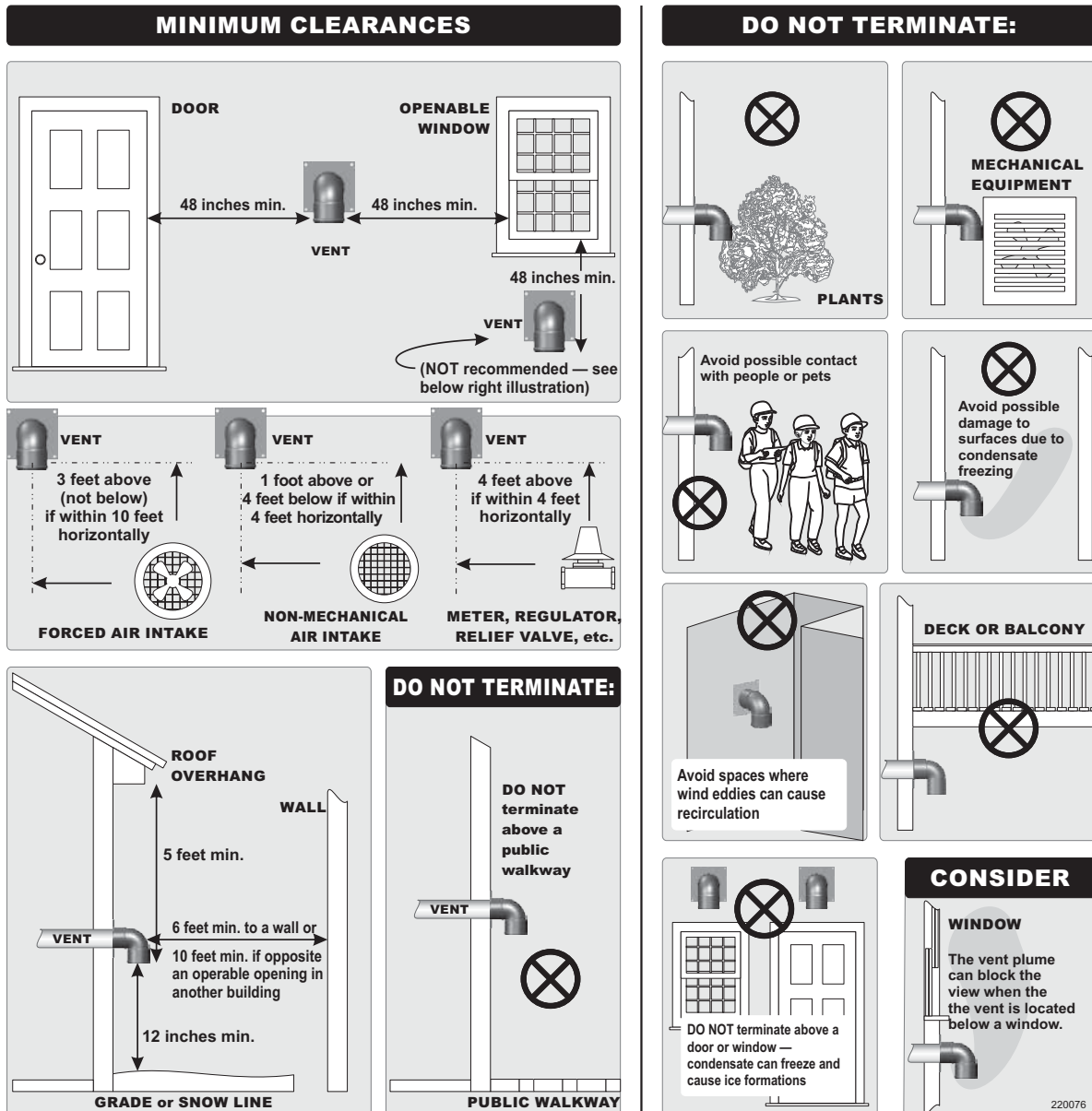

Determine Termination Location

The vent termination must be installed as shown in Figure 28 and Figure 30, page 44. The termination placement must comply with clearances and limitations shown in Figure 27, page 42.

1. Install the termination in a location where damage from foreign objects and buildup of leaves or sediment is unlikely.
2. Ensure proper clearance above grade or snow line. Keep vents and air area clear of accumulating snow.
3. Install the boiler in a location that allows proper routing of all vent piping from the boiler vent connection to the selected sidewall location.

⚠️WARNING

Locate the termination such that the total vent piping from the boiler to the termination will not exceed the maximum length given in Figure 24, page 37 for Category IV venting. Failure to comply can result in severe personal injury, death, or substantial property damage.

IMPORTANT

Read and follow all instructions in this manual. Do not proceed with vent installation until you have read page 29 through page 42. Comply with all vent system manufacturer's instructions.

Multiple Vent Terminations

When terminating multiple SVF boilers, terminate each vent connection as described in this manual. See Figure 29, page 44 for a typical layout.

For U.S. installations, place wall penetrations to obtain minimum clearances shown in Figure 28.

For Canadian installations, provide clearances required by Natural Gas and Propane Installation Code – CAN/CSA B149.1. Use a ULC S636-compliant vent kit.

Figure 28 Sidewall direct exhaust termination

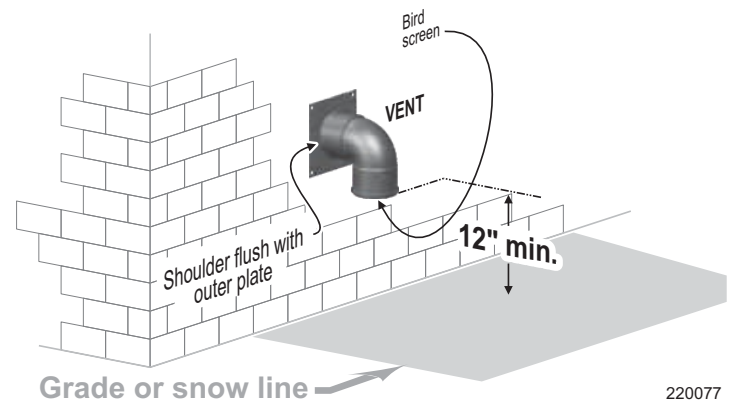

220077

Vent Piping Installation

⚠️WARNING

Use only the vent materials and kits listed in Table 9, page 34. Failure to comply can result in severe personal injury, death, or substantial property damage.

⚠️WARNING

Every joint on polypropylene vent piping must include a locking collar. Failure to supply locking collars could cause vent or air piping leakage, which can result in severe personal injury or death.

⚠️WARNING

Use sweep elbows for all vent and air piping. DO NOT use short-radius elbows for vent or air piping. Failure to comply can result in severe personal injury, death, or substantial property damage.

1. Install a vent adapter if needed. Follow instructions from the vent manufacturer.
2. Install a reducer from a vent manufacturer if needed to adapt to the vent size.
3. Slope vent piping toward the boiler a minimum of 1/4" per foot in horizontal runs or larger per vent pipe manufacturer's instructions.
4. Support piping independently of the boiler. Install pipe supports every 5 ft. on both the horizontal and vertical runs. Install a hanger support within 6" of any upturn in the piping.

DIRECT EXHAUST - Sidewall Termination, continued (Category IV)

Vent Termination Installation

Maintain the required dimensions of the finished termination piping as shown in Figure 27, page 42.

1. Vent pipe penetration
 - a. Cut a hole for the vent pipe
 - b. For combustible construction, size the vent pipe hole at least 3/8" larger than the vent pipe diameter. Size larger if specified by the vent manufacturer.
 - c. For noncombustible construction, size the opening per vent manufacturer's instructions.
 - d. Insert a corrosion-resistant metal thimble in the vent pipe hole as shown in Figure 30.
 - e. Follow all local codes for isolation of vent pipe when passing through floors, ceilings, and roofs.
2. Provide and install corrosion-resistant metal stop plates. See Figure 30, item 3.
 - a. The hole size in the stop plates must be just larger than the vent pipe diameter.
 - b. Obtain stop plates only from the vent pipe manufacturer.
3. Insert the last length of vent pipe from the outside. The shoulder of the vent pipe female end must rest against the outer stop plate as shown. The plate must prevent the vent from being pushed inward.
4. Insert the termination elbow into the vent pipe end.
5. Install a bird screen from the vent manufacturer in the open end of the termination.
6. Seal exterior openings thoroughly with exterior caulk.
7. See Figure 29 for multiple boiler terminations.

⚠ WARNING

Do not exceed the maximum length of the outside vent piping shown in Figure 26, page 40. Excessive length exposed to the outside can cause freezing of condensate in the vent pipe, or vent and air piping failure. Follow vent or air pipe manufacturer's instructions for proper protection and support of the piping. Failure to comply can result in severe personal injury, death, or substantial property damage.

Figure 29 Multiple boiler direct exhaust sidewall terminations

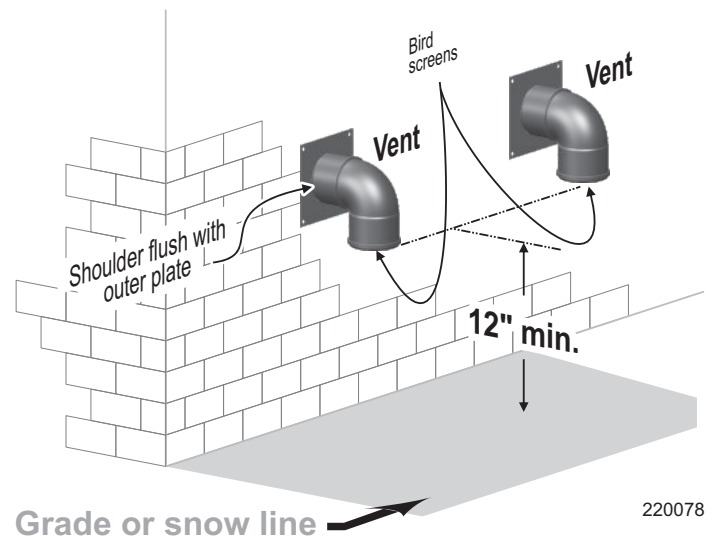
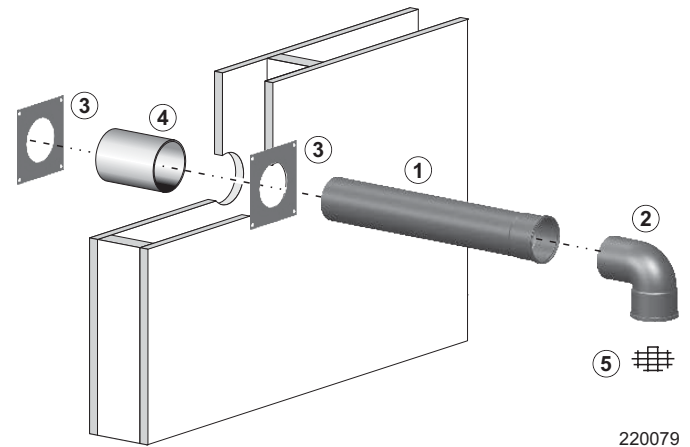

Figure 30 Sidewall termination assembly for direct exhaust installations



- | | |
|--|--|
| 1. Insert vent piping from the outside until the female end shoulder rests against the outside stop plate. | 3. Vent manufacturer's sidewall stop plates (hole must be just larger than the vent diameter). |
| 2. Use a down-turned 90-degree elbow for termination. | 4. Corrosion-resistant thimble, by installer |
| | 5. Bird screen, by installer |

DIRECT VENT - Room Air Openings (Category IV)

Combustion and Ventilation Air Provision

For direct vent installations, combustion air must be ducted directly from outside to the boiler air intake fitting. Sidewall or vertical options are available. The boiler room will still require air openings for ventilation and for combustion air for other appliances.

Sizing Air Openings

Air openings provide ventilation to prevent overheating of the boiler controls and boiler space. Use the information in [Figure 31, page 46](#) for air openings.

⚠ WARNING

Air openings must be sized to handle all appliances and air movers, such as exhaust fans, using the air supply. Failure to comply can result in severe personal injury, death, or substantial property damage.

The sizing given in [Figure 31, page 46](#) is based on the National Fuel Gas Code – ANSI Z223.1/NFPA 54, latest edition. The sizing allows adequate air openings for gravity-vented gas appliances (Category I) when located in the same space as the SVF boiler.

When outside air is ducted as directed in this manual, the SVF commercial boiler is rated as direct vent (pressurized vent), and has varying requirements for combustion and ventilation air. The air openings in [Figure 31, page 46](#) will allow adequate ventilation and combustion air, provided the boiler room is not subjected to negative pressure due to exhaust fans or other mechanical ventilation devices. Refer to the National Fuel Gas Code – ANSI Z223.1/NFPA 54, latest edition, for dealing with other conditions.

Free area and louvers: The free area of openings means the area after reduction for any installed louvers or grilles. Be sure to consider this reduction when sizing the air opening.

Special Considerations

Tight construction

ANSI Z223.1/NFPA 54 defines unusually tight construction where all of the following is true:

1. Walls and ceilings exposed to the outside atmosphere have a continuous water vapor retarder with a rating of 1 perm or less with openings fitted with gaskets.
2. Weather-stripping has been added on windows and doors that are capable of being opened.
3. Caulking or sealants are applied to areas such as joints around windows and door frames, between sole plates and floors, between wall-ceiling joints, between wall panels, at penetrations for plumbing, electrical, and gas lines, and in other openings.

For buildings with such construction, provide air openings into the building from outside. Size the openings per [Figure 31, page 46](#) if appliances are to use inside air for combustion and ventilation.

Exhaust fans and movers

The appliance space must never be under a negative pressure unless all appliances are installed as direct vent. Always provide air openings sized to the dimensions required for the firing rate of all appliances, with the ability to handle the air movement rate of the exhaust fans or air movers using air from the building or space.

DIRECT VENT - Room Air Openings, continued (Category IV)

Figure 31 Minimum combustion air openings for direct vent applications

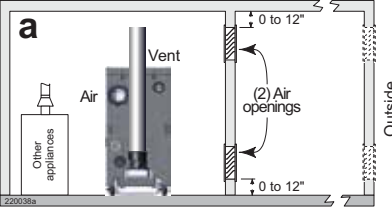
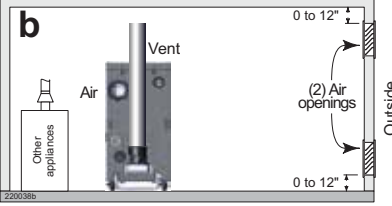
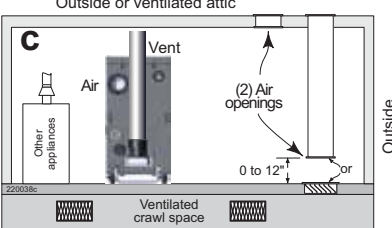
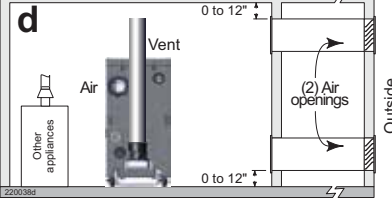
<p>Air openings The required air opening sizes below are FREE AREA, after reduction for louver obstruction. See the important below for large spaces.</p>	<p>SVF boiler WITH other appliances in the same room</p>	<p>SVF boiler WITHOUT other appliances in the same room</p>
	<p>Two openings, each at least: 1 square inch per 1,000 Btuh of all appliances in the room, but not less than 100 in².</p>	
	<p>Two openings, each at least: 1 square inch per 2,000 Btuh of all appliances in the room -OR- One opening* at least: 1 square inch per 3,000 Btuh of all appliances in the room</p>	<p>No openings are required if the boiler installation provides at least the recommended service clearances shown on page 11</p>
	<p>Two openings, each at least: 1 square inch per 2,000 Btuh of all appliances in the room -OR- One opening* at least: 1 square inch per 3,000 Btuh of all appliances in the room</p>	<p>If the space is smaller, provide one opening to a room with at least 1 square inch per 3,000 Btuh of boiler input</p>
	<p>Two openings, each at least: 1 square inch per 2,000 Btuh of all appliances in the room -OR- One opening* at least: 1 square inch per 3,000 Btuh of all appliances in the room</p>	
<p>* Requirements for using the single air opening option</p>	<p>A single combustion air opening can be used for cases b, c, or d above, sized as listed, provided that the following are met:</p> <ul style="list-style-type: none"> • The single opening must communicate directly to open air outside of the building or to a space that communicates directly to the outside of the building. • The top of the opening must be within 12" of the ceiling. • The free area of the opening must be at least equal to the sum of the areas of all equipment vent connectors in the space. 	
<p>IMPORTANT</p> <p>A special exception exists for large spaces. See the information to the right.</p>	<p>No combustion air openings are needed when the boiler and other appliances are installed in a space with a volume no less than 50 cubic ft. per 1,000 Btuh of all appliances in the space. The building must NOT be of tight construction.</p> <p>Calculation: Take the total inputs of all appliances in MBH (1,000s Btuh) and multiply by 50. The space volume must be equal to or greater than the total of this calculation. [Total appliances input in MBH x 50] ≥ space volume</p> <p>Example: For a total input of 1500 MBH (1,500,000 Btuh), the minimum space volume necessary would be 1500 x 50 = 75,000 cubic ft.</p>	

Combustion Air Manifold Option

Multiple SVF boilers can use a common combustion air manifold. Size the duct to provide at least one square inch per 2,000 Btuh total input of connected boilers. Provide a minimum clearance to adjacent vents and grade or snow line as shown in Figure 32.

Provide minimum free area in duct, adjusted for louver restriction, of one square inch per 2,000 Btuh total boiler input. Calculate by dividing the total MBH by two. Example: For an MBS system with total input of 3,000 MBH (3,000,000 Btuh), minimum free area for a combined air duct would be $3,000 \div 2 = 1500$ square inches.

WARNING

DO NOT use combined Category IV vent piping; only air piping can be combined. Flue gas leakage and boiler component damage can occur if vent piping is combined. Failure to comply can result in severe personal injury, death, or substantial property damage.

Figure 32 Manifolded combustion air option

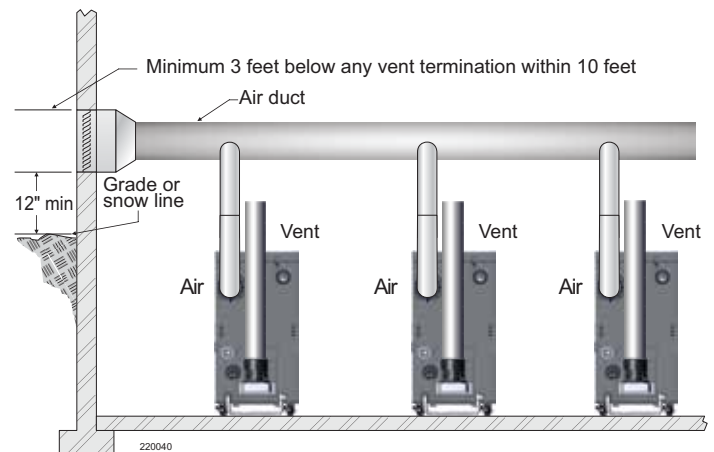

DIRECT VENT - Vertical Termination (Category IV)

Vertical Termination Location

The vent and air terminations must be installed as shown in Figure 33. The air termination can be through either the roof or a sidewall as shown. The termination placement must comply with clearances and limitations shown on the following pages.

1. Install the termination in a location where damage from foreign objects and buildup of leaves or sediment is unlikely.
2. Ensure proper clearance above grade or snow line. Keep vents and air area clear of accumulating snow.
3. Install the boiler in a location that allows proper routing of all vent piping from the boiler vent connection to the selected sidewall location.

⚠ WARNING

Locate the termination such that the total vent piping from the boiler to the termination will not exceed the maximum length given in [Figure 24, page 37](#) for Category IV venting. Failure to comply can result in severe personal injury, death, or substantial property damage.

Multiple Vent Terminations

When terminating multiple SVF boilers, terminate each vent connection as described in this manual. See [Figure 40, page 53](#) for typical sidewall air termination layouts.

For U.S. installations, place roof penetrations to obtain a minimum clearance of 12" between edge of air intake elbow and adjacent vent pipe of another boiler as shown in [Figure 35, page 49](#).

For Canadian installations, provide clearances required by Natural Gas and Propane Installation Code – CAN/CSA B149.1. Use a ULC S636-compliant vent kit.

IMPORTANT

Read and follow all instructions in this manual. Do not proceed with vent installation until you have read pages [29-36](#), [45-46](#), & [52](#). Comply with all vent system manufacturer's instructions.

Figure 33 Vertical direct vent terminations

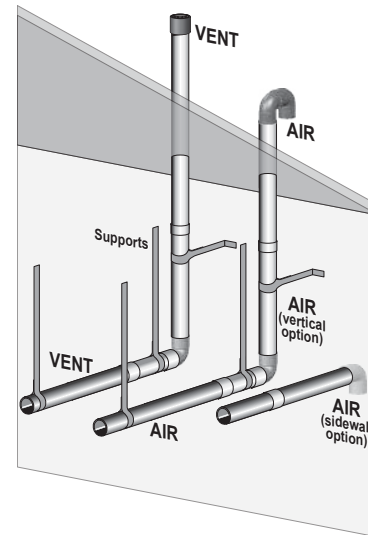

Vent Piping Installation

⚠ WARNING

Use only the vent materials and kits listed in [Table 9, page 34](#). Failure to comply can result in severe personal injury, death, or substantial property damage.

⚠ WARNING

Every joint on polypropylene vent piping must include a locking collar. Failure to supply locking collars could cause vent or air piping leakage, resulting in severe personal injury or death.

⚠ WARNING

Use sweep elbows for all vent and air piping. DO NOT use short-radius elbows for vent or air piping. Failure to comply can result in severe personal injury, death, or substantial property damage.

1. Install a vent adapter if needed. Follow instructions from the vent manufacturer.
2. Install a reducer from a vent manufacturer if needed to adapt to the vent size.
3. Slope vent piping toward the boiler a minimum of 1/4" per foot in horizontal runs or larger per vent pipe manufacturer's instructions.
4. Support piping independently of the boiler. Install pipe supports every 5 ft. on both the horizontal and vertical runs. Install a hanger support within 6" of any upturn in the piping.

Vent and Air Termination Installation

Maintain the required dimensions of the finished termination piping as shown in the figures in this section.

WARNING

Terminate all vent pipes the same height and all air pipes at the same height. Failure to comply can result in severe personal injury, death, or substantial property damage.

1. Air pipe penetration:
 - a. Cut a hole for the air pipe, sized per the manufacturer's instructions.
2. Vent pipe penetration
 - a. Cut a hole for the vent pipe
 - b. For combustible construction, size the vent pipe hole at least 3/8" larger than the vent pipe diameter. Size larger if specified by the vent manufacturer.
 - c. For noncombustible construction, size the opening per vent manufacturer's instructions.
 - d. Insert a corrosion-resistant metal thimble in the vent pipe hole.
 - e. Follow all local codes for isolation of vent pipe when passing through floors, ceilings, and roofs.
3. Vertical vent termination, vertical air termination:
 - a. Provide flashing and sealing boots sized for the vent pipe.
 - b. Use a coupling or open-end pipe termination. Follow the guidelines from the vent manufacturer for vertical terminations.
 - c. Install a bird screen from the vent or air manufacturer in the open end of the terminations.

Figure 34 Vertical vent & air terminations

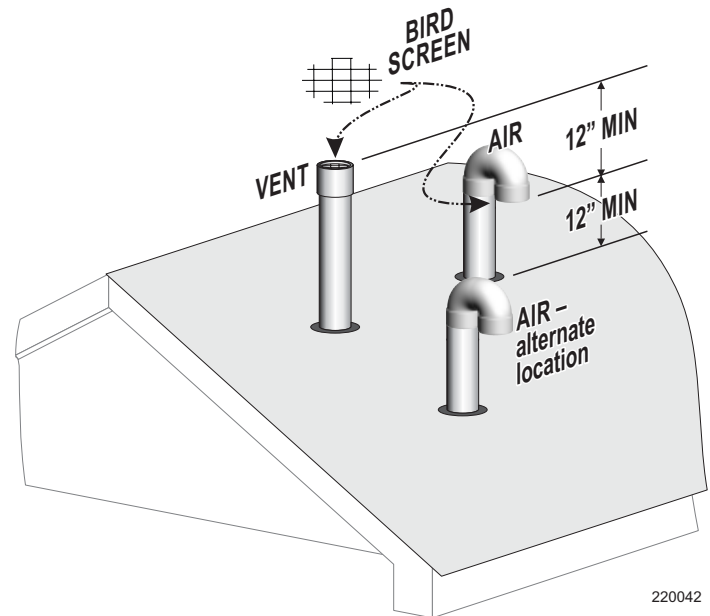
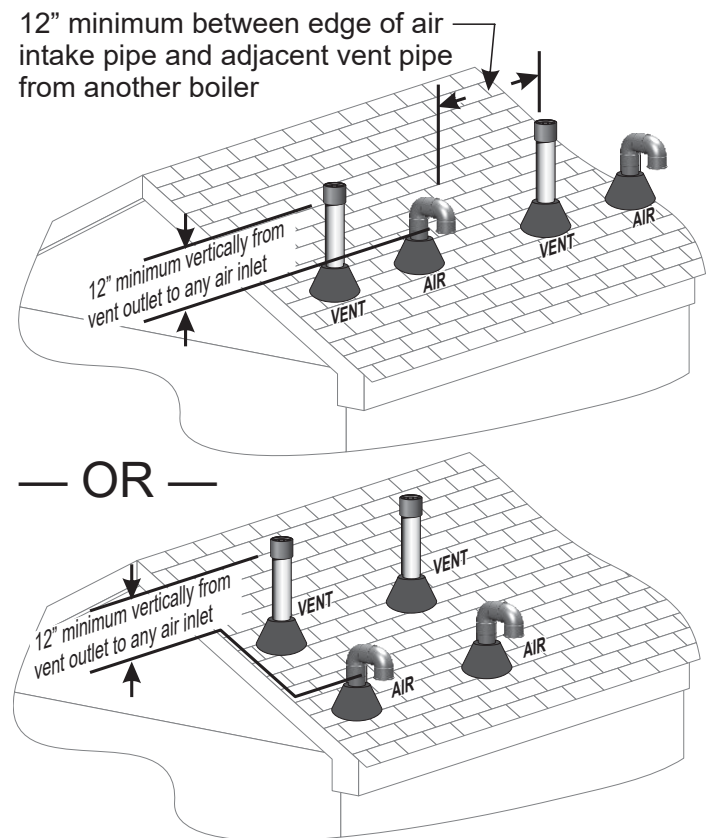

Figure 35 Vertical vent & air piping - termination location for multiple boilers

12" minimum between edge of air intake pipe and adjacent vent pipe from another boiler



DIRECT VENT - Vertical Termination, continued (Category IV)

4. Vertical vent termination with sidewall air termination as shown in Figure 37:
 - a. Provide and install corrosion-resistant metal stop plates. See Figure 36, item 3.
 - b. The hole size in the stop plates must be just larger than the vent pipe diameter.
 - c. Obtain stop plates only from the vent pipe manufacturer.
 - d. Insert the last length of vent and air pipe from the outside. The shoulders of the vent and air pipe female ends must rest against the outer stop plates as shown. The plates must prevent the vent or air pipe from being pushed inward.
 - e. Attach the termination elbow into the air pipe end.
 - f. Install a bird screen from the vent manufacturer in the open end of the termination.
 - g. Seal exterior openings thoroughly with exterior caulk.

Figure 36 Vertical vent with sidewall air - sidewall air termination assembly

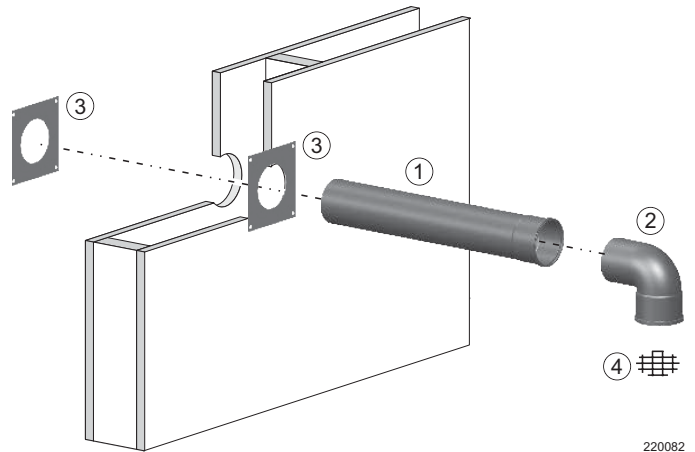

220082

- | | |
|---|---|
| 1. Air piping must extend through wall enough for complete engagement of the air termination elbow. | 3. Sidewall termination plates - hole must be just larger than the air pipe diameter. |
| 2. Air termination elbow - down-turned 90-degree. | 4. Bird screen, by installer. |

WARNING

For multiple boiler applications, space flue vents a minimum 6" apart from other flue vents, and air terminations a minimum 6" apart from other air terminations. Flue vents must maintain a 12" horizontal distance from air terminations. Failure to comply can result in severe personal injury, death, or substantial property damage.

Figure 37 Vertical vent with sidewall air - termination locations

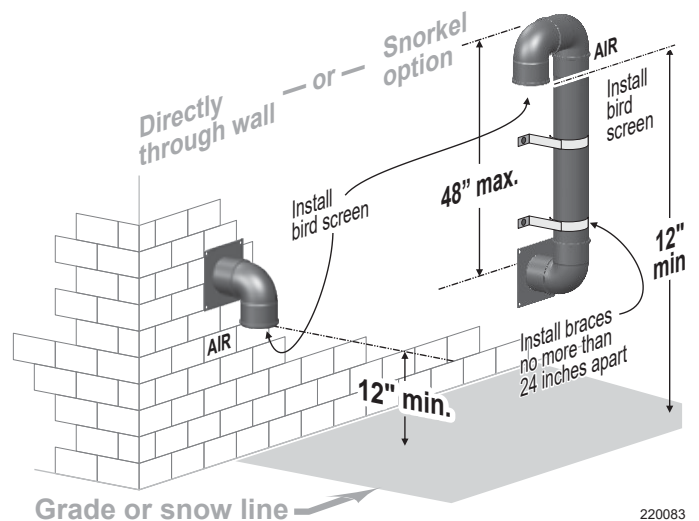
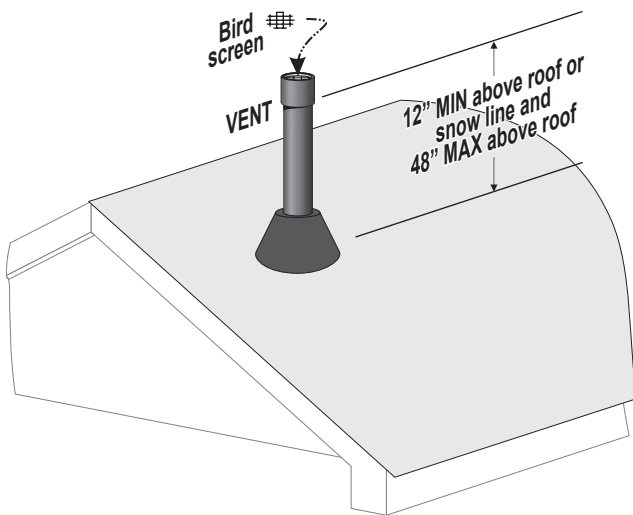

220083

Sidewall Termination Location

⚠ WARNING

Follow all location requirements in this section. Failure to comply can result in severe personal injury, death, or substantial property damage.

- The minimum distance from adjacent public walkways, adjacent buildings, windows that can open, and building openings shall not be less than the values specified in the National Fuel Gas Code – ANSI Z223.1/NFPA 54, latest edition, or the National Gas and Propane Installation code – CAN/CSA B149.1.

- Vent and air terminations must be installed at least 12" (0.31m) above grade and snow line.
- Consideration should be given to avoid possible damage caused by vent plumes and condensate when choosing a venting configuration and location.
- Maintain a minimum clearance of 4 ft. (1.22 m) horizontally from electrical meters, gas meters, regulators, and relief equipment. Do not install above or below meters, regulators, or relief equipment.

Figure 38 Direct Vent Installations - Requirements for termination location

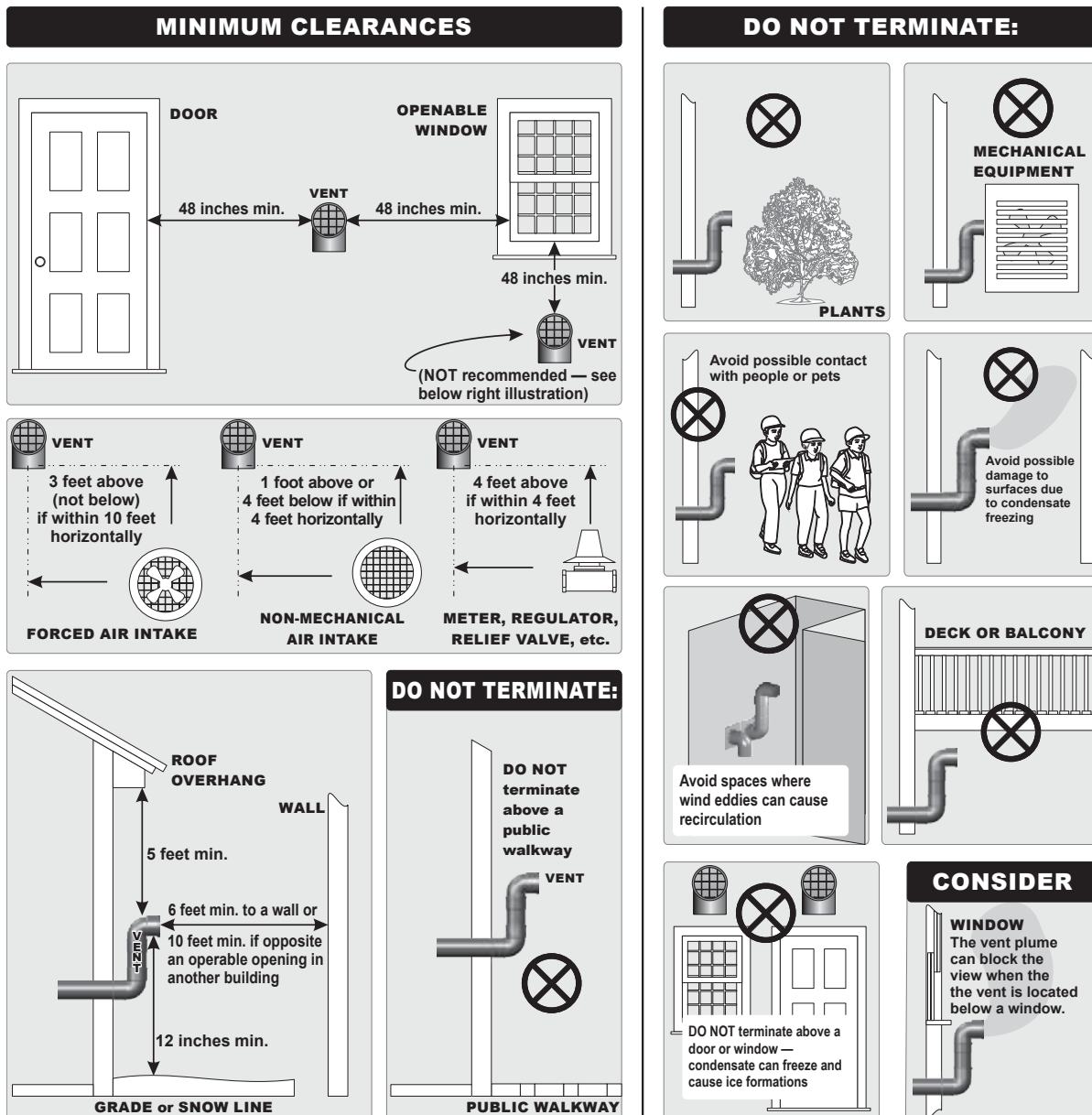

DIRECT VENT - Sidewall Termination (Category IV)

Determine Termination Location

The vent termination must be installed as shown in Figure 39 and Figure 41, page 54. The termination placement must comply with clearances and limitations shown in Figure 38, page 51.

1. Install the termination in a location where damage from foreign objects and buildup of leaves or sediment is unlikely.
2. Ensure proper clearance above grade or snow line. Keep vents and air area clear of accumulating snow.
3. Install the boiler in a location that allows proper routing of all vent piping from the boiler vent connection to the selected sidewall location.

⚠ WARNING

Locate the termination such that the total vent piping from the boiler to the termination will not exceed the maximum length given in Figure 24, page 37 for Category IV venting. Failure to comply can result in severe personal injury, death, or substantial property damage.

IMPORTANT

Read and follow all instructions in this manual. Do not proceed with vent installation until you have read pages 29-36, 45-46, & 52. Comply with all vent system manufacturer's instructions.

Multiple Vent Terminations

When terminating multiple SVF boilers, terminate each vent connection as described in this manual. See Figure 40, page 53 for typical layout.

For U.S. installations, place wall penetrations to obtain minimum clearances shown in Figure 39 and Figure 40, page 53.

In Canada, provide clearances required by Natural Gas and Propane Installation Code – CAN/CSA B149.1. Use a ULC S636-compliant vent kit.

Figure 39 Sidewall direct vent terminations

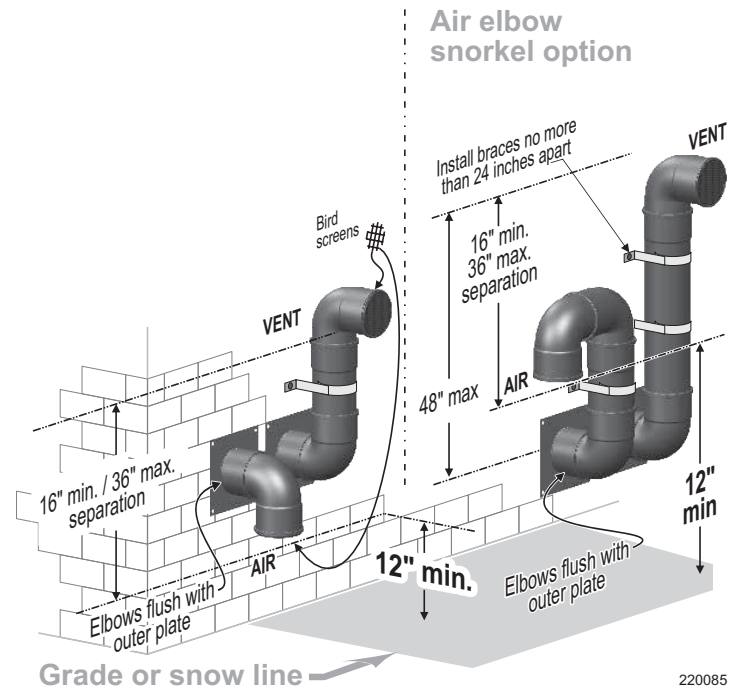

Vent Piping Installation

⚠ WARNING

Use sweep elbows for all vent and air piping. DO NOT use short-radius elbows for vent or air piping. Failure to comply can result in severe personal injury, death, or substantial property damage.

⚠ WARNING

Use only the vent materials and kits listed in Table 9, page 34. Failure to comply can result in severe personal injury, death, or substantial property damage.

⚠ WARNING

Every joint on polypropylene vent piping must include a locking collar. Failure to supply locking collars can cause vent or air piping leakage, which can result in severe personal injury, death, or substantial property damage.

1. Install a vent adapter if needed. Follow instructions from the vent manufacturer.
2. Install a reducer from a vent manufacturer if needed to adapt to the vent size.

3. Slope vent piping toward the boiler a minimum of 1/4" per foot in horizontal runs or larger per vent pipe manufacturer's instructions.
4. Support piping independently of the boiler. Install pipe supports every 5 ft. on both the horizontal and vertical runs. Install a hanger support within 6" of any upturn in the piping.
6. External venting greater than 4 ft. requires an insulated enclosure around the vent and air pipes. The vent and air terminations must exit through the enclosure while maintaining all required clearances. See [Figure 39, page 52](#).
7. Attach the exterior piping and termination elbows.
8. Install a bird screen from the vent manufacturer in the open end of the termination.
9. Seal exterior openings thoroughly with exterior caulk.
10. See [Figure 40](#) for multiple boiler terminations.

Vent Termination Installation

Maintain the required dimensions of the finished termination piping as shown in [Figure 38, page 51](#).

1. Cut a hole for the air pipe, sized per the air pipe manufacturer's instructions.
2. Vent pipe penetration
 - a. Cut a hole for the vent pipe
 - b. For combustible construction, size the vent pipe hole at least 3/8" larger than the vent pipe diameter. Size larger if specified by the vent manufacturer.
 - c. For noncombustible construction, size the opening per vent manufacturer's instructions.
 - d. Insert a corrosion-resistant metal thimble in the vent pipe hole as shown in [Figure 41](#).
 - e. Follow all local codes for isolation of vent pipe when passing through floors, ceilings, and roofs.
3. Provide and install corrosion-resistant metal stop plates. See [Figure 41, item 3](#).
 - a. The hole size in the stop plates must be just larger than the vent pipe diameter.
 - b. Obtain stop plates only from the vent pipe manufacturer.
4. Insert the last lengths of vent and air pipe from the outside. The shoulders of the vent and air pipe female ends must rest against the outer stop plates as shown. The plates must prevent the vent or air pipe from being pushed inward.
5. The vent and air pipes may run up as high as 4 ft. with no enclosure. The vent and air pipes must be secured with braces. All clearances and lengths must be maintained. Space braces no further than 24" apart.

Figure 40 Multiple terminations - clearance from vent of one to air intake of the next

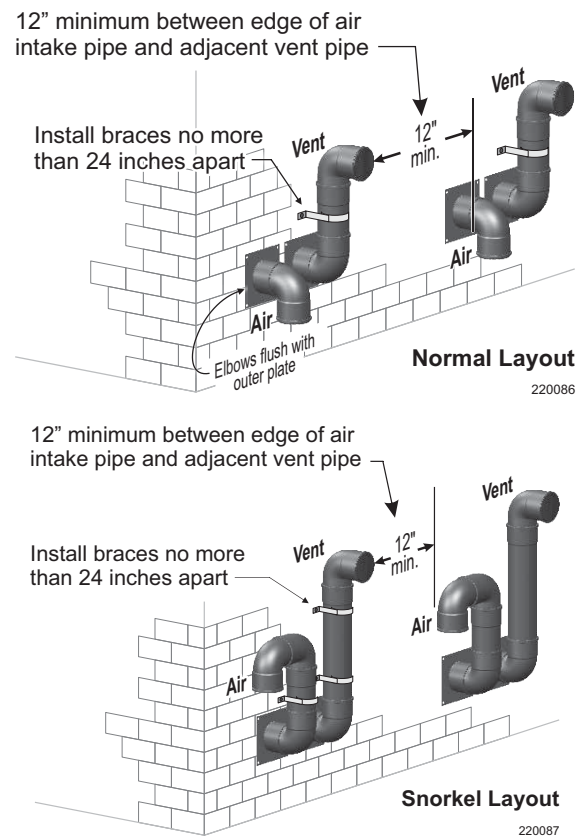

DIRECT VENT - Sidewall Termination, continued (Category IV)

Figure 41 Sidewall termination assembly for direct vent installations

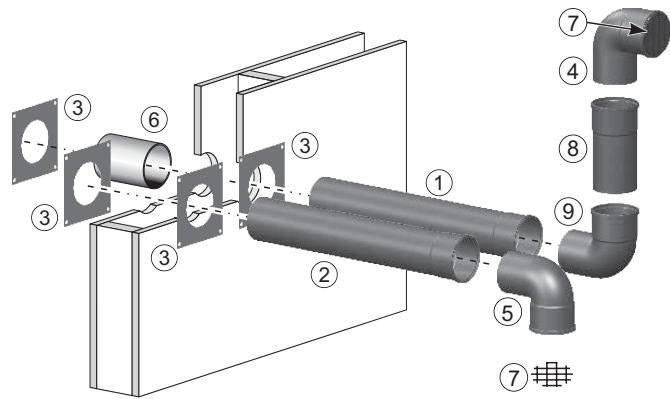

220088

- | | |
|--|---|
| 1. Insert vent piping from the outside until the female end shoulder rests against the outside stop plate. | 4. Vent termination elbow - outward-facing 90-degree. |
| 2. Insert air piping from the outside until the female end shoulder rests against the outside stop plate. | 5. Air termination elbow - down-turned 90-degree. |
| 3. Sidewall termination plates | 6. Corrosion-resistant thimble, by installer. |
| | 7. Bird screen, by installer. |
| | 8. Vent length |
| | 9. Elbow |

Install Condensate Components

Condensate Trap Installation

WARNING

The condensate trap must be in a vertical orientation and not wedged against the ground or any other object. If the trap is installed incorrectly, flue gas could leave through the condensate drain, which can result in severe personal injury or death.

1. Slide the end of the plastic condensate trap onto the drain on the back side of the boiler.
2. Tighten a hose clamp to secure the condensate trap to the drain pipe.
3. Secure the condensate bracket to the boiler base.
4. Slide the PVC tee through the bracket.
5. Ensure the second hose clamp is loosely installed over the right side of the trap. Slide the trap over the tee and up to the bracket. Slide the hose clamp up to the bracket and tighten.

Condensate Line Connection

1. Use 3/4" PVC or CPVC pipe to route condensate to a drain or condensate pump.
2. If installing a condensate pump, select one approved for use with condensing boilers and furnaces. The pump should have an over-flow switch to prevent property damage from spillage. Provide an external power source for the pump.
3. Minimum recommended condensate pump capacity in gallons per hour per boiler:
 - SVF 725, 15 GPH
 - SVF 850, 25 GPH
4. When sizing condensate pumps, make sure to include the total load of all SVF boilers connected.

NOTICE

The condensate line must remain unobstructed, allowing free flow of condensate. If condensate freezes or the line is obstructed, condensate can back up into the boiler, leading to boiler lockout.

IMPORTANT

Condensate from the boiler will be slightly acidic, typically 3.2 to 4.5 pH. Install a neutralizing filter if required by local codes. See the Parts section starting on [page 111](#) for a Weil-McLain condensate neutralizer kit.

Figure 42 Condensate trap assembly components

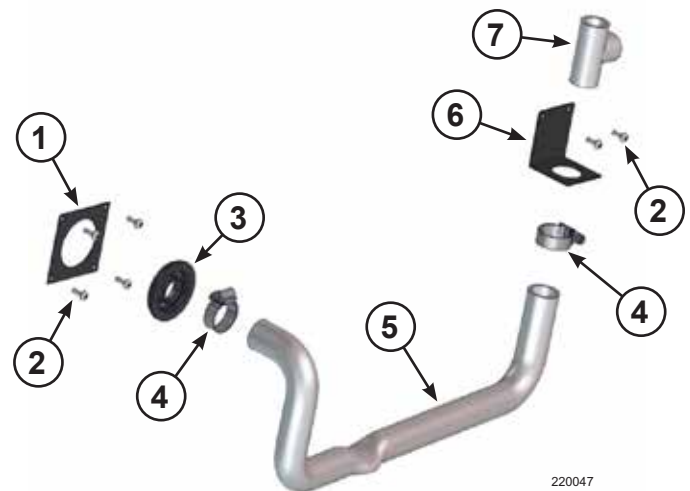

- | | |
|--------------------------|-----------------------|
| 1. Condensate Line Panel | 5. Condensate Trap |
| 2. #10 Torx Screw | 6. Condensate Bracket |
| 3. 3/4" Grommet | 7. 1/2" PVC Tee |
| 4. Hose Clamp | |

Figure 43 Condensate trap assembly, installed

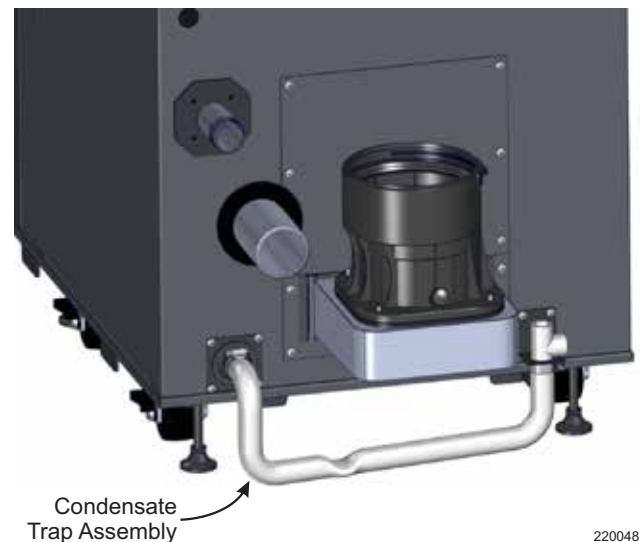

NOTICE

Use materials approved by the authority having jurisdiction. In the absence of other authority, PVC and CPVC pipe must comply with ASTM D1785, F441, or D2665. Cement and primer must comply with ASTM D2564 or F493. For Canada, use CSA or ULC certified PVC or CPVC pipe, fittings, and cement.

Gas Piping

Gas Supply Piping Connection

⚠WARNING

Use two wrenches when tightening gas piping at the boiler. Use one wrench to prevent the boiler gas line connection from turning. Failure to prevent the boiler connection pipe from turning could damage gas line components, which can result in severe personal injury, death, or substantial property damage.

1. Connect the gas supply piping to the boiler. See Figure 44.
 - a. Install a union for servicing when required.
 - b. Install a manual shutoff valve in the gas supply piping within 6 ft. of the boiler.
 - c. In Canada, the manual gas valve must be identified by the installer.
2. Support gas piping with hangers or other devices. Do not support the piping by the boiler or boiler accessories.
3. Use pipe dope compatible with propane gases as natural gas may contain some propane. Apply pipe dope sparingly only to male threads of pipe joints so that it does not block gas flow.

⚠WARNING

Apply pipe dope as detailed in this section. Failure to apply pipe dope properly can result in severe personal injury, death, or substantial property damage.

⚠WARNING

SVF boilers are shipped ready to fire natural gas ONLY. The propane conversion kit must be installed if the boiler will be connected to propane. See [page 16](#) for instructions. Failure to comply can result in severe personal injury, death, or substantial property damage.

4. If any factory installed gas connections are altered during installation, make sure to check for leaks before operation. See [page 57](#) for more information on checking for leaks.

Figure 44 Gas supply piping connection (fittings and gas valve supplied by installer)

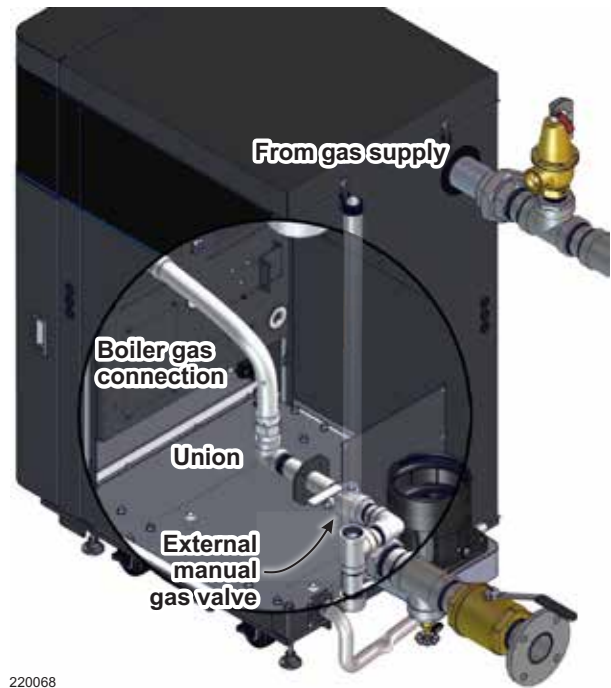

220068

5. If inlet pressure can exceed 14" W.C. at any time:
 - a. Install a 100% lock up gas pressure regulator as defined by ANSI Z21.80 in the gas supply line. Lock up regulators can have pressure spikes of 5" W.C. or 150% of setting, whichever is greater.
 - b. Adjust the lock up regulator for inlet pressure below 10" W.C. with the boiler at minimum input rate. This setting provides a cushion below the setting of the high gas pressure switch.
 - c. Gas pressure can be adjusted higher or lower as needed.

⚠WARNING

A lock up regulator must be installed as detailed if inlet pressure can exceed 14" W.C. Failure to comply can result in severe personal injury, death, or substantial property damage.

Check Natural or LP Gas Supply Pressure

1. Purge all air from the gas supply piping.
2. Check the boiler and its gas connection for leaks before placing the boiler in operation.
 - a. Close manual main shutoff valve during any pressure testing at less than 14" W.C.
 - b. Disconnect the boiler gas connection from the gas supply piping during any pressure testing greater than 14" W.C.

WARNING

DO NOT check for gas leaks with an open flame; Gas leaks can result in an explosive atmosphere Use a soapy water bubble test to check for gas leaks. Failure to follow these instructions can result in severe personal injury, death, or substantial property damage.

3. Connect a manometer or pressure gauge to the tapping on the gas line elbow by the gas valve. See Figure 45.
4. Verify minimum gas pressure when all gas appliances are in operation. The pressure at the gas valve test port is as follows:
 - a. Minimum gas pressure required with gas flowing = 3.5" W.C. Verify during boiler startup while boiler is at high fire.
 - b. Maximum gas pressure is certified to 14" W.C., whether the boiler is running or turned off. See [page 56](#) for installation of a 100% lock up regulator as necessary

Gas Train Diagram

Figure 46 Gas train diagram

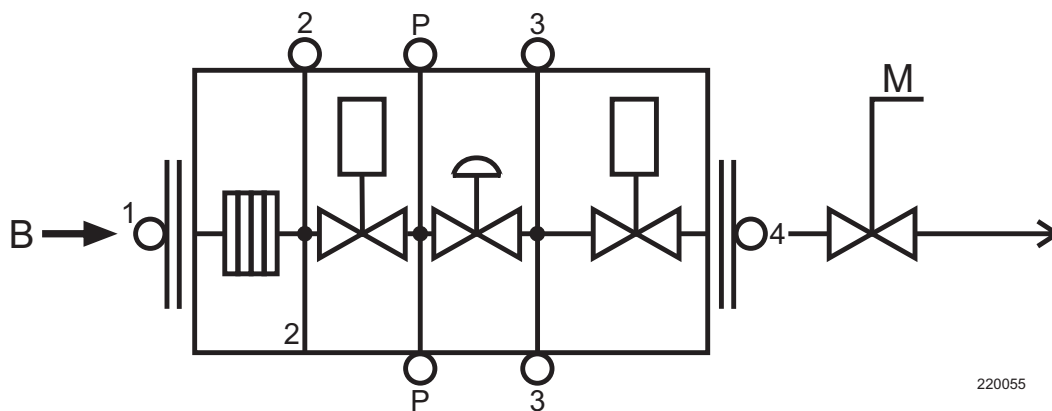

Legend	
Port 2	- Pressure after inlet screen
Port P	- Unregulated intermediate pressure
Port 3	- Regulated intermediate pressure
M	- Manual shut off (high gas switch location)
B	- Internal boiler piping (low gas switch location)



Figure 45 Gas line tapping

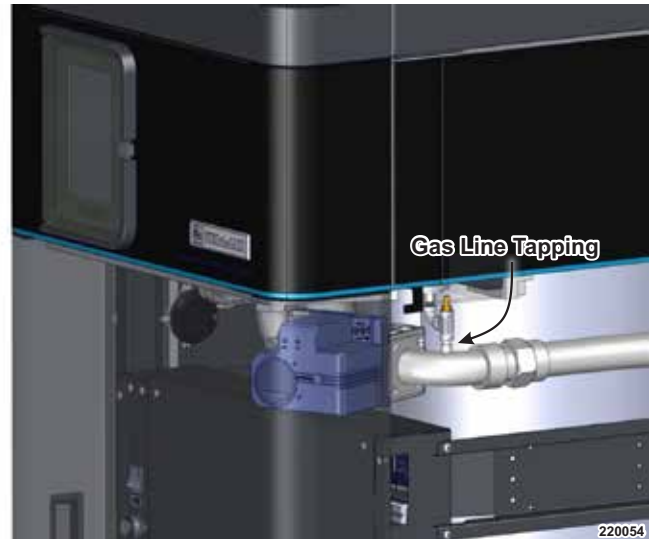

Gas Piping, continued

Pipe Sizing for Natural Gas

1. Size gas supply piping from meter outlet to the entrance of the boiler in accordance with Table 11 and Table 12.
2. Divide the total input in Btuh of all connected appliances by 1,000 to obtain approximate cubic feet per hour of natural gas.
 - a. Pipe lengths in Table 11 are equivalent lengths of straight pipe. Use Table 12 to determine equivalent length of fittings. Add the total straight pipe with the equivalent lengths of the fittings to determine the gas pipe total length.
 - b. Table 11 is only for natural gas with specific gravity 0.60, with a pressure drop through the gas piping of 0.30" W.C.
 - c. For additional gas pipe sizing information, refer to ANSI Z223.1/NFPA 54, latest edition. In Canada, refer to the National Gas and Propane Installation Code – CAN/CSA B149.1.

Pipe Sizing for Propane Gas

Ensure the boiler is converted to propane per instructions on [page 16](#). Contact the gas supplier to size pipes, tanks, and 100% lock up gas pressure regulators. Gas pipe must be properly sized with a 100% lock up gas pressure regulator in the gas supply line. An undersized gas pipe feeding the boiler can cause issues.

Multiple Boiler Applications - Manifolder Gas Supply Lines

1. Size the gas supply piping as instructed above.
2. Provide a manual shutoff gas valve, union, and sediment trap (minimum 3" below tee) at each boiler as shown in [Figure 44](#), [page 56](#).
3. Ensure the piping is large enough to meet the minimum pressure requirement at each boiler as specified on [page 57](#).

Table 11 Pipe capacity for natural gas

Gas Pipe Total Length (ft.)	Gas Supply Pipe Capacity (cubic feet per hour) @ 0.30" W.C. pressure drop (cubic feet per hour, 0.60 specific gravity)			
	2"	2.5"	3"	4"
10	3050	4800	8500	17500
20	2100	3300	5900	12000
30	1650	2700	4700	9700
40	1450	2300	4100	8300
50	1270	2000	3600	7400
70	1050	1700	3000	6200
100	870	1400	2500	5100
150	710	1130	2000	4100

Table 12 Equivalent lengths for gas line fittings

Pipe Size	Equivalent Length (ft.)	
	90° Elbow	Tee
2"	5.17	10.30
2.5"	6.16	12.30
3"	7.67	15.30
4"	10.10	20.20

Gas Pressure Switches

SVF boilers are equipped with high and low gas pressure switches. A fault will occur if either switch is activated, and it will need to be reset at the control. The switch will automatically return to normal operating state once gas pressure is returned to normal operating range. These switches are factory set and should remain at the following settings.

- High gas pressure switch: 1" W.C.
- Low gas pressure switch: 2" W.C.

SECTION 3

Electrical

This section is intended to provide wiring and zoning instructions for qualified installers and service contractors.

Section Contents

Electrical - General	59
Field Wiring	61

Electrical - General

⚠WARNING

Turn off electrical power supply at the service entrance panel before making any electrical connections. Failure to turn off the electrical power can cause electric shock, which can result in severe personal injury or death.

NOTICE

Do not use 24V from a transformer to power any external devices that are not listed in this manual.

The installation must comply with the National Electrical Code and any other national, state, provincial, or local codes and regulations. In Canada, comply with Canadian Electrical Code, Part 1 – CSA C22.1, and any other local codes.

⚠WARNING

Wiring errors can cause improper and dangerous operation. Label all wires to ensure proper connection. Never jumper (bypass) any device except for momentary testing. Failure to comply can result in severe personal injury, death, or substantial property damage.

Wiring must be N.E.C. Class 1. If original wiring supplied with the boiler must be replaced, use only type 105°C wire or equivalent. The boiler must be electrically grounded as required by the National Electrical Code – ANSI/NFPA 70, latest edition, or the Canadian Electrical Code, Part 1 – CSA C22.1.

The boiler must be electrically bonded to ground when installed in accordance with the requirements of the authority having jurisdiction. In the absence of such requirements, comply with the requirements in the National Electrical Code – ANSI/NFPA 70, latest edition, or the Canadian Electrical Code, Part 1 – CSA C22.1.

Seal all electrical entrances. Use a sealed strain relief, or a strain relief sealed with duct seal putty or silicone. Sealing the entrances prevents the boiler from drawing air from inside the boiler room; this is particularly important if the boiler is located in the same room as other gas appliances.

⚠WARNING

All electrical entrances must be sealed. Unsealed entrances can draw air from inside the room, which can result in severe personal injury, death, or substantial property damage.



Electrical - General, continued

Power Requirements

- The SVF 725-850 boilers are manufactured for 120 VAC, 60 Hz electrical service.
- The total operating amperage indicated on the nameplate requires less than 10 Amps at full load.
- Before starting the boiler, ensure the proper electrical service is connected to the boiler.
- An external electrical disconnect and overload protection (not supplied with the boiler) **are required**.

3 The electrical service to the boiler must be installed and grounded in accordance with local codes. In the absence of such requirements, comply with National Electrical Codes – ANSI/NFPA No. 70, latest edition, in the U.S. In Canada, comply with the Canadian Electrical Code, Part 1 – CSA C22.1, latest edition. The installed conduit must not block any of the boiler's openings and must allow space to open the front door.

Power Supply Connections

The SVF 725 and 850 models feature three dedicated power terminals on the High Voltage (TB2) terminal block for the 120 VAC, 60 Hz electrical supply. See Figure 47 for the location of the Low Voltage (TB1) and High Voltage (TB2) terminal blocks. The front door is hidden in the figure for clarity.

- TB2 Terminal 1 = HOT L1
- TB2 Terminal 3 = NEUTRAL N1
- TB2 Terminal 4 = GROUND G1

Figure 47 Terminal block locations

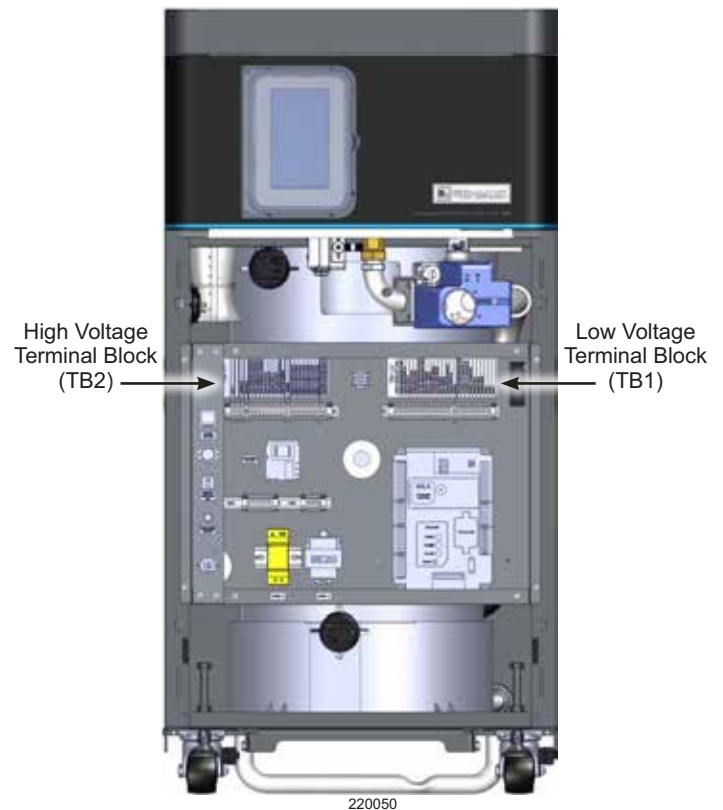

Field Wiring

The figures below show the high and low voltage terminal block wiring used in this section. Also refer to the schematic and ladder diagrams, [Figure 50, page 62](#) and [Figure 51, page 64](#).

Figure 48 High voltage (TB2) terminal block wiring section

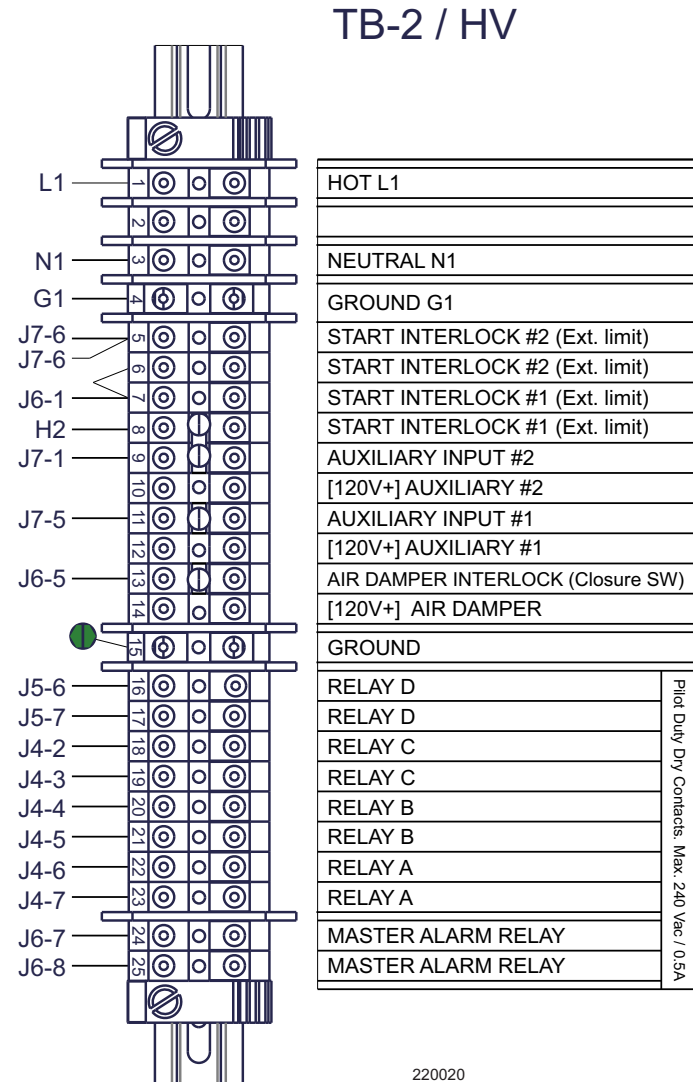
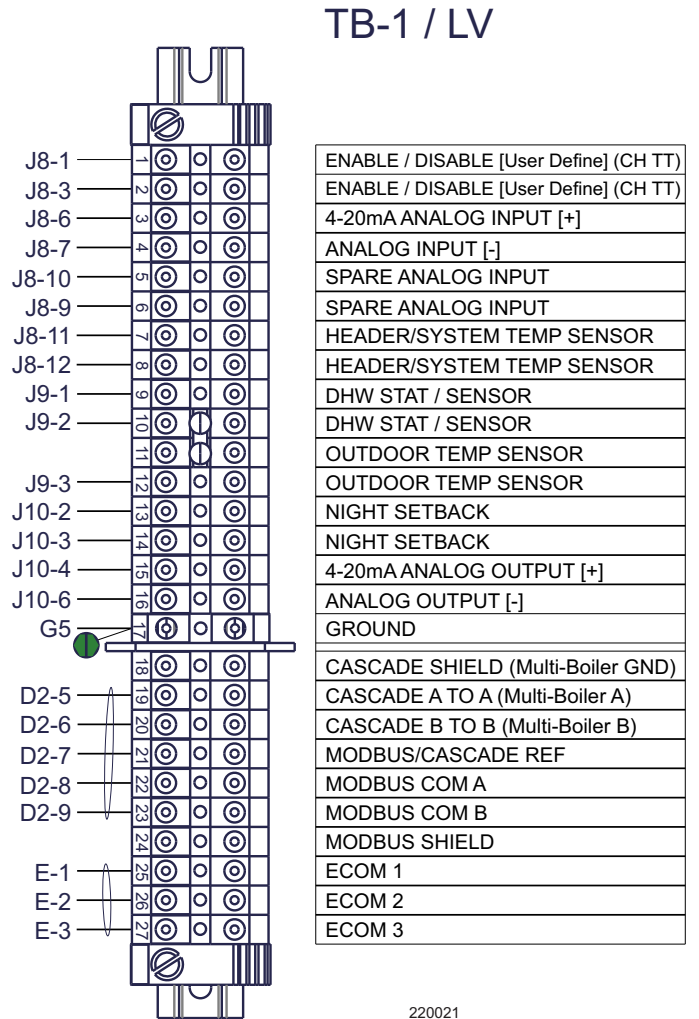

Figure 49 Low voltage (TB1) terminal block wiring section



Field Wiring, continued

Schematic Diagram

Figure 50 Schematic wiring diagram for SVF boilers (continued on the next page)

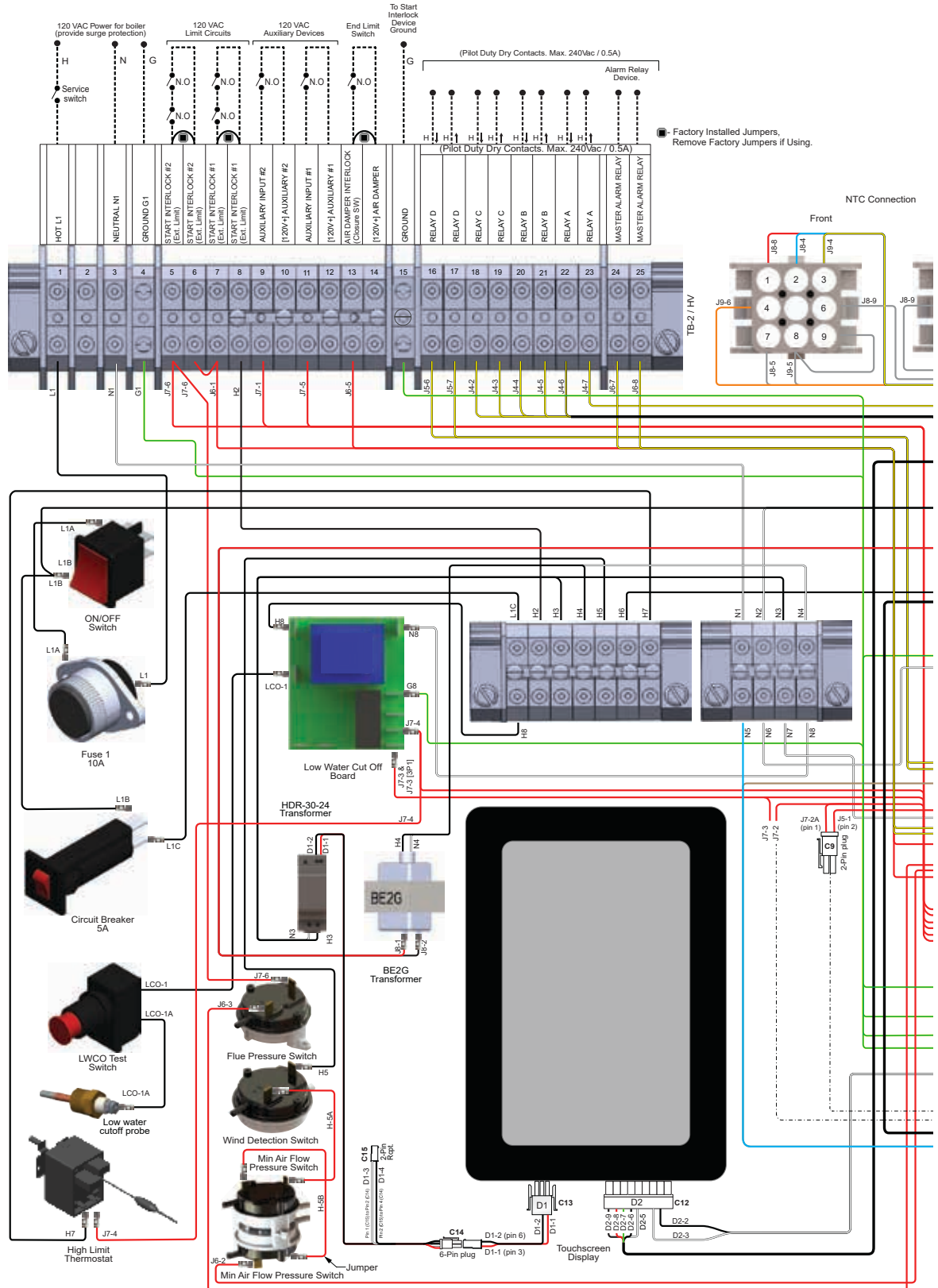

3



Schematic Diagram, continued

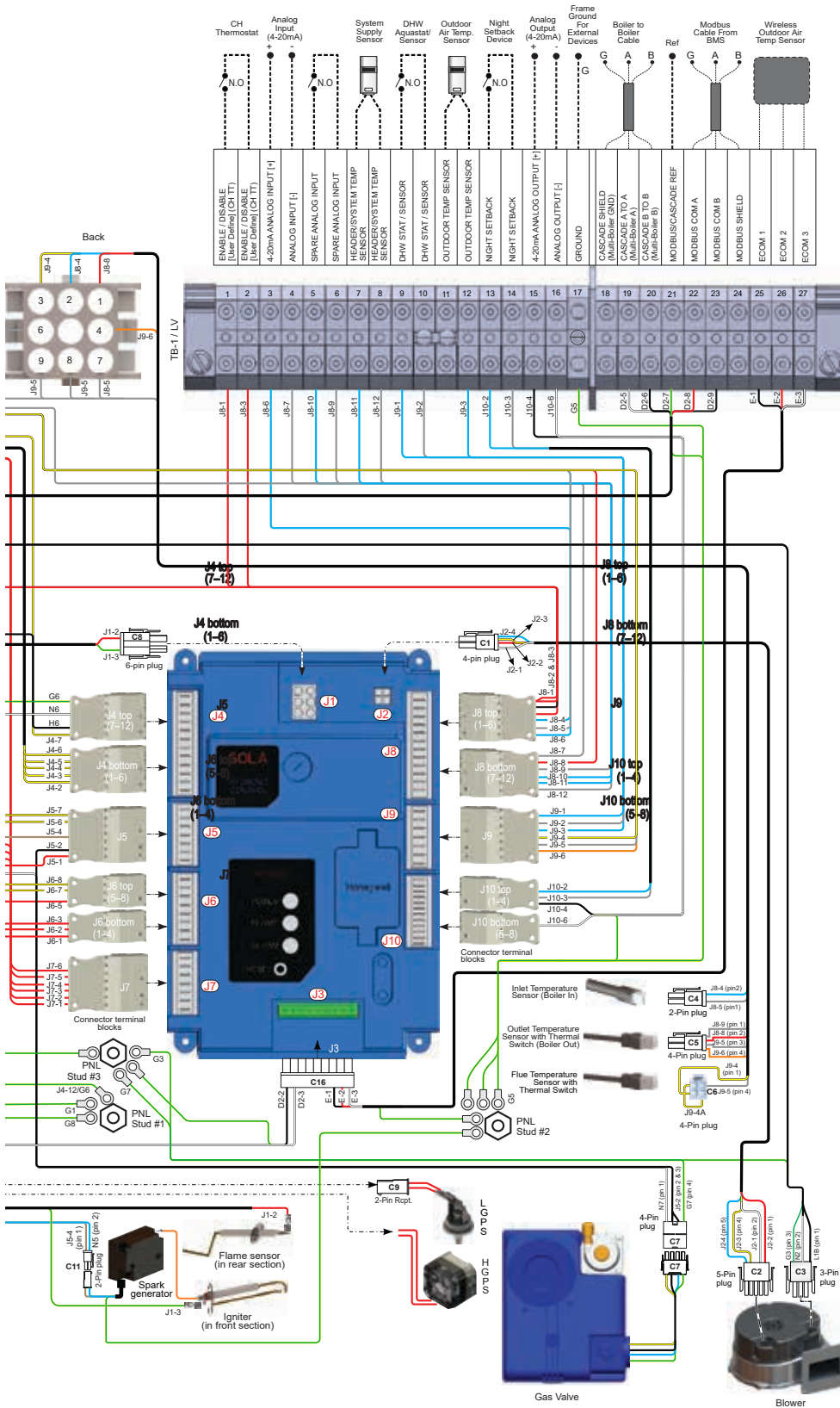



WEIL-McLAIN
Weil-McLain • 500 Blair St. • Michigan City, IN 46360-2388
Part Number 550201620/0124



Schematic Wiring Diagram

Field wiring Factory wiring

See ladder wiring diagram for notes

SVF™ Commercial Boiler
Single Phase 725/850



Ladder Diagram, continued

SVF™**725/850****Ladder Wiring Diagram****⚠ WARNING**







Electrical shock hazard — can cause severe injury or death. Disconnect power before installing or servicing.

NOTICE

All contacts shown without power applied.

- ✱ Indicates items not provided
- Indicates Factory Installed Jumpers, Remove Factory Jumpers if Using.

Legend for ladder wiring diagram only

	120 vac field wiring
	Low voltage field wiring
	120 vac factory wiring
	Low voltage factory wiring
	High voltage spark ignition wiring
	Ground connectors

Notes for Schematic and Ladder Wiring Diagrams

- All wiring must be installed in accordance with:
 - U.S.A. — N.E.C. And any other national, state, or local code requirements.
 - Canada — C.S.A. C22.1 C.E.C. Part 1 and any other national, provincial, or local code requirements.
- If any of the original wire as supplied with the appliance must be replaced, use minimum 105 °C wire or equivalent. Exceptions: Ignition lead wire must be obtained from Weil-McLain only.
- Thermostat anticipator setting (single zone) — set anticipator for 0.1 amps.
- Provide power source to boiler that is protected by a surge protector. Amperage requirements for boilers are:
 - SVF-725 — <10 amps
 - SVF-850 — <10 amps
 Fuse or breaker rating must not exceed 15 amps.

**WEIL-McLAIN**

Weil-McLain • 500 Blaine St. • Michigan City, IN 46360-2388

Part Number

550201622/0624



Field Wiring, continued

A. Power Supply — *REQUIRED*

- HOT L1 - Connect the hot lead of the 120 VAC, 60 Hz electrical service to the TB2-1 terminal.
- NEUTRAL N1 - Connect the neutral lead of the 120 VAC, 60 Hz electrical service to the TB2-3 terminal.
- GROUND G1 - Connect the ground lead of the 120 VAC, 60 Hz electrical service to the TB2-4 terminal.
- Provide and install a fused disconnect or service switch as required by applicable code. Boiler load is rated at <10 Amps.

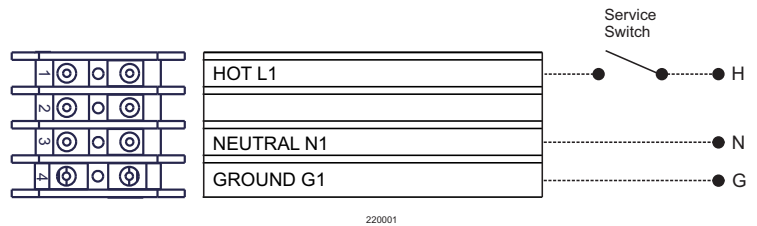

B. Start Interlocks (Manual/Auto Limit) – *As needed for systems*

- START INTERLOCK #1 and #2 - The Start Interlock #1 TB2-7 and TB2-8, and Start Interlock #2 TB2-5 and TB2-6 terminals can be used for auxiliary safety devices such as damper limit switches, control valve limit switches, emergency stop buttons, and low water cutoff devices.
- This circuit is energized with 120 VAC, so the contacts on any auxiliary safety devices must be rated for a minimum of 120 VAC.
- The appliance ships with a factory-installed jumper across Start Interlock #1 and #2 terminals.

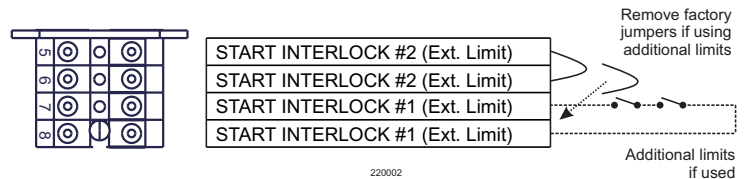

IMPORTANT

The Start Interlock circuit must close within five minutes of a call for heat. Failure to close the Start Interlock circuit will cause the appliance to lock out on alarm.

C. Auxiliary Inputs #1 and #2 – *As needed for systems*

- Auxiliary Inputs #1 are on terminals TB2-11 and TB2-12.
- Auxiliary Inputs #2 are on terminals TB2-9 and TB2-10.
- These circuits are energized with 120 VAC.

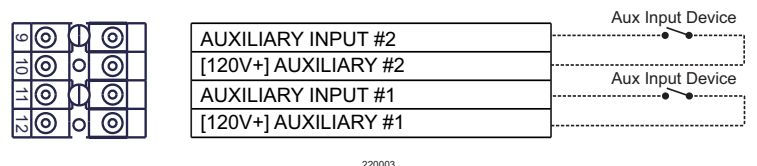

D. Air Damper Interlock (Closure Switch) – As needed for systems

- The Air Damper Interlock on TB2-13 and TB2-14 terminals allow for proof of open end limit switch on a motorized air damper.
- This circuit is energized by 120 VAC, so the contacts on the end limit switch must be rated for a minimum of 120 VAC.
- Depending on the user-configuration, Relay A, Relay B, or Relay C can be selected to operate the combustion air damper. See section F for more information.

NOTICE

The appliance ships with a factory-installed jumper across the Air Damper Interlock terminals. Remove the jumper if connecting a motorized air damper with an end limit switch.

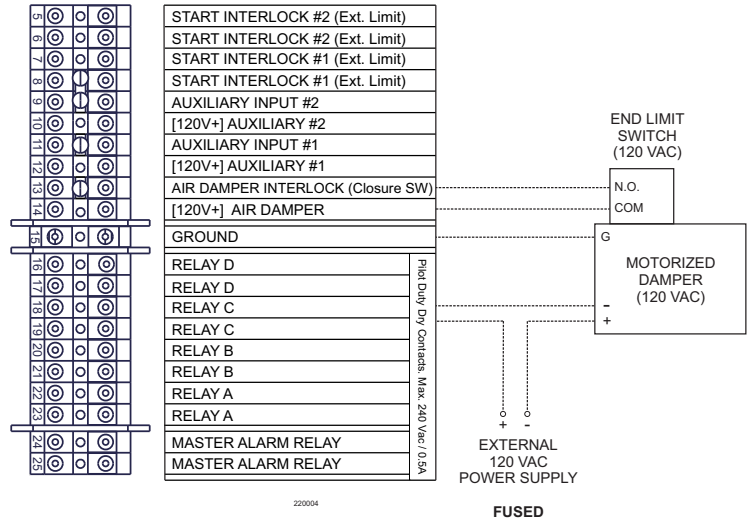

E. Ground, High Voltage – As needed for systems

- Grounding connection for auxiliary safety and limit devices on terminal TB2-15.
- This ground terminal is connected to the TB2 sheet metal. It is not common with the appliance’s electrical service ground.



Field Wiring, continued

F. Relay A, B, C, and D (120 VAC Pilot Duty Dry Contacts) – As needed for systems

⚠ WARNING

External power supplies are required for Relays A, B, C, and D. Power is still present when the appliance is turned off. All voltage sources must be disconnected prior to servicing. Failure to comply can cause electrocution, resulting in severe injury or death.

- User-configurable relay 120 VAC pilot duty dry contacts.
 - › Relay A: TB2-22 and TB2-23
 - › Relay B: TB2-20 and TB2-21
 - › Relay C: TB2-18 and TB2-19
 - › Relay D: TB2-16 and TB2-17
- The normally-open contacts on these relays have a maximum voltage of 240 VAC and a maximum current capacity of 1/2 Amp.

NOTICE

Customer must supply fusing for all current connected to the relays. Connecting a motorized damper which exceeds the voltage or current capacity of the relay as stated in this section could cause permanent damage to the relay.

- Relays A through D can be user-configured through the control touchscreen interface to control devices such as the CH pump, Domestic Hot Water pump, Air Damper, and System Pump.

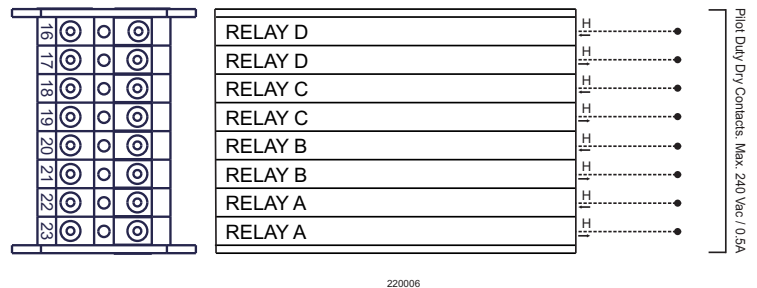

G. Master Alarm Relay (Alarm Contacts) – As needed for systems

- The Master Alarm Relay (Alarm Contact) terminals on TB2-24 and TB2-25 are normally-open dry contacts that close in the event of an alarm output from the control.
- The normally-open contacts on this relay have a maximum voltage rating of 240 VAC and maximum current capacity of 1/2 Amp.

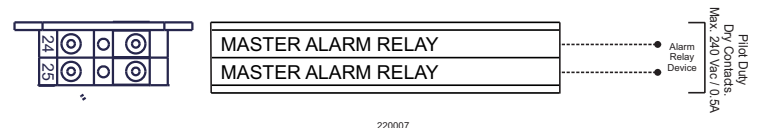

H. Enable/Disable (CH TT Input) – As needed for systems

- Contact closure enables comfort heat operation.
- Open circuit disables comfort heat operation.

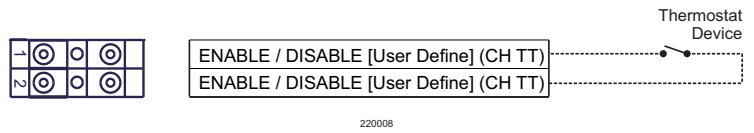

I. 4-20mA Analog Input (4-20mA Remote Setpoint or Modulation) – As needed for systems

- 4-20mA analog input configurable for Setpoint or Firing Rate Control (modulation).
- Target Setpoint is used to adjust the supply target temperature.
- Firing Rate Control is used to directly control the modulation rate of the boiler.

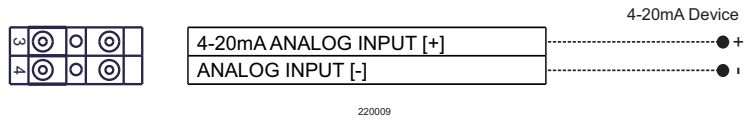

J. Spare Analog Input

- Not used. Reserved for future use.

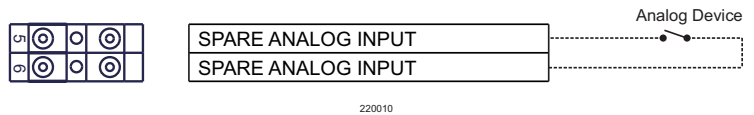

K. HDR Temp Sensor (System Supply) – As needed for systems

- TB1-7 and TB1-8 can be used to connect a remote header temperature sensor.
- Install the Temperature sensor in the primary hydronic system piping downstream of all boilers.
- This temperature sensor must be a 2-wire 12kOhm NTC thermistor.
- This circuit is energized by the boiler with a 5 VDC potential.



Field Wiring, continued

L. DHW Stat or Sensor – As needed for systems

- TB1-9 and TB1-10 can be used to connect either an aquastat or remote DHW temperature sensor installed in a domestic hot water storage tank.
- If using an aquastat, use a break on rise, SPST normally-closed type, with either a fixed or adjustable deadband above and below the setpoint.
- If using a temperature sensor, it must be a 2-wire 12kOhm NTC thermistor. It also has to be of sufficient length to measure an accurate storage tank temperature.
- This circuit is energized by the boiler with a 5 VDC potential.

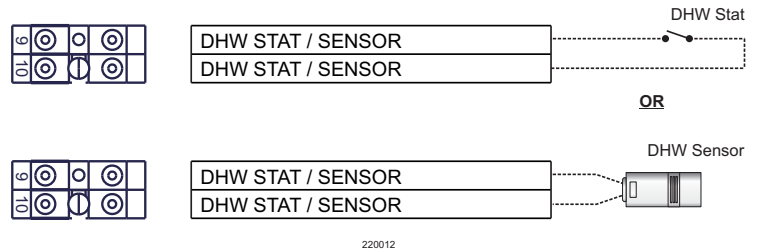

M. Outdoor Temperature (ODT) Sensor – As needed for systems

- TB1-11 and TB1-12 can be used to connect an ODT sensor, which allows the control to be programmed to run an outdoor air schedule.
- The ODT sensor must be a 2-wire 12kOhm NTC thermistor.
- The ODT should be installed on the North face of the building and shielded from direct sunlight exposure.
- This circuit is energized by the boiler with a 5 VDC potential.

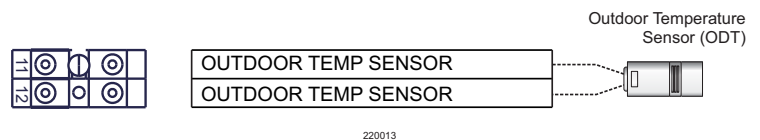

N. Night Setback – As needed for systems

- TB1-13 and TB1-14 can be used to connect a day/night or occupancy timer.
- Closure of the Night Setback circuit enables the night Setback mode.
- Night Setback reduces the boiler's operating setpoint.
- Opening this circuit resumes normal operation.
- This circuit is energized by the boiler with a 5 VDC potential. The contacts on the day/night timer must be rated for a minimum 5 VDC.

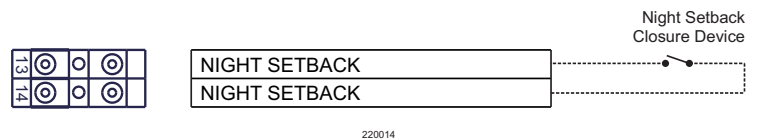

O. 4-20mA Analog Output – As needed for systems

- TB1-15 and TB1-16 provide a 4-20mA analog output signal, which tracks the boiler’s firing rate.
- When operating at full power (maximum firing rate), the boiler will provide a 20mA output.
 - › 100% = 20mA
- When operating at minimum power (minimum firing rate), the boiler will provide a 4mA output.
 - › 1% = 4mA
- For systems requiring 2-10v operation, install a 500 ohm resistor across the 4-20mA output terminals.

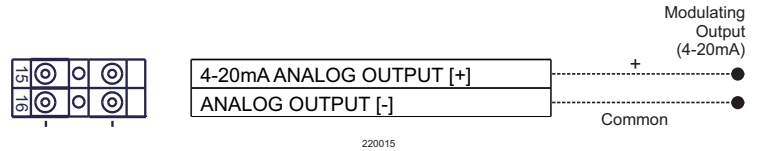

P. Ground, Low Voltage – As needed for systems

- TB1-17 provides an equipment (frame) ground connection for input, output, or communication connections.
- For independently powered control devices, it may be necessary to create a common ground.

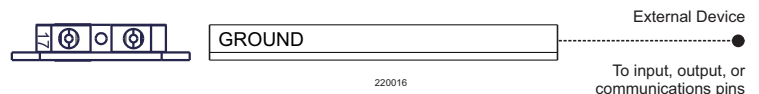

Q. Cascade Shield, A to A, and B to B (Multi-boiler A, B, Ground) – As needed for systems

- TB1-18, TB1-19, and TB1-20 can be used to set up a cascade system with multiple SVF boilers with the control.
- Terminals TB1-19 and TB1-20 are reserved for the cascade communications between the master and member (shadow) boilers.
- Terminal TB1-18 should be used to connect the cascade communication wiring shield between all boilers.
- The cascade and shielding must be wired from the master boiler to each individual member (shadow) boiler in a daisy-chain fashion.

⚠ WARNING

Cascade field wiring must utilize twisted pair shielded cable. For multi-boiler installations, JUMPER the field cascade shield connection TB1-18 to TB1-17 ground in the master boiler’s Control Panel. Do not ground shield to any other boiler or piece of equipment. Shield should be continuous from beginning to end with a ground connection in the master boiler only. Failure to comply can result in severe personal injury, death, or substantial property damage.

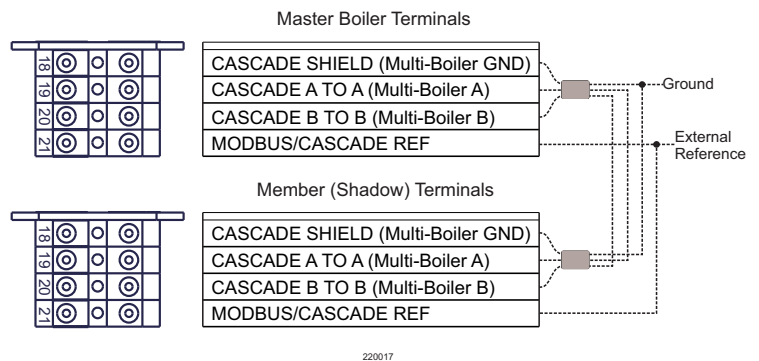

Field Wiring, continued

R. MODBUS Com A, B, and Shield – As needed for systems

- TB1-22, TB1-23, and TB1-24 can be used to integrate the boiler with a Building Management System (BMS), Protocol Converter, or other device capable of RS-485 2-wire MODBUS® communication.
- Terminals TB1-22 and TB1-23 are reserved for MODBUS and terminal TB1-24 provides a connection for the MODBUS communication wire shield.

⚠ WARNING

MODBUS field wiring must utilize twisted pair shielded cable. For multi-boiler installations, JUMPER the field MODBUS connection TB1-24 to TB1-17 ground in the master boiler's Control Panel. Do not ground shield to any other boiler or piece of equipment. Shield should be continuous from beginning to end with a ground connection in the master boiler only. Failure to comply can result in severe personal injury, death, or substantial property damage.

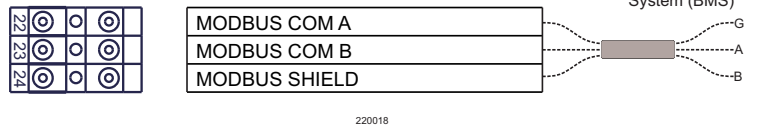

S. ECOM 1, 2, and 3 – As needed for systems

- TB1-25, TB1-26, and TB1-27 can be used to connect a wireless ODT sensor.
- The wireless receiver should be installed at or near the boiler.
- The wireless temperature sensor should be installed on the North face of the building and shielded from direct sunlight exposure.



3

SECTION 4

Operation

This section is intended to provide instructions for control setup and boiler startup procedures.

Section Contents

Control Setup and Operation	73
Startup - Fill the System	79
Startup - Final Checks	82
Startup Procedure	85

Control Setup and Operation

This manual covers basic boiler control operation and setup. Refer to the SVF Advanced Manual (part number 550-100-292) for a walk-through of the complete control setup for more complex boiler applications.

Control Startup

When the boiler is powered on, the control touchscreen will display an initial Startup screen. The Local Representative screen displays next, which shows the name, address, and phone number of the local WM Technologies service representative.

Home Screen

After a brief time, the Local Representative screen (Figure 52) will timeout, and the Home screen is displayed. The Home Screen shows a snapshot of the current operating conditions (Figure 53).

- Press the <Info> button to load the Information screen.
- Press the <Settings> button to load the Settings menu and access the setup wizard.

Figure 52 Local Representative screen



220043

Figure 53 Home screen



220044

Control Setup and Operation, continued

Information Screen

The Information screen (Figure 54) contains real-time, read-only values such as temperatures and relay states. This screen is helpful in determining the operating characteristics. Slide up or down on the touchscreen to scroll through the Information screen.

Setup Wizard

The Setup Wizard is recommended for all boilers. The Setup Wizard guides users through the parameter setup for all relevant applications based on the responses to a series of questions. The Setup Wizard is accessible through the Settings menu.

While navigating the Setup Wizard, press the desired buttons in the center content area. The selected choice will be indicated with a yellow light as seen in Figure 55. To proceed to the next Setup Wizard screen, press <Next> at the bottom of the screen. Press <Previous> to go back to the previous screen.

The Setup Wizard allows the user to assign functionality to the user-configurable Relays A to D. Functions such as boiler pump, system pump, flame detected, and air damper can be assigned to the relays.

NOTICE

The relay assignments *must* agree with the wiring to and from the appliance. For example, if Relay A is configured to enable/disable the boiler pump, the control wires to operate the boiler pump must be properly wired to the Relay A terminals in the High Voltage (TB2) terminal block.

Figure 54 Information screen

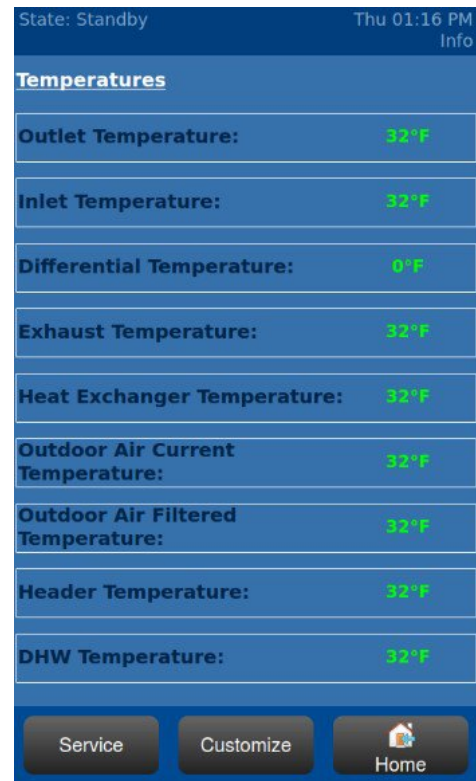

220045

Figure 55 Settings screen

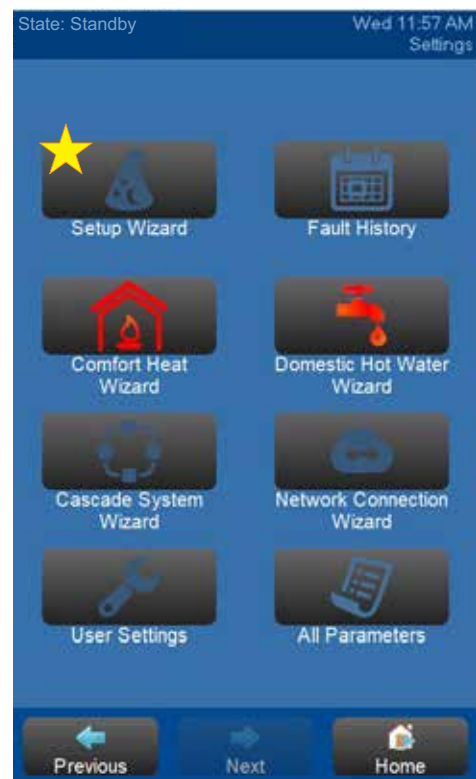

220046

High Altitude Fan Speed Setup

WARNING

Do not adjust the ignition RPM or other fan settings except as outlined in this section. High altitude installation will require ignition RPM adjustment based on [Table 14, page 107](#). Failure to comply can result in severe personal injury, death, or substantial property damage.

If the boiler is installed at an elevation of 2,000 ft. or greater, the fan speeds must be modified through the control using the information on [Table 14, page 107](#). Do not adjust ignition RPM unless at altitude.

1. From any screen after initial startup, click on the <Home> button at the bottom right of the display.
2. Navigate to the General Boiler Settings by clicking buttons through the next screens according to the following path:
 Settings > All Parameters > Boiler Settings > General Boiler Settings.
 See [Figure 53, page 73](#), [Figure 55, page 74](#), and [Figure 56](#).
3. Select <Service Level> at the bottom of the screen to modify the boiler fan settings. Refer to [Figure 57](#).
 - a. Select <Service Level 2>.
 - b. Enter 0555 for the password.
 - c. Click <Accept Password>.
 - d. Once the password is accepted, click the <Previous> button.
4. A "Modify" button now appears next to each parameter. Adjust the "Min Fan Speed" and "Ignition Fan Speed" parameters for high altitude. See [Figure 58](#).
 - a. Click the <Modify> button next to a parameter to change the value.
 - b. Use the arrows, yellow slider, or tap and type the value into the box to change the parameter.
 - c. Enter the value needed based on [Table 14, page 107](#).
 - d. Select <Accept> to complete the value change.
 - e. Repeat steps a-d to change the value of the next parameter.

(continued on the next page)

Figure 56 All Parameters and Boiler Settings screens

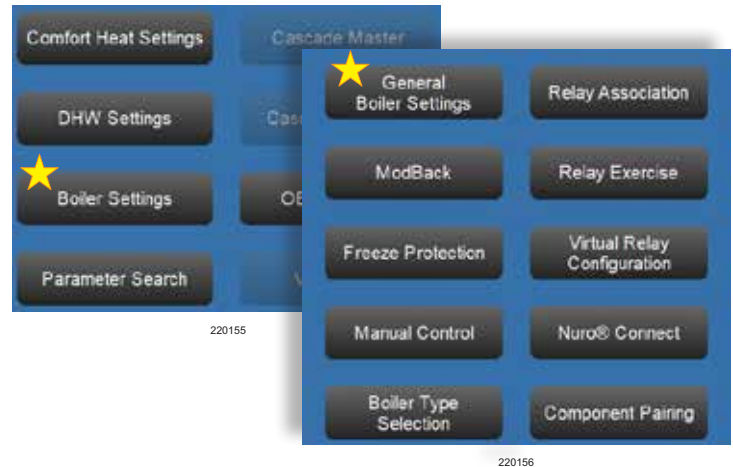

Figure 57 Enable fan speed modification

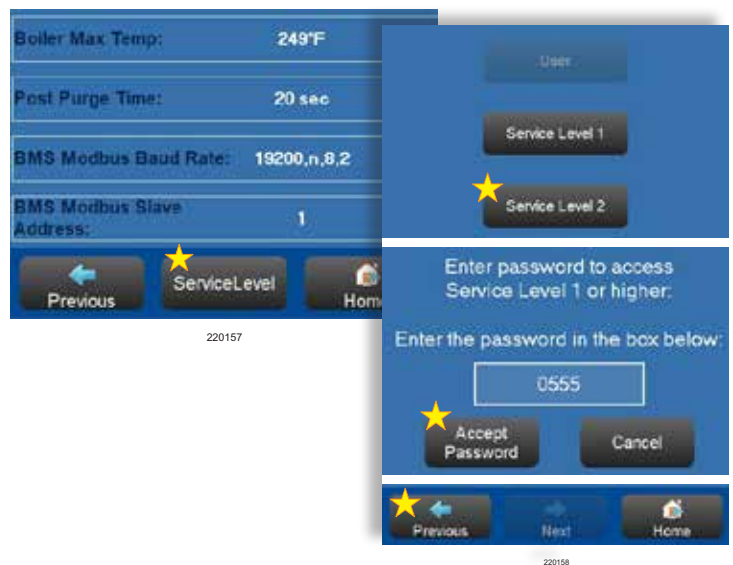

Figure 58 Modify Min and Ignition Fan Speeds



Control Setup and Operation, continued

High Altitude Fan Speed Setup, continued

5. Once the fan speeds are adjusted, there are certain, critical parameters that require parameter adjustments to the controller. These parameter changes will require a verification confirmation process.
 - a. When the parameter change is made, a red alert box will appear indicating a verification confirmation is required.
 - b. Press <Reset Controller> and answer the pop-up question.
 - c. Press <Home> and <Settings>, respectively.
 - d. Next, press <Verification> on the “All Parameters” screen.
 - e. Follow the verification process steps shown in the figures on this page.
6. With the verification process completed, the boiler is ready for operation at high altitude.

Figure 59 Safety verification process

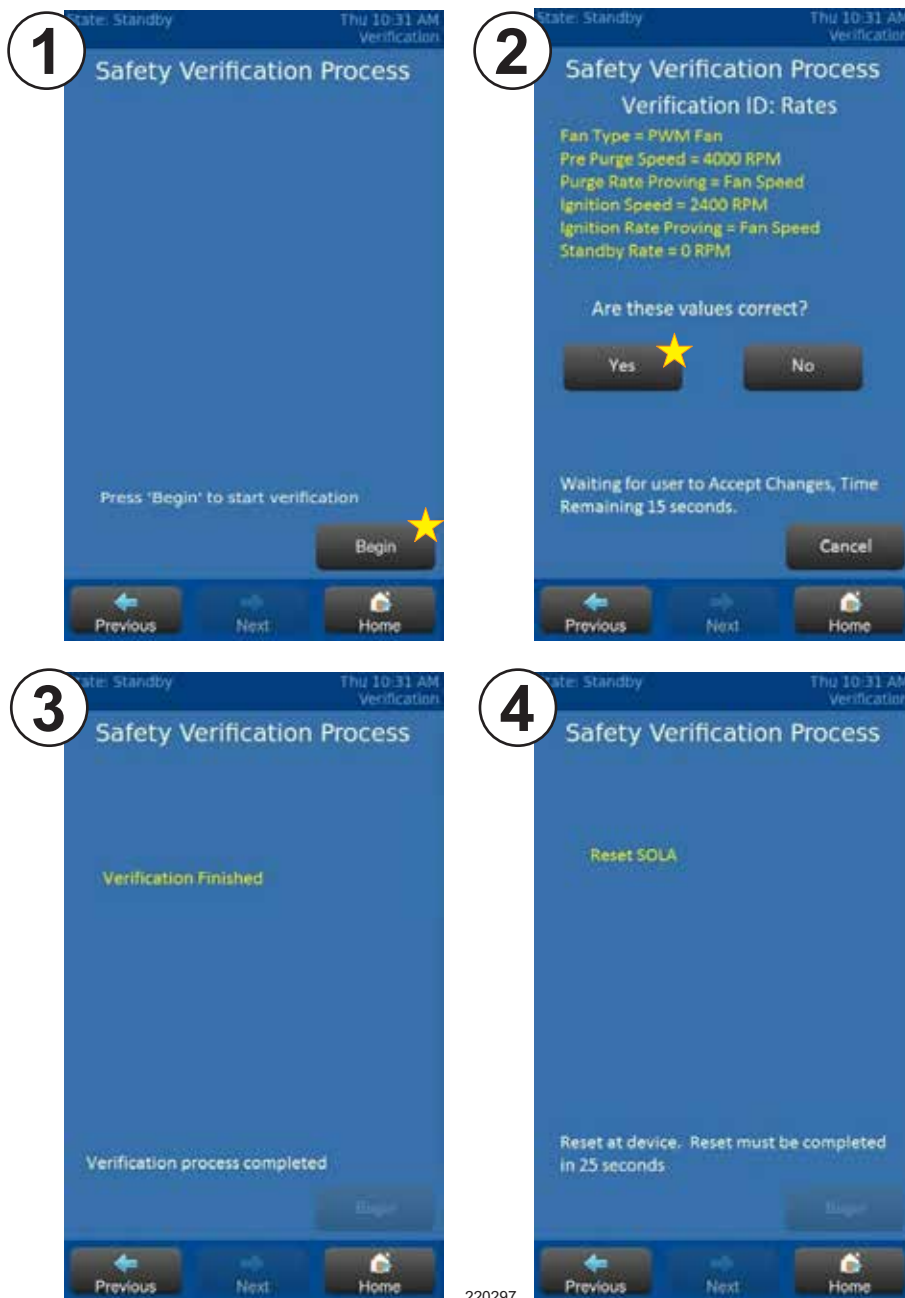

Control Panel

Once the boiler has been installed according to this manual, it is necessary to open the front door of the boiler in order to access the power (on/off) switch. The switch is located in the upper left-hand corner of the control panel as shown in Figure 60.

⚠ WARNING

Do not use the boiler if any part has been under water. Immediately call a qualified service technician to inspect the boiler and replace any part of the control system and any gas control that has been under water. Failure to comply can cause electrocution, which can result in severe personal injury or death.

⚠ WARNING

If overheating occurs, or the gas supply fails to shut off, do not turn off or disconnect the electrical supply to the pump. Shut off the gas supply at a location external to the boiler. Failure to comply can result in severe personal injury, death, or substantial property damage.

IMPORTANT

The on/off switch only interrupts power to the control system. To fully remove power to the boiler, use the external disconnect.

Touchscreen Interface

Once the power switch is in the ON position, the SVF boiler can be programmed and operated with the touchscreen interface located on the front door. See Figure 61. A clear plastic cover protects the touchscreen, which can be opened by pinching the clasp and swinging open to the left.

Factory Tests

Safe lighting and other performance criteria were met with the gas manifold and control assembly provided on this boiler. The boiler underwent factory testing specified in ANSI Z21.13/CSA 4.9, latest editions. See the factory fire test label on the back of the boiler.

Figure 60 Control panel and power switch location

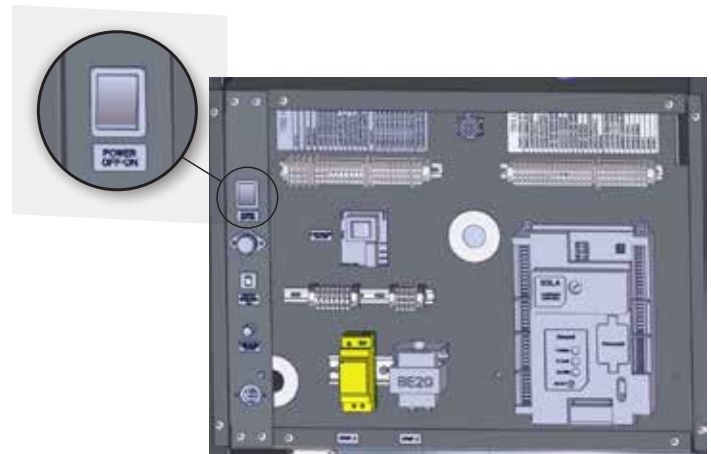

220051

Figure 61 Protective plastic cover over touchscreen



220052

Control Setup and Operation, continued

Sequence of Operations

⚠ WARNING

If any manual reset limit device trips, DO NOT reset without determining and correcting the cause. Never attempt to bypass a safety limit device. Attempting to operate a boiler without diagnosing the cause of failure can cause unsafe operation, which can result in severe personal injury, death, or substantial property damage.

Manual reset limits include flame safeguard, high or low gas pressure, high temperature limit, stack temperature, and low water level.

1. When the boiler on/off switch is turned on, power is provided through over-current protection to the boiler control and the combustion blower. This protection is provided with a fuse, circuit breaker, or both.
2. When the outlet water temperature drops below CH SETPOINT minus CH DIFFERENTIAL ON, a heat request is generated.
3. Provided all interlocks are made, and the remote enable signal is active (if installed), the boiler will attempt to start.

IMPORTANT

Once the boiler begins the ignition sequence, the firing sequence will continue until main flame is reached, regardless of heat request. The sequence can be interrupted by turning the power switch to the OFF position.

4. The control checks to make sure the air pressure switch is open, indicating there is no airflow through the boiler. The combustion blower is then driven towards the pre-start fan speed. When the air pressure switch closes, the PRE PURGE TIME timer is started. Once the timer expires, the blower is driven to the ignition speed.

Figure 62 Ignition sequencing timing

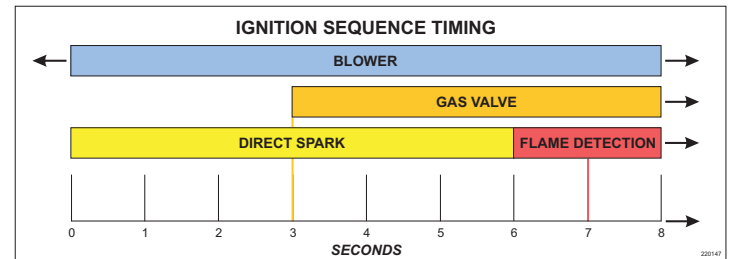

5. A trial for ignition begins. The sequence of events is illustrated in Figure 62. A valid flame signal must be detected within four seconds after the gas valves open (total elapsed time is seven seconds).
6. After a successful ignition, the fan is driven to low fire and the CH LOW FIRE HOLD TIME timer is started. Once the timer expires, the boiler is released to modulation.
7. The control modulates the firing rate between low and high fire to maintain the desired water temperature.
8. The burner will continue firing until the outlet water temperature exceeds CH SETPOINT plus CH DIFFERENTIAL OFF. At this temperature, the gas valves are closed. The combustion air fan continues to run until the POST PURGE TIME timer has expired.
9. When the outlet water temperature is reduced by the load on the system, a heat request is generated. The operating sequence will recycle to Step 3.

Startup - Fill the System

Clean the System

NOTICE

The system must be thoroughly flushed, without the boiler connected, to remove sediment. The high-efficiency heat exchanger can be damaged by buildup or corrosion due to sediment, resulting in substantial property damage.

1. If necessary, use an approved chemical cleaning agent. Follow the manufacturer's guidelines for cleaning procedures.
 - a. A list of approved cleaning products is available at www.weil-mclain.com.
 - b. See the Parts section starting on [page 111](#) for Weil-McLain part numbers to obtain cleaning agents through a WM Technologies distributor.
2. For zoned systems, flush each zone separately through a purge valve.
 - a. If purge valves and isolation valves are not already installed, install them to properly clean the system.
3. Flush the system until water runs clean. Ensure that all piping is free of sediment.

NOTICE

DO NOT use petroleum-based cleaning or sealing compounds in the boiler system. Damage to elastomer seals and gaskets could occur, resulting in substantial property damage.

NOTICE

Install a strainer or other mechanical separator device if necessary to ensure sediment will not enter the boiler.

Water Chemistry

Water pH between 7.0 and 8.5

1. Maintain boiler water pH between 7.0 and 8.5. Test the water with litmus paper, or have it chemically analyzed by a water treatment company.
2. If pH differs from above, consult a local water treatment company for treatment needed.
3. Softened water may be used to fill boiler provided that Sentinel X100 is also added to the system at the proper dosage and properly maintained. Softened water must NOT be used without Sentinel X100 as boiler corrosion may occur.

Hardness must be less than 7 grains

Consult local water treatment companies for unusually hard water areas above 7 grains hardness.

Chlorine concentration must be less than 150 ppm

- Filling the system with chlorinated fresh water should be acceptable since the chlorine levels in drinking water are typically less than 5 ppm.
- Do not use the boiler to directly heat swimming pools or spa water.
- Do not fill boiler or operate with water containing chlorine in excess of 150 ppm.

NOTICE

Before filling the boiler and system with water, verify the water chemistry complies with these instructions. Verify that the water chemistry meets the limitations and requirements of all other equipment in the system. Failure to comply can result in boiler failure or unreliable operation.

Startup - Fill the System, continued

Freeze Protection

⚠ WARNING

Failure to comply with these guidelines can result in severe personal injury, death, or substantial property damage.

Never use automotive or standard glycol antifreeze, even glycol made for hydronic systems. Use only freeze-prevention fluids recommended by WM Technologies for applications in SVF boiler systems. Thoroughly flush any system that has used glycol before installing the new SVF boiler.

Do not exceed 50% antifreeze by volume. Antifreeze is more sluggish than water, and can interfere with heat transfer. Sludge can develop in the boiler with antifreeze concentrations higher than 50%, potentially causing damage to the heat exchanger.

Always drain and flush the system thoroughly before filling with antifreeze. Sludge, iron, oxide

deposits, and other sediment in the system inhibit flow and can cause rapid breakdown of inhibitors.

Install a water meter or monitor water make-up when using freeze protection fluid with automatic fill. Antifreeze may leak before the water begins to leak, causing concentration to drop and reducing the freeze protection level.

Test antifreeze concentration at least annually. If concentration is low, either add antifreeze to the current mixture, or drain the system and refill with the correct mixture. Running the system with low antifreeze concentration can result in substantial property damage.

Review the material safety data sheet (MSDS) with the boiler owner for the fluid used. Leave a copy with the owner for reference. The MSDS contains information on potential hazards and first aid procedures for exposure or ingestion.

Antifreeze

A list of approved antifreeze products is available at www.weil-mclain.com. See the Parts section starting on [page 111](#) for Weil-McLain part numbers to obtain antifreeze through a WM Technologies distributor. Read all warnings above before using any freeze protection in the boiler system.

Use the correct amount of antifreeze:

1. Determine the freezing temperature needed to protect against the lowest likely temperature the system water will encounter.
2. Find the antifreeze percentage (concentration by volume) needed for the freezing temperature from the antifreeze manufacturer's data on the antifreeze container.
3. Calculate the total volume (gallons) of all system piping and components, including the expansion tank and boiler. Boiler water content is listed in [Table 19, page 121](#).
4. The gallons of antifreeze required equals the total water volume multiplied by the antifreeze percentage required.
5. Verify that the water flow rate and temperature rise with antifreeze is in line with [Table 5, page 21](#) requirements.

Fill and Test the Water System

1. Fill the system only after ensuring the water meets the requirements of this manual.
2. Close the manual and automatic air vents and boiler drain valve.
3. Fill to correct system pressure. Correct pressure will vary with each application.
 - a. Pressure will rise when the boiler is turned on and system water temperature increases.
 - b. Operating pressure should be no higher than 80% of the relief valve setting for most systems.
4. At initial fill and during boiler startup and testing, thoroughly check the system and repair all leaks.

NOTICE

Eliminate all system leaks. Continual fresh make-up water will reduce boiler life. Minerals can build up, reducing heat transfer, overheating the heat exchanger, and causing heat exchanger failure.

5. After the system has been filled and leak tested, verify that the water pH and chloride concentrations are acceptable.
6. Verify antifreeze concentration, when used.

Recommended Inhibitor

Adding Sentinel X100 to the boiler system will prevent damage to the heat exchanger. See [page 111](#) for ordering information.

1. After filling the system as directed in these instructions, use a caulking gun to inject the X100 inhibitor concentrate into the system. Alternatively, fill the system with X100 in its liquid form, following the instructions on the tube or container.
2. After adding the inhibitor to the system, allow time for the water to circulate and mix. Check the inhibitor level. Add additional inhibitor if necessary.
3. See manufacturer instructions or www.weil-mclain.com to determine how much inhibitor to use.

IMPORTANT

Check inhibitor level at least annually as inhibitor levels may change over time. Add an inhibitor as needed to bring to an acceptable level. Use an inhibitor test kit to verify.

Purge Air from the Water System

1. Connect a hose to the purge valve. See purge/drain valves shown in piping diagrams beginning on [page 22](#). Route the hose to an area where water can drain and be seen.
2. Close the boiler or system isolation valve between the purge valve and fill connection to the system.
3. Close the zone isolation valves.
4. Open the quick-fill valve on the cold water make-up line.
5. Open the purge valve.
6. Open the isolation valves one zone at a time. Allow water to run through, pushing out air until no air flow is present. Close the isolation valves and proceed to the next zone. Repeat until all zones are purged.
7. Close the quick-fill water valve and purge valve. Remove the hose. Open all isolation valves. Watch that the system pressure rises to correct cold-fill pressure.
8. Operate and purge the system to eliminate trapped air.

System without purge valves:

1. If purge valves are not installed, open manual air vents in the system one at a time, beginning with the lowest floor. Close the vent when water comes out.
2. Repeat with the remaining vents.
3. Refill the system to the correct pressure.

System with a diaphragm-type or bladder-type expansion tank:

1. Open the automatic air vent one turn. These vents are used on diaphragm-type or bladder-type expansion tanks only.
2. Refill the system to the correct pressure.

Check Concentrations Annually

1. Test the pH of a sample of system water at least annually. The pH of the water mixture must be between 7.0 and 8.5. Alternately, use the Sentinel inhibitor test kit to check concentration.
 - a. If pH is outside this range, or the inhibitor test kit indicates low level, the inhibitor level may not be sufficient to prevent corrosion.
2. Test antifreeze concentration. Follow instructions on [page 80](#) to determine the amount of antifreeze.
3. Check the inhibitor level after adjustments are made.

Startup - Final Checks

Check for Gas Leaks

Before starting the boiler, and during initial operation, use a leak detector or smell around the boiler and floor for gas odorant or any unusual odor. Remove the boiler jacket door and smell the interior of the boiler jacket.

⚠WARNING

DO NOT proceed with startup if there is any indication of a gas leak. Repair any leak at once. Starting the boiler up when there is a gas leak could cause an explosion, which can result in severe personal injury, death, or substantial property damage.

Propane Boilers:

For boilers using propane, verify it has been converted for propane. See [page 16](#) for conversion instructions.

The propane supplier mixes an odorant with the propane to make its presence detectable. This odorant can fade in some instances, and the gas may no longer have an odor. Before startup, and periodically thereafter, have the propane supplier verify the correct odorant level in the gas.

Check Thermostat Circuits

1. Disconnect the two external wires connected to the boiler thermostat terminals. See Sections H and L on pages [69](#) and [70](#) for terminal locations. See the SVF Advanced Manual (part number 550-100-292) for information on how to perform this through the control.
2. Connect a voltmeter across these two incoming wires. Close each thermostat, zone valve, and relay in the external circuit one at a time. Check the voltmeter reading across the incoming wires.

NOTICE

There should NEVER be a voltage reading across the thermostat circuit wiring. If a voltage does occur under any condition, check and correct the external wiring. Applying voltage across the thermostat terminals will damage the control.

Figure 63 Test port cap removal

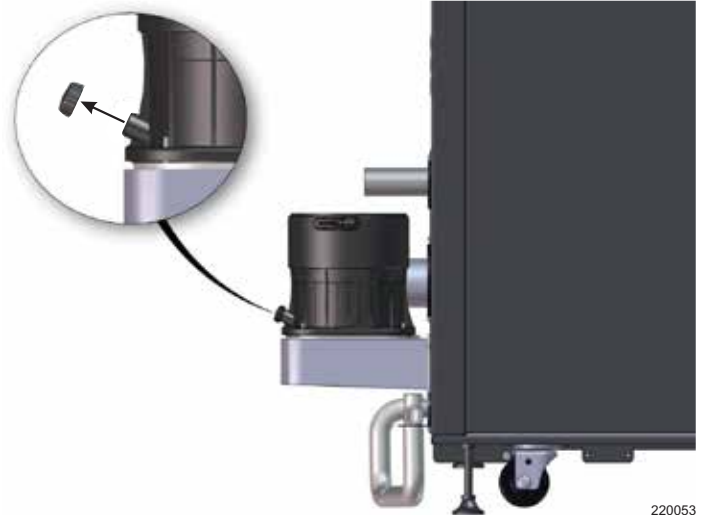

220053

3. Once the external thermostats circuit wiring is checked, and corrected if necessary, reconnect the external thermostat circuit wires. Allow the boiler to cycle.

Inspect and Fill the Condensate System

Inspect the condensate drain line, PVC fittings, and trap. See [page 55](#) for component locations.

Fill the condensate trap with water:

1. Remove the test port cap from the vent adapter. See Figure 63.
2. Pour one cup full of clean water into the test port.
3. Ensure the condensate trap is filled with water.
4. Install the test port cap onto the vent adapter.

⚠WARNING

The condensate trap must be filled with water during boiler operation at all times to avoid flue gas emission from the condensate drain line. Failure to fill the trap can result in severe personal injury or death.

Figure 64 Operating instructions, warning

FOR YOUR SAFETY READ BEFORE OPERATING

WARNING

If you do not follow these instructions exactly, a fire or explosion may result causing property damage, personal injury or loss of life.

A. This appliance does not have a pilot. It is equipped with an ignition device which automatically lights the burner. Do not try to light the burner by hand.

B. Before OPERATING, smell all around the appliance area for gas. Be sure to smell next to the floor because some gas is heavier than air and will settle on the floor. See below.

C. Use only your hand to turn the gas valve handle. Never use tools. If the handle will not turn by hand, don't try to repair it, call a qualified service technician. Force or attempted repair may result in a fire or explosion.

D. Do not use this appliance if any part has been under water. Immediately call a qualified service technician to inspect the appliance and to replace any part of the control system and any gas control, which has been under water.

WHAT TO DO IF YOU SMELL GAS

- Do not try to light any appliance.
- Do not touch any electric switch; do not use any phone in your building.

- Immediately call your gas supplier from a neighbor's phone. Follow the gas supplier's instructions.
- If you cannot reach your gas supplier, call the fire department.

4

OPERATING INSTRUCTIONS

1. Stop! Read the safety information at left on this label. This appliance is equipped with an ignition device which automatically lights the burner. Do not try to light the burner by hand.
2. Set room thermostat(s) to lowest setting. Verify external manual gas cock is open (valve handle parallel to gas piping).
3. Turn OFF all electrical power to the appliance.
4. Remove boiler access door.
5. Turn boiler manual gas valve handle counterclockwise to open gas supply.
6. Wait five (5) minutes to clear out any gas. Then smell for gas, including near the floor. If you smell gas, STOP! Follow "B" in the safety information to the left. If you don't smell gas, go to the next step.
7. Turn ON all electrical power to the appliance.
8. Set thermostat(s) to desired setting.
9. The display will show symbols and text describing the status of the boiler as it proceeds through its operating sequence.
10. If the appliance will not operate when there is a call for heat and piping is not hot, follow the instructions "To Turn Off Gas To Appliance" below and call your service technician or gas supplier.

**Gas valve
CLOSED**

**Gas valve
OPEN**

11. Reinstall boiler access door. Make sure panel is seated firmly in place.

TO TURN OFF GAS TO THE APPLIANCE

1. Set room thermostats to lowest setting.
2. Turn OFF all electrical power to the appliance.

3. Close external manual gas cock (valve handle perpendicular to gas piping). Remove boiler access door. Turn boiler manual gas valve handle clockwise to close gas supply.
4. Reinstall boiler access door.

550-101-262 (0218)

Startup - Final Checks, continued

Inspect the Pressure Switch Hoses

Inspect all pressure switch sense hoses and verify correct installation. See Figure 65 and Figure 66. Replace the hoses if necessary.

NOTICE

The pressure switch sense lines must be in good condition and firmly attached to the correct locations. Incorrect placement or disconnected sense lines can result in unreliable boiler operation.

Final Checks Before Starting the Boiler

- ❑ Read the instructions to adjust and set up the control module. Verify that all settings have been made correctly.
- ❑ Verify that the boiler and system are full of water and all system components are correctly set for operation.
- ❑ Vent any remaining air from the system using manual vents. Air in the system will interfere with circulation and cause heat distribution issues and noise.
- ❑ Check system piping for leaks. If any leaks are found, shut down the boiler and repair immediately.
- ❑ Fill condensate trap with water. See [page 82](#) for the procedure.
- ❑ Verify electrical connections are correct and securely attached.
- ❑ Inspect vent and air piping in direct vent systems for signs of deterioration from corrosion, physical damage, or sagging. Verify vent and air piping is intact and correctly installed per this manual.

Figure 65 Pressure switch tube locations

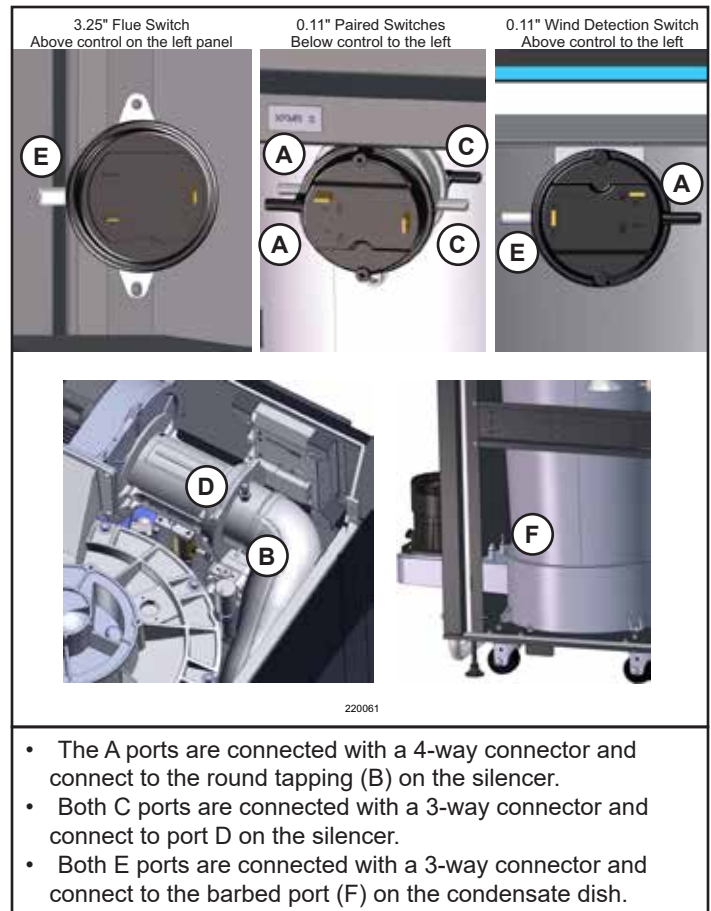

⚠ WARNING

Venting system must be sealed gas-tight to prevent flue gas spillage and carbon monoxide emissions, which can result in severe personal injury or death.

Figure 66 Pressure switch diagram

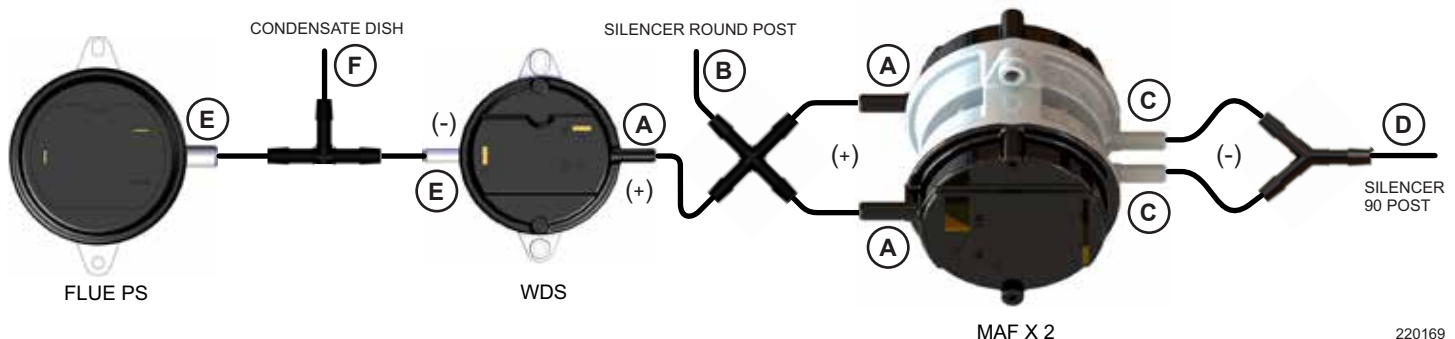

Startup Procedure

Starting the Boiler

1. Apply power to the boiler via the service switch.
2. Follow the operating instructions on [page 83](#).
3. If this is the first time powering the boiler, refer to the Control section starting on [page 73](#).
4. Complete the setup WIZARD. The WIZARD is recommended for all boilers because it guides the user through setups for multiple applications.
5. Ensure all connected sensors are detected and the correct boiler model is identified. If not, determine the cause and correct before proceeding.
6. Check water, vent, air and gas piping again for leaks. If any leaks are found, shut down the boiler and repair immediately.

Troubleshooting Startup Issues

1. Check for loose connections, a blown fuse, or if the service switch is in the off position.
2. Is gas turned on at the meter and at the boiler?
3. Are control settings correct for the application?
4. Is the warm weather shutdown activated?
5. Are thermostats set below room temperature?
6. Are external limit controls open (if used)? Is the boiler water temperature above 200°F?
7. Are the closure switch contacts open?
8. Is incoming gas pressure within the limits of the minimum and maximum values given on [page 57](#)?
9. If none of the above corrects the issue, refer to the Troubleshooting section starting on [page 109](#).

Check Flame and Combustion

1. Ensure that all load devices, such as control valves, radiators, and air handling units, are in operation to prevent the boiler from cycling off during adjustment. The load devices must be able to shed or dump the heat created by the boiler.
2. To adjust and tune combustion, use the Manual Control Firing Rate mode.
 - a. Touch the INFO button in the lower left corner of the display screen.
 - b. Press SERVICE in the lower left.
 - c. Next, touch Press to Activate Manual Control to open the Manual Control Firing Rate mode.
3. Initiate a call for heat on a thermostat input.

Table 13 Acceptable combustion values

Fuel	High Fire		Low Fire	
	% CO ₂	CO ppm	% CO ₂	CO ppm
NG	9.25 ± 0.5	< 100	8.75 ± 0.5	< 50
LP	10.50 ± 0.5	< 150	10.00 ± 0.5	< 50

• Values above are with the boiler front door removed. Values will increase about 0.2% once the door is reinstalled.
 • The low fire CO₂ must be lower than the high fire CO₂ values.
 • Values above are for altitudes up to 2,000 ft.. For higher altitudes, CO₂ may be slightly lower and CO slightly higher. Refer to [Table 14, page 107](#) for more information.
 • Reinstall the boiler door after completing service.

High Fire Check:

4. Make sure the maximum firing rate is set to the maximum given in [Table 14, page 107](#). Adjust as necessary.
5. Once the boiler cycles on, use the UP arrow or the slider to force the boiler to operate at 100% (high fire).
6. Look at the flame through the flame inspection window. The high fire flame should be blue and stable. The burner surface should be covered with orange dots.
7. Remove the test port cap from the vent flue adapter. Insert a combustion test probe. For test port location, see [Figure 63, page 82](#).
8. Test for CO₂ (or O₂) and CO. The CO₂ values must comply with Table 13. If results are acceptable, proceed to the next step. If not, follow the instructions under the Gas Valve Adjustment section starting on [page 86](#) to set the positions of the throttle and offset regulating screws.
9. To check the natural gas input (as needed):
 - a. Turn off other appliances.
 - b. Operate the boiler for 10 minutes.
 - c. At the natural gas meter, measure time in seconds required to use one cubic foot of gas.
 - d. Calculate the gas input:

$$\frac{3600 \times 1000}{\text{number of seconds from step c}} = \text{Btuh}$$

- e. Btuh calculated should approximate input rating on boiler rating label.



Startup Procedure, continued

Check Flame and Combustion, continued

Low Fire Check:

10. Use the control display to navigate to Manual Control Firing Rate and force the rate to 0% (low fire). See previous steps for navigation instructions.
11. Look at the flame through the flame inspection window. The low fire flame should be stable, with a uniform orange color, and evenly distributed over the burner surface.
12. Repeat the combustion test as instructed in the previous steps.
13. Use the control display to exit the Manual Control Firing Rate menu and revert back to normal operation.
14. Reinstall the vent flue cap and ensure it is sealed.

WARNING

The vent flue cap must be installed to prevent flue gas spillage into the boiler enclosure. Failure to comply can result in severe personal injury, death, or substantial property damage.

Gas Valve Adjustment

IMPORTANT

Adjust the throttle or offset screw only as needed to meet the combustion values given in [Table 13, page 85](#). Do not attempt to adjust the throttle screw at low fire. Confirmation of the correct low fire RPM must be made before adjusting the offset regulating screw.

CAUTION

Adjust the throttle and offset screws in small increments.

WARNING

DO NOT attempt to adjust the throttle or offset screws unless done by a qualified technician with calibrated combustion test instruments. Failure to comply can result in severe personal injury, death, or substantial property damage.

Figure 67 Throttle and offset regulating screws



1. Throttle screw adjustment is only necessary if specified elsewhere in this manual, or if combustion tests indicate the need. See Check Flame and Combustion on [page 85](#) for testing.
2. Boiler behavior could indicate a need to check combustion values at high fire, such as:
 - Difficulty igniting
 - Poor flame stability at low fire
 - Combustion noise
 - High carbon monoxide values
3. Combustion readings must be taken at both high fire and low fire. See Figure 67 for screw locations.
4. If gas valve adjustment does not correct the issue, shut down the boiler and contact your local WM Technologies representative.
5. For a coarse throttle adjustment on the gas valve, carefully tighten the throttle screw until it bottoms out.
 - a. For natural gas boilers, back the throttle screw out 2 and 1/4 turns after tightening.
 - b. For propane boilers, back the throttle screw out 1 and 3/4 turns after tightening.

Gas Valve Adjustment, continued

High fire adjustment:

IMPORTANT

Adjust only the throttle screw for high fire.

6. Make sure the MAX RATE is set to 100% and the MIN RATE is set to 10% for the PRIORITY being tested.
7. Navigate to the Manual Control Firing Rate menu. See Check Flame and Combustion on [page 85](#) for instructions.
8. Force the boiler to 100% (high fire). Ensure the blower speed has achieved the RPM listed in [Table 14, page 107](#).
9. Allow adequate time for the combustion analyzer to stabilize. Take CO₂ and CO readings. Refer to [Table 13, page 85](#) for acceptable combustion values.
10. If the CO₂ is high or low, remove the top cover of the gas valve and adjust the input.
 - a. If the CO₂ is high, turn the throttle screw CLOCKWISE in small increments with a 4 mm Allen wrench to *decrease* the input.
 - b. If the CO₂ is low, turn the throttle screw COUNTERCLOCKWISE in small increments to *increase* the input.
11. Allow the boiler to stabilize before taking another reading. This typically takes 20-30 seconds.
12. Continue until the desired CO₂ value is achieved.
13. Confirm that the CO is within limits.
14. Reinstall the top cover on the gas valve.

Low fire adjustment:

IMPORTANT

Adjust only the offset regulating screw for low fire.

15. Adjust the boiler to 0% (minimum output) and allow the boiler to stabilize. Confirm the RPM value during operation. See [Table 14, page 107](#).
16. Remove the T40 Torx head cap for offset screw adjustment. See [Figure 67, page 86](#).
 - a. If the CO₂ is high, turn the offset regulation screw COUNTERCLOCKWISE in *very small* increments to lower the input.
 - b. If the CO₂ is Low, turn the offset regulating screw CLOCKWISE to increase the input.
17. Allow the boiler to stabilize before taking another

reading. This may take a few minutes.

18. Continue until the desired CO₂ value is achieved.
19. Confirm that the CO is within the limits in [Table 13, page 85](#).
20. Reinstall the T40 Torx head cap when adjustment is complete.

Maximum and Minimum Final Check

1. Turn the boiler off, then restart it and put into test mode at high fire. Ensure the CO₂ setting level has remained unchanged, and confirm that CO is within limits.
2. Reduce to low fire and check the minimum rate output. Ensure the CO₂ setting level has remained unchanged, and confirm that CO is within limits.
3. Repeat the steps under high fire adjustment or low fire adjustment if necessary.
4. If any assistance is needed during the set up procedure, and the issue cannot be addressed with the information provided in this manual, contact WM Technologies Technical Services.

Check Ignition System Safety Shutoff Device

1. After the boiler has been installed, turn off the boiler.
2. Shut off the manual gas valve, located downstream of the gas valve, to stop flow of fuel to the boiler.
3. Turn on the boiler. The ignition sequence will start, but the burner will not light.
4. The boiler will lockout after some time. The display screen will turn red and the control will be a solid red alarm; this means the boiler tried to ignite without success. There is one retry before lockout, which is in accordance with ASME CSD-1, latest edition. The ignition system safety device is working properly when the lockout performs as indicated in this step.
5. Clear the lockout condition by selecting Reset Control in the red lockout box.
6. Open the manual gas valve to resume fuel supply to the boiler.

Startup Procedure, continued

Check the System for Leaks

⚠WARNING

The system must be sealed gas-tight to prevent flue gas spillage and carbon monoxide emissions. Gas spillage and emissions can result in severe personal injury or death.

1. Operate the boiler on high fire.
2. Move an inspection mirror around all heat exchanger cover plate joints at the top of the boiler to check for leaks.
3. Inspect the joints between the condensate dish, vent adapter, and vent pipe.
4. Check for gas-tight seals at every connection and seam of air and vent piping.
5. A leak appears as vapor on the surface of the mirror. In addition, look for signs of weepage or other indications that there may be leakage.
6. If there is any indication of a leak at any joint, shut down the boiler immediately.
 - a. Tighten the retaining screws or nuts if possible. Do not over tighten.
 - b. If tightening the screws or nuts does not correct the issue, disassemble the components where the leak appeared. Use the procedures given in the Maintenance section, starting on [page 91](#).
 - c. When disassembling components, inspect gaskets to see if there is any damage. Replace damaged gaskets.

Contact WM Technologies Technical Services if the problem cannot be address with the information provided in this manual.

Gas Valve Leakage Testing

Refer to the gas valve manufacturer's instructions for the procedure to test the valve. Use the following procedure to turn the two solenoid valves on the gas valve on one at a time.

1. Turn off power to the boiler.
2. Obtain the gas valve test harness, located in the envelope assembly included with the boiler.
3. Disconnect the gas valve electrical harness.
4. Plug in the gas valve test harness between the gas valve and the gas valve electrical harness.

5. Ensure both test harness rocker switches are in the ON position.

⚠WARNING

DO NOT connect a manometer to the manual or automatic gas valve. The high vacuum from the blower could pull fluid into the gas line, which could damage the gas valves. Failure to comply can result in severe personal injury, death, or substantial property damage.

6. Turn on power to the boiler.
7. Give the boiler a call for heat.
8. Verify that the boiler operated through a normal ignition sequence.
9. Operate each of the gas valve solenoids individually.
 - a. Turn the test harness rocker switches to OFF.
 - b. Turn on one of the rocker switches.
 - c. Provide a call for heat.
 - d. When the gas valve is energized, only one indicator should light, V1 or V2. See [Figure 67, page 86](#).
 - e. Use a piece of tape to label this rocker switch as V1 or V2, depending on which indicator lit up.
 - f. Label the other rocker switch with the name of the other indicator light (V1 or V2).
 - g. Power the boiler on and off. Use the rocker switches to operate solenoid V1 or V2 independently as called for in the gas valve manufacturer's leak test instructions.
10. Once testing is complete, turn power off to the boiler.
11. Disconnect the gas valve test harness, and place it back into the envelope assembly for future use.
12. Reconnect the gas valve electrical harness.

IMPORTANT

The gas valve electrical harness must be reconnected to return the boiler to normal function.

13. Turn on power to the boiler.
14. Operate the boiler through an ignition cycle to ensure proper operation.

Verification Check List

- Verified that the control is programmed correctly?
- Verified that the boiler and heat distribution units are filled with water?
- Verified water chemistry per [page 79](#)?
- Automatic vents opened one full turn (if used)?
- Air purged from the system?
- Filled the condensate trap with water?
- Thermostat circuit wiring checked to ensure there are no stray voltages?
- Followed the operating instructions in [Figure 64, page 83](#)?
- Burner flame and combustion verified per [pages 85-86](#)?
- Verified control operation for space heating and DHW (if used) per this manual?
- Tested additional field-installed controls? Verified these controls cause automatic reset or manual lockout as desired?
- Set additional field-installed limit controls to system temperature requirements?
- Adjusted balancing valves and controls to provide the correct temperature to the system per system design?
- Verified that the thermostat heat anticipator is set properly (if available)? See [page 65](#) for requirements.
- For multiple zones, adjusted for correct flow in each zone?
- Cycled boiler with thermostat and DHW aquastat (if installed)? Raised to highest setting and verified the boiler goes through normal startup cycle? Lowered to lowest setting and verified the boiler turns off?
- Measured natural gas input?
- Checked incoming gas pressure as specified on [page 57](#)?
- Observed several operating cycles for proper operation?
- Set room thermostat to desired room temperature?
- If installed, set DHW aquastat to desired DHW storage temperature?
- Reviewed all instructions shipped with this boiler with the owner or maintenance person?
- Filled in the Installation and Service Certificate on [page 124](#)?
- Filled out the warranty registration card and sent it to WM Technologies?
- Return all instructions to the envelope, and either give it to the owner, or place it inside the boiler housing. Instructions must be available for all service and adjustment of the boiler.

This page intentionally left blank

SECTION 5

Maintenance

This section is intended to provide maintenance instructions and timing for the boiler.

Section Contents

Maintenance - General	91
Annual Inspection	92
Annual Startup	95

Maintenance - General

⚠WARNING

Turn off power to the boiler before any service operation except as noted otherwise in this manual. Failure to turn off electrical power can cause electrical shock, which can result in severe personal injury or death.

Handling Ceramic Fiber Materials

⚠WARNING

The cover plate components, refractory insulation, and gaskets contain ceramic fiber materials that have been identified as carcinogenic, or possibly carcinogenic, to humans. Avoid breathing in dust. Avoid contact with skin and eyes. Wear long-sleeve, loose-fitting clothing, gloves, and eye protection when working on the boiler. Use a NIOSH certified dust respirator (N95). Failure to comply can result in severe personal injury or death.

Ceramic fibers can be converted to cristobalite in very high temperature applications. The international Agency for Research on Cancer (IARC) has concluded, "Crystalline silica inhaled in the form of quartz or cristobalite from occupational sources is carcinogenic to humans (Group 1)."

Use of an N95 respirator is based on the OSHA requirements for cristobalite at the time this document was written. Other types of respirators may be needed depending on the job site conditions.

Preventative measures include the following:

- Avoid breathing in dust.
- Wear long-sleeved, loose fitting clothing, gloves, and eye protection.
- Use an N95 respirator
- Handle cover plate components, refractory insulation, and gaskets carefully.
- If replacement is necessary, remove the parts and insulation from the boiler and place into a plastic bag for disposal.
- Wash potentially contaminated clothes separately from other clothing. Rinse the clothes washer thoroughly afterwards.

Current NIOSH recommendations can be found on the NIOSH website at www.cdc.gov/niosh/homepage.html. NIOSH approved respirators, manufacturers, and phone numbers are also listed on this website.

NIOSH stated First Aid for contact or irritation:

- Eyes: Irrigate immediately
- Breathing: Fresh air

Perform Startup and Checkout

After any maintenance procedure, verify operation of the boiler. Removing and reinstalling components can change boiler behavior. Follow the complete procedure for boiler and system startup, beginning on [page 79](#).

⚠WARNING

Wiring errors can cause improper and dangerous operation. Label all wires to ensure proper connection. Never jumper (bypass) any device except for momentary testing. Failure to comply can result in severe personal injury, death, or substantial property damage.



Annual Inspection

First-Year Special Inspection

Obtain a Boiler Annual Maintenance Kit (part number 384-000-379) before attempting the first-year inspection to ensure all needed parts are available. This kit includes a heat exchanger cover plate gasket, burner gasket, new ignition electrode, igniter gasket, and a flame sense rod with gasket. See the Parts section starting on [page 111](#) for ordering information. These parts must be on hand when performing the first-year inspection in the event that replacement must be completed.

⚠ WARNING

Failure to replace the items listed above when needed can result in severe personal injury, death, or substantial property damage.

⚠ WARNING

Do not use compressed air to clean the burner. Failure to comply can result in severe personal injury, death, or substantial property damage.

1. No later than 12 months after the boiler is installed, perform a first-year inspection of the boiler. The inspection should include the following specific instructions, in addition to routine annual start-up procedures.
 - a. Inspect the heat exchanger and clean if necessary. See [page 99](#) for access and cleaning procedures.
 - b. Inspect the cover plate insulation and gasket. Replace if not in good condition.
 - c. Remove and clean the burner thoroughly with one of two methods:
 - Vacuum the burner. Be careful not to rub or scrape the fiber mesh.
 - Flush the burner with water. Rinse the burner down. Allow time for the burner to dry completely before reinstalling.

- d. Make sure there is no blockage or accumulation of debris in the burner or burner ports. Replace the burner if necessary.
 - e. Check the burner mesh for tightness.
 - f. Make sure to follow the inspection procedure given on [page 88](#).
 - g. Disconnect the condensate trap and drain lines; inspect, then flush thoroughly. Reinstall and refill the trap per [pages 55](#) and [82](#).
2. Determine any follow-up maintenances and service needs based on the condition of the heat exchanger and condensate lines.
 - a. If the heat exchanger shows substantial fouling, or if the condensate lines show accumulation of sediment, schedule a follow-up service call to perform the first-year inspection again. This service call should be sooner than the normal 12 months between inspections.
 - b. Heavy fouling of the exchanger or condensate lines indicates possible combustion air contamination. Inspect the air intake area carefully. Remove all possible contaminants. See [page 30](#) for products to avoid.

NOTICE

Corrosion and contamination causes must be eliminated to ensure reliable operation of the boiler and system. Failure to eliminate these causes can result in substantial property damage.

5

General Information

The boiler should be inspected and started at the beginning of the heating season annually, only by a qualified service technician.

The maintenance and care of the boiler designated on [page 94](#), and explained on the following pages, must be performed to assure maximum boiler efficiency and reliability.

Inspect any issues reported by the owner and correct before proceeding.

NOTICE

Failure to service and maintain the boiler and system can result in equipment failure.

⚠ WARNING

Do not use solvents to clean any of the boiler components. The components could be damaged, causing unreliable or unsafe operation, which can result in severe personal injury, death, or substantial property damage.

⚠ WARNING

Turn off power to the boiler before any service operation except as noted otherwise in this manual. Failure to turn off electrical power can cause electrical shock, which can result in severe personal injury or death.

Inspect the Boiler Area

1. Verify the boiler area is free of any combustible materials, gasoline, and other flammable vapors and liquids.
2. Verify the air intake area is free of any contaminants listed on [page 30](#). Remove any contaminants that are present in the boiler intake air vicinity. If the contaminants cannot be removed, reinstall the air and vent lines per this manual.

Inspect the Boiler Interior and the Jacket Door Gaskets

1. Remove the jacket door and inspect the interior of the boiler.
2. Visually inspect the jacket door gaskets in front of the cabinet. Make sure all gaskets are in good condition. Replace any damaged gasket.

⚠ WARNING

Jacket door gaskets must be intact and must provide a reliable seal. Failure to comply can result in severe personal injury, death, or substantial property damage.

3. Remove the venturi air inlet silencer and clean if necessary. Reinstall the silencer.
4. Vacuum any sediment from the inside of the boiler and components. Remove any obstructions.

Inspect and Clean the Condensate Trap

1. Inspect the condensate trap. If the trap has accumulated debris, remove the trap and clean.

NOTICE

If removing and reinstalling the trap, see [page 55](#) for more information.

2. Loosen the hose clamps from the condensate trap inlet and outlet connections. Remove trap and flush as needed.
3. Ensure there are no visible cracks or damage to the trap. Make sure the inlet and outlet connections are in good condition.
4. Reinstall the condensate trap.
5. Fill the trap with fresh water by pouring into the flue adapter test port. Continue filling slowly until water begins flowing out of the condensate drain line. Make sure the trap line is unobstructed and flows freely. See [page 82](#) for more information.
6. Verify all the connections are made with no leaks to complete installation.

Inspect All Piping for Leaks

⚠ WARNING

Eliminate all system or boiler leaks. Failure to comply can result in severe personal injury, death, or substantial property damage.

Inspect all water and gas piping. Look for signs of leaking lines. Correct any issues found. See the procedure on [page 57](#) for checking gas lines.

Annual Inspection, continued

Service and Maintenance Schedules

Service Technician <i>(use this manual for instructions)</i>		Owner Maintenance <i>(see the User Manual for instructions)</i>	
Annual Start-up (also see the first-year inspection instructions)	General: <ul style="list-style-type: none"> <input type="checkbox"/> Investigate reported issues. <input type="checkbox"/> Clean the condensate trap and fill with fresh water. <input type="checkbox"/> Check for leaks (water, gas, flue, and condensate). <input type="checkbox"/> Check system water chemistry, inhibitor level, and antifreeze concentration, if used. <input type="checkbox"/> Check boiler relief valve. <input type="checkbox"/> Verify flue and air lines are in good condition and sealed tight. <input type="checkbox"/> Verify operation of the combustion air damper, if used. <input type="checkbox"/> Check system water pressure, system piping, and expansion tank. <input type="checkbox"/> Check ignition electrode and flame sense rods. Inspect, clean, and check spacings. <input type="checkbox"/> Check ignition and ground wiring. <input type="checkbox"/> Check control function and settings: <ul style="list-style-type: none"> • High gas pressure switch • Low gas pressure switch • Low water cut-off • Operating and high limits <input type="checkbox"/> Check wiring and connections. <input type="checkbox"/> Perform startup checkout and performance verification beginning with Startup, Fill the System, page 79. <input type="checkbox"/> Check high flue, min. airflow, and wind detection pressure switches per page 102. <input type="checkbox"/> Inspect flame for stability and uniformity. <input type="checkbox"/> Check the flame signal. <input type="checkbox"/> Clean the heat exchanger if flue temperature is more than 30°F above return water temperature. <input type="checkbox"/> Check the blower speed settings. 	Daily <ul style="list-style-type: none"> <input type="checkbox"/> Check the boiler area. <input type="checkbox"/> Check air openings. <input type="checkbox"/> Check pressure/temperature gauge. <input type="checkbox"/> Verify the boiler panels are securely in place. 	
	Additional actions if combustion or performance indicate the need: <ul style="list-style-type: none"> <input type="checkbox"/> Clean heat exchanger <input type="checkbox"/> Remove the burner and clean with a vacuum or water flush only. Refer to instructions and warnings on page 105. <input type="checkbox"/> Vacuum the blower. 	Monthly <ul style="list-style-type: none"> <input type="checkbox"/> Check the vent piping. <input type="checkbox"/> Check the air piping. <input type="checkbox"/> Check the relief valve. <input type="checkbox"/> Check the condensate drain system. <input type="checkbox"/> Check the air vents. 	
	Review: <ul style="list-style-type: none"> <input type="checkbox"/> Review with the owner 	Periodically <ul style="list-style-type: none"> <input type="checkbox"/> Test low water cutoff by pressing the test button. 	
		Every 6 Months <ul style="list-style-type: none"> <input type="checkbox"/> Check the boiler gas and water piping. <input type="checkbox"/> Operate the relief valve. 	
		End of Season <ul style="list-style-type: none"> <input type="checkbox"/> Shut down the boiler (unless the boiler is used for domestic water). 	

⚠ WARNING

Follow the service and maintenance procedures given throughout this manual and other literature shipped with the boiler. Failure to perform service and maintenance can cause damage to the boiler or system. Failure to follow the directions in this manual and component literature can result in severe personal injury, death, or substantial property damage.

Print or photocopy this page to keep an annual record



Annual Startup

Check Air Openings

1. Verify that combustion and ventilation air openings to the boiler room and building are open and unobstructed.
2. Check operation and wiring of automatic combustion air dampers, if used.
3. Verify the boiler vent discharge and air intake are clean and free of obstructions.

NOTICE

Failure to reinstall or repair a combustion air damper can result in nuisance shut downs or substantial property damage.

Flue Vent System and Air Piping

1. Visually inspect the entire flue gas venting system, and air piping if installed, for blockage, deterioration, or leakage.
2. Inspect both 3-in-1 adapters. Ensure the gaskets are in good condition and properly seated between the condensate dish and the adapters.
3. Repair any joints that show signs of leakage in accordance with vent manufacturer's instructions.
4. When air is ducted to the boiler, verify that the air inlet pipe is connected and properly sealed.

WARNING

Failure to inspect for the above conditions and have them repaired can result in severe personal injury or death.

Check the Water System

1. Verify all system components are correctly installed and operational.
2. Check the cold fill pressure for the system, and verify it is correct. Refer to the minimum water pressure specifications in [Table 5, page 21](#).
3. Watch the system pressure as the boiler heats up during testing to ensure the pressure does not rise too high. Excessive pressure rise indicates an issue with the expansion tank, such as incorrect sizing or other performance issues.
4. Inspect automatic air vents and air separators.
 - a. Remove the air vent caps and briefly press the push valve to flush the vent. Reinstall the caps.

- b. Make sure the vents do not leak.
 - c. Replace any leaking vents.
5. Check the system water chemistry. See [page 79](#).

Check the Boiler Relief Valve

The safety relief valves must be inspected at least once every three years. This inspection must only be done by a plumbing contractor or authorized inspection agency, not by the owner.

However, the safety relief valve *lever* must be operated at least once per year to ensure waterways are clear. This can be done by a contractor, maintenance personnel, or owner.

Before operating any relief valve, ensure it is piped with its discharge in a safe area to avoid severe scald potential. See Relief Valve Installation on [page 20](#) before proceeding further.

1. Remove and inspect the valve and its components.
 - a. Ensure the valve has no corrosion, and make sure the valve and discharge line have not been tampered with or altered.
 - b. Water conditions or some natural occurring conditions may corrode the valve or its components over time, making the valve inoperative.
 - c. If the relief valve weeps or will not seat properly, replace the valve. Ensure the reason for the valve weeping is the valve itself, and not the over-pressurization of the system due to a waterlogging or under-sized expansion tank.
2. Operate the safety relief valve lever.
 - a. If no water flows when operating the lever, the valve is inoperative and must be replaced.
3. If relief valve replacement is necessary, shut down the boiler until a new relief valve has been installed by a licensed contractor or inspection agency.

WARNING

Failure to reinspect the boiler relief valve and its components as directed can cause unsafe pressure buildup, which can result in severe personal injury, death, or substantial property damage.

Annual Startup, continued

Check the Expansion Tank

Expansion tanks provide space for water to move in and out as the heating system water expands or contracts due to temperature increases or decreases. Tanks may be open, closed, diaphragm, or bladder type.

Open-type: Located above the highest radiator or baseboard unit, usually in the attic or a closet. This type has a gauge glass and overflow pipe to a drain.

Closed-type: Welded gas tight and located above the boiler. This tank is partially filled with water, leaving an air cushion for expansion.

- Make sure a closed-type tank is fitted with a tank fitting, such as the B&G Airtrol. This fitting reduces gravity circulation of air-saturated tank water back to the system. It also prevents the air from bubbling up through the water as it returns from the system.
- Do not use automatic air vents in systems with closed-type tanks. The air will escape from the system instead of returning to the tank. Eventually, the tank will waterlog and no longer control pressurization. The boiler relief valve will weep frequently.

Diaphragm- or bladder-type: Welded gas tight with a rubber membrane to separate the tank pressurizing air and the water. This tank may be located at any point in the system, but it is most often found near the boiler.

- Systems with a diaphragm- or bladder-type expansion tank require at least one automatic air vent, preferably located on top of an air eliminator, as shown in this manual.

If the relief valve tends to weep frequently, the expansion tank may be waterlogged or undersized.

- Closed-type: The tank is most likely waterlogged. Install a tank fitting if not already installed. Check the fill level per the fitting manufacturer's instructions. If the fill level is correct, check the tank size against the manufacturer's instructions. Replace with a larger tank if necessary.
- Diaphragm- or bladder-type: Check that the tank size is large enough for the system. If the tank is

too small, add one or more additional tanks as necessary to provide sufficient expansion. If the tank size is large enough, remove the tank from the system and check charge pressure. If the tank will not hold pressure, the membrane has been damaged, and the tank needs to be replaced.

Inspect the Ignition Electrode and Wiring

See the figures on [page 97](#) for the references below.

1. Shut off power to the boiler.
2. Close the external manual gas valve to ensure there is no gas flow to the unit.
3. Allow time for the boiler to cool to room temperature if it has been firing.
4. Disconnect the ground wire and ignition cable connected to the ignition electrode (item 8).
5. Use a 3 mm Allen wrench to remove the two screws securing the electrode to the heat exchanger cover plate (item 5). Carefully remove the ignition electrode assembly.
6. Discard the ignition electrode gasket.
7. Inspect the electrode and ceramic insulator.
 - a. Remove any white oxides that have accumulated on the ignition electrode using steel wool.
 - b. Clean the gasket surfaces on the electrode assembly flange and on the mating surface of the heat exchanger cover plate.
 - c. If the electrode is cracked or damage, or if it cannot be satisfactorily cleaned, replace it.
8. Slide the new gasket onto the ignition electrode. Set the assembly aside for later installation.
9. Check that the ignition cable electrical resistance is between 950 and 1050 ohms. Replace the cable if not acceptable.
10. Verify that all wiring is in good condition and securely attached.
11. Inspect the boiler ground wire from the heat exchanger access cover to the ground terminal screw in the control tray.
 - a. Check that the resistance is 0 ohms.
 - b. Check the ground continuity of the wiring using a continuity meter.
 - c. Replace the ground wires if the results are not satisfactory.
12. The ignition electrode rods should be parallel, and the spark gap should be 3.5 mm.

Inspect the Flame Sense Rod and Wiring

1. Disconnect the flame sense wire connected to the flame sense rod. See item 9 in the figures on this page.
2. Use a 3 mm Allen wrench to remove the two screws securing the flame sense rod assembly to the heat exchanger cover plate. Carefully remove the flame sense rod.
3. Discard the flame sense rod gasket.
4. Inspect the flame sense rod and ceramic.
 - a. Remove any white oxides that have accumulated on the flame sense rod.
 - b. Clean the gasket surfaces on the flame sense assembly flange and on the mating surface of the heat exchanger cover plate.
 - c. If the flame sense rod is warped or cannot be satisfactorily cleaned, or if the ceramic is cracked or damaged, replace the flame sense rod assembly.
5. Slide the new gasket onto the flame sense rod assembly. Set the assembly aside for later installation.
6. Inspect the flame sense wire harness from the flame sense connector to the connector at the control module in the boiler control tray.
 - a. Check that the resistance is 0 ohms.
 - b. Replace the flame sense wire harness if results are not satisfactory. See the Parts section starting on [page 111](#) for ordering information.

Figure 68 Boiler interior assembled view

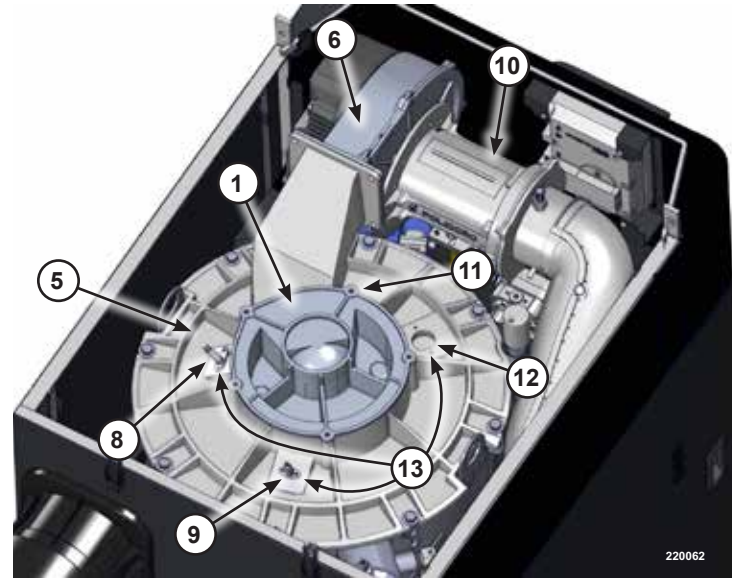
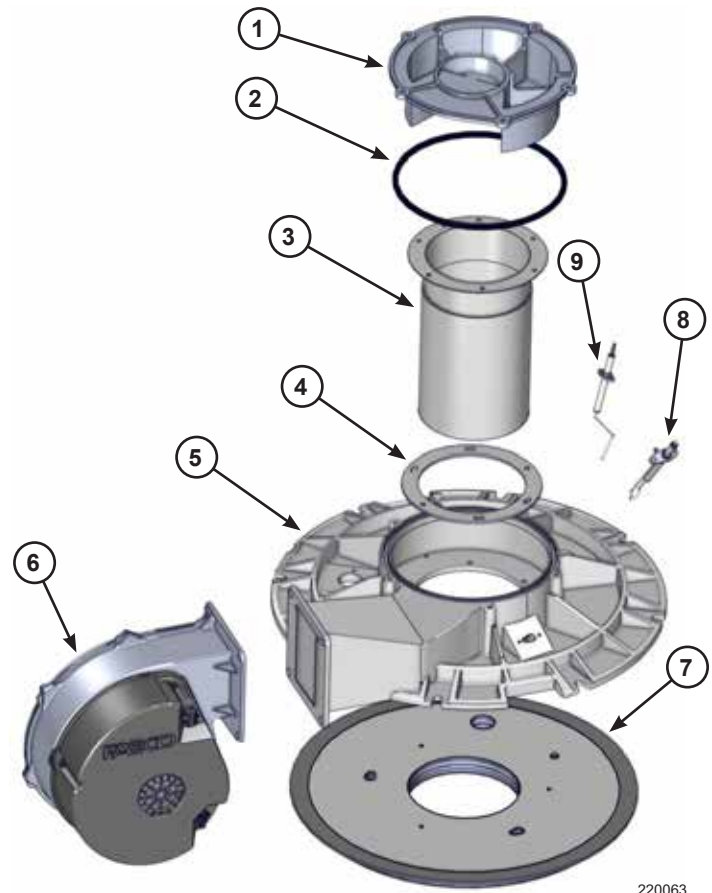

Figure 69 Boiler interior exploded view



Legend – Figure 68 and Figure 69

1. Burner access hatch	6. Blower	11. M5 bolts (x5)
2. Burner access hatch seal	7. Cover plate insulation with integrated seal.	12. Sight glass
3. Burner	8. Ignition electrode (igniter)	13. M4 bolts - two each for the igniter, flame sense, and sight glass
4. Ceramic fiber burner gasket	9. Flame sense	
5. Cover plate	10. Mixer	

Annual Startup, continued

Inspect and Clean the Burner

⚠WARNING

The boiler contains ceramic fiber materials. Use care when handling these materials per instructions on [page 91](#). Failure to comply can result in severe personal injury or death.

See the figures on [page 97](#) for the references below.

1. Use an 8 mm wrench or socket to remove the five M5 bolts (item 11) that secure the burner access hatch (item 1) to the heat exchanger cover plate (item 5).
2. Remove the burner access hatch.
3. Use a 10 mm socket or wrench to remove the six M5 bolts securing the burner.
4. Use caution when removing the burner (item 3). Pull it directly up and out.

NOTICE

DO NOT angle the burner when removing it. Angling the burner could cause it to strike and damage the insulation.

NOTICE

If the insulation has been damaged it must be replaced. If fragments from the insulation have fallen into the heat exchanger, the heat exchanger must be thoroughly cleaned.

5. Remove and discard the burner gasket (item 4).
6. Inspect the burner access hatch seal (item 2). If the seal is damaged in any way, discard and use a new seal during reassembly.

⚠WARNING

Replace damaged or stretched gaskets before placing the boiler back into operation. Failure to comply can result in severe personal injury, death, or substantial property damage.

7. Inspect the interior of the burner. Brush and vacuum the interior if needed to remove lint or sediment. Alternatively, clean with a water spray from inside the burner.

8. Inspect the burner exterior. It must be in good condition with no visible damage.
9. Clean the underside of the burner flange with a soft brush to remove any remaining gasket fragments.
10. Set the burner aside for later installation. The burner must be completely dry before reinstalling.

Inspect the Combustion Chamber

1. Use a trouble light and inspection mirror to inspect the interior of the heat exchanger through the burner opening in the cover plate.
2. Make sure there is no debris inside the heat exchanger.
3. Use the mirror to check the condition of the cover plate insulation with the integrated seal that is attached to the bottom of the heat exchanger cover plate. It must be in good condition with no indication of damage or sagging. Ensure the insulation is tightly installed on the cover plate and the bolts are secure.
4. Make sure there are no signs of overheating or flue gas leakage.
5. If visual inspection of the heat exchanger indicates the need for cleaning, remove the heat exchanger cover plate and fully inspect and clean the interior. Follow the procedures on [page 99](#).
6. Replace any parts for any components that may be damaged or show signs of leaking.

⚠WARNING

Damaged or leaking components must be replaced. Failure to comply can result in severe personal injury, death, or substantial property damage.

Cleaning the Heat Exchanger - Water Side

In order for the efficiency of boilers to increase beyond the condensing limit, new materials have been introduced for the heat exchanger, including stainless steel. Stainless steel has excellent heat transfer characteristics. It is also light in weight.

The materials now used require cleaning solutions that differ from those used in conventional cast iron and steel boilers. WM Technologies recommends Sentinel X400 for cleaning the boiler.

WARNING

One common cleaning method that CANNOT be used with systems containing stainless steel is a solution of trisodium phosphate, commonly referred to as TSP. Failure to comply can result in severe personal injury, death, or substantial property damage.

Cleaning the Heat Exchanger - Flue Side

1. Shut down the boiler.
 - a. Follow the instructions under To Turn Off Gas to the Appliance in [Figure 64, page 83](#).
 - b. Do not drain the boiler unless it will be exposed to freezing temperatures. If using freeze prevention fluid in the system, do not drain.
2. Close the external manual gas valve to ensure there is no gas flow to the unit.
3. Safely bleed the excess gas from between the external manual shutoff and the gas valve.
4. Allow time for the boiler to cool to room temperature if it has been in operation.

Cover plate removal:

5. Before removing the cover plate, refer to the instructions on [page 98](#) for removing the burner.
6. Disconnect the two wire harnesses connected to the blower.
7. Label each of the pressure tubes on the silencer and then remove all tubes.
8. Using two pipe wrenches, remove the gas flex line from the inlet pipe for the automatic gas valve.

9. Disconnect the blower from the cover plate with a 13 mm wrench or socket. Carefully lift the blower, mixer, and gas valve assembly out of the boiler and set aside.
10. Using a 5 mm Allen wrench, loosen all bolts holding the cover plate to the heat exchanger.
11. Remove the cover plate with insulation and set it aside.

Water spray the heat exchanger:

12. Disconnect the condensate trap at the bottom of the heat exchanger so debris will not clog the trap.
 - a. Loosen the hose clamp that secures the trap to the condensate drain. Slide the trap off and move it out of the way to expose the drain.
 - b. Place a pan under the condensate trap outlet to collect water and debris.
13. Use the combustion chamber opening to spray water down into the heat exchanger tubes. Continue spraying until all debris in the tubes has been flushed into the base.
14. Spray water through the condensate line to thoroughly clean it.
15. Remove the pan and reinstall the condensate line.
16. Do not spray the burner or cover plate insulation. Avoid getting the burner or cover plate wet.

NOTICE

If the burner or cover plate do get wet, allow them to dry completely before reinstalling into the boiler. Do not operate the boiler if these components are wet.

Annual Startup, continued

Reinstall All Components

See the figures on [page 97](#), Figure 70, and [Figure 71, page 101](#) for the references below.

1. Place the cover plate onto the heat exchanger. Ensure the blower flange is facing the front of the boiler and square.
2. Install all bolts finger-tight from the heat exchanger to the cover plate.
3. Tighten all bolts in a star pattern with a 5 mm Allen wrench to secure the cover plate to the heat exchanger. Do not exceed 88 in-lbs (9.94 Nm).
4. Carefully place the blower, mixer, and gas valve assembly into the boiler.
 - a. Attach the blower to the cover plate and install the four nuts finger-tight to secure the assembly. Torque each nut to 88 in-lbs (9.94 Nm) using a 13 mm wrench.
 - b. Reinstall the flex gas line to the inlet pipe using two pipe wrenches.
 - c. Reinstall the harnesses to the blower.
 - d. Reattach the pressure tubes to the silencer. Check the labeling on each tube before attaching to ensure correct placement.
5. Reinstall the burner (item 3).
 - a. Insert a new burner gasket (item 4) into the heat exchanger cover plate (item 5).
 - b. Insert the burner into position. Use a torque wrench to tighten the six bolts in a star pattern. Do not exceed 44 in-lbs (5 Nm).
6. Insert the burner access hatch seal into the heat exchanger cover plate, and the burner access cover into position. Use a torque wrench to tighten the five bolts (item 11). Do not exceed 44 in-lbs (5 Nm).
7. Reinstall the flame sense rod assembly (item 9).
 - a. Insert the flame sense rod into the cover plate opening with the gasket in position. Verify that the alignment mark is facing towards the center of the cover plate.
 - b. Reinstall the two socket head screws finger tight. Use a torque wrench to tighten the screws. Do not exceed 20 in-lbs (2.25 Nm).
 - c. Reattach the wire to the flame sense rod.
8. Reinstall the igniter electrode assembly (item 8).
 - a. Insert the ignition electrode into the cover plate opening with the gasket in position.
 - b. Reinstall the two socket head screws finger tight. Use a torque wrench to tighten the screws. Do not exceed 20 in-lbs (2.25 Nm).
 - c. Reattach the igniter cable and ground wire to the igniter electrode assembly.
9. Reinstall the condensate trap assembly to the heat exchanger drain. Tighten the hose clamp to secure the trap to the drain.

Figure 70 Cover plate and gasket installation

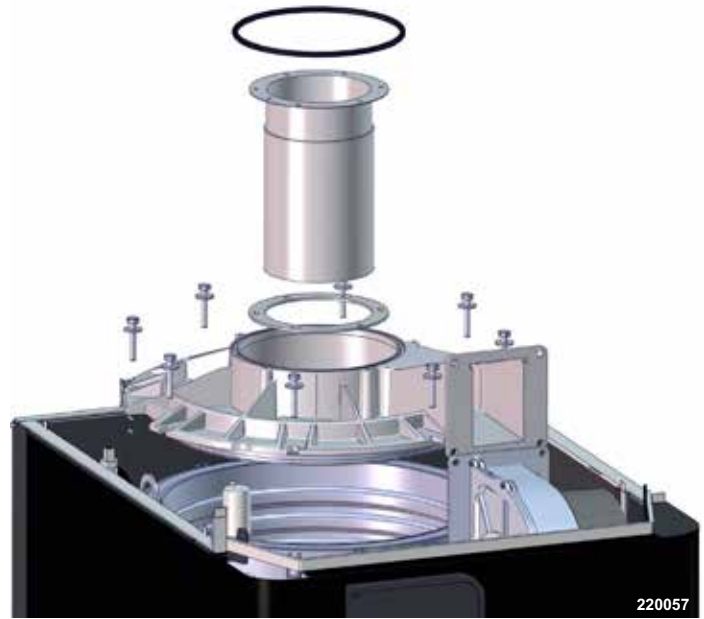

8. Reinstall the igniter electrode assembly (item 8).
 - a. Insert the ignition electrode into the cover plate opening with the gasket in position.
 - b. Reinstall the two socket head screws finger tight. Use a torque wrench to tighten the screws. Do not exceed 20 in-lbs (2.25 Nm).
 - c. Reattach the igniter cable and ground wire to the igniter electrode assembly.
9. Reinstall the condensate trap assembly to the heat exchanger drain. Tighten the hose clamp to secure the trap to the drain.

NOTICE

Use a torque wrench when tightening the bolts and screws. Do not exceed the stated torque or damage may occur.

⚠ WARNING

Check the seal of the ignition electrode, igniter gasket, and cover plate to ensure they are gas-tight. Failure to properly seal these parts could cause a gas leak or carbon monoxide emissions, which can result in severe personal injury or death.

Figure 71 Cover plate nut tightening sequences

- Gradually tighten the cover plate and burner plate access bolts in the sequence shown in the illustration.
- Burner torque: 44 in-lbs (5 Nm), 10 mm wrench
- Burner access plate torque: 44 in-lbs (5 Nm), 4 mm Allen wrench
- Cover plate torque: 88 in-lbs (9.94 Nm), 5 mm Allen wrench

⚠WARNING

Tighten the bolts as specified. If the tightening is not done properly, the cover plate could buckle and allow a flue gas leakage, which can result in severe personal injury, death, or substantial property damage.

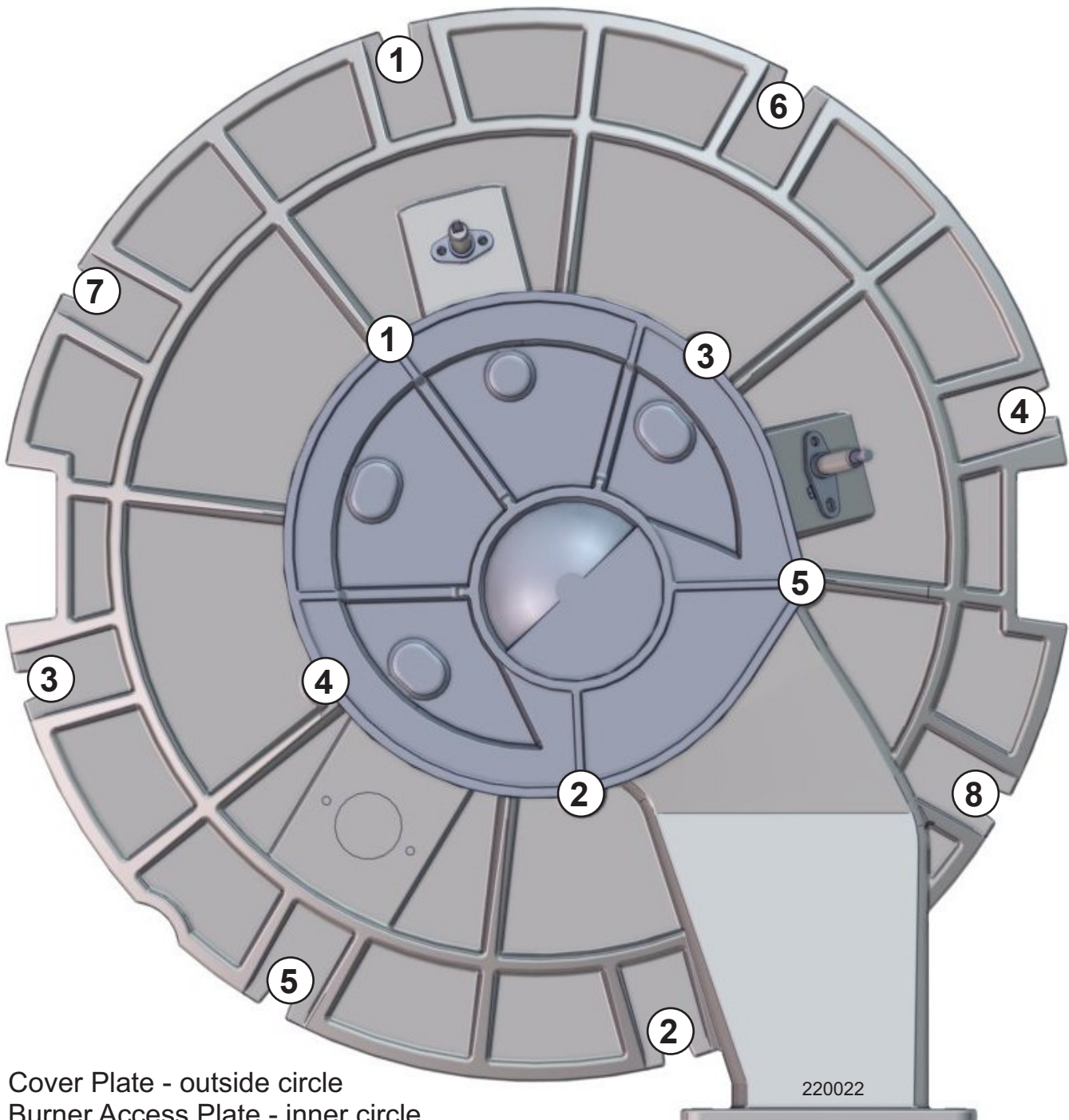

Cover Plate - outside circle
Burner Access Plate - inner circle

Annual Startup, continued

Inspecting the Pressure Switches

Inspect the pressure switches. Ensure the wire connects are properly connected and the tubes are secured to the pressure ports. Inspect the tubes for any signs of damage or debris. Replace if necessary.

1. High flue pressure switch:

- a. After checking the control settings, disconnect the tube connection with the condensate dish.
- b. Gently blow on the tube until the high flue pressure switch opens and the control displays a lockout error.
- c. Clear the lockout on the control. Confirm that the lockout does not reappear.
- d. Securely reconnect the tube connection with the condensate dish.

2. Minimum air flow pressure switches:

- a. Disconnect the tube connection on the positive side of the minimum airflow pressure switch at the silencer round port.
- b. Mark the wiring on the pressure switch indicating which wires go to which terminals.
- c. Disconnect the wiring from the pressure switch terminal.
- d. Gently blow into the tube until the pressure switch closes.
- e. Check continuity between pressure switch terminals. Ensure the switch changes from an open to a closed circuit.
- f. Reconnect the hose and wiring.

3. Wind detection switch:

- a. Disconnect the tube connection on the positive side of the normally closed pressure switch at the silencer round port.
- b. Mark the wiring on the pressure switch indicating which wires go to which terminals.
- c. Disconnect the wiring from the switch terminal.
- d. Gently blow into the tube until the pressure switch opens.
- e. Check continuity between pressure switch terminals. Ensure the switch changes from a closed to an open circuit.
- f. Reconnect the hose and wiring.

Replacing the Pressure Switches

Refer to Figure 72 for the instructions in this section.

1. High flue pressure switch:

- a. Disconnect the tube on the tap of the flue pressure switch.
- b. Disconnect the two wires running to the switch.
- c. Remove the two screws holding the flue pressure switch to the vertical support.
- d. Install the new flue pressure switch with two new screws.
- e. Reconnect the hose marked "Flue Pressure Switch."
- f. Reconnect the wires to the correct terminals.
 - J6-3 connects to the NC terminal.
 - J7-6 connects to the common terminal.

2. Minimum air flow (MAF) pressure switches:

- a. Disconnect the Wind Detection Switch (WDS) from the 4-way connector.
- b. Remove the jumper located on the front MAF common terminal. Leave the other side connected to the WDS.
- c. Remove the J6-2 wire running to the back MAF switch.
- d. Disconnect the two tubes connected to the silencer.
- e. Remove the two screws from the bracket.
- f. Remove the paired MAF switches.
- g. Install the new MAF switches with two new screws.
- h. Reconnect the WDS to the 4-way connector.
- i. Reinstall the jumper on the common terminal of the front MAF switch.
- j. Connect the tube tagged "Silencer Round Port" to the plastic port on the silencer.
- k. Connect the tube marked "Silencer 90 Port" to the brass barb on top of the silencer.
- l. Reconnect the J6-2 wire to the NO terminal on the back MAF switch.

Replacing the Pressure Switches, continued

3. Wind detection switch (WDS):

- a. Remove the jumper wire from the NC terminal on the WDS and the common terminal on the front minimum air flow (MAF) switch.
- b. Disconnect the H5 wire from the common terminal of the WDS.
- c. Disconnect the WDS from the 4-way connector.
- d. Disconnect the tube going to the flue pressure switch.
- e. Disconnect the tube going to the condensate dish barb at the back side of the heat exchanger.

- f. Remove the two screws holding the bracket to the control tray.
- g. Install the new WDS with two new screws.
- h. Reconnect the WDS to the 4-way connector of the paired MAF switches.
- i. Run the tube marked "Flue Pressure Switch" to the flue pressure switch.
- j. Connect the tube tagged "Condensate Dish" to the barb located on top of the condensate dish.
- k. Reconnect the jumper wire to the common terminal of the front MAF switch.
- l. Reconnect the H5 wire to the common terminal of the WDS.

Figure 72 Pressure switch diagrams

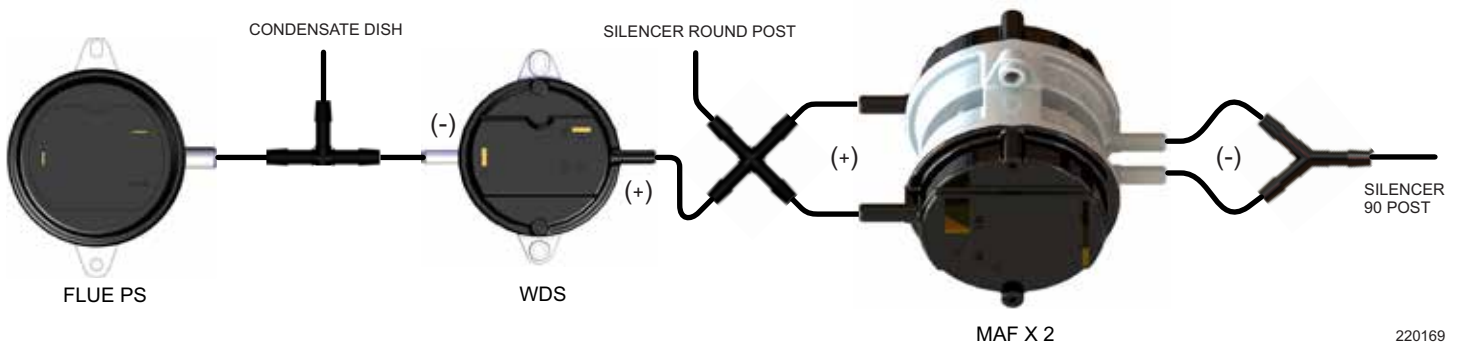

220169

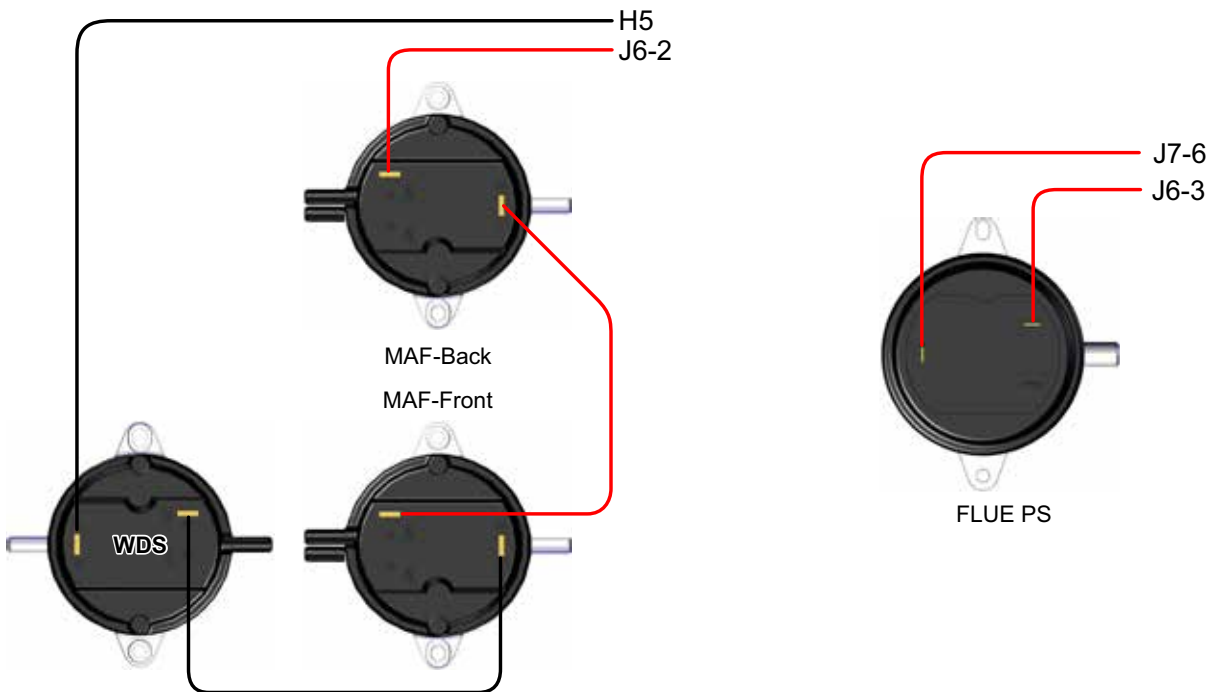

220170

Annual Startup, continued

Check Boiler Wiring

1. Inspect all boiler wiring. Make sure the wires are in good condition and securely attached.
2. Verify that all connectors are securely inserted.
3. Verify that the ground wires are connected to the jacket right side and the control tray cover.

Check Control Settings

Use the control display to navigate through all settings. Adjust the settings if necessary. Check the settings of the external limit controls (if any). Adjust as needed to accommodate the system design.

Perform Startup and Checks

1. Start the boiler and perform checks and tests specified in this manual.
2. Verify the cold fill pressure is correct and the operating pressure does not go too high. Adjust the water pressure and expansion tank charge pressure as necessary.
3. Complete the Verification Check List on [page 89](#).

⚠ WARNING

Failure to follow the provided procedures can cause a gas, air, or exhaust gas leak, which can result in severe personal injury, death, or substantial property damage.

Low Water Cut-Off Test

The boiler is furnished with a probe-type low water cut-off (LWCO). The probe is installed on the heat exchanger in order to detect the presence of water at the highest possible location in the boiler. The probe is connected to the LWCO circuit board by a single wire. The LWCO circuit board is located inside the control panel, identified with a yellow label.

- **Test method 1:** Press and hold the red Push to Test button for at least five seconds.
- **Test method 2:** Turn off the boiler, then turn off the circulating pump. Isolate the boiler from the system. Drain the water level below the LWCO probe. Turn the boiler back on. It should not operate.
- **Test result (both methods):** A manual lockout reset error displaying 10010: Low Water Limit on the display touchscreen should occur. The red LED indicator on the LWCO will no longer be illuminated.
- If water was emptied, turn off the boiler. Return the system to normal operation by refilling with water, restarting the circulating pump, and then turning on the boiler.

Check the Burner Flame

⚠ WARNING

The boiler contains ceramic fiber materials. Use care when handling these materials per instructions on [page 91](#). Failure to comply can result in severe personal injury.

1. Inspect the burner flame through the observation window using the procedure outlined on pages [85-86](#).
2. If the flame is unsatisfactory at either high fire or low fire, check the combustion values. If the combustion is properly adjusted, turn off the boiler. Allow it to cool down.
3. Remove the burner and clean it thoroughly using a vacuum cleaner or water flush. To access the burner, follow the procedure beginning on [page 98](#).
 - a. Vacuum method - Be careful not to rub or scrape the fiber mesh.
 - b. Water flush method - Rinse the burner down. Allow time for the burner to dry completely before reinstalling.
4. When removing the burner, the burner gasket must be replaced. Follow all instructions on [page 100](#) to reinstall all components.
5. Restart the boiler and inspect the flame again at high and low fire.
6. If the flame is still not acceptable, check the combustion values again.
7. If the combustion cannot be properly adjusted, obtain a replacement burner from WM Technologies. See the Parts section starting on [page 111](#) for ordering information.

Check the Flame Signal

1. Check the flame signal at both high and low fire.
 - a. Touch the INFO button in the lower corner of the display to load the Information menu. This menu shows real-time, read-only boiler values, such as temperatures and relay states.
 - b. Scroll down the Information menu to find the Flame Signal value. This value displays the strength of the combustion flame (units = V) as measured by the ignition electrode and ionization probe.
 - c. When the boiler is in standby, prepurge, or postpurge, the flame signal should read 0V.
 - d. During main flame, a strong flame signal should read between 8-30V.
2. The flame signal value must be greater than 0.8V. If the flame signal drops below this level, the control will shut down the boiler operation.
3. A low flame signal may indicate a fouled flame sense rod.
 - a. See [Inspect the Flame Sense Rod and Wiring, page 97](#), to remove and inspect the flame sense rod.
 - b. If required, clean the flame sense rod.
 - c. Check the combustion values.
 - d. If cleaning the flame sense rod does not improve low flame sense, but the flame sense wiring is in good condition and ground continuity is satisfactory, replace the flame sense rod.
4. If flame sense remains low after rod replacement:
 - a. Inspect the vent and air piping.
 - b. Inspect the heat exchanger. See the procedure for removal and installation on pages [99-101](#).
 - c. Clean the heat exchanger as described in this manual as necessary.

Annual Startup, continued

Check the Flue Gas Temperature

1. Set the boiler to high fire.
2. Adjust the control display to view flue gas temperature and boiler return temperature.
3. The flue gas temperature should be no more than 50°F higher than the boiler return temperature.
 - a. If the flue temperature is higher than this, shut down the boiler. Allow it to cool down.
 - b. Follow the procedure starting on [page 99](#) to clean the heat exchanger.

Check Blower Speeds

For installations at altitudes above 2,000 ft., make sure the control is set up for the correct blower RPM for low fire and ignition rates to compensate for high altitude conditions.

1. Use the control display to navigate to Manual Control Firing Rate. See the SVF Advanced Manual (part number 550-100-292) for navigation instructions and the complete diagnostics menu.
2. Set the firing rate to 0% (low fire). Write down the blower RPM value shown. Compare it to the value in [Table 14, page 107](#). The value should be no less than the minimum setting, and no higher than the ignition factory setting listed. Low fire rate (% of max rate) is adjusted in the setup menu.
3. Set the firing rate to 100% (high fire).
4. Write down the blower RPM value. It should be within 200 RPM of the value given in [Table 14, page 107](#).
5. If any of the values are outside the ranges listed in the previous steps, contact WM Technologies for technical assistance.

WARNING

High Fire rpms listed in [Table 14, page 107](#) are the maximum allowable control setting. Boilers from the factory may have a lower default value than the maximum value listed.

High Altitude

The boiler will automatically derate the BTU values listed in [Table 14, page 107](#) at altitudes over 2,000 ft. above sea level.

In the USA, input rates are derated 4% for each 1,000 ft. above sea level after 2,000 ft.. This is in accordance with the National Fuel Gas Code – ANSI Z223.1/NFPA 54, latest edition.

WARNING

Do not adjust the ignition RPM or other fan settings except as outlined in the High Altitude Fan Speed Setup section on [page 75](#). High altitude installation will require ignition RPM adjustment based on [Table 14, page 107](#). Failure to comply can result in severe personal injury, death, or substantial property damage.

IMPORTANT

For elevations above 11,000 ft. in the USA, please contact WM Technologies Technical Support for details.

In Canada, input rates are derated 10% for altitudes of 2,000 ft. to 4,500 ft. above sea level. This is in accordance with the Natural Gas and Propane Installation Code – CAN/CSA B149.1. Please use the appropriate fan speed settings for high altitude provided in this manual.

For elevation beyond 4,500 ft. in Canada, please consult local codes and Provincial Authorities having jurisdiction.

Table 14 Natural gas (NG) and propane (LP) firing rates and corresponding blower speeds (low fire and high fire), for altitudes up to 2,000 ft. (default settings), and for high altitudes (above 2,000 ft.).

Low Fire													
Model and Fuel Type		725 NG			725 LP			850 NG			850 LP		
Altitude (ft.)	%	RPM (max setting)	BTU/hr	CO ₂	RPM (max setting)	BTU/hr	CO ₂	RPM (max setting)	BTU/hr	CO ₂	RPM (max setting)	BTU/hr	CO ₂
0-2,000	10%	1150	72500	8.75	1100	72500	10.00	1150	72500	8.75	1100	72500	10.00
3,000	10%	1240	72500	8.75	1190	72500	10.00	1240	72500	8.75	1190	72500	10.00
4,000	10%	1280	72500	8.75	1230	72500	10.00	1280	72500	8.75	1230	72500	10.00
5,000	10%	1310	72500	8.75	1260	72500	10.00	1310	72500	8.75	1260	72500	10.00
6,000	10%	1350	72500	8.75	1300	72500	10.00	1350	72500	8.75	1300	72500	10.00
7,000	10%	1380	72500	8.75	1350	72500	10.00	1380	72500	8.75	1350	72500	10.00
8,000	10%	1410	72500	8.75	1400	72500	10.00	1410	72500	8.75	1400	72500	10.00
9,000	10%	1450	72500	8.75	1450	72500	10.00	1450	72500	8.75	1450	72500	10.00
10,000	10%	1480	72500	8.75	1500	72500	10.00	1480	72500	8.75	1500	72500	10.00
11,000	10%	1510	72500	8.75	1550	72500	10.00	1510	72500	8.75	1550	72500	10.00
High Fire (Max setting is necessary to achieve 100% rate in some conditions)													
Model and Fuel Type		725 NG			725 LP			850 NG			850 LP		
Altitude (ft.)	%	RPM (max setting)	BTU/hr	CO ₂	RPM (max setting)	BTU/hr	CO ₂	RPM (max setting)	BTU/hr	CO ₂	RPM (max setting)	BTU/hr	CO ₂
0-2,000	100%	6050	725000	9.25	5890	725000	10.50	7000	850000	9.25	6800	850000	10.50
3,000	100%	6050	638000	9.25	5890	638000	10.50	7000	748000	9.25	6800	748000	10.50
4,000	100%	6050	609000	9.25	5890	609000	10.50	7000	714000	9.25	6800	714000	10.50
5,000	100%	6050	580000	9.25	5890	580000	10.50	7000	680000	9.25	6800	680000	10.50
6,000	100%	6050	551000	9.25	5890	551000	10.25	7000	646000	9.25	6760	646000	10.25
7,000	100%	6050	522000	9.25	5890	522000	10.25	7000	612000	9.25	6670	612000	10.25
8,000	100%	6050	493000	9.25	5890	493000	10.25	7000	578000	9.25	6580	578000	10.25
9,000	100%	6050	464000	9.25	5890	464000	10.25	7000	544000	9.25	6490	544000	10.25
10,000	100%	6050	435000	9.25	5890	435000	10.25	7000	510000	9.25	6400	510000	10.25
11,000	100%	6050	406000	9.25	5890	406000	10.25	7000	476000	9.25	6310	476000	10.25
Ignition RPM (Max setting is the highest RPM to be used for high altitude operations. Do not adjust the RPM except as outlined on page 75)													
Altitude (ft.)	725 NG (max setting)			725 LP (max setting)			850 NG (max setting)			850 LP (max setting)			
0-2,000	3500			3500			3500			3500			
3,000	3790			3800			3790			3800			
4,000	3910			3920			3910			3920			
5,000	4020			4040			4020			4040			
6,000	4130			4150			4130			4150			
7,000	4220			4260			4220			4260			
8,000	4310			4370			4310			4370			
9,000	4410			4470			4410			4470			
10,000	4500			4580			4500			4580			
11,000	4590			4690			4590			4690			



Annual Startup, continued

Manual Test Mode

Single Boiler:

1. Navigate to the Manual Control Firing Rate screen under the INFO/Service menu.
2. If the boiler is not yet in operation, generate a call for heat and wait until the burner is lit.
3. Enter in the desired percent of rate. Rate will be forced to this setting for 15 minutes.

Multiple Boilers:

1. Generate a call for heat on a Network Priority or a Local Priority.
 - a. Local Priority allows the force rate only on the boiler with the call for heat. Follow the single boiler procedure above.
 - b. Network Priority allows the force rate on any boiler in the network. Follow the procedure outlined in the next steps.
2. On the master boiler, navigate to the Manual Control Firing Rate screen under the INFO/Service menu. Select the boiler being tested.
3. The Manual Control Firing Rate screen will automatically appear on the selected boiler. On the selected boiler's control, press ENTER and select the desired force rate (high, medium, or low).

NOTICE

When forcing a rate on a Network Priority call, only boilers running Local Priority calls will remain in operation. All other boilers on the networks will not fire until the manual test has ended. Ensure that critical applications remain heated. Long periods of low heating can cause property damage.

4. The selected boiler will run at the forced rate until it is either returned to AUTO, or until 30 minutes of inactivity on the master control. To return the rate to AUTO, select End Manual Test on the master control's Manual Control Firing Rate screen.
5. To test the next boiler, return to the master and select the next boiler to test.

Reinstall the Jacket Door After Servicing

Reinstall the boiler jacket door after startup or servicing. The boiler front door, side panel, and top panel must all be securely fastened to the boiler to prevent the boiler from drawing air from inside the boiler room.

▲WARNING

Ensure the boiler jacket door is closed and securely fastened after startup or any servicing. Failure to comply can result in severe personal injury or death.

Review with the Owner

1. Review the User Manual with the owner.
2. Emphasize the need to follow the maintenance schedule.
3. Remind the owner of the need to call a licensed contractor should the boiler or system exhibit any unusual behavior.
4. Remind the owner to follow the proper shutdown procedure, and to schedule an annual startup at the beginning of the next heating season.

SECTION 6

Troubleshooting

This section is intended to provide solutions by troubleshooting various issues with the boiler. See the SVF Advanced Manual for complete information.

Section Contents

Troubleshooting - General	109
Errors and Lockouts	109

Troubleshooting - General

Always turn power off to the boiler before servicing and making connections. The boiler ON/OFF switch does not turn off all power to the boiler. Internal wiring is still powered when the switch is in the off position.

⚠WARNING

Turn off all power to the boiler when servicing. Failure to comply can cause electrical surges or electrical shock, which can result in severe personal injury, death, or substantial property damage.

⚠WARNING

Wiring errors can cause improper and dangerous operation. Label all wires to ensure proper connection. Never jumper (bypass) any device except for momentary testing. Failure to comply can result in severe personal injury, death, or substantial property damage.

If assistance is required, please complete the Installation and Service Certificate on [page 124](#) before calling WM Technologies Technical Services. The CP number can be found on the boiler top jacket panel next to the air inlet connection.

Errors and Lockouts

Control Display

The control will display graphical or text based error descriptions to announce any problems with the boiler. There are two types of lockouts.

1. Manual reset lockouts. The operator must physically press the on-screen or device's reset button.

2. Automatic reset lockouts. This lockout resolves with a self-reset when the error condition clears.

Loss of Power

In the event of a power failure, the entire boiler will de-energize. The signal relays used to command auxiliary devices connected to the boiler will also lose power and deactivate. The sequence of operation will resume when power is restored as shown in step 3, [page 78](#). The control will retain any present error/lockout errors when power is restored.

Loss of Water Level

The low water switch opens when there is an insufficient water level in the boiler. The control will display 10010: "Low Water Limit," close the gas valve, and lock the boiler out. When the water level is corrected, and the on-screen reset button is pressed, the boiler will reset and resume the sequence of operation as shown in step 3, [page 78](#).

Low Gas Pressure

The low gas pressure switch opens when there is insufficient gas pressure available. If an external gas supply shut-off valve is closed for any reason, a low gas condition will result. The control will display 10012: "Low Gas Limit," close the gas valve, and lock the boiler out. When proper gas pressure is restored, and the on-screen reset button is pressed, the boiler will reset and resume the sequence of operation.

High Gas Pressure

The high gas pressure switch opens when there is excessive gas pressure for the proper operation of the boiler. The control will display 10011: "High Gas Limit," close the gas valve, and lock the boiler out. When proper gas pressure is restored, and the on-screen reset button is pressed, the boiler will reset and resume the sequence of operation.



Errors and Lockouts, continued

High Water Temperature

When the boiler water has exceeded both the operating temperature limit and the manual reset high temperature limit, the control will display 10009: "High Temperature Limit," close the gas valve, and lock the boiler out. When the water temperature falls below the high limit temperature setting, the boiler will remain locked out until the water high temperature limit switch is manually reset, and the on-screen reset button is pressed. Once reset, the control will resume the sequence of operation as shown in step 3, [page 78](#).

Low Air

If the control displays either 65: "Interrupted Airflow Switch OFF," or 66: "Interrupted Airflow Switch ON," it indicates improper airflow through the boiler.

- Verify proper standby blower operation. When the boiler is in "Standby," the blower should also be in standby.
- Check for obstructions of the combustion air intake and exhaust (flue) piping.
- Ensure the hoses leading to the air switches are not kinked or obstructed. An error related to the air switch does not necessarily mean that the air switch is defective.

When 66: "Interrupted Airflow Switch ON" is displayed:

- Check that the air switch is open when the blower is offline.
- Ensure there is no air flow through the boiler when the blower is offline. An excessive negative draft in the flue piping can cause air flow through the offline boiler, which may be strong enough to maintain closure of the air switch.

When 65: "Interrupted Airflow Switch OFF" is displayed:

- Check that the air switch is closed when the blower is running. If the air switch does not close within five minutes during purge, the boiler locks out.
- Check that the burner is clean and that there are no obstructions to airflow in the intake or exhaust ducts. See inspection and cleaning instructions, starting on [page 98](#).

Flame Failure

In the event of a flame failure, the control may display one of the following error messages.

- 106: "Flame Lost in Main Flame Establish Period"
- 107: "Flame Lost Early in Run"
- 108: "Flame Lost in Run"
- 109: "Ignition Failed"
- 110: "Ignition Failure Occurred"

When the control displays 106, 107, or 108, the boiler lost the flame signal during operation. Check that the combustion is adjusted properly, the gas pressure is correct, and the ignition electrode, ignition wire, and gas valve are all functioning properly.

When the control displays 109 or 110, the boiler did not light during the trial for ignition. Check that the ignition electrode, ignition wire, and gas valve are functioning properly. Check that the direct spark ignition is visible through the flame observation port during the trial for ignition.

Flame Error

In the event of a flame error (premature or late flame signal), the control will display 105: "Flame Detected Out of Sequence." This may be caused by a failed or leaky gas valve or a flame or ionization rod malfunction. If gas valve leakage is suspected, the unit must be isolated by turning off the main gas supply line. Lockout/Tagout the boiler until qualified and knowledgeable service personnel are available to evaluate and repair or replace the failed parts. Check that the incoming gas pressures have not exceeded 14" W.C. (1/2 psig).

Flue Issue

When the normally-closed high exhaust back pressure switch opens, the control will display 10013: "High Back Pressure Limit." This may be caused by an obstruction in the flue piping, an obstruction in the combustion air intake, or a blocked condensate system. When the blockage is removed, the boiler will automatically restart. If no blockage is found, it may be necessary to replace the high exhaust back pressure switch.

SECTION 7

Parts

This section includes replacement parts and ordering information.

Section Contents

Miscellaneous Parts	111
Ordering	111
The SVF Commercial Condensing Water Boiler	112
Replacement Parts	114
Dimensions	120

Miscellaneous Parts

See Table 15 for miscellaneous part numbers and descriptions for ordering purposes.

Ordering

Replacement parts must be purchased through a WM Technologies distributor. Specify the boiler model and size when ordering. Include the description and part number of the replacement part. Part numbers are found on www.weil-mclain.com and the following pages.

CAUTION

Results from using modified, other manufactured parts, and parts not purchased through an authorized distributor will not be covered by warranty. These parts may damage the boiler or impair operation.

Table 15 Miscellaneous parts and kits

Description	Part Number
Condensate Neutralizer Kit	383600076
Pressure Relief Valve:	
Watts 740 3/4" x 1" 925,000 Btu/hr. 30 PSI	383600063
Watts 740 3/4" x 1" 1,352,000 Btu/hr. 50 PSI	383600064
Watts 174A 3/4" x 3/4" 1,400,000 Btu/hr. 80 PSI	383600521
Watts 174A 3/4" x 3/4" 1,695,000 Btu/hr. 100 PSI	384000149
Watts 174A 3/4" x 3/4" 2,445,000 Btu/hr. 150 PSI	384000150
Antifreeze, Sentinel X500 (5 gallons)	592900006
Corrosion Inhibitor, Sentinel X100 (5 gallons)	592900016
Corrosion Inhibitor, Sentinel X100 (50 gallons)	592900017
Inhibitor Quick-Test Kit	592900005
System Restorer, Sentinel X400 (1 Gallon)	592900028
System Restorer, Sentinel X400 (5 Gallons)	592900022
Bird Screens (2 required) — for 6" PVC vent and air pipes	384000392
Kit - Service Annual Maintenance Kit: (electrode igniter, flame sense rod, insulation, gaskets, fasteners)	384000379
Conversion Kit, Natural Gas to LP, SVF 725/850 (venturi, venturi gasket, O-ring, LP orifice, hardware, instructions) *PROPANE (LP) DESIGN AVAILABILITY PENDING*	384000380
Kit - Service Automatic Air Valve	384000153
Minimum Water Flow Switch Kit	384000324
Isolation Valve, 2-1/2" NPT	BP00000732
Replacement Isolation Valve Actuator	BP00000733
Isolation Valve Position Switch	BP00000734
Circulator Taco VR15M 1-1/2"	511405157
Wireless Outdoor Temperature Sensor Kit	384000325
System Water Temp Sensor (strap-on style)	383500601
Modbus Converter to BACnet	383600322
Modbus Converter to Lonworks	383600332

The SVF Commercial Condensing Water Boiler

Legend for Figure 73, page 113

- 1. Stainless steel heat exchanger**
99.88 square ft. of surface for heat transfer. SA-240 stainless steel, grades 316Ti, 316L, UNS S34035, and UNS S44400.
- 2. Burner/heat exchanger cover plate**
- 3. Blower**
Air enters through the air intake adapter, then enters the venturi. The blower pulls air and gas through the venturi and pushes the mixture into the burner. The advanced blower design and air inlet silencer yield very quiet operation.
- 4. Control Module (see Control Overview on page 73)**
The control module is used to configure boiler settings and monitor boiler operation. The touchscreen allows for changing the display mode, entering setting values, and resetting after lockout.
- 5. Transformer**
- 6. Ignition transformer**
- 7. ON/OFF switch**
- 8. Automatic gas valve**
The automatic gas valve incorporates two solenoid-operated valve seats. The valve senses the vacuum in the venturi (item 5) caused by flowing air. Gas flows in proportion to air flow, so the air to fuel ratio remains constant as blower speed and air flow changes.
- 9. Manual ball gas valve with pressure port**
- 10. Air vent - Automatic air vent**
- 11. Electrical entrance snap-in covers**
Knockouts are provided in the terminal box, allowing conduit entry right of the low-voltage and line-voltage field wiring terminal strips.
- 12. High gas pressure switch**
Mounted on the side of the gas valve.
- 13. Low gas pressure switch**
Connects to the port on the tee that is installed on the inlet gas pipe near the gas valve.
- 14. Air pressure switch**
Maximum flue pressure.
- 15. Paired Minimum Air Flow Switches**
- 16. Low water cutoff (shown in Top View)**
The low water cutoff is mounted on the heat exchanger. The LWCO test button is on the left side of the control panel. Manual reset is done through the main control.
- 17. Premix gas burner (not shown)**
Made with high-grade stainless steel and fiber mesh construction, the burner uses pre-mixed gas and air.
- 18. Ignition electrode**
The burner flame is ignited by applying a high voltage to the ignition electrode, which is located in the combustion chamber. This causes a spark (from electrode to ground).
- 19. Flame sense rod**
The flame sense rod measures flame signal after ignition.
- 20. Flame inspection windows**
Quartz glass windows provide a view of the burner surface and flame.
- 21. Water outlet pipe (system supply)**
2-1/2" MNPT fittings.
- 22. Water return pipe (system return)**
2-1/2" MNPT fittings.
- 23. Gauge port (not shown)**
The pressure and temperature gauge is shipped loose for field installation. Contractor must supply and install a tee on the water outlet pipe (system supply) for this installation.
- 24. Relief valve nipple (not shown)**
The relief valve is shipped loose for field installation. Contractor must supply and install a tee on the water outlet pipe (system supply) for this installation.
- 25. Temperature sensor port - outlet water temperature**
The outlet sensor port is located on top of the water outlet pipe (system supply), just outside the heat exchanger.
- 26. Temperature sensor port - inlet water temperature**
The return sensor port is located on top of the water return pipe (system return), just outside the heat exchanger.
- 27. Flue temperature port sensor (not shown)**
- 28. Gas connection - 1-1/4" MNPT**
- 29. Vent connection**
3-in-1 adapter allows PVC/CPVC, PolyPro, or stainless steel connection. If using PP or SS brands other than M&G DuraVent, consult the manufacturer for proper adapter.
- 30. Jacket panels**
The front and side jacket panels are removable for access to the blower, gas valve, pressure switches, controls, and ASME rating plate.
- 31. Boiler top panel**
- 32. Casters (used for locating the boiler only)**
- 33. Leveling legs (extended after the boiler is in position)**
- 34. Heat exchanger drain connection**
- 35. Condensate trap**
- 36. ASME rating plate**
This plate has all the ASME Section IV required information.
- 37. Air inlet adapter**
Storage location until direct vent installation.
- 38. Silencer**
- 39. Mixer**
- 40. Wind Detection Switch**

Figure 73 The SVF commercial condensing water boiler

Electrical Panel Components

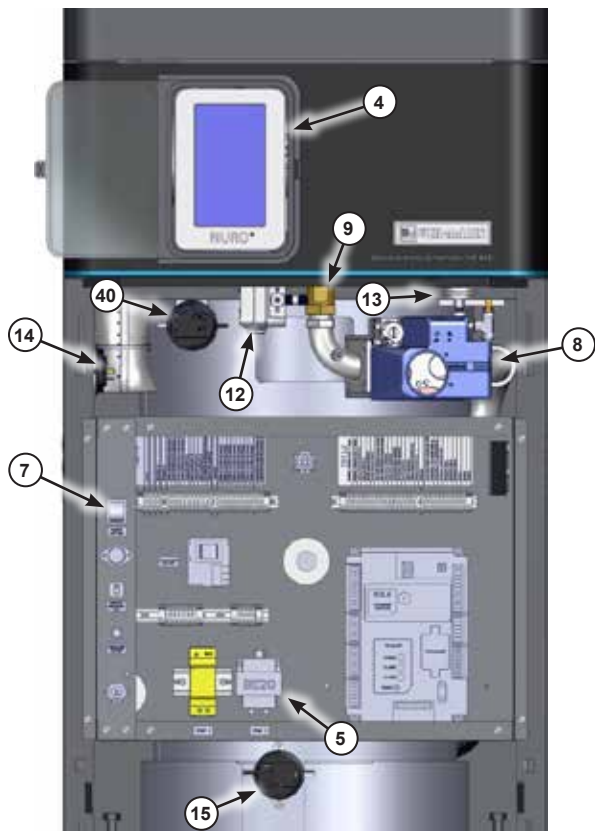

Components - Top View

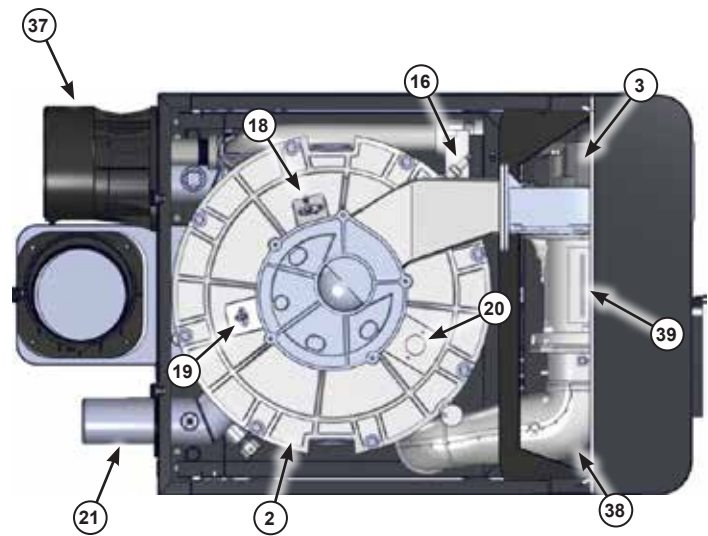

Components - Back View

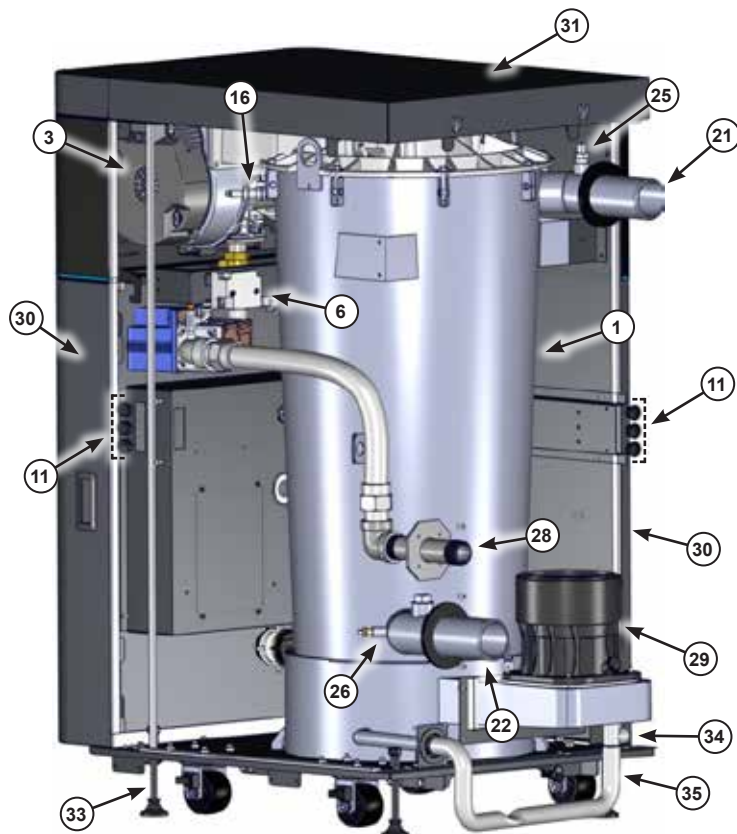

Components - Front View

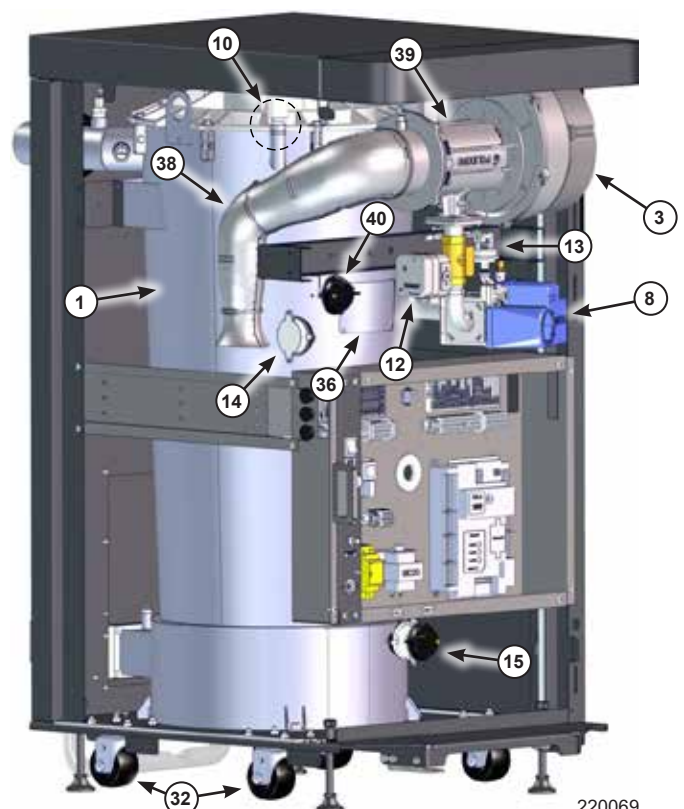

Figure 74 Jacket parts

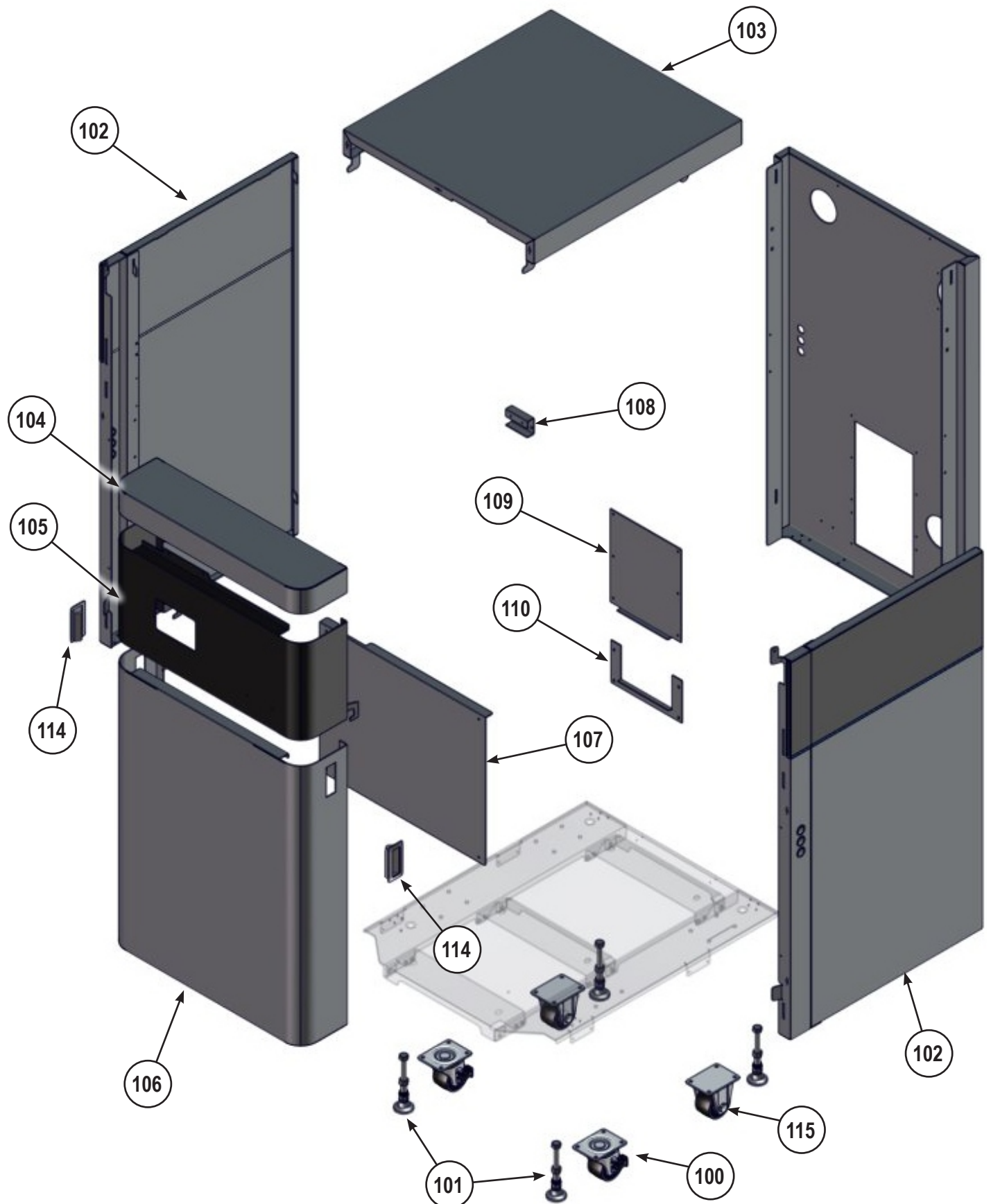

Figure 75 Combustion, condensate

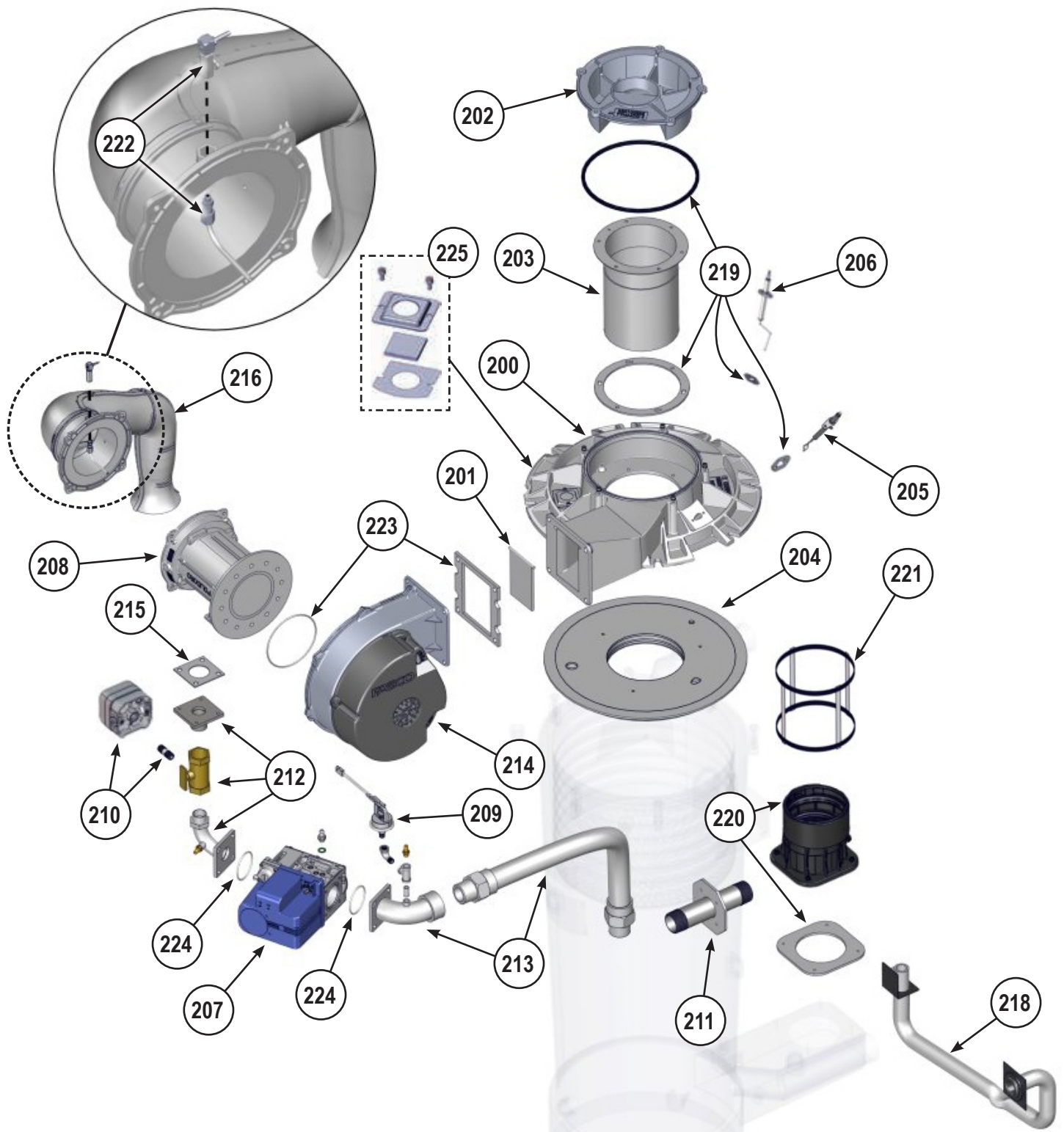
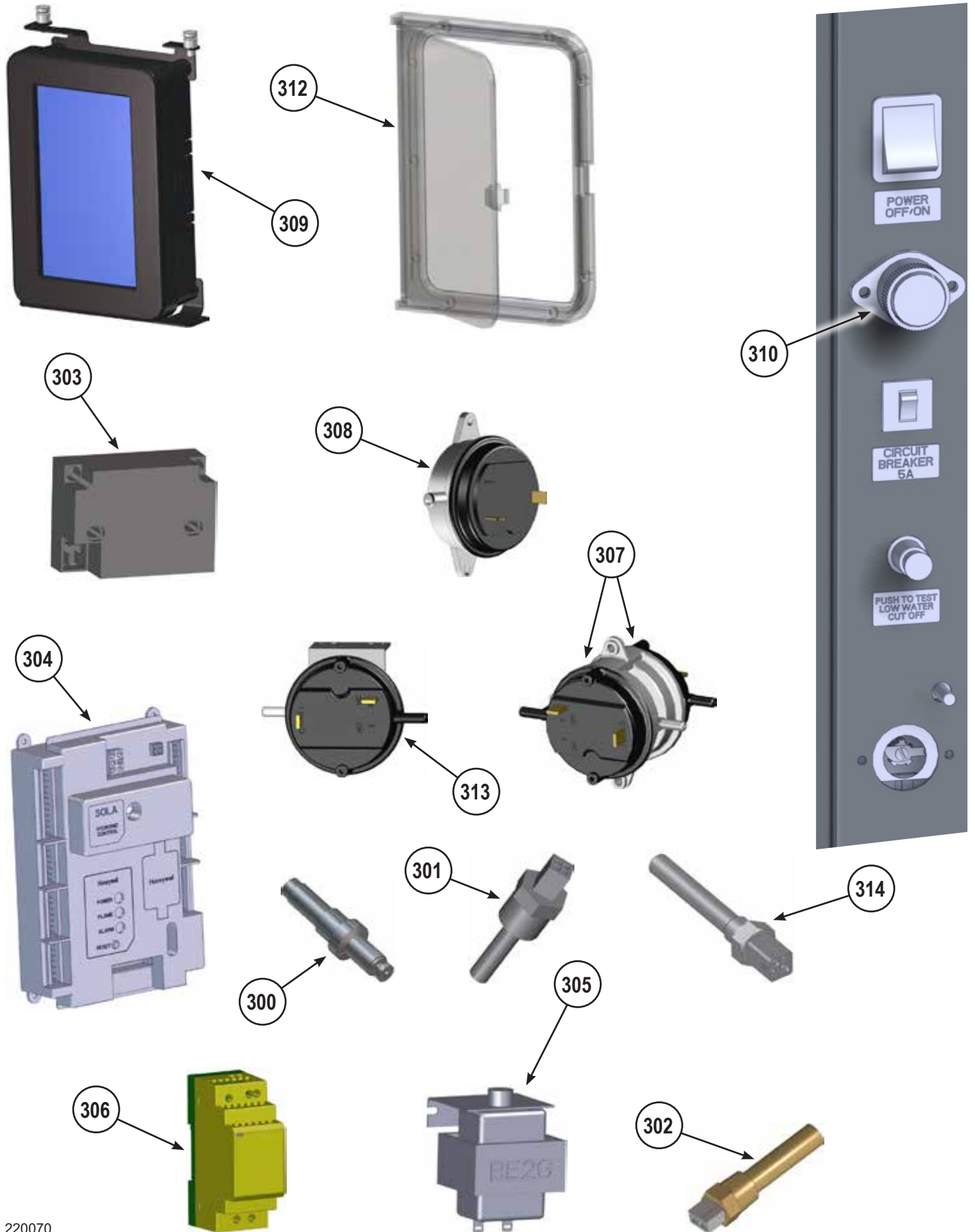
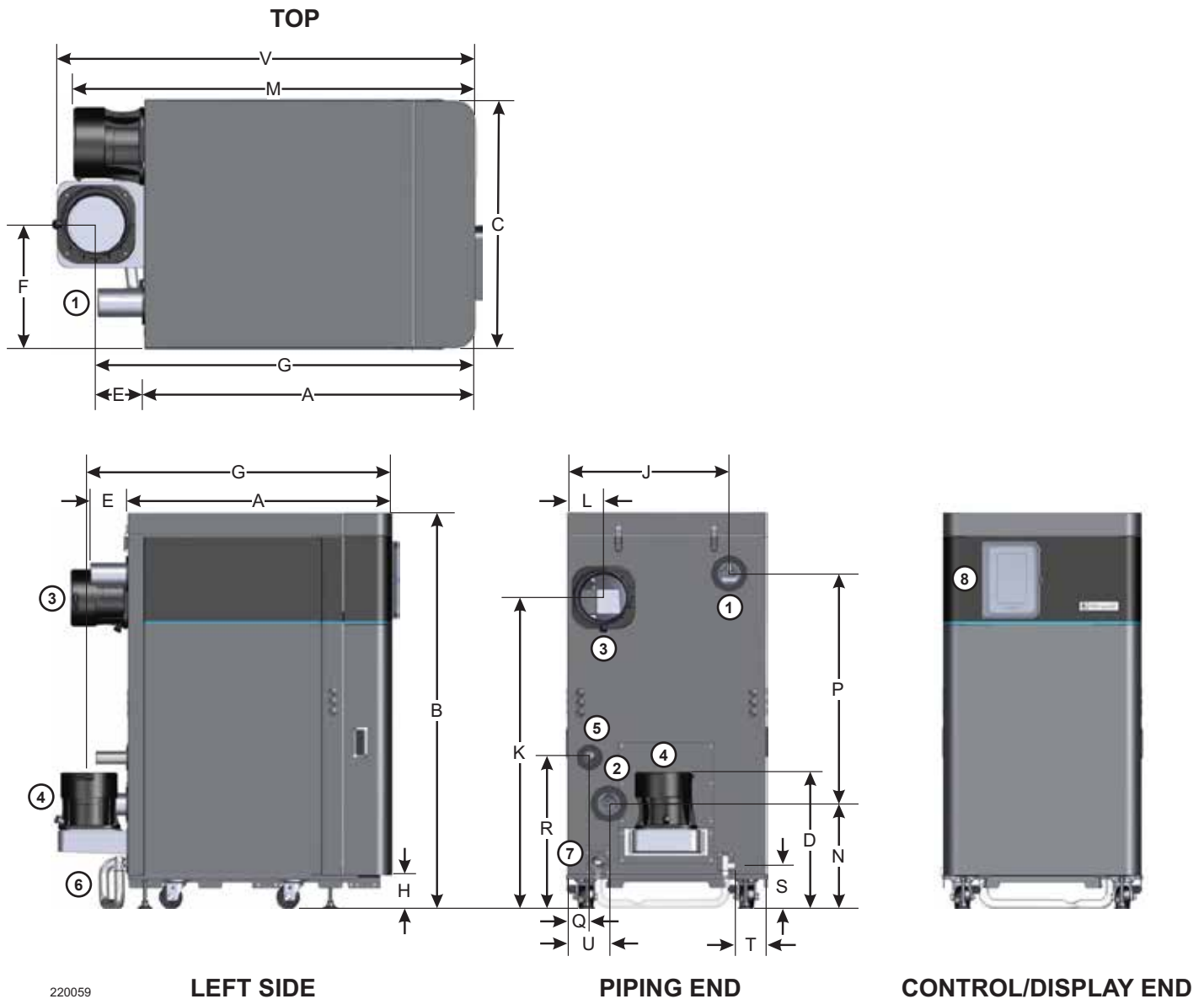

Figure 76 Controls, sensors



Dimensions

Figure 77 Dimensional data



220059

Legend – Figure 77

- | | |
|----------------------------------|-----------------------------|
| 1. Boiler water out, 2.5" NPT | 5. Gas in, 1-1/4" NPT |
| 2. Boiler water in, 2.5" NPT | 6. Condensate trap assembly |
| 3. 3-in-1 air intake adapter, 6" | 7. Condensate drain tube |
| 4. 3-in-1 flue adapter, 6" | 8. Control |

SVF 725/850 DIMENSIONS (inches) - height dimensions given are based on casters resting on the ground. Add lifted boiler measurements to height dimensions accordingly.

A	B	C	D	E	F	G	H	J	K
33-3/8	49-13/16	24-7/8	17-1/16	4-3/4	12-1/16	38-3/16	4-1/4	20-5/16	39-3/16
L	M	N	P	Q	R	S	T	U	V
4-9/16	42-1/8	13-3/16	29	2-5/8	19-1/2	5-3/8	3-13/16	5-1/4	42-3/16

SECTION 8

Service Information

Section Contents

Ratings	121	Installation and Service Certificate	124
Maintenance Log	123	Notes	124

Ratings

Table 19 Multi-boiler ratings

Boilers in System		Total CSA Input	CSA Output / DOE Heating Capacity	Boiler H.P.	Net Water Rating	Manifold Combustion Air Duct Size
		Input, MBH	Output, MBH	-	MBH	Square Inches
SVF 725	SVF 850	-	Note 1	-	Note 2	
2		1450	1416	42.3	1232	725
	2	1700	1658	49.5	1442	850
3		2175	2124	63.4	1848	1088
	3	2550	2487	74.3	2163	1275
4		2900	2832	84.6	2464	1450
	4	3400	3316	99.0	2884	1700
5		3625	3540	105.7	3080	1813
	5	4250	4145	123.8	3605	2125
6		4350	4248	126.9	3696	2175
	6	5100	4974	148.6	4326	2550
7		5075	4956	148.0	4312	2538
	7	5950	5803	173.3	5047	2975
8		5800	5664	169.2	4928	2900
	8	6800	6632	198.1	5768	3400



Ratings, continued

Table 20 Ratings and engineering data

DOE



AHRI Certified Ratings

Boiler Model Number	Maximum Input	Minimum Input - Natural Gas	Minimum Input - Propane Gas	Gross Output	Net Rating	Thermal Efficiency	Boiler Water Content	Vent/Air Pipe Size	Stack/Vent Flow Rate	Boiler Weight (pounds)		
	Btuh (Note 1)	Btuh (Note 1)	Btuh (Note 1)	Btuh (Note 1)	Btuh (Note 2)	% (Note 3)	Gallons	Inches (Note 4)	scfm (Note 5)	Dry Weight (no water)	Operating Weight (filled)	Shipping Weight
SVF 725	725,000	72500	72500	708,000	616,000	97.7	16.5	6	150	532	669	675
SVF 850	850,000	72500	72500	829,000	721,000	97.5	16.5	6	175	532	669	675

Notes

- Ratings shown are for sea level applications only. For altitudes above sea level, the SVF boiler requires no modifications; it automatically derates itself by approximately 4% per 1,000 ft. above sea level. For elevations over 2,000 ft., see the High Altitude section on [page 106](#) for required control parameter changes. The length of the vent and air piping will affect the maximum input. See Table 21 below for derate % according to vent and air piping length.
- Net AHRI ratings are based on net installed radiation of sufficient quantity for the requirements of the building, and nothing needs to be added for normal piping and pickup. Ratings are based on a piping and pickup allowance of 1.15. An additional allowance should be made for unusual piping and pickup loads.
- Thermal efficiency is based on AHRI testing procedure AHRI 1500.
- SVF boilers can be direct vent or direct exhaust vented, either through a side wall or through the roof, as instructed in this manual and compliant with all local codes. SVF boilers require special venting, consistent with Category IV boilers. For Category II boiler systems, see pages [33](#) to [36](#). Use only the vent materials and methods identified in this manual.
- The values are for the stack flow rate at the maximum firing rate for the given boiler. The values can vary, depending on the location of the installation and the operating conditions.

Table 21 Derate due to vent and air piping length

Boiler Model	Determine vent/air piping equivalent length (ft.) - Use the length for L in the equations.		
	Derate % for Direct Exhaust	Derate % for Direct Vent	
		6" Vent / 6" Air Piping	6" Vent / 4" Air Piping
SVF 725/850	% Derate = L x .035	% Derate = L x .050	% Derate = L x .060
	<i>Example: If L = 75 ft., Derate % = 75 x .035 = 2.625</i>	<i>Example: If L = 75 ft., Derate % = 75 x .050 = 3.75</i>	<i>Example: If L = 75 ft., Derate % = 75 x .060 = 4.50</i>

This page intentionally left blank.

This page intentionally left blank.

