



# MODEL 891

With illuminating LED lights and a simple digital temperature control, this compact merchandiser uses circulating, heated air that will help maintain food at correct temperatures for an extended period of time. It can accommodate a variety of food products such as cookies, pizza, burritos, wrapped sandwiches and many more.

## FEATURES:

- Includes “Ready to Go” graphic and 1½” Channel graphics: HOT, FRESH, DELICIOUS
- Heated, forced air
- Overhead and rear LED illumination
- Double rear doors for product stocking
- 3 front doors for product removal
- 3 - 15" x 14½" Racks
- 4¼" spacing between racks
- Temperature range 90°F to 175°F
- Adjustable digital temperature control



## ELECTRICAL DATA:

<b>VOLTS:</b>	120	<b>AMPS:</b>	5.6	<b>WATTS:</b>	670
---------------	-----	--------------	-----	---------------	-----

- Best when operated on an individual branch circuit
- Approx. 57" NEMA 5-15P power cord



NEMA 5-15P

## DIMENSIONS:

- 15½"W × 17½"D × 22¾"H

## SHIPPING INFORMATION:

- SHIPPING DIMENSIONS: 19"W × 19"D × 28"H
- SHIPPING WEIGHT: 46 lbs.



FP140219 REV: ORIG

**IMPORTANT:** Read the following safety and operation instructions to avoid damage to equipment or property.



Plug unit into a properly grounded electrical outlet of the correct voltage, size, and plug configuration for this unit. We recommend usage on an individual branch circuit of at least 15 amps for best results. Failure to do so may result in decreased performance of the warmer.



Exterior surfaces on unit may get hot. Use caution when touching these areas to avoid injury.



Unplug warmer when not in use.

## OPERATION:

### EQUIPMENT SETUP

The amount of product placed in the warmer will affect the performance of the warmer. We suggest periodically checking the internal temperature of product and adjusting the temperature settings if necessary. Keep doors closed when not serving.

### OPERATING INSTRUCTIONS

This warmer is designed to maintain food product at or above the optimum temperature. It is not designed or intended to heat up or cook food to the serving temperature. Product is to be prepared to a temperature of above 160°F before placing in the warmer. Do not place product on its side as this will affect the internal holding temperatures of the product.

- General Description:
  - The 891 offers manual control of the TEMPERATURE setting
  - The TEMPERATURE can be set in 5°F increments
- Programming:
  - Plug unit in
  - Press ON/OFF
  - To program the warmer, hold SET button until a beep sounds and light above begins flashing
  - Adjust temperature by 5°F increments with up and down arrows
  - Once temperature is displayed, hold SET button until a beep sounds to exit program mode
  - You can double check the set point temperature after programming by pushing either the up or down arrow
  - Preset temperature will remain in memory if the unit is plugged in
  - **Temperature will return to default (160°F) when unplugged**



PARTS LIST:

MODEL 891

ITEM #	PART#	DESCRIPTION
1.	0027259	HI-LIMIT THERMOSTAT
2.	0027199SK	120V, 450W HEATING ELEMENT SERVICE KIT
3.	0027173SK	TEMPERATURE SENSOR
4.	0027683SK	REAR DOOR ASSEMBLY
5.	0022667	STRAIN RELIEF
6.	0027670	POWER CORD
7.	0027795SK	CONTROL BOARD & POWER BOARD SERVICE KIT
7A.	0027671SK	Control Board & Power board service kit for the following serial #'s ONLY: J050660-J050683
8.	0023057SK	FOOT SERVICE KIT
9.	0027202-15	RACK
10.	0027686SK	FRONT DOOR ASSEMBLY SERVICE KIT
11.	0027689	15" 120V, 150W FOIL HEATING ELEMENT
12.	0027198	12" LED COVER
13.	0027266SK	12" LED ASSEMBLY (x3)
14.	0027260SK	BLOWER MOTOR SERVICE KIT
15.	0027661SK	REAR DOOR MAGNET SERVICE KIT
*	I013633	"READY TO GO"/"HOT FRESH DELICIOUS" TOPPER
*	I013634	"READY TO GO"/"HOT FRESH DELICIOUS" PIZZA TOPPER
*	0027774	C-CHANNEL GRAPHIC KIT

# MODEL 891 EXPLODED VIEW

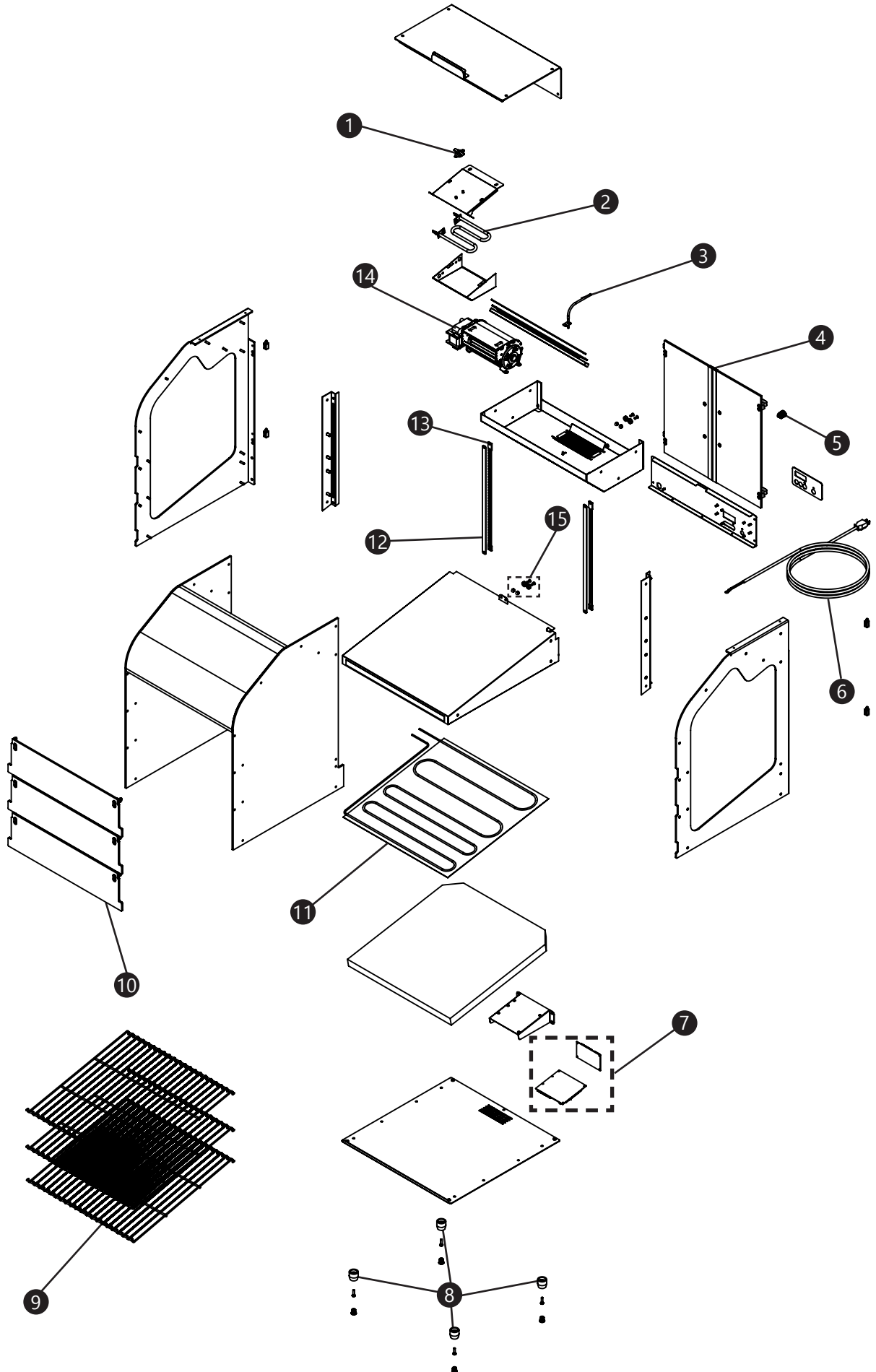

# MODEL 891 WIRING DIAGRAM

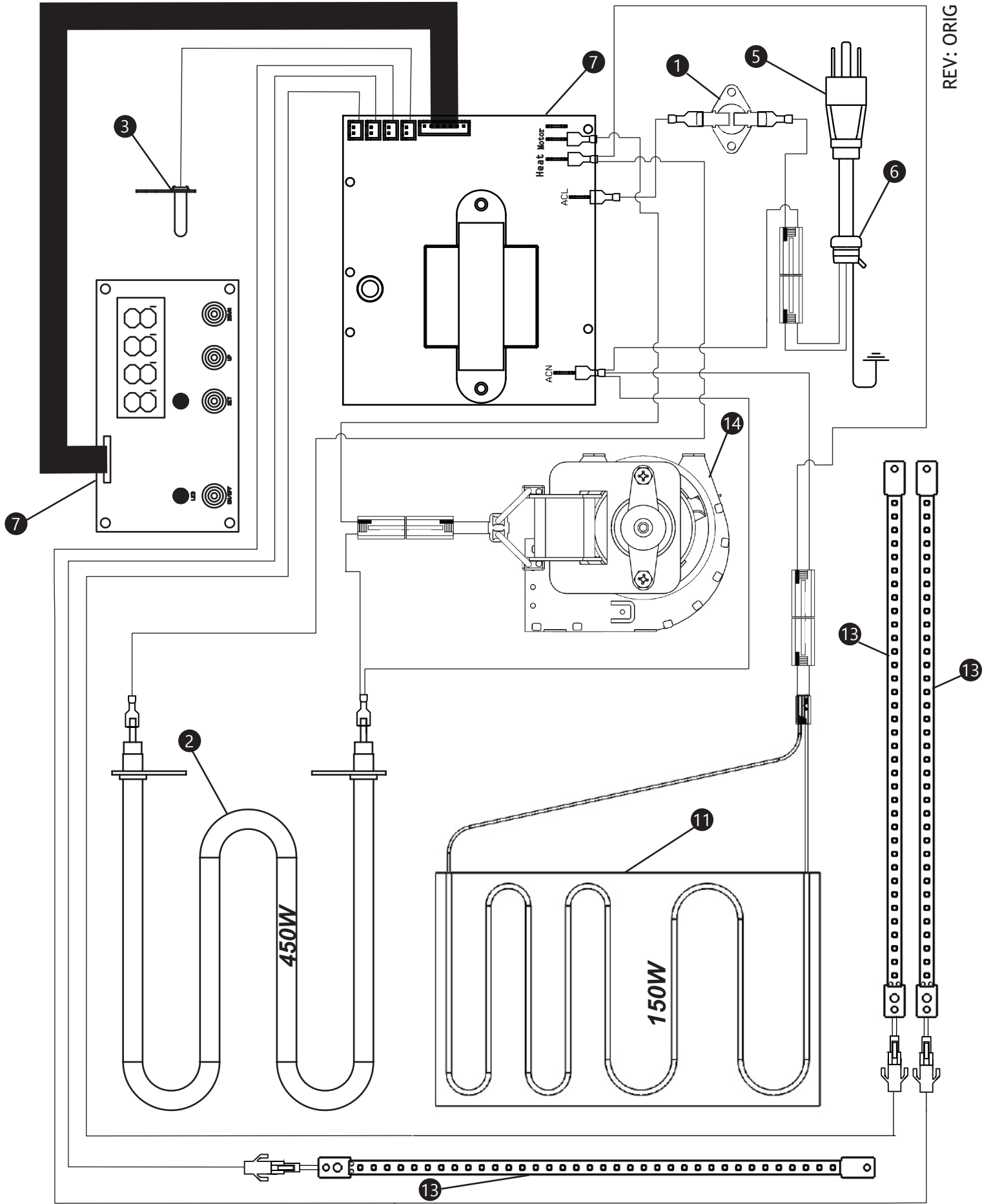

REV: ORIG

## 1 YEAR REPLACEMENT/EXCHANGE

Wisco Industries, Inc. warrants its equipment against defects in materials and workmanship subject to the following conditions:

Should any product fail to function in its intended manner under normal use within the limits defined in this warranty, Wisco Industries will determine if the item is to be repaired or replaced by Wisco Industries. Failure to follow authorizing instructions may void any claim and/or warranty.

\* Contact Wisco Industries for repair/replacement by calling (608) 835-3106 or toll free (800) 999-4726.

You can also email us at: [contact@wiscoind.com](mailto:contact@wiscoind.com)

\* An authorizing RMA# must be obtained through Wisco Industries BEFORE any warranty issues can be resolved. Failure to do so in advance may void the warranty/claim resulting in Wisco Industries not being responsible for any incurred expenses and/or charges.

\* At time of call Wisco Industries will assist you in:

- getting your unit replaced/exchanged
- and/or obtaining repair parts
- and/or authorizing a service agent

This warranty covers products shipped into the 48 contiguous United States, Hawaii and metropolitan areas of Alaska only. Warranty for international or areas not listed above will consist of replacement of parts only. There will be no labor coverage and parts must be shipped to an address within the 48 contiguous United States, Hawaii or metropolitan areas of Alaska only.

### Time Period

One year from date of shipment from our manufacturing facility. Parts replaced under this warranty are warranted for the un-expired portion of the original product warranty only.

### Exclusions

The following conditions are not covered by warranty:

- Equipment failure relating to improper installation and improper utility connection or supply.
- Equipment that has not been properly maintained or damage from improper cleaning and/or water damage to controls.
- Equipment that has not been used for its intended purpose or has been subject to misuse or misapplication, neglect, abuse, accident, alteration, negligence, damage during subsequent transit, delivery or installation, fire, flood, riot or act of god.
- Equipment that has the model number or serial number removed or altered.

WISCO INDUSTRIES, INC. DISCLAIMS AND EXCLUDES ANY AND ALL OTHER EXPRESS OR IMPLIED WARRANTIES, INCLUDING WITHOUT LIMITATION, ANY AND ALL WARRANTIES OF MERCHANTABILITY OR FITNESS FOR A PARTICULAR PURPOSE.

Buyer agrees that its SOLE AND EXCLUSIVE REMEDY against Wisco and Wisco's SOLE AND EXCLUSIVE LIABILITY arising out of any defect or nonconformity in the product shall be replacement/exchange of such nonconforming countertop food service equipment at Wisco's expense. No countertop food service equipment shall be returned without Wisco's consent. IT IS AGREED THAT WISCO'S MAXIMUM LIABILITY SHALL NOT IN ANY CASE EXCEED THE SALE PRICE FOR THE COUNTERTOP EQUIPMENT CLAIMED TO BE DEFECTIVE OR NONCONFORMING.

Without limiting the generality of the foregoing, SUCH WARRANTIES DO NOT COVER: Glass, plastic enclosures/panels, door assemblies, hardware, light bulbs & wire pizza oven heating elements.

---

## SHIPPING DAMAGE

If the outside packaging of your order is visibly dented, crushed, torn or otherwise significantly damaged, or if you move the carton and you hear broken glass, please reject the shipment while driver is still with you if possible. Please call us at (800)999-4726 or email [contact@wiscoind.com](mailto:contact@wiscoind.com) to notify us of the issue. We will confirm the damage with the carrier and re-ship your order immediately.

---

## RETURN POLICY

You may return any unused, undamaged items within 30 days of receipt at your expense. We will issue a refund in the form of your original payment, less a 20% restock fee. Wisco Industries will not reimburse any shipping and handling fees. All returns must be received in resalable condition. Wisco Industries will not accept a return with shipping damage.

If you would like to return an item please call us at 608-835-3106 or toll free at 1-800-999-4726 and ask for our Food Service Equipment Division or you may send an email to us at: [contact@wiscoind.com](mailto:contact@wiscoind.com) You will be given a return # and return instructions. We can not accept returns without a return #. Please be sure to include a copy of the packing list with the return.