

TEMP-GARD III



Pressure Balancing Shower/
Tub & Shower Valve
Z7300 Series

□ Operation □ Installation □ Maintenance Instructions □ Replacement Kits

- ⚠ **WARNING:** Cancer and Reproductive Harm - www.P65Warnings.ca.gov
- ⚠ **ADVERTENCIA:** Cáncer y daño reproductivo - www.P65Warnings.ca.gov
- ⚠ **AVERTISSEMENT:** Cancer et effets néfastes sur la reproduction - www.P65Warnings.ca.gov

INSTALLATION OF TEMP-GARD III SHOWER VALVE (Refer to page 4 for part no.)

1. Install rough piping and valve body as shown. **Do not use PEX or CPVC CTS piping from valve to tub spout, as the reduced ID results in too much back pressure for valve to function properly.** When facing valve, HOT "H" is on left and COLD "C" is on right. Tub port "T" should face down and shower port "S" should face upward. The ears on the valve at the 5 o'clock and 11 o'clock positions may be used to attach the valve to framing of wall if necessary.

FIGURE 1

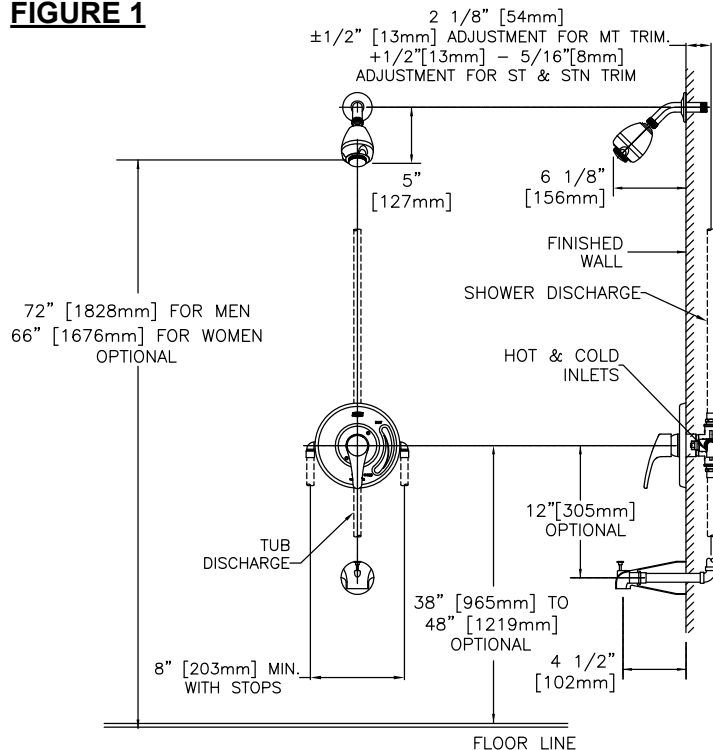

WARNING: Caution should be taken when heating valve for sweat connections to avoid damaging internal rubber and plastic components in valve.

FOR OPTIMUM VALVE PERFORMANCE, BALANCE SUPPLY PRESSURES TO LESS THAN 5 PSI PRESSURE DIFFERENTIAL BETWEEN HOT AND COLD WATER SUPPLIES.

2. Always install valve with mud guard (23) so that the indicated surface on mud guard is flush with finished wall. The hole in the wall should be 4" in diameter.
3. If valve is to be used for a shower only, wrap threads on tub plug (24) with teflon tape and install plug into tub port on shower valve.
4. When the final outer wall is finished remove mud guard and open both supply stops on valve by turning counter clockwise.
5. Loosen and remove escutcheon (19) from valve. Carefully remove cartridge (10) from valve by holding cartridge as close to the valve body (1) as possible and wiggling back and forth until cartridge comes out of the valve. Place thumb and finger on gray part of cartridge to remove it, as shown in Figure 4.
6. With the cartridges removed from all valves in the system, turn on water supply and flush the system of any debris. If the water coming out of the valve while flushing is going behind finished wall, a hose bib flushing out kit (RK7300-20HB) may be used to allow the water to be directed to a drain by attaching a garden hose to valve.
7. If hot and cold supply inlets are reversed simply remove cartridge and reinstall with cartridge flipped 180°. The handle adaptor (12) will need to be readjusted. To adjust handle adaptor remove and turn 180°. Handle should always turn through cold, then hot. Reinstall cartridge and tighten escutcheon to 150 in lbs. The system will need to be flushed again before installing shower heads.

8. To adjust temperature limit stop (11), turn valve to desired hottest temperature, remove temperature limit stop (11) turn clockwise and reinstall so that the white protrusion on cartridge is touching the red protrusion on the temperature limit stop.

9. After all flushing is done install shower heads and check system for leaks.

10. Assemble external trim to valve.

- Hand tighten escutcheon nut (20) on valve.
- Remove tape from gasket (15) and adhere gasket (centered on the top half of the back of cover plate (16)) so that 1/4 of the width of the gasket is sticking out beyond the back of the cover plate, see Figure 2.
- Place cover plate over escutcheon (19) and fasten with screws (18).
- Install handle onto cartridge with handle pointed down. Tighten set screw.

The ZURN TEMP-GARD III Pressure Balancing Shower Valve is equipped with an adjustable temperature limit stop. The temperature limit stop device is to be used to limit the valve handle from being turned to undesired hot water discharge temperatures. To adjust the temperature limit stop, see step 8 of the installation and reference figure 3.

IMPORTANT: Failure to adjust the temperature limit stop properly increases the chances for serious injury.

WARNING: This shower system may not protect the user from scalding when there is a failure of other temperature controlling devices elsewhere in the plumbing system.

Notes:

When there is a shutoff valve installed after the control valve, there shall be stop and check valves on the inlets. This is to eliminate hot and cold cross-connection in the event the valve handle is left on. Specify suffix “-SC” for ASSE approved checks.

If valve is going to be installed in “Thin Wall Application” such as a fiberglass or panel wall, it is recommended that an optional wall flange (RK7300-WF) be used. This wall flange is used to sandwich the wall between the valve body and cover plate.

OPERATION:

Cover Gasket:

Position gasket in back side of cover with the adhesive against the cover and the open end at bottom as shown.

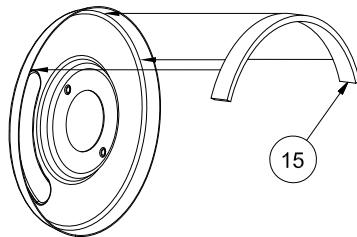

FIGURE 2

Adjusting Temperature Limit Stop:

Lift and turn temperature limit stop clockwise to reduce maximum temperature.

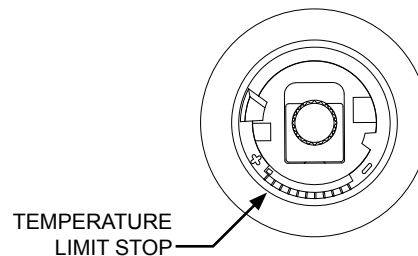
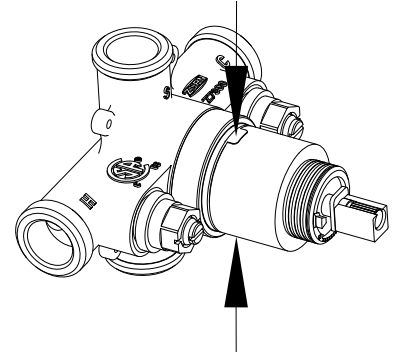

FIGURE 3

The main handle of the Temp-Gard III valve is for temperature control only. To turn valve on, the handle is turned counterclockwise through the cold position, to the warm and then to the hot position. The range of motion on the handle is 140°.

MAINTENANCE and SERVICE:

1. Remove handle (21) and cover plate (16).
2. Using a flathead screwdriver, turn both service stops (7) clockwise until they bottom out. This allows the valve to be serviced without turning off the main water supply. If service stops need to be repaired or replaced, the main water supply must be turned off and the service stop retainer (9) must be removed by turning counterclockwise.
3. Remove escutcheon nut (20) and escutcheon (19).
4. Remove cartridge (10) by placing thumb and forefinger where shown in figure 4 and carefully wiggling cartridge. **Caution: If cartridge is not removed in manner described damage may occur to cartridge.**
5. To determine if the piston in cartridge is functioning properly, shake cartridge side to side. The piston should make a clicking sound.
6. If no sound is heard when shaking, place cartridge in vinegar for at least 8 hours to remove scale and debris. If still no sound is heard replace cartridge with [RK7300-CART-3P](#) cartridge replacement kit.



HOLD HERE TO
REMOVE CARTRIDGE
FIGURE 4

TROUBLE SHOOTING:

PROBLEM	CAUSE	SOLUTION
Valve will not flow water.	Hot and cold water not turned on. Service Stops not open.	Be sure both supplies are turned on and service stops are open. Valve will not operate unless both HOT and COLD water inlets have pressure.
Water volume from valve is inconsistent during operation.	Pressure balancing piston housed in cartridge (10) assembly is blocked from free movement by foreign matter.	Remove and service cartridge as described in steps 1 through 6 of the MAINTENANCE and SERVICE section.
Valve delivers an insufficient quantity of Hot or Cold water.		
Temperatures fluctuate without moving temperature handle.		
Valve does not deliver desired hot water temperature.	Valve designed to deliver mixed hot and cold water in all handle positions.	Increase system hot water temperature.
Temperature out of valve reduces gradually during use.	Supply system is running out of hot water.	Reduce maximum flow rate out of valve or shower head. This will allow longer period of use before reduction of hot water supply.
Valve makes loud noise.	Piston in cartridge is moving back and forth because of a large pressure differential between the HOT and COLD water lines.	Alter the water system such that the pressure differential at all shower valves is no more than 5 psi.

Proper performance is dependent upon licensed, qualified personnel performing regular, periodic testing according to ZURN specifications and prevailing governmental & industry standards and codes and upon following these installation instructions. Failure to do so releases ZURN of any liability that it might otherwise have with respect to that device. Such failure could also result in an improperly functioning device.

PARTS BREAKDOWN

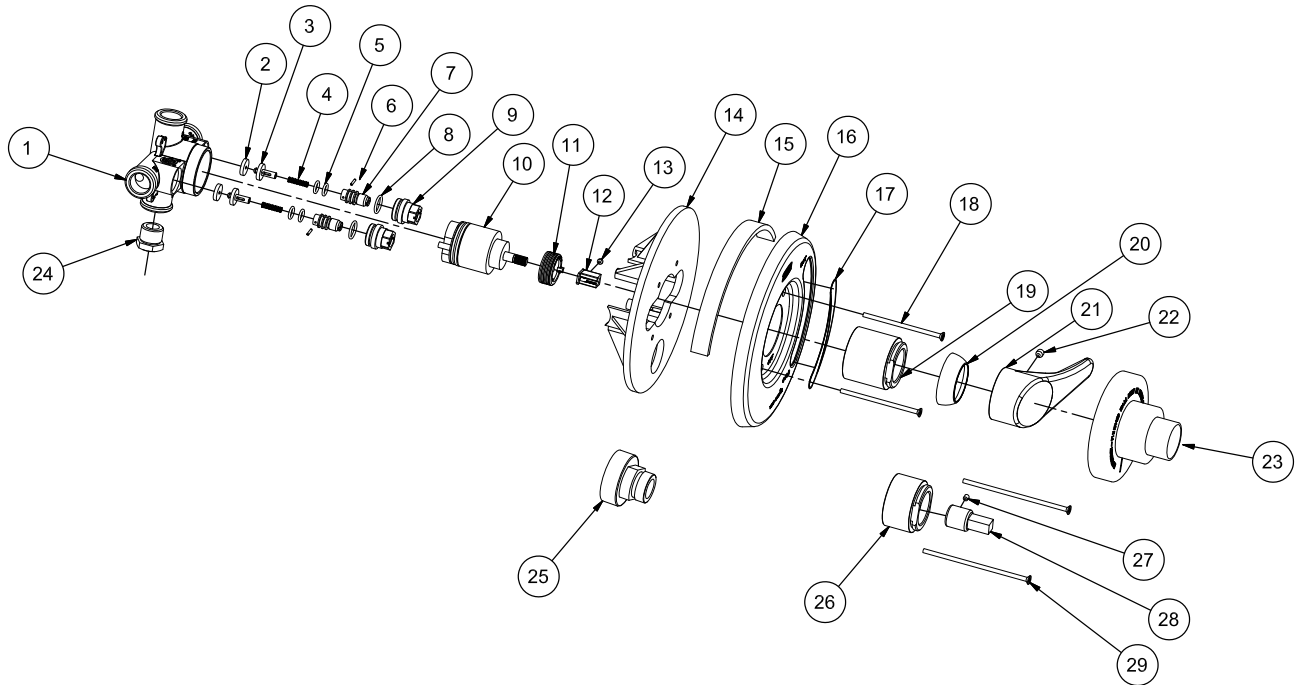

REPLACEMENT KITS:

RK7300-CART-3P CARTRIDGE KIT

- ITEM NO.
10. Pressure Balancing Cartridge
11. Temperature Limit Stop
12. Handle Adaptor
13. Set Screw

RK7300-50A SERVICE/CHECK STOP KIT (2) PER.

- ITEM NO.
2. Service Stop Washer
3. Service Stop Plunger
4. Spring
5. Stem O-Ring
6. Service Stop Roll Pin
7. Service Stop Stem
8. Retainer O-Ring
9. Service Stop Retainer

RK7300-WF WALL FLANGE KIT (OPTIONAL)

- ITEM NO.
14. Wall Flange

RK7300-LH LEVER HANDLE KIT

- ITEM NO.
21. Handle
22. Set Screw
**RK7300-11AE-001
COVER SCREWS KIT
(2) PER**
ITEM NO.
18. Cover Plate Screw, 3"

- RK7300-EXT
EXTENSION KIT (OPTIONAL)**
ITEM NO.
26. Escutcheon Extension
27. Set Screw
28. Stem Extension
29. Cover Plate Screws, 4"

- RK7300-20HB
FLUSHING OUT KIT (OPTIONAL)**
ITEM NO.
25. Hose Bib

- RK7300-8MT-002
COVER PLATE KIT**
ITEM NO.
16. Cover Plate w/ Etched Lettering
17. Temperature Indicator

PARTS:

1. Valve Body
2. Service Stop Washer
3. Service Stop Plunger
4. Spring
5. Stem O-Ring
6. Service Stop Roll Pin
7. Service Stop Stem
8. Retainer O-Ring
9. Service Stop Retainer
10. Pressure Balancing Cartridge
11. Temperature Limit Stop
12. Handle Adaptor
13. Set Screw
14. Wall Flange
15. Gasket (7000-90).
16. Cover Plate w/ Etched Lettering
17. Temperature Indicator
18. Cover Plate Screw, 3"
19. Escutcheon (7300-81MT)
20. Escutcheon Nut (7300-9MT)
21. Handle
22. Set Screw
23. Mud Guard (7300-17)
24. Tub Plug (7300-7B)
25. Hose Bib
26. Escutcheon Extension
27. Set Screw
28. Stem Extension
29. Cover Plate Screw, 4"